

FCC & IC TEST REPORT for DTS Device (2.4GHz) No. 161201799SHA-001

Applicant : Pass & Seymour, Inc., d/b/a Legrand
301 Fulling Mill Road, Suite G, Middletown,
Pennsylvania 17057 USA

Manufacturer : Hzsamko Technologies Co.,Ltd.
No.8,Jiaqi Road,Xianlin Street,Yuhang District,Hangzhou,
China.

Equipment : Player Subsystem

Type/Model : PCBA-200010-01 Player System

SUMMARY

The equipment complies with the requirements according to the following standard(s):

47CFR Part 15 (2015): Radio Frequency Devices

ANSI C63.10 (2013): American National Standard of Procedures for Compliance Testing of Unlicensed Wireless Devices

RSS-247 (Issue 1, 2015): Digital Transmission Systems (DTSSs), Frequency Hopping Systems (FHSs) and Licence-Exempt Local Area Network (LE-LAN) Devices

RSS-Gen Issue 4 (November 2014): General Requirements and Information for the Certification of Radiocommunication Equipment

Date of issue: Jan 9, 2017

Prepared by:

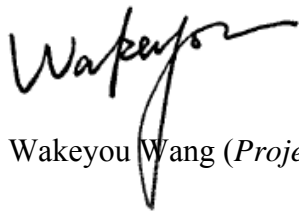

Wakeyou Wang (*Project Engineer*)

Reviewed by:

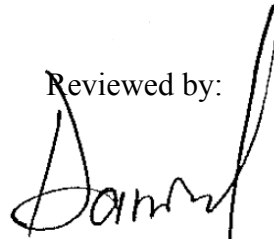

Daniel Zhao (*Reviewer*)



Description of Test Facility

Name: Intertek Testing Services Limited Shanghai
Address: Building 86, No. 1198 Qinzhou Rd., North, Shanghai 200233, P.R. China

FCC Registration Number: 236597
IC Assigned Code: 2042B-1

Name of contact: Jonny Jing
Tel: +86 21 61278271
Fax: +86 21 54262353

Content

SUMMARY	1
DESCRIPTION OF TEST FACILITY	2
1. GENERAL INFORMATION	5
1.1 Applicant Information.....	5
1.2 Identification of the EUT	5
1.3 Technical specification	6
1.4 Mode of operation during the test / Test peripherals used.....	7
2. TEST SPECIFICATION	8
2.1 Instrument list	8
2.2 Test Standard	8
2.3 Test Summary	9
3. MINIMUM 6dB BANDWIDTH	10
3.1 Limit.....	10
3.2 Test Configuration	10
3.3 Test Procedure and test setup.....	10
3.4 Test Protocol	11
3.5 Measurement uncertainty.....	18
4. MAXIMUM PEAK OUTPUT POWER	19
4.1 Test limit	19
4.2 Test Configuration	19
4.3 Test procedure and test setup.....	19
4.4 Test protocol	20
4.5 Measurement uncertainty.....	20
5. POWER SPECTRUM DENSITY	21
5.1 Test limit	21
5.2 Test Configuration	21
5.3 Test procedure and test setup.....	21
5.4 Test Protocol	22
5.5 Measurement uncertainty.....	29
6. RADIATED EMISSION IN THE RESTRICTED BANDS	30
6.1 Test limit	30
6.2 Test Configuration	30
6.3 Test procedure and test setup.....	31
6.4 Test protocol	32
6.5 Measurement uncertainty.....	35
7. EMISSION OUTSIDE THE FREQUENCY BAND	36
7.1 Limit.....	36
7.2 Test Configuration	36
7.3 Test procedure and test setup.....	36
7.4 Test protocol	37
7.5 Measurement uncertainty.....	59
8. POWER LINE CONDUCTED EMISSION	60
8.1 Limit.....	60
8.2 Test configuration	60
8.3 Test procedure and test set up.....	61
8.4 Test protocol	62



8.5 Measurement uncertainty 63
9. ANTENNA REQUIREMENT 64

1. General Information

1.1 Applicant Information

Applicant: Pass & Seymour, Inc., d/b/a Legrand
301 Fulling Mill Road, Suite G, Middletown,
Pennsylvania 17057 USA

Name of contact: Fred G. Duffy

Tel: (717)5465413

Fax: (717)7022546

Manufacturer: Hzsamko Technologies Co.,Ltd.
No.8,Jiaqi Road,Xianlin Street,Yuhang
District,Hangzhou, China.

Sample received date : Dec 20, 2016

Sample Identification No : /

Date of test : Dec 20, 2016 ~ Dec 30, 2016

1.2 Identification of the EUT

Equipment: Player Subsystem

Type/model: PCBA-200010-01 Player System

FCC ID: YV8-20001001

IC: 9922A-20001001

1.3 Technical specification

Operation Frequency Band: 2412 - 2462 MHz
 Modulation: DBPSK @1Mbps
 DQPSK@2Mbp
 CCK@5.5/11Mbps
 BPSK@6/9 Mbps
 QPSK@12/18Mbps
 16-QAM@24Mbps
 64-QAM@48/54Mpb and above

Gain of Antenna:

Antenna Type	Gain of antenna
Embedded WIFI Dual Band Antenna	2.4GHz band: 2.79dBi
	5GHz band: 4.20dBi

Rating: DC 5V

Description of EUT: The EUT is a wireless audio device containing Wi-Fi module.

Port identification: Audio in × 1; Audio out × 1; USB × 1; LAN × 1

Category of EUT: Class B

EUT type: Table top Floor standing

EUT Modes: 802.11a/b/g/n20 (802.11b/g/n20 assessed in this report)

Channel Number: Channel 1 - 11 for 2412MHz~2462MHz

Channel Description: The channel spacing is 5MHz.

MIMO Function Description:

Freq. Band	Modulation	Transmission / Idle		Beam forming	Beam forming gain
		Chain 1	Chain 2		
2412 – 2462 MHz	802.11b	Transmission	Idle	NO	0 dBi
	802.11g	Transmission	Idle	NO	0 dBi
	802.11 n20	Transmission	Transmission	NO	0 dBi

1.4 Mode of operation during the test / Test peripherals used

While testing transmitting mode of EUT, the internal modulation was applied.

The lowest, middle and highest channel were tested as representatives (2412MHz, 2437MHz and 2462MHz).

Item No.	Name	Band and Model	Description
1	Laptop computer	HP ProBook 6470b	NA
2	AC/DC adapter	Lenovo C-P64	AC 100-240V input; DC 5V, 1.5A output

Product SW/HW version	Radio SW/HW version	Test SW Version
N/A	N/A	N/A

Test software setting:

The power level setting for 802.11b/g/n is used with the software offered by the manufactory.

Mode 1	Frequency (MHz)	Software Setting	Note
802.11b	2412	17.0	/
	2437	17.0	/
	2462	17.0	/
802.11g	2412	17.0	/
	2437	17.0	/
	2462	11.0	/
802.11n20	2412	17.0	/
	2437	17.0	/
	2462	11.0	/

Data rate VS Power

The pre-scan for the conducted power with all rates in each modulation and bands was used, and the worst case was found and used in all test cases.

After this pre-scan, we choose the following table of the data rata as the worst case.

Mode	Worst case data rate
802.11b	1Mbps
802.11g	6Mbps
802.11 n20	MCS8

2. Test Specification

2.1 Instrument list

Equipment	Type	Manu.	Internal no.	Cal. Date	Due date
Test Receiver	ESCS 30	R&S	EC 2107	2016-10-21	2017-10-20
Test Receiver	ESIB 26	R&S	EC 3045	2016-10-20	2017-10-19
A.M.N.	ESH2-Z5	R&S	EC 3119	2016-1-9	2017-1-8
Bilog Antenna	CBL 6112D	TESEQ	EC 4206	2016-4-28	2017-4-27
Horn antenna	HF 906	R&S	EC 3049	2016-4-28	2017-4-27
Pre-amplifier	Pre-amp 18	R&S	EC 3222	2016-4-12	2017-4-11
Semi-anechoic chamber	-	Albatross project	EC 3048	2016-5-12	2017-5-11
High Pass Filter	WHKX 1.0/15G-10SS	Wainwright	EC4297-1	2016-1-8	2017-1-7
Power sensor / Power meter	N1911A/N1921A	Agilent	EC4318	2016-04-12	2017-04-11
Temperature Camber	SETH-E	tayasaf	EC4315	2016-4-9	2017-4-8
Spectrum analyzer	E7402A	Agilent	EC2254	2016-08-16	2017-08-15

2.2 Test Standard

47CFR Part 15:2015
ANSI C63.10 (2013)
RSS-247 (Issue 1, 2015)
RSS-Gen Issue 4 (November 2014)
KDB 558074 D01 DTS Meas Guidance v03r05

2.3 Test Summary

This report applies to tested sample only. This report shall not be reproduced in part without written approval of Intertek Testing Service Shanghai Limited.

TEST ITEM	FCC REFERANCE	IC REFERANCE	RESULT
Minimum 6dB Bandwidth	15.247(a)(2)	RSS-247 Issue 1 Clause 5	Pass
Maximum peak output power	15.247(b)	RSS-247 Issue 1 Clause 5	Pass
Power spectrum density	15.247(e)	RSS-247 Issue 1 Clause 5	Pass
Radiated emission	15.205 & 15.209	RSS-247 Issue 1 Clause 5	Pass
Emission outside the frequency band	15.247(d)	RSS-247 Issue 1 Clause 5	Pass
Power line conducted emission	15.207	RSS-Gen Issue 4 Clause 8.8	Pass

3. Minimum 6dB Bandwidth

Test result: PASS

3.1 Limit

For systems using digital modulation techniques that may operate in the 902 - 928 MHz, 2400 - 2483.5 MHz and 5725 - 5850 MHz bands, the minimum 6 dB bandwidth shall be at least 500 kHz.

3.2 Test Configuration

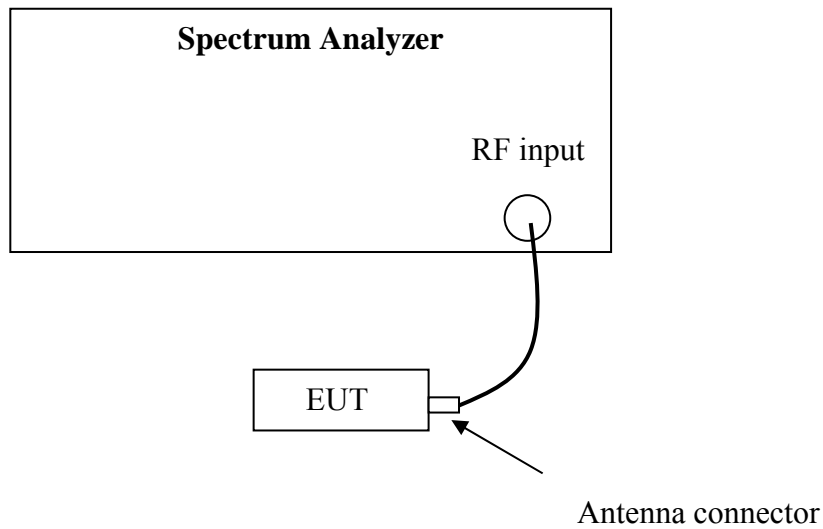

3.3 Test Procedure and test setup

The minimum 6dB bandwidth per FCC §15.247(a)(2) is measured using the Spectrum Analyzer according to DTS test procedure of “KDB558074 D01 DTS Meas Guidance v03r05” for compliance to FCC 47CFR 15.247 requirements(clause 8.2).

3.4 Test Protocol

Temperature : 25°C
Relative Humidity : 55%

Mode	CH	Chain 1 (MHz)	Chain 2 (MHz)	Limit (MHz)
802.11b	L	11.12	-	≥0.5
	M	11.12	-	
	H	11.20	-	

Frequency L – Chain 1

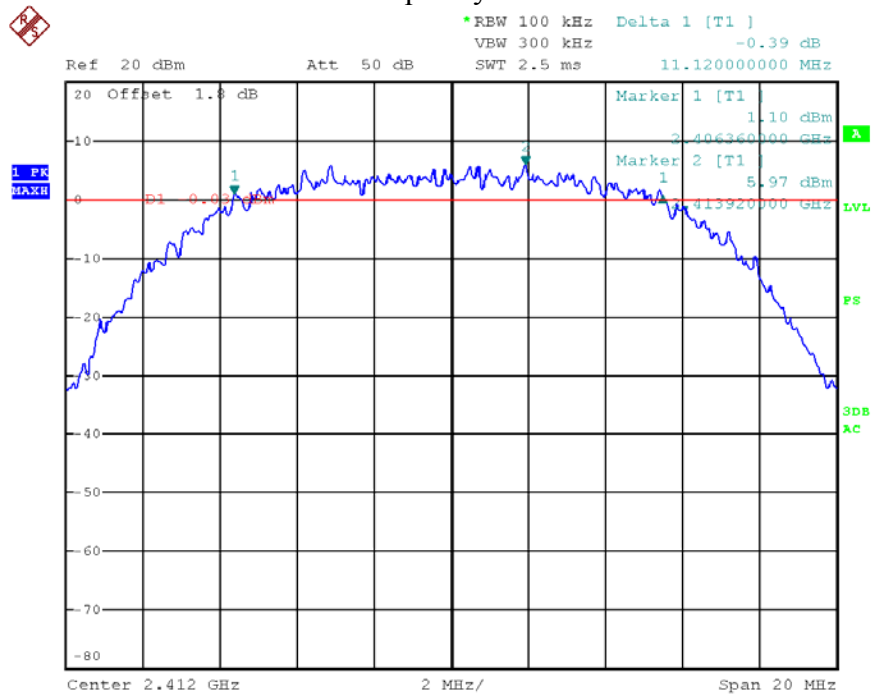

Frequency M – Chain 1

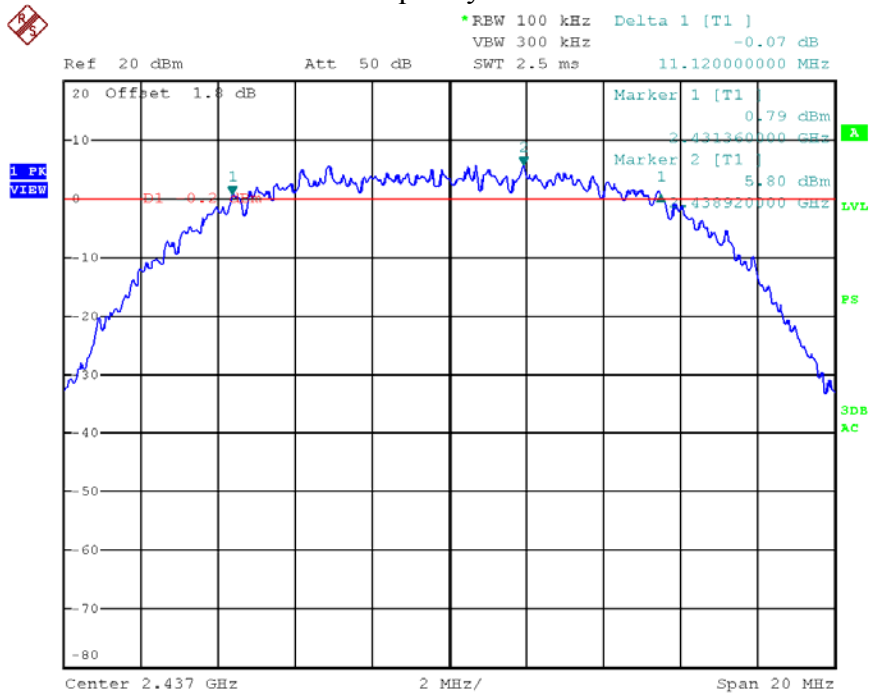

Frequency H – Chain 1

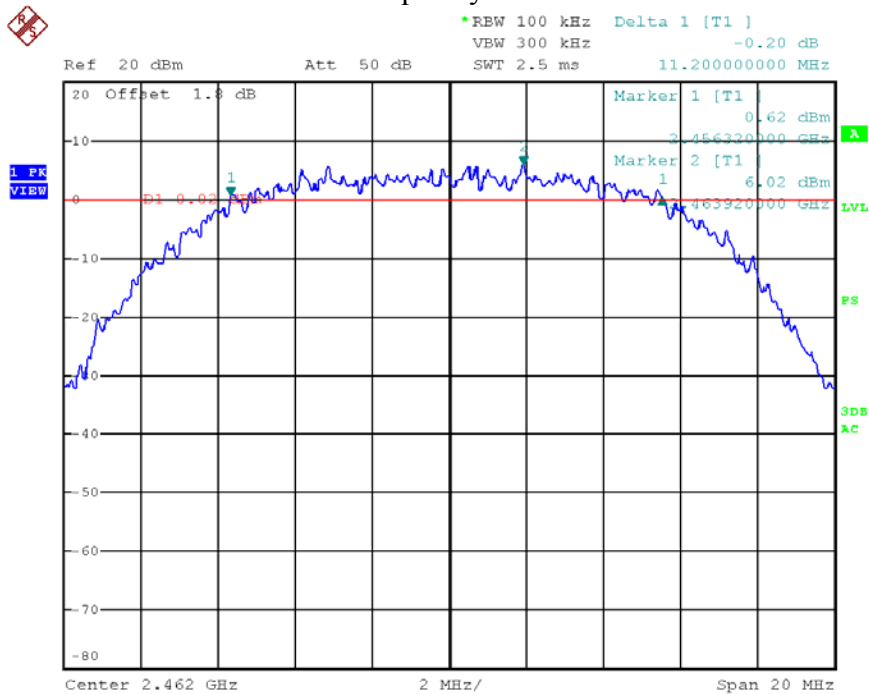

Mode	CH	Chain 1 (MHz)	Chain 2 (MHz)	Limit (MHz)
802.11g	L	16.48	-	≥0.5
	M	16.44	-	
	H	16.48	-	

Frequency L – Chain 1

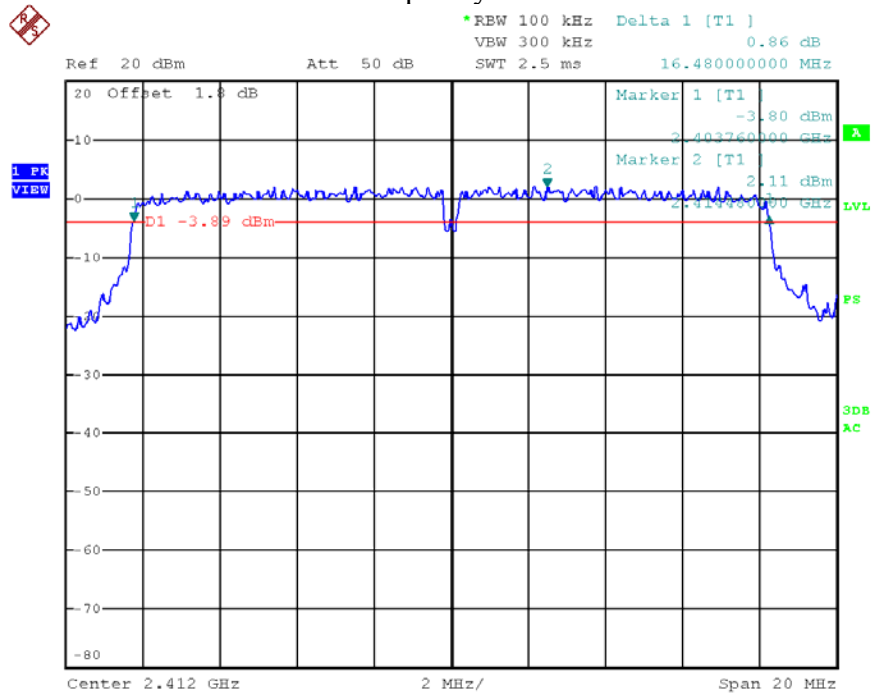

Frequency M – Chain 1

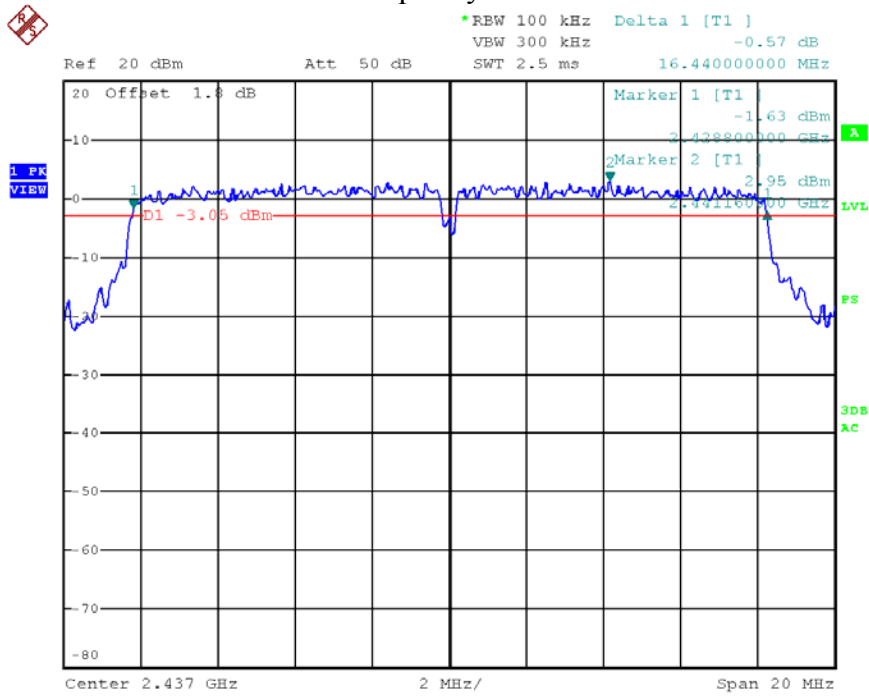

Frequency H – Chain 1

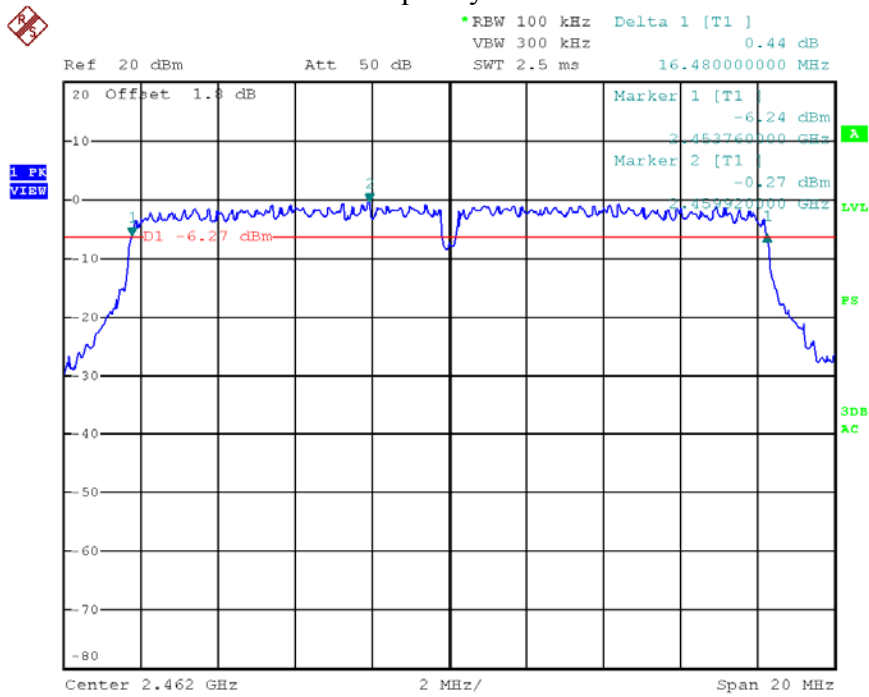

Mode	CH	Chain 1 (MHz)	Chain 2 (MHz)	Limit (MHz)
802.11 n20	L	17.60	17.44	≥0.5
	M	17.60	17.52	
	H	17.60	17.60	

Frequency L – Chain 1

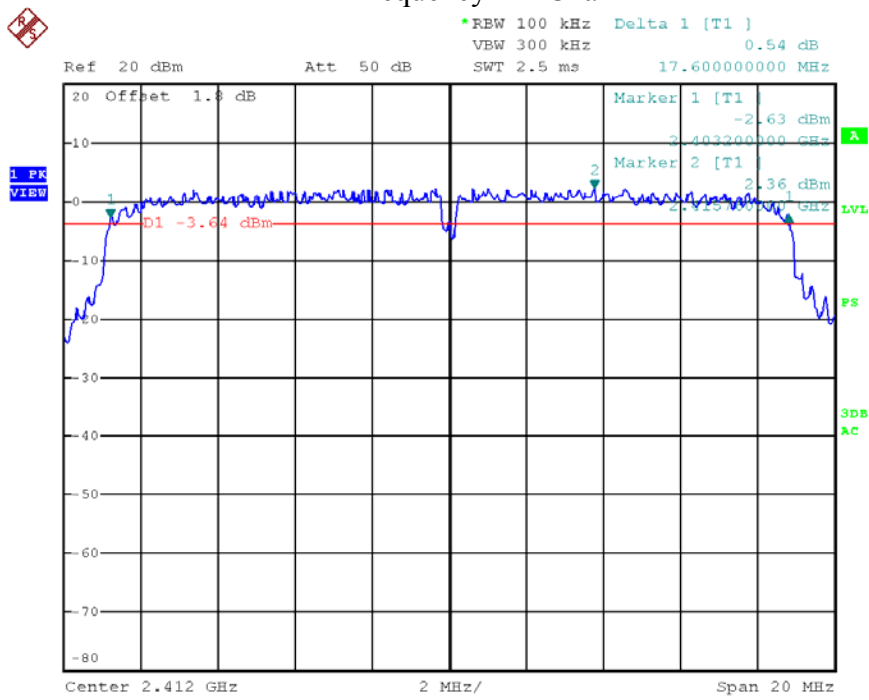

Frequency M – Chain 1

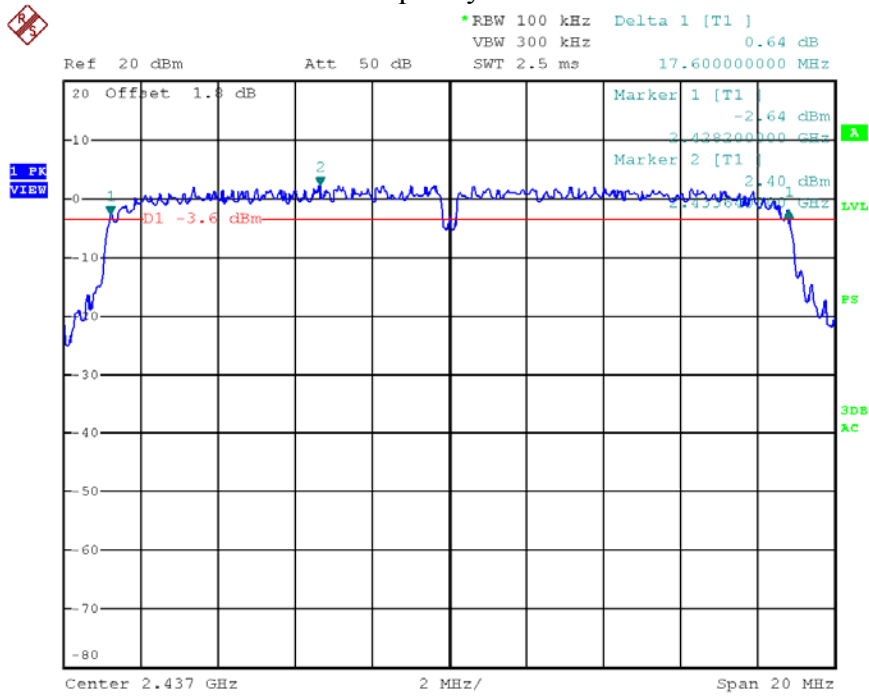

Frequency H – Chain 1

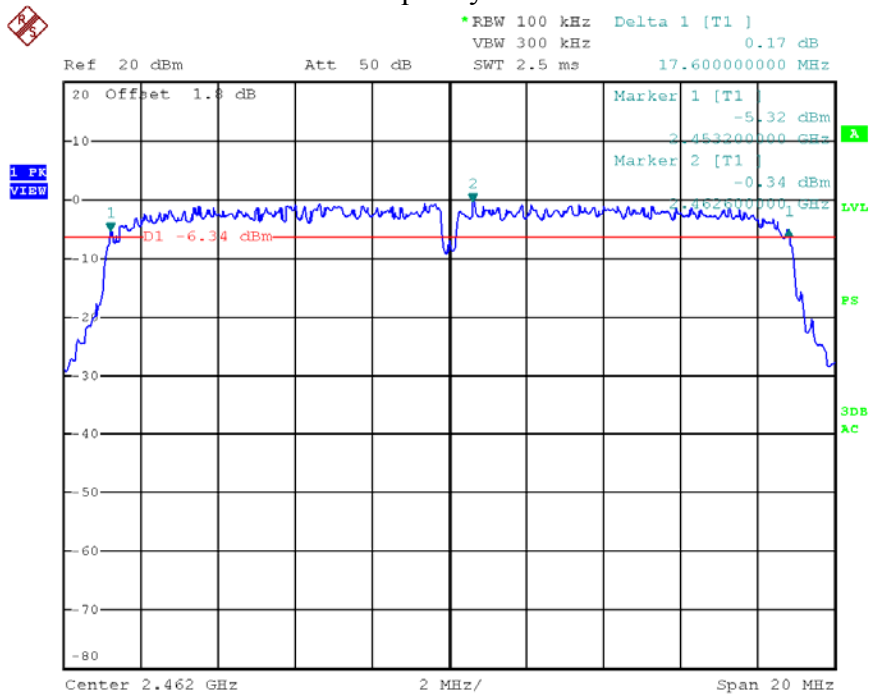

Frequency L – Chain 2

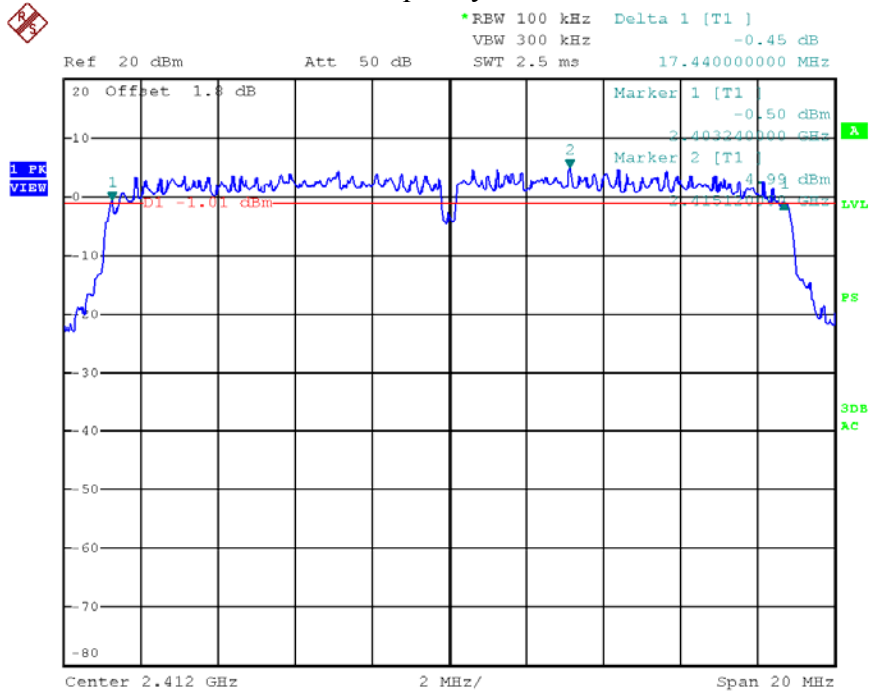

Frequency M – Chain 2

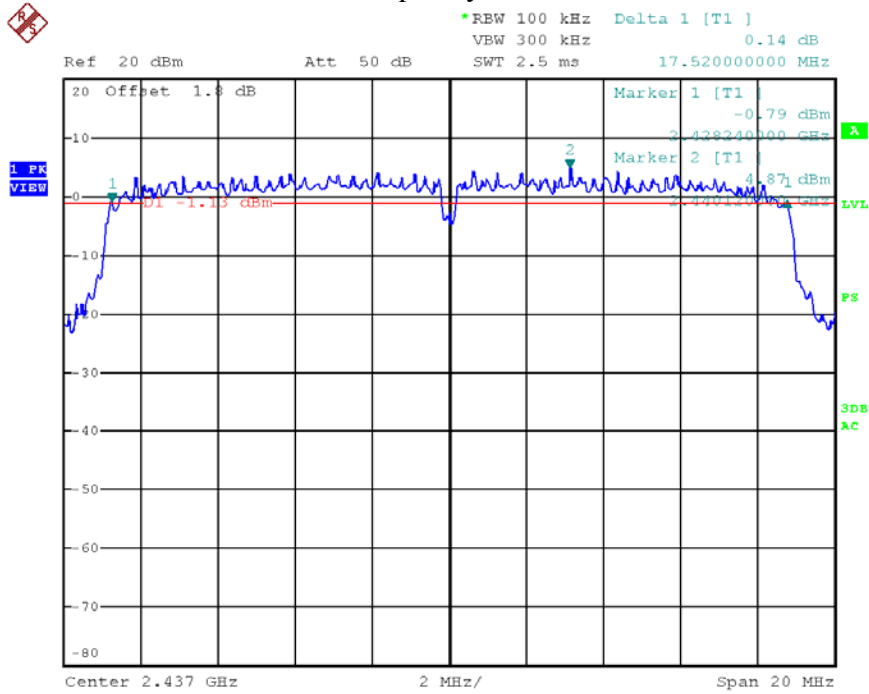

Frequency H – Chain 2

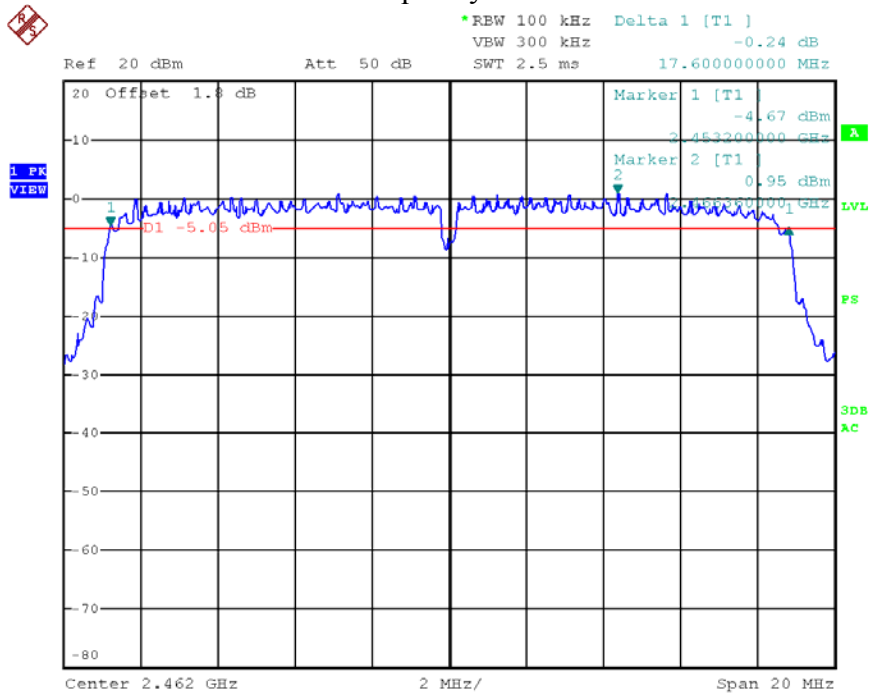

3.5 Measurement uncertainty

Measurement uncertainty: $\pm 3 \%$

The measurement uncertainty is given with a confidence of 95%, $k=2$.

4. Maximum peak output power

Test result: Pass

4.1 Test limit

- For frequency hopping systems operating in the 2400-2483.5 MHz band employing at least 75 non-overlapping hopping channels, and all frequency hopping systems in the 5725-5850 MHz band: 1 watt
- For all other frequency hopping systems in the 2400-2483.5 MHz band: 0.125 watts
- For systems using digital modulation in the 902-928 MHz, 2400-2483.5 MHz, and 5725-5850 MHz bands: 1 Watt.

If the transmitting antenna of directional gain greater than 6dBi is used, the power shall be reduced by the amount in dB that the directional gain of the antenna exceeds 6dBi.

4.2 Test Configuration

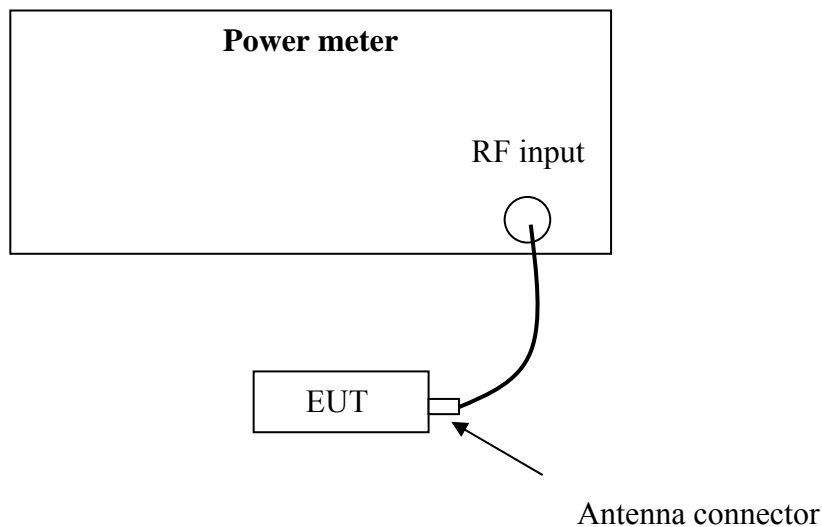

4.3 Test procedure and test setup

The EUT was tested according to DTS test procedure of “KDB558074 D01 DTS Meas Guidance v03r05” for compliance to FCC 47CFR 15.247 requirements (clause 9.1.2).

4.4 Test protocol

Temperature : 25 °C
Relative Humidity : 55 %

Mode	CH	Cable loss (dB)	Reading (dBm)		Total Peak power (dBm)	Limit (dBm)
			Chain 1	Chain 2		
802.11b	L	1.8	21.30	-	21.30	30.00
	M	1.8	21.40	-	21.40	30.00
	H	1.8	21.20	-	21.20	30.00
802.11g	L	1.8	25.70	-	25.70	30.00
	M	1.8	26.00	-	26.00	30.00
	H	1.8	24.50	-	24.50	30.00
802.11n20	L	1.8	25.70	26.40	29.10	30.00
	M	1.8	26.30	26.80	29.60	30.00
	H	1.8	23.80	23.90	26.90	30.00

4.5 Measurement uncertainty

Measurement uncertainty: $\pm 0.74\text{dB}$

The measurement uncertainty is given with a confidence of 95%, $k=2$.

5. Power spectrum density

Test result: Pass

5.1 Test limit

For digitally modulated systems, the power spectral density conducted from the intentional radiator to the antenna shall not be greater than 8dBm in any 3 kHz band during any time interval of continuous transmission.

5.2 Test Configuration

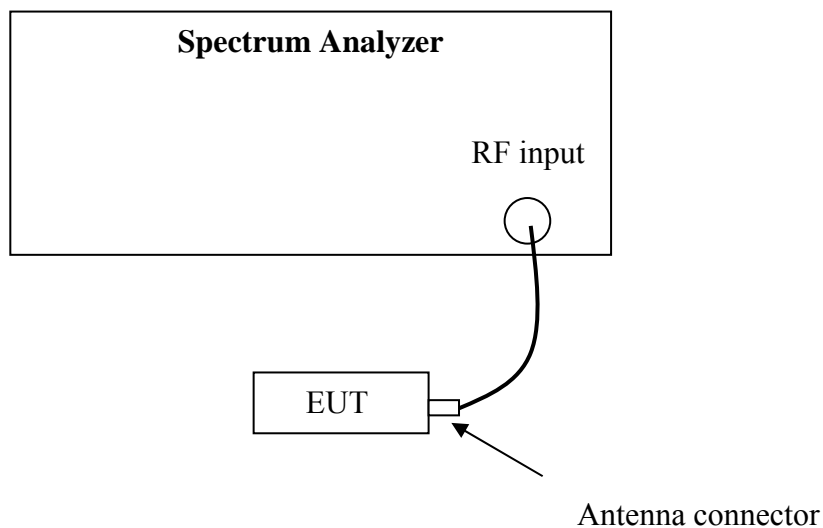

5.3 Test procedure and test setup

The power output per FCC §15.247(e) was tested according to DTS test procedure of “KDB558074 D01 DTS Meas Guidance v03r05” (clause 10.2) for compliance to FCC 47CFR 15.247 requirements.

5.4 Test Protocol

Temperature : 25 °C

Relative Humidity: 55 %

Mode	CH	Cable loss (dB)	PSD (dBm/100kHz)		Total PSD (dBm/100kHz)	Limit (dBm/3kHz)
			Chain 1	Chain 2		
802.11b	L	1.8	5.50	-	5.50	≤8.00
	M	1.8	5.48	-	5.48	
	H	1.8	5.77	-	5.77	

Frequency L – Chain 1

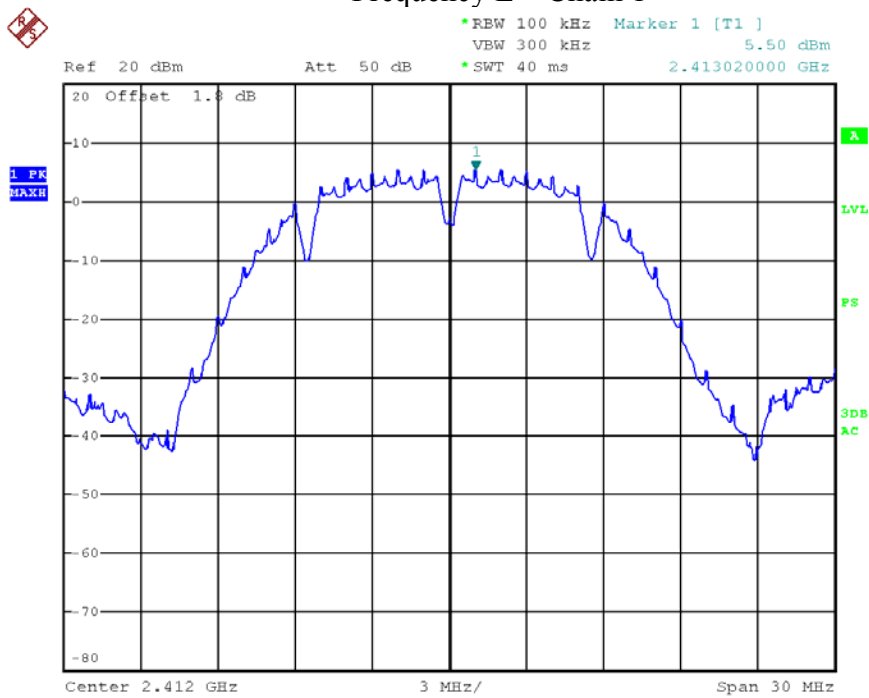

Frequency M – Chain 1

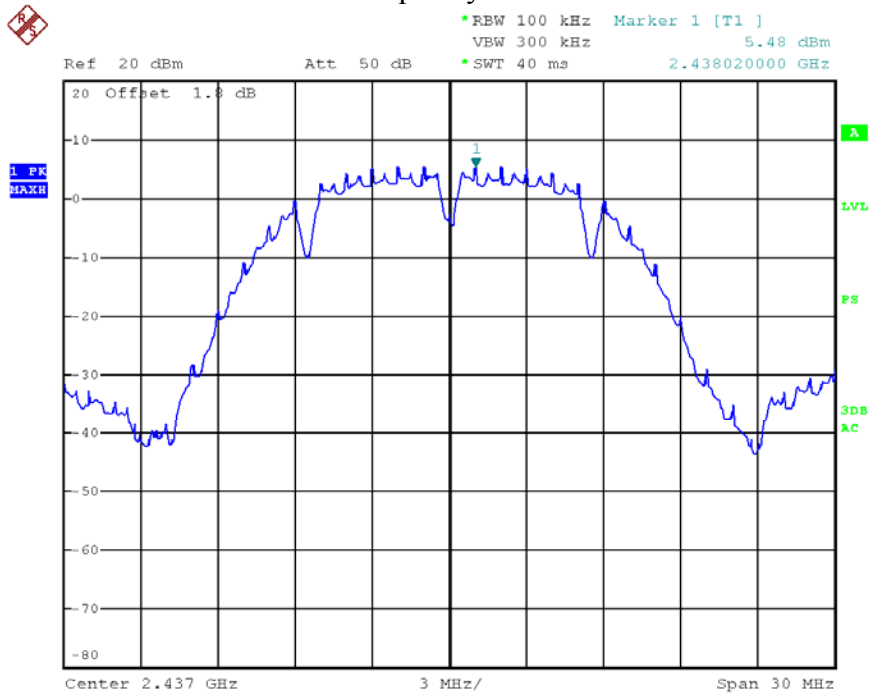

Frequency H – Chain 1

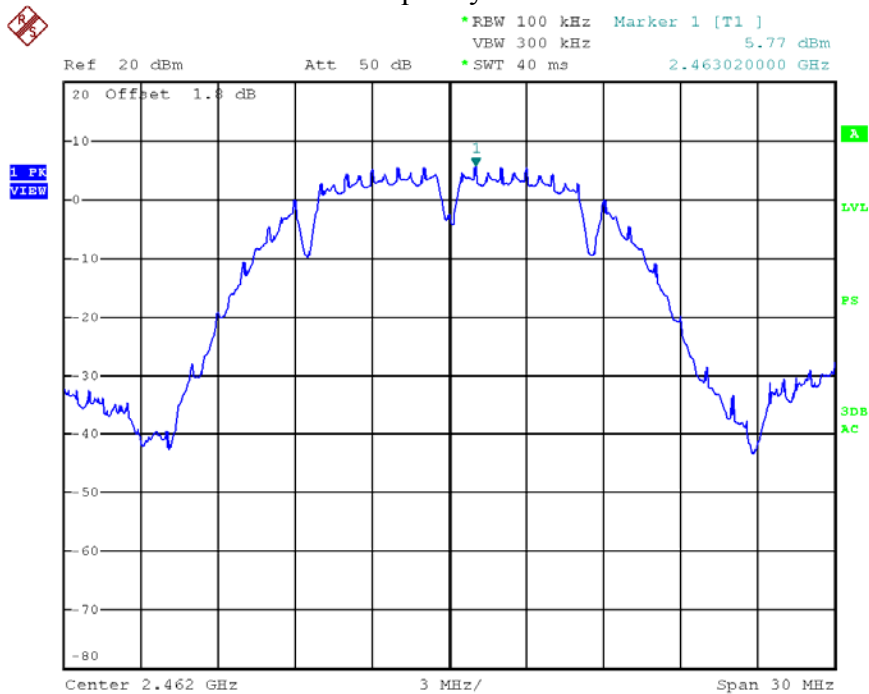

Mode	CH	Cable loss (dB)	PSD (dBm/100kHz)		Total PSD (dBm/100kHz)	Limit (dBm/3kHz)
			Chain 1	Chain 2		
802.11g	L	1.8	3.03	-	3.03	≤8.00
	M	1.8	3.21	-	3.21	
	H	1.8	-0.10	-	-0.10	

Frequency L – Chain 1

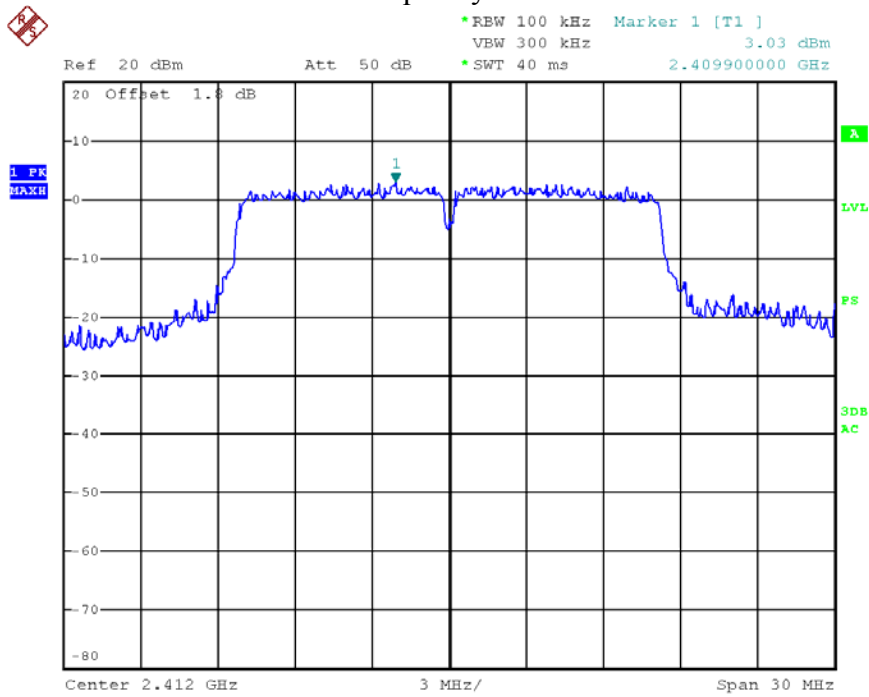

Frequency M – Chain 1

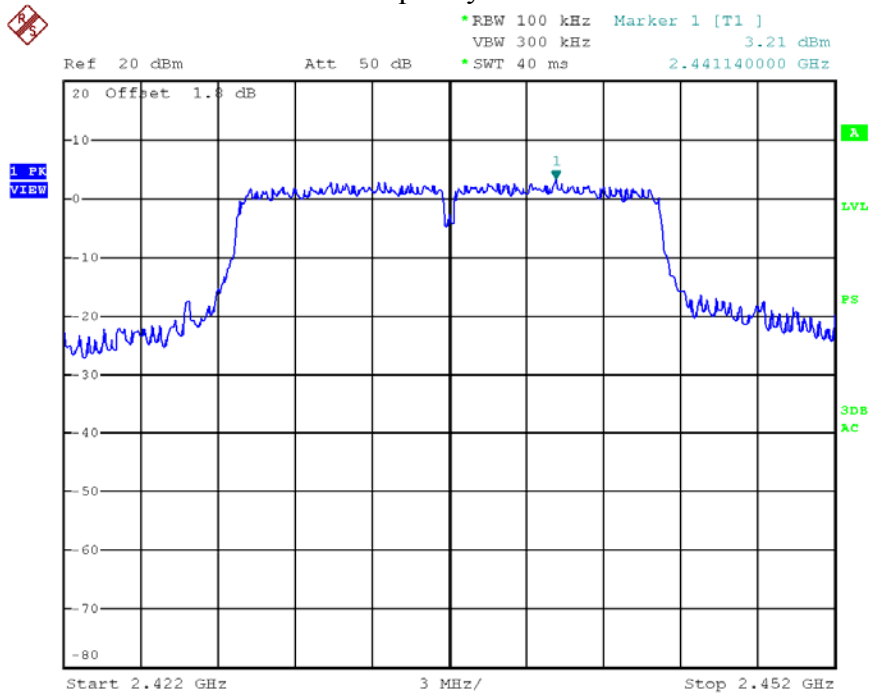

Frequency H – Chain 1

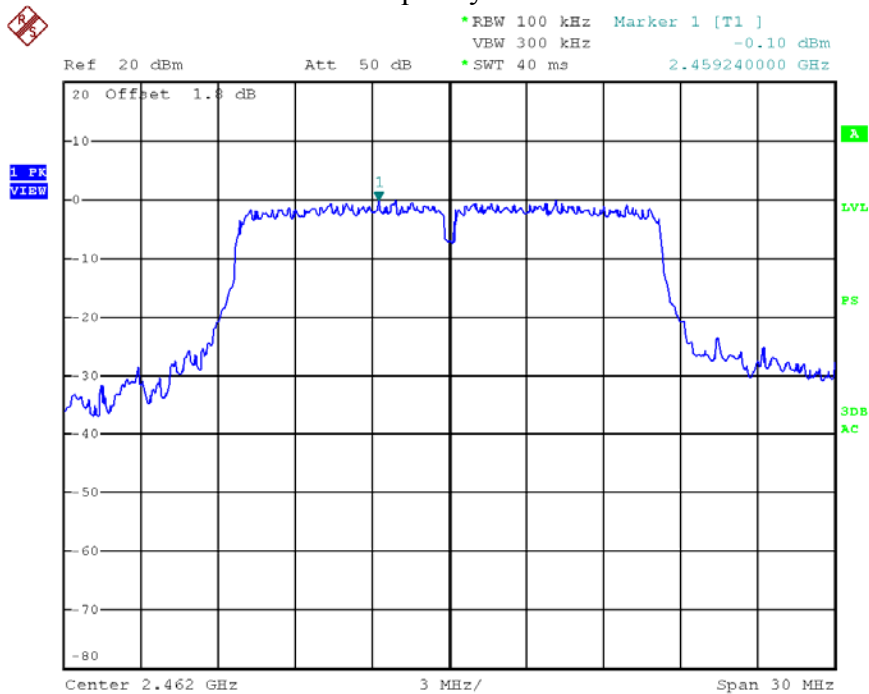

Mode	CH	Cable loss (dB)	PSD (dBm/100kHz)		Total PSD (dBm/100kHz)	Limit (dBm/3kHz)
			Chain 1	Chain 2		
802.11n20	L	1.8	2.40	3.42	5.95	≤8.00
	M	1.8	2.79	4.02	6.46	
	H	1.8	-0.32	0.35	3.04	

Frequency L – Chain 1

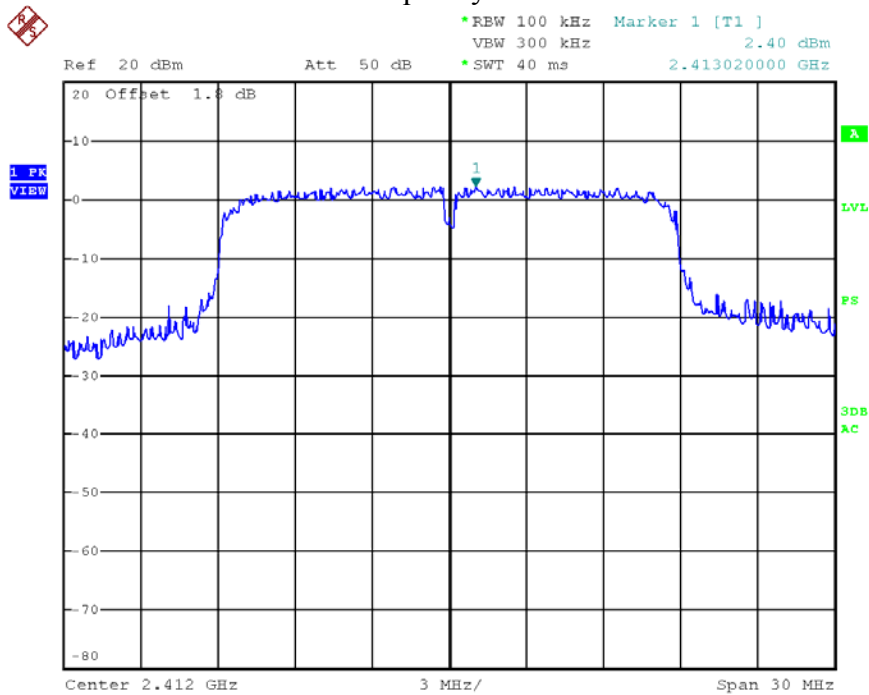

Frequency M – Chain 1

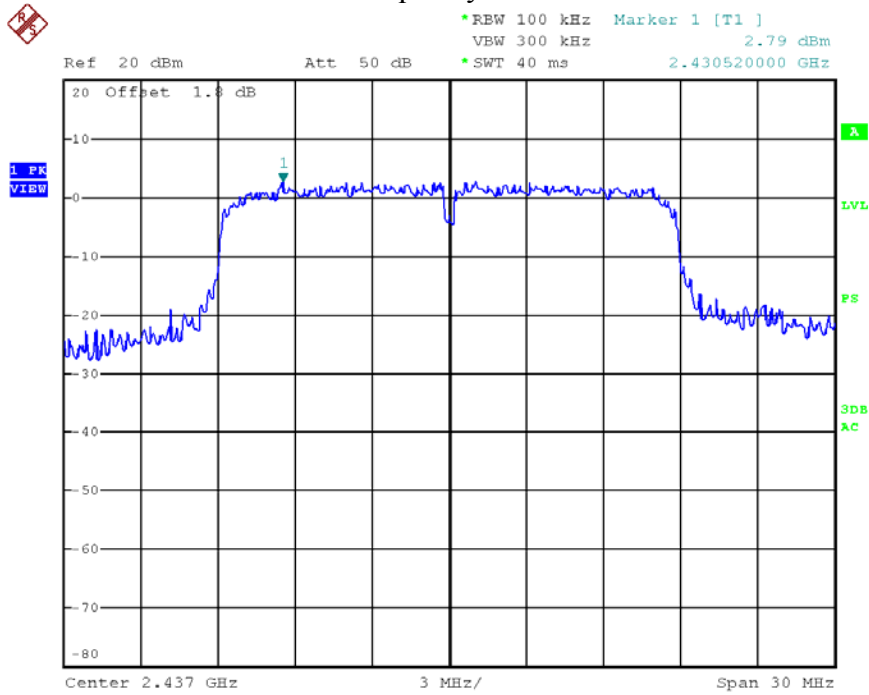

Frequency H – Chain 1

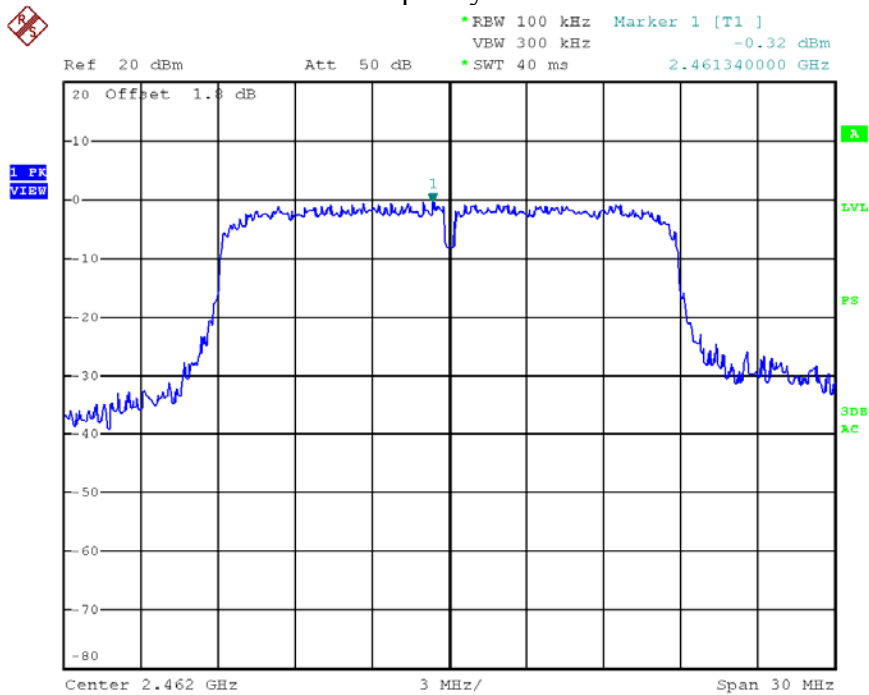

Frequency L – Chain 2

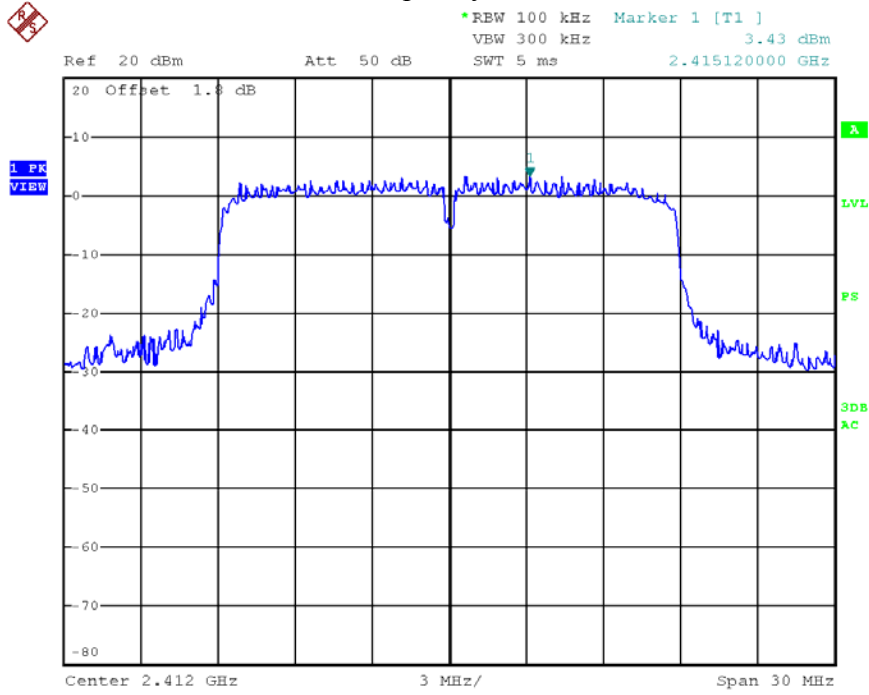

Frequency M – Chain 2

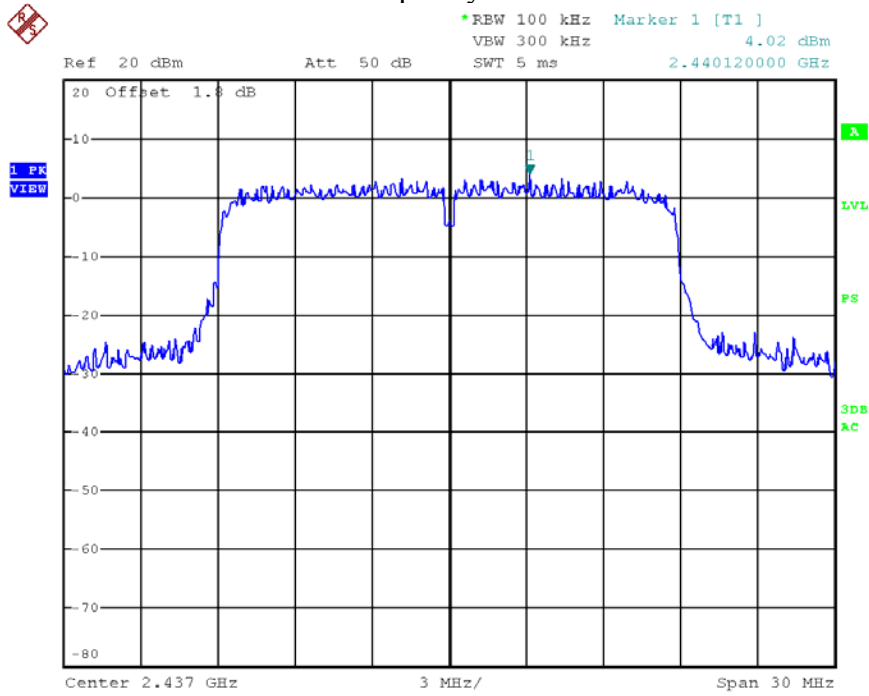

Frequency H – Chain 2

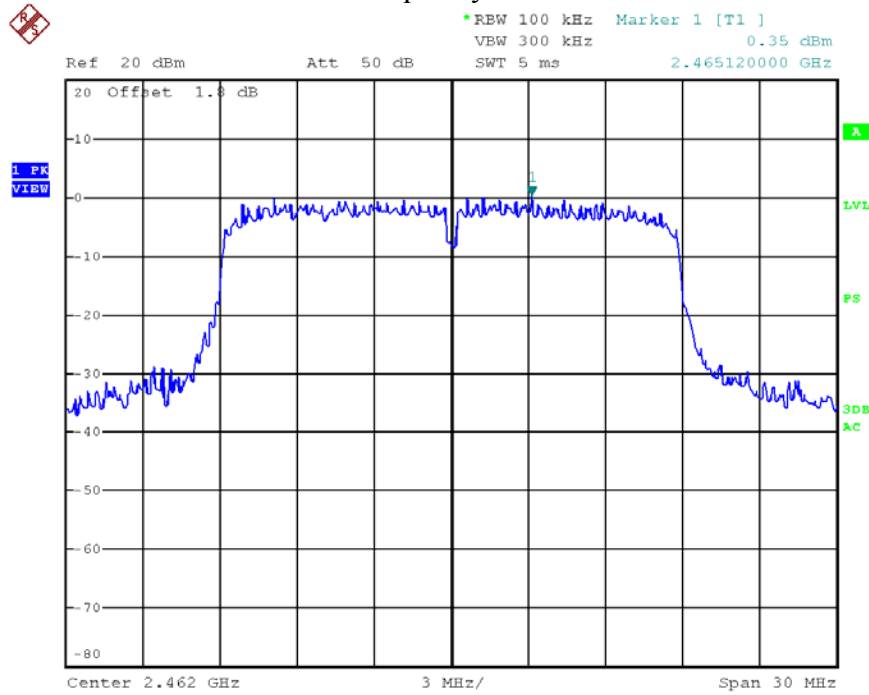

5.5 Measurement uncertainty

Measurement uncertainty: $\pm 0.74\text{dB}$

The measurement uncertainty is given with a confidence of 95%, $k=2$.

6. Radiated emission in the restricted bands

Test result: PASS

6.1 Test limit

The radiated emissions which fall in the restricted bands, as defined in §15.205(a), must also comply with the radiated emission limits specified in §15.209(a) showed as below:

Frequency (MHz)	Field Strength (dBuV/m)	Measurement Distance (m)
30 - 88	40.0	3
88 - 216	43.5	3
216 - 960	46.0	3
Above 960	54.0	3

6.2 Test Configuration

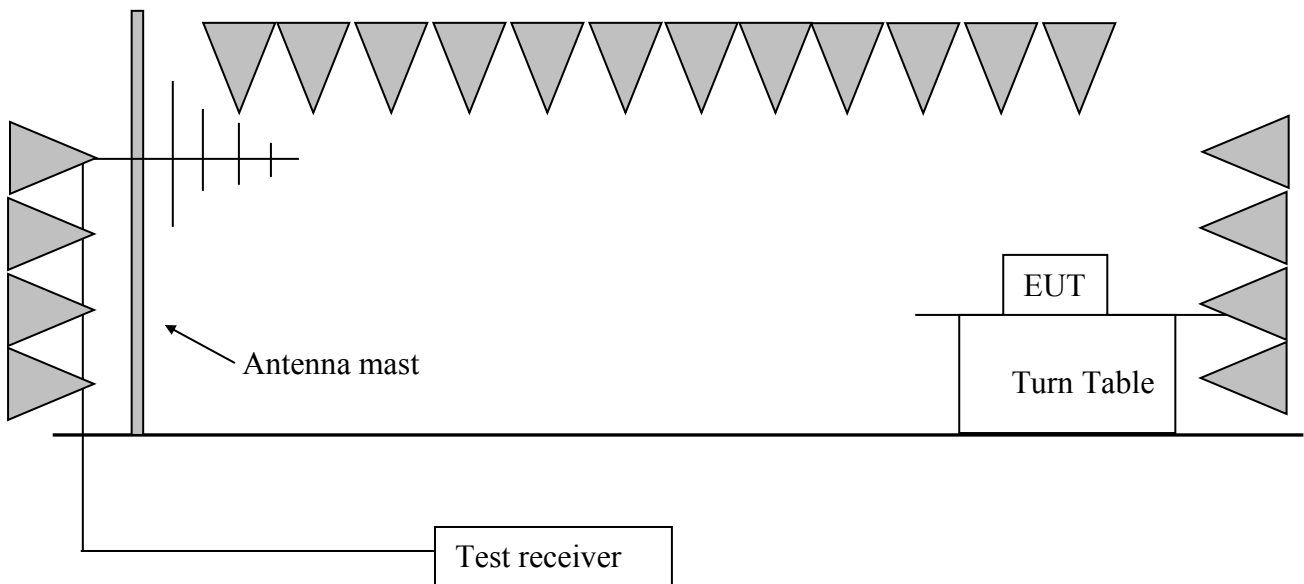

6.3 Test procedure and test setup

The measurement was applied in a semi-anechoic chamber. While testing for spurious emission higher than 1GHz, if applied, the pre-amplifier would be equipped just at the output terminal of the antenna.

The EUT and simulators were placed on a 0.8m high wooden turntable above the horizontal metal ground plane. The turn table rotated 360 degrees to determine the position of the maximum emission level. The EUT was set 3 meters away from the receiving antenna which was mounted on an antenna mast. The antenna moved up and down between from 1meter to 4 meters to find out the maximum emission level.

The EUT was tested according to DTS test procedure of KDB558074 D01 DTS “Meas Guidance v03r05” (clause 12) for compliance to FCC 47CFR 15.247 requirements.

6.4 Test protocol

Temperature : 25 °C
Relative Humidity : 55 %

Mode 802.11b

CH	Antenna	Frequency (MHz)	Correct Factor (dB/m)	Corrected Reading (dBuV/m)	Limit (dBuV/m)	Margin (dB)	Detector
L	H	2413.43	34.50	100.50	/	/	PK
	V	55.27	8.30	34.80	40.00	5.20	PK
	H	319.64	16.10	45.00	46.00	1.00	PK
	V	589.84	21.60	41.50	46.00	4.50	PK
	H	2390.00	34.40	62.00	74.00	12.00	PK
	H	2390.00	34.40	42.30	54.00	11.70	AV
	H	3210.42	-8.00	52.60	54.00	1.40	PK
	H	4823.64	-3.50	56.20	74.00	17.80	PK
	H	4823.53	-3.50	52.10	54.00	1.90	AV
M	H	2438.66	34.60	101.30	/	/	PK
	V	55.27	8.30	34.80	40.00	5.20	PK
	H	319.64	16.10	45.00	46.00	1.00	PK
	V	589.84	21.60	41.50	46.00	4.50	PK
	H	3244.93	-7.80	51.50	54.00	2.50	PK
	H	4881.90	-3.40	56.70	74.00	17.30	PK
	H	4881.90	-3.40	52.50	54.00	1.50	AV
	V	7390.78	2.60	44.00	54.00	10.00	PK
H	H	2460.72	34.70	102.50	/	/	PK
	V	55.27	8.30	34.80	40.00	5.20	PK
	H	319.64	16.10	45.00	46.00	1.00	PK
	V	589.84	21.60	41.50	46.00	4.50	PK
	H	2483.50	34.70	62.20	74.00	11.80	PK
	H	2483.50	34.70	42.60	54.00	11.40	AV
	H	3280.56	-7.70	51.00	54.00	3.00	PK
	H	4921.84	-3.30	57.10	74.00	16.90	PK

	H	4921.67	-3.30	52.90	54.00	1.10	AV
--	---	---------	-------	-------	-------	------	----

Mode 802.11g

CH	Antenna	Frequency (MHz)	Correct Factor (dB/m)	Corrected Reading (dBuV/m)	Limit (dBuV/m)	Margin (dB)	Detector
L	H	2413.83	34.50	103.70	/	/	PK
	V	55.27	8.30	34.80	40.00	5.20	PK
	H	319.64	16.10	45.00	46.00	1.00	PK
	V	589.84	21.60	41.50	46.00	4.50	PK
	H	2390.00	34.40	65.70	74.00	8.30	PK
	H	2390.00	34.40	45.90	54.00	8.10	AV
	H	3210.42	-8.00	51.30	54.00	2.70	PK
	H	4823.64	-3.50	56.20	74.00	17.80	PK
	H	4823.53	-3.50	45.40	54.00	8.60	AV
M	H	2440.29	34.60	104.10	/	/	PK
	V	55.27	8.30	34.80	40.00	5.20	PK
	H	319.64	16.10	45.00	46.00	1.00	PK
	V	589.84	21.60	41.50	46.00	4.50	PK
	H	3244.93	-7.80	51.90	54.00	2.10	PK
	H	4881.90	-3.40	56.70	74.00	17.30	PK
	H	4881.90	-3.40	45.50	54.00	8.50	AV
	V	7348.69	2.50	44.30	54.00	9.70	PK
H	H	2463.53	34.70	103.50	/	/	PK
	V	55.27	8.30	34.80	40.00	5.20	PK
	H	319.64	16.10	45.00	46.00	1.00	PK
	V	589.84	21.60	41.50	46.00	4.50	PK
	H	2483.50	34.70	72.80	74.00	1.20	PK
	H	2483.50	34.70	52.90	54.00	1.10	AV
	H	3280.56	-7.70	50.50	54.00	3.50	PK
	H	4921.84	-3.30	52.30	74.00	21.70	PK

Mode 802.11n20

CH	Antenna	Frequency (MHz)	Correct Factor (dB/m)	Corrected Reading (dBuV/m)	Limit (dBuV/m)	Margin (dB)	Detector
L	H	2410.22	34.50	105.00	/	/	PK
	V	55.27	8.30	34.80	40.00	5.20	PK
	H	319.64	16.10	45.00	46.00	1.00	PK
	V	589.84	21.60	41.50	46.00	4.50	PK
	H	2390.00	34.40	65.30	74.00	8.70	PK
	H	2390.00	34.40	45.50	54.00	8.50	AV
	H	3210.42	-8.00	53.00	54.00	1.00	PK
	H	4823.64	-3.50	55.00	74.00	19.00	PK
	H	4823.53	-3.50	40.60	54.00	13.40	AV
M	H	2440.29	34.60	104.10	/	/	PK
	V	55.27	8.30	34.80	40.00	5.20	PK
	H	319.64	16.10	45.00	46.00	1.00	PK
	V	589.84	21.60	41.50	46.00	4.50	PK
	H	3244.93	-7.80	51.90	54.00	2.10	PK
	H	4881.90	-3.40	55.20	74.00	18.80	PK
	H	4881.90	-3.40	44.80	54.00	9.20	AV
	V	7390.78	2.60	44.70	54.00	9.30	PK
H	H	2460.32	34.70	104.70	/	/	PK
	V	55.27	8.30	34.80	40.00	5.20	PK
	H	319.64	16.10	45.00	46.00	1.00	PK
	V	589.84	21.60	41.50	46.00	4.50	PK
	H	2483.50	34.70	72.70	74.00	1.30	PK
	H	2483.50	34.70	52.70	54.00	1.30	AV
	H	3280.56	-7.70	53.00	54.00	1.00	PK
	H	4921.84	-3.30	50.80	74.00	23.20	PK

- Remark: 1. Correct Factor = Antenna Factor + Cable Loss (-Amplifier, is employed)
 2. Corrected Reading = Original Receiver Reading + Correct Factor
 3. Margin = limit – Corrected Reading

Example: Assuming Antenna Factor = 30.20dB/m, Cable Loss = 2.00dB,
Original Receiver Reading = 10dBuV.
Then Correct Factor = 30.20 + 2.00 = 32.20dB/m; Corrected Reading = 10dBuV +
32.20dB/m = 42.20dBuV/m
Assuming limit = 54dBuV/m, Corrected Reading = 42.20dBuV/m, then Margin =
54 - 42.20 = 11.80dBuV/m

6.5 Measurement uncertainty

Measurement uncertainty of radiated emission (30MHz-1000MHz) is: ± 4.90 dB
Measurement uncertainty of radiated emission (1000MHz-6000MHz) is: ± 5.02 dB
The measurement uncertainty is given with a confidence of 95%, $k=2$.

7. Emission outside the frequency Band

Test result: PASS

7.1 Limit

In any 100 kHz bandwidth outside the frequency band in which the spread spectrum intentional radiator is operating, the radio frequency power that is produced by the intentional radiator shall be at least 20 dB below that in the 100 kHz bandwidth within the band that contains the highest level of the desired power.

7.2 Test Configuration

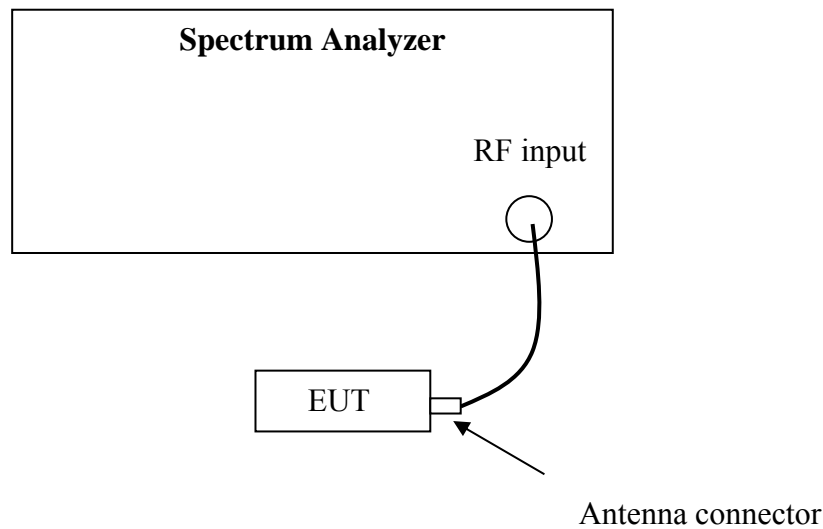

7.3 Test procedure and test setup

The Emission outside the frequency Band per FCC §15.247(d) is measured using the Spectrum Analyzer with the resolutions bandwidth set at 100kHz, the video bandwidth set at 300kHz, and the SPAN>>RBW.

The EUT was tested according to DTS test procedure of “KDB558074 D01 DTS Meas Guidance v03r05” (clause 11.0) for compliance to FCC 47CFR 15.247 requirements.

7.4 Test protocol

Temperature : 25 °C
Relative Humidity : 55 %

802.11b Out-of-Band Emissions – Chain 1

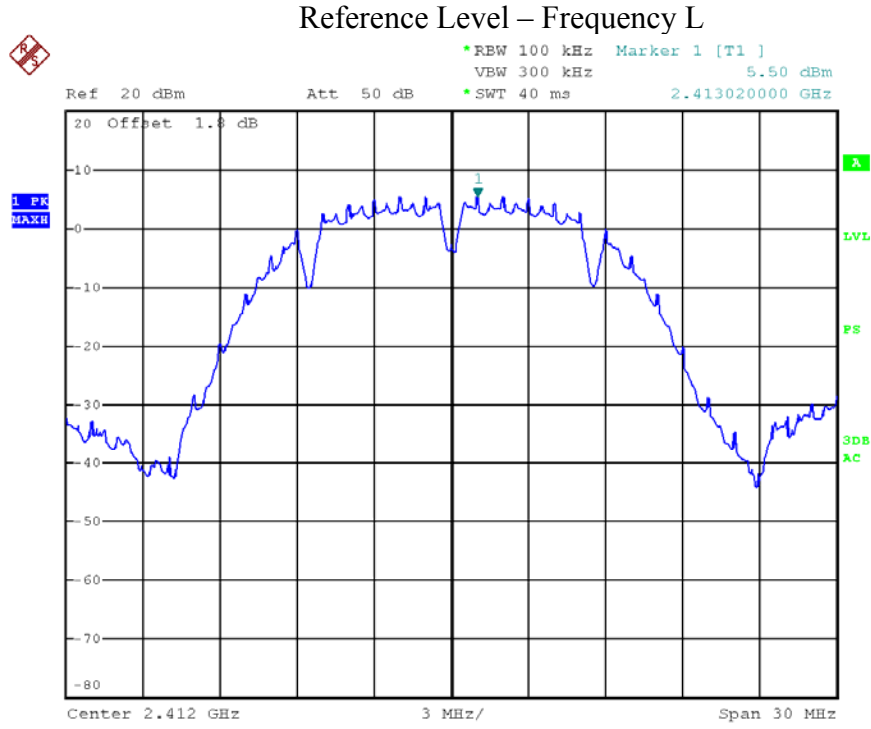

Conducted emission - Frequency L

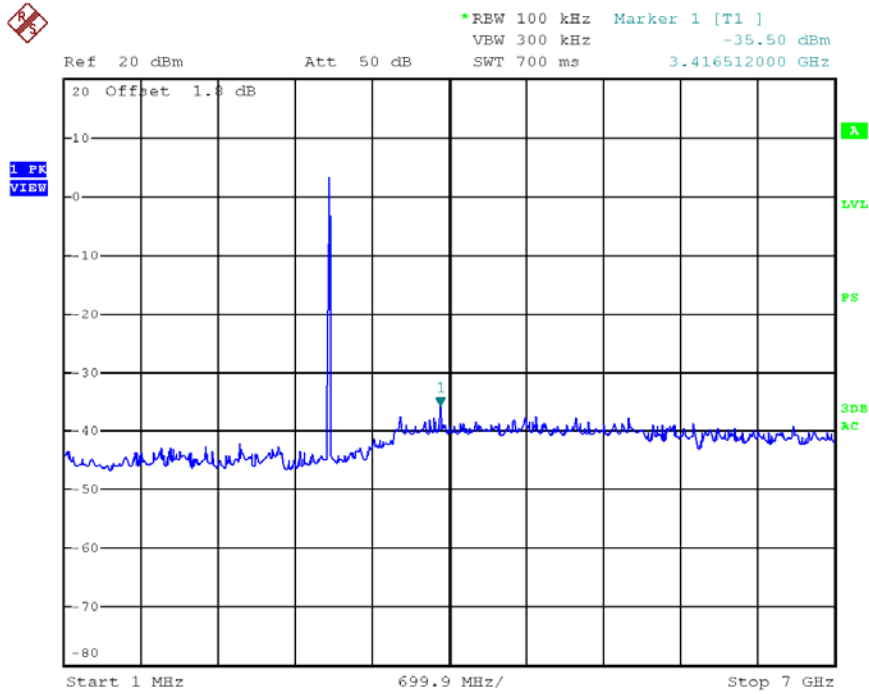
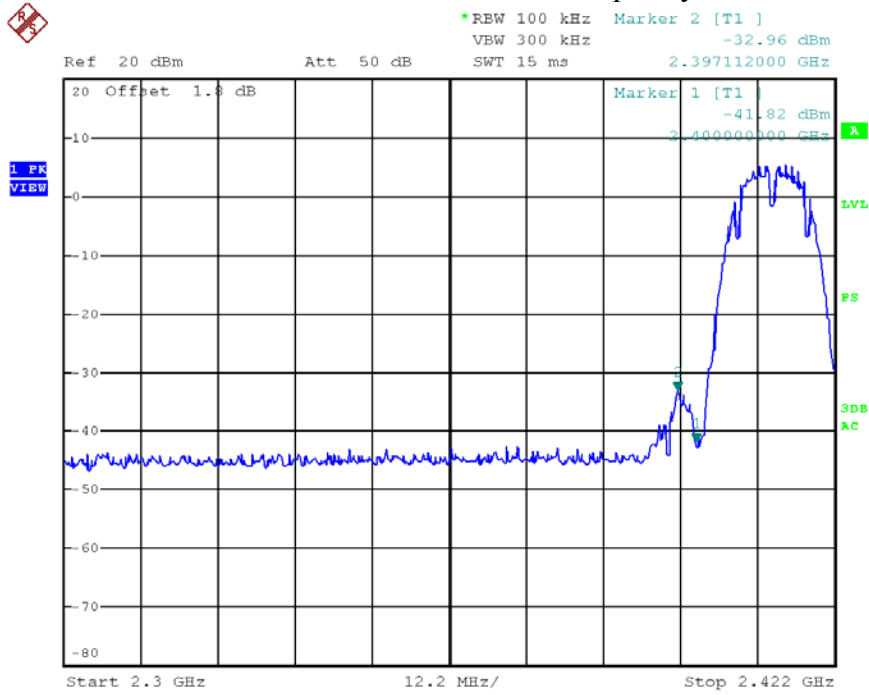

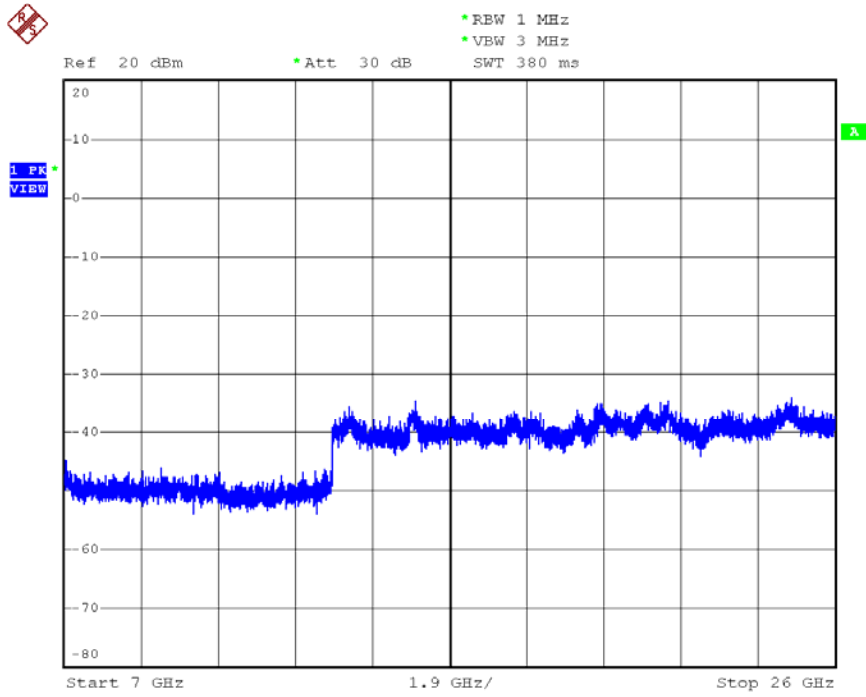

Reference Level – Frequency M

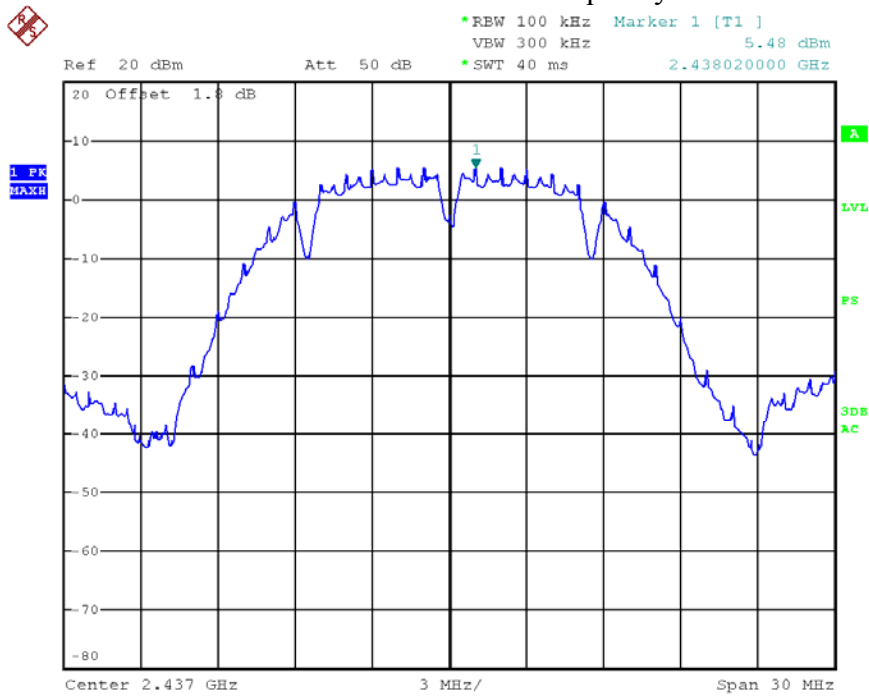

Conducted emission – Frequency M

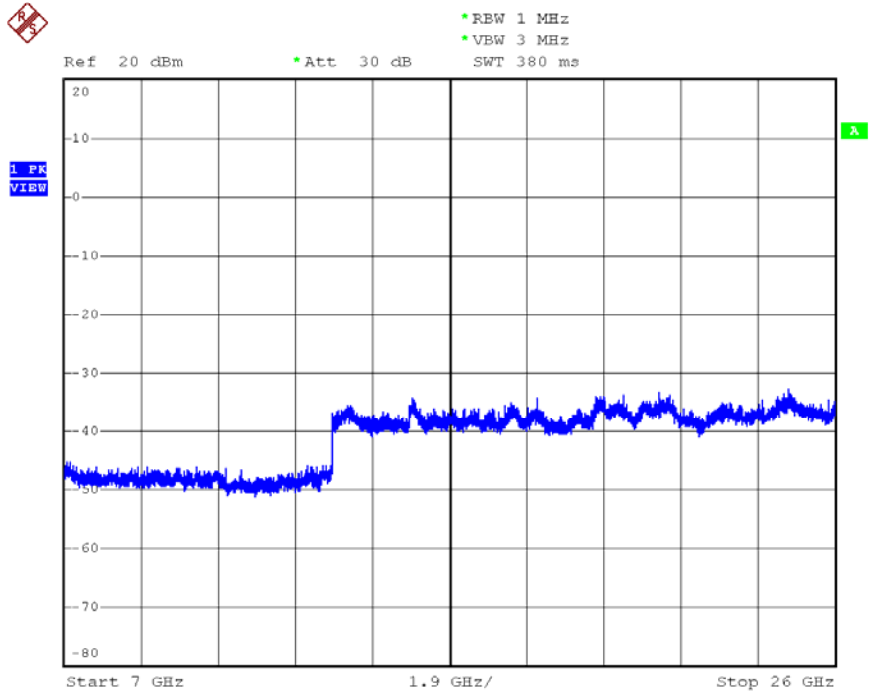
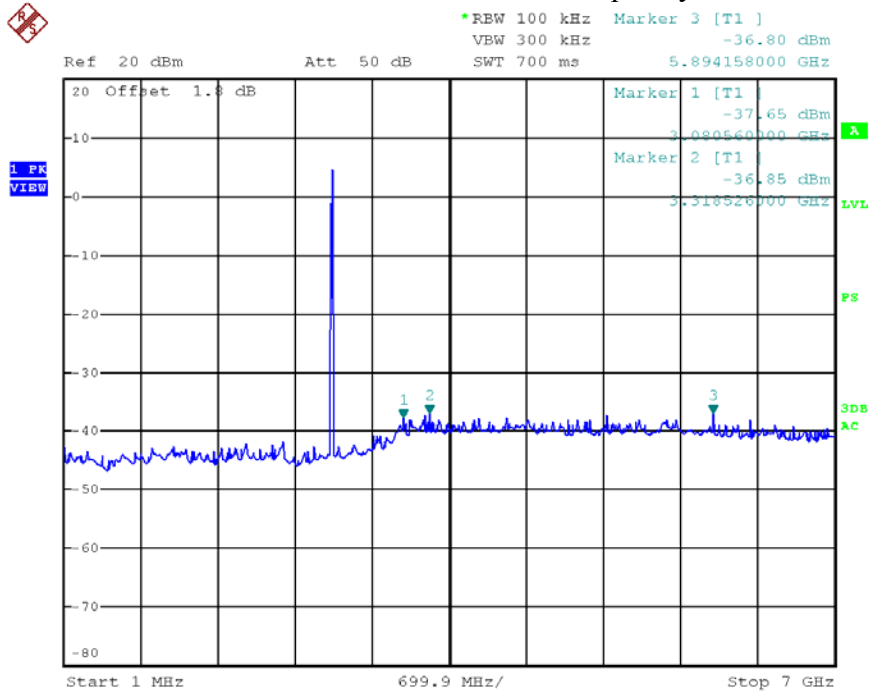

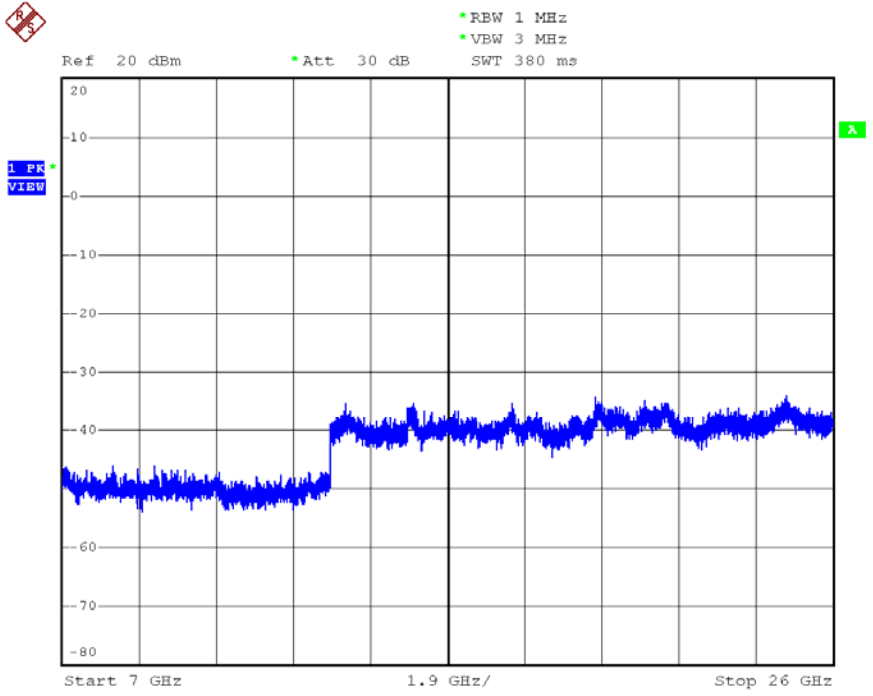
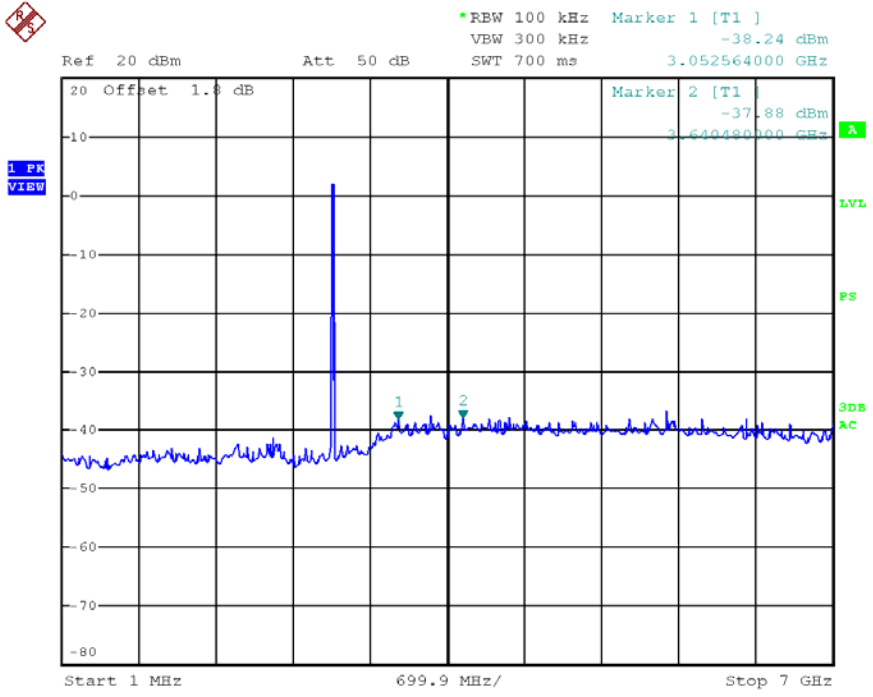

802.11g Out-of-Band Emissions – Chain 1

Reference Level – Frequency L

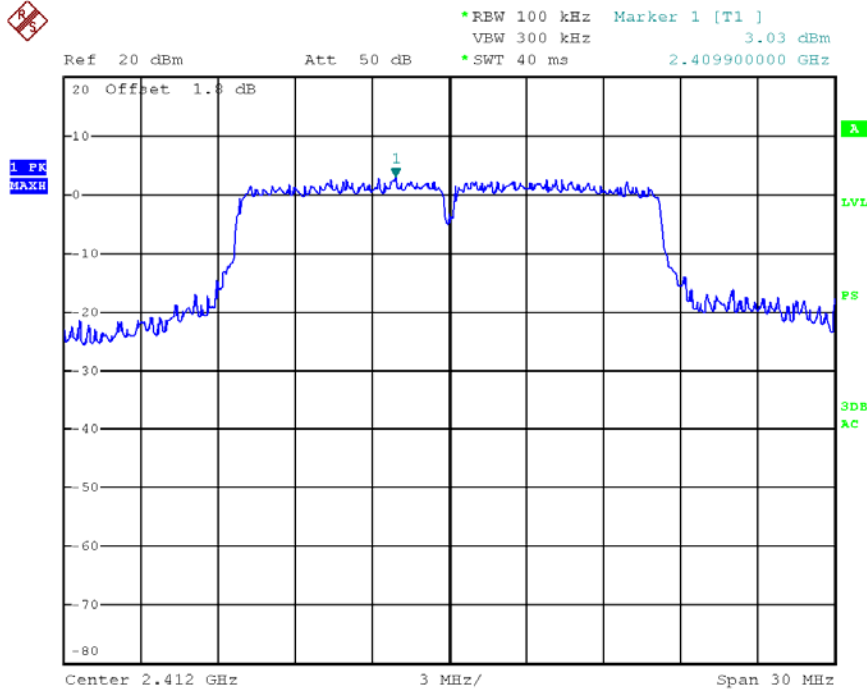

Conducted emission - Frequency L

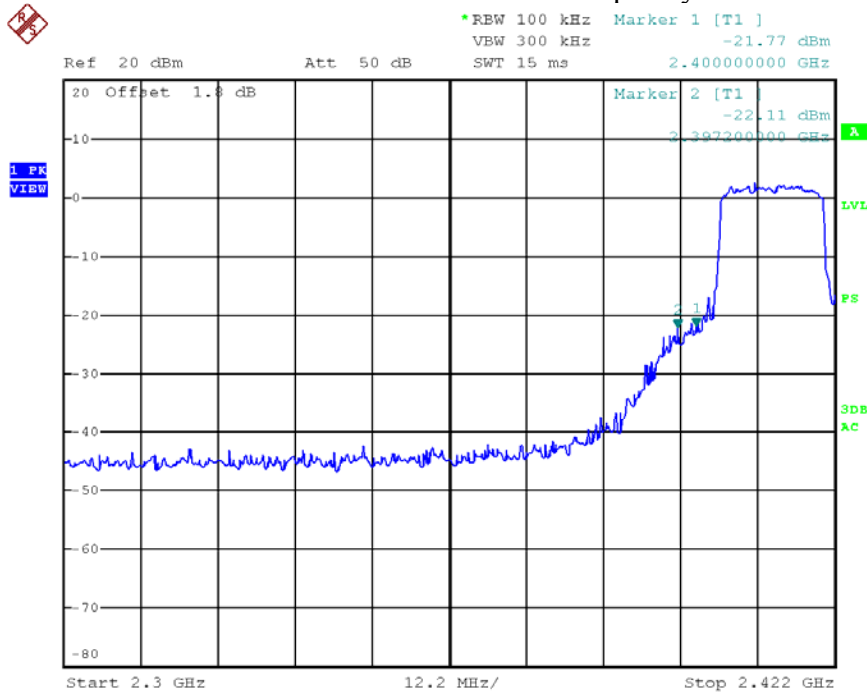

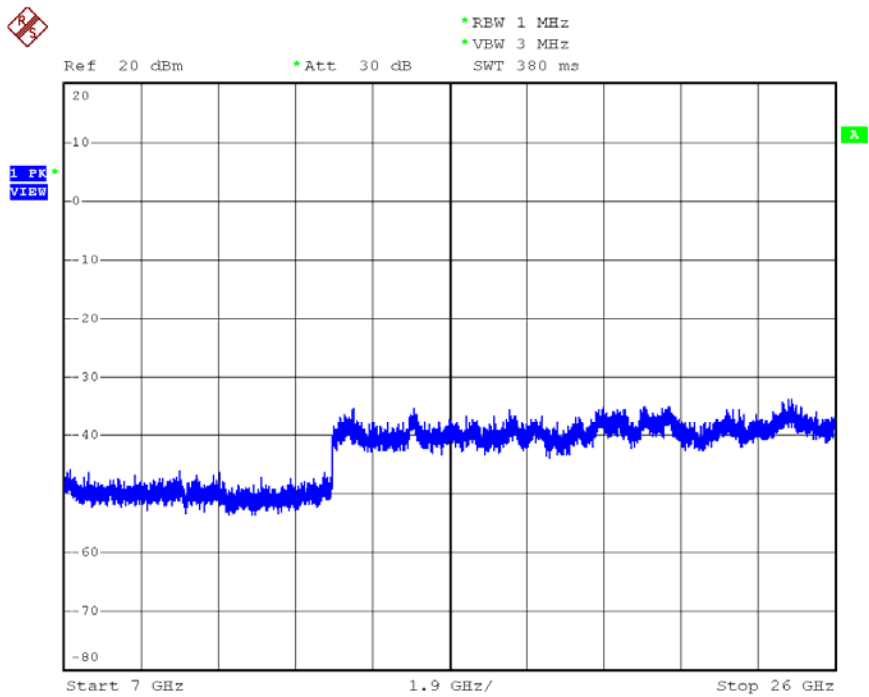
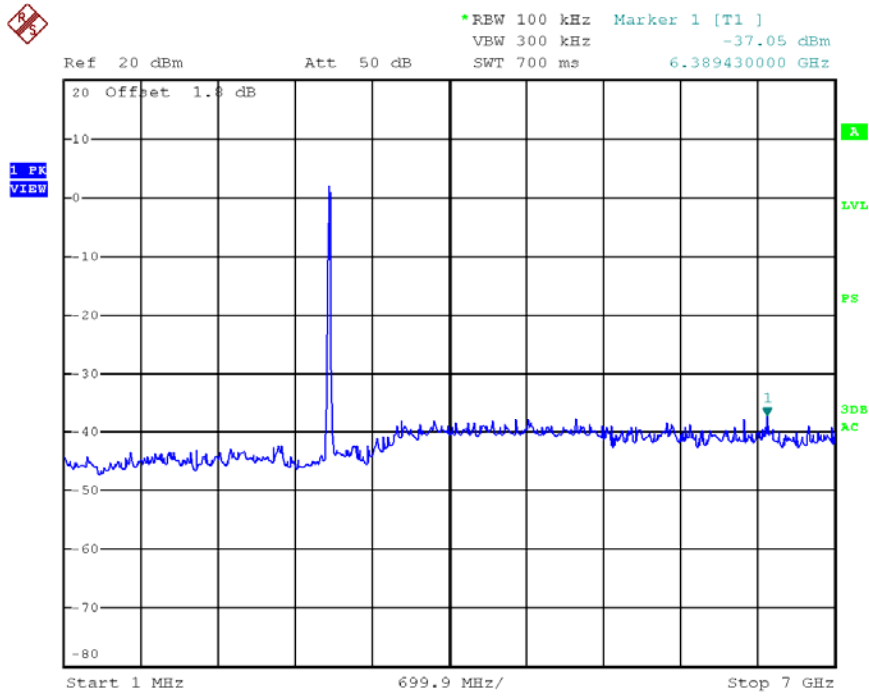

Reference Level – Frequency M

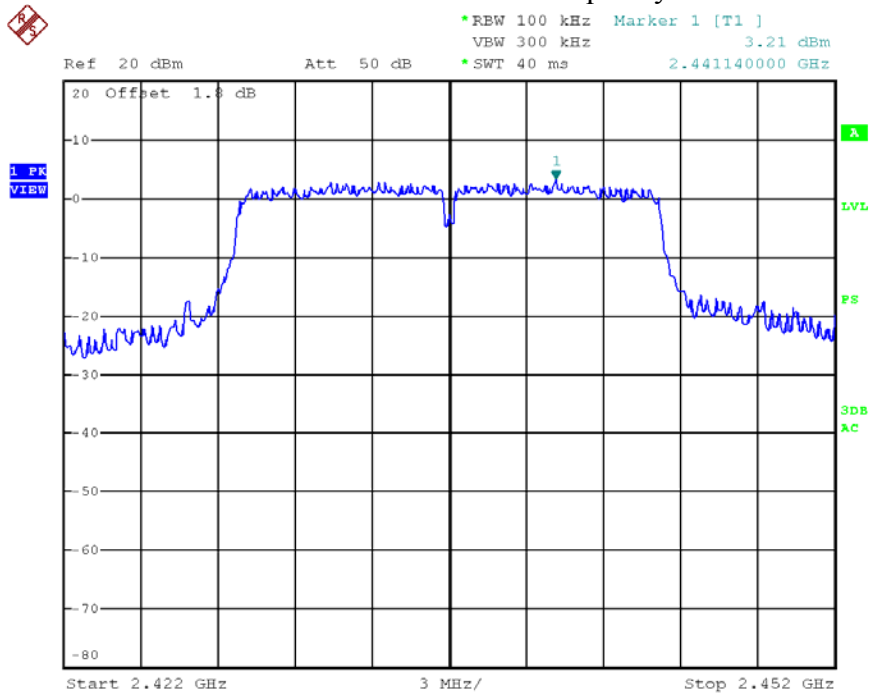

Conducted emission – Frequency M

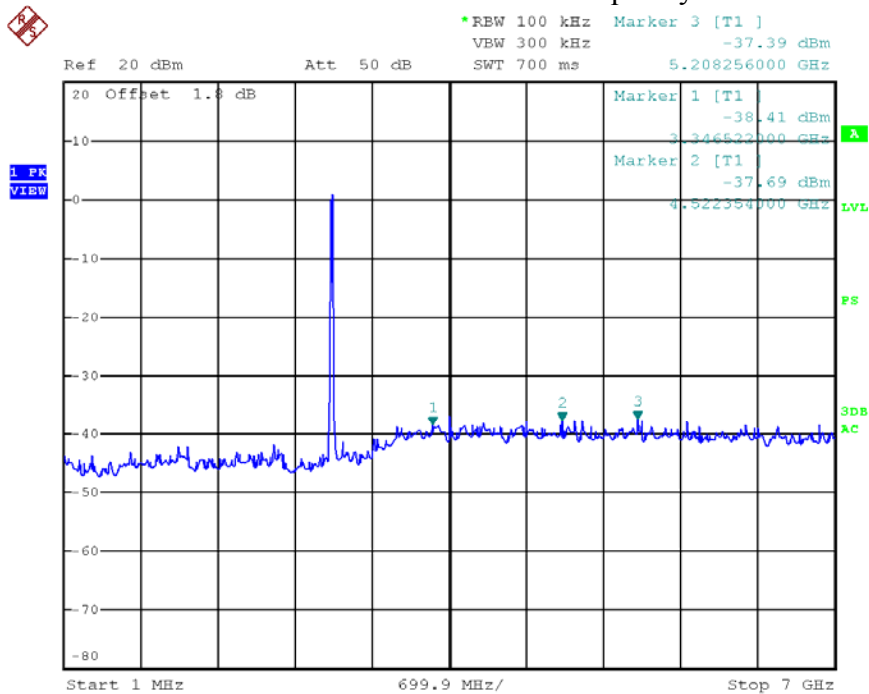

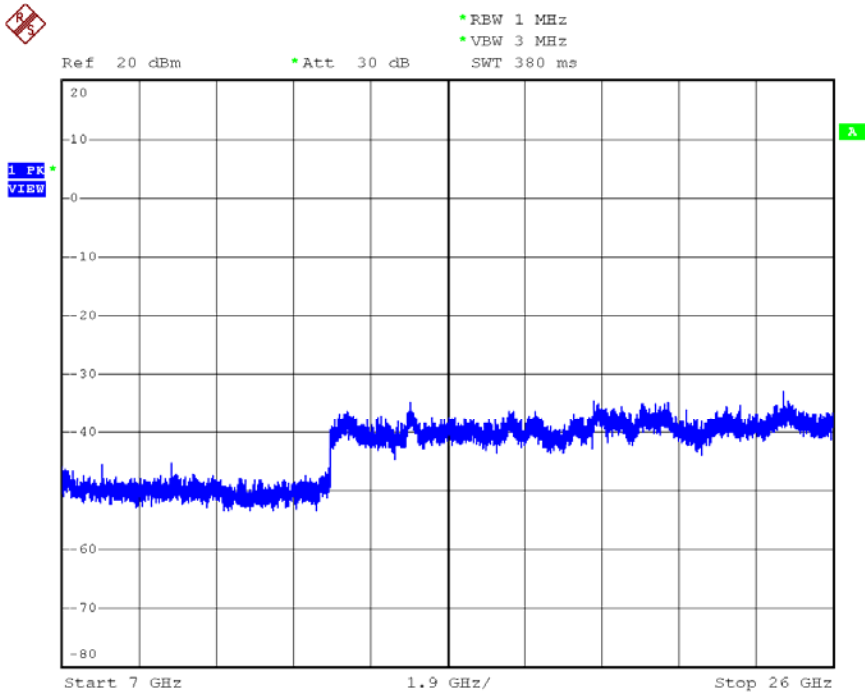

Reference Level – Frequency H

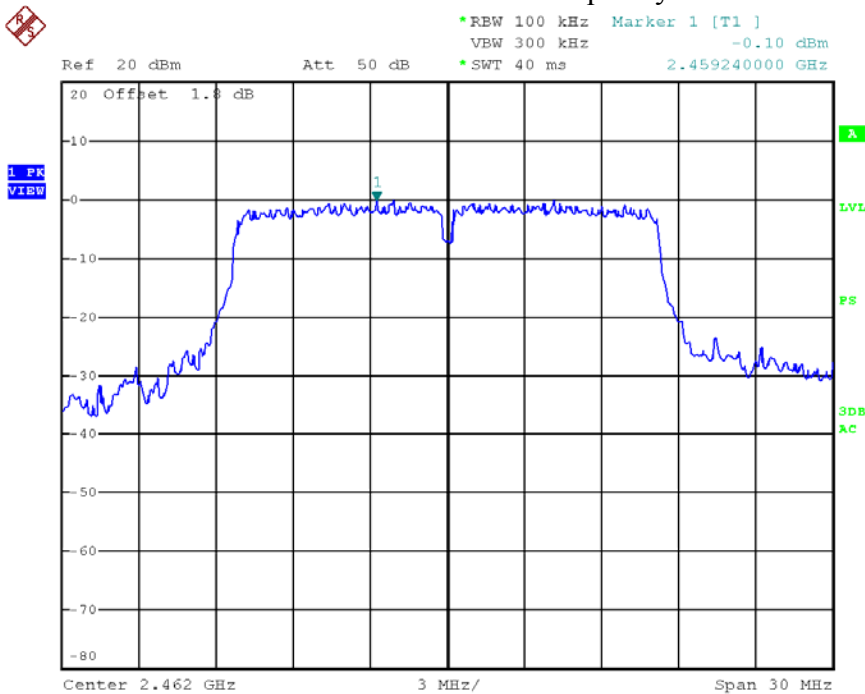

Conducted emission - Frequency H

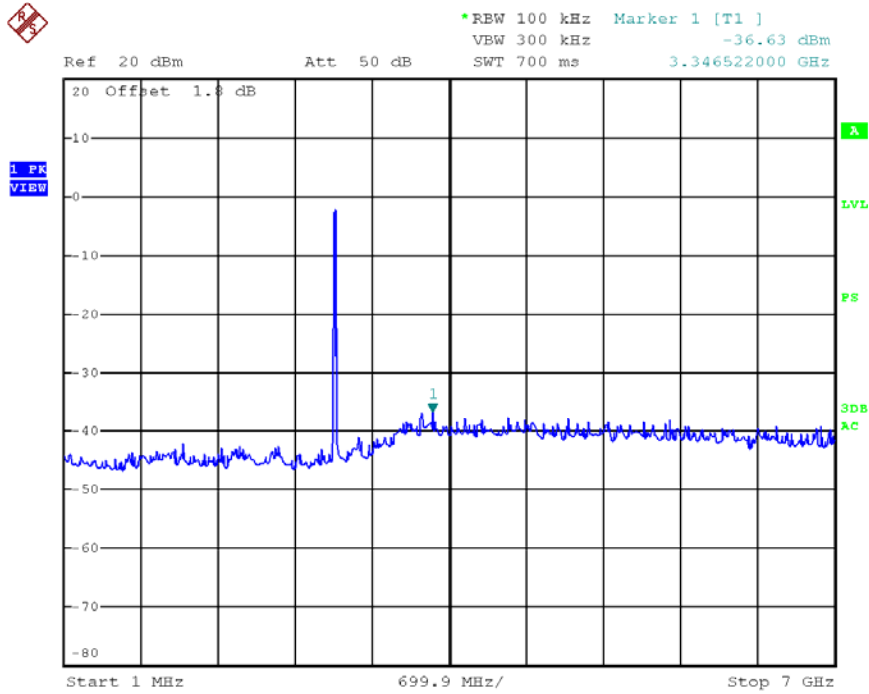
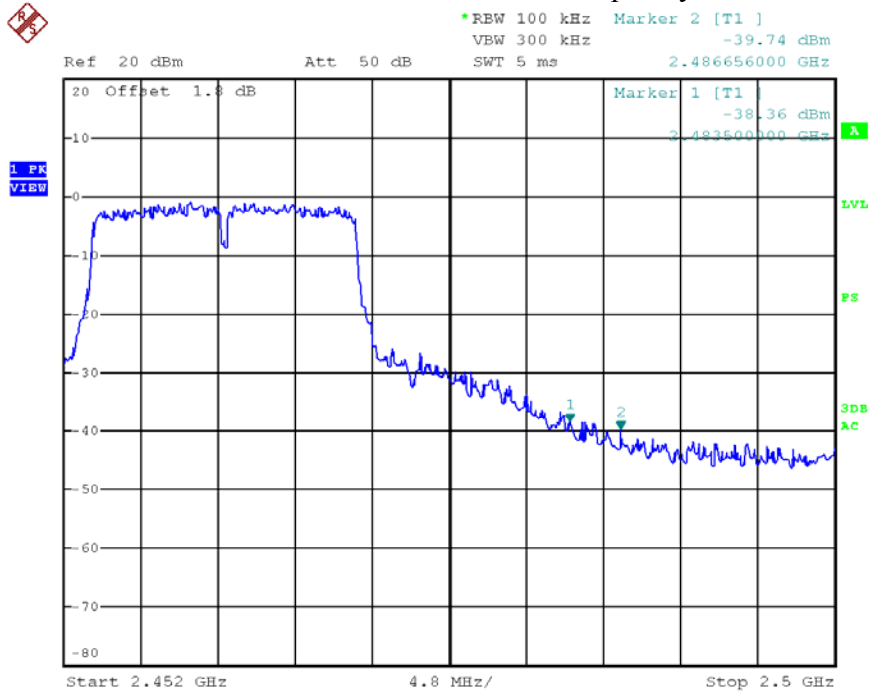

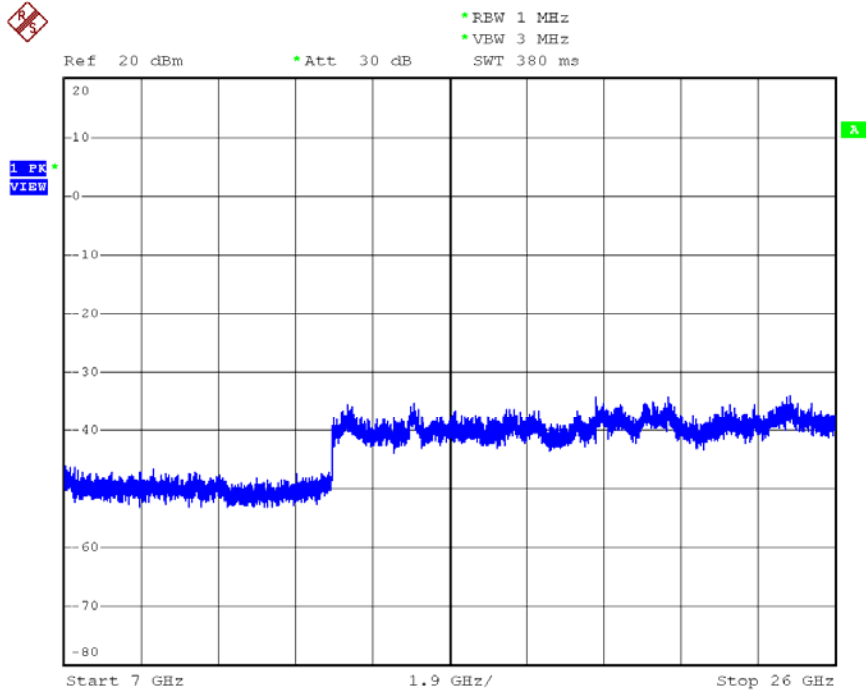

802.11n20 Out-of-Band Emissions – Chain 1

Reference Level – Frequency L

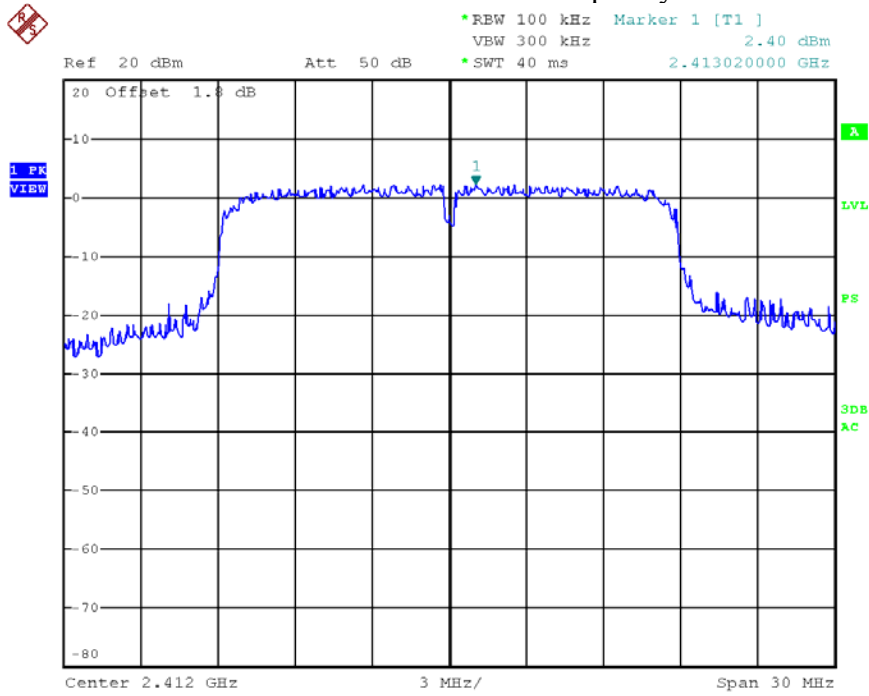

Conducted emission - Frequency L

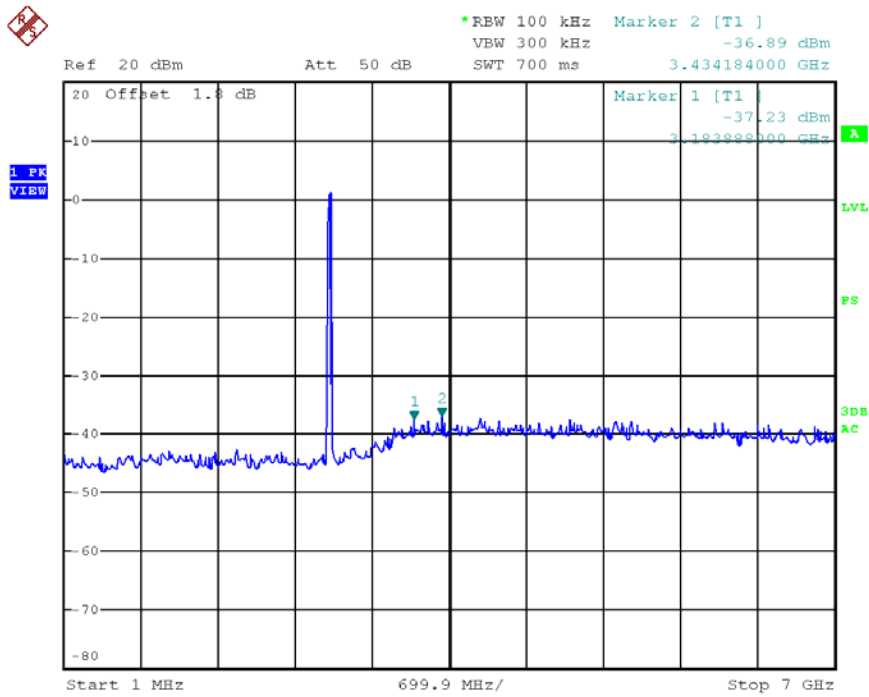
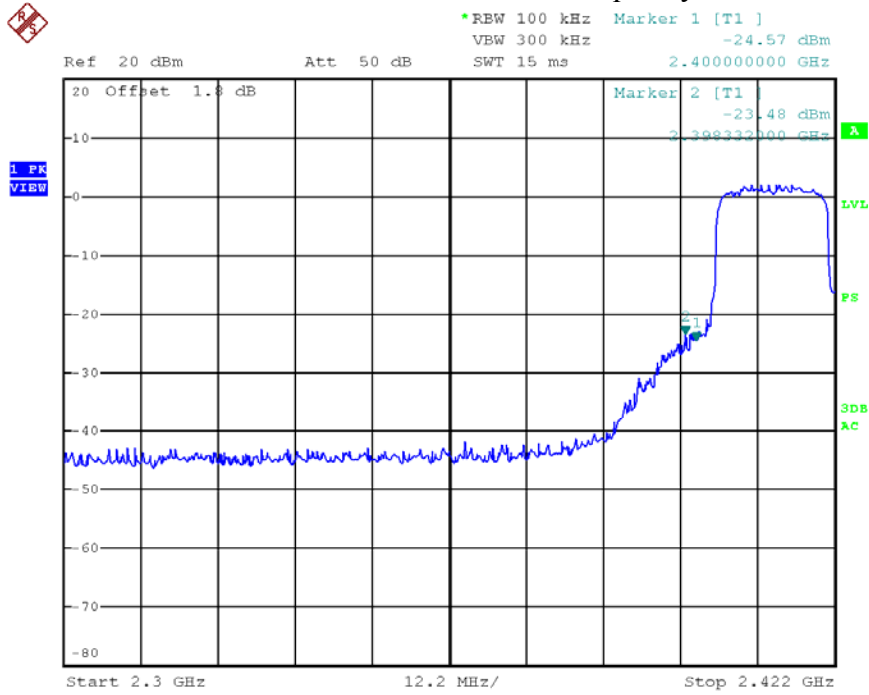

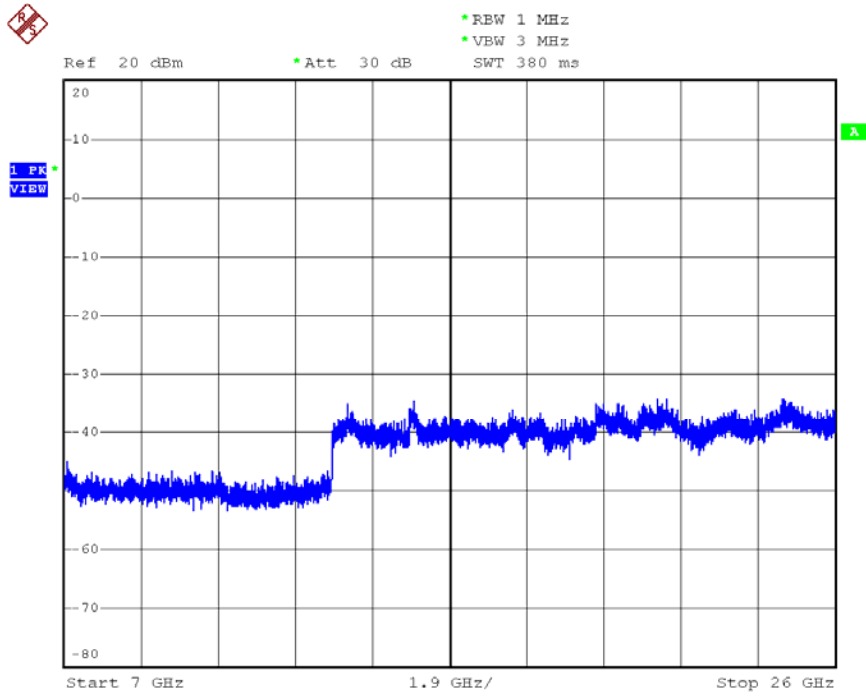

Reference Level – Frequency M

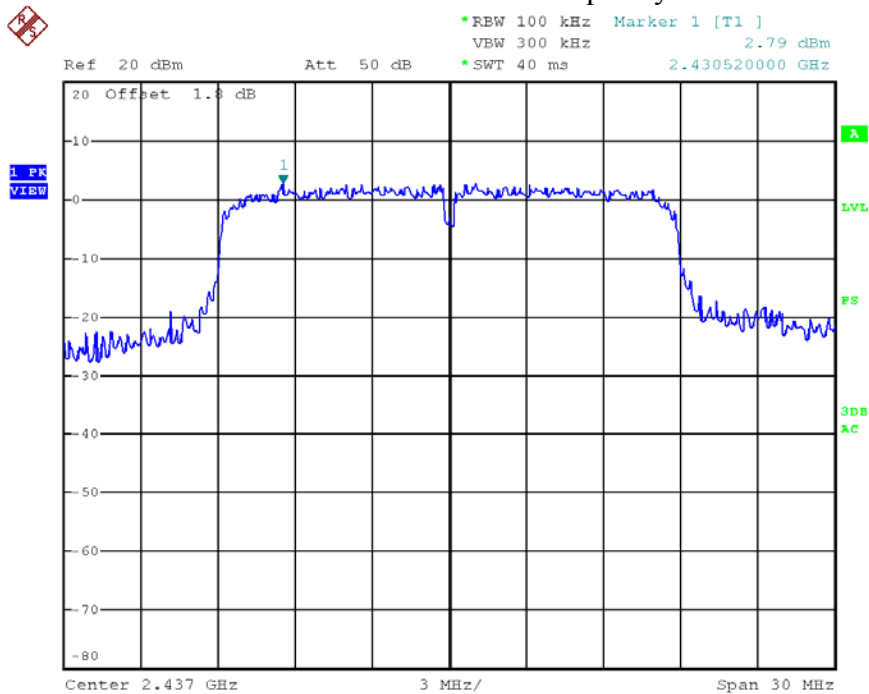

Conducted emission – Frequency M

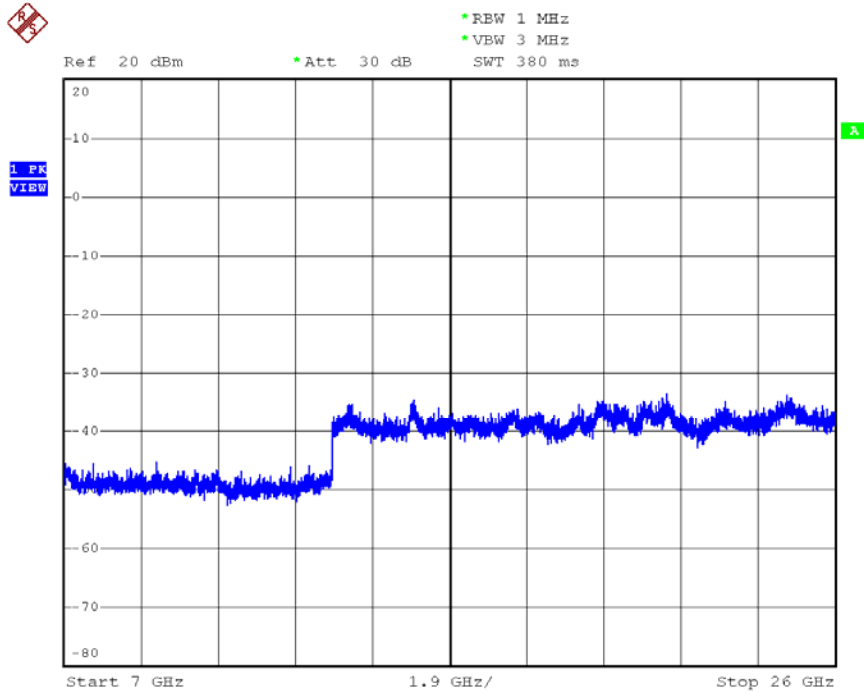
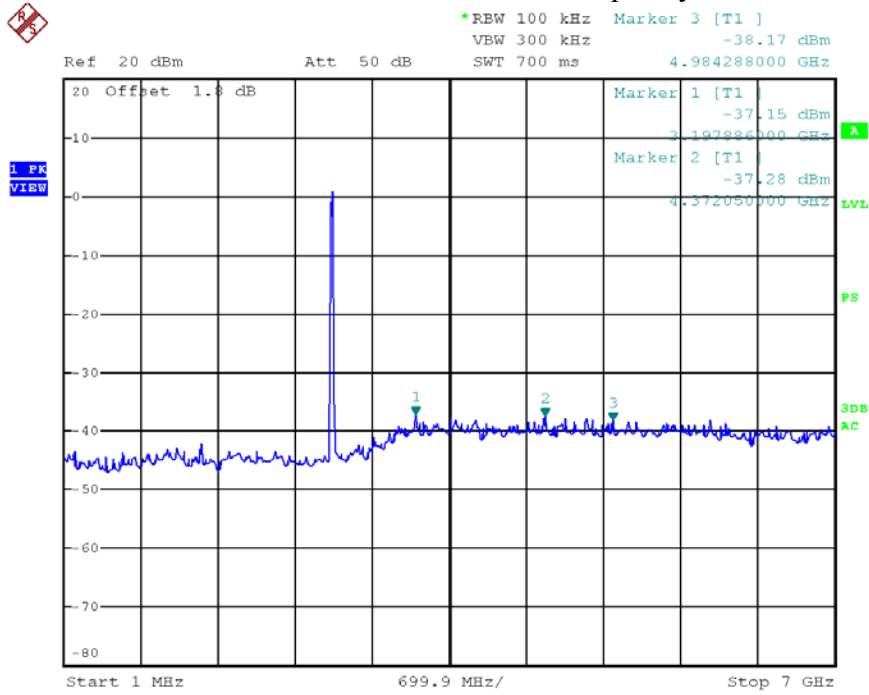

Reference Level – Frequency H

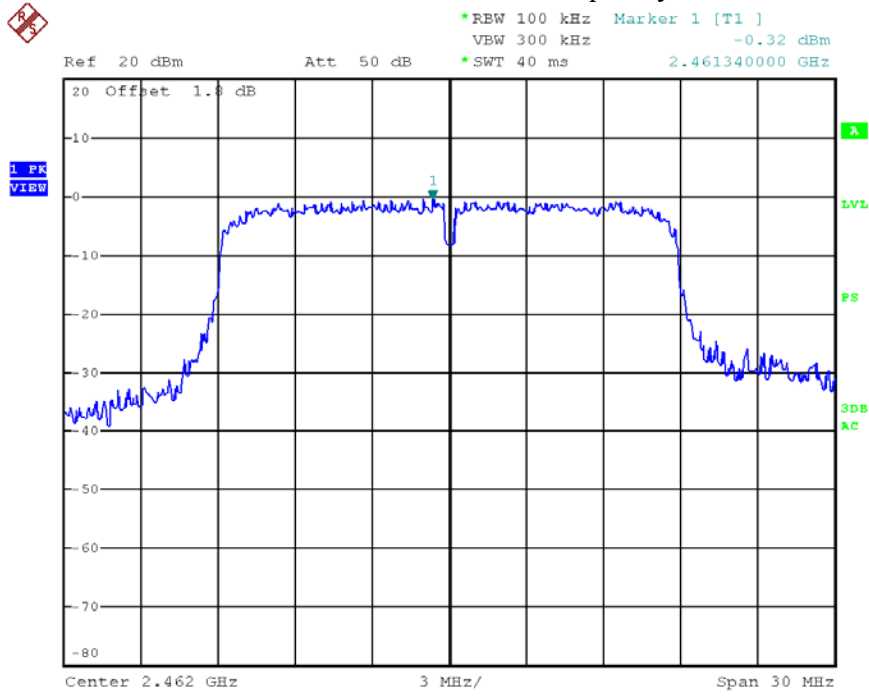

Conducted emission - Frequency H

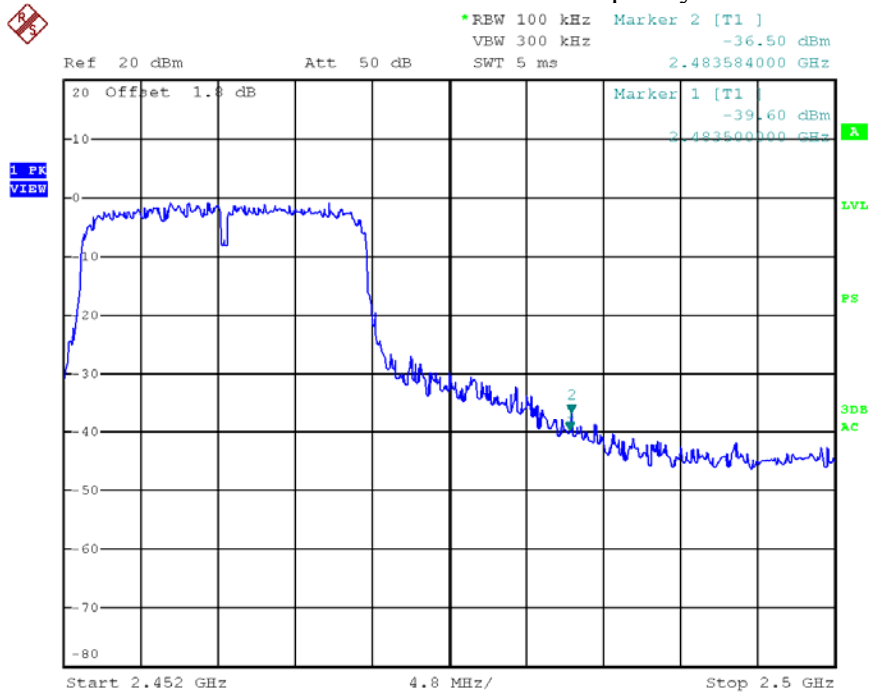

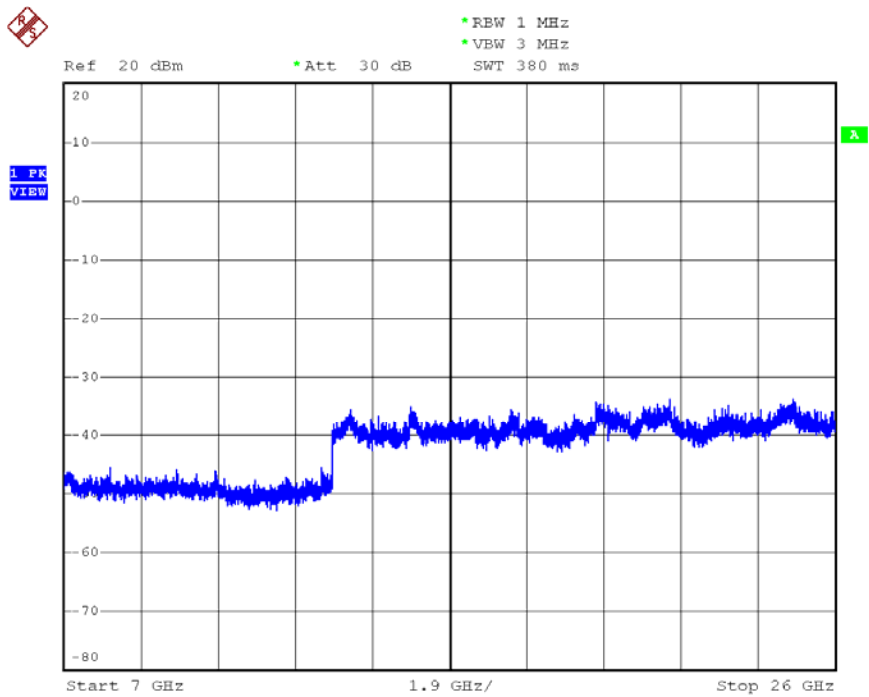
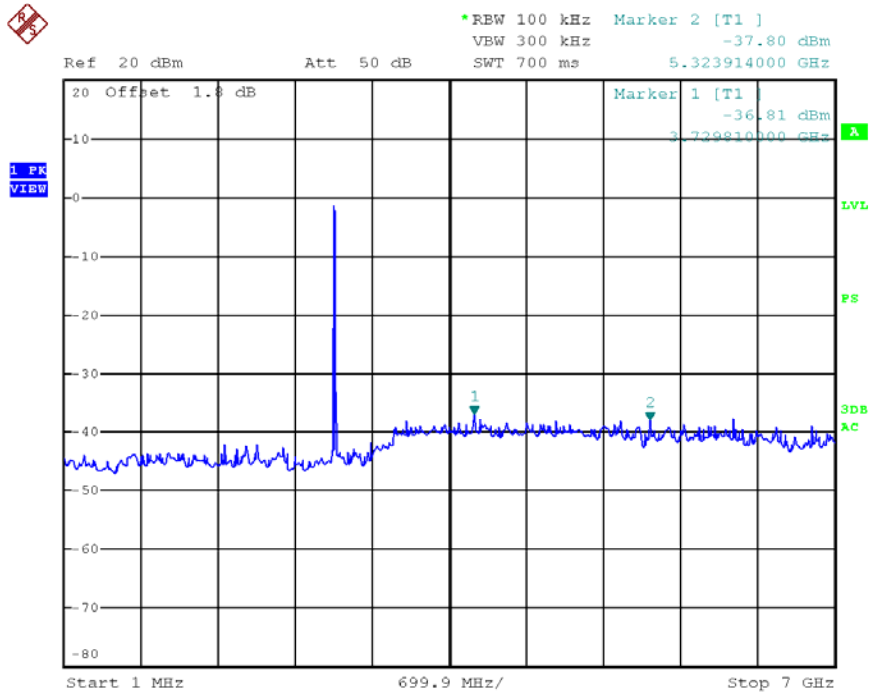

802.11n20 Out-of-Band Emissions – Chain 2

Reference Level – Frequency L

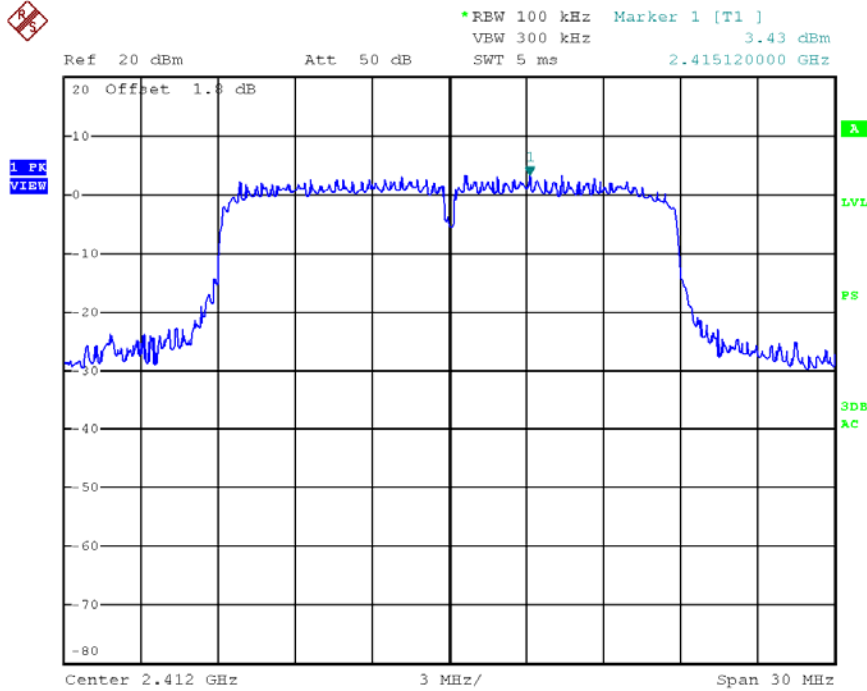

Conducted emission - Frequency L

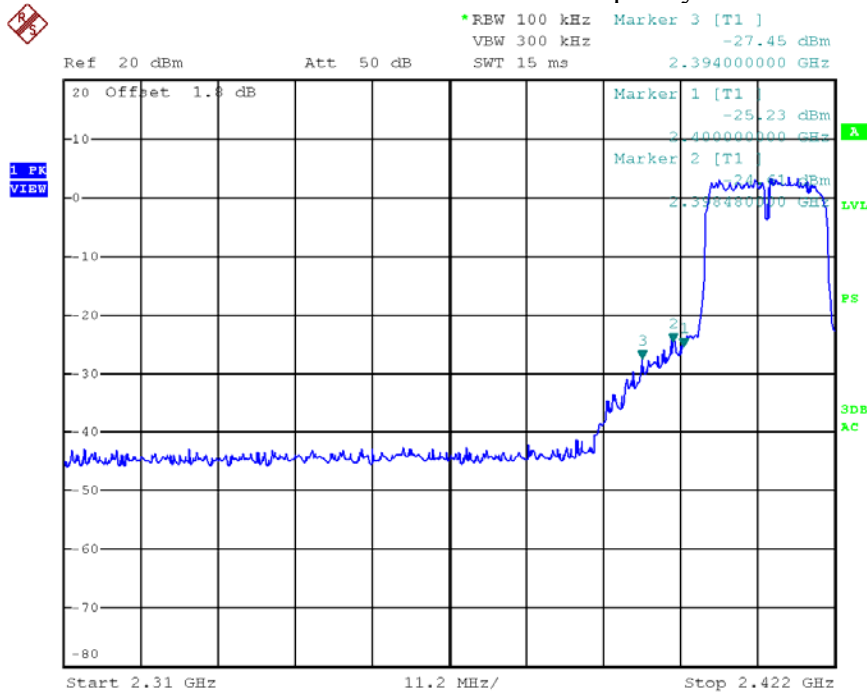

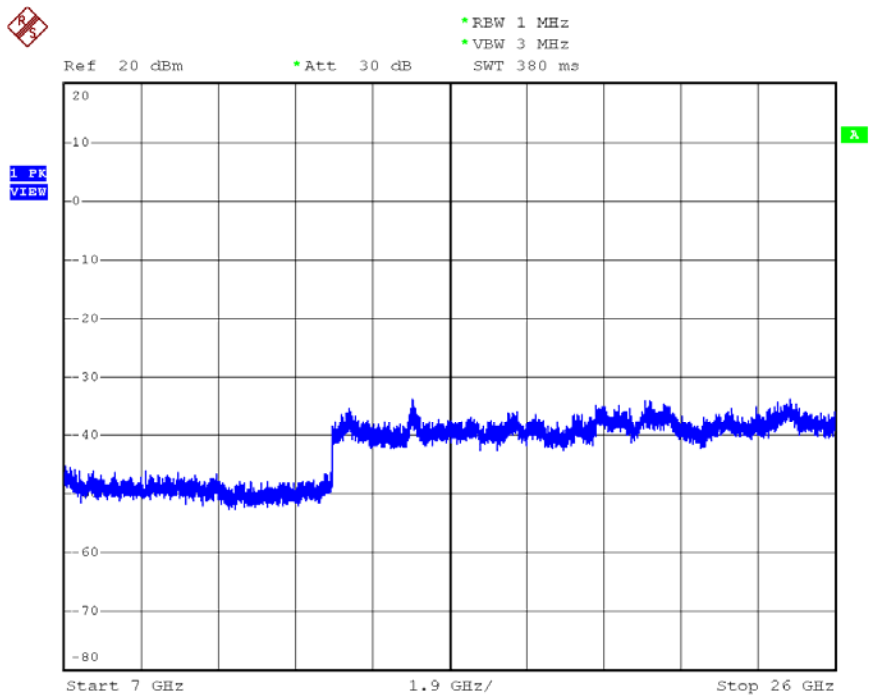
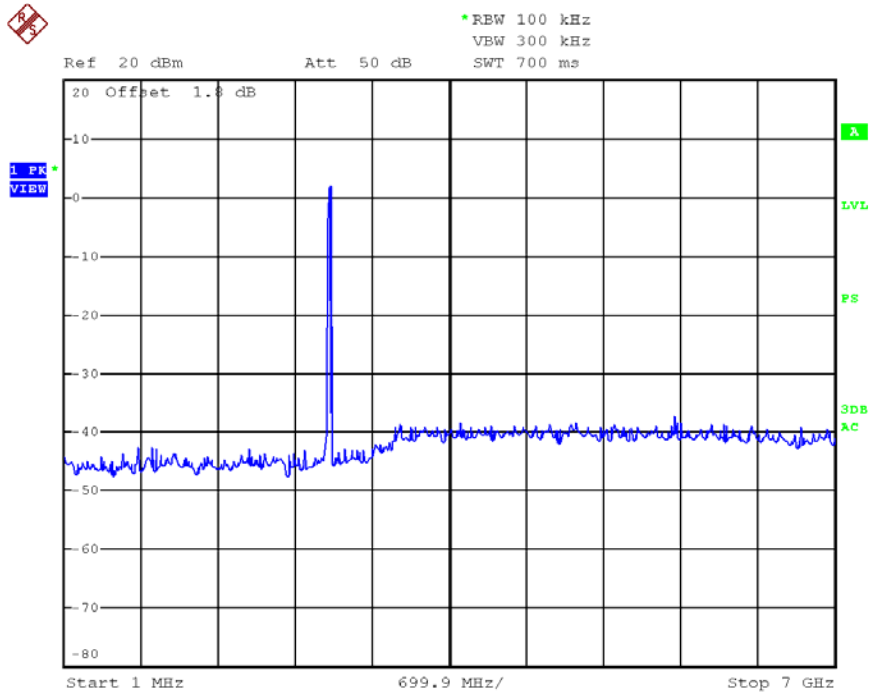

Reference Level – Frequency M

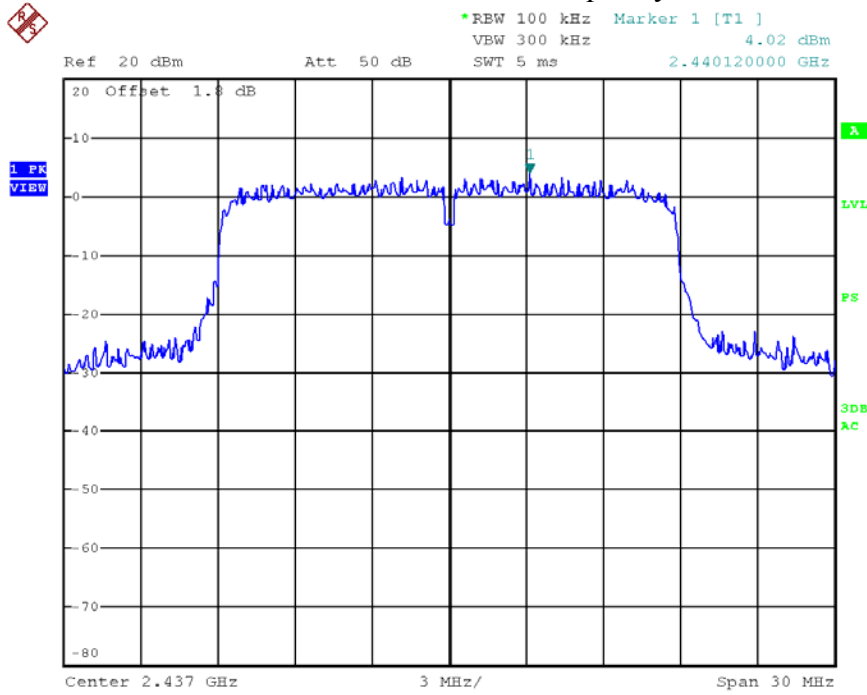

Conducted emission – Frequency M

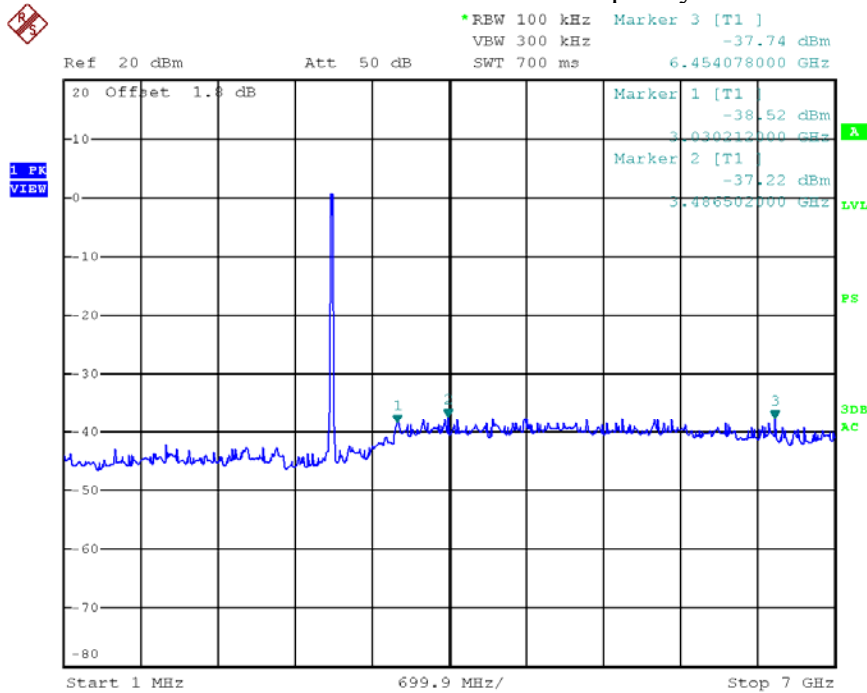

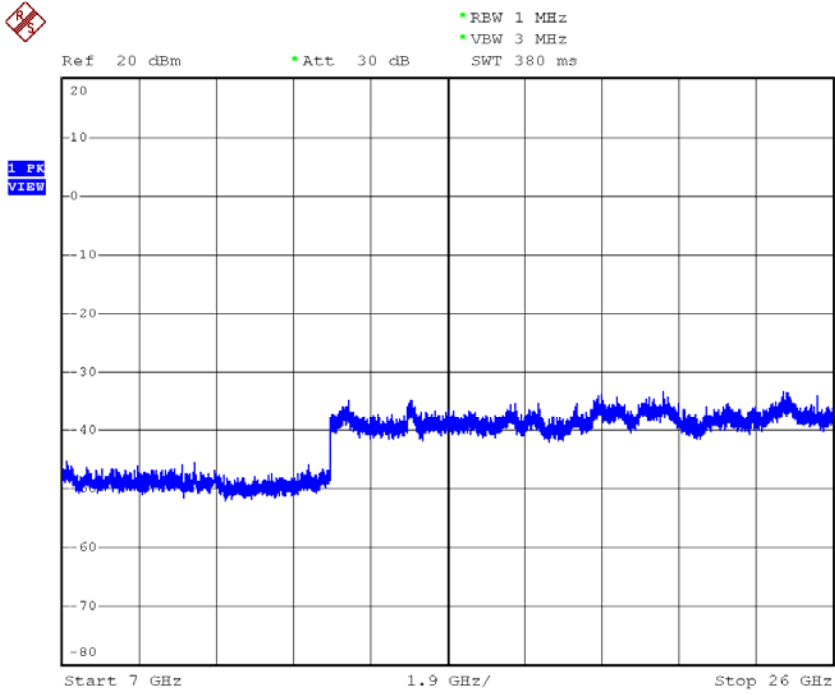

Reference Level – Frequency H

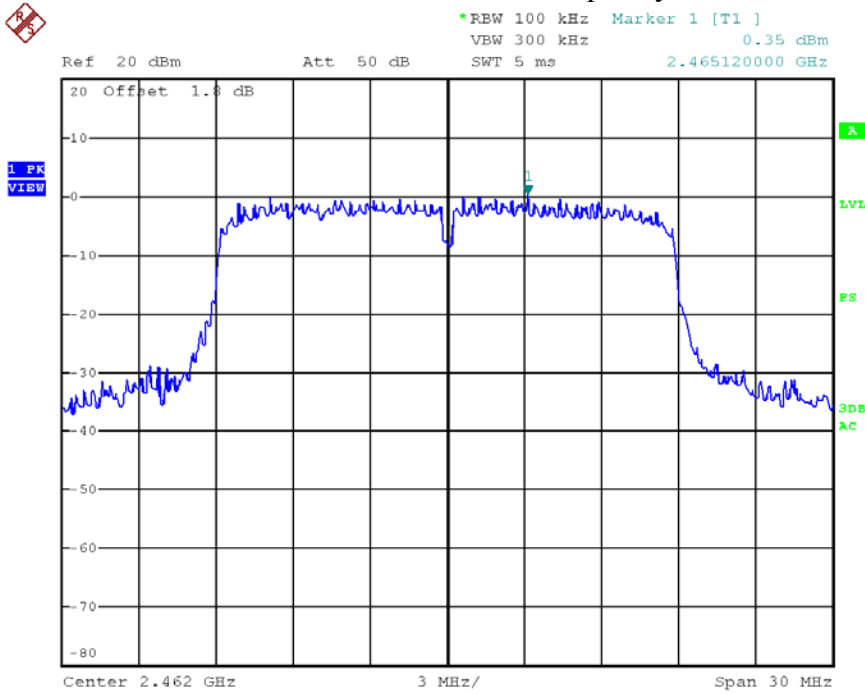

Conducted emission - Frequency H

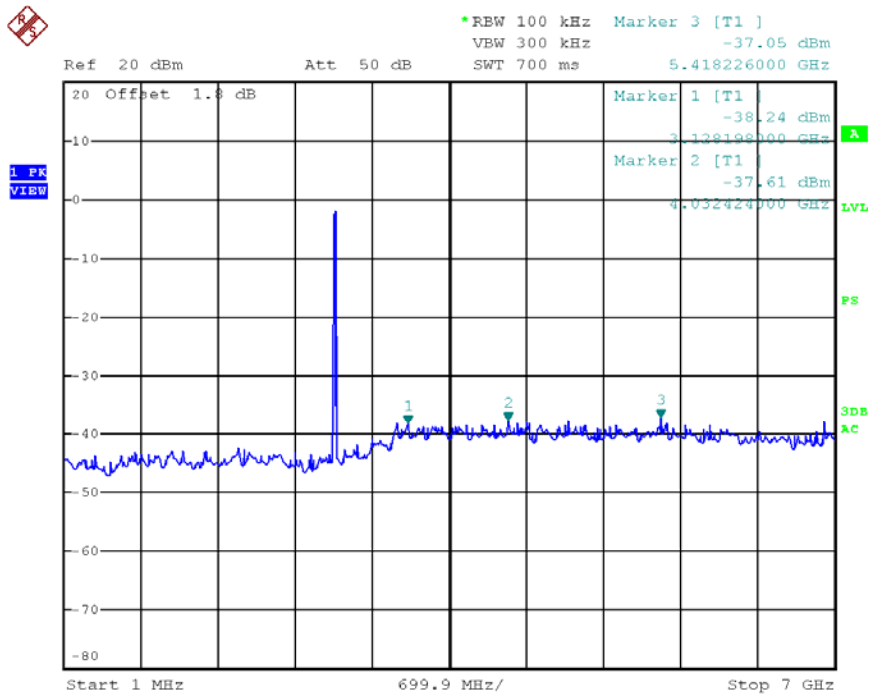
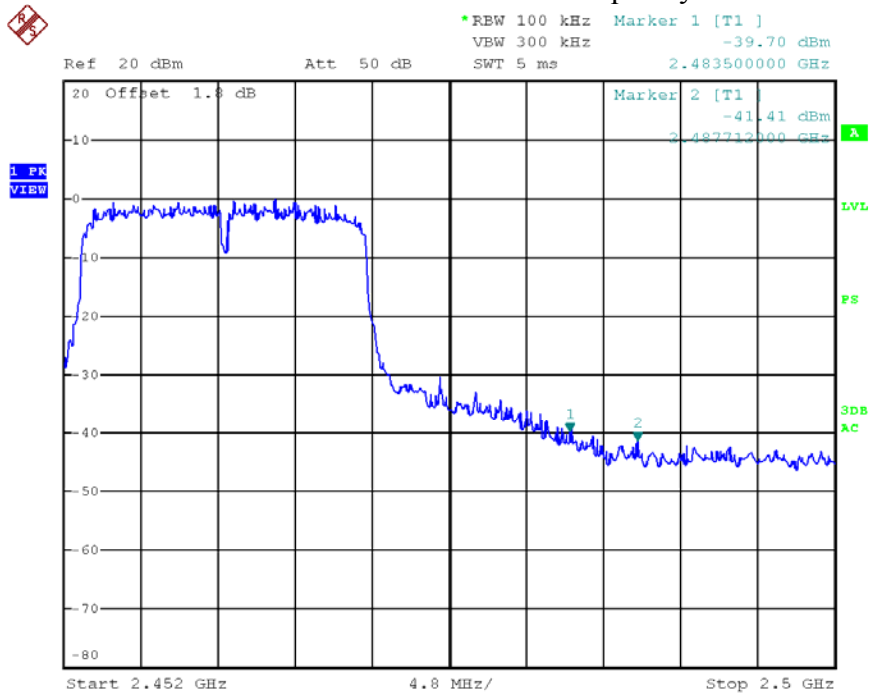

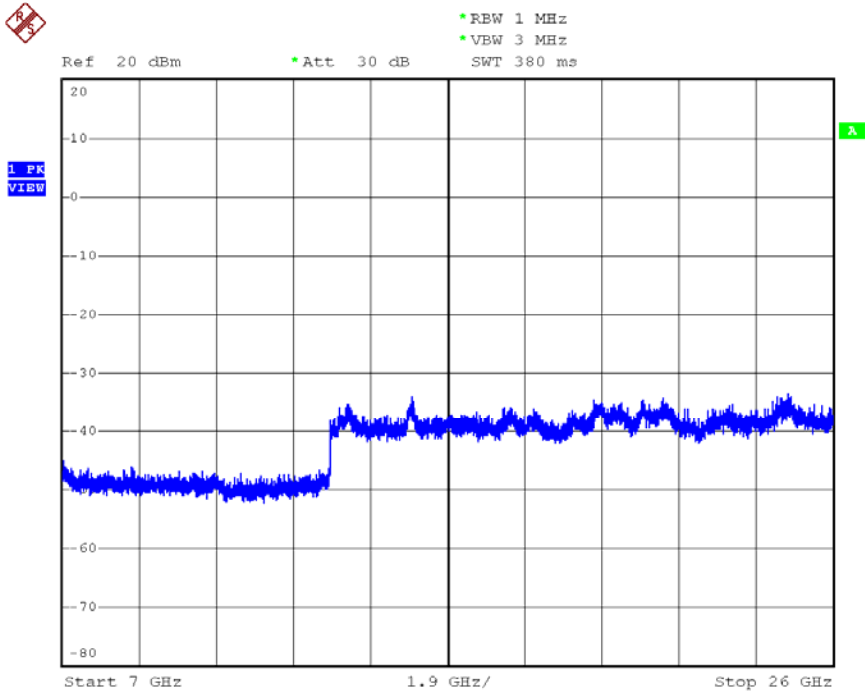

7.5 Measurement uncertainty

Measurement uncertainty: $\pm 0.74\text{dB}$

The measurement uncertainty is given with a confidence of 95%, $k=2$.

8. Power line conducted emission

Test result: Pass

8.1 Limit

Frequency of Emission (MHz)	Conducted Limit (dBuV)	
	QP	AV
0.15-0.5	66 to 56*	56 to 46 *
0.5-5	56	46
5-30	60	50

* Decreases with the logarithm of the frequency.

8.2 Test configuration

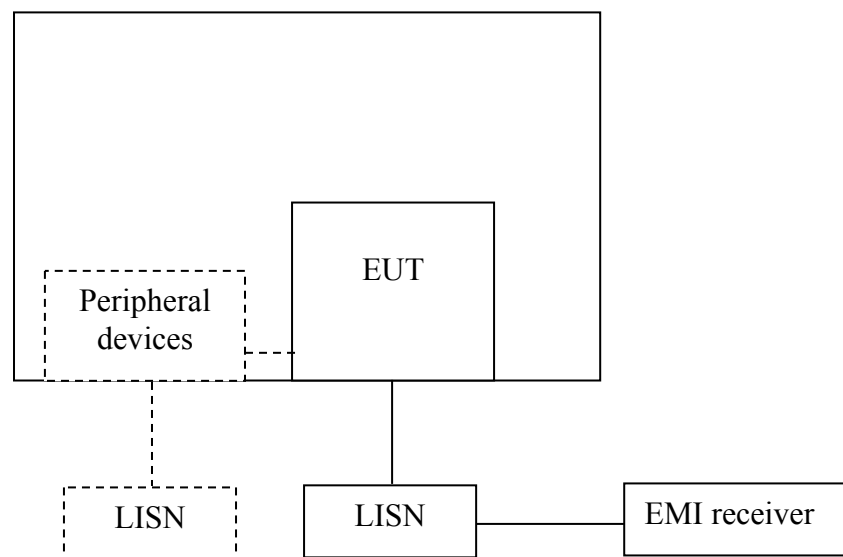

For table top equipment, wooden support is 0.8m height table

For floor standing equipment, wooden support is 0.1m height rack.

8.3 Test procedure and test set up

The EUT are connected to the main power through a line impedance stabilization network (LISN). This provides a $50\Omega/50\mu\text{H}$ coupling impedance for the measuring equipment. The peripheral devices are also connected to the main power through a LISN that provides a $50\Omega/50\mu\text{H}$ coupling impedance with 50Ω termination.

Both sides (Line and Neutral) of AC line are checked for maximum conducted interference. In order to find the maximum emission, the relative positions of equipment and all of the interface cables must be changed according to ANSI C63.4 on conducted measurement. The bandwidth of the test receiver is set at 9 kHz.

8.4 Test protocol

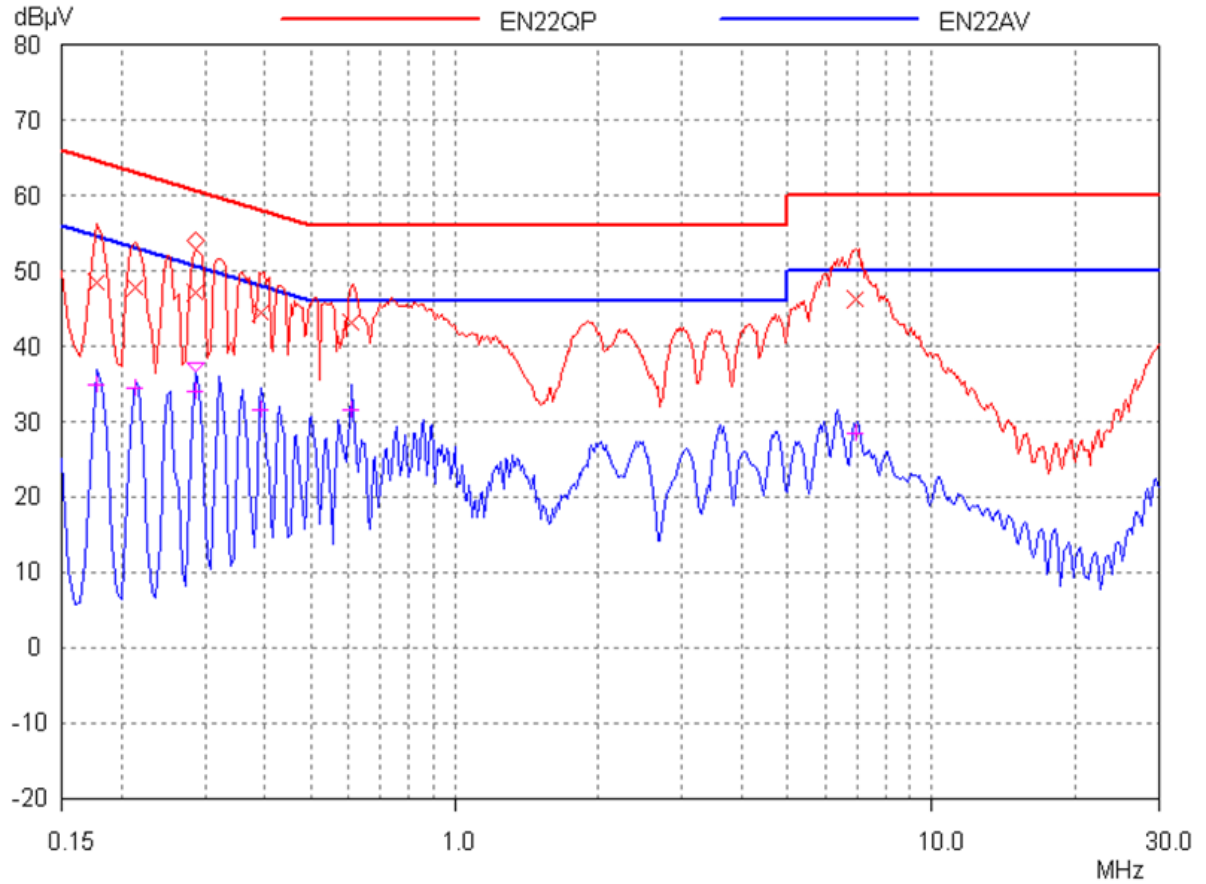

Frequency	Correct Factor (dB)	Corrected Reading (dBµV)		Limit (dBµV)		Margin (dB)	
		QP	AV	QP	AV	QP	AV
0.18 (L)	3.00	48.42	34.97	64.63	54.63	16.21	19.66
0.21 (N)	3.00	47.79	34.42	63.09	53.09	15.30	18.67
0.29 (L)	3.00	47.05	34.11	60.67	50.67	13.62	16.56
0.39 (L)	3.00	44.41	31.51	58.00	48.00	13.59	16.49
0.61 (N)	3.00	43.19	31.49	56.00	46.00	12.81	14.51
6.92 (L)	3.00	46.16	28.48	60.00	50.00	13.84	21.52

Remark: 1. Correction Factor (dB) = LISN Factor (dB) + Cable Loss (dB).
2. Margin (dB) = Limit - Corrected Reading.

8.5 Measurement uncertainty

Measurement uncertainty: $\pm 3.19\text{dB}$

The measurement uncertainty is given with a confidence of 95%, $k=2$.

9. Antenna Requirement

An intentional radiator shall be designed to ensure that no antenna other than that furnished by the responsible party shall be used with the device. The use of a permanently attached antenna or of an antenna that uses a unique coupling to the intentional radiator shall be considered sufficient to comply with the provisions of this section. The manufacturer may design the unit so that a broken antenna can be replaced by the user, but the use of a standard antenna jack or electrical connector is prohibited.

Non-standard connector is used, so fulfill these requirements. Please find more in the photo of EUT.