

ELECTROMAGNETIC EMISSIONS COMPLIANCE REPORT

INTENTIONAL RADIATOR CERTIFICATION TO FCC PART 22 SUBPART H

OF

Product Name: CDMA TS006

Brand Name: Fujitsu Toshiba Mobile Communications Limited

Model Name: TS006

Model Different: N/A

FCC ID: YUW-TS006

Report No.: EH/2010/A0037

Issue Date: Nov. 12, 2010

FCC Rule Part: 2 , 22H

Prepared for: Fujitsu Toshiba Mobile Communications Limited
1-1, Kamikodanaka 4-chome, Nakahara-ku,
Kawasaki

Prepared by: SGS Taiwan Ltd.
Electronics & Communication Laboratory
No. 134, Wu Kung Rd., Wuku Industrial Zone,
Taipei County, Taiwan.

Note: This report shall not be reproduced except in full, without the written approval of SGS Taiwan Ltd. This document may be altered or revised by SGS Taiwan Ltd. personnel only, and shall be noted in the revision section of the document.

Unless otherwise stated the results shown in this test report refer only to the sample(s) tested and such sample(s) are retained for 90 days only. This test report cannot be reproduced, except in full, without prior written permission of the Company. 除非另有說明，此報告結果僅對測試之樣品負責，同時此樣品僅保留 90 天。本報告未經本公司書面許可，不可部份複製。 This document is issued by the Company subject to its General Conditions of Service (www.sgs.com/terms_and_conditions.htm) and Terms and Conditions for Electronic Documents (www.sgs.com/terms_e-document.htm). Attention is drawn to the limitations of liability, indemnification and jurisdictional issues established therein. Even if printed this electronic document is to be treated as an original within the meaning of UCP 600 article 20b. The authenticity of this document may be verified at www.sgsonsite.com/authentication. Any holder of this document is advised that information contained hereon reflects the Company's findings at the time of its intervention only and within the limits of client's instructions, if any. The Company's sole responsibility is to its Client and this document does not exonerate parties to a transaction from exercising all their rights and obligations under the transaction documents.

CERTIFICATION OF COMPLIANCE

Applicant: Fujitsu Toshiba Mobile Communications Limited
 1-1, Kamikodanaka 4-chome, Nakahara-ku, Kawasaki

Product Name: CDMA TS006

Brand Name: Fujitsu Toshiba Mobile Communications Limited

Model No.: TS006

Model Difference: N/A

FCC ID: YUW-TS006

Model Difference: N/A

File Number: EH/2010/A0037

Date of test: Oct. 27, 2010 ~ Nov. 11, 2010

Date of EUT Received: Oct. 27, 2010

We hereby certify that:

The above equipment was tested by SGS Taiwan Ltd. Electronics & Communication Laboratory The test data, data evaluation, test procedures, and equipment configurations shown in this report were made in accordance with the procedures given in TIA/EIA-603-C-2004 and the energy emitted by the sample EUT tested as described in this report is in compliance with conducted and radiated emission limits of FCC Rule PART 22 subpart H.

The test results of this report relate only to the tested sample identified in this report.

Test By: Jazz Huang **Date:** Nov. 12, 2010

Jazz Huang / Engineer

Prepared By: Gigi yeh **Date:** Nov. 12, 2010

Gigi Yeh / Clerk

Approved By: Arno Hsieh **Date:** Nov. 12, 2010

Arno Hsieh / Asst. Supervisor

Unless otherwise stated the results shown in this test report refer only to the sample(s) tested and such sample(s) are retained for 90 days only. This test report cannot be reproduced, except in full, without prior written permission of the Company. 除非另有說明，此報告結果僅對測試之樣品負責，同時此樣品僅保留 90 天。本報告未經本公司書面許可，不可部份複製。 This document is issued by the Company subject to its General Conditions of Service (www.sgs.com/terms_and_conditions.htm) and Terms and Conditions for Electronic Documents (www.sgs.com/terms_e-document.htm). Attention is drawn to the limitations of liability, indemnification and jurisdictional issues established therein. Even if printed this electronic document is to be treated as an original within the meaning of UCP 600 article 20b. The authenticity of this document may be verified at www.sgsonsite.com/authentication. Any holder of this document is advised that information contained hereon reflects the Company's findings at the time of its intervention only and within the limits of client's instructions, if any. The Company's sole responsibility is to its Client and this document does not exonerate parties to a transaction from exercising all their rights and obligations under the transaction documents.

Version

Version No.	Date	Description
00	Nov. 12, 2010	Initial creation of document

Unless otherwise stated the results shown in this test report refer only to the sample(s) tested and such sample(s) are retained for 90 days only. This test report cannot be reproduced, except in full, without prior written permission of the Company. 除非另有說明，此報告結果僅對測試之樣品負責，同時此樣品僅保留 90 天。本報告未經本公司書面許可，不可部份複製。 This document is issued by the Company subject to its General Conditions of Service (www.sgs.com/terms_and_conditions.htm) and Terms and Conditions for Electronic Documents (www.sgs.com/terms_e-document.htm). Attention is drawn to the limitations of liability, indemnification and jurisdictional issues established therein. Even if printed this electronic document is to be treated as an original within the meaning of UCP 600 article 20b. The authenticity of this document may be verified at www.sgsonsite.com/authentication. Any holder of this document is advised that information contained hereon reflects the Company's findings at the time of its intervention only and within the limits of client's instructions, if any. The Company's sole responsibility is to its Client and this document does not exonerate parties to a transaction from exercising all their rights and obligations under the transaction documents.

Table of Contents

1. GENERAL INFORMATION	6
1.1 Product Description	6
1.2 Related Submittal(s) / Grant (s)	8
1.3 Test Methodology	8
1.4 Test Facility	8
1.5 Special Accessories	8
1.6 Equipment Modifications	8
2. SYSTEM TEST CONFIGURATION	9
2.1 EUT Configuration	9
2.2 EUT Exercise	9
2.3 Test Procedure	9
2.4 Measurement Equipment Used:	10
2.5 Configuration of Tested System	12
3. SUMMARY OF TEST RESULTS	13
4. DESCRIPTION OF TEST MODES	13
5. RF POWER OUTPUT MEASUREMENT	14
5.1 Standard Applicable	14
5.2 Test Set-up:	14
5.3 Measurement Procedure	14
5.4 Measurement Equipment Used:	14
5.5 Measurement Result	15
6. ERP/EIRP MEASUREMENT	16
6.1 Standard Applicable	16
6.2 Test SET-UP (Block Diagram of Configuration)	16
6.3 Measurement Procedure	18
6.4 Measurement Equipment Used:	18
6.5 Measurement Result	19
7. 99% OCCUPIED BANDWIDTH MEASUREMENT	20
7.1 Standard Applicable	20
7.2 Test Set-up:	20
7.3 Measurement Procedure	20
7.4 Measurement Equipment Used:	20
7.5 Measurement Result:	21

Unless otherwise stated the results shown in this test report refer only to the sample(s) tested and such sample(s) are retained for 90 days only. This test report cannot be reproduced, except in full, without prior written permission of the Company. 除非另有說明，此報告結果僅對測試之樣品負責，同時此樣品僅保留 90 天。本報告未經本公司書面許可，不可部份複製。 This document is issued by the Company subject to its General Conditions of Service (www.sgs.com/terms_and_conditions.htm) and Terms and Conditions for Electronic Documents (www.sgs.com/terms_e-document.htm). Attention is drawn to the limitations of liability, indemnification and jurisdictional issues established therein. Even if printed this electronic document is to be treated as an original within the meaning of UCP 600 article 20b. The authenticity of this document may be verified at www.sgsonsite.com/authentication. Any holder of this document is advised that information contained hereon reflects the Company's findings at the time of its intervention only and within the limits of client's instructions, if any. The Company's sole responsibility is to its Client and this document does not exonerate parties to a transaction from exercising all their rights and obligations under the transaction documents.

8.	OUT OF BAND EMISSION AT ANTENNA TERMINALS	24
8.1	Standard Applicable	24
8.2	Test SET-UP	24
8.3	Measurement Procedure.....	24
8.4	Measurement Equipment Used:	24
8.5	Measurement Result.....	24
9.	FIELD STRENGTH OF SPURIOUS RADIATION MEASUREMENT (TX).....	29
9.1	Standard Applicable	29
9.2	EUT Setup (Block Diagram of Configuration)	29
9.3	Measurement Procedure.....	29
9.4	Measurement Equipment Used:	29
9.5	Measurement Result.....	29
10.	FREQUENCY STABILITY V.S. TEMPERATURE MEASUREMENT	36
10.1	Standard Applicable	36
10.2	Test Set-up:	36
10.3	Measurement Procedure.....	36
10.4	Measurement Equipment Used:	36
10.5	Measurement Result.....	37
11.	FREQUENCY STABILITY V.S. VOLTAGE MEASUREMENT	38
11.1	Standard Applicable	38
11.2	Test Set-up:	38
11.3	Measurement Procedure.....	38
11.4	Measurement Equipment Used:	38
11.5	Measurement Result.....	39

Unless otherwise stated the results shown in this test report refer only to the sample(s) tested and such sample(s) are retained for 90 days only. This test report cannot be reproduced, except in full, without prior written permission of the Company. 除非另有說明，此報告結果僅對測試之樣品負責，同時此樣品僅保留 90 天。本報告未經本公司書面許可，不可部份複製。 This document is issued by the Company subject to its General Conditions of Service (www.sgs.com/terms_and_conditions.htm) and Terms and Conditions for Electronic Documents (www.sgs.com/terms_e-document.htm). Attention is drawn to the limitations of liability, indemnification and jurisdictional issues established therein. Even if printed this electronic document is to be treated as an original within the meaning of UCP 600 article 20b. The authenticity of this document may be verified at www.sgsonsite.com/authentication. Any holder of this document is advised that information contained hereon reflects the Company's findings at the time of its intervention only and within the limits of client's instructions, if any. The Company's sole responsibility is to its Client and this document does not exonerate parties to a transaction from exercising all their rights and obligations under the transaction documents.

1. GENERAL INFORMATION

1.1 Product Description

General:

Product Name	CDMA TS006		
Brand Name	Fujitsu Toshiba Mobile Communications Limited		
Model Name	TS006		
Power Supply	3.7Vdc Li-Ion battery		
	Battery:	Model No.:TSY01UAA, Supplier: au by KDDI	

CDMA:

DUT Standards And Power:	CDMA2000	Frequency Range		Maximum Rated EIRP Power 25 dBm
	Cellular	TX:	824.70-848.31 MHz	
RX:		869.70-893.31 MHz		
Type of Emission	CDMA2000 Cellular: 1M27F9W			
Hardware Version	Ver.2.0.0			
Software Version	V65.19.01			

Final Amplifier Voltage and Current Information:

Test Mode	DC voltage (V)	DC current (mA)
CDMA2000 Cellular	3.7Vdc	230

Bluetooth:

Bluetooth Version:	V2.1 + EDR (GFSK + $\pi/4$ DQPSK + 8DPSK)
Channel number:	79 channels
Modulation type:	Frequency Hopping Spread Spectrum
Transmit Power:	8.23 dBm (Peak)
Frequency Range:	2.402GHz – 2.480GHz
Dwell Time:	$\leq 0.4s$
Operating Mode:	Point-to-Point
Antenna Designation:	1/4 lambda monopole Antenna: -0.39dBi.

The EUT is compliance with Bluetooth 2.1 + EDR Standard.

This test report applies for CDMA2000 Cellular band.

1.2 Related Submittal(s) / Grant (s)

This submittal(s) (test report) is intended for **FCC ID: YUW-TS006** filing to comply with Section Part 22 subpart H of the FCC CFR 47 Rules.

1.3 Test Methodology

Both conducted and radiated testing were performed according to the procedures of FCC 47 CFR 2.1046, 2.1047, 2.1049, 2.1051, 2.1053, 2.1055, 2.1057.

1.4 Test Facility

The measurement facilities used to collect the 3m Radiated Emission and AC power line conducted data are located on the address of SGS Taiwan Ltd. Electronics & Communication Laboratory No. 134, Wu Kung Rd., Wuku Industrial Zone, Taipei Country, Taiwan which are constructed and calibrated to meet the FCC requirements in documents ANSI C63.4: 2003. FCC Registration Number are: 990257 and 236194, Canada Registration Number: 4620A-4

The 10 m Open Area Test Sites located on the address of SGS Taiwan Ltd. Electronics & Communication Laboratory No. 29, Pau-Tou-Tsuo Valley Chia-Pau Tsuen, Linkou Hsiang, Taipei county, which is constructed and calibrated to meet the CISPR 22/EN 55022 requirements. SGS Site No. 1(3 &10 meters) and FCC Registration Number: 94644.

1.5 Special Accessories

Not available for this EUT intended for grant.

1.6 Equipment Modifications

Not available for this EUT intended for grant.

2. SYSTEM TEST CONFIGURATION

2.1 EUT Configuration

The EUT configuration for testing is installed on RF field strength measurement to meet the Commissions requirement and operating in a manner which intends to maximize its emission characteristics in a continuous normal application.

2.2 EUT Exercise

The Toshiba CDMA cellular phone FCC ID: **YUW-TS006** was Tested With AC Adapter. The EUT was stayed in normal operation mode with CMU200. The EUT (Transmitter) was operated in the engineering mode to fix the Tx frequency which was for the purpose of the measurements.

2.3 Test Procedure

2.3.1 Conducted Measurement at Antenna Port:

According to measurement procured TIA/EIA 603C, the EUT is placed on a turn table which is 0.8 m above ground plane. A low loss of RF cable was used to connect the antenna port of EUT to measurement equipment.

2.3.2 Radiated Emissions (ERP/EIRP):

According to measurement procured TIA/EIA 603C. The EUT is placed on a turn table which is 0.8 m above ground plane. The turn table shall rotate 360 degrees to determine the position of maximum emission level. EUT is set 3m away from the receiving antenna which varied from 1m to 4m to find out the highest emission. And also, each emission was to be maximized by changing the polarization of receiving antenna both horizontal and vertical. In order to find out the max. Emission, the relative positions of this hand-held transmitter (EUT) was rotated through three orthogonal axes according to the requirements.

A standard antenna was used to replace the EUT and connect to the SG. Adjust the SG output level to reach the max emission level which was measured above.

2.4 Measurement Equipment Used:

Conducted Emission Test Site					
EQUIPMENT TYPE	MFR	MODEL NUMBER	SERIAL NUMBER	LAST CAL.	CAL DUE.
Spectrum Analyzer	Agilent	E4446A	MY43360126	04/19/2010	04/18/2012
Spectrum Analyzer	Agilent	E4440A	US41160416	01/25/2010	01/24/2011
Radio Communication Analyzer	R&S	CMU200	111787	10/31/2008	10/30/2012
800 – 1000MHz Filter	Micro-Tronics	BRM13462	001	01/05/2010	01/04/2011
1800 – 2000MHz Filter	Micro-Tronics	BRM13463	001	01/05/2010	01/04/2011
Temperature Chamber	TERCHY	MHG-120LF	911009	04/30/2010	04/29/2012
Temperature Chamber	GIANT FORCE	GTH-150-40-CP-AR	MAA0512-018	02/24/2010	02/23/2012
DC Block	Agilent	BLK-18	155452	07/05/2010	07/04/2011
Attenuator	Mini-Circuit	BW-S20W5	N/A	07/05/2010	07/04/2011
Attenuator	Mini-Circuit	BW-S10W5	N/A	07/05/2010	07/04/2011
Attenuator	Mini-Circuit	BW-S6W5	N/A	07/05/2010	07/04/2011
Splitter	Agilent	11636B	N/A	07/05/2010	07/04/2011
DC Power Supply	Chroma	41901	777188	04/15/2010	04/14/2012

Unless otherwise stated the results shown in this test report refer only to the sample(s) tested and such sample(s) are retained for 90 days only. This test report cannot be reproduced, except in full, without prior written permission of the Company. 除非另有說明，此報告結果僅對測試之樣品負責，同時此樣品僅保留 90 天。本報告未經本公司書面許可，不可部份複製。 This document is issued by the Company subject to its General Conditions of Service (www.sgs.com/terms_and_conditions.htm) and Terms and Conditions for Electronic Documents (www.sgs.com/terms_e-document.htm). Attention is drawn to the limitations of liability, indemnification and jurisdictional issues established therein. Even if printed this electronic document is to be treated as an original within the meaning of UCP 600 article 20b. The authenticity of this document may be verified at www.sgsonsite.com/authentication. Any holder of this document is advised that information contained hereon reflects the Company's findings at the time of its intervention only and within the limits of client's instructions, if any. The Company's sole responsibility is to its Client and this document does not exonerate parties to a transaction from exercising all their rights and obligations under the transaction documents.

ERP, EIRP MEASUREMENT EQUIPMENT List 966 Chamber

EQUIPMENT TYPE	MFR	MODEL NUMBER	SERIAL NUMBER	LAST CAL.	CAL DUE.
Spectrum Analyzer	R&S	FSP 40	100034	02/12/2010	02/11/2011
Bilog Antenna	SCHWAZBECK	VULB9160	3136	11/19/2009	11/18/2010
Dipole Antenna	SCHWAZBECK	VHAP	908/909	07/17/2010	07/16/2012
Dipole Antenna	SCHWAZBECK	UHAP	891/892	07/17/2010	07/16/2012
Horn antenna	SCHWAZBECK	BBHA 9120D	309/320	03/09/2009	03/08/2011
Signal Generator	R&S	SMR40	100210	02/10/2010	02/09/2012
Signal Generator	Agilent	E4438C	MY45093613	07/08/2010	07/07/2011
Pre-Amplifier	Agilent	8447D	1937A02834	11/28/2009	11/27/2010
Pre-Amplifier	Agilent	8449B	3008A01973	01/05/2010	01/04/2011
Attenuator	Mini-Circuit	BW-S20W5	001	07/05/2010	07/04/2011
Attenuator	Mini-Circuit	BW-S10W5	001	07/05/2010	07/04/2011
Attenuator	Mini-Circuit	BW-S6W5	001	07/05/2010	07/04/2011
Radio Communication Analyzer	R&S	CMU200	111787	10/31/2010	10/30/2012
Turn Table	HD	DT420	N/A	N.C.R	N.C.R
Antenna Tower	HD	MA240-N	240/657	N.C.R	N.C.R
Controller	HD	HD100	N/A	N.C.R	N.C.R
Low Loss Cable	HUBER+SUHNER	SUCOFLEX 104PEA-10M	10m	01/05/2010	01/04/2011
Low Loss Cable	HUBER+SUHNER	SUCOFLEX 104PEA-3M	3m	01/05/2010	01/04/2011
Filter 800-1000	Micro-Tronics	BRM13462	1	01/05/2010	01/04/2011
Filter 1800-2000	Micro-Tronics	BRM13463	1	01/05/2010	01/04/2011
3m Site	SGS	966 chamber	N/A	11/09/2010	11/08/2011

Unless otherwise stated the results shown in this test report refer only to the sample(s) tested and such sample(s) are retained for 90 days only. This test report cannot be reproduced, except in full, without prior written permission of the Company. 除非另有說明，此報告結果僅對測試之樣品負責，同時此樣品僅保留 90 天。本報告未經本公司書面許可，不可部份複製。 This document is issued by the Company subject to its General Conditions of Service (www.sgs.com/terms_and_conditions.htm) and Terms and Conditions for Electronic Documents (www.sgs.com/terms_e-document.htm). Attention is drawn to the limitations of liability, indemnification and jurisdictional issues established therein. Even if printed this electronic document is to be treated as an original within the meaning of UCP 600 article 20b. The authenticity of this document may be verified at www.sgsonsite.com/authentication. Any holder of this document is advised that information contained hereon reflects the Company's findings at the time of its intervention only and within the limits of client's instructions, if any. The Company's sole responsibility is to its Client and this document does not exonerate parties to a transaction from exercising all their rights and obligations under the transaction documents.

2.5 Configuration of Tested System

Fig. 1-1 Configuration for Radiated Emission

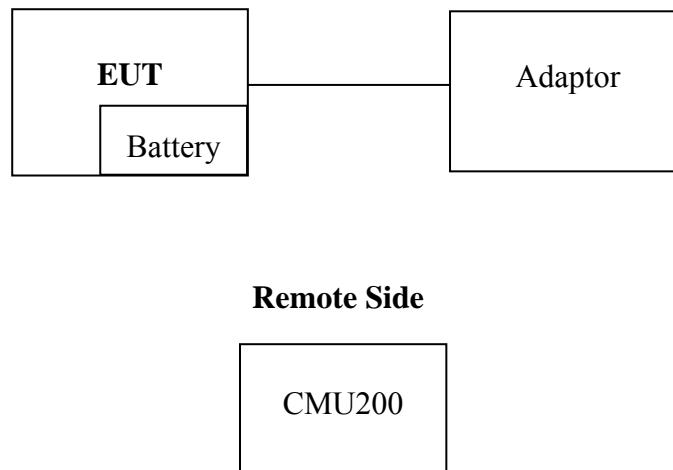

Table 2-1 Equipment Used in Tested System

Item	Equipment	Mfr/Brand	Model/ Type No.	Series No.	Data Cable	Power Cord
1.	Universal Radio Communication Tester	R&S	CMU200	102189	N/A	Un-shielded
2.	Adaptor	AU by KDDI	MT-WEA	N/A	N/A	Un-shielded

Unless otherwise stated the results shown in this test report refer only to the sample(s) tested and such sample(s) are retained for 90 days only. This test report cannot be reproduced, except in full, without prior written permission of the Company. 除非另有說明，此報告結果僅對測試之樣品負責，同時此樣品僅保留 90 天。本報告未經本公司書面許可，不可部份複製。 This document is issued by the Company subject to its General Conditions of Service (www.sgs.com/terms_and_conditions.htm) and Terms and Conditions for Electronic Documents (www.sgs.com/terms_e-document.htm). Attention is drawn to the limitations of liability, indemnification and jurisdictional issues established therein. Even if printed this electronic document is to be treated as an original within the meaning of UCP 600 article 20b. The authenticity of this document may be verified at www.sgsonsite.com/authentication. Any holder of this document is advised that information contained hereon reflects the Company's findings at the time of its intervention only and within the limits of client's instructions, if any. The Company's sole responsibility is to its Client and this document does not exonerate parties to a transaction from exercising all their rights and obligations under the transaction documents.

3. SUMMARY OF TEST RESULTS

FCC Rules	Description Of Test	Result
§2.1046(a) §22.913(a)	RF Power Output	Compliant
§2.1046(a) §22.913(a)	ERP/ EIRP measurement	Compliant
§2.1049(h)	99% Occupied Bandwidth	Compliant
§2.1051 §22.917(a)	Out of Band Emissions at Antenna Terminals and Band Edge	Compliant
§2.1053 §22.917(a)	Field Strength of Spurious Radiation	Compliant
§2.1055(a)(1) §22.355	Frequency Stability vs. Temperature	Compliant
§2.1055(d)(2) §22.355	Frequency Stability vs. Voltage	Compliant

4. DESCRIPTION OF TEST MODES

The EUT has been tested under operating condition.

Set EUT power control “all up bits” for all test mode through base station.

The Channel Low, Mid and High for each type of bands with rated data rate were chosen for full testing.

The field strength of spurious radiation emission was measured as EUT stand-up position (H mode) and lie down position (E1, E2 mode) for CDMA2000 Cellular band with power adaptor. The worst-case H mode of CDMA2000 Cellular band for channels Low, Mid and High were reported.

Max ERP/EIRP measurement result:

	dBm		W
CDMA2000 Cellular Band	25.00	ERP	0.316

5. RF POWER OUTPUT MEASUREMENT

5.1 Standard Applicable

According to FCC §2.1046.

FCC 22.913(a) Mobile station is limited to 7W.

5.2 Test Set-up:

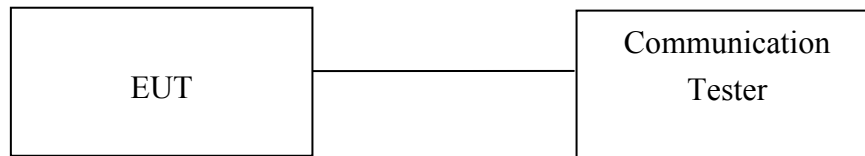

Note: Measurement setup for testing on Antenna connector

5.3 Measurement Procedure

The transmitter output was connected to a calibrated Communication Tester by a low loss RF cable. The power output at the transmitter antenna port was determined by adding the value of the attenuator to the reading from tester.

5.4 Measurement Equipment Used:

Conducted Emission Test Site					
EQUIPMENT TYPE	MFR	MODEL NUMBER	SERIAL NUMBER	LAST CAL.	CAL DUE.
Radio Communication Analyzer	R&S	CMU200	111787	10/31/2010	10/30/2012
Low Loss Cable	HUBER+SUHNER	SUCOFLEX 104PEA-3M	3m	01/05/2010	01/04/2011

Unless otherwise stated the results shown in this test report refer only to the sample(s) tested and such sample(s) are retained for 90 days only. This test report cannot be reproduced, except in full, without prior written permission of the Company. 除非另有說明，此報告結果僅對測試之樣品負責，同時此樣品僅保留 90 天。本報告未經本公司書面許可，不可部份複製。 This document is issued by the Company subject to its General Conditions of Service (www.sgs.com/terms_and_conditions.htm) and Terms and Conditions for Electronic Documents (www.sgs.com/terms_e-document.htm). Attention is drawn to the limitations of liability, indemnification and jurisdictional issues established therein. Even if printed this electronic document is to be treated as an original within the meaning of UCP 600 article 20b. The authenticity of this document may be verified at www.sgsonsite.com/authentication. Any holder of this document is advised that information contained hereon reflects the Company's findings at the time of its intervention only and within the limits of client's instructions, if any. The Company's sole responsibility is to its Client and this document does not exonerate parties to a transaction from exercising all their rights and obligations under the transaction documents.

5.5 Measurement Result

EUT Mode	Frequency (MHz)	CH	Peak Power (dBm)	Avg. Power (dBm)
CDMA 2000 Cellular	824.70	1013	24.99	23.98
	836.52	384	24.84	23.81
	848.31	777	24.83	23.88

Unless otherwise stated the results shown in this test report refer only to the sample(s) tested and such sample(s) are retained for 90 days only. This test report cannot be reproduced, except in full, without prior written permission of the Company. 除非另有說明，此報告結果僅對測試之樣品負責，同時此樣品僅保留 90 天。本報告未經本公司書面許可，不可部份複製。 This document is issued by the Company subject to its General Conditions of Service (www.sgs.com/terms_and_conditions.htm) and Terms and Conditions for Electronic Documents (www.sgs.com/terms_e-document.htm). Attention is drawn to the limitations of liability, indemnification and jurisdictional issues established therein. Even if printed this electronic document is to be treated as an original within the meaning of UCP 600 article 20b. The authenticity of this document may be verified at www.sgsonsite.com/authentication. Any holder of this document is advised that information contained hereon reflects the Company's findings at the time of its intervention only and within the limits of client's instructions, if any. The Company's sole responsibility is to its Client and this document does not exonerate parties to a transaction from exercising all their rights and obligations under the transaction documents.

6. ERP/EIRP MEASUREMENT

6.1 Standard Applicable

According to FCC §2.1046

FCC 22.913(a) Mobile station are limited to 7W ERP.

6.2 Test SET-UP (Block Diagram of Configuration)

(A) Radiated Emission Test Set-Up, Frequency Below 1000MHz

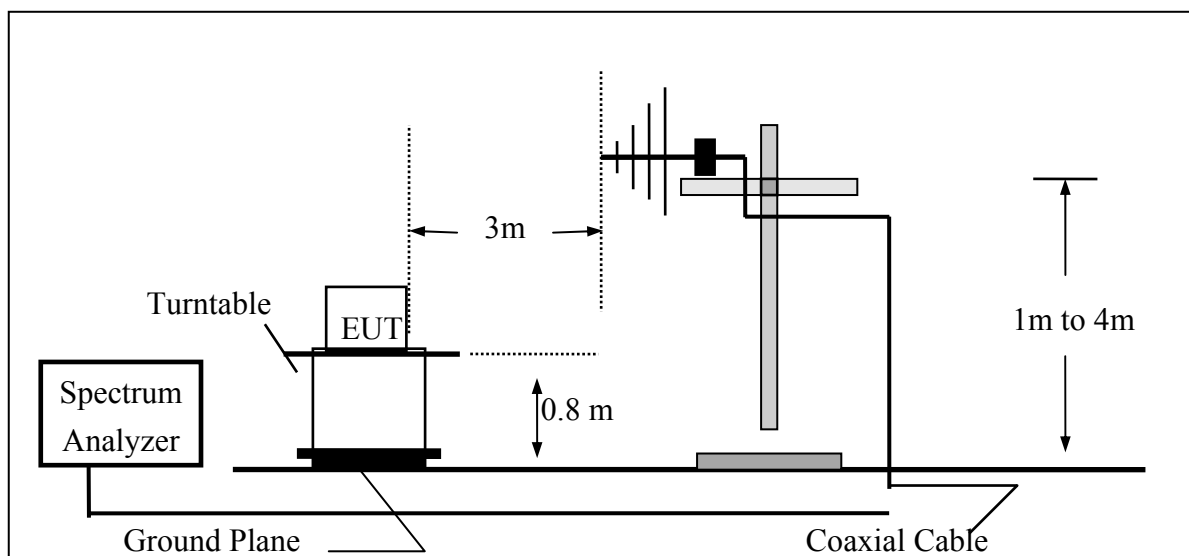

Unless otherwise stated the results shown in this test report refer only to the sample(s) tested and such sample(s) are retained for 90 days only. This test report cannot be reproduced, except in full, without prior written permission of the Company. 除非另有說明，此報告結果僅對測試之樣品負責，同時此樣品僅保留 90 天。本報告未經本公司書面許可，不可部份複製。 This document is issued by the Company subject to its General Conditions of Service (www.sgs.com/terms_and_conditions.htm) and Terms and Conditions for Electronic Documents (www.sgs.com/terms_e-document.htm). Attention is drawn to the limitations of liability, indemnification and jurisdictional issues established therein. Even if printed this electronic document is to be treated as an original within the meaning of UCP 600 article 20b. The authenticity of this document may be verified at www.sgsonsite.com/authentication. Any holder of this document is advised that information contained hereon reflects the Company's findings at the time of its intervention only and within the limits of client's instructions, if any. The Company's sole responsibility is to its Client and this document does not exonerate parties to a transaction from exercising all their rights and obligations under the transaction documents.

(B) Radiated Emission Test Set-UP Frequency Over 1 GHz

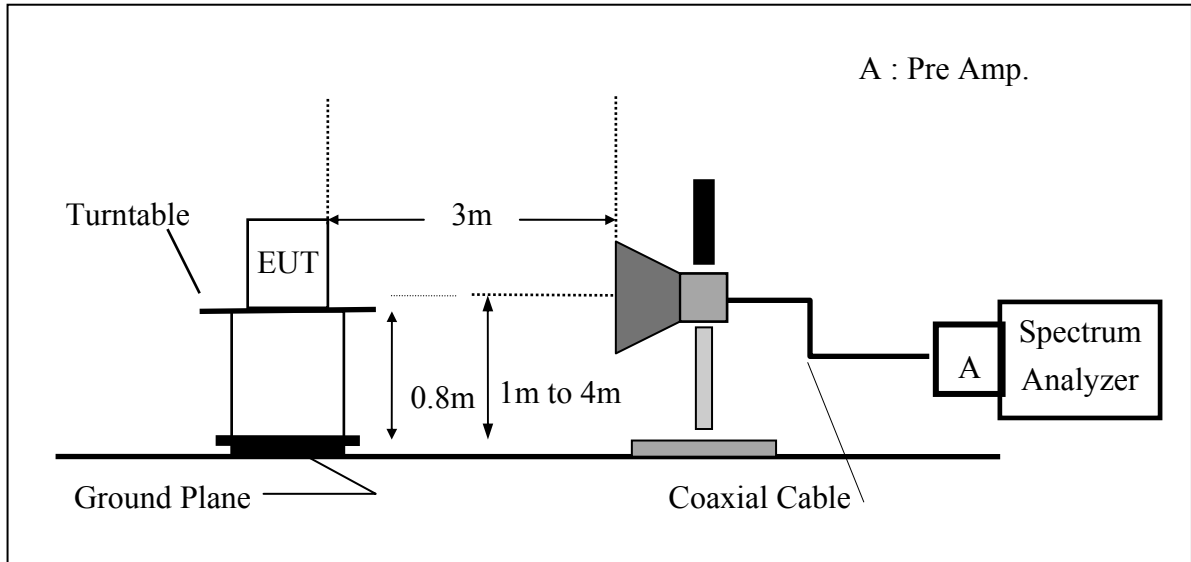

(C) Substituted Method Test Set-UP

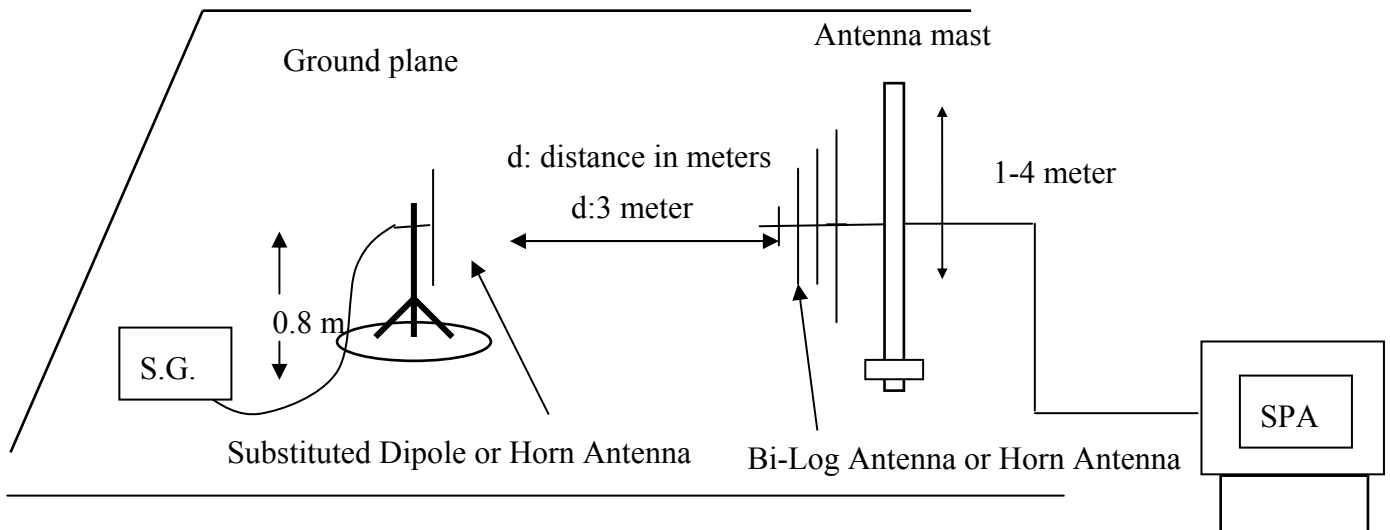

Unless otherwise stated the results shown in this test report refer only to the sample(s) tested and such sample(s) are retained for 90 days only. This test report cannot be reproduced, except in full, without prior written permission of the Company. 除非另有說明，此報告結果僅對測試之樣品負責，同時此樣品僅保留 90 天。本報告未經本公司書面許可，不可部份複製。 This document is issued by the Company subject to its General Conditions of Service (www.sgs.com/terms_and_conditions.htm) and Terms and Conditions for Electronic Documents (www.sgs.com/terms_e-document.htm). Attention is drawn to the limitations of liability, indemnification and jurisdictional issues established therein. Even if printed this electronic document is to be treated as an original within the meaning of UCP 600 article 20b. The authenticity of this document may be verified at www.sgsonsite.com/authentication. Any holder of this document is advised that information contained hereon reflects the Company's findings at the time of its intervention only and within the limits of client's instructions, if any. The Company's sole responsibility is to its Client and this document does not exonerate parties to a transaction from exercising all their rights and obligations under the transaction documents.

6.3 Measurement Procedure

The EUT was placed on a non-conductive turntable using a non-conductive support. The radiated emission at the fundamental frequency was measured at 3 m with a test antenna and EMI spectrum analyzer.

During the measurement, the EUT was in communication with the station. The highest emission was recorded with the rotation of the turntable and the lowering of the test antenna from 4m to 1m. The reading was recorded and the field strength (E in dBuV/m) was calculated.

ERP in frequency band 824.2 – 848.80MHz were measured using a substitution method. The EUT was replaced by a dipole antenna connected, the S.G. output was recorded and ERP was calculated as follows:

$$\text{ERP} = \text{S.G. output (dBm)} + \text{Antenna Gain (dBd)} - \text{Cable Loss (dB)}$$

6.4 Measurement Equipment Used:

Refer to section 2.4 in this report

6.5 Measurement Result

EUT Mode	Frequency (MHz)	CH	EUT Pol.	Antenna Pol.	SPA Reading (dBuV)	S.G. Output (dBm)	Antenna Gain (dBd)	Cable Loss (dB)	ERP (dBm)	Limit (dBm)
CDMA2000 Cellular	824.70	1013	H	V	121.40	35.04	-7.88	3.63	23.53	38.45
				H	115.30	29.04	-7.88	3.63	17.54	38.45
			E1	V	107.20	20.84	-7.88	3.63	9.33	38.45
				H	112.40	26.14	-7.88	3.63	14.64	38.45
			E2	V	107.80	21.44	-7.88	3.63	9.93	38.45
				H	122.30	36.04	-7.88	3.63	24.54	38.45
	836.52	384	H	V	119.60	33.34	-7.88	3.65	21.81	38.45
				H	111.40	25.17	-7.88	3.65	13.64	38.45
			E1	V	105.10	18.84	-7.88	3.65	7.31	38.45
				H	120.00	33.77	-7.88	3.65	22.24	38.45
			E2	V	105.50	19.24	-7.88	3.65	7.71	38.45
				H	119.90	33.67	-7.88	3.65	22.14	38.45
	848.31	777	H	V	122.70	36.55	-7.88	3.67	25.00	38.45
				H	113.30	27.10	-7.88	3.67	15.55	38.45
			E1	V	106.60	20.44	-7.88	3.67	8.89	38.45
				H	122.70	36.50	-7.88	3.67	24.95	38.45
			E2	V	106.20	20.05	-7.88	3.67	8.50	38.45
				H	122.20	36.00	-7.88	3.67	24.45	38.45

Remark :

- (1) The RBW,VBW of SPA for frequency
RBW=3MHz, VBW=3MHz

Unless otherwise stated the results shown in this test report refer only to the sample(s) tested and such sample(s) are retained for 90 days only. This test report cannot be reproduced, except in full, without prior written permission of the Company. 除非另有說明，此報告結果僅對測試之樣品負責，同時此樣品僅保留 90 天。本報告未經本公司書面許可，不可部份複製。 This document is issued by the Company subject to its General Conditions of Service (www.sgs.com/terms_and_conditions.htm) and Terms and Conditions for Electronic Documents (www.sgs.com/terms_e-document.htm). Attention is drawn to the limitations of liability, indemnification and jurisdictional issues established therein. Even if printed this electronic document is to be treated as an original within the meaning of UCP 600 article 20b. The authenticity of this document may be verified at www.sgsonsite.com/authentication. Any holder of this document is advised that information contained hereon reflects the Company's findings at the time of its intervention only and within the limits of client's instructions, if any. The Company's sole responsibility is to its Client and this document does not exonerate parties to a transaction from exercising all their rights and obligations under the transaction documents.

7. 99% OCCUPIED BANDWIDTH MEASUREMENT

7.1 Standard Applicable

According to §FCC 2.1049.

7.2 Test Set-up:

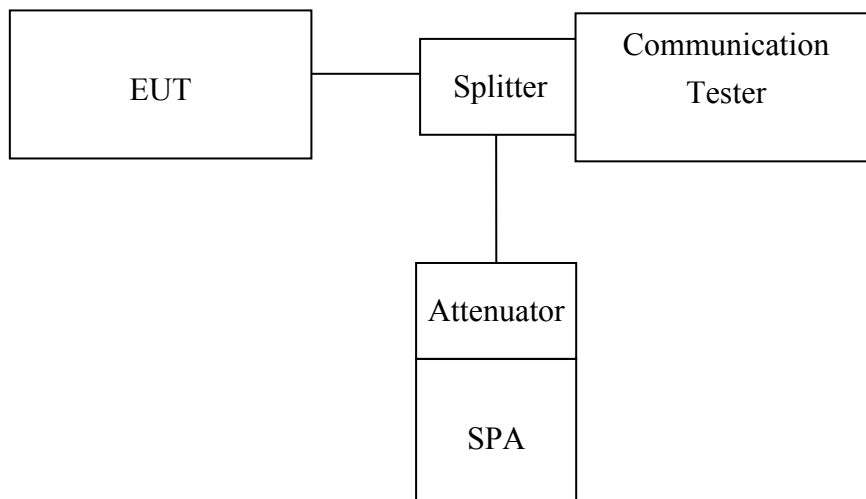

Note: Measurement setup for testing on Antenna connector

7.3 Measurement Procedure

The EUT's output RF connector was connected with a short cable to the spectrum analyzer, RBW (15KHz) was set to about 1% of emission BW, VBW= 3 times RBW(47KHz), -26dBc display line was placed on the screen (or 99% bandwidth), the occupied bandwidth is the delta frequency between the two points where the display line intersects the signal trace.

7.4 Measurement Equipment Used:

Refer to section 2.4 in this report

7.5 Measurement Result:

EUT Mode	Frequency (MHz)	CH	99% Bandwidth (MHz)
CDMA2000 Cellular	824.70	1013	1.2750
	836.52	384	1.2736
	848.31	777	1.2729

Unless otherwise stated the results shown in this test report refer only to the sample(s) tested and such sample(s) are retained for 90 days only. This test report cannot be reproduced, except in full, without prior written permission of the Company. 除非另有說明，此報告結果僅對測試之樣品負責，同時此樣品僅保留 90 天。本報告未經本公司書面許可，不可部份複製。 This document is issued by the Company subject to its General Conditions of Service (www.sgs.com/terms_and_conditions.htm) and Terms and Conditions for Electronic Documents (www.sgs.com/terms_e-document.htm). Attention is drawn to the limitations of liability, indemnification and jurisdictional issues established therein. Even if printed this electronic document is to be treated as an original within the meaning of UCP 600 article 20b. The authenticity of this document may be verified at www.sgsonsite.com/authentication. Any holder of this document is advised that information contained hereon reflects the Company's findings at the time of its intervention only and within the limits of client's instructions, if any. The Company's sole responsibility is to its Client and this document does not exonerate parties to a transaction from exercising all their rights and obligations under the transaction documents.

Figure 7-1: CDMA2000 Cellular Channel Low

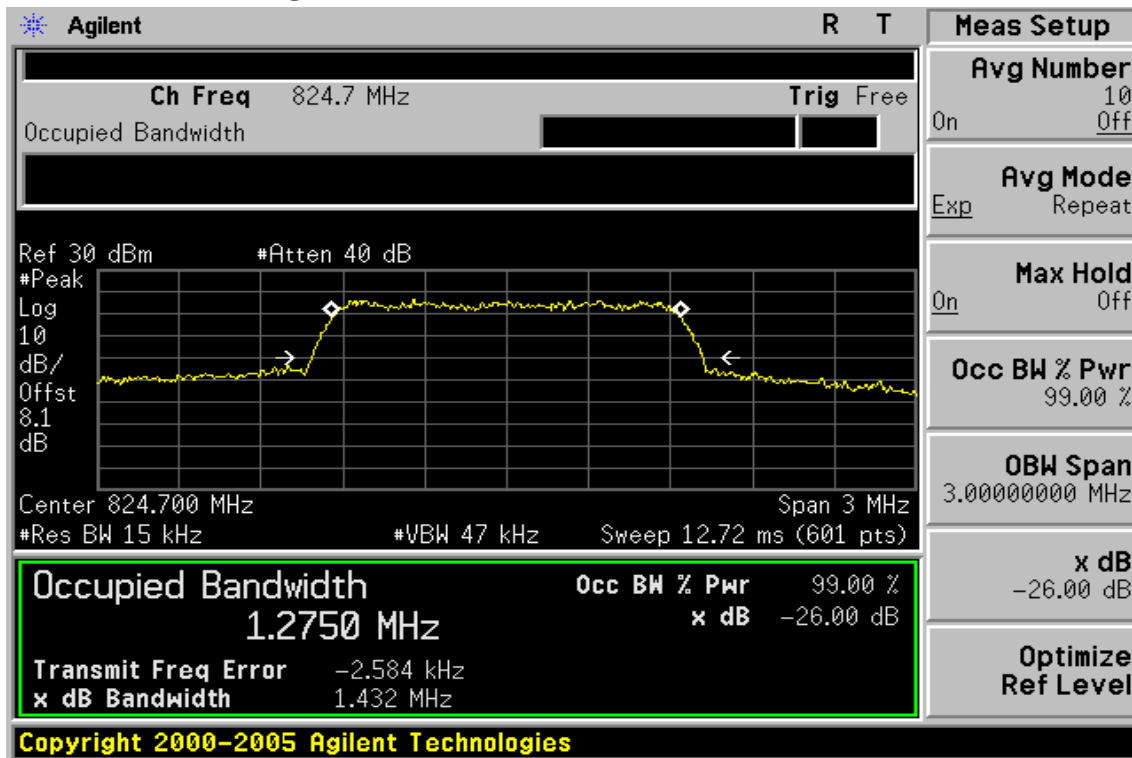
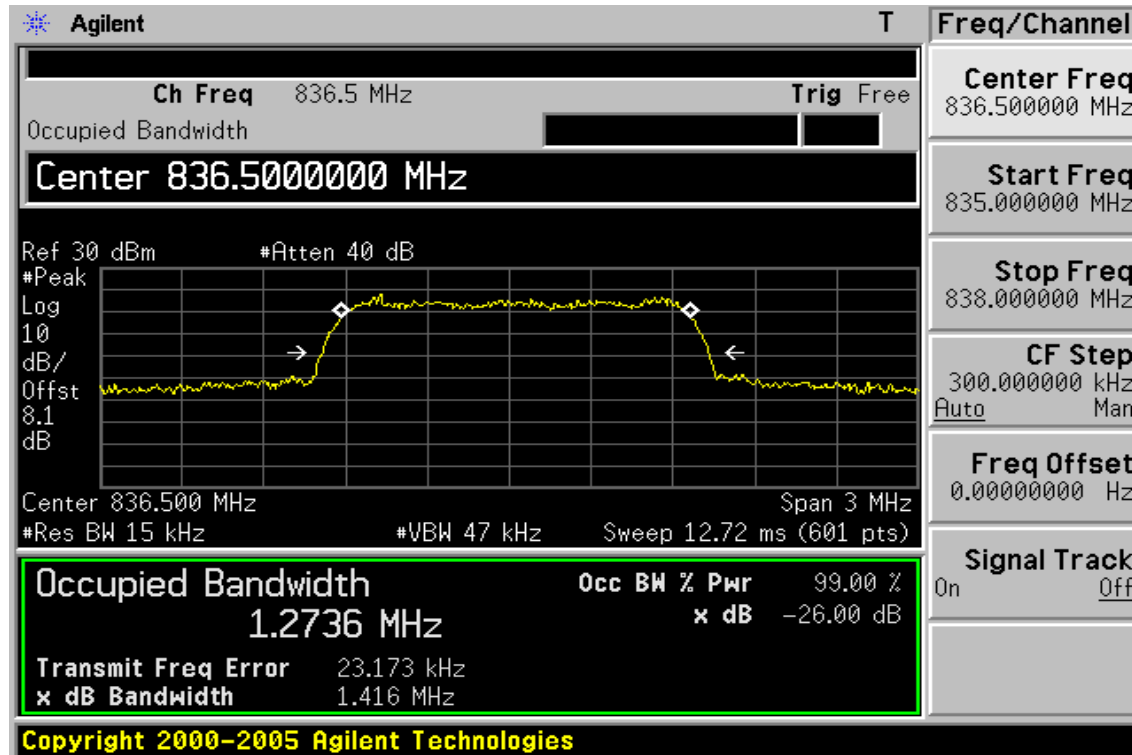
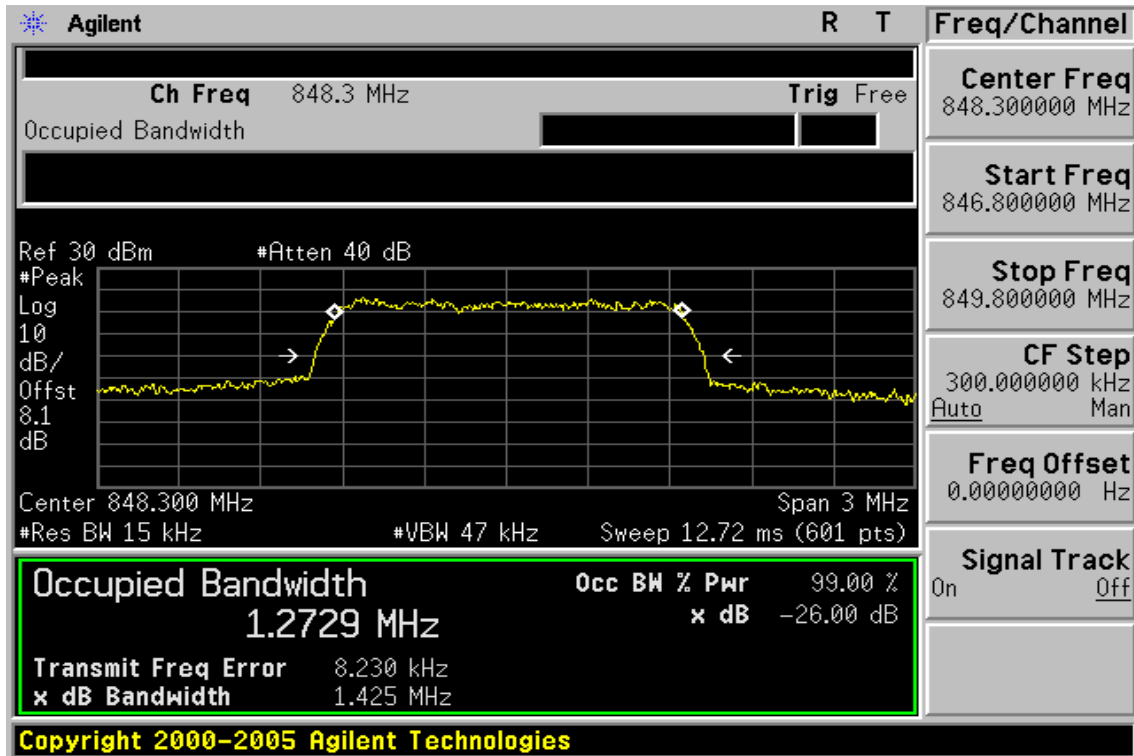

Figure 7-2 CDMA2000 Cellular Channel Mid



Unless otherwise stated the results shown in this test report refer only to the sample(s) tested and such sample(s) are retained for 90 days only. This test report cannot be reproduced, except in full, without prior written permission of the Company. 除非另有說明，此報告結果僅對測試之樣品負責，同時此樣品僅保留 90 天。本報告未經本公司書面許可，不可部份複製。 This document is issued by the Company subject to its General Conditions of Service (www.sgs.com/terms_and_conditions.htm) and Terms and Conditions for Electronic Documents (www.sgs.com/terms_e-document.htm). Attention is drawn to the limitations of liability, indemnification and jurisdictional issues established therein. Even if printed this electronic document is to be treated as an original within the meaning of UCP 600 article 20b. The authenticity of this document may be verified at www.sgs.com/authentication. Any holder of this document is advised that information contained hereon reflects the Company's findings at the time of its intervention only and within the limits of client's instructions, if any. The Company's sole responsibility is to its Client and this document does not exonerate parties to a transaction from exercising all their rights and obligations under the transaction documents.

Figure 7-3: CDMA2000 Cellular Channel High



Unless otherwise stated the results shown in this test report refer only to the sample(s) tested and such sample(s) are retained for 90 days only. This test report cannot be reproduced, except in full, without prior written permission of the Company. 除非另有說明，此報告結果僅對測試之樣品負責，同時此樣品僅保留 90 天。本報告未經本公司書面許可，不可部份複製。 This document is issued by the Company subject to its General Conditions of Service (www.sgs.com/terms_and_conditions.htm) and Terms and Conditions for Electronic Documents (www.sgs.com/terms_e-document.htm). Attention is drawn to the limitations of liability, indemnification and jurisdictional issues established therein. Even if printed this electronic document is to be treated as an original within the meaning of UCP 600 article 20b. The authenticity of this document may be verified at www.sgsonsite.com/authentication. Any holder of this document is advised that information contained hereon reflects the Company's findings at the time of its intervention only and within the limits of client's instructions, if any. The Company's sole responsibility is to its Client and this document does not exonerate parties to a transaction from exercising all their rights and obligations under the transaction documents.

8. OUT OF BAND EMISSION AT ANTENNA TERMINALS

8.1 Standard Applicable

According to FCC §2.1051.

FCC §22.917(a) the magnitude of each spurious and harmonic emission that can be detected when the equipment is operated under the conditions specified in the instruction manual and/ or alignment procedure, shall not be less than $43 + 10 \log$ (mean output power in watts) dBc below the mean power output outside a license's frequency block (-13dBm)

8.2 Test SET-UP

Refer to section 7.2 in this report

8.3 Measurement Procedure

The RF output of the transceiver was connected to a spectrum analyzer through appropriate attenuation. The resolution bandwidth of the spectrum analyzer was set at 1MHz, sufficient scans were taken to show the out of band Emissions if any up to 10th harmonic.

For the out of band: Set the RBW, VBW = 1MHz, Start=30MHz, Stop= 10 th harmonic. Limit = -13dBm

Band Edge Requirements: In the 1 MHz bands immediately outside and adjacent to the frequency block, a resolution bandwidth of at least 1 percent of the emission bandwidth of the fundamental emission of the transmitter may be employed to measure the out of band Emissions. Limit, -13dBm.

8.4 Measurement Equipment Used:

Refer to section 2.4 in this report

8.5 Measurement Result

Refer to next page for plots.

Figure 8-1: Out of Band emission at antenna terminals–Cellular Band Lowest Channel

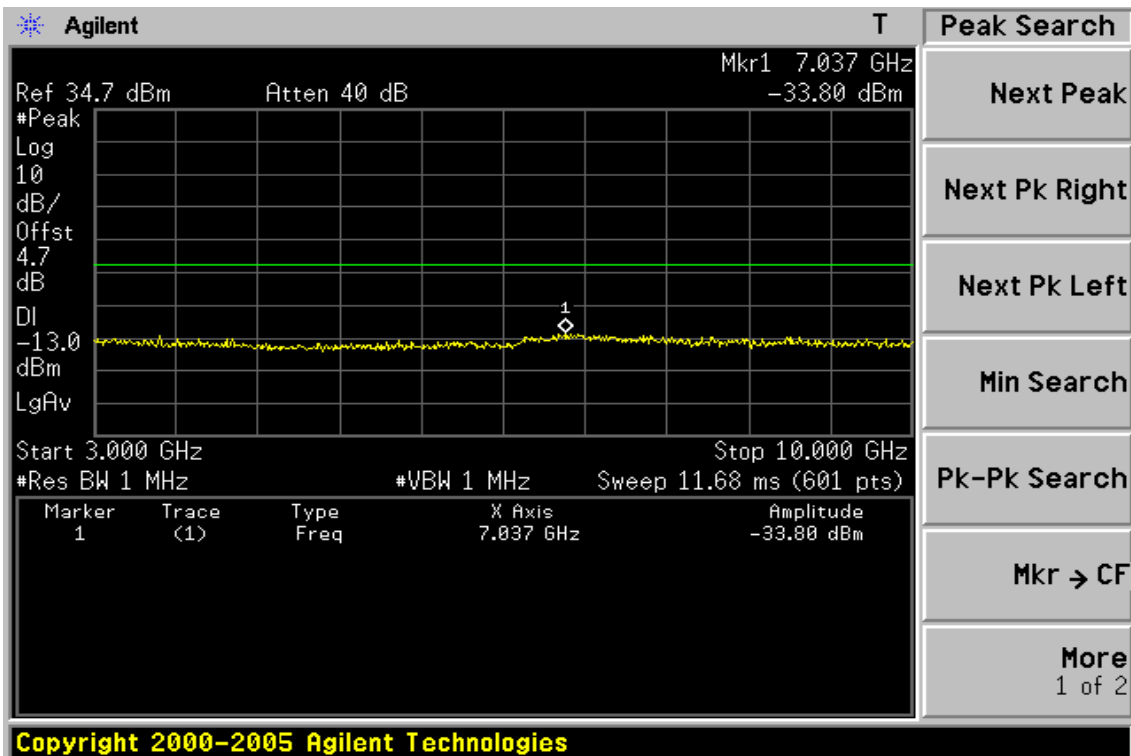
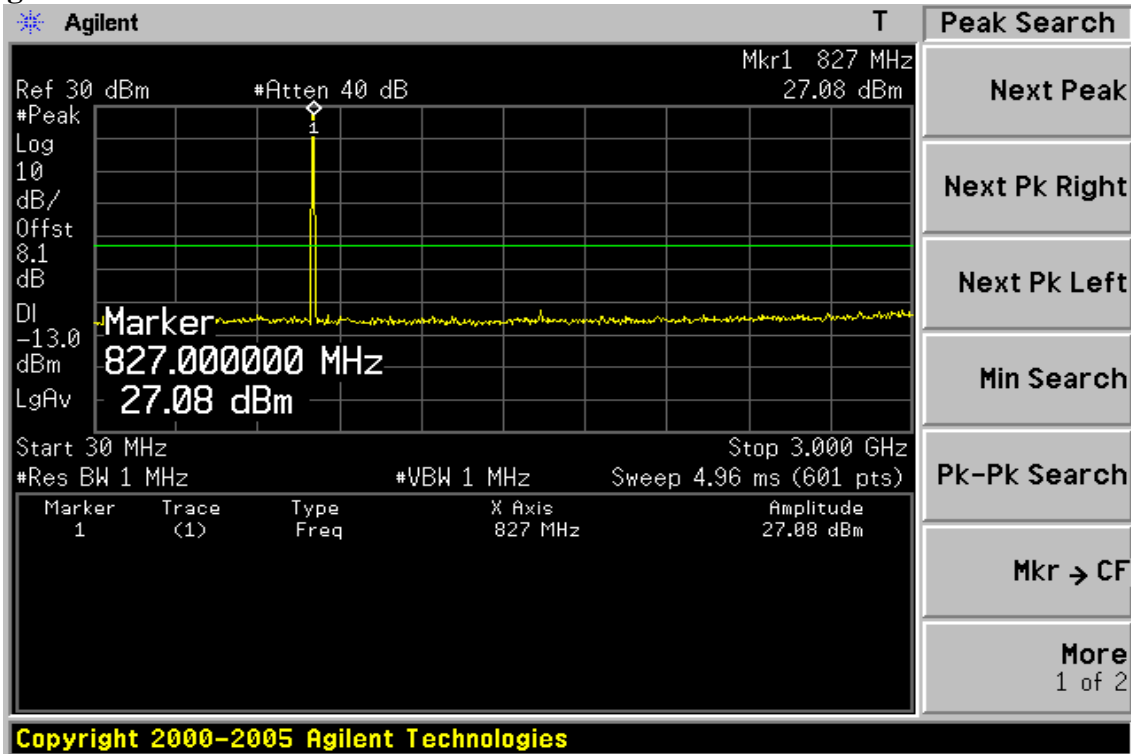

Unless otherwise stated the results shown in this test report refer only to the sample(s) tested and such sample(s) are retained for 90 days only. This test report cannot be reproduced, except in full, without prior written permission of the Company. 除非另有說明，此報告結果僅對測試之樣品負責，同時此樣品僅保留 90 天。本報告未經本公司書面許可，不可部份複製。 This document is issued by the Company subject to its General Conditions of Service (www.sgs.com/terms_and_conditions.htm) and Terms and Conditions for Electronic Documents (www.sgs.com/terms_e-document.htm). Attention is drawn to the limitations of liability, indemnification and jurisdictional issues established therein. Even if printed this electronic document is to be treated as an original within the meaning of UCP 600 article 20b. The authenticity of this document may be verified at www.sgs.com/authentication. Any holder of this document is advised that information contained hereon reflects the Company's findings at the time of its intervention only and within the limits of client's instructions, if any. The Company's sole responsibility is to its Client and this document does not exonerate parties to a transaction from exercising all their rights and obligations under the transaction documents.

Figure 8-2: Out of Band emission at antenna terminals –Cellular Band Mid Channel

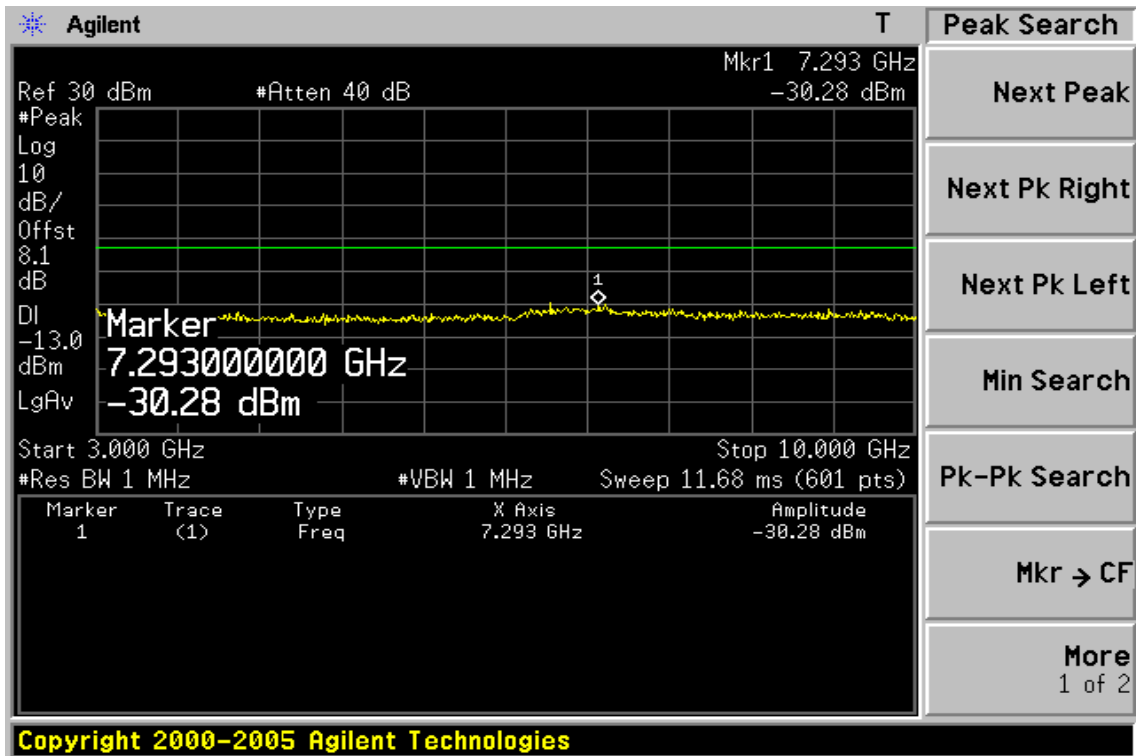
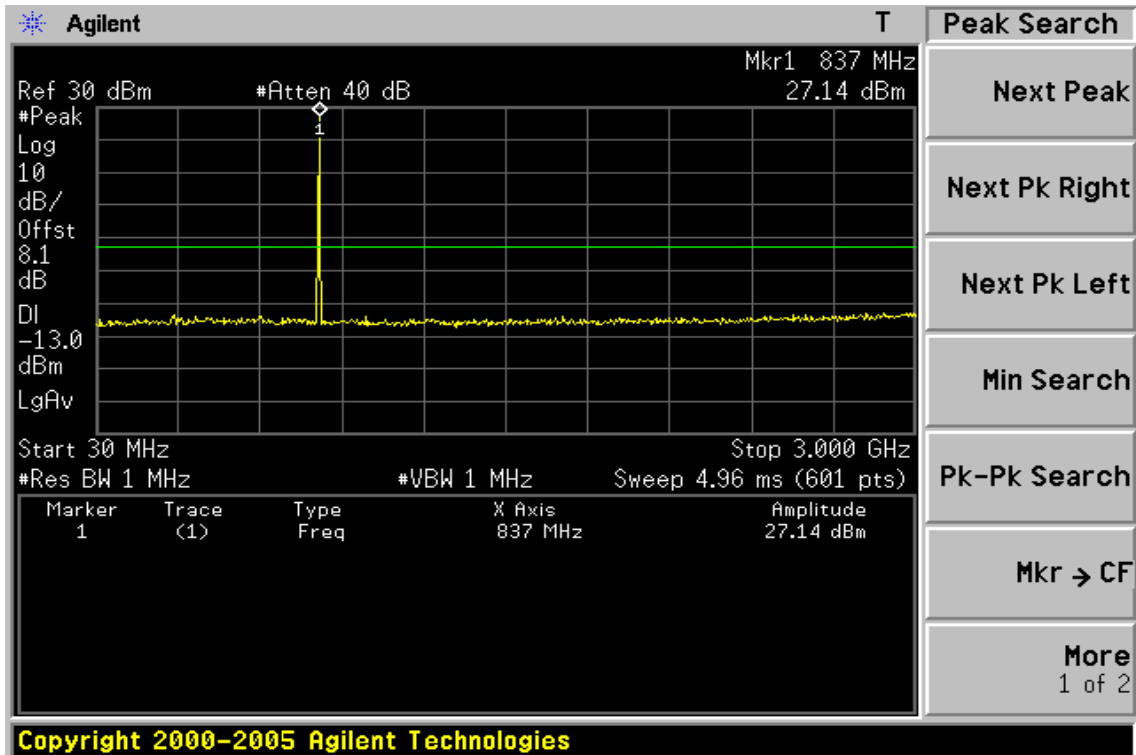

Unless otherwise stated the results shown in this test report refer only to the sample(s) tested and such sample(s) are retained for 90 days only. This test report cannot be reproduced, except in full, without prior written permission of the Company. 除非另有說明，此報告結果僅對測試之樣品負責，同時此樣品僅保留 90 天。本報告未經本公司書面許可，不可部份複製。 This document is issued by the Company subject to its General Conditions of Service (www.sgs.com/terms_and_conditions.htm) and Terms and Conditions for Electronic Documents (www.sgs.com/terms_e-document.htm). Attention is drawn to the limitations of liability, indemnification and jurisdictional issues established therein. Even if printed this electronic document is to be treated as an original within the meaning of UCP 600 article 20b. The authenticity of this document may be verified at www.sgs.com/authentication. Any holder of this document is advised that information contained hereon reflects the Company's findings at the time of its intervention only and within the limits of client's instructions, if any. The Company's sole responsibility is to its Client and this document does not exonerate parties to a transaction from exercising all their rights and obligations under the transaction documents.

Figure 8-3: Out of Band emission at antenna terminals–Cellular Band Highest Channel

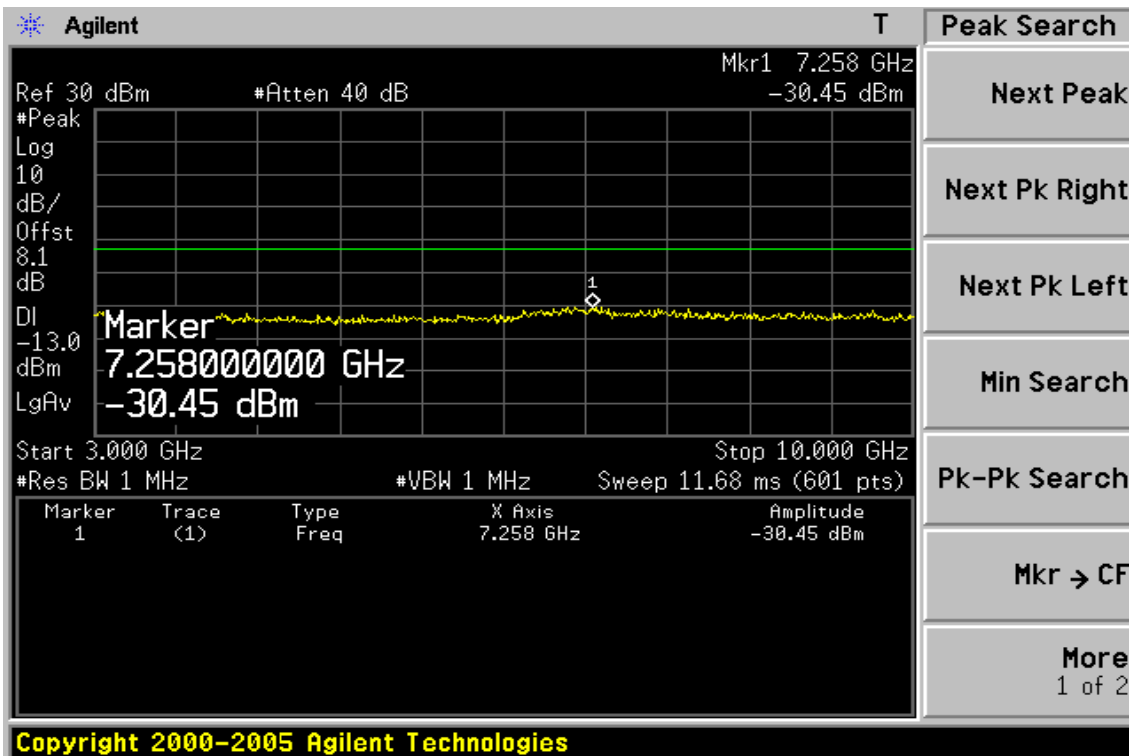
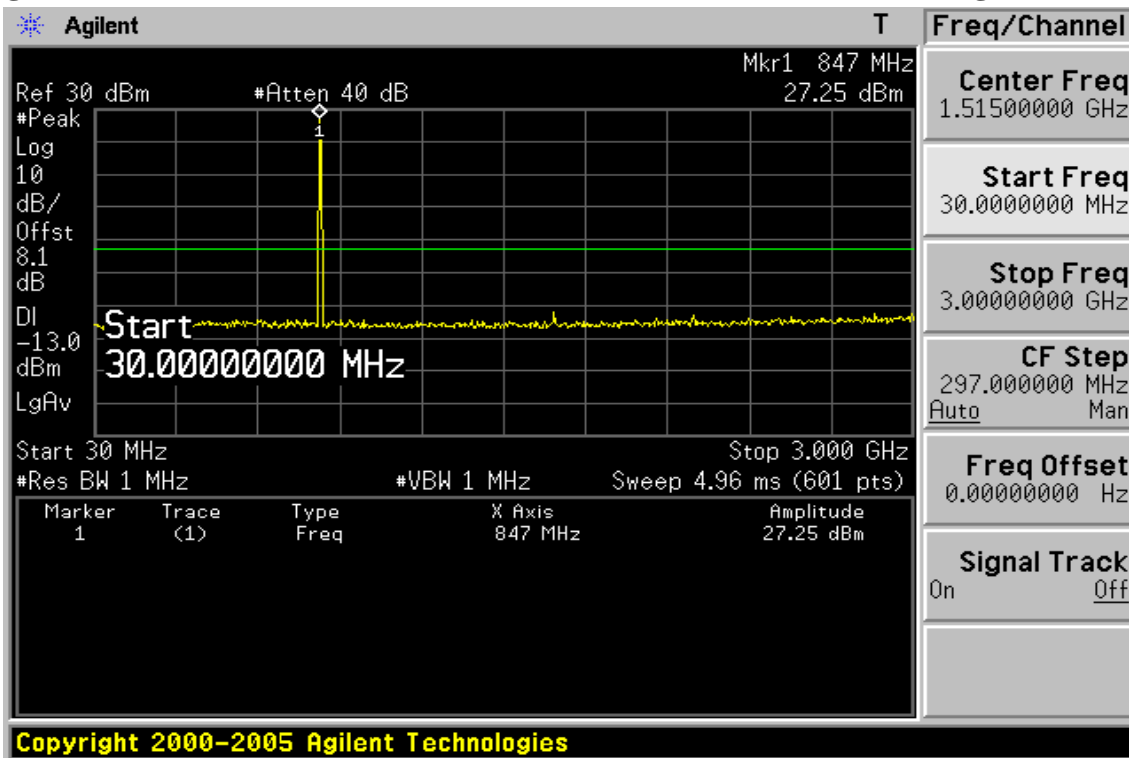

Unless otherwise stated the results shown in this test report refer only to the sample(s) tested and such sample(s) are retained for 90 days only. This test report cannot be reproduced, except in full, without prior written permission of the Company. 除非另有說明，此報告結果僅對測試之樣品負責，同時此樣品僅保留 90 天。本報告未經本公司書面許可，不可部份複製。 This document is issued by the Company subject to its General Conditions of Service (www.sgs.com/terms_and_conditions.htm) and Terms and Conditions for Electronic Documents (www.sgs.com/terms_e-document.htm). Attention is drawn to the limitations of liability, indemnification and jurisdictional issues established therein. Even if printed this electronic document is to be treated as an original within the meaning of UCP 600 article 20b. The authenticity of this document may be verified at www.sgs.com/authentication. Any holder of this document is advised that information contained hereon reflects the Company's findings at the time of its intervention only and within the limits of client's instructions, if any. The Company's sole responsibility is to its Client and this document does not exonerate parties to a transaction from exercising all their rights and obligations under the transaction documents.

Figure 8-4: Band edge emission at antenna terminals –Cellular Band Channel Lowest

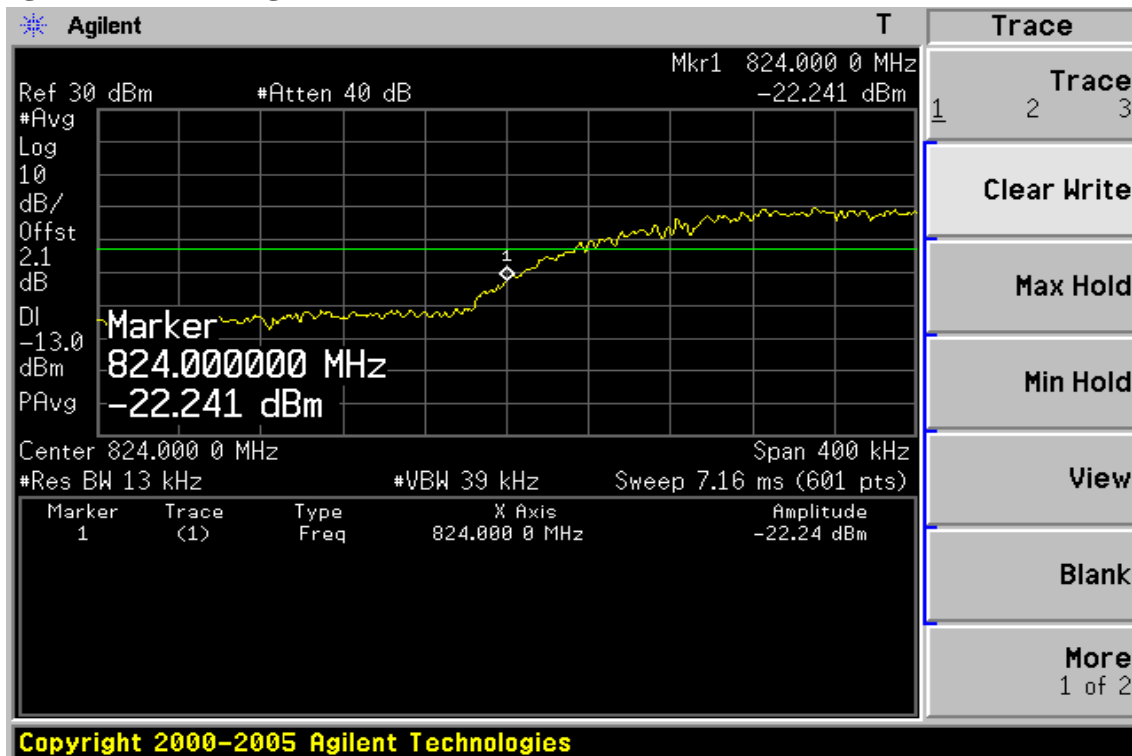
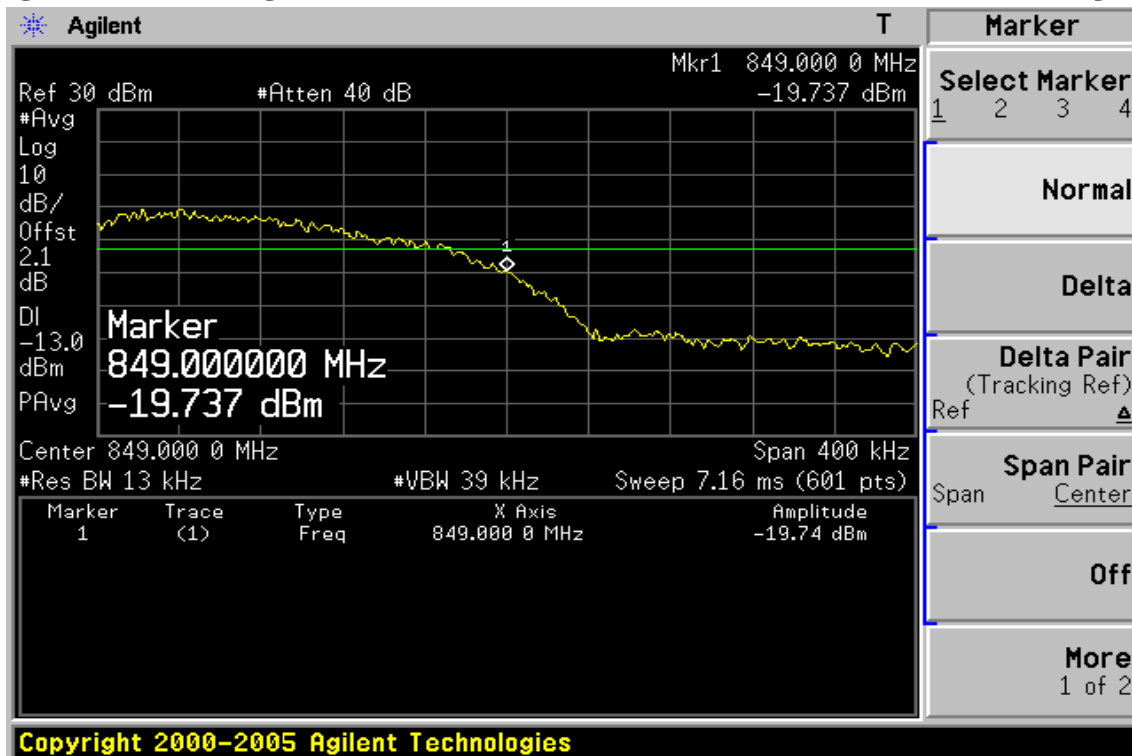

Figure 8-5: Band edge emission at antenna terminals –Cellular Band Channel Highest



Unless otherwise stated the results shown in this test report refer only to the sample(s) tested and such sample(s) are retained for 90 days only. This test report cannot be reproduced, except in full, without prior written permission of the Company. 除非另有說明，此報告結果僅對測試之樣品負責，同時此樣品僅保留 90 天。本報告未經本公司書面許可，不可部份複製。 This document is issued by the Company subject to its General Conditions of Service (www.sgs.com/terms_and_conditions.htm) and Terms and Conditions for Electronic Documents (www.sgs.com/terms_e-document.htm). Attention is drawn to the limitations of liability, indemnification and jurisdictional issues established therein. Even if printed this electronic document is to be treated as an original within the meaning of UCP 600 article 20b. The authenticity of this document may be verified at www.sgs.com/authentication. Any holder of this document is advised that information contained hereon reflects the Company's findings at the time of its intervention only and within the limits of client's instructions, if any. The Company's sole responsibility is to its Client and this document does not exonerate parties to a transaction from exercising all their rights and obligations under the transaction documents.

9. FIELD STRENGTH OF SPURIOUS RADIATION MEASUREMENT (TX)

9.1 Standard Applicable

According to FCC §2.1053,

FCC §22.917(a) the magnitude of each spurious and harmonic emission that can be detected when the equipment is operated under the conditions specified in the instruction manual and/or alignment procedure, shall not be less than $43 + 10 \log$ (mean output power in watts) dBc below the mean power output outside a license's frequency block (-13dBm)

9.2 EUT Setup (Block Diagram of Configuration)

Refer to section 6.2 in this report

9.3 Measurement Procedure

The EUT was placed on a non-conductive, The measurement antenna was placed at a distance of 3 meters from the EUT. During the tests, the antenna height and the EUT azimuth were varied in order to identify the maximum level of emissions from the EUT. This maximization process was repeated with the EUT positioned in each of its three orthogonal orientations.

The frequency range up to tenth harmonic was investigated for each of three fundamental frequency (low, middle and high channels). Once spurious emission were identified, the power of the emission was determined using the substitution method.

ERP in frequency band 824.2 –848.80MHz were measured using a substitution method. The EUT was replaced by dipole antenna connected, the S.G. output was recorded and ERP was calculated as follows:

The spurious emissions attenuation was calculated as the difference between radiated power at the fundamental frequency and the spurious emissions frequency.

$$\text{ERP} = \text{S.G. output (dBm)} + \text{Antenna Gain(dBd)} - \text{Cable Loss (dB)}$$

9.4 Measurement Equipment Used:

Refer to section 2.4 in this report

9.5 Measurement Result

Refer to attach tabular data sheets.

Radiated Spurious Emission Measurement Result: CDMA2000 Cellular Mode

Operation Mode	: TX CH 1013 H Mode	Test Date:	Nov. 02, 2010
Fundamental Frequency	: 824.70 MHz	Test By:	Jazz
Temperature	: 25	Pol:	Ver
Humidity	: 65%		

Freq. (MHz)	SPA Reading (dBuV)	Ant.Pol. H/V	S.G Out-put (dBm)	Antenna Gain (dBd/dBi)	Cable Loss (dB)	ERP/EIRP (dBm)	Limit (dBm)	Safe Margin (dBm)
69.77	42.40	V	-69.39	-1.07	1.16	-71.61	-13.00	-58.61
103.72	43.10	V	-58.48	-7.76	1.38	-67.62	-13.00	-54.62
141.55	30.10	V	-67.97	-7.79	1.55	-77.32	-13.00	-64.32
459.71	30.30	V	-63.67	-7.70	2.69	-74.06	-13.00	-61.06
578.05	30.40	V	-60.45	-7.78	3.00	-71.23	-13.00	-58.23
694.45	31.40	V	-57.98	-7.85	3.28	-69.11	-13.00	-56.11
824.00	78.90	V	-7.49	-7.87	3.62	-18.99	-13.00	-5.99
1649.40	44.50	V	-60.08	9.29	5.23	-56.02	-13.00	-43.02
2474.10	39.40	V	-61.60	10.08	6.53	-58.05	-13.00	-45.05
3298.80	44.40	V	-54.47	12.17	7.72	-50.01	-13.00	-37.01
4123.50	---	V		12.61	8.86		-13.00	
4948.20	---	V		12.65	9.74		-13.00	
5772.90	---	V		13.56	10.54		-13.00	
6597.60	---	V		12.04	11.30		-13.00	
7422.30	---	V		11.49	12.10		-13.00	
8247.00	---	V		11.48	12.72		-13.00	

Measurement uncertainty	30MHz - 80MHz: 5.04dB
	80MHz -1000MHz: 3.76dB
	1GHz - 13GHz: 4.45dB

Remark :

- 1 The emission behaviors belong to narrowband spurious emission.
- 2 Remark"---" means that the emission level is too low to be measured
- 3 The result basic equation calculation is as follows:
- 4 $ERP/EIRP (dBm) = SG \text{ Setting}(dBm) + Antenna \text{ Gain} (dB/dBi) - Cable \text{ loss} (dB)$

Unless otherwise stated the results shown in this test report refer only to the sample(s) tested and such sample(s) are retained for 90 days only. This test report cannot be reproduced, except in full, without prior written permission of the Company. 除非另有說明，此報告結果僅對測試之樣品負責，同時此樣品僅保留 90 天。本報告未經本公司書面許可，不可部份複製。 This document is issued by the Company subject to its General Conditions of Service (www.sgs.com/terms_and_conditions.htm) and Terms and Conditions for Electronic Documents (www.sgs.com/terms_e-document.htm). Attention is drawn to the limitations of liability, indemnification and jurisdictional issues established therein. Even if printed this electronic document is to be treated as an original within the meaning of UCP 600 article 20b. The authenticity of this document may be verified at www.sgs.com/authentication. Any holder of this document is advised that information contained hereon reflects the Company's findings at the time of its intervention only and within the limits of client's instructions, if any. The Company's sole responsibility is to its Client and this document does not exonerate parties to a transaction from exercising all their rights and obligations under the transaction documents.

Radiated Spurious Emission Measurement Result: CDMA2000 Cellular Mode

Operation Mode	: TX CH 1013 H Mode	Test Date:	Nov. 02, 2010
Fundamental Frequency	: 824.70 MHz	Test By:	Jazz
Temperature	: 25	Pol:	Hor
Humidity	: 65%		

Freq. (MHz)	SPA Reading (dBuV)	Ant.Pol. H/V	S.G Output (dBm)	Antenna Gain (dBd/dBi)	Cable Loss (dB)	ERP/EIRP (dBm)	Limit (dBm)	Safe Margin (dBm)
37.76	42.30	H	-61.19	-3.70	0.90	-65.80	-13.00	-52.80
103.72	40.20	H	-62.41	-7.76	1.38	-71.55	-13.00	-58.55
139.61	29.60	H	-69.26	-7.79	1.54	-78.59	-13.00	-65.59
423.82	31.10	H	-64.12	-7.68	2.58	-74.38	-13.00	-61.38
493.66	30.90	H	-62.61	-7.72	2.78	-73.11	-13.00	-60.11
700.27	31.20	H	-56.48	-7.86	3.29	-67.63	-13.00	-54.63
824.00	65.80	H	-20.47	-7.87	3.62	-31.97	-13.00	-18.97
1649.40	49.00	H	-55.40	9.29	5.23	-51.34	-13.00	-38.34
2474.10	44.10	H	-56.80	10.08	6.53	-53.26	-13.00	-40.26
3298.80	47.80	H	-51.29	12.17	7.72	-46.84	-13.00	-33.84
4123.50	---	H		12.61	8.86		-13.00	
4948.20	35.70	H	-56.92	12.65	9.74	-54.01	-13.00	-41.01
5772.90	---	H		13.56	10.54		-13.00	
6597.60	---	H		12.04	11.30		-13.00	
7422.30	---	H		11.49	12.10		-13.00	
8247.00	---	H		11.48	12.72		-13.00	

Measurement uncertainty	30MHz - 80MHz: 5.04dB
	80MHz -1000MHz: 3.76dB
	1GHz - 13GHz: 4.45dB

Remark :

- 1 The emission behaviors belong to narrowband spurious emission.
- 2 Remark”---“ means that the emission level is too low to be measured
- 3 The result basic equation calculation is as follows:
- 4 $ERP/EIRP (dBm) = SG \text{ Setting}(dBm) + Antenna \text{ Gain} (dB/dBi) - Cable \text{ loss} (dB)$

Unless otherwise stated the results shown in this test report refer only to the sample(s) tested and such sample(s) are retained for 90 days only. This test report cannot be reproduced, except in full, without prior written permission of the Company. 除非另有說明，此報告結果僅對測試之樣品負責，同時此樣品僅保留 90 天。本報告未經本公司書面許可，不可部份複製。 This document is issued by the Company subject to its General Conditions of Service (www.sgs.com/terms_and_conditions.htm) and Terms and Conditions for Electronic Documents (www.sgs.com/terms_e-document.htm). Attention is drawn to the limitations of liability, indemnification and jurisdictional issues established therein. Even if printed this electronic document is to be treated as an original within the meaning of UCP 600 article 20b. The authenticity of this document may be verified at www.sgonsite.com/authentication. Any holder of this document is advised that information contained hereon reflects the Company's findings at the time of its intervention only and within the limits of client's instructions, if any. The Company's sole responsibility is to its Client and this document does not exonerate parties to a transaction from exercising all their rights and obligations under the transaction documents.

Radiated Spurious Emission Measurement Result: CDMA2000 Cellular Mode

Operation Mode	: TX CH 384 H Mode	Test Date:	Nov. 02, 2010
Fundamental Frequency	: 836.52 MHz	Test By:	Jazz
Temperature	: 25°C	Pol:	Ver
Humidity	: 65%		

Freq. (MHz)	SPA. Reading (dBuV)	Ant.Pol. H/V	S.G Out-put (dBm)	Antenna Gain (dBd/dBi)	Cable Loss (dB)	ERP/EIRP (dBm)	Limit (dBm)	Safe Margin (dBm)
69.77	42.00	V	-69.79	-1.07	1.16	-72.01	-13.00	-59.01
103.72	42.00	V	-59.58	-7.76	1.38	-68.72	-13.00	-55.72
147.37	29.30	V	-68.23	-7.80	1.58	-77.61	-13.00	-64.61
462.62	31.60	V	-62.38	-7.71	2.70	-72.78	-13.00	-59.78
587.75	29.80	V	-60.49	-7.78	3.01	-71.28	-13.00	-58.28
699.30	31.20	V	-58.23	-7.86	3.29	-69.38	-13.00	-56.38
1673.04	41.30	V	-63.26	9.36	5.27	-59.17	-13.00	-46.17
2509.56	39.60	V	-61.18	10.09	6.58	-57.68	-13.00	-44.68
3346.08	46.30	V	-52.56	12.27	7.79	-48.08	-13.00	-35.08
4182.60	---	V		12.62	8.93		-13.00	
5019.12	---	V		12.67	9.81		-13.00	
5855.64	---	V		13.68	10.62		-13.00	
6692.16	---	V		11.95	11.39		-13.00	
7528.68	---	V		11.45	12.20		-13.00	
8365.20	---	V		11.59	12.81		-13.00	

Measurement uncertainty	30MHz - 80MHz: 5.04dB
	80MHz - 1000MHz: 3.76dB
	1GHz - 13GHz: 4.45dB

Remark :

- 1 The emission behaviors belongs to narrowband spurious emission.
- 2 Remark"---" means that the emission level is too low to be measured
- 3 The result basic equation calculation is as follows:
- 4 $ERP/EIRP (dBm) = SG \text{ Setting}(dBm) + Antenna \text{ Gain} (dB/dBi) - Cable \text{ loss} (dB)$

Unless otherwise stated the results shown in this test report refer only to the sample(s) tested and such sample(s) are retained for 90 days only. This test report cannot be reproduced, except in full, without prior written permission of the Company. 除非另有說明，此報告結果僅對測試之樣品負責，同時此樣品僅保留 90 天。本報告未經本公司書面許可，不可部份複製。 This document is issued by the Company subject to its General Conditions of Service (www.sgs.com/terms_and_conditions.htm) and Terms and Conditions for Electronic Documents (www.sgs.com/terms_e-document.htm). Attention is drawn to the limitations of liability, indemnification and jurisdictional issues established therein. Even if printed this electronic document is to be treated as an original within the meaning of UCP 600 article 20b. The authenticity of this document may be verified at www.sgsonsite.com/authentication. Any holder of this document is advised that information contained hereon reflects the Company's findings at the time of its intervention only and within the limits of client's instructions, if any. The Company's sole responsibility is to its Client and this document does not exonerate parties to a transaction from exercising all their rights and obligations under the transaction documents.

Radiated Spurious Emission Measurement Result: CDMA2000 Cellular Mode

Operation Mode	: TX CH 384 H Mode	Test Date:	Nov. 02, 2010
Fundamental Frequency	: 836.52 MHz	Test By:	Jazz
Temperature	: 25°C	Pol:	Hor
Humidity	: 65%		

Freq. (MHz)	SPA. Reading (dBuV)	Ant.Pol. H/V	S.G Out-put (dBm)	Antenna Gain (dBd/dBi)	Cable Loss (dB)	ERP/EIRP (dBm)	Limit (dBm)	Safe Margin (dBm)
37.76	42.30	H	-61.19	-3.70	0.90	-65.80	-13.00	-52.80
103.72	40.20	H	-62.41	-7.76	1.38	-71.55	-13.00	-58.55
139.61	29.60	H	-69.26	-7.79	1.54	-78.59	-13.00	-65.59
423.82	31.10	H	-64.12	-7.68	2.58	-74.38	-13.00	-61.38
493.66	30.90	H	-62.61	-7.72	2.78	-73.11	-13.00	-60.11
700.27	31.20	H	-56.48	-7.86	3.29	-67.63	-13.00	-54.63
1673.04	48.20	H	-56.18	9.36	5.27	-52.08	-13.00	-39.08
2509.56	43.20	H	-57.50	10.09	6.58	-54.00	-13.00	-41.00
3346.08	46.30	H	-52.76	12.27	7.79	-48.28	-13.00	-35.28
4182.60	41.60	H	-54.43	12.62	8.93	-50.74	-13.00	-37.74
5019.12	36.70	H	-55.62	12.67	9.81	-52.76	-13.00	-39.76
5855.64	---	H		13.68	10.62		-13.00	
6692.16	---	H		11.95	11.39		-13.00	
7528.68	---	H		11.45	12.20		-13.00	
8365.20	---	H		11.59	12.81		-13.00	

Measurement uncertainty	30MHz - 80MHz: 5.04dB
	80MHz - 1000MHz: 3.76dB
	1GHz - 13GHz: 4.45dB

Remark :

- 1 The emission behaviors belong to narrowband spurious emission.
- 2 Remark"---" means that the emission level is too low to be measured
- 3 The result basic equation calculation is as follows:
- 4 $ERP/EIRP (dBm) = SG \text{ Setting}(dBm) + Antenna \text{ Gain} (dB/dBi) - Cable \text{ loss} (dB)$

Unless otherwise stated the results shown in this test report refer only to the sample(s) tested and such sample(s) are retained for 90 days only. This test report cannot be reproduced, except in full, without prior written permission of the Company. 除非另有說明，此報告結果僅對測試之樣品負責，同時此樣品僅保留 90 天。本報告未經本公司書面許可，不可部份複製。 This document is issued by the Company subject to its General Conditions of Service (www.sgs.com/terms_and_conditions.htm) and Terms and Conditions for Electronic Documents (www.sgs.com/terms_e-document.htm). Attention is drawn to the limitations of liability, indemnification and jurisdictional issues established therein. Even if printed this electronic document is to be treated as an original within the meaning of UCP 600 article 20b. The authenticity of this document may be verified at www.sgsonsite.com/authentication. Any holder of this document is advised that information contained hereon reflects the Company's findings at the time of its intervention only and within the limits of client's instructions, if any. The Company's sole responsibility is to its Client and this document does not exonerate parties to a transaction from exercising all their rights and obligations under the transaction documents.

Radiated Spurious Emission Measurement Result: CDMA2000 Cellular Mode

Operation Mode	: TX CH 777 H Mode	Test Date:	Nov. 02, 2010
Fundamental Frequency	: 848.31 MHz	Test By:	Jazz
Temperature	: 25	Pol:	Ver
Humidity	: 65%		

Freq. (MHz)	SPA. Reading (dBuV)	Ant.Pol. H/V	S.G Output (dBm)	Antenna Gain (dBd/dBi)	Cable Loss (dB)	ERP/EIRP (dBm)	Limit (dBm)	Safe Margin (dBm)
69.77	42.10	V	-69.69	-1.07	1.16	-71.91	-13.00	-58.91
104.69	41.20	V	-60.29	-7.76	1.38	-69.43	-13.00	-56.43
131.85	30.60	V	-68.37	-7.79	1.51	-77.66	-13.00	-64.66
425.76	30.00	V	-64.69	-7.68	2.59	-74.96	-13.00	-61.96
500.45	30.50	V	-63.63	-7.72	2.80	-74.15	-13.00	-61.15
699.30	31.50	V	-57.93	-7.86	3.29	-69.08	-13.00	-56.08
849.00	76.10	V	-10.02	-7.88	3.68	-21.58	-13.00	-8.58
1696.62	43.70	V	-60.84	9.43	5.31	-56.71	-13.00	-43.71
2544.93	39.40	V	-61.25	10.19	6.63	-57.69	-13.00	-44.69
3393.24	41.10	V	-57.75	12.38	7.86	-53.24	-13.00	-40.24
4241.55	---	V		12.63	9.00		-13.00	
5089.86	---	V		12.74	9.88		-13.00	
5938.17	---	V		13.81	10.70		-13.00	
6786.48	---	V		11.86	11.48		-13.00	
7634.79	---	V		11.41	12.27		-13.00	
8483.10	---	V		11.69	12.91		-13.00	

Measurement uncertainty	30MHz - 80MHz: 5.04dB
	80MHz - 1000MHz: 3.76dB
	1GHz - 13GHz: 4.45dB

Remark :

- 1 The emission behaviors belong to narrowband spurious emission.
- 2 Remark"---" means that the emission level is too low to be measured
- 3 The result basic equation calculation is as follows:
- 4 $ERP/EIRP (dBm) = SG \text{ Setting}(dBm) + Antenna \text{ Gain} (dB/dBi) - Cable \text{ loss} (dB)$

Unless otherwise stated the results shown in this test report refer only to the sample(s) tested and such sample(s) are retained for 90 days only. This test report cannot be reproduced, except in full, without prior written permission of the Company. 除非另有說明，此報告結果僅對測試之樣品負責，同時此樣品僅保留 90 天。本報告未經本公司書面許可，不可部份複製。 This document is issued by the Company subject to its General Conditions of Service (www.sgs.com/terms_and_conditions.htm) and Terms and Conditions for Electronic Documents (www.sgs.com/terms_e-document.htm). Attention is drawn to the limitations of liability, indemnification and jurisdictional issues established therein. Even if printed this electronic document is to be treated as an original within the meaning of UCP 600 article 20b. The authenticity of this document may be verified at www.sgsonsite.com/authentication. Any holder of this document is advised that information contained hereon reflects the Company's findings at the time of its intervention only and within the limits of client's instructions, if any. The Company's sole responsibility is to its Client and this document does not exonerate parties to a transaction from exercising all their rights and obligations under the transaction documents.

10. FREQUENCY STABILITY V.S. TEMPERATURE MEASUREMENT

10.1 Standard Applicable

According to FCC §2.1055(a)(1)

Frequency Tolerance: +/- 2.5 ppm

10.2 Test Set-up:

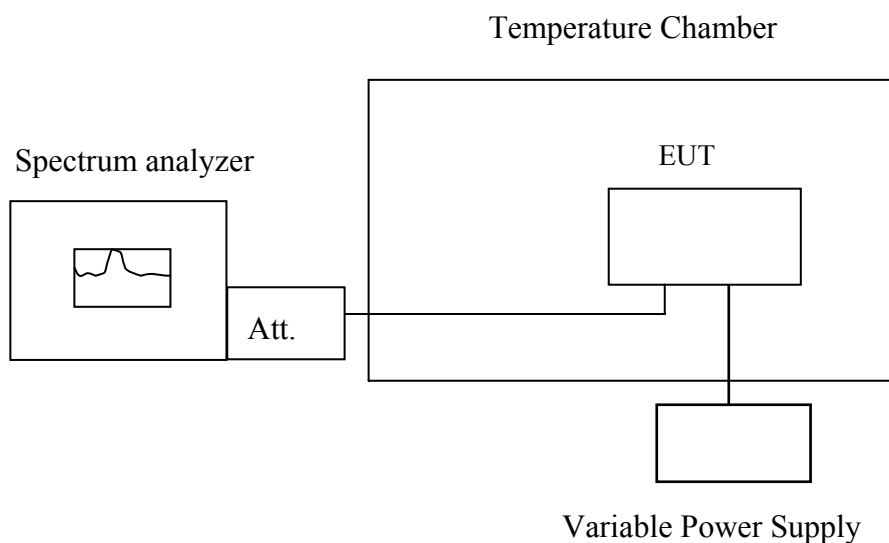

Note : Measurement setup for testing on Antenna connector

10.3 Measurement Procedure

The equipment under test was connected to an external AC or DC power supply and input rated voltage. RF output was connected to a frequency counter or spectrum analyzer via feed through attenuators. The EUT was placed inside the temperature chamber. Set the spectrum analyzer RBW low enough to obtain the desired frequency resolution and measure EUT 25°C operating frequency as reference frequency. Turn EUT off and set the chamber temperature to -30°C. After the temperature stabilized for approximately 30 minutes recorded the frequency. Repeat step measure with 10°C increased per stage until the highest temperature of +50°C reached.

10.4 Measurement Equipment Used:

Refer to section 2.4 in this report

10.5 Measurement Result

Reference Frequency: CDMA2000 Cellular Band Mid Channel 836.52 MHz @ 25°C				
Limit: +/- 2.5 ppm = 2091 Hz				
Power Supply	Environment	Frequency	Delta (Hz)	Limit (Hz)
Vdc	Temperature (°C)	(MHz)		
3.7	-30	836.519997	-1.00	2091
3.7	-20	836.519996	-2.00	2091
3.7	-10	836.519998	0.00	2091
3.7	0	836.519997	-1.00	2091
3.7	10	836.519996	-2.00	2091
3.7	20	836.519998	0.00	2091
3.7	30	836.520001	3.00	2091
3.7	40	836.519999	1.00	2091
3.7	50	836.519997	-1.00	2091

Unless otherwise stated the results shown in this test report refer only to the sample(s) tested and such sample(s) are retained for 90 days only. This test report cannot be reproduced, except in full, without prior written permission of the Company. 除非另有說明，此報告結果僅對測試之樣品負責，同時此樣品僅保留 90 天。本報告未經本公司書面許可，不可部份複製。 This document is issued by the Company subject to its General Conditions of Service (www.sgs.com/terms_and_conditions.htm) and Terms and Conditions for Electronic Documents (www.sgs.com/terms_e-document.htm). Attention is drawn to the limitations of liability, indemnification and jurisdictional issues established therein. Even if printed this electronic document is to be treated as an original within the meaning of UCP 600 article 20b. The authenticity of this document may be verified at www.sgsonsite.com/authentication. Any holder of this document is advised that information contained hereon reflects the Company's findings at the time of its intervention only and within the limits of client's instructions, if any. The Company's sole responsibility is to its Client and this document does not exonerate parties to a transaction from exercising all their rights and obligations under the transaction documents.

11. FREQUENCY STABILITY V.S. VOLTAGE MEASUREMENT

11.1 Standard Applicable

According to FCC §2.1055(d)(2)

Frequency Tolerance: +/- 2.5 ppm

11.2 Test Set-up:

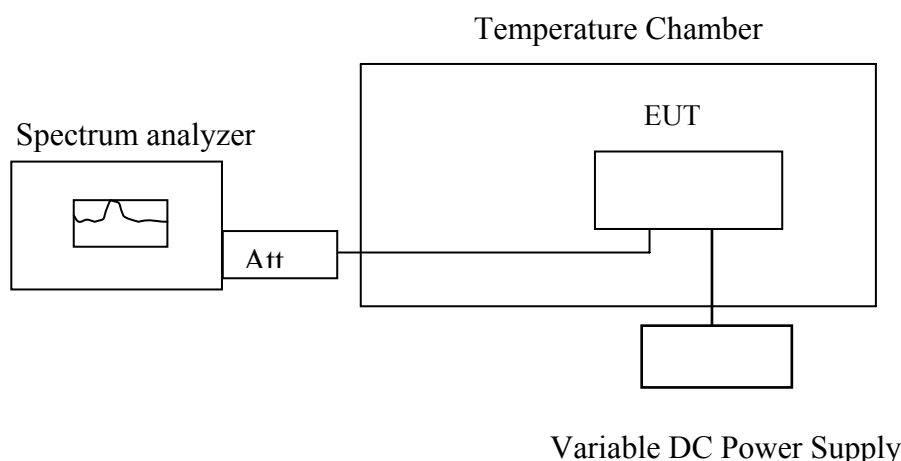

Note: Measurement setup for testing on Antenna connector

11.3 Measurement Procedure

Set chamber temperature to 25°C. Use a variable AC power supply / DC power source to power the EUT and set the voltage to rated voltage. Set the spectrum analyzer RBW low enough to obtain the desired frequency resolution and recorded the frequency.

Reduce the input voltage to specified extreme voltage variation (+/- 15%) and endpoint, record the maximum frequency change.

11.4 Measurement Equipment Used:

Refer to section 2.4 in this report

11.5 Measurement Result

Reference Frequency: CDMA2000 Cellular Band Mid Channel 836.52 MHz @ 25°C				
Limit: +/- 2.5 ppm = 2091 Hz				
Power Supply	Environment	Frequency	Delta (Hz)	Limit (Hz)
Vdc	Temperature (°C)	(MHz)		
4.200	25.00	836.519999	1.00	2091.00
3.700	25.00	836.519998	0.00	2091.00
3.145	25.00	836.519997	-1.00	2091.00
2.90 (End Point)	25.00	836.519990	-8.00	2091.00

Unless otherwise stated the results shown in this test report refer only to the sample(s) tested and such sample(s) are retained for 90 days only. This test report cannot be reproduced, except in full, without prior written permission of the Company. 除非另有說明，此報告結果僅對測試之樣品負責，同時此樣品僅保留 90 天。本報告未經本公司書面許可，不可部份複製。 This document is issued by the Company subject to its General Conditions of Service (www.sgs.com/terms_and_conditions.htm) and Terms and Conditions for Electronic Documents (www.sgs.com/terms_e-document.htm). Attention is drawn to the limitations of liability, indemnification and jurisdictional issues established therein. Even if printed this electronic document is to be treated as an original within the meaning of UCP 600 article 20b. The authenticity of this document may be verified at www.sgsonsite.com/authentication. Any holder of this document is advised that information contained hereon reflects the Company's findings at the time of its intervention only and within the limits of client's instructions, if any. The Company's sole responsibility is to its Client and this document does not exonerate parties to a transaction from exercising all their rights and obligations under the transaction documents.