



FCC TEST REPORT (WLAN 15.407)

REPORT NO.: RF130823C23A-3

MODEL NO.: FJT21

FCC ID: YUW-FJT21

RECEIVED: Aug. 29, 2013

TESTED: Sep. 19 ~ Oct. 10, 2013

ISSUED: Oct. 15, 2013

APPLICANT: Fujitsu Mobile Communications Ltd.

ADDRESS: 1-1, Kamikodanaka 4-chome, Nakahara-ku,
Kawasaki 211-8588, Japan

ISSUED BY: Bureau Veritas Consumer Products Services
(H.K.) Ltd., Taoyuan Branch

LAB ADDRESS: No. 47, 14th Ling, Chia Pau Vil., Lin Kou Dist.,
New Taipei City, Taiwan, R.O.C.

TEST LOCATION: No. 19, Hwa Ya 2nd Rd, Wen Hwa Tsuen, Kwei
Shan Hsiang, Taoyuan Hsien 333, Taiwan, R.O.C.

This report should not be used by the client to claim product certification, approval, or endorsement by TAF or any government agencies.



This report is for your exclusive use. Any copying or replication of this report to or for any other person or entity, or use of our name or trademark, is permitted only with our prior written permission. This report sets forth our findings solely with respect to the test samples identified herein. The results set forth in this report are not indicative or representative of the quality or characteristics of the lot from which a test sample was taken or any similar or identical product unless specifically and expressly noted. Our report includes all of the tests requested by you and the results thereof based upon the information that you provided to us. You have 60 days from date of issuance of this report to notify us of any material error or omission caused by our negligence, provided, however, that such notice shall be in writing and shall specifically address the issue you wish to raise. A failure to raise such issue within the prescribed time shall constitute your unqualified acceptance of the completeness of this report, the tests conducted and the correctness of the report contents. Unless specific mention, the uncertainty of measurement has been explicitly taken into account to declare the compliance or non-compliance to the specification.



TABLE OF CONTENTS

RELEASE CONTROL RECORD.....	4
1. CERTIFICATION.....	5
2. SUMMARY OF TEST RESULTS.....	6
2.1 MEASUREMENT UNCERTAINTY.....	6
3. GENERAL INFORMATION.....	7
3.1 GENERAL DESCRIPTION OF EUT.....	7
3.2 DESCRIPTION OF TEST MODES.....	9
3.2.1 TEST MODE APPLICABILITY AND TESTED CHANNEL DETAIL.....	11
3.3 DUTY CYCLE OF TEST SIGNAL.....	13
3.4 DESCRIPTION OF SUPPORT UNITS.....	18
3.4.1 CONFIGURATION OF SYSTEM UNDER TEST.....	18
3.5 GENERAL DESCRIPTION OF APPLIED STANDARDS.....	20
4. TEST TYPES AND RESULTS.....	21
4.1 RADIATED EMISSION AND BANDEDGE MEASUREMENT.....	21
4.1.1 LIMITS OF RADIATED EMISSION AND BANDEDGE MEASUREMENT.....	21
4.1.2 LIMITS OF UNWANTED EMISSION OUT OF THE RESTRICTED BANDS.....	21
4.1.3 TEST INSTRUMENTS.....	22
4.1.4 TEST PROCEDURES.....	23
4.1.5 DEVIATION FROM TEST STANDARD.....	23
4.1.6 TEST SETUP.....	24
4.1.7 EUT OPERATING CONDITION.....	25
4.1.8 TEST RESULTS.....	26
4.2 CONDUCTED EMISSION MEASUREMENT.....	60
4.2.1 LIMITS OF CONDUCTED EMISSION MEASUREMENT.....	60
4.2.2 TEST INSTRUMENTS.....	60
4.2.3 TEST PROCEDURES.....	61
4.2.4 DEVIATION FROM TEST STANDARD.....	61
4.2.5 TEST SETUP.....	61
4.2.6 EUT OPERATING CONDITIONS.....	61
4.2.7 TEST RESULTS.....	62
4.3 PEAK TRANSMIT POWER MEASUREMENT.....	74
4.3.1 LIMITS OF PEAK TRANSMIT POWER MEASUREMENT.....	74
4.3.2 TEST SETUP.....	74
4.3.3 TEST INSTRUMENTS.....	75
4.3.4 TEST PROCEDURE.....	75
4.3.5 DEVIATION FROM TEST STANDARD.....	76
4.3.6 EUT OPERATING CONDITIONS.....	76
4.3.7 TEST RESULTS.....	77
4.4 PEAK POWER SPECTRAL DENSITY MEASUREMENT.....	82
4.4.1 LIMITS OF PEAK POWER SPECTRAL DENSITY MEASUREMENT.....	82
4.4.2 TEST SETUP.....	82
4.4.3 TEST INSTRUMENTS.....	82
4.4.4 TEST PROCEDURES.....	83
4.4.5 DEVIATION FROM TEST STANDARD.....	83
4.4.6 EUT OPERATING CONDITIONS.....	83
4.4.7 TEST RESULTS.....	84
4.5 PEAK POWER EXCURSION MEASUREMENT.....	86
4.5.1 LIMITS OF PEAK POWER EXCURSION MEASUREMENT.....	86
4.5.2 TEST SETUP.....	86



A D T

4.5.3	TEST INSTRUMENTS	86
4.5.4	TEST PROCEDURE	86
4.5.5	DEVIATION FROM TEST STANDARD	86
4.5.6	EUT OPERATING CONDITIONS	86
4.5.7	TEST RESULTS	87
4.6	FREQUENCY STABILITY	88
4.6.1	LIMITS OF FREQUENCY STABILITY MEASUREMENT	88
4.6.2	TEST SETUP	88
4.6.3	TEST INSTRUMENTS	88
4.6.4	TEST PROCEDURE	89
4.6.5	DEVIATION FROM TEST STANDARD	89
4.6.6	EUT OPERATING CONDITION	89
4.6.7	TEST RESULTS	90
5.	PHOTOGRAPHS OF THE TEST CONFIGURATION	91
6.	INFORMATION ON THE TESTING LABORATORIES	92
7.	APPENDIX A – MODIFICATIONS RECORDERS FOR ENGINEERING CHANGES TO THE EUT BY THE LAB	93



A D T

RELEASE CONTROL RECORD

ISSUE NO.	REASON FOR CHANGE	DATE ISSUED
RF130823C23A-3	Original release.	Oct. 15, 2013



1. CERTIFICATION

PRODUCT: Tablet PC

MODEL: FJT21

BRAND: FUJITSU

APPLICANT: Fujitsu Mobile Communications Ltd.

TESTED: Sep. 19 ~ Oct. 10, 2013

TEST SAMPLE: ENGINEERING SAMPLE

STANDARDS: FCC Part 15, Subpart E (Section 15.407)

ANSI C63.10-2009

The above equipment (model: FJT21) has been tested by **Bureau Veritas Consumer Products Services (H.K.) Ltd., Taoyuan Branch**, and found compliance with the requirement of the above standards. The test record, data evaluation & Equipment Under Test (EUT) configurations represented herein are true and accurate accounts of the measurements of the sample's EMC characteristics under the conditions specified in this report.

PREPARED BY : Suntee Liu , **DATE :** Oct. 15, 2013
Suntee Liu / Specialist

APPROVED BY : Ken Liu , **DATE :** Oct. 15, 2013
Ken Liu / Senior Manager

2. SUMMARY OF TEST RESULTS

The EUT has been tested according to the following specifications:

APPLIED STANDARD: FCC PART 15, SUBPART E (SECTION 15.407)			
STANDARD SECTION	TEST TYPE	RESULT	REMARK
15.407(b)(6)	AC Power Conducted Emission	PASS	Meet the requirement of limit. Minimum passing margin is -6.85dB at 0.49239MHz.
15.407(b)(1/2/3) (b)(6)	Radiated Emissions	PASS	Meet the requirement of limit. Minimum passing margin is -1.9dB at 37.66MHz.
15.407(a)(1/2)	Max Average Transmit Power	PASS	Meet the requirement of limit.
15.407(a)(6)	Peak Power Excursion	PASS	Meet the requirement of limit.
15.407(a)(1/2)	Peak Power Spectral Density	PASS	Meet the requirement of limit.
15.407(g)	Frequency Stability	PASS	Meet the requirement of limit.
15.203	Antenna Requirement	PASS	No antenna connector is used.

2.1 MEASUREMENT UNCERTAINTY

Where relevant, the following measurement uncertainty levels have been estimated for tests performed on the EUT as specified in CISPR 16-4-2:

MEASUREMENT	FREQUENCY	UNCERTAINTY
Conducted emissions	9kHz~30MHz	2.44 dB
Radiated emissions	30MHz ~ 200MHz	3.34 dB
	200MHz ~1000MHz	3.35 dB
	1GHz ~ 18GHz	2.26 dB
	18GHz ~ 40GHz	1.94 dB

This uncertainty represents an expanded uncertainty expressed at approximately the 95% confidence level using a coverage factor of $k = 2$.

3. GENERAL INFORMATION

3.1 GENERAL DESCRIPTION OF EUT

EUT	Tablet PC
MODEL NO.	FJT21
POWER SUPPLY	3.8Vdc (battery) 5Vdc (adapter or host equipment) 12Vdc (cradle)
MODULATION TYPE	256QAM, 64QAM, 16QAM, QPSK, BPSK
MODULATION TECHNOLOGY	OFDM
TRANSFER RATE	802.11a: 54/48/36/24/18/12/9/6Mbps 802.11n: up to 72.2Mbps 802.11ac: up to 433.3Mbps
OPERATING FREQUENCY	5180 ~ 5240MHz, 5260 ~ 5320MHz & 5500 ~ 5700MHz
NUMBER OF CHANNEL	5180 ~ 5240MHz: 4 for 802.11a, 802.11n (20MHz) 2 for 802.11n (40MHz) 1 for 802.11ac (80MHz) 5260 ~ 5320MHz: 4 for 802.11a, 802.11n (20MHz) 2 for 802.11n (40MHz) 1 for 802.11ac (80MHz) 5500 ~ 5700MHz: 8 for 802.11a, 802.11n (20MHz) 3 for 802.11n (40MHz) 1 for 802.11ac (80MHz)
OUTPUT POWER	15.560mW for 5180 ~ 5240MHz 15.205mW for 5260 ~ 5320MHz 15.382mW for 5500 ~ 5700MHz
ANTENNA TYPE	$\lambda/4$ Monopole antenna with -2dBi gain
ANTENNA CONNECTOR	NA
DATA CABLE	NA
I/O PORTS	Refer to user's manual
ACCESSORY DEVICES	Refer to Note

NOTE:

1. The EUT provides one completed transmitter and one receiver.

MODULATION MODE	TX FUNCTION
802.11a	1TX
802.11n (20MHz)	1TX
802.11n (40MHz)	1TX
802.11ac (80MHz)	1TX

2. The EUT contains following accessories.

No.	Product	Brand	Model	Description
1	Cradle	KDDI CORPORATION	FJT21PUA	Input: 12.0V, 2000mA Output: 12.0V, 2000mA
2	Cradle's adapter	KDDI CORPORATION	FJL22PQA	Input: 100-240Vac, 1000mA Output: 12.0Vdc, 3000mA 1m non-shielded AC cable without core 1.8m non-shielded DC cable with 1 core
3	Battery	Fujitsu Limited	CA54310-0048	3.8Vdc, 9600mA

3. The EUT uses following support unit.

No.	Product	Brand	Model	Description
1	Adapter	NTT docomo	AC Adaptor 04	Input: 100-240Vac, 0.22A, 50-60Hz Output: 5.0V, 1.8A 1.05m DC cable with 2 cores

4. SW version is R17.1e.
5. HW version is V2.0.0.
6. IMEI Code: 357674050004069, 357674050004143.
7. IEEE 802.11ac is still draft version.
8. The above EUT information is declared by manufacturer and for more detailed features description, please refer to the manufacturer's specifications or user's manual.

3.2 DESCRIPTION OF TEST MODES

FOR 5180 ~ 5240MHz

4 channels are provided for 802.11a, 802.11n (20MHz):

CHANNEL	FREQUENCY	CHANNEL	FREQUENCY
36	5180 MHz	44	5220 MHz
40	5200 MHz	48	5240 MHz

2 channels are provided for 802.11n (40MHz):

CHANNEL	FREQUENCY	CHANNEL	FREQUENCY
38	5190 MHz	46	5230 MHz

1 channel is provided for 802.11ac (80MHz):

CHANNEL	FREQUENCY
42	5210MHz

FOR 5260 ~ 5320MHz

4 channels are provided for 802.11a, 802.11n (20MHz):

CHANNEL	FREQUENCY	CHANNEL	FREQUENCY
52	5260 MHz	60	5300 MHz
56	5280 MHz	64	5320 MHz

2 channels are provided for 802.11n (40MHz):

CHANNEL	FREQUENCY	CHANNEL	FREQUENCY
54	5270 MHz	62	5310 MHz

1 channel is provided for 802.11ac (80MHz):

CHANNEL	FREQUENCY
58	5290MHz



FOR 5500 ~ 5700MHz

8 channels are provided for 802.11a, 802.11n (20MHz):

CHANNEL	FREQUENCY	CHANNEL	FREQUENCY
100	5500 MHz	116	5580 MHz
104	5520 MHz	132	5660 MHz
108	5540 MHz	136	5680 MHz
112	5560 MHz	140	5700 MHz

3 channels are provided for 802.11n (40MHz):

CHANNEL	FREQUENCY	CHANNEL	FREQUENCY
102	5510 MHz	134	5670 MHz
110	5550 MHz		

1 channel is provided for 802.11ac (80MHz):

CHANNEL	FREQUENCY
106	5530MHz

3.2.1 TEST MODE APPLICABILITY AND TESTED CHANNEL DETAIL

EUT CONFIGURE MODE	APPLICABLE TO				DESCRIPTION
	RE \geq 1G	RE<1G	PLC	APCM	
A	√	√	√	√	Power from adapter
B	-	√	√	-	Power from cradle
C	-	√	√	-	Power from host equipment

Where **RE \geq 1G**: Radiated Emission above 1GHz **RE<1G**: Radiated Emission below 1GHz
PLC: Power Line Conducted Emission **APCM**: Antenna Port Conducted Measurement

NOTE 1: "-" means no effect.

NOTE 2: The EUT had been pre-tested on the positioned of each 3 axis. The worst case was found when positioned on Y-plane.

RADIATED EMISSION TEST (ABOVE 1GHz):

- Pre-Scan has been conducted to determine the worst-case mode from all possible combinations between available modulations, data rates and antenna ports (if EUT with antenna diversity architecture).
- Following channel(s) was (were) selected for the final test as listed below.

EUT CONFIGURE MODE	MODE	FREQ. BAND (MHz)	AVAILABLE CHANNEL	TESTED CHANNEL	MODULATION TECHNOLOGY	MODULATION TYPE	DATA RATE (Mbps)
A	802.11a	5180-5240	36 to 48	36, 40, 48	OFDM	BPSK	6.0
A	802.11n (20MHz)		36 to 48	36, 40, 48	OFDM	BPSK	7.2
A	802.11n (40MHz)		38 to 46	38, 46	OFDM	BPSK	15.0
A	802.11ac (80MHz)		42	42	OFDM	BPSK	32.5
A	802.11a	5260-5320	52 to 64	52, 60, 64	OFDM	BPSK	6.0
A	802.11n (20MHz)		52 to 64	52, 60, 64	OFDM	BPSK	7.2
A	802.11n (40MHz)		54 to 62	54, 62	OFDM	BPSK	15.0
A	802.11ac (80MHz)		58	58	OFDM	BPSK	32.5
A	802.11a	5500-5700	100 to 140	100, 116, 140	OFDM	BPSK	6.0
A	802.11n (20MHz)		100 to 140	100, 116, 140	OFDM	BPSK	7.2
A	802.11n (40MHz)		102 to 134	102, 110, 134	OFDM	BPSK	15.0
A	802.11ac (80MHz)		106	106	OFDM	BPSK	32.5

RADIATED EMISSION TEST (BELOW 1GHz):

- Pre-Scan has been conducted to determine the worst-case mode from all possible combinations between available modulations, data rates and antenna ports (if EUT with antenna diversity architecture).
- Following channel(s) was (were) selected for the final test as listed below.

EUT CONFIGURE MODE	MODE	FREQ. BAND (MHz)	AVAILABLE CHANNEL	TESTED CHANNEL	MODULATION TECHNOLOGY	MODULATION TYPE	DATA RATE (Mbps)
A, B, C	802.11a	5180-5320	36 to 64	48	OFDM	BPSK	6.0
A, B, C	802.11a	5500-5700	100 to 140	100	OFDM	BPSK	6.0

POWER LINE CONDUCTED EMISSION TEST:

- Pre-Scan has been conducted to determine the worst-case mode from all possible combinations between available modulations, data rates and antenna ports (if EUT with antenna diversity architecture).
- Following channel(s) was (were) selected for the final test as listed below.

EUT CONFIGURE MODE	MODE	FREQ. BAND (MHz)	AVAILABLE CHANNEL	TESTED CHANNEL	MODULATION TECHNOLOGY	MODULATION TYPE	DATA RATE (Mbps)
A, B, C	802.11a	5180-5320	36 to 64	48	OFDM	BPSK	6.0
A, B, C	802.11a	5500-5700	100 to 140	100	OFDM	BPSK	6.0

ANTENNA PORT CONDUCTED MEASUREMENT:

- This item includes all test value of each mode, but only includes spectrum plot of worst value of each mode.
- Pre-Scan has been conducted to determine the worst-case mode from all possible combinations between available modulations, data rates and antenna ports (if EUT with antenna diversity architecture).
- Following channel(s) was (were) selected for the final test as listed below.

EUT CONFIGURE MODE	MODE	FREQ. BAND (MHz)	AVAILABLE CHANNEL	TESTED CHANNEL	MODULATION TECHNOLOGY	MODULATION TYPE	DATA RATE (Mbps)
A	802.11a	5180-5240	36 to 48	36, 40, 48	OFDM	BPSK	6.0
A	802.11n (20MHz)		36 to 48	36, 40, 48	OFDM	BPSK	7.2
A	802.11n (40MHz)		38 to 46	38, 46	OFDM	BPSK	15.0
A	802.11ac (80MHz)		42	42	OFDM	BPSK	32.5
A	802.11a	5260-5320	52 to 64	52, 60, 64	OFDM	BPSK	6.0
A	802.11n (20MHz)		52 to 64	52, 60, 64	OFDM	BPSK	7.2
A	802.11n (40MHz)		54 to 62	54, 62	OFDM	BPSK	15.0
A	802.11ac (80MHz)		58	58	OFDM	BPSK	32.5
A	802.11a	5500-5700	100 to 140	100, 116, 140	OFDM	BPSK	6.0
A	802.11n (20MHz)		100 to 140	100, 116, 140	OFDM	BPSK	7.2
A	802.11n (40MHz)		102 to 134	102, 110, 134	OFDM	BPSK	15.0
A	802.11ac (80MHz)		106	106	OFDM	BPSK	32.5

TEST CONDITION:

APPLICABLE TO	ENVIRONMENTAL CONDITIONS	INPUT POWER	TESTED BY
RE≥1G	24deg. C, 77%RH	120Vac, 60Hz	Martin Lee
RE<1G	25deg. C, 65%RH	120Vac, 60Hz	Chris Lin
PLC	25deg. C, 65%RH	120Vac, 60Hz	Jones Chang
APCM	25deg. C, 60%RH	120Vac, 60Hz	Jun Wu

3.3 DUTY CYCLE OF TEST SIGNAL

MODULATION TYPE: BPSK

If duty cycle is < 98%, duty factor shall be considered.

802.11a: Duty cycle of test signal is > 98 %, duty factor is not required.

802.11n (20MHz): Duty cycle of test signal is > 98 %, duty factor is not required.

802.11n (40MHz): Duty cycle of test signal is > 98 %, duty factor is not required.

802.11ac (80MHz): Duty cycle = 0.248/0.258 = 0.961, Duty factor = $10 * \log(1/0.961) = 0.17$

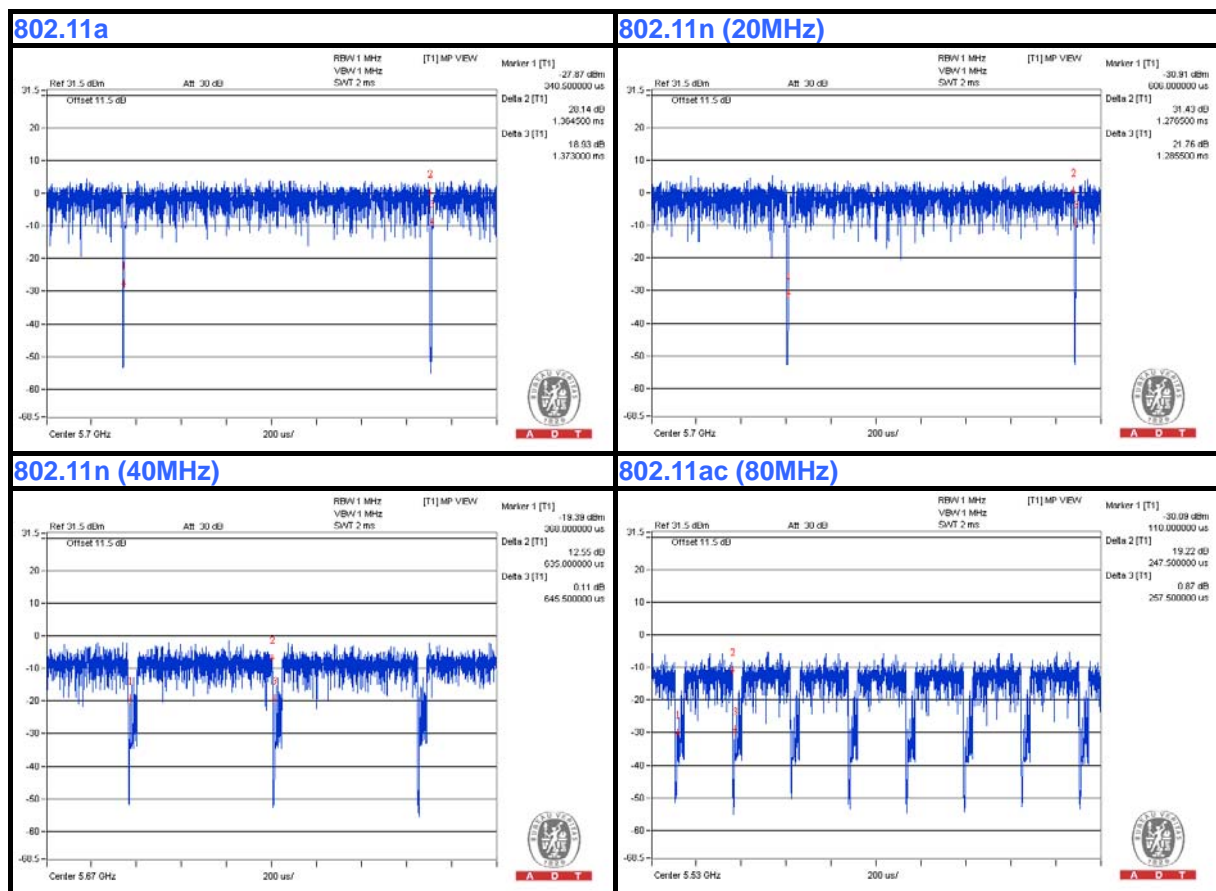

MODULATION TYPE: QPSK

If duty cycle is < 98%, duty factor shall be considered.

802.11a: Duty cycle of test signal is > 98 %, duty factor is not required.

802.11n (20MHz): Duty cycle of test signal is > 98 %, duty factor is not required.

802.11n (40MHz): Duty cycle = 0.338/0.348 = 0.971, Duty factor = $10 * \log(1/0.971) = 0.13$

802.11ac (80MHz): Duty cycle = 0.143/0.154 = 0.929, Duty factor = $10 * \log(1/0.929) = 0.32$

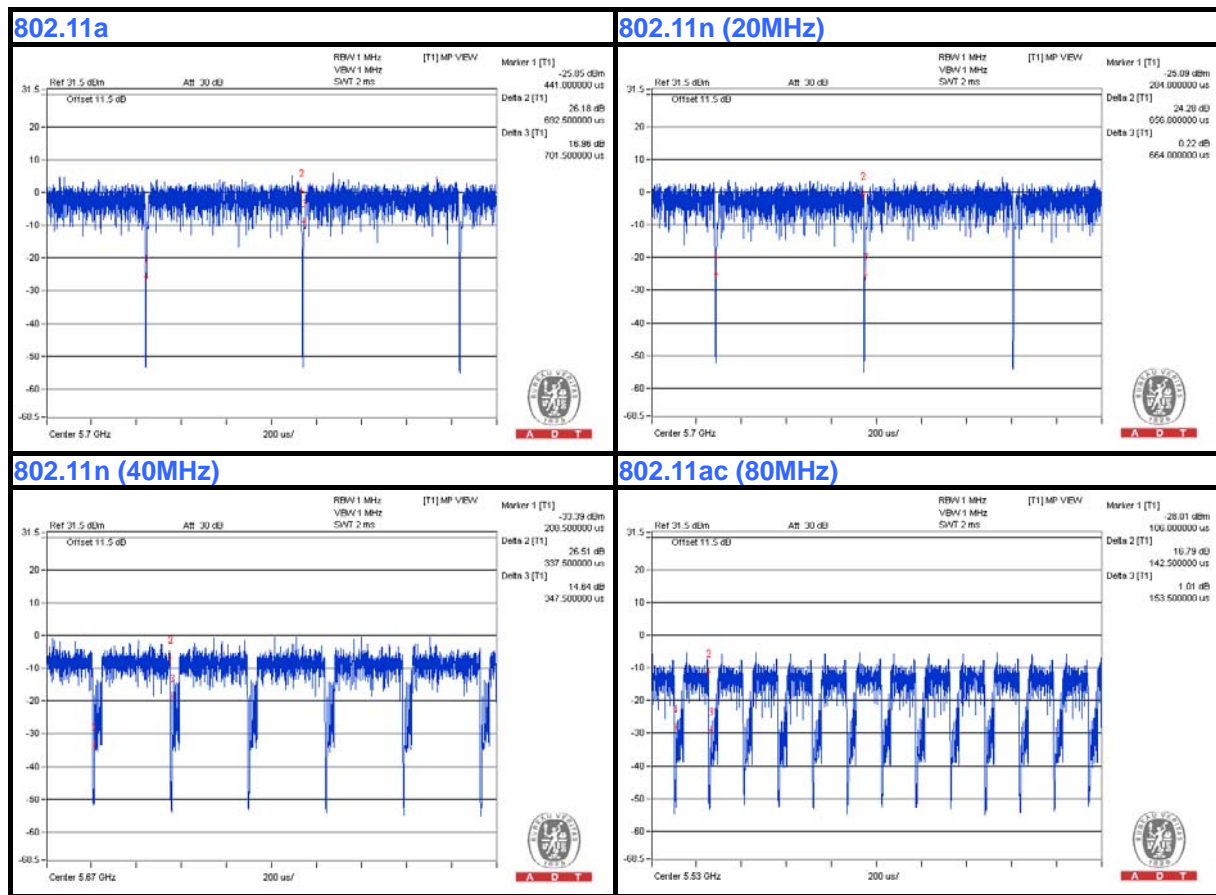



A D T

MODULATION TYPE: 16QAM

If duty cycle is < 98%, duty factor shall be considered.

802.11a: Duty cycle = $0.357/0.365 = 0.978$, Duty factor = $10 * \log(1/0.978) = 0.10$

802.11n (20MHz): Duty cycle of test signal is > 98 %, duty factor is not required.

802.11n (40MHz): Duty cycle = $0.189/0.199 = 0.950$, Duty factor = $10 * \log(1/0.950) = 0.22$

802.11ac (80MHz): Duty cycle = $0.091/0.104 = 0.875$, Duty factor = $10 * \log(1/0.875) = 0.58$

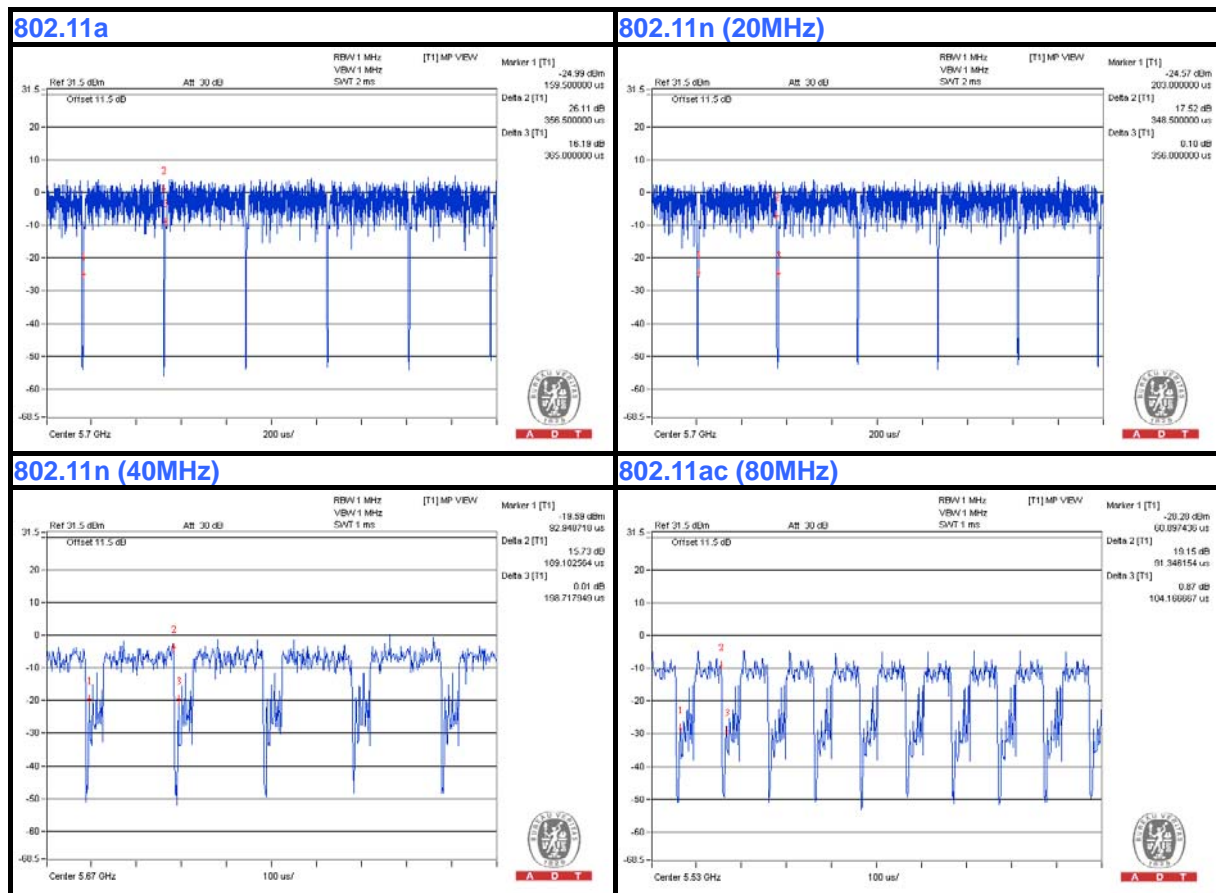



A D T

MODULATION TYPE: 64QAM

If duty cycle is < 98%, duty factor shall be considered.

802.11a: Duty cycle = 0.189/0.198 = 0.955, Duty factor = $10 * \log(1/0.955) = 0.20$

802.11n (20MHz): Duty cycle = 0.192/0.200 = 0.960, Duty factor = $10 * \log(1/0.960) = 0.18$

802.11n (40MHz): Duty cycle = 0.111/0.122 = 0.910, Duty factor = $10 * \log(1/0.910) = 0.41$

802.11ac (80MHz): Duty cycle = 0.028/0.040 = 0.700, Duty factor = $10 * \log(1/0.700) = 1.55$

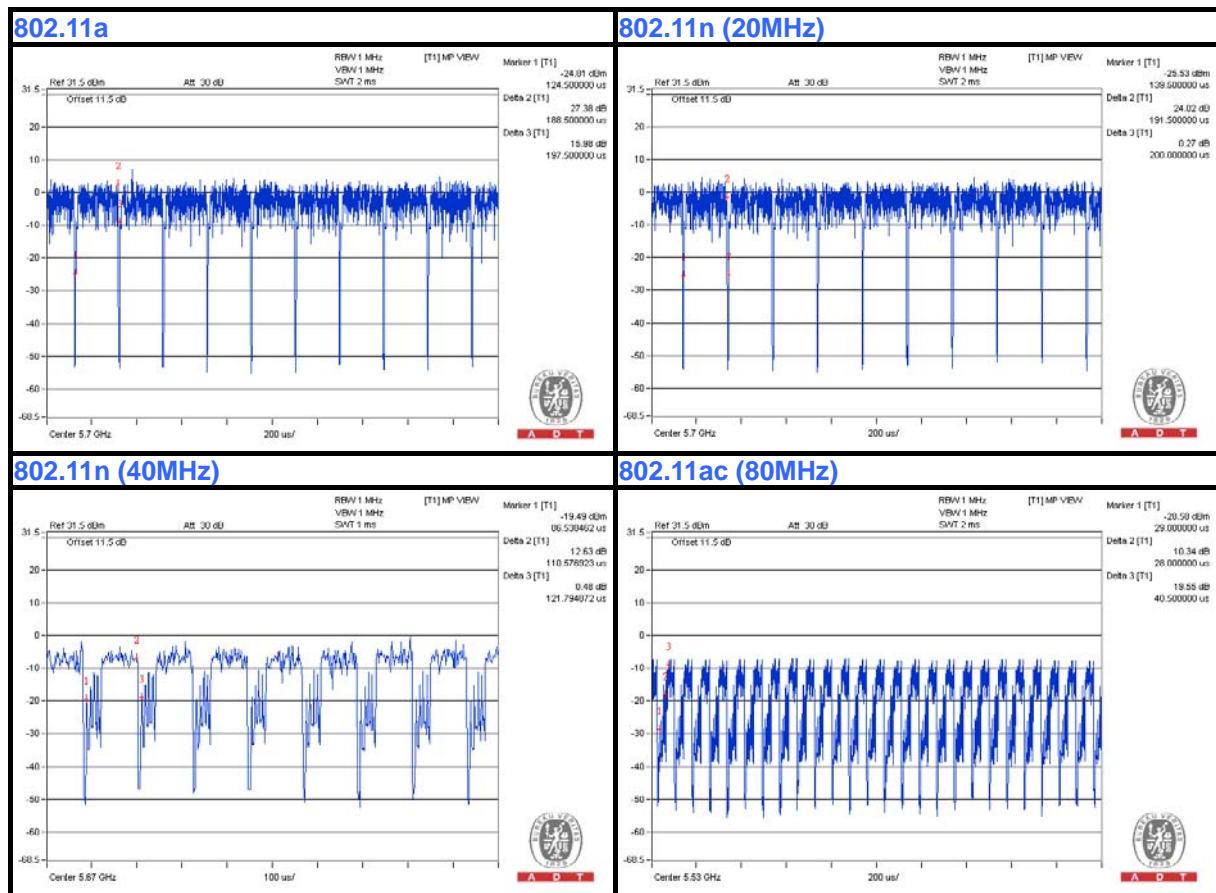

MODULATION TYPE: 256QAM

If duty cycle is < 98%, duty factor shall be considered.

802.11ac (80MHz): Duty cycle = 0.061/0.083 = 0.735, Duty factor = 10 * log(1/0.735) = 1.34

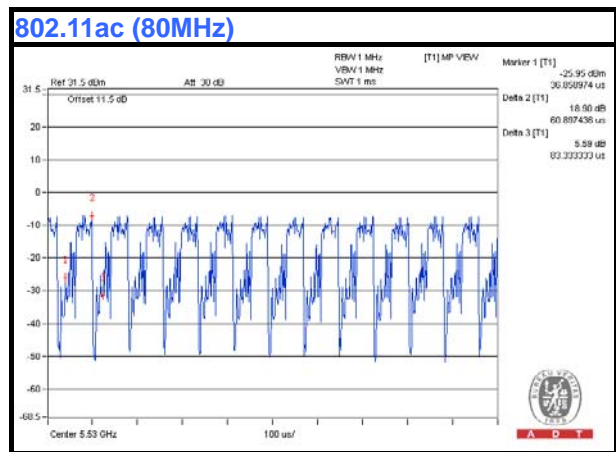

3.4 DESCRIPTION OF SUPPORT UNITS

The EUT has been tested as an independent unit together with other necessary accessories or support units. The following support units or accessories were used to form a representative test configuration during the tests.

NO.	PRODUCT	BRAND	MODEL NO.	SERIAL NO.	FCC ID
1	Notebook	DELL	E5420	BPQ7MQ1	FCC DoC Approved

NO.	SIGNAL CABLE DESCRIPTION OF THE ABOVE SUPPORT UNITS
1	0.8m USB cable

NOTE: All power cords of the above support units are non-shielded (1.8m).

3.4.1 CONFIGURATION OF SYSTEM UNDER TEST

Test Mode A

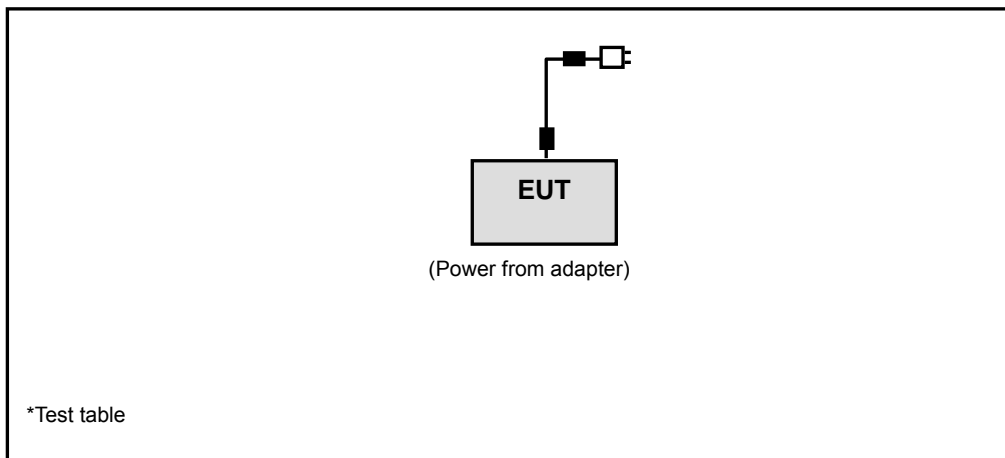



Test Mode B

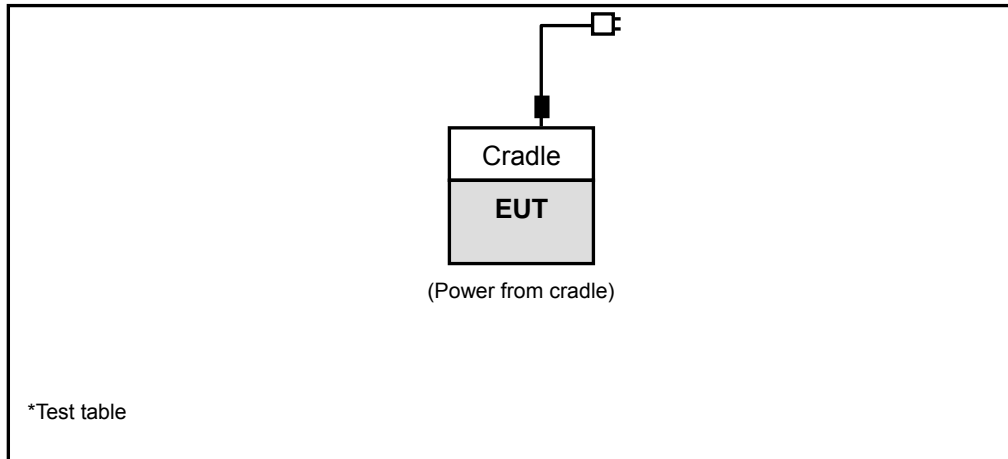

Test Mode C

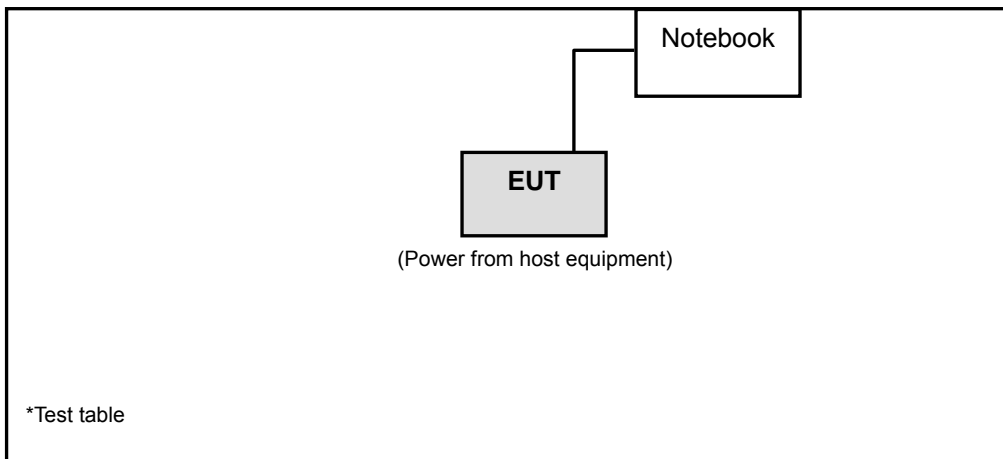

3.5 GENERAL DESCRIPTION OF APPLIED STANDARDS

The EUT is a RF Product. According to the specifications of the manufacturer, it must comply with the requirements of the following standards:

FCC Part 15, Subpart E (15.407)

789033 D01 General UNII Test Procedures v01 r03

ANSI C63.10-2009

All test items have been performed and recorded as per the above standards.

NOTE: The EUT is also considered as a kind of computer peripheral, because the connection to computer is necessary for typical use. It has been verified to comply with the requirements of FCC Part 15, Subpart B, Class B (DoC). The test report has been issued separately.

4. TEST TYPES AND RESULTS

4.1 RADIATED EMISSION AND BANDEDGE MEASUREMENT

4.1.1 LIMITS OF RADIATED EMISSION AND BANDEDGE MEASUREMENT

Radiated emissions which fall in the restricted bands must comply with the radiated emission limits specified as below table:

FREQUENCIES (MHz)	FIELD STRENGTH (microvolts/meter)	MEASUREMENT DISTANCE (meters)
0.009 ~ 0.490	2400/F(kHz)	300
0.490 ~ 1.705	24000/F(kHz)	30
1.705 ~ 30.0	30	30
30 ~ 88	100	3
88 ~ 216	150	3
216 ~ 960	200	3
Above 960	500	3

NOTE:

1. The lower limit shall apply at the transition frequencies.
2. Emission level (dBuV/m) = 20 log Emission level (uV/m).
3. For frequencies above 1000MHz, the field strength limits are based on average detector, however, the peak field strength of any emission shall not exceed the maximum permitted average limits, specified above by more than 20dB under any condition of modulation.

4.1.2 LIMITS OF UNWANTED EMISSION OUT OF THE RESTRICTED BANDS

APPLICABLE TO	LIMIT	
√	FIELD STRENGTH AT 3m (dBμV/m)	
	PK	AV
	74	54
	EIRP LIMIT (dBm)	EQUIVALENT FIELD STRENGTH AT 3m (dBμV/m)
	PK	PK
	-27	68.3

NOTE: The following formula is used to convert the equipment isotropic radiated power (eirp) to field strength:

$$E = \frac{1000000\sqrt{30P}}{3} \mu\text{V/m, where P is the eirp (Watts).}$$

4.1.3 TEST INSTRUMENTS

DESCRIPTION & MANUFACTURER	MODEL NO.	SERIAL NO.	DATE OF CALIBRATION	DUE DATE OF CALIBRATION
Test Receiver ROHDE & SCHWARZ	ESI7	838496/016	Dec. 25, 2012	Dec. 24, 2013
Spectrum Analyzer ROHDE & SCHWARZ	FSP40	100039	Jan. 31, 2013	Jan. 30, 2014
BILOG Antenna SCHWARZBECK	VULB9168	9168-160	Mar. 20, 2013	Mar. 19, 2014
HORN Antenna SCHWARZBECK	BBHA 9120D	9120D-404	Dec. 22, 2012	Dec. 21, 2013
HORN Antenna SCHWARZBECK	BBHA 9170	148	Jul. 15, 2013	Jul. 14, 2014
Preamplifier Agilent	8447D	2944A10633	Oct. 25, 2012	Oct. 24, 2013
Preamplifier Agilent	8449B	3008A01964	Oct. 25, 2012	Oct. 24, 2013
RF signal cable HUBER+SUHNNER	SUCOFLEX 104	250723/4	Aug. 23, 2013	Aug. 22, 2014
RF signal cable HUBER+SUHNNER	SUCOFLEX 106	12738/6+309224/4	Aug. 23, 2013	Aug. 22, 2014
Software BV ADT	ADT_Radiated_ V7.6.15.9.4	NA	NA	NA
Antenna Tower inn-co GmbH	MA 4000	013303	NA	NA
Antenna Tower Controller inn-co GmbH	CO2000	017303	NA	NA
Turn Table BV ADT	TT100	TT93021703	NA	NA
Turn Table Controller BV ADT	SC100	SC93021703	NA	NA
26GHz ~ 40GHz Amplifier	EM26400	815221	Oct. 25, 2012	Oct. 24, 2013
High Speed Peak Power Meter	ML2495A	0824011	Jul. 29, 2013	Jul. 28, 2014
Power Sensor	MA2411B	0738171	Jul. 29, 2013	Jul. 28, 2014
WIT Standard Temperature And Humidity Chamber	TH-4S-C	W981030	Jun. 10, 2013	Jun. 09, 2014

- NOTE:**
1. The calibration interval of the above test instruments is 12 months and the calibrations are traceable to NML/ROC and NIST/USA.
 2. The test was performed in HwaYa Chamber 3.
 3. The horn antenna and HP preamplifier (model: 8449B) are used only for the measurement of emission frequency above 1GHz if tested.
 4. The FCC Site Registration No. is 988962.
 5. The IC Site Registration No. is IC 7450F-3.

4.1.4 TEST PROCEDURES

- a. The EUT was placed on the top of a rotating table 0.8 meters above the ground at a 3 meter semi-anechoic chamber. The table was rotated 360 degrees to determine the position of the highest radiation.
- b. The EUT was set 3 meters away from the interference-receiving antenna, which was mounted on the top of a variable-height antenna tower.
- c. The antenna is a broadband antenna, and its height is varied from one meter to four meters above the ground to determine the maximum value of the field strength. Both horizontal and vertical polarizations of the antenna are set to make the measurement.
- d. For each suspected emission, the EUT was arranged to its worst case and then the antenna was tuned to heights from 1 meter to 4 meters and the rotatable table was turned from 0 degrees to 360 degrees to find the maximum reading.
- e. The test-receiver system was set to Peak Detect Function and Specified Bandwidth with Maximum Hold Mode.
- f. If the emission level of the EUT in peak mode was 10dB lower than the limit specified, then testing could be stopped and the peak values of the EUT would be reported. Otherwise the emissions that did not have 10dB margin would be re-tested one by one using peak, quasi-peak or average method as specified and then reported in a data sheet.

NOTE:

1. The resolution bandwidth and video bandwidth of test receiver/spectrum analyzer is 120kHz for Quasi-peak detection at frequency below 1GHz.
2. The resolution bandwidth of test receiver/spectrum analyzer is 1MHz and the video bandwidth is 3MHz for Peak detection at frequency above 1GHz.
3. The resolution bandwidth of test receiver/spectrum analyzer is 1MHz and the video bandwidth is 1kHz (Duty cycle < 98%) or 10Hz (Duty cycle > 98%) for Average detection (AV) at frequency above 1GHz.
4. All modes of operation were investigated and the worst-case emissions are reported.

4.1.5 DEVIATION FROM TEST STANDARD

No deviation.

4.1.6 TEST SETUP

Frequency range 30MHz~1GHz

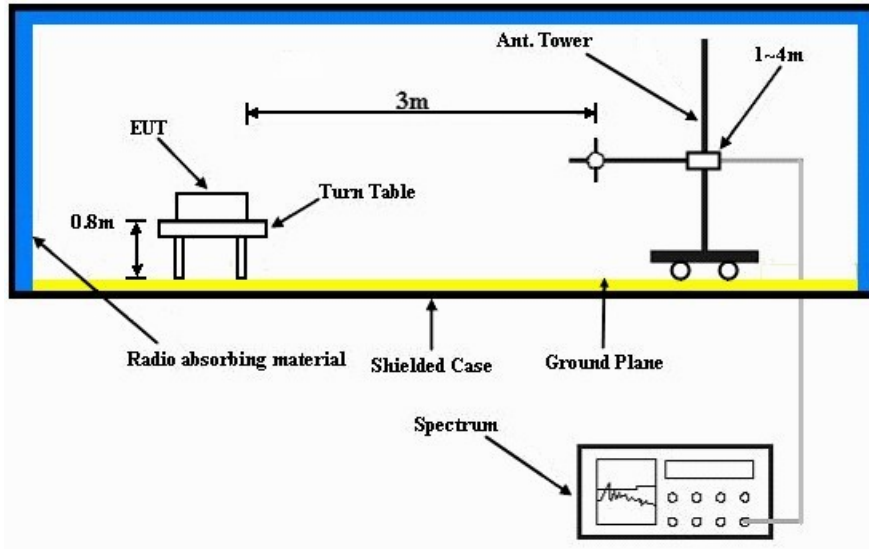

Frequency range above 1GHz

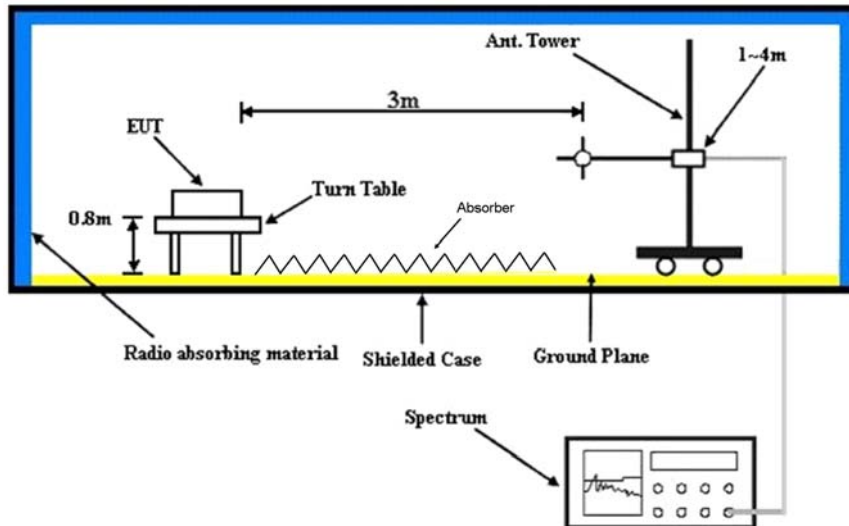

For the actual test configuration, please refer to the attached file (Test Setup Photo).

4.1.7 EUT OPERATING CONDITION

Test Mode A

- a. Set the EUT under transmission condition continuously at specific channel frequency.

Test Mode B

- a. Connected the EUT with the cradle and placed them on the test table.
- b. Set the EUT under transmission condition continuously at specific channel frequency.

Test Mode C

- a. Connected the EUT with the notebook via a USB cable.
- b. Set the EUT under charging condition.

4.1.8 TEST RESULTS

ABOVE 1GHz DATA :

802.11a

EUT TEST CONDITION		MEASUREMENT DETAIL	
CHANNEL	Channel 36	FREQUENCY RANGE	1 ~ 40GHz
INPUT POWER (SYSTEM)	120Vac, 60 Hz	DETECTOR FUNCTION	Peak (PK) Average (AV)
ENVIRONMENTAL CONDITIONS	24deg. C, 77%RH	TESTED BY	Martin Lee

ANTENNA POLARITY & TEST DISTANCE: HORIZONTAL AT 3 M								
NO.	FREQ. (MHz)	EMISSION LEVEL (dBuV/m)	LIMIT (dBuV/m)	MARGIN (dB)	ANTENNA HEIGHT (m)	TABLE ANGLE (Degree)	RAW VALUE (dBuV)	CORRECTION FACTOR (dB/m)
1	5150.00	47.6 PK	74.0	-26.4	1.10 H	132	42.50	5.10
2	5150.00	45.4 AV	54.0	-8.6	1.10 H	132	40.30	5.10
3	*5180.00	104.2 PK			1.10 H	132	66.50	37.70
4	*5180.00	93.5 AV			1.10 H	132	55.80	37.70
5	#10360.00	59.2 PK	74.0	-14.8	1.00 H	288	41.70	17.50
6	#10360.00	46.8 AV	54.0	-7.2	1.00 H	288	29.30	17.50

ANTENNA POLARITY & TEST DISTANCE: VERTICAL AT 3 M								
NO.	FREQ. (MHz)	EMISSION LEVEL (dBuV/m)	LIMIT (dBuV/m)	MARGIN (dB)	ANTENNA HEIGHT (m)	TABLE ANGLE (Degree)	RAW VALUE (dBuV)	CORRECTION FACTOR (dB/m)
1	5150.00	59.2 PK	74.0	-14.8	1.17 V	265	54.10	5.10
2	5150.00	47.7 AV	54.0	-6.3	1.17 V	265	42.60	5.10
3	*5180.00	109.2 PK			1.17 V	265	71.50	37.70
4	*5180.00	98.4 AV			1.17 V	265	60.70	37.70
5	#10360.00	59.8 PK	74.0	-14.2	1.00 V	114	42.30	17.50
6	#10360.00	47.9 AV	54.0	-6.1	1.00 V	114	30.40	17.50

REMARKS:

1. Emission Level(dBuV/m) = Raw Value(dBuV) + Correction Factor(dB/m)
2. Correction Factor(dB/m) = Antenna Factor(dB/m) + Cable Factor(dB) – Pre-Amplifier Factor(dB)
3. The other emission levels were very low against the limit.
4. Margin value = Emission Level – Limit value
5. “ * “: Fundamental frequency.
6. “#”:The radiated frequency is out the restricted band.

EUT TEST CONDITION		MEASUREMENT DETAIL	
CHANNEL	Channel 40	FREQUENCY RANGE	1 ~ 40GHz
INPUT POWER (SYSTEM)	120Vac, 60 Hz	DETECTOR FUNCTION	Peak (PK) Average (AV)
ENVIRONMENTAL CONDITIONS	24deg. C, 77%RH	TESTED BY	Martin Lee

ANTENNA POLARITY & TEST DISTANCE: HORIZONTAL AT 3 M								
NO.	FREQ. (MHz)	EMISSION LEVEL (dBuV/m)	LIMIT (dBuV/m)	MARGIN (dB)	ANTENNA HEIGHT (m)	TABLE ANGLE (Degree)	RAW VALUE (dBuV)	CORRECTION FACTOR (dB/m)
1	*5200.00	104.5 PK			1.13 H	135	66.70	37.80
2	*5200.00	94.1 AV			1.13 H	135	56.30	37.80
3	#10400.00	59.1 PK	74.0	-14.9	1.00 H	333	41.30	17.80
4	#10400.00	47.5 AV	54.0	-6.5	1.00 H	333	29.70	17.80
ANTENNA POLARITY & TEST DISTANCE: VERTICAL AT 3 M								
NO.	FREQ. (MHz)	EMISSION LEVEL (dBuV/m)	LIMIT (dBuV/m)	MARGIN (dB)	ANTENNA HEIGHT (m)	TABLE ANGLE (Degree)	RAW VALUE (dBuV)	CORRECTION FACTOR (dB/m)
1	*5200.00	109.0 PK			1.20 V	266	71.20	37.80
2	*5200.00	98.7 AV			1.20 V	266	60.90	37.80
3	#10400.00	59.9 PK	74.0	-14.1	1.00 V	257	42.10	17.80
4	#10400.00	48.6 AV	54.0	-5.4	1.00 V	257	30.80	17.80

REMARKS:

- Emission Level(dBuV/m) = Raw Value(dBuV) + Correction Factor(dB/m)
- Correction Factor(dB/m) = Antenna Factor(dB/m) + Cable Factor(dB) – Pre-Amplifier Factor(dB)
- The other emission levels were very low against the limit.
- Margin value = Emission Level – Limit value
- " * ": Fundamental frequency.
- "#":The radiated frequency is out the restricted band.



A D T

EUT TEST CONDITION		MEASUREMENT DETAIL	
CHANNEL	Channel 48	FREQUENCY RANGE	1 ~ 40GHz
INPUT POWER (SYSTEM)	120Vac, 60 Hz	DETECTOR FUNCTION	Peak (PK) Average (AV)
ENVIRONMENTAL CONDITIONS	24deg. C, 77%RH	TESTED BY	Martin Lee

ANTENNA POLARITY & TEST DISTANCE: HORIZONTAL AT 3 M								
NO.	FREQ. (MHz)	EMISSION LEVEL (dBuV/m)	LIMIT (dBuV/m)	MARGIN (dB)	ANTENNA HEIGHT (m)	TABLE ANGLE (Degree)	RAW VALUE (dBuV)	CORRECTION FACTOR (dB/m)
1	*5240.00	104.8 PK			1.12 H	240	66.90	37.90
2	*5240.00	94.5 AV			1.12 H	240	56.60	37.90
3	5350.00	56.0 PK	74.0	-18.0	1.12 H	240	50.60	5.40
4	5350.00	45.1 AV	54.0	-8.9	1.12 H	240	39.70	5.40
5	#10480.00	59.8 PK	74.0	-14.2	1.00 H	257	41.50	18.30
6	#10480.00	47.7 AV	54.0	-6.3	1.00 H	257	29.40	18.30
ANTENNA POLARITY & TEST DISTANCE: VERTICAL AT 3 M								
NO.	FREQ. (MHz)	EMISSION LEVEL (dBuV/m)	LIMIT (dBuV/m)	MARGIN (dB)	ANTENNA HEIGHT (m)	TABLE ANGLE (Degree)	RAW VALUE (dBuV)	CORRECTION FACTOR (dB/m)
1	*5240.00	108.8 PK			1.14 V	270	70.90	37.90
2	*5240.00	98.7 AV			1.14 V	270	60.80	37.90
3	5350.00	59.2 PK	74.0	-14.8	1.14 V	270	53.80	5.40
4	5350.00	47.3 AV	54.0	-6.7	1.14 V	270	41.90	5.40
5	#10480.00	60.1 PK	74.0	-13.9	1.00 V	315	41.80	18.30
6	#10480.00	48.2 AV	54.0	-5.8	1.00 V	315	29.90	18.30

REMARKS:

1. Emission Level(dBuV/m) = Raw Value(dBuV) + Correction Factor(dB/m)
2. Correction Factor(dB/m) = Antenna Factor(dB/m) + Cable Factor(dB)
– Pre-Amplifier Factor(dB)
3. The other emission levels were very low against the limit.
4. Margin value = Emission Level – Limit value
5. “ * “: Fundamental frequency.
6. “#”:The radiated frequency is out the restricted band.



A D T

EUT TEST CONDITION		MEASUREMENT DETAIL	
CHANNEL	Channel 52	FREQUENCY RANGE	1 ~ 40GHz
INPUT POWER (SYSTEM)	120Vac, 60 Hz	DETECTOR FUNCTION	Peak (PK) Average (AV)
ENVIRONMENTAL CONDITIONS	24deg. C, 77%RH	TESTED BY	Martin Lee

ANTENNA POLARITY & TEST DISTANCE: HORIZONTAL AT 3 M								
NO.	FREQ. (MHz)	EMISSION LEVEL (dBuV/m)	LIMIT (dBuV/m)	MARGIN (dB)	ANTENNA HEIGHT (m)	TABLE ANGLE (Degree)	RAW VALUE (dBuV)	CORRECTION FACTOR (dB/m)
1	5150.00	55.3 PK	74.0	-18.7	1.11 H	290	50.20	5.10
2	5150.00	44.8 AV	54.0	-9.2	1.11 H	290	39.70	5.10
3	*5260.00	104.3 PK			1.11 H	290	66.40	37.90
4	*5260.00	93.8 AV			1.11 H	290	55.90	37.90
5	#10520.00	57.8 PK	74.0	-16.2	1.00 H	308	39.70	18.10
6	#10520.00	46.5 AV	54.0	-7.5	1.00 H	308	28.40	18.10
ANTENNA POLARITY & TEST DISTANCE: VERTICAL AT 3 M								
NO.	FREQ. (MHz)	EMISSION LEVEL (dBuV/m)	LIMIT (dBuV/m)	MARGIN (dB)	ANTENNA HEIGHT (m)	TABLE ANGLE (Degree)	RAW VALUE (dBuV)	CORRECTION FACTOR (dB/m)
1	5150.00	56.8 PK	74.0	-17.2	1.26 V	266	51.70	5.10
2	5150.00	46.4 AV	54.0	-7.6	1.26 V	266	41.30	5.10
3	*5260.00	107.7 PK			1.26 V	266	69.80	37.90
4	*5260.00	97.6 AV			1.26 V	266	59.70	37.90
5	#10520.00	58.3 PK	74.0	-15.7	1.00 V	118	40.20	18.10
6	#10520.00	47.6 AV	54.0	-6.4	1.00 V	118	29.50	18.10

REMARKS:

1. Emission Level(dBuV/m) = Raw Value(dBuV) + Correction Factor(dB/m)
2. Correction Factor(dB/m) = Antenna Factor(dB/m) + Cable Factor(dB)
– Pre-Amplifier Factor(dB)
3. The other emission levels were very low against the limit.
4. Margin value = Emission Level – Limit value
5. “ * “: Fundamental frequency.
6. “#“:The radiated frequency is out the restricted band.



A D T

EUT TEST CONDITION		MEASUREMENT DETAIL	
CHANNEL	Channel 60	FREQUENCY RANGE	1 ~ 40GHz
INPUT POWER (SYSTEM)	120Vac, 60 Hz	DETECTOR FUNCTION	Peak (PK) Average (AV)
ENVIRONMENTAL CONDITIONS	24deg. C, 77%RH	TESTED BY	Martin Lee

ANTENNA POLARITY & TEST DISTANCE: HORIZONTAL AT 3 M								
NO.	FREQ. (MHz)	EMISSION LEVEL (dBuV/m)	LIMIT (dBuV/m)	MARGIN (dB)	ANTENNA HEIGHT (m)	TABLE ANGLE (Degree)	RAW VALUE (dBuV)	CORRECTION FACTOR (dB/m)
1	*5300.00	106.1 PK			1.23 H	274	68.20	37.90
2	*5300.00	95.1 AV			1.23 H	274	57.20	37.90
3	10600.00	58.4 PK	74.0	-15.6	1.00 H	269	40.80	17.60
4	10600.00	47.0 AV	54.0	-7.0	1.00 H	269	29.40	17.60
ANTENNA POLARITY & TEST DISTANCE: VERTICAL AT 3 M								
NO.	FREQ. (MHz)	EMISSION LEVEL (dBuV/m)	LIMIT (dBuV/m)	MARGIN (dB)	ANTENNA HEIGHT (m)	TABLE ANGLE (Degree)	RAW VALUE (dBuV)	CORRECTION FACTOR (dB/m)
1	*5300.00	107.9 PK			1.23 V	269	70.00	37.90
2	*5300.00	97.6 AV			1.23 V	269	59.70	37.90
3	10600.00	58.6 PK	74.0	-15.4	1.00 V	182	41.00	17.60
4	10600.00	47.4 AV	54.0	-6.6	1.00 V	182	29.80	17.60

REMARKS:

1. Emission Level(dBuV/m) = Raw Value(dBuV) + Correction Factor(dB/m)
2. Correction Factor(dB/m) = Antenna Factor(dB/m) + Cable Factor(dB) – Pre-Amplifier Factor(dB)
3. The other emission levels were very low against the limit.
4. Margin value = Emission Level – Limit value
5. “ * “: Fundamental frequency.



A D T

EUT TEST CONDITION		MEASUREMENT DETAIL	
CHANNEL	Channel 64	FREQUENCY RANGE	1 ~ 40GHz
INPUT POWER (SYSTEM)	120Vac, 60 Hz	DETECTOR FUNCTION	Peak (PK) Average (AV)
ENVIRONMENTAL CONDITIONS	24deg. C, 77%RH	TESTED BY	Martin Lee

ANTENNA POLARITY & TEST DISTANCE: HORIZONTAL AT 3 M								
NO.	FREQ. (MHz)	EMISSION LEVEL (dBuV/m)	LIMIT (dBuV/m)	MARGIN (dB)	ANTENNA HEIGHT (m)	TABLE ANGLE (Degree)	RAW VALUE (dBuV)	CORRECTION FACTOR (dB/m)
1	*5320.00	106.4 PK			1.10 H	292	68.40	38.00
2	*5320.00	95.4 AV			1.10 H	292	57.40	38.00
3	5372.00	56.6 PK	74.0	-17.4	1.10 H	292	51.20	5.40
4	5372.00	45.4 AV	54.0	-8.6	1.10 H	292	40.00	5.40
5	10640.00	58.7 PK	74.0	-15.3	1.00 H	208	41.30	17.40
6	10640.00	46.5 AV	54.0	-7.5	1.00 H	208	29.10	17.40
ANTENNA POLARITY & TEST DISTANCE: VERTICAL AT 3 M								
NO.	FREQ. (MHz)	EMISSION LEVEL (dBuV/m)	LIMIT (dBuV/m)	MARGIN (dB)	ANTENNA HEIGHT (m)	TABLE ANGLE (Degree)	RAW VALUE (dBuV)	CORRECTION FACTOR (dB/m)
1	*5320.00	108.2 PK			1.23 V	266	70.20	38.00
2	*5320.00	97.5 AV			1.23 V	266	59.50	38.00
3	5372.00	59.1 PK	74.0	-14.9	1.21 V	266	53.70	5.40
4	5372.00	46.8 AV	54.0	-7.2	1.21 V	266	41.40	5.40
5	10640.00	59.5 PK	74.0	-14.5	1.00 V	168	42.10	17.40
6	10640.00	47.0 AV	54.0	-7.0	1.00 V	168	29.60	17.40

REMARKS:

1. Emission Level(dBuV/m) = Raw Value(dBuV) + Correction Factor(dB/m)
2. Correction Factor(dB/m) = Antenna Factor(dB/m) + Cable Factor(dB)
– Pre-Amplifier Factor(dB)
3. The other emission levels were very low against the limit.
4. Margin value = Emission Level – Limit value
5. “ * “: Fundamental frequency.



A D T

EUT TEST CONDITION		MEASUREMENT DETAIL	
CHANNEL	Channel 100	FREQUENCY RANGE	1 ~ 40GHz
INPUT POWER (SYSTEM)	120Vac, 60 Hz	DETECTOR FUNCTION	Peak (PK) Average (AV)
ENVIRONMENTAL CONDITIONS	24deg. C, 77%RH	TESTED BY	Martin Lee

ANTENNA POLARITY & TEST DISTANCE: HORIZONTAL AT 3 M								
NO.	FREQ. (MHz)	EMISSION LEVEL (dBuV/m)	LIMIT (dBuV/m)	MARGIN (dB)	ANTENNA HEIGHT (m)	TABLE ANGLE (Degree)	RAW VALUE (dBuV)	CORRECTION FACTOR (dB/m)
1	5460.00	55.6 PK	74.0	-18.4	1.18 H	13	50.00	5.60
2	5460.00	44.2 AV	54.0	-9.8	1.18 H	13	38.60	5.60
3	#5470.00	57.6 PK	74.0	-16.4	1.18 H	103	51.90	5.70
4	#5470.00	46.3 AV	54.0	-7.7	1.18 H	103	40.60	5.70
5	*5500.00	107.0 PK			1.18 H	103	68.70	38.30
6	*5500.00	95.9 AV			1.18 H	103	57.60	38.30
7	11000.00	58.1 PK	74.0	-15.9	1.00 H	177	39.90	18.20
8	11000.00	47.5 AV	54.0	-6.5	1.00 H	177	29.30	18.20
ANTENNA POLARITY & TEST DISTANCE: VERTICAL AT 3 M								
NO.	FREQ. (MHz)	EMISSION LEVEL (dBuV/m)	LIMIT (dBuV/m)	MARGIN (dB)	ANTENNA HEIGHT (m)	TABLE ANGLE (Degree)	RAW VALUE (dBuV)	CORRECTION FACTOR (dB/m)
1	5460.00	57.7 PK	74.0	-16.3	1.09 V	273	52.10	5.60
2	5460.00	44.1 AV	54.0	-9.9	1.09 V	273	38.50	5.60
3	#5470.00	58.8 PK	74.0	-15.2	1.09 V	273	53.10	5.70
4	#5470.00	46.6 AV	54.0	-7.4	1.09 V	273	40.90	5.70
5	*5500.00	108.5 PK			1.09 V	273	70.20	38.30
6	*5500.00	98.4 AV			1.09 V	273	60.10	38.30
7	11000.00	58.2 PK	74.0	-15.8	1.00 V	99	40.00	18.20
8	11000.00	48.0 AV	54.0	-6.0	1.00 V	99	29.80	18.20

REMARKS:

1. Emission Level(dBuV/m) = Raw Value(dBuV) + Correction Factor(dB/m)
2. Correction Factor(dB/m) = Antenna Factor(dB/m) + Cable Factor(dB) – Pre-Amplifier Factor(dB)
3. The other emission levels were very low against the limit.
4. Margin value = Emission Level – Limit value
5. “ * “: Fundamental frequency.
6. "#":The radiated frequency is out the restricted band.



A D T

EUT TEST CONDITION		MEASUREMENT DETAIL	
CHANNEL	Channel 116	FREQUENCY RANGE	1 ~ 40GHz
INPUT POWER (SYSTEM)	120Vac, 60 Hz	DETECTOR FUNCTION	Peak (PK) Average (AV)
ENVIRONMENTAL CONDITIONS	24deg. C, 77%RH	TESTED BY	Martin Lee

ANTENNA POLARITY & TEST DISTANCE: HORIZONTAL AT 3 M								
NO.	FREQ. (MHz)	EMISSION LEVEL (dBuV/m)	LIMIT (dBuV/m)	MARGIN (dB)	ANTENNA HEIGHT (m)	TABLE ANGLE (Degree)	RAW VALUE (dBuV)	CORRECTION FACTOR (dB/m)
1	*5580.00	106.4 PK			1.17 H	300	68.10	38.30
2	*5580.00	96.3 AV			1.17 H	300	58.00	38.30
3	11160.00	58.6 PK	74.0	-15.4	1.00 H	209	40.30	18.30
4	11160.00	46.7 AV	54.0	-7.3	1.00 H	209	28.40	18.30
ANTENNA POLARITY & TEST DISTANCE: VERTICAL AT 3 M								
NO.	FREQ. (MHz)	EMISSION LEVEL (dBuV/m)	LIMIT (dBuV/m)	MARGIN (dB)	ANTENNA HEIGHT (m)	TABLE ANGLE (Degree)	RAW VALUE (dBuV)	CORRECTION FACTOR (dB/m)
1	*5580.00	108.3 PK			1.22 V	267	70.00	38.30
2	*5580.00	98.3 AV			1.22 V	267	60.00	38.30
3	11160.00	59.1 PK	74.0	-14.9	1.00 V	160	40.80	18.30
4	11160.00	47.8 AV	54.0	-6.2	1.00 V	160	29.50	18.30

REMARKS:

1. Emission Level(dBuV/m) = Raw Value(dBuV) + Correction Factor(dB/m)
2. Correction Factor(dB/m) = Antenna Factor(dB/m) + Cable Factor(dB) – Pre-Amplifier Factor(dB)
3. The other emission levels were very low against the limit.
4. Margin value = Emission Level – Limit value
5. “ * “: Fundamental frequency.



A D T

EUT TEST CONDITION		MEASUREMENT DETAIL	
CHANNEL	Channel 140	FREQUENCY RANGE	1 ~ 40GHz
INPUT POWER (SYSTEM)	120Vac, 60 Hz	DETECTOR FUNCTION	Peak (PK) Average (AV)
ENVIRONMENTAL CONDITIONS	24deg. C, 77%RH	TESTED BY	Martin Lee

ANTENNA POLARITY & TEST DISTANCE: HORIZONTAL AT 3 M								
NO.	FREQ. (MHz)	EMISSION LEVEL (dBuV/m)	LIMIT (dBuV/m)	MARGIN (dB)	ANTENNA HEIGHT (m)	TABLE ANGLE (Degree)	RAW VALUE (dBuV)	CORRECTION FACTOR (dB/m)
1	*5700.00	107.0 PK			1.11 H	135	68.50	38.50
2	*5700.00	96.5 AV			1.11 H	135	58.00	38.50
3	#5725.00	58.9 PK	74.0	-15.1	1.11 H	135	52.90	6.00
4	#5725.00	44.0 AV	54.0	-10.0	1.11 H	135	38.00	6.00
5	11400.00	59.0 PK	74.0	-15.0	1.00 H	144	40.20	18.80
6	11400.00	48.0 AV	54.0	-6.0	1.00 H	144	29.20	18.80
ANTENNA POLARITY & TEST DISTANCE: VERTICAL AT 3 M								
NO.	FREQ. (MHz)	EMISSION LEVEL (dBuV/m)	LIMIT (dBuV/m)	MARGIN (dB)	ANTENNA HEIGHT (m)	TABLE ANGLE (Degree)	RAW VALUE (dBuV)	CORRECTION FACTOR (dB/m)
1	*5700.00	109.3 PK			1.06 V	274	70.80	38.50
2	*5700.00	97.6 AV			1.06 V	274	59.10	38.50
3	#5725.00	61.9 PK	74.0	-12.1	1.06 V	274	55.90	6.00
4	#5725.00	45.0 AV	54.0	-9.0	1.06 V	274	39.00	6.00
5	11400.00	59.5 PK	74.0	-14.5	1.00 V	288	40.70	18.80
6	11400.00	48.6 AV	54.0	-5.4	1.00 V	288	29.80	18.80

REMARKS:

1. Emission Level(dBuV/m) = Raw Value(dBuV) + Correction Factor(dB/m)
2. Correction Factor(dB/m) = Antenna Factor(dB/m) + Cable Factor(dB)
– Pre-Amplifier Factor(dB)
3. The other emission levels were very low against the limit.
4. Margin value = Emission Level – Limit value
5. “ * “: Fundamental frequency.
6. “#“:The radiated frequency is out the restricted band.

802.11n (20MHz)

EUT TEST CONDITION		MEASUREMENT DETAIL	
CHANNEL	Channel 36	FREQUENCY RANGE	1 ~ 40GHz
INPUT POWER (SYSTEM)	120Vac, 60 Hz	DETECTOR FUNCTION	Peak (PK) Average (AV)
ENVIRONMENTAL CONDITIONS	24deg. C, 77%RH	TESTED BY	Martin Lee

ANTENNA POLARITY & TEST DISTANCE: HORIZONTAL AT 3 M								
NO.	FREQ. (MHz)	EMISSION LEVEL (dBuV/m)	LIMIT (dBuV/m)	MARGIN (dB)	ANTENNA HEIGHT (m)	TABLE ANGLE (Degree)	RAW VALUE (dBuV)	CORRECTION FACTOR (dB/m)
1	5150.00	56.3 PK	74.0	-17.7	1.15 H	64	51.20	5.10
2	5150.00	44.9 AV	54.0	-9.1	1.15 H	64	39.80	5.10
3	*5180.00	103.0 PK			1.15 H	64	65.30	37.70
4	*5180.00	92.2 AV			1.15 H	64	54.50	37.70
5	#10360.00	59.2 PK	74.0	-14.8	1.00 H	252	41.70	17.50
6	#10360.00	46.6 AV	54.0	-7.4	1.00 H	252	29.10	17.50
ANTENNA POLARITY & TEST DISTANCE: VERTICAL AT 3 M								
NO.	FREQ. (MHz)	EMISSION LEVEL (dBuV/m)	LIMIT (dBuV/m)	MARGIN (dB)	ANTENNA HEIGHT (m)	TABLE ANGLE (Degree)	RAW VALUE (dBuV)	CORRECTION FACTOR (dB/m)
1	5150.00	56.9 PK	74.0	-17.1	1.17 V	266	51.80	5.10
2	5150.00	46.4 AV	54.0	-7.6	1.17 V	266	41.30	5.10
3	*5180.00	106.0 PK			1.17 V	266	68.30	37.70
4	*5180.00	95.7 AV			1.17 V	266	58.00	37.70
5	#10360.00	59.9 PK	74.0	-14.1	1.00 V	55	42.40	17.50
6	#10360.00	47.4 AV	54.0	-6.6	1.00 V	55	29.90	17.50

REMARKS:

1. Emission Level(dBuV/m) = Raw Value(dBuV) + Correction Factor(dB/m)
2. Correction Factor(dB/m) = Antenna Factor(dB/m) + Cable Factor(dB)
– Pre-Amplifier Factor(dB)
3. The other emission levels were very low against the limit.
4. Margin value = Emission Level – Limit value
5. “ * “: Fundamental frequency.
6. “#”:The radiated frequency is out the restricted band.



A D T

EUT TEST CONDITION		MEASUREMENT DETAIL	
CHANNEL	Channel 40	FREQUENCY RANGE	1 ~ 40GHz
INPUT POWER (SYSTEM)	120Vac, 60 Hz	DETECTOR FUNCTION	Peak (PK) Average (AV)
ENVIRONMENTAL CONDITIONS	24deg. C, 77%RH	TESTED BY	Martin Lee

ANTENNA POLARITY & TEST DISTANCE: HORIZONTAL AT 3 M								
NO.	FREQ. (MHz)	EMISSION LEVEL (dBuV/m)	LIMIT (dBuV/m)	MARGIN (dB)	ANTENNA HEIGHT (m)	TABLE ANGLE (Degree)	RAW VALUE (dBuV)	CORRECTION FACTOR (dB/m)
1	*5200.00	103.3 PK			1.17 H	65	65.50	37.80
2	*5200.00	92.4 AV			1.17 H	65	54.60	37.80
3	#10400.00	59.4 PK	74.0	-14.6	1.47 H	215	41.60	17.80
4	#10400.00	46.6 AV	54.0	-7.4	1.47 H	215	28.80	17.80
ANTENNA POLARITY & TEST DISTANCE: VERTICAL AT 3 M								
NO.	FREQ. (MHz)	EMISSION LEVEL (dBuV/m)	LIMIT (dBuV/m)	MARGIN (dB)	ANTENNA HEIGHT (m)	TABLE ANGLE (Degree)	RAW VALUE (dBuV)	CORRECTION FACTOR (dB/m)
1	*5200.00	106.3 PK			1.18 V	265	68.50	37.80
2	*5200.00	96.0 AV			1.18 V	265	58.20	37.80
3	#10400.00	59.6 PK	74.0	-14.4	1.35 V	52	41.80	17.80
4	#10400.00	47.0 AV	54.0	-7.0	1.35 V	52	29.20	17.80

REMARKS:

1. Emission Level(dBuV/m) = Raw Value(dBuV) + Correction Factor(dB/m)
2. Correction Factor(dB/m) = Antenna Factor(dB/m) + Cable Factor(dB) – Pre-Amplifier Factor(dB)
3. The other emission levels were very low against the limit.
4. Margin value = Emission Level – Limit value
5. “ * “: Fundamental frequency.
6. "#":The radiated frequency is out the restricted band.



A D T

EUT TEST CONDITION		MEASUREMENT DETAIL	
CHANNEL	Channel 48	FREQUENCY RANGE	1 ~ 40GHz
INPUT POWER (SYSTEM)	120Vac, 60 Hz	DETECTOR FUNCTION	Peak (PK) Average (AV)
ENVIRONMENTAL CONDITIONS	24deg. C, 77%RH	TESTED BY	Martin Lee

ANTENNA POLARITY & TEST DISTANCE: HORIZONTAL AT 3 M								
NO.	FREQ. (MHz)	EMISSION LEVEL (dBuV/m)	LIMIT (dBuV/m)	MARGIN (dB)	ANTENNA HEIGHT (m)	TABLE ANGLE (Degree)	RAW VALUE (dBuV)	CORRECTION FACTOR (dB/m)
1	*5240.00	103.4 PK			1.10 H	72	65.50	37.90
2	*5240.00	92.6 AV			1.10 H	72	54.70	37.90
3	5350.00	55.5 PK	74.0	-18.5	1.10 H	72	50.10	5.40
4	5350.00	45.4 AV	54.0	-8.6	1.10 H	72	40.00	5.40
5	#10480.00	58.6 PK	74.0	-15.4	1.00 H	196	40.30	18.30
6	#10480.00	46.7 AV	54.0	-7.3	1.00 H	196	28.40	18.30
ANTENNA POLARITY & TEST DISTANCE: VERTICAL AT 3 M								
NO.	FREQ. (MHz)	EMISSION LEVEL (dBuV/m)	LIMIT (dBuV/m)	MARGIN (dB)	ANTENNA HEIGHT (m)	TABLE ANGLE (Degree)	RAW VALUE (dBuV)	CORRECTION FACTOR (dB/m)
1	*5240.00	106.9 PK			1.20 V	265	69.00	37.90
2	*5240.00	96.1 AV			1.20 V	265	58.20	37.90
3	5350.00	58.6 PK	74.0	-15.4	1.20 V	265	53.20	5.40
4	5350.00	46.5 AV	54.0	-7.5	1.20 V	265	41.10	5.40
5	#10480.00	59.5 PK	74.0	-14.5	1.00 V	291	41.20	18.30
6	#10480.00	47.9 AV	54.0	-6.1	1.00 V	291	29.60	18.30

REMARKS:

1. Emission Level(dBuV/m) = Raw Value(dBuV) + Correction Factor(dB/m)
2. Correction Factor(dB/m) = Antenna Factor(dB/m) + Cable Factor(dB)
– Pre-Amplifier Factor(dB)
3. The other emission levels were very low against the limit.
4. Margin value = Emission Level – Limit value
5. “ * “: Fundamental frequency.
6. “#“:The radiated frequency is out the restricted band.



A D T

EUT TEST CONDITION		MEASUREMENT DETAIL	
CHANNEL	Channel 52	FREQUENCY RANGE	1 ~ 40GHz
INPUT POWER (SYSTEM)	120Vac, 60 Hz	DETECTOR FUNCTION	Peak (PK) Average (AV)
ENVIRONMENTAL CONDITIONS	24deg. C, 77%RH	TESTED BY	Martin Lee

ANTENNA POLARITY & TEST DISTANCE: HORIZONTAL AT 3 M								
NO.	FREQ. (MHz)	EMISSION LEVEL (dBuV/m)	LIMIT (dBuV/m)	MARGIN (dB)	ANTENNA HEIGHT (m)	TABLE ANGLE (Degree)	RAW VALUE (dBuV)	CORRECTION FACTOR (dB/m)
1	5150.00	56.3 PK	74.0	-17.7	1.10 H	109	51.20	5.10
2	5150.00	46.0 AV	54.0	-8.0	1.10 H	109	40.90	5.10
3	*5260.00	104.4 PK			1.10 H	109	66.50	37.90
4	*5260.00	93.9 AV			1.10 H	109	56.00	37.90
5	#10520.00	58.7 PK	74.0	-15.3	1.22 H	264	40.60	18.10
6	#10520.00	47.2 AV	54.0	-6.8	1.22 H	264	29.10	18.10
ANTENNA POLARITY & TEST DISTANCE: VERTICAL AT 3 M								
NO.	FREQ. (MHz)	EMISSION LEVEL (dBuV/m)	LIMIT (dBuV/m)	MARGIN (dB)	ANTENNA HEIGHT (m)	TABLE ANGLE (Degree)	RAW VALUE (dBuV)	CORRECTION FACTOR (dB/m)
1	5150.00	56.6 PK	74.0	-17.4	1.21 V	272	51.50	5.10
2	5150.00	46.7 AV	54.0	-7.3	1.21 V	272	41.60	5.10
3	*5260.00	108.2 PK			1.21 V	272	70.30	37.90
4	*5260.00	97.7 AV			1.21 V	272	59.80	37.90
5	#10520.00	59.5 PK	74.0	-14.5	1.00 V	149	41.40	18.10
6	#10520.00	47.7 AV	54.0	-6.3	1.00 V	149	29.60	18.10

REMARKS:

1. Emission Level(dBuV/m) = Raw Value(dBuV) + Correction Factor(dB/m)
2. Correction Factor(dB/m) = Antenna Factor(dB/m) + Cable Factor(dB)
– Pre-Amplifier Factor(dB)
3. The other emission levels were very low against the limit.
4. Margin value = Emission Level – Limit value
5. “ * “: Fundamental frequency.
6. “#“:The radiated frequency is out the restricted band.



A D T

EUT TEST CONDITION		MEASUREMENT DETAIL	
CHANNEL	Channel 60	FREQUENCY RANGE	1 ~ 40GHz
INPUT POWER (SYSTEM)	120Vac, 60 Hz	DETECTOR FUNCTION	Peak (PK) Average (AV)
ENVIRONMENTAL CONDITIONS	24deg. C, 77%RH	TESTED BY	Martin Lee

ANTENNA POLARITY & TEST DISTANCE: HORIZONTAL AT 3 M								
NO.	FREQ. (MHz)	EMISSION LEVEL (dBuV/m)	LIMIT (dBuV/m)	MARGIN (dB)	ANTENNA HEIGHT (m)	TABLE ANGLE (Degree)	RAW VALUE (dBuV)	CORRECTION FACTOR (dB/m)
1	*5300.00	104.5 PK			1.09 H	101	66.60	37.90
2	*5300.00	93.9 AV			1.09 H	101	56.00	37.90
3	10600.00	58.2 PK	74.0	-15.8	1.00 H	229	40.60	17.60
4	10600.00	46.3 AV	54.0	-7.7	1.00 H	229	28.70	17.60
ANTENNA POLARITY & TEST DISTANCE: VERTICAL AT 3 M								
NO.	FREQ. (MHz)	EMISSION LEVEL (dBuV/m)	LIMIT (dBuV/m)	MARGIN (dB)	ANTENNA HEIGHT (m)	TABLE ANGLE (Degree)	RAW VALUE (dBuV)	CORRECTION FACTOR (dB/m)
1	*5300.00	108.2 PK			1.19 V	269	70.30	37.90
2	*5300.00	97.7 AV			1.19 V	269	59.80	37.90
3	10600.00	58.8 PK	74.0	-15.2	1.00 V	289	41.20	17.60
4	10600.00	46.8 AV	54.0	-7.2	1.00 V	289	29.20	17.60

REMARKS:

- Emission Level(dBuV/m) = Raw Value(dBuV) + Correction Factor(dB/m)
- Correction Factor(dB/m) = Antenna Factor(dB/m) + Cable Factor(dB) – Pre-Amplifier Factor(dB)
- The other emission levels were very low against the limit.
- Margin value = Emission Level – Limit value
- * *: Fundamental frequency.



A D T

EUT TEST CONDITION		MEASUREMENT DETAIL	
CHANNEL	Channel 64	FREQUENCY RANGE	1 ~ 40GHz
INPUT POWER (SYSTEM)	120Vac, 60 Hz	DETECTOR FUNCTION	Peak (PK) Average (AV)
ENVIRONMENTAL CONDITIONS	24deg. C, 77%RH	TESTED BY	Martin Lee

ANTENNA POLARITY & TEST DISTANCE: HORIZONTAL AT 3 M								
NO.	FREQ. (MHz)	EMISSION LEVEL (dBuV/m)	LIMIT (dBuV/m)	MARGIN (dB)	ANTENNA HEIGHT (m)	TABLE ANGLE (Degree)	RAW VALUE (dBuV)	CORRECTION FACTOR (dB/m)
1	*5320.00	104.8 PK			1.11 H	104	66.80	38.00
2	*5320.00	94.4 AV			1.11 H	104	56.40	38.00
3	5350.00	56.9 PK	74.0	-17.1	1.11 H	104	51.50	5.40
4	5350.00	46.2 AV	54.0	-7.8	1.11 H	104	40.80	5.40
5	10640.00	58.3 PK	74.0	-15.7	1.10 H	63	40.90	17.40
6	10640.00	46.5 AV	54.0	-7.5	1.10 H	63	29.10	17.40
ANTENNA POLARITY & TEST DISTANCE: VERTICAL AT 3 M								
NO.	FREQ. (MHz)	EMISSION LEVEL (dBuV/m)	LIMIT (dBuV/m)	MARGIN (dB)	ANTENNA HEIGHT (m)	TABLE ANGLE (Degree)	RAW VALUE (dBuV)	CORRECTION FACTOR (dB/m)
1	*5320.00	108.0 PK			1.13 V	268	70.00	38.00
2	*5320.00	97.5 AV			1.13 V	268	59.50	38.00
3	5350.00	57.6 PK	74.0	-16.4	1.13 V	268	52.20	5.40
4	5350.00	47.6 AV	54.0	-6.4	1.13 V	268	42.20	5.40
5	10640.00	59.0 PK	74.0	-15.0	1.00 V	139	41.60	17.40
6	10640.00	47.2 AV	54.0	-6.8	1.00 V	139	29.80	17.40

REMARKS:

1. Emission Level(dBuV/m) = Raw Value(dBuV) + Correction Factor(dB/m)
2. Correction Factor(dB/m) = Antenna Factor(dB/m) + Cable Factor(dB)
– Pre-Amplifier Factor(dB)
3. The other emission levels were very low against the limit.
4. Margin value = Emission Level – Limit value
5. “ * “: Fundamental frequency.



A D T

EUT TEST CONDITION		MEASUREMENT DETAIL	
CHANNEL	Channel 100	FREQUENCY RANGE	1 ~ 40GHz
INPUT POWER (SYSTEM)	120Vac, 60 Hz	DETECTOR FUNCTION	Peak (PK) Average (AV)
ENVIRONMENTAL CONDITIONS	24deg. C, 77%RH	TESTED BY	Martin Lee

ANTENNA POLARITY & TEST DISTANCE: HORIZONTAL AT 3 M								
NO.	FREQ. (MHz)	EMISSION LEVEL (dBuV/m)	LIMIT (dBuV/m)	MARGIN (dB)	ANTENNA HEIGHT (m)	TABLE ANGLE (Degree)	RAW VALUE (dBuV)	CORRECTION FACTOR (dB/m)
1	5460.00	56.9 PK	74.0	-17.1	1.00 H	298	51.30	5.60
2	5460.00	44.1 AV	54.0	-9.9	1.00 H	298	38.50	5.60
3	#5470.00	57.6 PK	74.0	-16.4	1.00 H	298	51.90	5.70
4	#5470.00	45.4 AV	54.0	-8.6	1.00 H	298	39.70	5.70
5	*5500.00	103.3 PK			1.00 H	298	65.00	38.30
6	*5500.00	93.3 AV			1.00 H	298	55.00	38.30
7	11000.00	58.7 PK	74.0	-15.3	1.10 H	157	40.50	18.20
8	11000.00	47.2 AV	54.0	-6.8	1.10 H	157	29.00	18.20

ANTENNA POLARITY & TEST DISTANCE: VERTICAL AT 3 M								
NO.	FREQ. (MHz)	EMISSION LEVEL (dBuV/m)	LIMIT (dBuV/m)	MARGIN (dB)	ANTENNA HEIGHT (m)	TABLE ANGLE (Degree)	RAW VALUE (dBuV)	CORRECTION FACTOR (dB/m)
1	5460.00	55.8 PK	74.0	-18.2	1.20 V	270	50.20	5.60
2	5460.00	44.4 AV	54.0	-9.6	1.20 V	270	38.80	5.60
3	#5470.00	57.9 PK	74.0	-16.1	1.20 V	270	52.20	5.70
4	#5470.00	47.3 AV	54.0	-6.7	1.20 V	270	41.60	5.70
5	*5500.00	108.5 PK			1.20 V	270	70.20	38.30
6	*5500.00	97.4 AV			1.20 V	270	59.10	38.30
7	11000.00	59.4 PK	74.0	-14.6	1.00 V	193	41.20	18.20
8	11000.00	47.5 AV	54.0	-6.5	1.00 V	193	29.30	18.20

REMARKS:

1. Emission Level(dBuV/m) = Raw Value(dBuV) + Correction Factor(dB/m)
2. Correction Factor(dB/m) = Antenna Factor(dB/m) + Cable Factor(dB) – Pre-Amplifier Factor(dB)
3. The other emission levels were very low against the limit.
4. Margin value = Emission Level – Limit value
5. “ * “: Fundamental frequency.
6. "#":The radiated frequency is out the restricted band.

EUT TEST CONDITION		MEASUREMENT DETAIL	
CHANNEL	Channel 116	FREQUENCY RANGE	1 ~ 40GHz
INPUT POWER (SYSTEM)	120Vac, 60 Hz	DETECTOR FUNCTION	Peak (PK) Average (AV)
ENVIRONMENTAL CONDITIONS	24deg. C, 77%RH	TESTED BY	Martin Lee

ANTENNA POLARITY & TEST DISTANCE: HORIZONTAL AT 3 M								
NO.	FREQ. (MHz)	EMISSION LEVEL (dBuV/m)	LIMIT (dBuV/m)	MARGIN (dB)	ANTENNA HEIGHT (m)	TABLE ANGLE (Degree)	RAW VALUE (dBuV)	CORRECTION FACTOR (dB/m)
1	*5580.00	104.9 PK			1.00 H	299	66.60	38.30
2	*5580.00	94.3 AV			1.00 H	299	56.00	38.30
3	11160.00	58.4 PK	74.0	-15.6	1.00 H	333	40.10	18.30
4	11160.00	47.0 AV	54.0	-7.0	1.00 H	333	28.70	18.30
ANTENNA POLARITY & TEST DISTANCE: VERTICAL AT 3 M								
NO.	FREQ. (MHz)	EMISSION LEVEL (dBuV/m)	LIMIT (dBuV/m)	MARGIN (dB)	ANTENNA HEIGHT (m)	TABLE ANGLE (Degree)	RAW VALUE (dBuV)	CORRECTION FACTOR (dB/m)
1	*5580.00	107.3 PK			1.15 V	270	69.00	38.30
2	*5580.00	97.2 AV			1.15 V	270	58.90	38.30
3	11160.00	59.3 PK	74.0	-14.7	1.00 V	96	41.00	18.30
4	11160.00	48.1 AV	54.0	-5.9	1.00 V	96	29.80	18.30

REMARKS:

1. Emission Level(dBuV/m) = Raw Value(dBuV) + Correction Factor(dB/m)
2. Correction Factor(dB/m) = Antenna Factor(dB/m) + Cable Factor(dB)
– Pre-Amplifier Factor(dB)
3. The other emission levels were very low against the limit.
4. Margin value = Emission Level – Limit value
5. “ * “: Fundamental frequency.



A D T

EUT TEST CONDITION		MEASUREMENT DETAIL	
CHANNEL	Channel 140	FREQUENCY RANGE	1 ~ 40GHz
INPUT POWER (SYSTEM)	120Vac, 60 Hz	DETECTOR FUNCTION	Peak (PK) Average (AV)
ENVIRONMENTAL CONDITIONS	24deg. C, 77%RH	TESTED BY	Martin Lee

ANTENNA POLARITY & TEST DISTANCE: HORIZONTAL AT 3 M								
NO.	FREQ. (MHz)	EMISSION LEVEL (dBuV/m)	LIMIT (dBuV/m)	MARGIN (dB)	ANTENNA HEIGHT (m)	TABLE ANGLE (Degree)	RAW VALUE (dBuV)	CORRECTION FACTOR (dB/m)
1	*5700.00	105.3 PK			1.00 H	296	66.80	38.50
2	*5700.00	95.0 AV			1.00 H	296	56.50	38.50
3	#5725.00	56.9 PK	74.0	-17.1	1.00 H	296	50.90	6.00
4	#5725.00	46.0 AV	54.0	-8.0	1.00 H	296	40.00	6.00
5	11400.00	58.9 PK	74.0	-15.1	1.00 H	201	40.10	18.80
6	11400.00	47.3 AV	54.0	-6.7	1.00 H	201	28.50	18.80
ANTENNA POLARITY & TEST DISTANCE: VERTICAL AT 3 M								
NO.	FREQ. (MHz)	EMISSION LEVEL (dBuV/m)	LIMIT (dBuV/m)	MARGIN (dB)	ANTENNA HEIGHT (m)	TABLE ANGLE (Degree)	RAW VALUE (dBuV)	CORRECTION FACTOR (dB/m)
1	*5700.00	107.0 PK			1.14 V	264	68.50	38.50
2	*5700.00	96.6 AV			1.14 V	264	58.10	38.50
3	#5725.00	57.6 PK	74.0	-16.4	1.14 V	264	51.60	6.00
4	#5725.00	46.0 AV	54.0	-8.0	1.14 V	264	40.00	6.00
5	11400.00	59.4 PK	74.0	-14.6	1.10 V	222	40.60	18.80
6	11400.00	48.4 AV	54.0	-5.6	1.10 V	222	29.60	18.80

REMARKS:

1. Emission Level(dBuV/m) = Raw Value(dBuV) + Correction Factor(dB/m)
2. Correction Factor(dB/m) = Antenna Factor(dB/m) + Cable Factor(dB)
– Pre-Amplifier Factor(dB)
3. The other emission levels were very low against the limit.
4. Margin value = Emission Level – Limit value
5. “ * “: Fundamental frequency.
6. “#”:The radiated frequency is out the restricted band.



802.11n (40MHz)

EUT TEST CONDITION		MEASUREMENT DETAIL	
CHANNEL	Channel 38	FREQUENCY RANGE	1 ~ 40GHz
INPUT POWER (SYSTEM)	120Vac, 60 Hz	DETECTOR FUNCTION	Peak (PK) Average (AV)
ENVIRONMENTAL CONDITIONS	24deg. C, 77%RH	TESTED BY	Martin Lee

ANTENNA POLARITY & TEST DISTANCE: HORIZONTAL AT 3 M								
NO.	FREQ. (MHz)	EMISSION LEVEL (dBuV/m)	LIMIT (dBuV/m)	MARGIN (dB)	ANTENNA HEIGHT (m)	TABLE ANGLE (Degree)	RAW VALUE (dBuV)	CORRECTION FACTOR (dB/m)
1	5150.00	55.9 PK	74.0	-18.1	1.12 H	239	50.80	5.10
2	5150.00	43.3 AV	54.0	-10.7	1.12 H	239	38.20	5.10
3	*5190.00	100.1 PK			1.12 H	239	62.30	37.80
4	*5190.00	88.9 AV			1.12 H	239	51.10	37.80
5	#10380.00	58.3 PK	74.0	-15.7	1.00 H	200	40.70	17.60
6	#10380.00	46.4 AV	54.0	-7.6	1.00 H	200	28.80	17.60

ANTENNA POLARITY & TEST DISTANCE: VERTICAL AT 3 M								
NO.	FREQ. (MHz)	EMISSION LEVEL (dBuV/m)	LIMIT (dBuV/m)	MARGIN (dB)	ANTENNA HEIGHT (m)	TABLE ANGLE (Degree)	RAW VALUE (dBuV)	CORRECTION FACTOR (dB/m)
1	5150.00	58.2 PK	74.0	-15.8	1.16 V	266	53.10	5.10
2	5150.00	44.6 AV	54.0	-9.4	1.16 V	266	39.50	5.10
3	*5190.00	104.5 PK			1.16 V	266	66.70	37.80
4	*5190.00	93.1 AV			1.16 V	266	55.30	37.80
5	#10380.00	59.4 PK	74.0	-14.6	1.05 V	116	41.80	17.60
6	#10380.00	46.8 AV	54.0	-7.2	1.05 V	116	29.20	17.60

REMARKS:

1. Emission Level(dBuV/m) = Raw Value(dBuV) + Correction Factor(dB/m)
2. Correction Factor(dB/m) = Antenna Factor(dB/m) + Cable Factor(dB) – Pre-Amplifier Factor(dB)
3. The other emission levels were very low against the limit.
4. Margin value = Emission Level – Limit value
5. “ * “: Fundamental frequency.
6. “#”:The radiated frequency is out the restricted band.



A D T

EUT TEST CONDITION		MEASUREMENT DETAIL	
CHANNEL	Channel 46	FREQUENCY RANGE	1 ~ 40GHz
INPUT POWER (SYSTEM)	120Vac, 60 Hz	DETECTOR FUNCTION	Peak (PK) Average (AV)
ENVIRONMENTAL CONDITIONS	24deg. C, 77%RH	TESTED BY	Martin Lee

ANTENNA POLARITY & TEST DISTANCE: HORIZONTAL AT 3 M								
NO.	FREQ. (MHz)	EMISSION LEVEL (dBuV/m)	LIMIT (dBuV/m)	MARGIN (dB)	ANTENNA HEIGHT (m)	TABLE ANGLE (Degree)	RAW VALUE (dBuV)	CORRECTION FACTOR (dB/m)
1	*5230.00	99.9 PK			1.11 H	298	62.00	37.90
2	*5230.00	89.9 AV			1.11 H	298	52.00	37.90
3	5350.00	55.1 PK	74.0	-18.9	1.11 H	298	49.70	5.40
4	5350.00	43.5 AV	54.0	-10.5	1.11 H	298	38.10	5.40
5	#10460.00	58.4 PK	74.0	-15.6	1.00 H	244	40.30	18.10
6	#10460.00	46.5 AV	54.0	-7.5	1.00 H	244	28.40	18.10
ANTENNA POLARITY & TEST DISTANCE: VERTICAL AT 3 M								
NO.	FREQ. (MHz)	EMISSION LEVEL (dBuV/m)	LIMIT (dBuV/m)	MARGIN (dB)	ANTENNA HEIGHT (m)	TABLE ANGLE (Degree)	RAW VALUE (dBuV)	CORRECTION FACTOR (dB/m)
1	*5230.00	104.4 PK			1.15 V	271	66.50	37.90
2	*5230.00	93.6 AV			1.15 V	271	55.70	37.90
3	5350.00	55.5 PK	74.0	-18.5	1.15 V	271	50.10	5.40
4	5350.00	43.8 AV	54.0	-10.2	1.15 V	271	38.40	5.40
5	#10460.00	58.1 PK	74.0	-15.9	1.00 V	164	40.00	18.10
6	#10460.00	46.3 AV	54.0	-7.7	1.00 V	164	28.20	18.10

REMARKS:

1. Emission Level(dBuV/m) = Raw Value(dBuV) + Correction Factor(dB/m)
2. Correction Factor(dB/m) = Antenna Factor(dB/m) + Cable Factor(dB) – Pre-Amplifier Factor(dB)
3. The other emission levels were very low against the limit.
4. Margin value = Emission Level – Limit value
5. “ * “: Fundamental frequency.
6. “#“:The radiated frequency is out the restricted band.



A D T

EUT TEST CONDITION		MEASUREMENT DETAIL	
CHANNEL	Channel 54	FREQUENCY RANGE	1 ~ 40GHz
INPUT POWER (SYSTEM)	120Vac, 60 Hz	DETECTOR FUNCTION	Peak (PK) Average (AV)
ENVIRONMENTAL CONDITIONS	24deg. C, 77%RH	TESTED BY	Martin Lee

ANTENNA POLARITY & TEST DISTANCE: HORIZONTAL AT 3 M								
NO.	FREQ. (MHz)	EMISSION LEVEL (dBuV/m)	LIMIT (dBuV/m)	MARGIN (dB)	ANTENNA HEIGHT (m)	TABLE ANGLE (Degree)	RAW VALUE (dBuV)	CORRECTION FACTOR (dB/m)
1	5150.00	55.1 PK	74.0	-18.9	1.19 H	103	50.00	5.10
2	5150.00	44.1 AV	54.0	-9.9	1.19 H	103	39.00	5.10
3	*5270.00	99.7 PK			1.19 H	103	61.80	37.90
4	*5270.00	89.6 AV			1.19 H	103	51.70	37.90
5	#10540.00	58.6 PK	74.0	-15.4	1.05 H	111	40.60	18.00
6	#10540.00	46.8 AV	54.0	-7.2	1.05 H	111	28.80	18.00
ANTENNA POLARITY & TEST DISTANCE: VERTICAL AT 3 M								
NO.	FREQ. (MHz)	EMISSION LEVEL (dBuV/m)	LIMIT (dBuV/m)	MARGIN (dB)	ANTENNA HEIGHT (m)	TABLE ANGLE (Degree)	RAW VALUE (dBuV)	CORRECTION FACTOR (dB/m)
1	5150.00	55.3 PK	74.0	-18.7	1.12 V	274	50.20	5.10
2	5150.00	43.7 AV	54.0	-10.3	1.12 V	274	38.60	5.10
3	*5270.00	104.8 PK			1.12 V	274	66.90	37.90
4	*5270.00	93.7 AV			1.12 V	274	55.80	37.90
5	#10540.00	59.2 PK	74.0	-14.8	1.00 V	355	41.20	18.00
6	#10540.00	47.1 AV	54.0	-6.9	1.00 V	355	29.10	18.00

REMARKS:

1. Emission Level(dBuV/m) = Raw Value(dBuV) + Correction Factor(dB/m)
2. Correction Factor(dB/m) = Antenna Factor(dB/m) + Cable Factor(dB)
– Pre-Amplifier Factor(dB)
3. The other emission levels were very low against the limit.
4. Margin value = Emission Level – Limit value
5. " * ": Fundamental frequency.
6. "#":The radiated frequency is out the restricted band.



A D T

EUT TEST CONDITION		MEASUREMENT DETAIL	
CHANNEL	Channel 62	FREQUENCY RANGE	1 ~ 40GHz
INPUT POWER (SYSTEM)	120Vac, 60 Hz	DETECTOR FUNCTION	Peak (PK) Average (AV)
ENVIRONMENTAL CONDITIONS	24deg. C, 77%RH	TESTED BY	Martin Lee

ANTENNA POLARITY & TEST DISTANCE: HORIZONTAL AT 3 M								
NO.	FREQ. (MHz)	EMISSION LEVEL (dBuV/m)	LIMIT (dBuV/m)	MARGIN (dB)	ANTENNA HEIGHT (m)	TABLE ANGLE (Degree)	RAW VALUE (dBuV)	CORRECTION FACTOR (dB/m)
1	*5310.00	100.4 PK			1.21 H	105	62.50	37.90
2	*5310.00	90.1 AV			1.21 H	105	52.20	37.90
3	5350.00	56.5 PK	74.0	-17.5	1.21 H	105	51.10	5.40
4	5350.00	44.4 AV	54.0	-9.6	1.21 H	105	39.00	5.40
5	10620.00	57.6 PK	74.0	-16.4	1.00 H	209	40.10	17.50
6	10620.00	46.2 AV	54.0	-7.8	1.00 H	209	28.70	17.50
ANTENNA POLARITY & TEST DISTANCE: VERTICAL AT 3 M								
NO.	FREQ. (MHz)	EMISSION LEVEL (dBuV/m)	LIMIT (dBuV/m)	MARGIN (dB)	ANTENNA HEIGHT (m)	TABLE ANGLE (Degree)	RAW VALUE (dBuV)	CORRECTION FACTOR (dB/m)
1	*5310.00	104.6 PK			1.14 V	268	66.70	37.90
2	*5310.00	93.4 AV			1.14 V	268	55.50	37.90
3	5350.00	58.4 PK	74.0	-15.6	1.14 V	268	53.00	5.40
4	5350.00	45.0 AV	54.0	-9.0	1.14 V	268	39.60	5.40
5	10620.00	58.0 PK	74.0	-16.0	1.00 V	289	40.50	17.50
6	10620.00	46.6 AV	54.0	-7.4	1.00 V	289	29.10	17.50

REMARKS:

1. Emission Level(dBuV/m) = Raw Value(dBuV) + Correction Factor(dB/m)
2. Correction Factor(dB/m) = Antenna Factor(dB/m) + Cable Factor(dB)
– Pre-Amplifier Factor(dB)
3. The other emission levels were very low against the limit.
4. Margin value = Emission Level – Limit value
5. “ * “: Fundamental frequency.



A D T

EUT TEST CONDITION		MEASUREMENT DETAIL	
CHANNEL	Channel 102	FREQUENCY RANGE	1 ~ 40GHz
INPUT POWER (SYSTEM)	120Vac, 60 Hz	DETECTOR FUNCTION	Peak (PK) Average (AV)
ENVIRONMENTAL CONDITIONS	24deg. C, 77%RH	TESTED BY	Martin Lee

ANTENNA POLARITY & TEST DISTANCE: HORIZONTAL AT 3 M								
NO.	FREQ. (MHz)	EMISSION LEVEL (dBuV/m)	LIMIT (dBuV/m)	MARGIN (dB)	ANTENNA HEIGHT (m)	TABLE ANGLE (Degree)	RAW VALUE (dBuV)	CORRECTION FACTOR (dB/m)
1	5460.00	55.4 PK	74.0	-18.6	1.15 H	294	49.80	5.60
2	5460.00	43.8 AV	54.0	-10.2	1.15 H	294	38.20	5.60
3	#5470.00	57.5 PK	74.0	-16.5	1.15 H	294	51.80	5.70
4	#5470.00	44.4 AV	54.0	-9.6	1.15 H	294	38.70	5.70
5	*5510.00	100.1 PK			1.15 H	294	61.80	38.30
6	*5510.00	89.2 AV			1.15 H	294	50.90	38.30
7	11020.00	58.3 PK	74.0	-15.7	1.00 H	179	40.00	18.30
8	11020.00	47.8 AV	54.0	-6.2	1.00 H	179	29.50	18.30

ANTENNA POLARITY & TEST DISTANCE: VERTICAL AT 3 M								
NO.	FREQ. (MHz)	EMISSION LEVEL (dBuV/m)	LIMIT (dBuV/m)	MARGIN (dB)	ANTENNA HEIGHT (m)	TABLE ANGLE (Degree)	RAW VALUE (dBuV)	CORRECTION FACTOR (dB/m)
1	5460.00	55.6 PK	74.0	-18.4	1.10 V	274	50.00	5.60
2	5460.00	44.0 AV	54.0	-10.0	1.10 V	274	38.40	5.60
3	#5470.00	57.2 PK	74.0	-16.8	1.10 V	274	51.50	5.70
4	#5470.00	45.2 AV	54.0	-8.8	1.10 V	274	39.50	5.70
5	*5510.00	104.3 PK			1.10 V	274	66.00	38.30
6	*5510.00	93.1 AV			1.10 V	274	54.80	38.30
7	11020.00	59.1 PK	74.0	-14.9	1.00 V	349	40.80	18.30
8	11020.00	48.4 AV	54.0	-5.6	1.00 V	349	30.10	18.30

REMARKS:

1. Emission Level(dBuV/m) = Raw Value(dBuV) + Correction Factor(dB/m)
2. Correction Factor(dB/m) = Antenna Factor(dB/m) + Cable Factor(dB) – Pre-Amplifier Factor(dB)
3. The other emission levels were very low against the limit.
4. Margin value = Emission Level – Limit value
5. “ * “: Fundamental frequency.
6. “#”:The radiated frequency is out the restricted band.

EUT TEST CONDITION		MEASUREMENT DETAIL	
CHANNEL	Channel 110	FREQUENCY RANGE	1 ~ 40GHz
INPUT POWER (SYSTEM)	120Vac, 60 Hz	DETECTOR FUNCTION	Peak (PK) Average (AV)
ENVIRONMENTAL CONDITIONS	24deg. C, 77%RH	TESTED BY	Martin Lee

ANTENNA POLARITY & TEST DISTANCE: HORIZONTAL AT 3 M								
NO.	FREQ. (MHz)	EMISSION LEVEL (dBuV/m)	LIMIT (dBuV/m)	MARGIN (dB)	ANTENNA HEIGHT (m)	TABLE ANGLE (Degree)	RAW VALUE (dBuV)	CORRECTION FACTOR (dB/m)
1	*5550.00	99.9 PK			1.12 H	301	61.60	38.30
2	*5550.00	88.8 AV			1.12 H	301	50.50	38.30
3	11100.00	58.7 PK	74.0	-15.3	1.00 H	49	40.40	18.30
4	11100.00	47.7 AV	54.0	-6.3	1.00 H	49	29.40	18.30
ANTENNA POLARITY & TEST DISTANCE: VERTICAL AT 3 M								
NO.	FREQ. (MHz)	EMISSION LEVEL (dBuV/m)	LIMIT (dBuV/m)	MARGIN (dB)	ANTENNA HEIGHT (m)	TABLE ANGLE (Degree)	RAW VALUE (dBuV)	CORRECTION FACTOR (dB/m)
1	*5550.00	104.1 PK			1.22 V	266	65.80	38.30
2	*5550.00	91.8 AV			1.22 V	266	53.50	38.30
3	11100.00	59.6 PK	74.0	-14.4	1.00 V	337	41.30	18.30
4	11100.00	48.2 AV	54.0	-5.8	1.00 V	337	29.90	18.30

REMARKS:

1. Emission Level(dBuV/m) = Raw Value(dBuV) + Correction Factor(dB/m)
2. Correction Factor(dB/m) = Antenna Factor(dB/m) + Cable Factor(dB)
– Pre-Amplifier Factor (dB)
3. The other emission levels were very low against the limit.
4. Margin value = Emission Level – Limit value
5. “ * “: Fundamental frequency.
6. "#":The radiated frequency is out the restricted band.



A D T

EUT TEST CONDITION		MEASUREMENT DETAIL	
CHANNEL	Channel 134	FREQUENCY RANGE	1 ~ 40GHz
INPUT POWER (SYSTEM)	120Vac, 60 Hz	DETECTOR FUNCTION	Peak (PK) Average (AV)
ENVIRONMENTAL CONDITIONS	24deg. C, 77%RH	TESTED BY	Martin Lee

ANTENNA POLARITY & TEST DISTANCE: HORIZONTAL AT 3 M								
NO.	FREQ. (MHz)	EMISSION LEVEL (dBuV/m)	LIMIT (dBuV/m)	MARGIN (dB)	ANTENNA HEIGHT (m)	TABLE ANGLE (Degree)	RAW VALUE (dBuV)	CORRECTION FACTOR (dB/m)
1	*5670.00	100.2 PK			1.00 H	299	61.80	38.40
2	*5670.00	89.4 AV			1.00 H	299	51.00	38.40
3	#5725.00	56.5 PK	74.0	-17.5	1.00 H	299	50.50	6.00
4	#5725.00	44.6 AV	54.0	-9.4	1.00 H	299	38.60	6.00
5	11340.00	59.0 PK	74.0	-15.0	1.00 H	66	40.40	18.60
6	11340.00	48.2 AV	54.0	-5.8	1.00 H	66	29.60	18.60
ANTENNA POLARITY & TEST DISTANCE: VERTICAL AT 3 M								
NO.	FREQ. (MHz)	EMISSION LEVEL (dBuV/m)	LIMIT (dBuV/m)	MARGIN (dB)	ANTENNA HEIGHT (m)	TABLE ANGLE (Degree)	RAW VALUE (dBuV)	CORRECTION FACTOR (dB/m)
1	*5670.00	103.4 PK			1.24 V	267	65.00	38.40
2	*5670.00	91.4 AV			1.24 V	267	53.00	38.40
3	#5725.00	57.1 PK	74.0	-16.9	1.24 V	267	51.10	6.00
4	#5725.00	44.9 AV	54.0	-9.1	1.24 V	267	38.90	6.00
5	11340.00	59.4 PK	74.0	-14.6	1.00 V	156	40.80	18.60
6	11340.00	48.6 AV	54.0	-5.4	1.00 V	156	30.00	18.60

REMARKS:

1. Emission Level(dBuV/m) = Raw Value(dBuV) + Correction Factor(dB/m)
2. Correction Factor(dB/m) = Antenna Factor(dB/m) + Cable Factor(dB) – Pre-Amplifier Factor(dB)
3. The other emission levels were very low against the limit.
4. Margin value = Emission Level – Limit value
5. “ * “: Fundamental frequency.
6. “#”:The radiated frequency is out the restricted band.

802.11ac (80MHz)

EUT TEST CONDITION		MEASUREMENT DETAIL	
CHANNEL	Channel 42	FREQUENCY RANGE	1 ~ 40GHz
INPUT POWER (SYSTEM)	120Vac, 60 Hz	DETECTOR FUNCTION	Peak (PK) Average (AV)
ENVIRONMENTAL CONDITIONS	24deg. C, 77%RH	TESTED BY	Martin Lee

ANTENNA POLARITY & TEST DISTANCE: HORIZONTAL AT 3 M								
NO.	FREQ. (MHz)	EMISSION LEVEL (dBuV/m)	LIMIT (dBuV/m)	MARGIN (dB)	ANTENNA HEIGHT (m)	TABLE ANGLE (Degree)	RAW VALUE (dBuV)	CORRECTION FACTOR (dB/m)
1	5150.00	55.8 PK	74.0	-18.2	1.23 H	237	50.70	5.10
2	5150.00	44.1 AV	54.0	-9.9	1.23 H	237	39.00	5.10
3	*5210.00	96.1 PK			1.23 H	237	58.30	37.80
4	*5210.00	85.3 AV			1.23 H	237	47.50	37.80
5	#10420.00	58.0 PK	74.0	-16.0	1.00 H	98	40.10	17.90
6	#10420.00	46.8 AV	54.0	-7.2	1.00 H	98	28.90	17.90

ANTENNA POLARITY & TEST DISTANCE: VERTICAL AT 3 M								
NO.	FREQ. (MHz)	EMISSION LEVEL (dBuV/m)	LIMIT (dBuV/m)	MARGIN (dB)	ANTENNA HEIGHT (m)	TABLE ANGLE (Degree)	RAW VALUE (dBuV)	CORRECTION FACTOR (dB/m)
1	5150.00	58.6 PK	74.0	-15.4	1.27 V	266	53.50	5.10
2	5150.00	44.9 AV	54.0	-9.1	1.27 V	266	39.80	5.10
3	*5210.00	100.7 PK			1.27 V	266	62.90	37.80
4	*5210.00	90.6 AV			1.27 V	266	52.80	37.80
5	#10420.00	58.4 PK	74.0	-15.6	1.10 V	249	40.50	17.90
6	#10420.00	47.6 AV	54.0	-6.4	1.10 V	249	29.70	17.90

REMARKS:

1. Emission level (dBuV/m) = Raw Value (dBuV) + Correction Factor (dB/m).
2. Correction Factor (dB/m) = Antenna Factor (dB/m) + Cable Factor (dB).
3. The other emission levels were very low against the limit.
4. Margin value = Emission level – Limit value.
5. “ * “: Fundamental frequency.
6. “#”:The radiated frequency is out the restricted band.



A D T

EUT TEST CONDITION		MEASUREMENT DETAIL	
CHANNEL	Channel 58	FREQUENCY RANGE	1 ~ 40GHz
INPUT POWER (SYSTEM)	120Vac, 60 Hz	DETECTOR FUNCTION	Peak (PK) Average (AV)
ENVIRONMENTAL CONDITIONS	24deg. C, 77%RH	TESTED BY	Martin Lee

ANTENNA POLARITY & TEST DISTANCE: HORIZONTAL AT 3 M								
NO.	FREQ. (MHz)	EMISSION LEVEL (dBuV/m)	LIMIT (dBuV/m)	MARGIN (dB)	ANTENNA HEIGHT (m)	TABLE ANGLE (Degree)	RAW VALUE (dBuV)	CORRECTION FACTOR (dB/m)
1	*5290.00	97.6 PK			1.09 H	290	59.30	38.30
2	*5290.00	86.9 AV			1.09 H	290	48.60	38.30
3	5350.00	55.3 PK	74.0	-18.7	1.09 H	290	49.50	5.80
4	5350.00	35.7 AV	54.0	-18.3	1.09 H	290	29.90	5.80
5	#10580.00	59.0 PK	74.0	-15.0	1.00 H	78	41.20	17.80
6	#10580.00	46.9 AV	54.0	-7.1	1.00 H	78	29.10	17.80
ANTENNA POLARITY & TEST DISTANCE: VERTICAL AT 3 M								
NO.	FREQ. (MHz)	EMISSION LEVEL (dBuV/m)	LIMIT (dBuV/m)	MARGIN (dB)	ANTENNA HEIGHT (m)	TABLE ANGLE (Degree)	RAW VALUE (dBuV)	CORRECTION FACTOR (dB/m)
1	*5290.00	100.7 PK			1.36 V	269	62.40	38.30
2	*5290.00	90.6 AV			1.36 V	269	52.30	38.30
3	5350.00	58.0 PK	74.0	-16.0	1.36 V	269	52.20	5.80
4	5350.00	45.9 AV	54.0	-8.1	1.36 V	269	40.10	5.80
5	#10580.00	59.5 PK	74.0	-14.5	1.00 V	168	41.70	17.80
6	#10580.00	47.3 AV	54.0	-6.7	1.00 V	168	29.50	17.80

REMARKS:

1. Emission level (dBuV/m) = Raw Value (dBuV) + Correction Factor (dB/m).
2. Correction Factor (dB/m) = Antenna Factor (dB/m) + Cable Factor (dB).
3. The other emission levels were very low against the limit.
4. Margin value = Emission level – Limit value.
5. “ * “: Fundamental frequency.
6. “#”: The radiated frequency is out the restricted band.



A D T

EUT TEST CONDITION		MEASUREMENT DETAIL	
CHANNEL	Channel 106	FREQUENCY RANGE	1 ~ 40GHz
INPUT POWER (SYSTEM)	120Vac, 60 Hz	DETECTOR FUNCTION	Peak (PK) Average (AV)
ENVIRONMENTAL CONDITIONS	24deg. C, 77%RH	TESTED BY	Martin Lee

ANTENNA POLARITY & TEST DISTANCE: HORIZONTAL AT 3 M								
NO.	FREQ. (MHz)	EMISSION LEVEL (dBuV/m)	LIMIT (dBuV/m)	MARGIN (dB)	ANTENNA HEIGHT (m)	TABLE ANGLE (Degree)	RAW VALUE (dBuV)	CORRECTION FACTOR (dB/m)
1	5460.00	55.7 PK	74.0	-18.3	1.04 H	296	50.10	5.60
2	5460.00	44.7 AV	54.0	-9.3	1.04 H	296	39.10	5.60
3	#5470.00	55.5 PK	74.0	-18.5	1.04 H	296	49.80	5.70
4	#5470.00	45.0 AV	54.0	-9.0	1.04 H	296	39.30	5.70
5	*5530.00	96.2 PK			1.05 H	296	58.00	38.20
6	*5530.00	86.1 AV			1.05 H	296	47.90	38.20
7	11060.00	58.4 PK	74.0	-15.6	1.00 H	19	40.20	18.20
8	11060.00	46.7 AV	54.0	-7.3	1.00 H	19	28.50	18.20
ANTENNA POLARITY & TEST DISTANCE: VERTICAL AT 3 M								
NO.	FREQ. (MHz)	EMISSION LEVEL (dBuV/m)	LIMIT (dBuV/m)	MARGIN (dB)	ANTENNA HEIGHT (m)	TABLE ANGLE (Degree)	RAW VALUE (dBuV)	CORRECTION FACTOR (dB/m)
1	5460.00	56.5 PK	74.0	-17.5	1.19 V	274	50.90	5.60
2	5460.00	45.3 AV	54.0	-8.7	1.19 V	274	39.70	5.60
3	#5470.00	56.5 PK	74.0	-17.5	1.19 V	274	50.80	5.70
4	#5470.00	46.2 AV	54.0	-7.8	1.19 V	274	40.50	5.70
5	*5530.00	99.2 PK			1.19 V	274	61.00	38.20
6	*5530.00	89.3 AV			1.19 V	274	51.10	38.20
7	11060.00	59.1 PK	74.0	-14.9	1.00 V	319	40.90	18.20
8	11060.00	47.2 AV	54.0	-6.8	1.00 V	319	29.00	18.20

REMARKS:

1. Emission level (dBuV/m) = Raw Value (dBuV) + Correction Factor (dB/m).
2. Correction Factor (dB/m) = Antenna Factor (dB/m) + Cable Factor (dB).
3. The other emission levels were very low against the limit.
4. Margin value = Emission level – Limit value.
5. “ * “: Fundamental frequency.
6. “#”:The radiated frequency is out the restricted band.

BELOW 1GHz WORST-CASE DATA : 802.11a

EUT TEST CONDITION		MEASUREMENT DETAIL	
CHANNEL	Channel 48	FREQUENCY RANGE	Below 1000MHz
INPUT POWER (SYSTEM)	120Vac, 60 Hz	DETECTOR FUNCTION	Quasi-Peak
ENVIRONMENTAL CONDITIONS	25deg. C, 65%RH	TESTED BY	Chris Lin
TEST MODE	A		

ANTENNA POLARITY & TEST DISTANCE: HORIZONTAL AT 3 M								
NO.	FREQ. (MHz)	EMISSION LEVEL (dBuV/m)	LIMIT (dBuV/m)	MARGIN (dB)	ANTENNA HEIGHT (m)	TABLE ANGLE (Degree)	RAW VALUE (dBuV)	CORRECTION FACTOR (dB/m)
1	57.07	28.5 QP	40.0	-11.5	1.25 H	184	43.10	-14.60
2	216.18	21.3 QP	46.0	-24.7	1.00 H	357	37.50	-16.20
3	359.77	21.9 QP	46.0	-24.1	1.50 H	51	33.00	-11.10
4	458.73	20.3 QP	46.0	-25.7	1.00 H	7	29.30	-9.00
5	633.36	23.2 QP	46.0	-22.8	1.50 H	179	28.40	-5.20
6	767.25	25.2 QP	46.0	-20.8	1.25 H	7	27.80	-2.60

ANTENNA POLARITY & TEST DISTANCE: VERTICAL AT 3 M								
NO.	FREQ. (MHz)	EMISSION LEVEL (dBuV/m)	LIMIT (dBuV/m)	MARGIN (dB)	ANTENNA HEIGHT (m)	TABLE ANGLE (Degree)	RAW VALUE (dBuV)	CORRECTION FACTOR (dB/m)
1	57.07	27.0 QP	40.0	-13.0	1.25 V	282	41.60	-14.60
2	107.52	18.4 QP	43.5	-25.1	1.00 V	141	35.80	-17.40
3	348.13	16.5 QP	46.0	-29.5	1.50 V	60	27.80	-11.30
4	602.32	22.9 QP	46.0	-23.1	1.00 V	71	29.00	-6.10
5	745.91	24.5 QP	46.0	-21.5	1.50 V	93	27.70	-3.20
6	947.71	29.0 QP	46.0	-17.0	1.25 V	220	28.60	0.40

REMARKS:

1. Emission Level(dBuV/m) = Raw Value(dBuV) + Correction Factor(dB/m)
2. Correction Factor(dB/m) = Antenna Factor(dB/m) + Cable Factor(dB) – Pre-Amplifier Factor (dB)
3. The other emission levels were very low against the limit.
4. Margin value = Emission Level – Limit value



A D T

EUT TEST CONDITION		MEASUREMENT DETAIL	
CHANNEL	Channel 48	FREQUENCY RANGE	Below 1000MHz
INPUT POWER (SYSTEM)	120Vac, 60 Hz	DETECTOR FUNCTION	Quasi-Peak
ENVIRONMENTAL CONDITIONS	25deg. C, 65%RH	TESTED BY	Chris Lin
TEST MODE	B		

ANTENNA POLARITY & TEST DISTANCE: HORIZONTAL AT 3 M								
NO.	FREQ. (MHz)	EMISSION LEVEL (dBuV/m)	LIMIT (dBuV/m)	MARGIN (dB)	ANTENNA HEIGHT (m)	TABLE ANGLE (Degree)	RAW VALUE (dBuV)	CORRECTION FACTOR (dB/m)
1	37.66	28.8 QP	40.0	-11.2	1.25 H	104	43.90	-15.10
2	169.61	22.5 QP	43.5	-21.0	1.00 H	239	36.50	-14.00
3	359.77	31.1 QP	46.0	-14.9	1.50 H	133	42.20	-11.10
4	528.58	22.8 QP	46.0	-23.2	1.25 H	329	30.50	-7.70
5	743.97	25.2 QP	46.0	-20.8	1.00 H	160	28.60	-3.40
6	941.89	29.2 QP	46.0	-16.8	1.50 H	57	28.90	0.30

ANTENNA POLARITY & TEST DISTANCE: VERTICAL AT 3 M								
NO.	FREQ. (MHz)	EMISSION LEVEL (dBuV/m)	LIMIT (dBuV/m)	MARGIN (dB)	ANTENNA HEIGHT (m)	TABLE ANGLE (Degree)	RAW VALUE (dBuV)	CORRECTION FACTOR (dB/m)
1	37.66	38.1 QP	40.0	-1.9	1.25 V	311	53.20	-15.10
2	57.07	31.2 QP	40.0	-8.8	1.00 V	312	45.80	-14.60
3	84.23	28.7 QP	40.0	-11.3	1.50 V	114	48.20	-19.50
4	359.77	29.4 QP	46.0	-16.6	1.00 V	59	40.50	-11.10
5	480.07	28.3 QP	46.0	-17.7	1.25 V	57	36.90	-8.60
6	528.58	29.5 QP	46.0	-16.5	1.50 V	68	37.20	-7.70

REMARKS:

1. Emission Level(dBuV/m) = Raw Value(dBuV) + Correction Factor(dB/m)
2. Correction Factor(dB/m) = Antenna Factor(dB/m) + Cable Factor(dB) – Pre-Amplifier Factor (dB)
3. The other emission levels were very low against the limit.
4. Margin value = Emission Level – Limit value



A D T

EUT TEST CONDITION		MEASUREMENT DETAIL	
CHANNEL	Channel 48	FREQUENCY RANGE	Below 1000MHz
INPUT POWER (SYSTEM)	120Vac, 60 Hz	DETECTOR FUNCTION	Quasi-Peak
ENVIRONMENTAL CONDITIONS	25deg. C, 65%RH	TESTED BY	Chris Lin
TEST MODE	C		

ANTENNA POLARITY & TEST DISTANCE: HORIZONTAL AT 3 M								
NO.	FREQ. (MHz)	EMISSION LEVEL (dBuV/m)	LIMIT (dBuV/m)	MARGIN (dB)	ANTENNA HEIGHT (m)	TABLE ANGLE (Degree)	RAW VALUE (dBuV)	CORRECTION FACTOR (dB/m)
1	57.07	30.0 QP	40.0	-10.0	1.25 H	93	44.60	-14.60
2	154.09	32.8 QP	43.5	-10.7	1.00 H	280	46.20	-13.40
3	231.70	37.0 QP	46.0	-9.0	1.50 H	124	52.80	-15.80
4	431.56	28.6 QP	46.0	-17.4	1.25 H	109	38.10	-9.50
5	666.35	32.8 QP	46.0	-13.2	1.00 H	57	37.70	-4.90
6	840.99	32.0 QP	46.0	-14.0	1.50 H	57	33.60	-1.60

ANTENNA POLARITY & TEST DISTANCE: VERTICAL AT 3 M								
NO.	FREQ. (MHz)	EMISSION LEVEL (dBuV/m)	LIMIT (dBuV/m)	MARGIN (dB)	ANTENNA HEIGHT (m)	TABLE ANGLE (Degree)	RAW VALUE (dBuV)	CORRECTION FACTOR (dB/m)
1	55.13	36.3 QP	40.0	-3.7	1.25 V	185	50.30	-14.00
2	99.75	34.3 QP	43.5	-9.2	1.00 V	64	52.70	-18.40
3	233.64	33.7 QP	46.0	-12.3	1.50 V	68	49.20	-15.50
4	493.66	32.5 QP	46.0	-13.5	1.00 V	173	41.10	-8.60
5	664.41	30.2 QP	46.0	-15.8	1.50 V	5	35.10	-4.90
6	840.99	32.4 QP	46.0	-13.6	1.25 V	106	34.00	-1.60

REMARKS:

1. Emission Level(dBuV/m) = Raw Value(dBuV) + Correction Factor(dB/m)
2. Correction Factor(dB/m) = Antenna Factor(dB/m) + Cable Factor(dB) – Pre-Amplifier Factor (dB)
3. The other emission levels were very low against the limit.
4. Margin value = Emission Level – Limit value



A D T

EUT TEST CONDITION		MEASUREMENT DETAIL	
CHANNEL	Channel 100	FREQUENCY RANGE	Below 1000MHz
INPUT POWER (SYSTEM)	120Vac, 60 Hz	DETECTOR FUNCTION	Quasi-Peak
ENVIRONMENTAL CONDITIONS	25deg. C, 65%RH	TESTED BY	Chris Lin
TEST MODE	A		

ANTENNA POLARITY & TEST DISTANCE: HORIZONTAL AT 3 M								
NO.	FREQ. (MHz)	EMISSION LEVEL (dBuV/m)	LIMIT (dBuV/m)	MARGIN (dB)	ANTENNA HEIGHT (m)	TABLE ANGLE (Degree)	RAW VALUE (dBuV)	CORRECTION FACTOR (dB/m)
1	57.07	28.2 QP	40.0	-11.8	1.25 H	31	42.80	-14.60
2	216.18	20.5 QP	46.0	-25.5	1.00 H	343	36.70	-16.20
3	408.28	22.6 QP	46.0	-23.4	1.00 H	302	32.80	-10.20
4	592.62	22.2 QP	46.0	-23.8	1.50 H	174	28.50	-6.30
5	747.85	25.9 QP	46.0	-20.1	1.25 H	234	29.10	-3.20
6	936.07	29.1 QP	46.0	-16.9	1.50 H	81	28.80	0.30

ANTENNA POLARITY & TEST DISTANCE: VERTICAL AT 3 M								
NO.	FREQ. (MHz)	EMISSION LEVEL (dBuV/m)	LIMIT (dBuV/m)	MARGIN (dB)	ANTENNA HEIGHT (m)	TABLE ANGLE (Degree)	RAW VALUE (dBuV)	CORRECTION FACTOR (dB/m)
1	57.07	26.8 QP	40.0	-13.2	1.25 V	142	41.40	-14.60
2	142.44	14.6 QP	43.5	-28.9	1.00 V	132	28.80	-14.20
3	435.44	19.0 QP	46.0	-27.0	1.50 V	37	28.40	-9.40
4	610.08	24.7 QP	46.0	-21.3	1.00 V	291	30.50	-5.80
5	804.12	26.5 QP	46.0	-19.5	1.50 V	45	28.60	-2.10
6	901.14	28.5 QP	46.0	-17.5	1.25 V	14	28.90	-0.40

REMARKS:

1. Emission Level(dBuV/m) = Raw Value(dBuV) + Correction Factor(dB/m)
2. Correction Factor(dB/m) = Antenna Factor(dB/m) + Cable Factor(dB) – Pre-Amplifier Factor (dB)
3. The other emission levels were very low against the limit.
4. Margin value = Emission Level – Limit value



A D T

EUT TEST CONDITION		MEASUREMENT DETAIL	
CHANNEL	Channel 100	FREQUENCY RANGE	Below 1000MHz
INPUT POWER (SYSTEM)	120Vac, 60 Hz	DETECTOR FUNCTION	Quasi-Peak
ENVIRONMENTAL CONDITIONS	25deg. C, 65%RH	TESTED BY	Chris Lin
TEST MODE	B		

ANTENNA POLARITY & TEST DISTANCE: HORIZONTAL AT 3 M								
NO.	FREQ. (MHz)	EMISSION LEVEL (dBuV/m)	LIMIT (dBuV/m)	MARGIN (dB)	ANTENNA HEIGHT (m)	TABLE ANGLE (Degree)	RAW VALUE (dBuV)	CORRECTION FACTOR (dB/m)
1	57.07	28.8 QP	40.0	-11.2	1.25 H	264	43.40	-14.60
2	161.85	23.2 QP	43.5	-20.3	1.00 H	237	36.60	-13.40
3	359.77	31.1 QP	46.0	-14.9	1.50 H	134	42.20	-11.10
4	528.58	23.2 QP	46.0	-22.8	1.00 H	333	30.90	-7.70
5	693.52	24.6 QP	46.0	-21.4	1.25 H	150	29.20	-4.60
6	961.29	29.2 QP	54.0	-24.8	1.50 H	134	28.50	0.70

ANTENNA POLARITY & TEST DISTANCE: VERTICAL AT 3 M								
NO.	FREQ. (MHz)	EMISSION LEVEL (dBuV/m)	LIMIT (dBuV/m)	MARGIN (dB)	ANTENNA HEIGHT (m)	TABLE ANGLE (Degree)	RAW VALUE (dBuV)	CORRECTION FACTOR (dB/m)
1	35.72	37.5 QP	40.0	-2.5	1.25 V	299	52.30	-14.80
2	57.07	32.4 QP	40.0	-7.6	1.00 V	18	47.00	-14.60
3	86.17	29.0 QP	40.0	-11.0	1.50 V	120	48.50	-19.50
4	359.77	29.4 QP	46.0	-16.6	1.00 V	281	40.50	-11.10
5	528.58	28.6 QP	46.0	-17.4	1.50 V	78	36.30	-7.70
6	969.05	30.0 QP	54.0	-24.0	1.25 V	253	29.20	0.80

REMARKS:

1. Emission Level(dBuV/m) = Raw Value(dBuV) + Correction Factor(dB/m)
2. Correction Factor(dB/m) = Antenna Factor(dB/m) + Cable Factor(dB) – Pre-Amplifier Factor (dB)
3. The other emission levels were very low against the limit.
4. Margin value = Emission Level – Limit value



A D T

EUT TEST CONDITION		MEASUREMENT DETAIL	
CHANNEL	Channel 100	FREQUENCY RANGE	Below 1000MHz
INPUT POWER (SYSTEM)	120Vac, 60 Hz	DETECTOR FUNCTION	Quasi-Peak
ENVIRONMENTAL CONDITIONS	25deg. C, 65%RH	TESTED BY	Chris Lin
TEST MODE	C		

ANTENNA POLARITY & TEST DISTANCE: HORIZONTAL AT 3 M								
NO.	FREQ. (MHz)	EMISSION LEVEL (dBuV/m)	LIMIT (dBuV/m)	MARGIN (dB)	ANTENNA HEIGHT (m)	TABLE ANGLE (Degree)	RAW VALUE (dBuV)	CORRECTION FACTOR (dB/m)
1	57.07	29.2 QP	40.0	-10.8	1.25 H	67	43.80	-14.60
2	154.09	32.5 QP	43.5	-11.0	1.00 H	305	45.90	-13.40
3	231.70	37.7 QP	46.0	-8.3	1.50 H	119	53.50	-15.80
4	272.45	31.2 QP	46.0	-14.8	1.00 H	219	44.10	-12.90
5	431.56	28.8 QP	46.0	-17.2	1.50 H	118	38.30	-9.50
6	666.35	32.7 QP	46.0	-13.3	2.00 H	75	37.60	-4.90

ANTENNA POLARITY & TEST DISTANCE: VERTICAL AT 3 M								
NO.	FREQ. (MHz)	EMISSION LEVEL (dBuV/m)	LIMIT (dBuV/m)	MARGIN (dB)	ANTENNA HEIGHT (m)	TABLE ANGLE (Degree)	RAW VALUE (dBuV)	CORRECTION FACTOR (dB/m)
1	55.13	37.1 QP	40.0	-2.9	1.25 V	279	51.10	-14.00
2	144.38	32.8 QP	43.5	-10.7	1.00 V	150	46.80	-14.00
3	231.70	34.5 QP	46.0	-11.5	1.50 V	46	50.30	-15.80
4	495.60	34.2 QP	46.0	-11.8	1.00 V	151	42.70	-8.50
5	666.35	30.3 QP	46.0	-15.7	1.00 V	7	35.20	-4.90
6	840.99	32.6 QP	46.0	-13.4	1.50 V	94	34.20	-1.60

REMARKS:

1. Emission Level(dBuV/m) = Raw Value(dBuV) + Correction Factor(dB/m)
2. Correction Factor(dB/m) = Antenna Factor(dB/m) + Cable Factor(dB) – Pre-Amplifier Factor (dB)
3. The other emission levels were very low against the limit.
4. Margin value = Emission Level – Limit value

4.2 CONDUCTED EMISSION MEASUREMENT

4.2.1 LIMITS OF CONDUCTED EMISSION MEASUREMENT

FREQUENCY OF EMISSION (MHz)	CONDUCTED LIMIT (dBµV)	
	Quasi-peak	Average
0.15 ~ 0.5	66 to 56	56 to 46
0.5 ~ 5	56	46
5 ~ 30	60	50

- NOTE:**
1. The lower limit shall apply at the transition frequencies.
 2. The limit decreases in line with the logarithm of the frequency in the range of 0.15 to 0.50MHz.
 3. All emanations from a class A/B digital device or system, including any network of conductors and apparatus connected thereto, shall not exceed the level of field strengths specified above.

4.2.2 TEST INSTRUMENTS

DESCRIPTION & MANUFACTURER	MODEL NO.	SERIAL NO.	DATE OF CALIBRATION	DUE DATE OF CALIBRATION
Test Receiver ROHDE & SCHWARZ	ESCS30	100289	Nov. 16, 2012	Nov. 15, 2013
RF signal cable Woken	5D-FB	Cable-HYC01-01	Dec. 28, 2012	Dec. 27, 2013
LISN ROHDE & SCHWARZ (EUT)	ESH3-Z5	835239/001	Feb. 04, 2013	Feb. 03, 2014
LISN ROHDE & SCHWARZ (Peripheral)	ESH3-Z5	100312	Jul. 08, 2013	Jul. 07, 2014
Software ADT	BV ADT_Cond_ V7.3.7.3	NA	NA	NA

- NOTE:**
1. The calibration interval of the above test instruments is 12 months and the calibrations are traceable to NML/ROC and NIST/USA.
 2. The test was performed in HwaYa Shielded Room 1.
 3. The VCCI Site Registration No. is C-2040.

4.2.3 TEST PROCEDURES

- a. The EUT was placed 0.4 meters from the conducting wall of the shielded room with EUT being connected to the power mains through a line impedance stabilization network (LISN). Other support units were connected to the power mains through another LISN. The two LISNs provide 50 ohm/ 50uH of coupling impedance for the measuring instrument.
- b. Both lines of the power mains connected to the EUT were checked for maximum conducted interference.
- c. The frequency range from 150kHz to 30MHz was searched. Emission levels under (Limit - 20dB) was not recorded.

NOTE: All modes of operation were investigated and the worst-case emissions are reported.

4.2.4 DEVIATION FROM TEST STANDARD

No deviation.

4.2.5 TEST SETUP

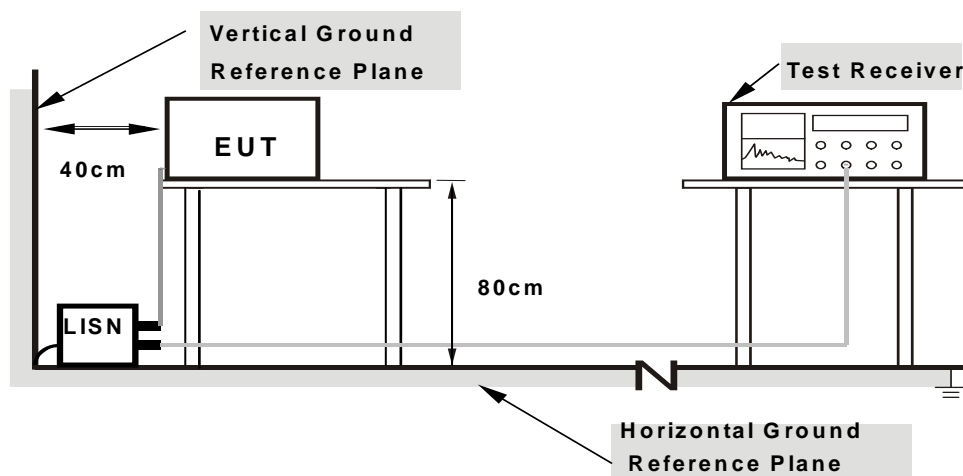

- Note:**
1. Support units were connected to second LISN.
 2. Both of LISNs (AMN) are 80 cm from EUT and at least 80 from other units and other metal planes

For the actual test configuration, please refer to the attached file (Test Setup Photo).

4.2.6 EUT OPERATING CONDITIONS

Same as 4.1.6.

4.2.7 TEST RESULTS

CONDUCTED WORST-CASE DATA : 802.11a

PHASE	Line 1	6dB BANDWIDTH	9kHz
CHANNEL	Channel 48	TEST MODE	A

No	Freq. [MHz]	Corr. Factor (dB)	Reading Value		Emission Level		Limit		Margin	
			[dB (uV)]		[dB (uV)]		[dB (uV)]		(dB)	
			Q.P.	AV.	Q.P.	AV.	Q.P.	AV.	Q.P.	AV.
1	0.25938	0.18	31.75	25.50	31.93	25.68	61.45	51.45	-29.52	-25.77
2	1.36719	0.26	37.41	27.93	37.67	28.19	56.00	46.00	-18.33	-17.81
3	1.88672	0.29	38.88	29.13	39.17	29.42	56.00	46.00	-16.83	-16.58
4	2.70703	0.33	40.61	29.53	40.94	29.86	56.00	46.00	-15.06	-16.14
5	4.28906	0.42	42.19	29.84	42.61	30.26	56.00	46.00	-13.39	-15.74
6	6.49219	0.53	38.30	31.94	38.83	32.47	60.00	50.00	-21.17	-17.53

REMARKS:

1. Q.P. and AV. are abbreviations of quasi-peak and average individually.
2. The emission levels of other frequencies were very low against the limit.
3. Margin value = Emission level - Limit value
4. Correction factor = Insertion loss + Cable loss
5. Emission Level = Correction Factor + Reading Value.

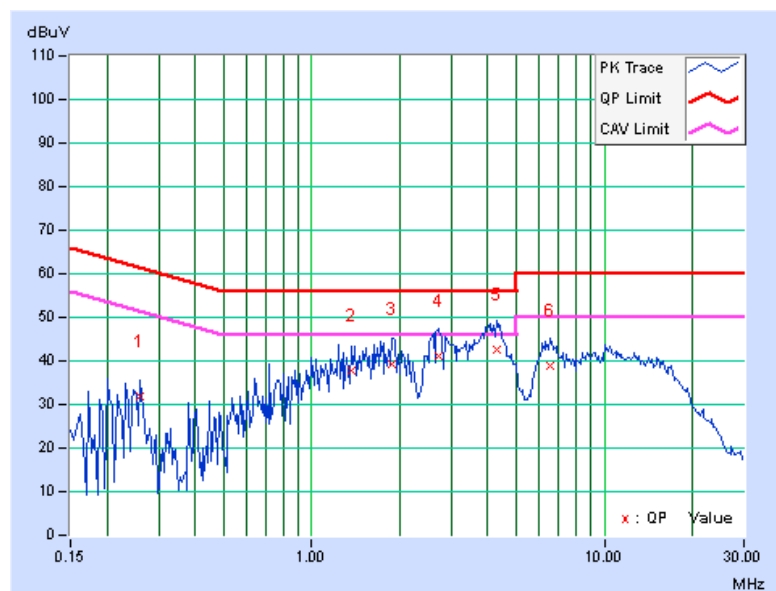



A D T

PHASE	Line 2	6dB BANDWIDTH	9kHz
CHANNEL	Channel 48	TEST MODE	A

No	Freq. [MHz]	Corr. Factor (dB)	Reading Value		Emission Level		Limit		Margin	
			[dB (uV)]		[dB (uV)]		[dB (uV)]		(dB)	
			Q.P.	AV.	Q.P.	AV.	Q.P.	AV.	Q.P.	AV.
1	0.38828	0.24	39.32	29.70	39.56	29.94	58.10	48.10	-18.54	-18.16
2	0.53281	0.24	36.91	32.16	37.15	32.40	56.00	46.00	-18.85	-13.60
3	1.54688	0.27	35.54	25.50	35.81	25.77	56.00	46.00	-20.19	-20.23
4	3.03516	0.33	36.14	26.60	36.47	26.93	56.00	46.00	-19.53	-19.07
5	4.34766	0.39	39.62	27.72	40.01	28.11	56.00	46.00	-15.99	-17.89
6	6.39453	0.47	41.19	35.85	41.66	36.32	60.00	50.00	-18.34	-13.68

REMARKS:

1. Q.P. and AV. are abbreviations of quasi-peak and average individually.
2. The emission levels of other frequencies were very low against the limit.
3. Margin value = Emission level - Limit value
4. Correction factor = Insertion loss + Cable loss
5. Emission Level = Correction Factor + Reading Value.

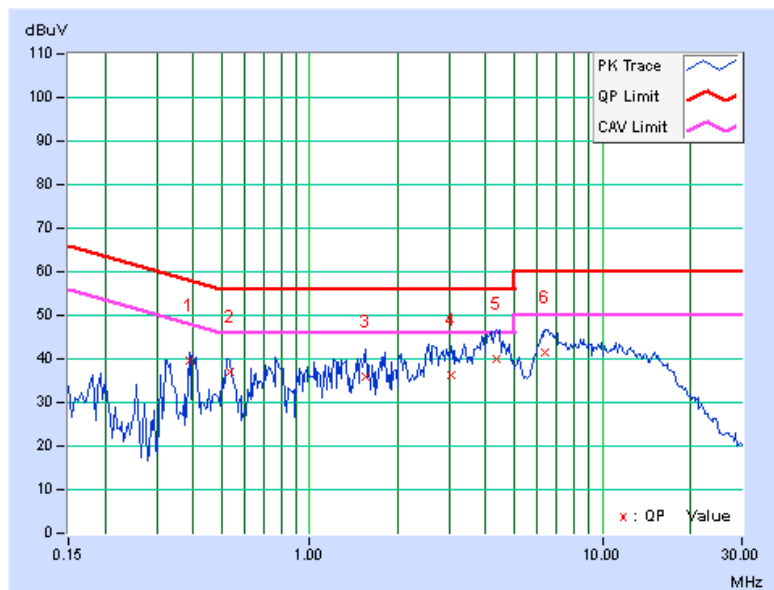



A D T

PHASE	Line 1	6dB BANDWIDTH	9kHz
CHANNEL	Channel 48	TEST MODE	B

No	Freq. [MHz]	Corr. Factor (dB)	Reading Value		Emission Level		Limit		Margin	
			[dB (uV)]		[dB (uV)]		[dB (uV)]		(dB)	
			Q.P.	AV.	Q.P.	AV.	Q.P.	AV.	Q.P.	AV.
1	0.15000	0.16	50.25	30.65	50.41	30.81	66.00	56.00	-15.59	-25.19
2	0.18125	0.16	50.78	35.81	50.94	35.97	64.43	54.43	-13.49	-18.46
3	0.23594	0.17	42.32	30.14	42.49	30.31	62.24	52.24	-19.75	-21.93
4	0.32578	0.20	36.59	24.14	36.79	24.34	59.56	49.56	-22.76	-25.21
5	0.50547	0.23	32.68	22.95	32.91	23.18	56.00	46.00	-23.09	-22.82
6	19.48438	1.20	29.12	23.41	30.32	24.61	60.00	50.00	-29.68	-25.39

REMARKS:

1. Q.P. and AV. are abbreviations of quasi-peak and average individually.
2. The emission levels of other frequencies were very low against the limit.
3. Margin value = Emission level - Limit value
4. Correction factor = Insertion loss + Cable loss
5. Emission Level = Correction Factor + Reading Value.

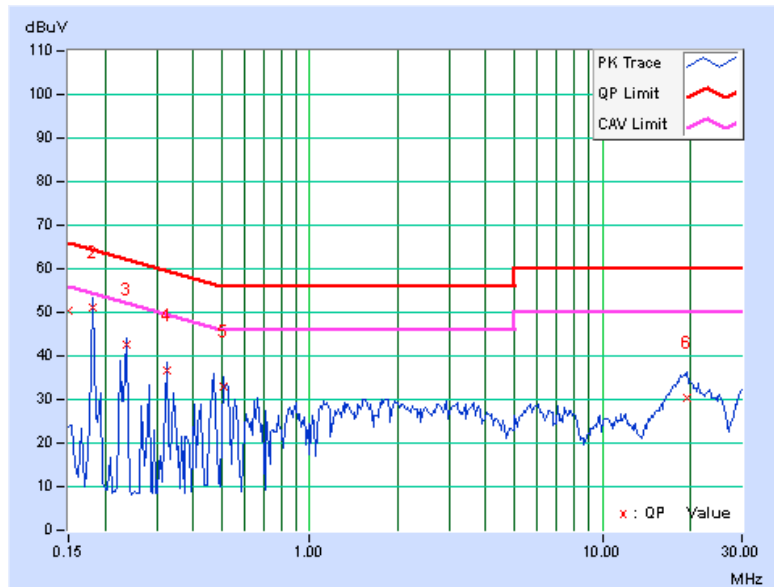



A D T

PHASE	Line 2	6dB BANDWIDTH	9kHz
CHANNEL	Channel 48	TEST MODE	B

No	Freq. [MHz]	Corr. Factor (dB)	Reading Value		Emission Level		Limit		Margin	
			[dB (uV)]		[dB (uV)]		[dB (uV)]		(dB)	
			Q.P.	AV.	Q.P.	AV.	Q.P.	AV.	Q.P.	AV.
1	0.15000	0.16	50.62	30.41	50.78	30.57	66.00	56.00	-15.22	-25.43
2	0.18906	0.17	50.73	37.36	50.90	37.53	64.08	54.08	-13.18	-16.55
3	0.23203	0.18	43.41	31.23	43.59	31.41	62.38	52.38	-18.79	-20.97
4	0.27500	0.20	37.70	28.45	37.90	28.65	60.97	50.97	-23.07	-22.32
5	0.49766	0.24	33.16	21.87	33.40	22.11	56.04	46.04	-22.64	-23.93
6	18.40234	0.88	30.65	25.05	31.53	25.93	60.00	50.00	-28.47	-24.07

REMARKS:

1. Q.P. and AV. are abbreviations of quasi-peak and average individually.
2. The emission levels of other frequencies were very low against the limit.
3. Margin value = Emission level - Limit value
4. Correction factor = Insertion loss + Cable loss
5. Emission Level = Correction Factor + Reading Value.

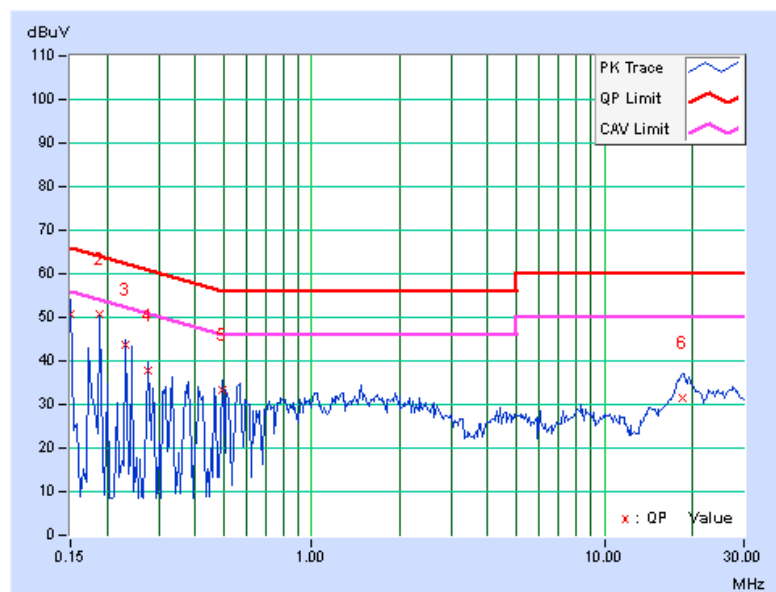



A D T

PHASE	Line 1	6dB BANDWIDTH	9kHz
CHANNEL	Channel 48	TEST MODE	C

No	Freq. [MHz]	Corr. Factor (dB)	Reading Value		Emission Level		Limit		Margin	
			[dB (uV)]		[dB (uV)]		[dB (uV)]		(dB)	
			Q.P.	AV.	Q.P.	AV.	Q.P.	AV.	Q.P.	AV.
1	0.15000	0.16	39.76	33.28	39.92	33.44	66.00	56.00	-26.08	-22.56
2	0.18125	0.16	52.04	17.48	52.20	17.64	64.43	54.43	-12.23	-36.79
3	0.19687	0.16	48.33	34.64	48.49	34.80	63.74	53.74	-15.25	-18.94
4	0.48984	0.23	39.24	38.02	39.47	38.25	56.17	46.17	-16.70	-7.92
5	1.70031	0.28	35.48	31.91	35.76	32.19	56.00	46.00	-20.24	-13.81
6	12.39453	0.84	31.22	26.04	32.06	26.88	60.00	50.00	-27.94	-23.12

REMARKS:

1. Q.P. and AV. are abbreviations of quasi-peak and average individually.
2. The emission levels of other frequencies were very low against the limit.
3. Margin value = Emission level - Limit value
4. Correction factor = Insertion loss + Cable loss
5. Emission Level = Correction Factor + Reading Value.

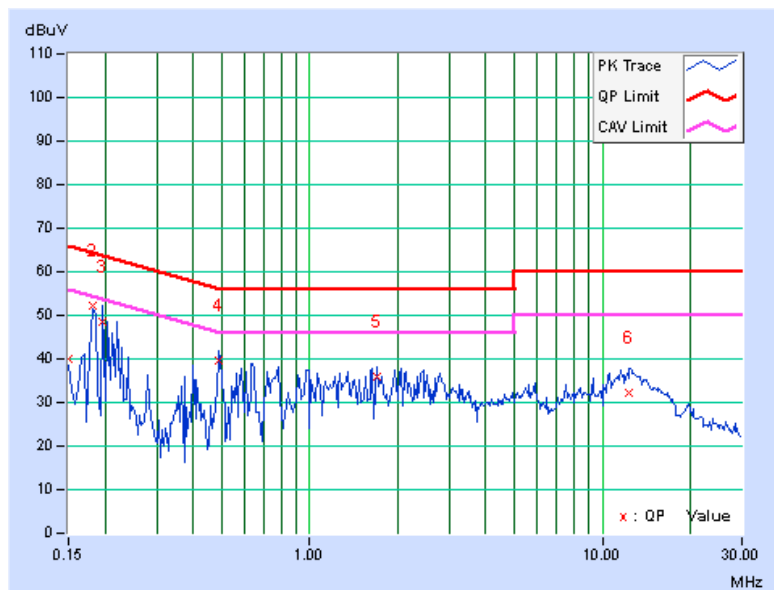



A D T

PHASE	Line 2	6dB BANDWIDTH	9kHz
CHANNEL	Channel 48	TEST MODE	C

No	Freq. [MHz]	Corr. Factor (dB)	Reading Value		Emission Level		Limit		Margin	
			[dB (uV)]		[dB (uV)]		[dB (uV)]		(dB)	
			Q.P.	AV.	Q.P.	AV.	Q.P.	AV.	Q.P.	AV.
1	0.15000	0.16	43.22	32.80	43.38	32.96	66.00	56.00	-22.62	-23.04
2	0.18516	0.17	51.49	38.58	51.66	38.75	64.25	54.25	-12.59	-15.50
3	0.20859	0.17	45.31	32.93	45.48	33.10	63.26	53.26	-17.78	-20.16
4	0.49375	0.24	38.74	37.56	38.98	37.80	56.10	46.10	-17.12	-8.30
5	2.77734	0.32	31.36	24.28	31.68	24.60	56.00	46.00	-24.32	-21.40
6	11.99219	0.66	31.69	26.17	32.35	26.83	60.00	50.00	-27.65	-23.17

REMARKS:

1. Q.P. and AV. are abbreviations of quasi-peak and average individually.
2. The emission levels of other frequencies were very low against the limit.
3. Margin value = Emission level - Limit value
4. Correction factor = Insertion loss + Cable loss
5. Emission Level = Correction Factor + Reading Value.

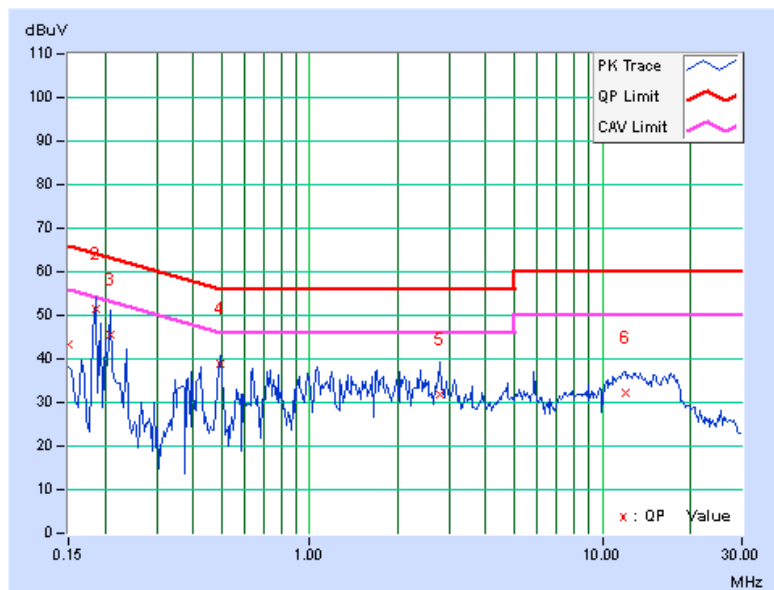



A D T

PHASE	Line 1	6dB BANDWIDTH	9kHz
CHANNEL	Channel 100	TEST MODE	A

No	Freq. [MHz]	Corr. Factor (dB)	Reading Value		Emission Level		Limit		Margin	
			[dB (uV)]		[dB (uV)]		[dB (uV)]		(dB)	
			Q.P.	AV.	Q.P.	AV.	Q.P.	AV.	Q.P.	AV.
1	0.25156	0.18	33.04	25.45	33.22	25.63	61.71	51.71	-28.49	-26.08
2	1.60938	0.27	37.83	28.60	38.10	28.87	56.00	46.00	-17.90	-17.13
3	1.95703	0.29	38.68	28.67	38.97	28.96	56.00	46.00	-17.03	-17.04
4	3.05078	0.35	39.47	27.22	39.82	27.57	56.00	46.00	-16.18	-18.43
5	4.22266	0.41	42.76	29.90	43.17	30.31	56.00	46.00	-12.83	-15.69
6	6.32813	0.52	38.14	31.88	38.66	32.40	60.00	50.00	-21.34	-17.60

REMARKS:

1. Q.P. and AV. are abbreviations of quasi-peak and average individually.
2. The emission levels of other frequencies were very low against the limit.
3. Margin value = Emission level - Limit value
4. Correction factor = Insertion loss + Cable loss
5. Emission Level = Correction Factor + Reading Value.

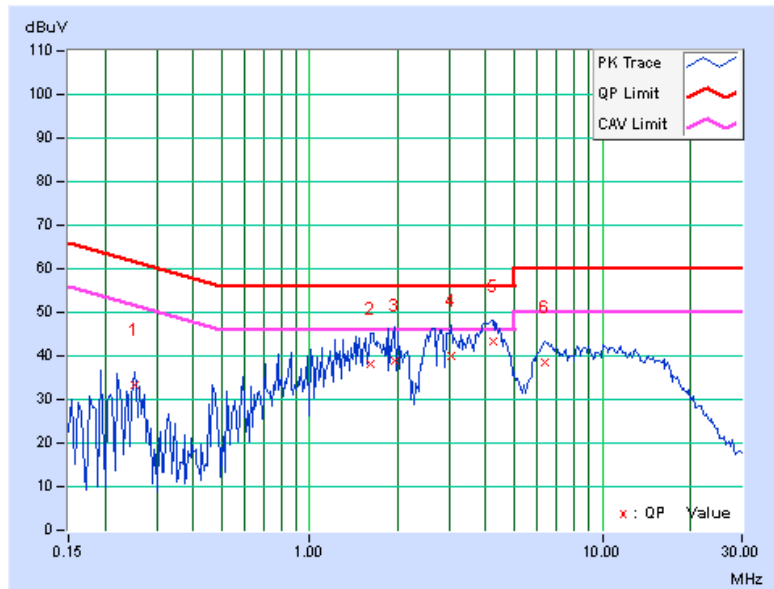



A D T

PHASE	Line 2	6dB BANDWIDTH	9kHz
CHANNEL	Channel 100	TEST MODE	A

No	Freq. [MHz]	Corr. Factor (dB)	Reading Value		Emission Level		Limit		Margin	
			[dB (uV)]		[dB (uV)]		[dB (uV)]		(dB)	
			Q.P.	AV.	Q.P.	AV.	Q.P.	AV.	Q.P.	AV.
1	0.39953	0.24	39.66	34.64	39.90	34.88	57.86	47.86	-17.96	-12.98
2	0.53075	0.24	38.30	33.21	38.54	33.45	56.00	46.00	-17.46	-12.55
3	2.76563	0.32	37.83	27.23	38.15	27.55	56.00	46.00	-17.85	-18.45
4	4.29297	0.39	39.84	27.21	40.23	27.60	56.00	46.00	-15.77	-18.40
5	6.60938	0.48	41.13	35.80	41.61	36.28	60.00	50.00	-18.39	-13.72
6	8.73828	0.55	38.29	32.27	38.84	32.82	60.00	50.00	-21.16	-17.18

REMARKS:

1. Q.P. and AV. are abbreviations of quasi-peak and average individually.
2. The emission levels of other frequencies were very low against the limit.
3. Margin value = Emission level - Limit value
4. Correction factor = Insertion loss + Cable loss
5. Emission Level = Correction Factor + Reading Value.

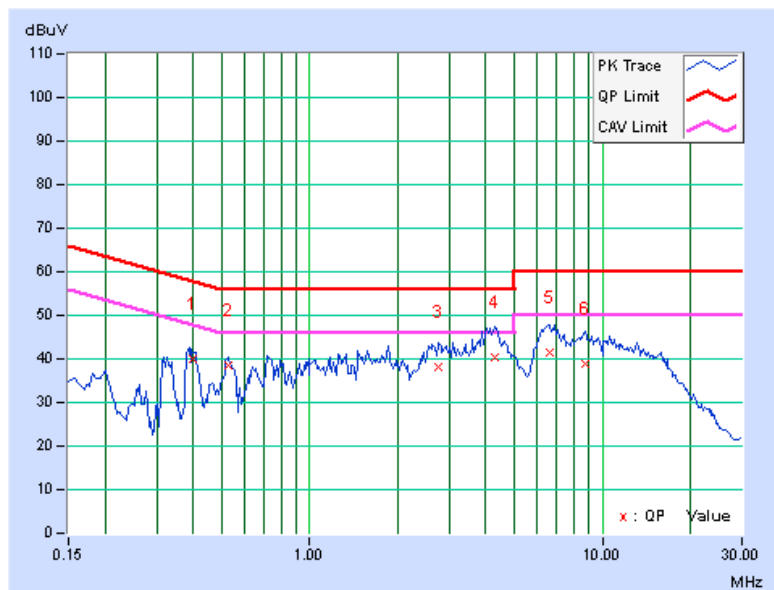



A D T

PHASE	Line 1	6dB BANDWIDTH	9kHz
CHANNEL	Channel 100	TEST MODE	B

No	Freq. [MHz]	Corr. Factor (dB)	Reading Value		Emission Level		Limit		Margin	
			[dB (uV)]		[dB (uV)]		[dB (uV)]		(dB)	
			Q.P.	AV.	Q.P.	AV.	Q.P.	AV.	Q.P.	AV.
1	0.15000	0.16	51.04	30.43	51.20	30.59	66.00	56.00	-14.80	-25.41
2	0.18125	0.16	49.95	35.19	50.11	35.35	64.43	54.43	-14.32	-19.08
3	0.28281	0.19	39.42	24.43	39.61	24.62	60.73	50.73	-21.12	-26.11
4	0.32228	0.20	36.49	22.65	36.69	22.85	59.65	49.65	-22.96	-26.80
5	0.52500	0.23	31.80	20.10	32.03	20.33	56.00	46.00	-23.97	-25.67
6	18.53906	1.15	29.38	23.92	30.53	25.07	60.00	50.00	-29.47	-24.93

REMARKS:

1. Q.P. and AV. are abbreviations of quasi-peak and average individually.
2. The emission levels of other frequencies were very low against the limit.
3. Margin value = Emission level - Limit value
4. Correction factor = Insertion loss + Cable loss
5. Emission Level = Correction Factor + Reading Value.

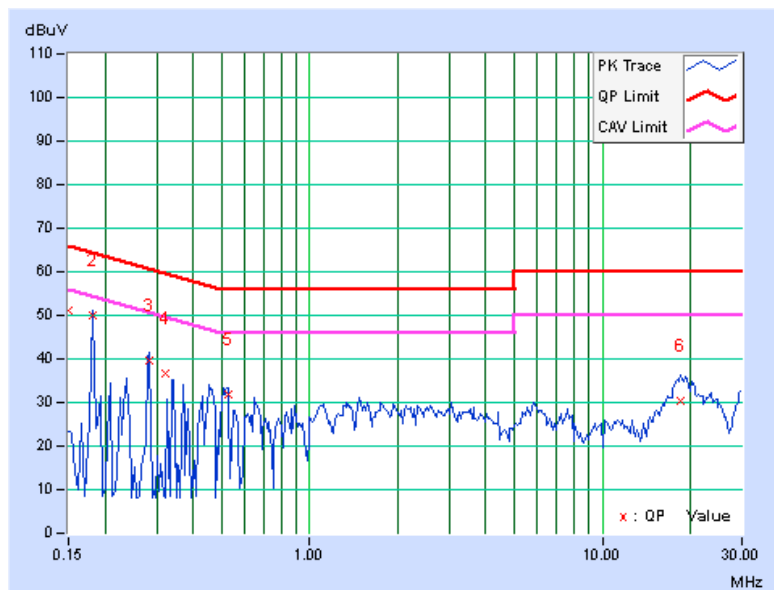

PHASE	Line 2	6dB BANDWIDTH	9kHz
CHANNEL	Channel 100	TEST MODE	B

No	Freq. [MHz]	Corr. Factor (dB)	Reading Value		Emission Level		Limit		Margin	
			[dB (uV)]		[dB (uV)]		[dB (uV)]		(dB)	
			Q.P.	AV.	Q.P.	AV.	Q.P.	AV.	Q.P.	AV.
1	0.15000	0.16	51.49	30.79	51.65	30.95	66.00	56.00	-14.35	-25.05
2	0.18788	0.17	50.52	37.90	50.69	38.07	64.13	54.13	-13.44	-16.06
3	0.22422	0.18	42.55	25.51	42.73	25.69	62.66	52.66	-19.93	-26.97
4	0.49766	0.24	33.26	21.43	33.50	21.67	56.04	46.04	-22.54	-24.37
5	0.56406	0.24	33.02	24.73	33.26	24.97	56.00	46.00	-22.74	-21.03
6	19.16016	0.90	30.75	24.97	31.65	25.87	60.00	50.00	-28.35	-24.13

REMARKS:

1. Q.P. and AV. are abbreviations of quasi-peak and average individually.
2. The emission levels of other frequencies were very low against the limit.
3. Margin value = Emission level - Limit value
4. Correction factor = Insertion loss + Cable loss
5. Emission Level = Correction Factor + Reading Value.

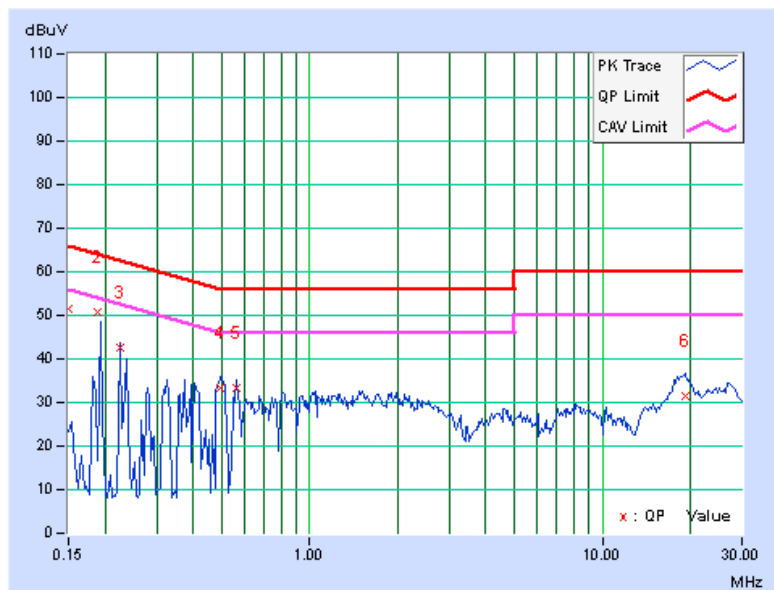

PHASE	Line 1	6dB BANDWIDTH	9kHz
CHANNEL	Channel 100	TEST MODE	C

No	Freq. [MHz]	Corr. Factor (dB)	Reading Value		Emission Level		Limit		Margin	
			[dB (uV)]		[dB (uV)]		[dB (uV)]		(dB)	
			Q.P.	AV.	Q.P.	AV.	Q.P.	AV.	Q.P.	AV.
1	0.15000	0.16	47.79	33.68	47.95	33.84	66.00	56.00	-18.05	-22.16
2	0.18516	0.16	51.15	38.22	51.31	38.38	64.25	54.25	-12.94	-15.87
3	0.20469	0.16	46.30	33.09	46.46	33.25	63.42	53.42	-16.96	-20.17
4	0.49239	0.23	39.66	39.04	39.89	39.27	56.13	46.13	-16.23	-6.85
5	1.05469	0.25	34.12	30.26	34.37	30.51	56.00	46.00	-21.63	-15.49
6	13.22266	0.88	30.01	24.71	30.89	25.59	60.00	50.00	-29.11	-24.41

REMARKS:

1. Q.P. and AV. are abbreviations of quasi-peak and average individually.
2. The emission levels of other frequencies were very low against the limit.
3. Margin value = Emission level - Limit value
4. Correction factor = Insertion loss + Cable loss
5. Emission Level = Correction Factor + Reading Value.

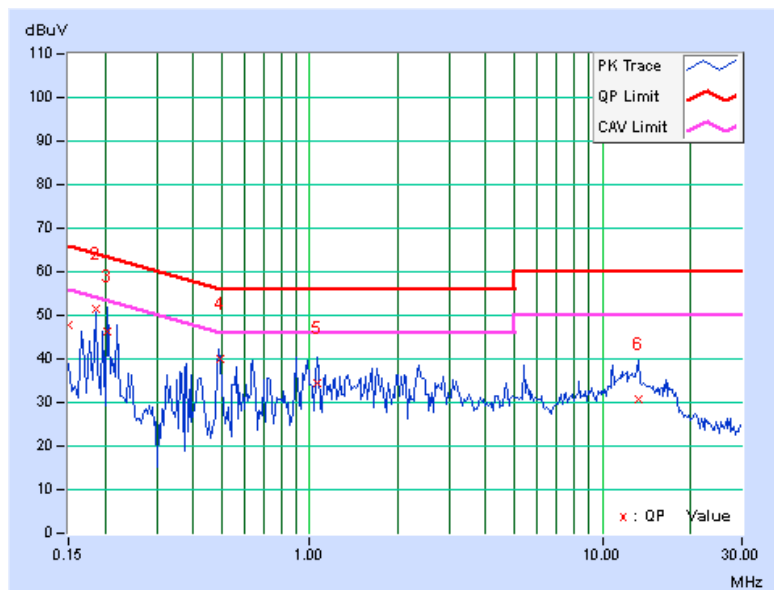



A D T

PHASE	Line 2	6dB BANDWIDTH	9kHz
CHANNEL	Channel 100	TEST MODE	C

No	Freq. [MHz]	Corr. Factor (dB)	Reading Value		Emission Level		Limit		Margin	
			[dB (uV)]		[dB (uV)]		[dB (uV)]		(dB)	
			Q.P.	AV.	Q.P.	AV.	Q.P.	AV.	Q.P.	AV.
1	0.15000	0.16	43.26	33.16	43.42	33.32	66.00	56.00	-22.58	-22.68
2	0.19297	0.17	49.10	35.20	49.27	35.37	63.91	53.91	-14.64	-18.54
3	0.22812	0.18	41.50	27.33	41.68	27.51	62.52	52.52	-20.84	-25.01
4	0.49112	0.24	38.60	37.90	38.84	38.14	56.15	46.15	-17.31	-8.01
5	1.30078	0.26	33.27	25.75	33.53	26.01	56.00	46.00	-22.47	-19.99
6	11.89453	0.66	31.77	26.48	32.43	27.14	60.00	50.00	-27.57	-22.86

REMARKS:

1. Q.P. and AV. are abbreviations of quasi-peak and average individually.
2. The emission levels of other frequencies were very low against the limit.
3. Margin value = Emission level - Limit value
4. Correction factor = Insertion loss + Cable loss
5. Emission Level = Correction Factor + Reading Value.

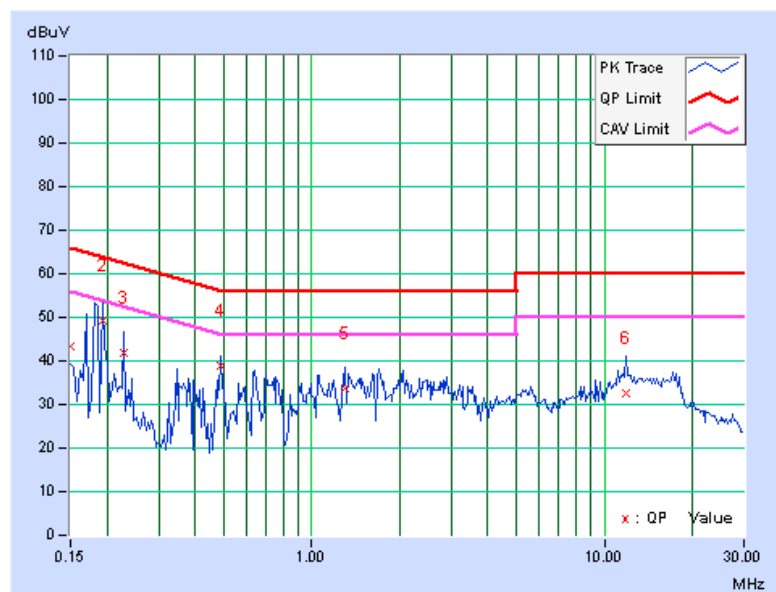

4.3 PEAK TRANSMIT POWER MEASUREMENT

4.3.1 LIMITS OF PEAK TRANSMIT POWER MEASUREMENT

FREQUENCY BAND	LIMIT
5.150 ~ 5.250GHz	The lesser of 50mW (17dBm) or 4dBm + 10logB
5.250 ~ 5.350GHz	The lesser of 250mW (24dBm) or 11dBm + 10logB
5.470 ~ 5.725GHz	The lesser of 250mW (24dBm) or 11dBm + 10logB

NOTE: Where B is the 26dB emission bandwidth in MHz.

4.3.2 TEST SETUP

FOR POWER OUTPUT MEASUREMENT

For 802.11a, 802.11n (20MHz), 802.11n (40MHz)

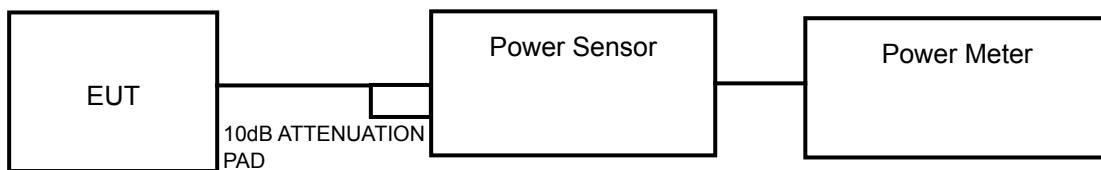

For 802.11ac (80MHz)



FOR 26dB BANDWIDTH

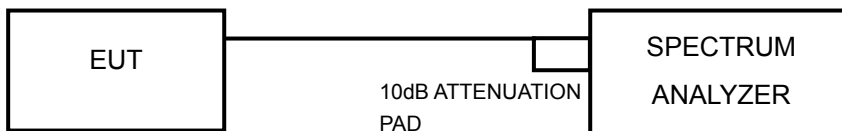

4.3.3 TEST INSTRUMENTS

Refer to section 4.1.3 to get information of above instrument.

4.3.4 TEST PROCEDURE

FOR AVERAGE POWER MEASUREMENT

For 802.11a, 802.11n (20MHz), 802.11n (40MHz)

Method PM is used to perform output power measurement, trigger and gating function of wide band power meter is enabled to measure max output power of TX on burst. Duty factor is not added to measured value.

For 802.11ac (80MHz)

- 1) Set span to encompass the entire 26 dB EBW (or, alternatively, the entire 99% occupied bandwidth) of the signal.
- 2) Set sweep trigger to “free run”.
- 3) Set RBW = 1 MHz.
- 4) Set VBW \geq 3 MHz
- 5) Number of points in sweep \geq 2 Span / RBW.
- 6) Sweep time \leq (number of points in sweep) * T
- 7) Detector = RMS.
- 8) Trace mode = max hold.
- 9) Allow max hold to run for at least 60 seconds, or longer as needed to allow the trace to stabilize.

FOR 26dB BANDWIDTH

- 1) Set RBW = approximately 1% of the emission bandwidth.
- 2) Set the VBW > RBW.
- 3) Detector = Peak.
- 4) Trace mode = max hold.
- 5) Measure the maximum width of the emission that is 26 dB down from the peak of the emission. Compare this with the RBW setting of the analyzer. Readjust RBW and repeat measurement as needed until the RBW/EBW ratio is approximately 1%.

4.3.5 DEVIATION FROM TEST STANDARD

No deviation.

4.3.6 EUT OPERATING CONDITIONS

The software provided by client to enable the EUT under transmission condition continuously at specific channel frequencies individually.

4.3.7 TEST RESULTS

POWER OUTPUT:

802.11a

CHANNEL	CHANNEL FREQUENCY (MHz)	AVERAGE POWER (mW)	AVERAGE POWER (dBm)	POWER LIMIT (dBm)	PASS/FAIL
36	5180	14.894	11.73	17	PASS
40	5200	14.322	11.56	16.99	PASS
48	5240	15.560	11.92	17	PASS
52	5260	15.205	11.82	24	PASS
60	5300	14.825	11.71	24	PASS
64	5320	14.962	11.75	24	PASS
100	5500	15.382	11.87	24	PASS
116	5580	15.382	11.87	24	PASS
140	5700	14.962	11.75	24	PASS

NOTE:

1. $4\text{dBm} + 10\log(20.35) = 17.09\text{dBm} > 17\text{dBm}$.
2. $4\text{dBm} + 10\log(19.89) = 16.99\text{dBm} < 17\text{dBm}$.
3. $4\text{dBm} + 10\log(20.21) = 17.06\text{dBm} > 17\text{dBm}$.
4. $11\text{dBm} + 10\log(20.06) = 24.02\text{dBm} > 24\text{dBm}$.
5. $11\text{dBm} + 10\log(20.27) = 24.07\text{dBm} > 24\text{dBm}$.
6. $11\text{dBm} + 10\log(20.10) = 24.03\text{dBm} > 24\text{dBm}$.
7. $11\text{dBm} + 10\log(20.43) = 24.10\text{dBm} > 24\text{dBm}$.
8. $11\text{dBm} + 10\log(20.74) = 24.17\text{dBm} > 24\text{dBm}$.
9. $11\text{dBm} + 10\log(20.21) = 24.06\text{dBm} > 24\text{dBm}$.



802.11n (20MHz)

CHANNEL	CHANNEL FREQUENCY (MHz)	AVERAGE POWER (mW)	AVERAGE POWER (dBm)	POWER LIMIT (dBm)	PASS/FAIL
36	5180	12.618	11.01	17	PASS
40	5200	12.445	10.95	17	PASS
48	5240	12.023	10.80	17	PASS
52	5260	11.995	10.79	24	PASS
60	5300	12.246	10.88	24	PASS
64	5320	11.776	10.71	24	PASS
100	5500	15.382	11.87	24	PASS
116	5580	15.382	11.87	24	PASS
140	5700	14.962	11.75	24	PASS

NOTE:

1. $4\text{dBm} + 10\log(20.60) = 17.14\text{dBm} > 17\text{dBm}$.
2. $4\text{dBm} + 10\log(21.00) = 17.22\text{dBm} > 17\text{dBm}$.
3. $4\text{dBm} + 10\log(20.77) = 17.17\text{dBm} > 17\text{dBm}$.
4. $11\text{dBm} + 10\log(20.78) = 24.18\text{dBm} > 24\text{dBm}$.
5. $11\text{dBm} + 10\log(20.77) = 24.17\text{dBm} > 24\text{dBm}$.
6. $11\text{dBm} + 10\log(20.85) = 24.19\text{dBm} > 24\text{dBm}$.
7. $11\text{dBm} + 10\log(20.60) = 24.14\text{dBm} > 24\text{dBm}$.
8. $11\text{dBm} + 10\log(20.57) = 24.13\text{dBm} > 24\text{dBm}$.
9. $11\text{dBm} + 10\log(20.92) = 24.21\text{dBm} > 24\text{dBm}$.

802.11n (40MHz)

CHANNEL	CHANNEL FREQUENCY (MHz)	AVERAGE POWER (mW)	AVERAGE POWER (dBm)	POWER LIMIT (dBm)	PASS/FAIL
38	5190	11.402	10.57	17	PASS
46	5230	11.272	10.52	17	PASS
54	5270	11.015	10.42	24	PASS
62	5310	10.186	10.08	24	PASS
102	5510	13.677	11.36	24	PASS
110	5550	13.274	11.23	24	PASS
134	5670	13.032	11.15	24	PASS

NOTE:

1. $4\text{dBm} + 10\log(44.33) = 20.47\text{dBm} > 17\text{dBm}$.
2. $4\text{dBm} + 10\log(44.97) = 20.53\text{dBm} > 17\text{dBm}$.
3. $11\text{dBm} + 10\log(44.07) = 27.44\text{dBm} > 24\text{dBm}$.
4. $11\text{dBm} + 10\log(44.75) = 27.51\text{dBm} > 24\text{dBm}$.
5. $11\text{dBm} + 10\log(45.30) = 27.56\text{dBm} > 24\text{dBm}$.
6. $11\text{dBm} + 10\log(44.95) = 27.53\text{dBm} > 24\text{dBm}$.
7. $11\text{dBm} + 10\log(45.11) = 27.54\text{dBm} > 24\text{dBm}$.

802.11ac (80MHz)

CHANNEL	CHANNEL FREQUENCY (MHz)	AVERAGE POWER (mW)	AVERAGE POWER (dBm)	POWER LIMIT (dBm)	PASS/FAIL
42	5210	14.997	11.76	17	PASS
58	5290	14.757	11.69	24	PASS
106	5530	14.093	11.49	24	PASS

NOTE:

1. $4\text{dBm} + 10\log(84.13) = 23.25\text{dBm} > 17\text{dBm}$.
2. $11\text{dBm} + 10\log(84.10) = 30.25\text{dBm} > 24\text{dBm}$.
3. $11\text{dBm} + 10\log(84.20) = 30.25\text{dBm} > 24\text{dBm}$.



26dB BANDWIDTH:

802.11a

CHANNEL	CHANNEL FREQUENCY (MHz)	26dBc BANDWIDTH (MHz)	PASS / FAIL
36	5180	20.35	PASS
40	5200	19.89	PASS
48	5240	20.21	PASS
52	5260	20.06	PASS
60	5300	20.27	PASS
64	5320	20.10	PASS
100	5500	20.43	PASS
116	5580	20.74	PASS
140	5700	20.21	PASS

802.11n (20MHz)

CHANNEL	CHANNEL FREQUENCY (MHz)	26dBc BANDWIDTH (MHz)	PASS / FAIL
36	5180	20.60	PASS
40	5200	21.00	PASS
48	5240	20.77	PASS
52	5260	20.78	PASS
60	5300	20.77	PASS
64	5320	20.85	PASS
100	5500	20.60	PASS
116	5580	20.57	PASS
140	5700	20.92	PASS



A D T

802.11n (40MHz)

CHANNEL	CHANNEL FREQUENCY (MHz)	26dBc BANDWIDTH (MHz)	PASS / FAIL
38	5190	44.33	PASS
46	5230	44.97	PASS
54	5270	44.07	PASS
62	5310	44.75	PASS
102	5510	45.30	PASS
110	5550	44.95	PASS
134	5670	45.11	PASS

802.11ac (80MHz)

CHANNEL	CHANNEL FREQUENCY (MHz)	26dBc BANDWIDTH (MHz)	PASS / FAIL
42	5210	84.13	PASS
58	5290	84.10	PASS
106	5530	84.20	PASS

SPECTRUM PLOT OF WORST VALUE

802.11a

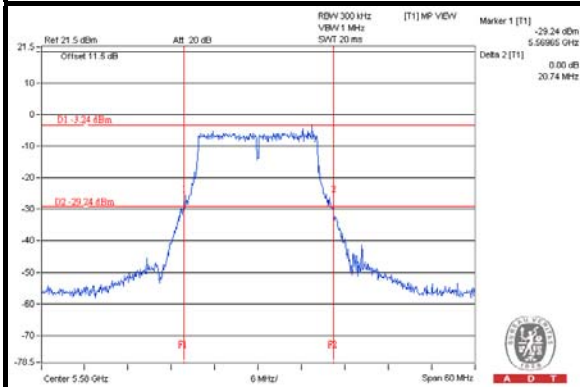

802.11n (20MHz)

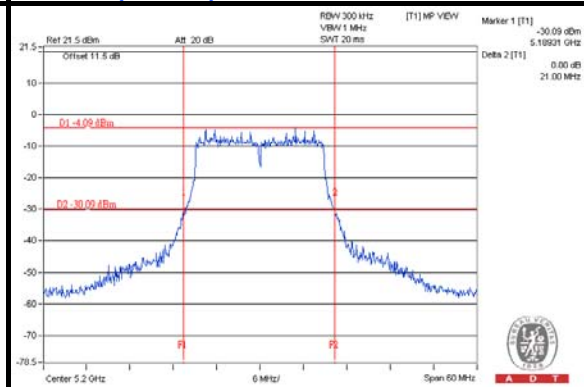

802.11n (40MHz)

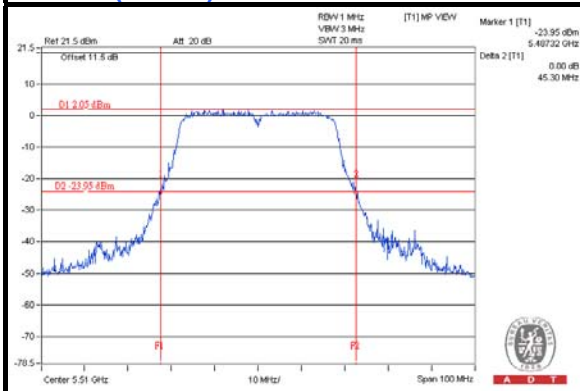

802.11ac (80MHz)

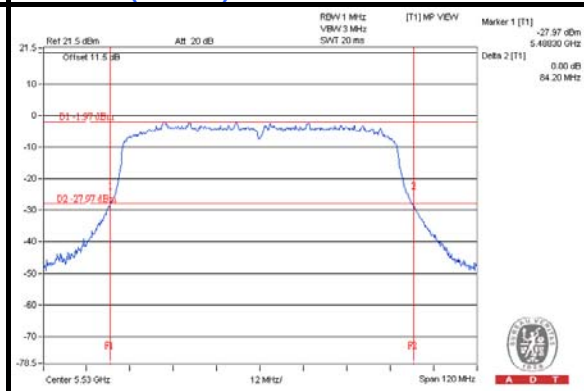

4.4 PEAK POWER SPECTRAL DENSITY MEASUREMENT

4.4.1 LIMITS OF PEAK POWER SPECTRAL DENSITY MEASUREMENT

FREQUENCY BAND	LIMIT
5.150 ~ 5.250GHz	4dBm
5.250 ~ 5.350GHz	11dBm
5.470 ~ 5.725GHz	11dBm

4.4.2 TEST SETUP



4.4.3 TEST INSTRUMENTS

Refer to section 4.1.3 to get information of above instrument.

4.4.4 TEST PROCEDURES

802.11a, 802.11n (20MHz), 802.11n (40MHz):

Using method SA-1

- 1) Set span to encompass the entire emission bandwidth (EBW) of the signal.
- 2) Set RBW = 30 KHz, Set VBW \geq 1 MHz, Detector = RMS.
- 3) Set Channel power measure = 1MHz.
- 4) Sweep time = auto, trigger set to "free run".
- 5) Trace average at least 100 traces in power averaging mode.
- 6) Record the max value.

802.11ac (80MHz):

Using method SA-2

- 1) Set span to encompass the entire emission bandwidth (EBW) of the signal.
- 2) Set RBW = 30 KHz, Set VBW \geq 1 MHz, Detector = RMS.
- 3) Set Channel power measure = 1MHz.
- 4) Sweep time = auto, trigger set to "free run".
- 5) Trace average at least 100 traces in power averaging mode.
- 6) Record the max value and add $10 \log (1/\text{duty cycle})$.

4.4.5 DEVIATION FROM TEST STANDARD

No deviation.

4.4.6 EUT OPERATING CONDITIONS

Same as 4.3.6.

4.4.7 TEST RESULTS

802.11a

CHANNEL	FREQUENCY (MHz)	PSD (dBm)	MAXIMUM LIMIT (dBm)	PASS/FAIL
36	5180	-4.91	4	PASS
40	5200	-5.56	4	PASS
48	5240	-5.26	4	PASS
52	5260	-5.19	11	PASS
60	5300	-5.31	11	PASS
64	5320	-4.95	11	PASS
100	5500	-3.27	11	PASS
116	5580	-3.24	11	PASS
140	5700	-2.58	11	PASS

802.11n (20MHz)

CHANNEL	FREQUENCY (MHz)	PSD (dBm)	MAXIMUM LIMIT (dBm)	PASS/FAIL
36	5180	-5.39	4	PASS
40	5200	-5.68	4	PASS
48	5240	-4.96	4	PASS
52	5260	-4.83	11	PASS
60	5300	-4.97	11	PASS
64	5320	-4.92	11	PASS
100	5500	-3.28	11	PASS
116	5580	-3.40	11	PASS
140	5700	-2.78	11	PASS

802.11n (40MHz)

CHANNEL	FREQUENCY (MHz)	PSD (dBm)	MAXIMUM LIMIT (dBm)	PASS/FAIL
38	5190	-8.35	4	PASS
46	5230	-8.56	4	PASS
54	5270	-8.94	11	PASS
62	5310	-8.60	11	PASS
102	5510	-6.55	11	PASS
110	5550	-6.12	11	PASS
134	5670	-5.98	11	PASS



A D T

802.11ac (80MHz)

CHANNEL	FREQUENCY (MHz)	PSD W/O DUTY FACTOR (dBm)	DUTY FACTOR	PSD WITH DUTY FACTOR (dBm)	MAXIMUM LIMIT (dBm)	PASS/FAIL
42	5210	-11.24	0.17	-11.07	4	PASS
58	5290	-11.62	0.17	-11.45	11	PASS
106	5530	-10.55	0.17	-10.38	11	PASS

NOTE: Refer to section 3.3 for duty cycle spectrum plot.

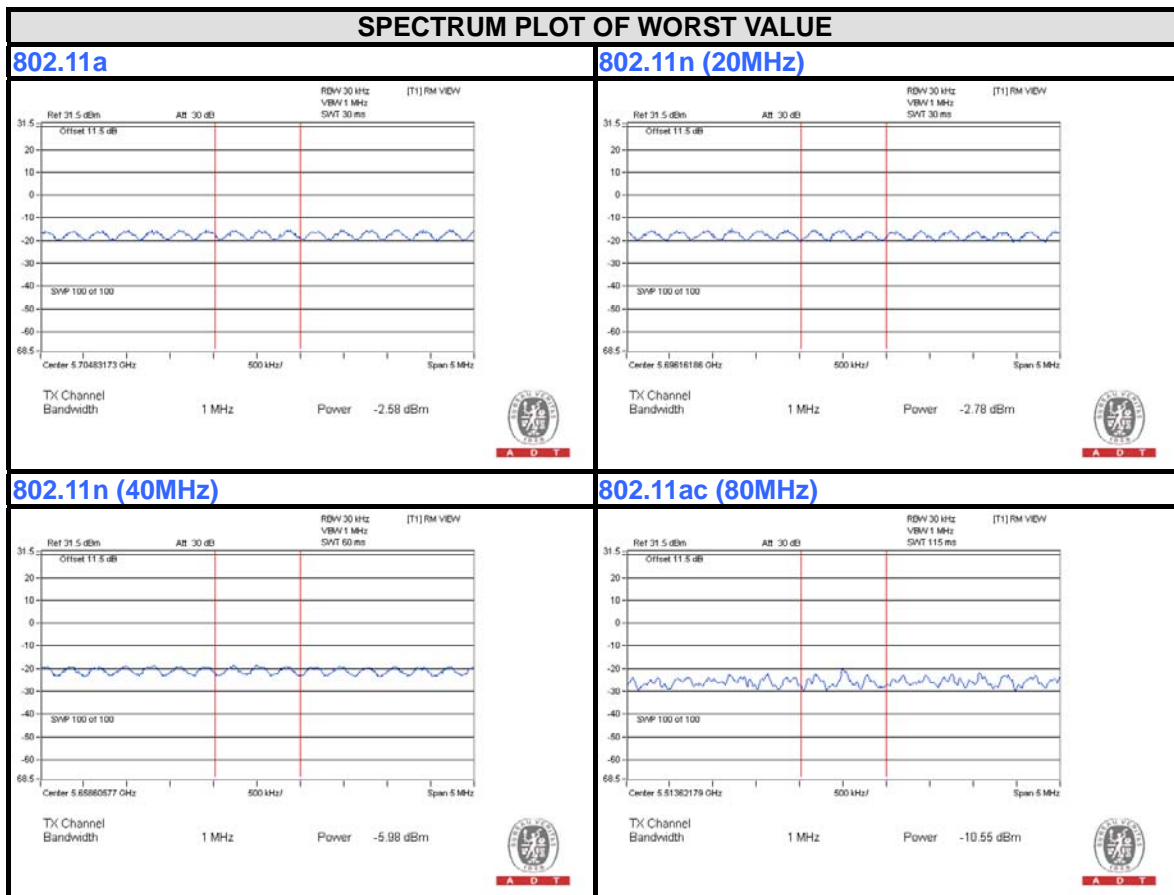

4.5 PEAK POWER EXCURSION MEASUREMENT

4.5.1 LIMITS OF PEAK POWER EXCURSION MEASUREMENT

Shall not exceed 13 dB.

4.5.2 TEST SETUP

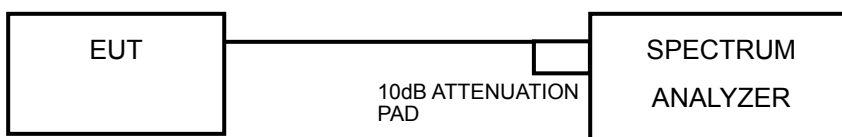

4.5.3 TEST INSTRUMENTS

Refer to section 4.1.3 to get information of above instrument.

4.5.4 TEST PROCEDURE

- 1) Set RBW = 1 MHz, VBW \geq 3 MHz, Detector = peak.
- 2) Trace mode = max-hold. Allow the sweeps to continue until the trace stabilizes.
- 3) Use the peak search function to find the peak of the spectrum.
- 4) Measure the PPSD.
- 5) Compute the ratio of the maximum of the peak-max-hold spectrum to the PPSD.
Find the worst channel and modulation mode as above test procedure, and follow KDB 789033 D01 General UNII Test Procedures v01r03 and repeat step 1 to 5 for final testing of each modulation mode on a single channel (all modulation types) in a single operating band to compliance with the peak excursion requirement.

4.5.5 DEVIATION FROM TEST STANDARD

No deviation.

4.5.6 EUT OPERATING CONDITIONS

Same as 4.2.6



A D T

4.5.7 TEST RESULTS

MODULATION MODE	MODULATION TYPE	CHAN. FREQ. (MHz)	PEAK VALUE (dBm)	PPSD WITHOUT DUTY FACTOR (dBm)	PPSD WITH DUTY FACTOR (dBm)	PEAK EXCURSION (dB)	LIMIT (dB)	PASS /FAIL
802.11a	BPSK	5700	6.34	-2.58	-2.58	8.92	13	PASS
	QPSK		6.93	-2.61	-2.61	9.54	13	PASS
	16QAM		7.37	-2.74	-2.64	10.01	13	PASS
	64QAM		7.86	-3.01	-2.81	10.67	13	PASS
802.11n (20MHz)	BPSK	5700	6.90	-2.78	-2.78	9.68	13	PASS
	QPSK		6.92	-2.98	-2.98	9.90	13	PASS
	16QAM		6.41	-3.13	-3.13	9.54	13	PASS
	64QAM		6.93	-3.06	-2.88	9.81	13	PASS
802.11n (40MHz)	BPSK	5670	2.74	-5.98	-5.98	8.72	13	PASS
	QPSK		3.28	-6.11	-5.98	9.26	13	PASS
	16QAM		3.99	-6.85	-6.63	10.62	13	PASS
	64QAM		4.20	-6.08	-5.67	9.87	13	PASS
802.11ac (80MHz)	BPSK	5530	-1.98	-10.55	-10.38	8.40	13	PASS
	QPSK		-2.57	-10.69	-10.37	7.80	13	PASS
	16QAM		-2.62	-10.32	-9.74	7.12	13	PASS
	64QAM		-2.42	-10.38	-8.83	6.41	13	PASS
	256QAM		-1.70	-10.45	-9.11	7.41	13	PASS

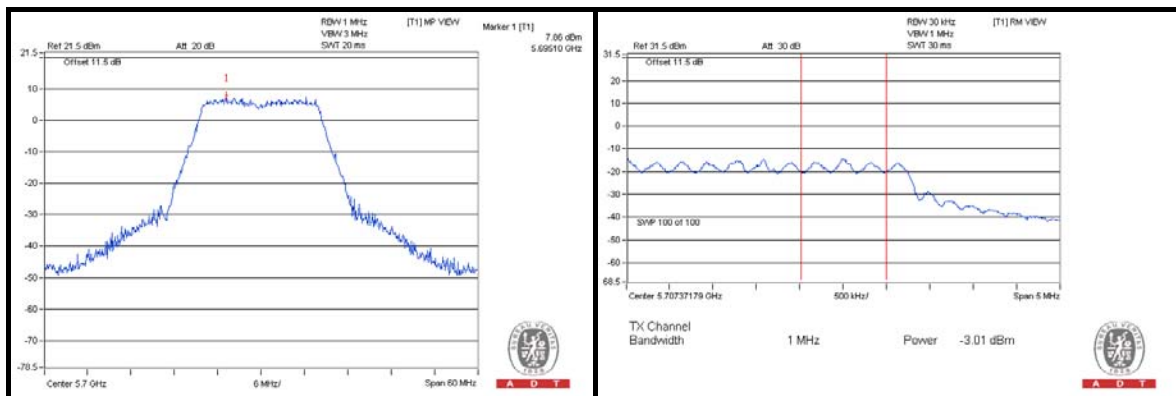

4.6 FREQUENCY STABILITY

4.6.1 LIMITS OF FREQUENCY STABILITY MEASUREMENT

The frequency of the carrier signal shall be maintained within band of operation

4.6.2 TEST SETUP

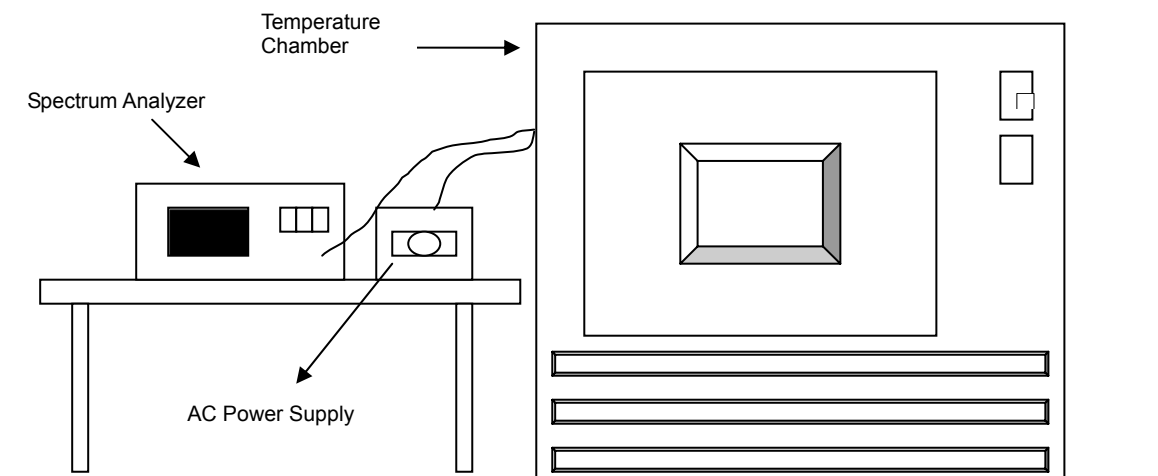

4.6.3 TEST INSTRUMENTS

Refer to section 4.1.3 to get information of above instrument.

4.6.4 TEST PROCEDURE

- a. The EUT was placed inside the environmental test chamber and powered by nominal AC voltage.
- b. Turn the EUT on and couple its output to a spectrum analyzer.
- c. Turn the EUT off and set the chamber to the highest temperature specified.
- d. Allow sufficient time (approximately 30 min) for the temperature of the chamber to stabilize, turn the EUT on and measure the operating frequency after 2, 5, and 10 minutes.
- e. Repeat step 2 and 3 with the temperature chamber set to the lowest temperature.
- f. The test chamber was allowed to stabilize at +20 degree C for a minimum of 30 minutes. The supply voltage was then adjusted on the EUT from 85% to 115% and the frequency record.

4.6.5 DEVIATION FROM TEST STANDARD

No deviation.

4.6.6 EUT OPERATING CONDITION

Set the EUT transmit at un-modulation mode to test frequency stability.

4.6.7 TEST RESULTS

FREQUENCY STABILITY VERSUS TEMP.									
OPERATING FREQUENCY: 5200MHz									
TEMP. (°C)	POWER SUPPLY (Vac)	0 MINUTE		2 MINUTE		5 MINUTE		10 MINUTE	
		Measured Frequency (MHz)	Frequency Drift (%)	Measured Frequency (MHz)	Frequency Drift (%)	Measured Frequency (MHz)	Frequency Drift (%)	Measured Frequency (MHz)	Frequency Drift (%)
55	120	5200.0246	0.00047	5200.0266	0.00051	5200.0258	0.00050	5200.0219	0.00042
50	120	5200.017	0.00033	5200.0142	0.00027	5200.0182	0.00035	5200.0137	0.00026
40	120	5200.0056	0.00011	5200.0044	0.00008	5200.0037	0.00007	5200.0024	0.00005
30	120	5199.9889	-0.00021	5199.9896	-0.00020	5199.986	-0.00027	5199.9896	-0.00020
20	120	5199.9853	-0.00028	5199.9816	-0.00035	5199.9807	-0.00037	5199.9895	-0.00020
10	120	5199.9957	-0.00008	5199.9917	-0.00016	5199.9959	-0.00008	5199.9941	-0.00011
0	120	5199.9739	-0.00050	5199.9751	-0.00048	5199.9773	-0.00044	5199.9742	-0.00050
-10	120	5200.024	0.00046	5200.0231	0.00044	5200.0253	0.00049	5200.0232	0.00045

FREQUENCY STABILITY VERSUS VOLTAGE									
OPERATING FREQUENCY: 5200MHz									
TEMP. (°C)	POWER SUPPLY (Vac)	0 MINUTE		2 MINUTE		5 MINUTE		10 MINUTE	
		Measured Frequency (MHz)	Frequency Drift (%)	Measured Frequency (MHz)	Frequency Drift (%)	Measured Frequency (MHz)	Frequency Drift (%)	Measured Frequency (MHz)	Frequency Drift (%)
20	138	5199.9853	-0.00028	5199.9808	-0.00037	5199.9811	-0.00036	5199.9887	-0.00022
	120	5199.9853	-0.00028	5199.9816	-0.00035	5199.9807	-0.00037	5199.9895	-0.00020
	102	5199.986	-0.00027	5199.9822	-0.00034	5199.9802	-0.00038	5199.9891	-0.00021

5. PHOTOGRAPHS OF THE TEST CONFIGURATION

Please refer to the attached file (Test Setup Photo).



6. INFORMATION ON THE TESTING LABORATORIES

We, Bureau Veritas Consumer Products Services (H.K.) Ltd., Taoyuan Branch, were founded in 1988 to provide our best service in EMC, Radio, Telecom and Safety consultation. Our laboratories are accredited and approved according to ISO/IEC 17025.

If you have any comments, please feel free to contact us at the following:

Linko EMC/RF Lab

Tel: 886-2-26052180

Fax: 886-2-26051924

Hsin Chu EMC/RF Lab

Tel: 886-3-5935343

Fax: 886-3-5935342

Hwa Ya EMC/RF/Safety/Telecom Lab

Tel: 886-3-3183232

Fax: 886-3-3270892

Email: service.adt@tw.bureauveritas.com

Web Site: www.bureauveritas-adt.com

The address and road map of all our labs can be found in our web site also.

7. APPENDIX A – MODIFICATIONS RECORDERS FOR ENGINEERING CHANGES TO THE EUT BY THE LAB

No modifications were made to the EUT by the lab during the test.

---END---