

#05 GSM1900_Right Cheek_Ch512

DUT: 190327

Communication System: PCS; Frequency: 1850.2 MHz; Duty Cycle: 1:8.3

Medium: HSL_1900_110922 Medium parameters used: $f = 1850.2$ MHz; $\sigma = 1.38$ mho/m; $\epsilon_r = 39.1$;

$\rho = 1000$ kg/m³

Ambient Temperature : 22.7 °C; Liquid Temperature : 21.7 °C

DASY4 Configuration:

- Probe: EX3DV4 - SN3754; ConvF(7.38, 7.38, 7.38); Calibrated: 2011/1/11
- Sensor-Surface: 4mm (Mechanical Surface Detection)
- Electronics: DAE4 Sn1279; Calibrated: 2011/6/17
- Phantom: SAM-Right; Type: QD 000 P40 C; Serial: TP-1383
- Measurement SW: DASY4, V4.7 Build 80; Postprocessing SW: SEMCAD, V1.8 Build 186

Ch512/Area Scan (51x91x1): Measurement grid: dx=15mm, dy=15mm

Maximum value of SAR (interpolated) = 0.555 mW/g

Ch512/Zoom Scan (5x5x7)/Cube 0: Measurement grid: dx=8mm, dy=8mm, dz=5mm

Reference Value = 10.1 V/m; Power Drift = 0.137 dB

Peak SAR (extrapolated) = 0.739 W/kg

SAR(1 g) = 0.497 mW/g; SAR(10 g) = 0.311 mW/g

Maximum value of SAR (measured) = 0.526 mW/g

Ch512/Zoom Scan (5x5x7)/Cube 1: Measurement grid: dx=8mm, dy=8mm, dz=5mm

Reference Value = 10.1 V/m; Power Drift = 0.137 dB

Peak SAR (extrapolated) = 0.564 W/kg

SAR(1 g) = 0.384 mW/g; SAR(10 g) = 0.254 mW/g

Maximum value of SAR (measured) = 0.437 mW/g

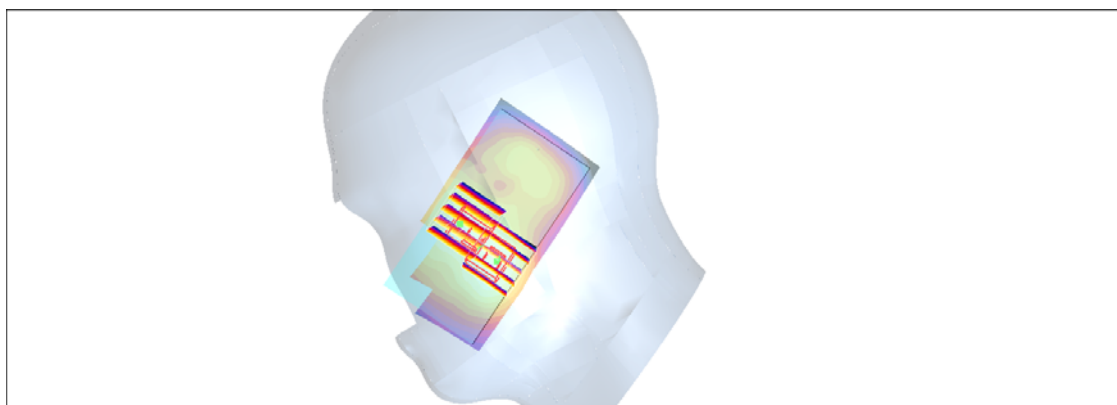
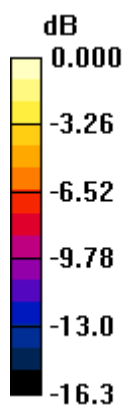

0 dB = 0.437mW/g

#06 GSM1900_Right Tilted_Ch512

DUT: 190327

Communication System: PCS; Frequency: 1850.2 MHz; Duty Cycle: 1:8.3

Medium: HSL_1900_110922 Medium parameters used: $f = 1850.2$ MHz; $\sigma = 1.38$ mho/m; $\epsilon_r = 39.1$;

$\rho = 1000$ kg/m³

Ambient Temperature : 22.7 °C ; Liquid Temperature : 21.7 °C

DASY4 Configuration:

- Probe: EX3DV4 - SN3754; ConvF(7.38, 7.38, 7.38); Calibrated: 2011/1/11

- Sensor-Surface: 4mm (Mechanical Surface Detection)

- Electronics: DAE4 Sn1279; Calibrated: 2011/6/17

- Phantom: SAM-Right; Type: QD 000 P40 C; Serial: TP-1383

- Measurement SW: DASY4, V4.7 Build 80; Postprocessing SW: SEMCAD, V1.8 Build 186

Ch512/Area Scan (51x91x1): Measurement grid: dx=15mm, dy=15mm

Maximum value of SAR (interpolated) = 0.571 mW/g

Ch512/Zoom Scan (5x5x7)/Cube 0: Measurement grid: dx=8mm, dy=8mm, dz=5mm

Reference Value = 18.0 V/m; Power Drift = -0.035 dB

Peak SAR (extrapolated) = 0.758 W/kg

SAR(1 g) = 0.468 mW/g; SAR(10 g) = 0.275 mW/g

Maximum value of SAR (measured) = 0.500 mW/g

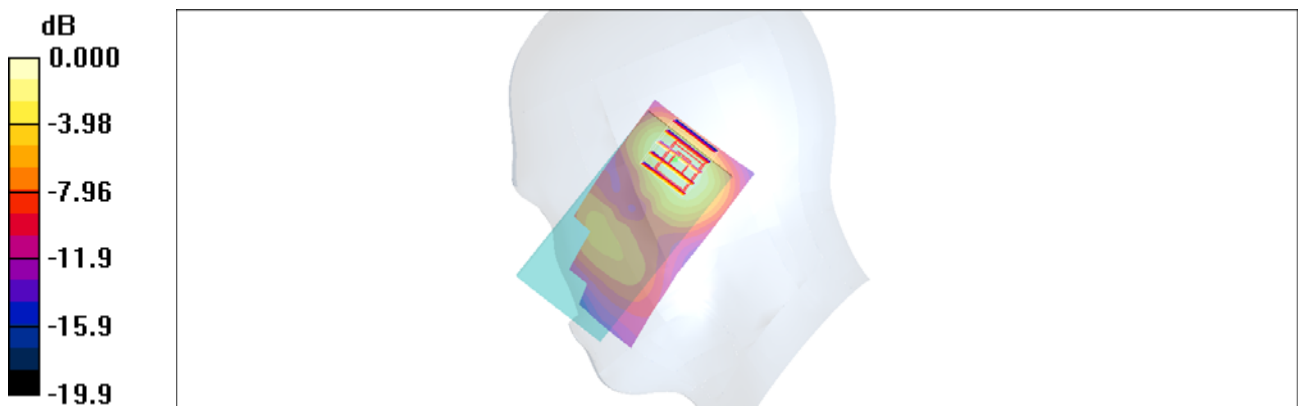

0 dB = 0.500mW/g

#07 GSM1900_Left Cheek_Ch512

DUT: 190327

Communication System: PCS; Frequency: 1850.2 MHz; Duty Cycle: 1:8.3

Medium: HSL_1900_110922 Medium parameters used: $f = 1850.2$ MHz; $\sigma = 1.38$ mho/m; $\epsilon_r = 39.1$;

$\rho = 1000$ kg/m³

Ambient Temperature : 22.7 °C ; Liquid Temperature : 21.7 °C

DASY4 Configuration:

- Probe: EX3DV4 - SN3754; ConvF(7.38, 7.38, 7.38); Calibrated: 2011/1/11
- Sensor-Surface: 4mm (Mechanical Surface Detection)
- Electronics: DAE4 Sn1279; Calibrated: 2011/6/17
- Phantom: SAM-Right; Type: QD 000 P40 C; Serial: TP-1383
- Measurement SW: DASY4, V4.7 Build 80; Postprocessing SW: SEMCAD, V1.8 Build 186

Ch512/Area Scan (51x91x1): Measurement grid: dx=15mm, dy=15mm

Maximum value of SAR (interpolated) = 0.592 mW/g

Ch512/Zoom Scan (5x5x7)/Cube 0: Measurement grid: dx=8mm, dy=8mm, dz=5mm

Reference Value = 8.25 V/m; Power Drift = 0.123 dB

Peak SAR (extrapolated) = 0.850 W/kg

SAR(1 g) = 0.538 mW/g; SAR(10 g) = 0.329 mW/g

Maximum value of SAR (measured) = 0.579 mW/g

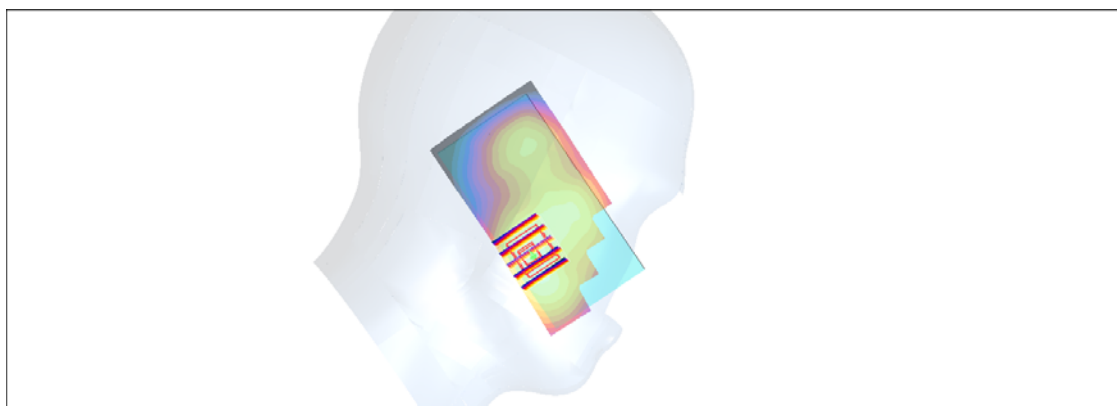
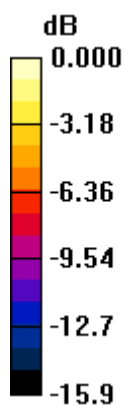

0 dB = 0.579mW/g

#08 GSM1900_Left Tilted_Ch512

DUT: 190327

Communication System: PCS; Frequency: 1850.2 MHz; Duty Cycle: 1:8.3

Medium: HSL_1900_110922 Medium parameters used: $f = 1850.2$ MHz; $\sigma = 1.38$ mho/m; $\epsilon_r = 39.1$;

$\rho = 1000$ kg/m³

Ambient Temperature : 22.7 °C; Liquid Temperature : 21.7 °C

DASY4 Configuration:

- Probe: EX3DV4 - SN3754; ConvF(7.38, 7.38, 7.38); Calibrated: 2011/1/11
- Sensor-Surface: 4mm (Mechanical Surface Detection)
- Electronics: DAE4 Sn1279; Calibrated: 2011/6/17
- Phantom: SAM-Right; Type: QD 000 P40 C; Serial: TP-1383
- Measurement SW: DASY4, V4.7 Build 80; Postprocessing SW: SEMCAD, V1.8 Build 186

Ch512/Area Scan (51x91x1): Measurement grid: dx=15mm, dy=15mm

Maximum value of SAR (interpolated) = 0.690 mW/g

Ch512/Zoom Scan (5x5x7)/Cube 0: Measurement grid: dx=8mm, dy=8mm, dz=5mm

Reference Value = 16.1 V/m; Power Drift = -0.066 dB

Peak SAR (extrapolated) = 0.926 W/kg

SAR(1 g) = 0.553 mW/g; SAR(10 g) = 0.320 mW/g

Maximum value of SAR (measured) = 0.594 mW/g

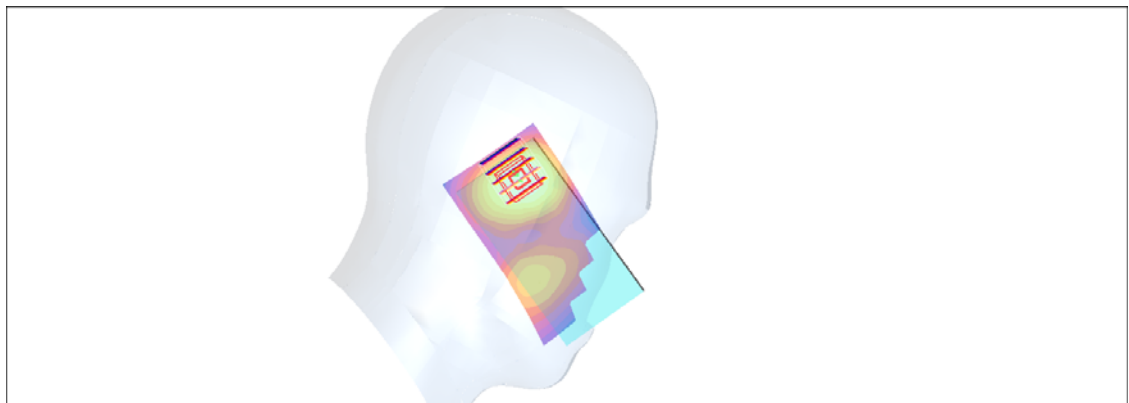
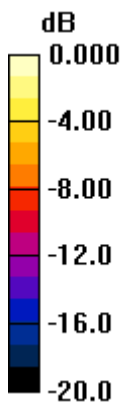

0 dB = 0.594mW/g

#08 GSM1900_Left Tilted_Ch512_2D

DUT: 190327

Communication System: PCS; Frequency: 1850.2 MHz; Duty Cycle: 1:8.3

Medium: HSL_1900_110922 Medium parameters used: $f = 1850.2$ MHz; $\sigma = 1.38$ mho/m; $\epsilon_r = 39.1$;

$\rho = 1000$ kg/m³

Ambient Temperature : 22.7 °C ; Liquid Temperature : 21.7 °C

DASY4 Configuration:

- Probe: EX3DV4 - SN3754; ConvF(7.38, 7.38, 7.38); Calibrated: 2011/1/11
- Sensor-Surface: 4mm (Mechanical Surface Detection)
- Electronics: DAE4 Sn1279; Calibrated: 2011/6/17
- Phantom: SAM-Right; Type: QD 000 P40 C; Serial: TP-1383
- Measurement SW: DASY4, V4.7 Build 80; Postprocessing SW: SEMCAD, V1.8 Build 186

Ch512/Area Scan (51x91x1): Measurement grid: dx=15mm, dy=15mm

Maximum value of SAR (interpolated) = 0.690 mW/g

Ch512/Zoom Scan (5x5x7)/Cube 0: Measurement grid: dx=8mm, dy=8mm, dz=5mm

Reference Value = 16.1 V/m; Power Drift = -0.066 dB

Peak SAR (extrapolated) = 0.926 W/kg

SAR(1 g) = 0.553 mW/g; SAR(10 g) = 0.320 mW/g

Maximum value of SAR (measured) = 0.594 mW/g

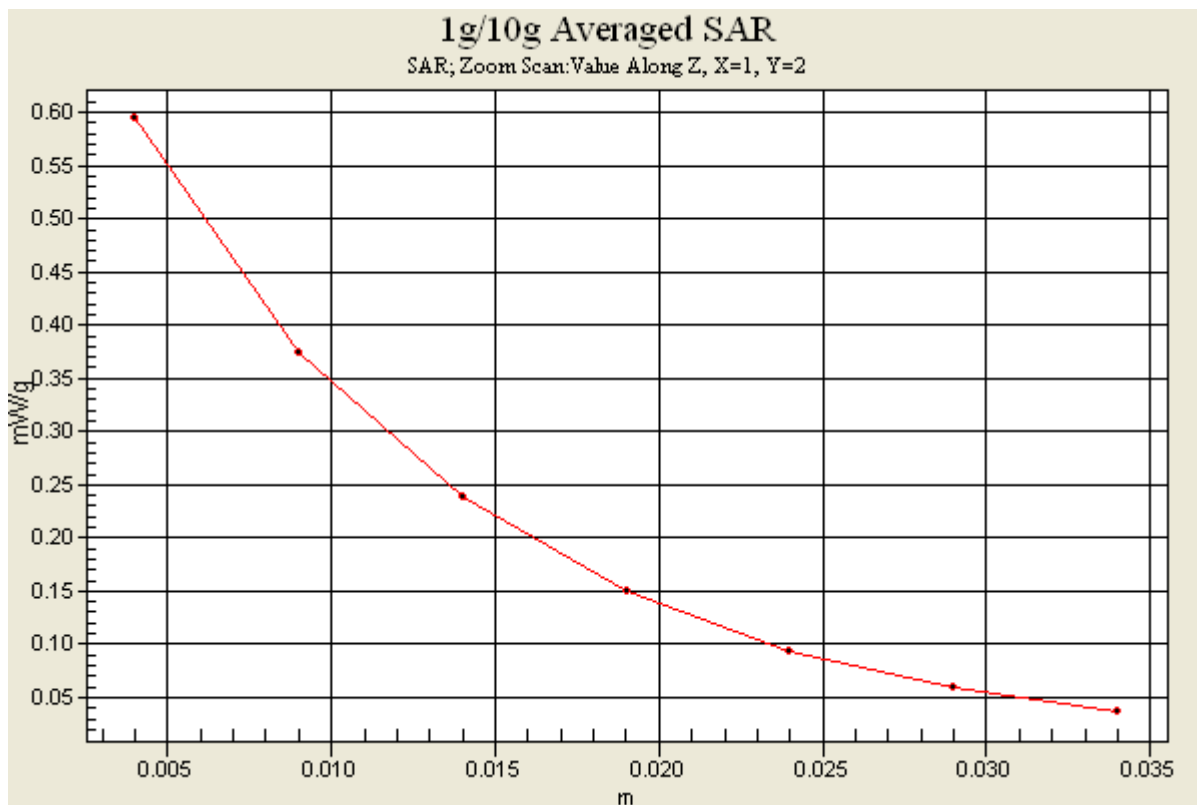

#01 CDMA2000 BC0_RC3+SO55_Right Cheek_Ch1013

DUT: 190327

Communication System: CDMA ; Frequency: 824.7 MHz; Duty Cycle: 1:1

Medium: HSL_850_110922 Medium parameters used: $f = 825$ MHz; $\sigma = 0.877$ mho/m; $\epsilon_r = 41.3$; $\rho = 1000$ kg/m³

Ambient Temperature : 22.4 °C ; Liquid Temperature : 21.4 °C

DASY4 Configuration:

- Probe: EX3DV4 - SN3754; ConvF(8.71, 8.71, 8.71); Calibrated: 2011/1/11
- Sensor-Surface: 4mm (Mechanical Surface Detection)
- Electronics: DAE4 Sn1279; Calibrated: 2011/6/17
- Phantom: SAM-Left; Type: QD 000 P40 C; Serial: TP-1478
- Measurement SW: DASY4, V4.7 Build 80; Postprocessing SW: SEMCAD, V1.8 Build 186

Ch1013/Area Scan (61x101x1): Measurement grid: dx=15mm, dy=15mm

Maximum value of SAR (interpolated) = 0.640 mW/g

Ch1013/Zoom Scan (5x5x7)/Cube 0: Measurement grid: dx=8mm, dy=8mm, dz=5mm

Reference Value = 10.5 V/m; Power Drift = 0.123 dB

Peak SAR (extrapolated) = 0.773 W/kg

SAR(1 g) = 0.626 mW/g; SAR(10 g) = 0.475 mW/g

Maximum value of SAR (measured) = 0.651 mW/g

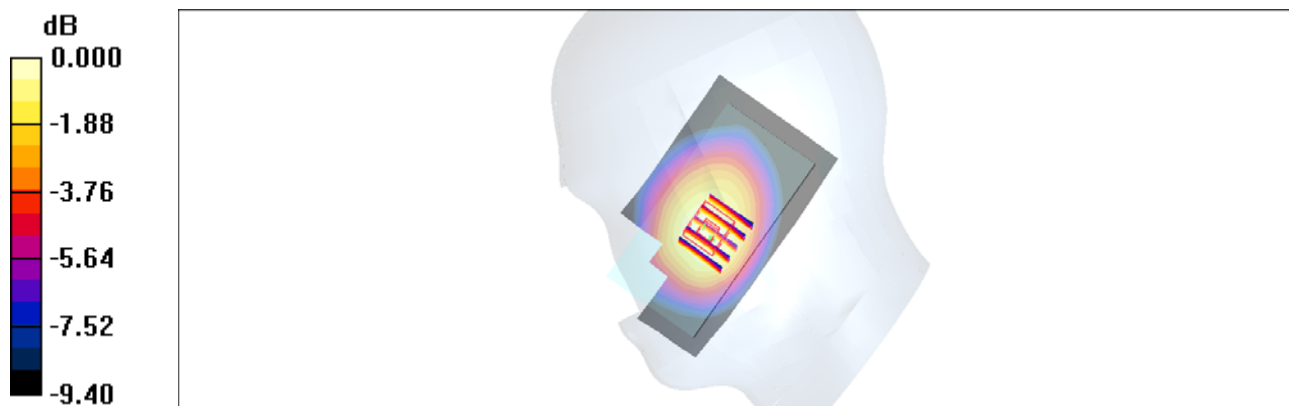

0 dB = 0.651mW/g

#02 CDMA2000 BC0_RC3+SO55_Right Tilted_Ch1013

DUT: 190327

Communication System: CDMA ; Frequency: 824.7 MHz; Duty Cycle: 1:1

Medium: HSL_850_110922 Medium parameters used: $f = 825$ MHz; $\sigma = 0.877$ mho/m; $\epsilon_r = 41.3$; $\rho = 1000$ kg/m³

Ambient Temperature : 22.4 °C ; Liquid Temperature : 21.4 °C

DASY4 Configuration:

- Probe: EX3DV4 - SN3754; ConvF(8.71, 8.71, 8.71); Calibrated: 2011/1/11
- Sensor-Surface: 4mm (Mechanical Surface Detection)
- Electronics: DAE4 Sn1279; Calibrated: 2011/6/17
- Phantom: SAM-Left; Type: QD 000 P40 C; Serial: TP-1478
- Measurement SW: DASY4, V4.7 Build 80; Postprocessing SW: SEMCAD, V1.8 Build 186

Ch1013/Area Scan (61x101x1): Measurement grid: dx=15mm, dy=15mm

Maximum value of SAR (interpolated) = 0.506 mW/g

Ch1013/Zoom Scan (5x5x7)/Cube 0: Measurement grid: dx=8mm, dy=8mm, dz=5mm

Reference Value = 17.1 V/m; Power Drift = 0.144 dB

Peak SAR (extrapolated) = 0.627 W/kg

SAR(1 g) = 0.489 mW/g; SAR(10 g) = 0.371 mW/g

Maximum value of SAR (measured) = 0.512 mW/g

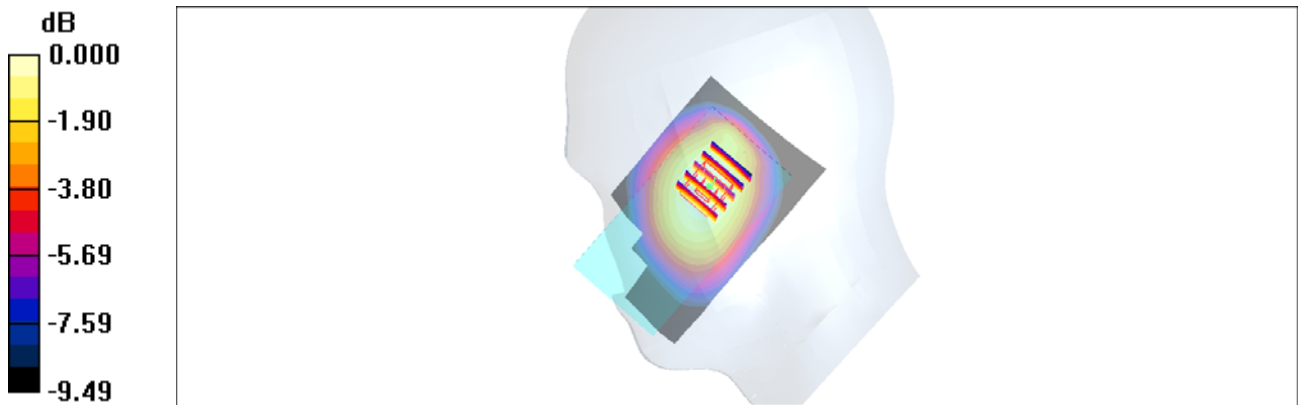

0 dB = 0.512mW/g

#03 CDMA2000 BC0_RC3+SO55_Left Cheek_Ch1013

DUT: 190327

Communication System: CDMA ; Frequency: 824.7 MHz; Duty Cycle: 1:1

Medium: HSL_850_110922 Medium parameters used: $f = 825$ MHz; $\sigma = 0.877$ mho/m; $\epsilon_r = 41.3$; $\rho = 1000$ kg/m³

Ambient Temperature : 22.4 °C ; Liquid Temperature : 21.4 °C

DASY4 Configuration:

- Probe: EX3DV4 - SN3754; ConvF(8.71, 8.71, 8.71); Calibrated: 2011/1/11
- Sensor-Surface: 4mm (Mechanical Surface Detection)
- Electronics: DAE4 Sn1279; Calibrated: 2011/6/17
- Phantom: SAM-Left; Type: QD 000 P40 C; Serial: TP-1478
- Measurement SW: DASY4, V4.7 Build 80; Postprocessing SW: SEMCAD, V1.8 Build 186

Ch1013/Area Scan (61x101x1): Measurement grid: dx=15mm, dy=15mm

Maximum value of SAR (interpolated) = 0.695 mW/g

Ch1013/Zoom Scan (5x5x7)/Cube 0: Measurement grid: dx=8mm, dy=8mm, dz=5mm

Reference Value = 10.2 V/m; Power Drift = 0.180 dB

Peak SAR (extrapolated) = 0.837 W/kg

SAR(1 g) = 0.654 mW/g; SAR(10 g) = 0.493 mW/g

Maximum value of SAR (measured) = 0.686 mW/g

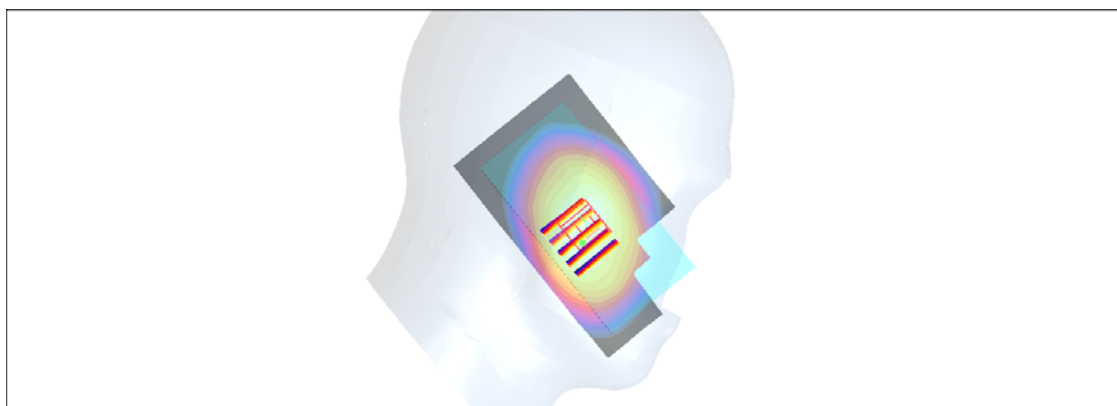
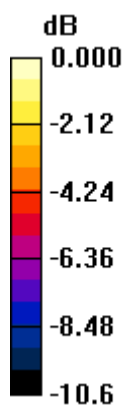

0 dB = 0.686mW/g

#03 CDMA2000 BC0_RC3+SO55_Left Cheek_Ch1013_2D

DUT: 190327

Communication System: CDMA ; Frequency: 824.7 MHz;Duty Cycle: 1:1

Medium: HSL_850_110922 Medium parameters used: $f = 825$ MHz; $\sigma = 0.877$ mho/m; $\epsilon_r = 41.3$; $\rho = 1000$ kg/m³

Ambient Temperature : 22.4 °C ; Liquid Temperature : 21.4 °C

DASY4 Configuration:

- Probe: EX3DV4 - SN3754; ConvF(8.71, 8.71, 8.71); Calibrated: 2011/1/11
- Sensor-Surface: 4mm (Mechanical Surface Detection)
- Electronics: DAE4 Sn1279; Calibrated: 2011/6/17
- Phantom: SAM-Left; Type: QD 000 P40 C; Serial: TP-1478
- Measurement SW: DASY4, V4.7 Build 80; Postprocessing SW: SEMCAD, V1.8 Build 186

Ch1013/Area Scan (61x101x1): Measurement grid: dx=15mm, dy=15mm

Maximum value of SAR (interpolated) = 0.695 mW/g

Ch1013/Zoom Scan (5x5x7)/Cube 0: Measurement grid: dx=8mm, dy=8mm, dz=5mm

Reference Value = 10.2 V/m; Power Drift = 0.180 dB

Peak SAR (extrapolated) = 0.837 W/kg

SAR(1 g) = 0.654 mW/g; SAR(10 g) = 0.493 mW/g

Maximum value of SAR (measured) = 0.686 mW/g

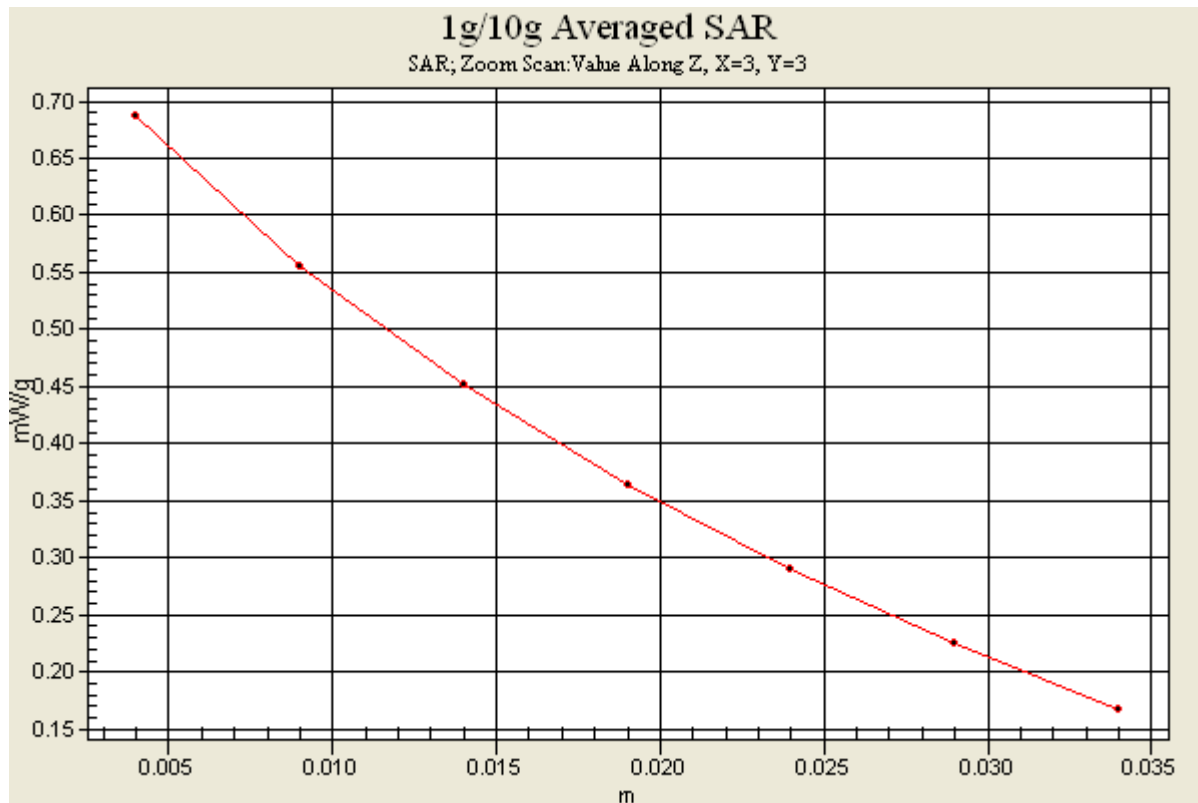

#04 CDMA2000 BC0_RC3+SO55_Left Tilted_Ch1013

DUT: 190327

Communication System: CDMA ; Frequency: 824.7 MHz; Duty Cycle: 1:1

Medium: HSL_850_110922 Medium parameters used: $f = 825$ MHz; $\sigma = 0.877$ mho/m; $\epsilon_r = 41.3$; $\rho = 1000$ kg/m³

Ambient Temperature : 22.4 °C ; Liquid Temperature : 21.4 °C

DASY4 Configuration:

- Probe: EX3DV4 - SN3754; ConvF(8.71, 8.71, 8.71); Calibrated: 2011/1/11
- Sensor-Surface: 4mm (Mechanical Surface Detection)
- Electronics: DAE4 Sn1279; Calibrated: 2011/6/17
- Phantom: SAM-Left; Type: QD 000 P40 C; Serial: TP-1478
- Measurement SW: DASY4, V4.7 Build 80; Postprocessing SW: SEMCAD, V1.8 Build 186

Ch1013/Area Scan (61x101x1): Measurement grid: dx=15mm, dy=15mm

Maximum value of SAR (interpolated) = 0.480 mW/g

Ch1013/Zoom Scan (5x5x7)/Cube 0: Measurement grid: dx=8mm, dy=8mm, dz=5mm

Reference Value = 17.1 V/m; Power Drift = 0.082 dB

Peak SAR (extrapolated) = 0.583 W/kg

SAR(1 g) = 0.458 mW/g; SAR(10 g) = 0.345 mW/g

Maximum value of SAR (measured) = 0.486 mW/g

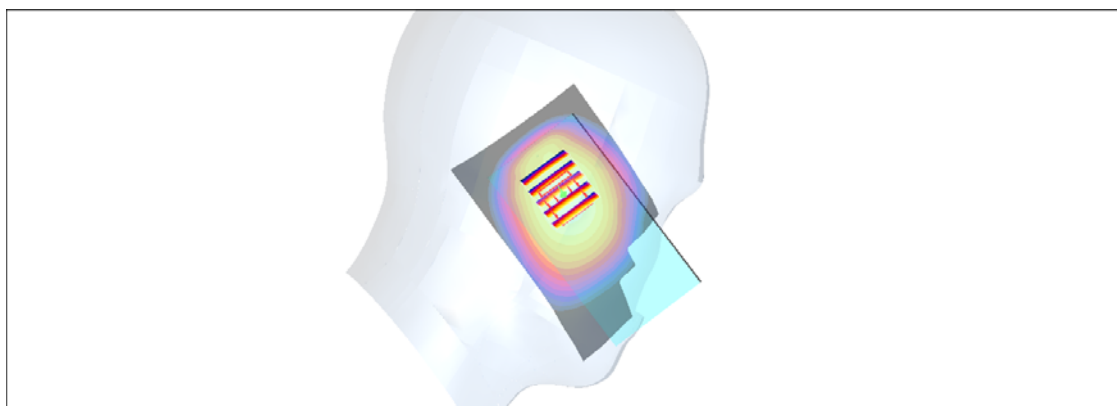
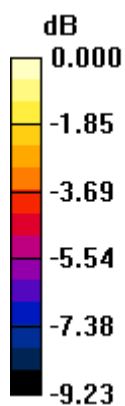

0 dB = 0.486mW/g

#15 GSM1900_GPRS10_Front_1cm_Ch512

DUT: 190327

Communication System: PCS; Frequency: 1850.2 MHz; Duty Cycle: 1:4

Medium: MSL_1900_110923 Medium parameters used: $f = 1850.2$ MHz; $\sigma = 1.49$ mho/m; $\epsilon_r = 52.7$;

$\rho = 1000$ kg/m³

Ambient Temperature : 22.4 °C ; Liquid Temperature : 21.4 °C

DASY4 Configuration:

- Probe: EX3DV4 - SN3792; ConvF(7.17, 7.17, 7.17); Calibrated: 2011/6/20
- Sensor-Surface: 4mm (Mechanical Surface Detection)
- Electronics: DAE4 Sn905; Calibrated: 2011/6/24
- Phantom: SAM-Right; Type: QD 000 P40 C; Serial: TP-1383
- Measurement SW: DASY4, V4.7 Build 80; Postprocessing SW: SEMCAD, V1.8 Build 186

Ch512/Area Scan (61x101x1): Measurement grid: dx=15mm, dy=15mm

Maximum value of SAR (interpolated) = 0.472 mW/g

Ch512/Zoom Scan (5x5x7)/Cube 0: Measurement grid: dx=8mm, dy=8mm, dz=5mm

Reference Value = 5.25 V/m; Power Drift = -0.129 dB

Peak SAR (extrapolated) = 0.675 W/kg

SAR(1 g) = 0.413 mW/g; SAR(10 g) = 0.260 mW/g

Maximum value of SAR (measured) = 0.438 mW/g

Ch512/Zoom Scan (5x5x7)/Cube 1: Measurement grid: dx=8mm, dy=8mm, dz=5mm

Reference Value = 5.25 V/m; Power Drift = -0.129 dB

Peak SAR (extrapolated) = 0.495 W/kg

SAR(1 g) = 0.324 mW/g; SAR(10 g) = 0.198 mW/g

Maximum value of SAR (measured) = 0.352 mW/g

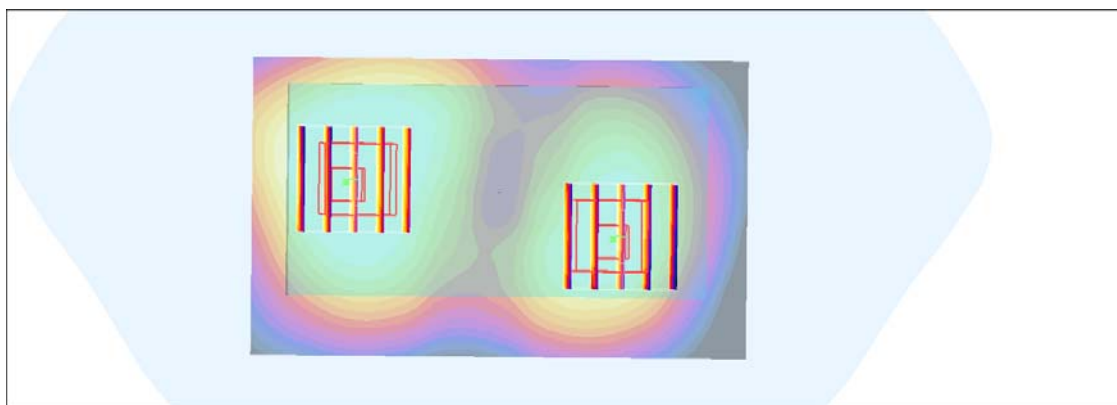
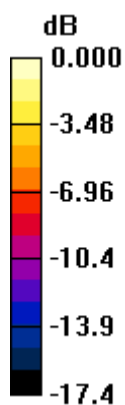

0 dB = 0.352mW/g

#16 GSM1900_GPRS10_Back_1cm_Ch512

DUT: 190327

Communication System: PCS; Frequency: 1850.2 MHz; Duty Cycle: 1:4

Medium: MSL_1900_110923 Medium parameters used: $f = 1850.2$ MHz; $\sigma = 1.49$ mho/m; $\epsilon_r = 52.7$;

$\rho = 1000$ kg/m³

Ambient Temperature : 22.4 °C ; Liquid Temperature : 21.4 °C

DASY4 Configuration:

- Probe: EX3DV4 - SN3792; ConvF(7.17, 7.17, 7.17); Calibrated: 2011/6/20

- Sensor-Surface: 4mm (Mechanical Surface Detection)

- Electronics: DAE4 Sn905; Calibrated: 2011/6/24

- Phantom: SAM-Right; Type: QD 000 P40 C; Serial: TP-1383

- Measurement SW: DASY4, V4.7 Build 80; Postprocessing SW: SEMCAD, V1.8 Build 186

Ch512/Area Scan (61x101x1): Measurement grid: dx=15mm, dy=15mm

Maximum value of SAR (interpolated) = 0.546 mW/g

Ch512/Zoom Scan (5x5x7)/Cube 0: Measurement grid: dx=8mm, dy=8mm, dz=5mm

Reference Value = 5.85 V/m; Power Drift = 0.049 dB

Peak SAR (extrapolated) = 0.741 W/kg

SAR(1 g) = 0.466 mW/g; SAR(10 g) = 0.291 mW/g

Maximum value of SAR (measured) = 0.500 mW/g

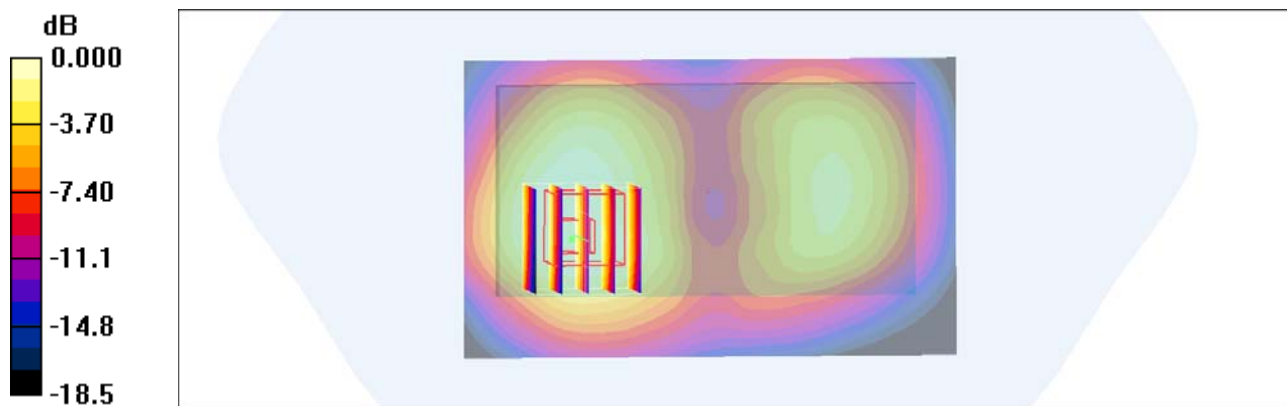

0 dB = 0.500mW/g

#16 GSM1900_GPRS10_Back_1cm_Ch512_2D

DUT: 190327

Communication System: PCS; Frequency: 1850.2 MHz; Duty Cycle: 1:4

Medium: MSL_1900_110923 Medium parameters used: $f = 1850.2$ MHz; $\sigma = 1.49$ mho/m; $\epsilon_r =$

52.7 ; $\rho = 1000$ kg/m³

Ambient Temperature : 22.4 °C ; Liquid Temperature : 21.4 °C

DASY4 Configuration:

- Probe: EX3DV4 - SN3792; ConvF(7.17, 7.17, 7.17); Calibrated: 2011/6/20
- Sensor-Surface: 4mm (Mechanical Surface Detection)
- Electronics: DAE4 Sn905; Calibrated: 2011/6/24
- Phantom: SAM-Right; Type: QD 000 P40 C; Serial: TP-1383
- Measurement SW: DASY4, V4.7 Build 80; Postprocessing SW: SEMCAD, V1.8 Build 186

Ch512/Area Scan (61x101x1): Measurement grid: dx=15mm, dy=15mm

Maximum value of SAR (interpolated) = 0.546 mW/g

Ch512/Zoom Scan (5x5x7)/Cube 0: Measurement grid: dx=8mm, dy=8mm, dz=5mm

Reference Value = 5.85 V/m; Power Drift = 0.049 dB

Peak SAR (extrapolated) = 0.741 W/kg

SAR(1 g) = 0.466 mW/g; SAR(10 g) = 0.291 mW/g

Maximum value of SAR (measured) = 0.500 mW/g

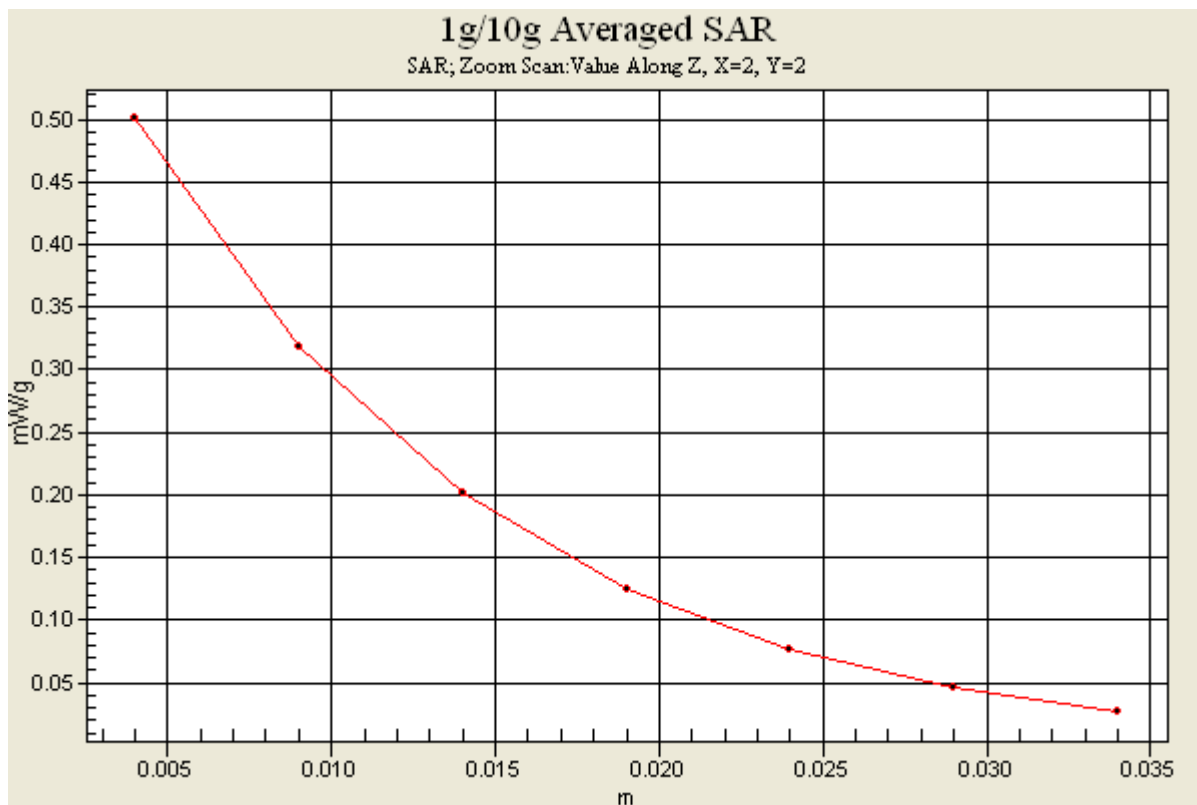

#17 GSM1900_GPRS10_Left Side_1cm_Ch512

DUT: 190327

Communication System: PCS; Frequency: 1850.2 MHz; Duty Cycle: 1:4

Medium: MSL_1900_110923 Medium parameters used: $f = 1850.2$ MHz; $\sigma = 1.49$ mho/m; $\epsilon_r = 52.7$;

$\rho = 1000$ kg/m³

Ambient Temperature : 22.4 °C ; Liquid Temperature : 21.4 °C

DASY4 Configuration:

- Probe: EX3DV4 - SN3792; ConvF(7.17, 7.17, 7.17); Calibrated: 2011/6/20
- Sensor-Surface: 4mm (Mechanical Surface Detection)
- Electronics: DAE4 Sn905; Calibrated: 2011/6/24
- Phantom: SAM-Right; Type: QD 000 P40 C; Serial: TP-1383
- Measurement SW: DASY4, V4.7 Build 80; Postprocessing SW: SEMCAD, V1.8 Build 186

Ch512/Area Scan (41x101x1): Measurement grid: dx=15mm, dy=15mm

Maximum value of SAR (interpolated) = 0.242 mW/g

Ch512/Zoom Scan (5x5x7)/Cube 0: Measurement grid: dx=8mm, dy=8mm, dz=5mm

Reference Value = 9.84 V/m; Power Drift = -0.186 dB

Peak SAR (extrapolated) = 0.340 W/kg

SAR(1 g) = 0.206 mW/g; SAR(10 g) = 0.120 mW/g

Maximum value of SAR (measured) = 0.223 mW/g

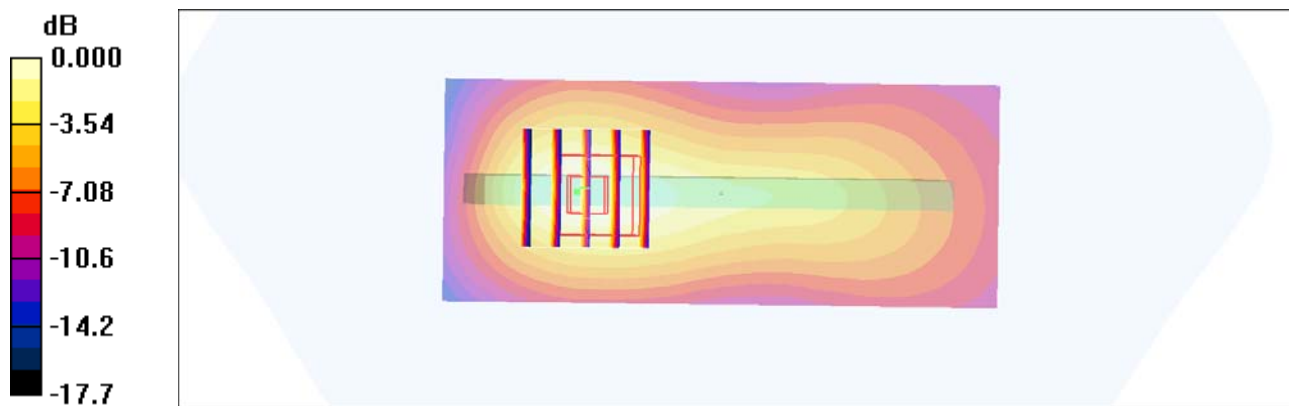

0 dB = 0.223mW/g

#18 GSM1900_GPRS10_Right Side_1cm_Ch512

DUT: 190327

Communication System: PCS; Frequency: 1850.2 MHz; Duty Cycle: 1:4

Medium: MSL_1900_110923 Medium parameters used: $f = 1850.2$ MHz; $\sigma = 1.49$ mho/m; $\epsilon_r = 52.7$;

$\rho = 1000$ kg/m³

Ambient Temperature : 22.4 °C ; Liquid Temperature : 21.4 °C

DASY4 Configuration:

- Probe: EX3DV4 - SN3792; ConvF(7.17, 7.17, 7.17); Calibrated: 2011/6/20
- Sensor-Surface: 4mm (Mechanical Surface Detection)
- Electronics: DAE4 Sn905; Calibrated: 2011/6/24
- Phantom: SAM-Right; Type: QD 000 P40 C; Serial: TP-1383
- Measurement SW: DASY4, V4.7 Build 80; Postprocessing SW: SEMCAD, V1.8 Build 186

Ch512/Area Scan (41x101x1): Measurement grid: dx=15mm, dy=15mm

Maximum value of SAR (interpolated) = 0.148 mW/g

Ch512/Zoom Scan (5x5x7)/Cube 0: Measurement grid: dx=8mm, dy=8mm, dz=5mm

Reference Value = 4.70 V/m; Power Drift = -0.003 dB

Peak SAR (extrapolated) = 0.217 W/kg

SAR(1 g) = 0.133 mW/g; SAR(10 g) = 0.078 mW/g

Maximum value of SAR (measured) = 0.145 mW/g

Ch512/Zoom Scan (5x5x7)/Cube 1: Measurement grid: dx=8mm, dy=8mm, dz=5mm

Reference Value = 4.70 V/m; Power Drift = -0.003 dB

Peak SAR (extrapolated) = 0.206 W/kg

SAR(1 g) = 0.126 mW/g; SAR(10 g) = 0.074 mW/g

Maximum value of SAR (measured) = 0.137 mW/g

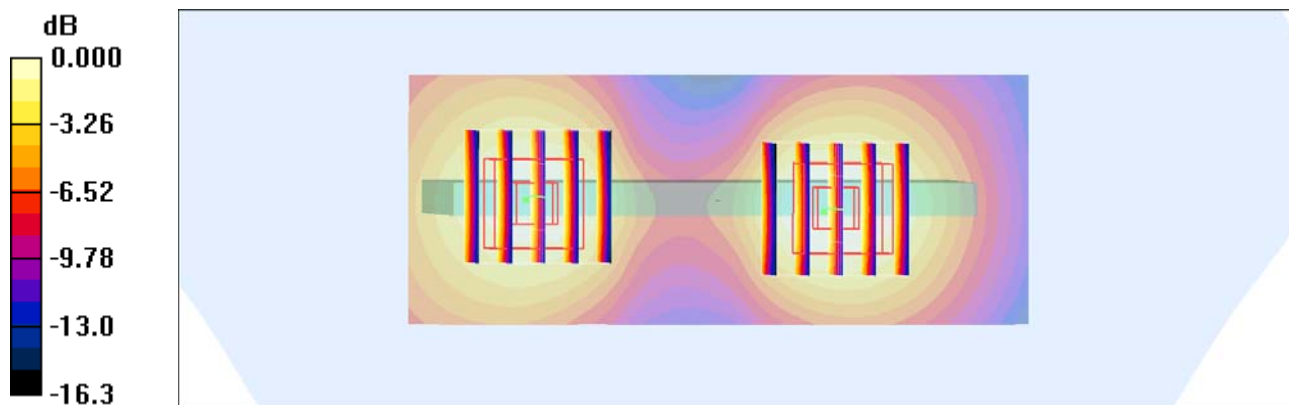

0 dB = 0.137mW/g

#19 GSM1900_GPRS10_Top Side_1cm_Ch512

DUT: 190327

Communication System: PCS; Frequency: 1850.2 MHz; Duty Cycle: 1:4

Medium: MSL_1900_110923 Medium parameters used: $f = 1850.2$ MHz; $\sigma = 1.49$ mho/m; $\epsilon_r = 52.7$;

$\rho = 1000$ kg/m³

Ambient Temperature : 22.4 °C ; Liquid Temperature : 21.4 °C

DASY4 Configuration:

- Probe: EX3DV4 - SN3792; ConvF(7.17, 7.17, 7.17); Calibrated: 2011/6/20

- Sensor-Surface: 4mm (Mechanical Surface Detection)

- Electronics: DAE4 Sn905; Calibrated: 2011/6/24

- Phantom: SAM-Right; Type: QD 000 P40 C; Serial: TP-1383

- Measurement SW: DASY4, V4.7 Build 80; Postprocessing SW: SEMCAD, V1.8 Build 186

Ch512/Area Scan (41x61x1): Measurement grid: dx=15mm, dy=15mm

Maximum value of SAR (interpolated) = 0.041 mW/g

Ch512/Zoom Scan (5x5x7)/Cube 0: Measurement grid: dx=8mm, dy=8mm, dz=5mm

Reference Value = 4.42 V/m; Power Drift = -0.083 dB

Peak SAR (extrapolated) = 0.060 W/kg

SAR(1 g) = 0.037 mW/g; SAR(10 g) = 0.023 mW/g

Maximum value of SAR (measured) = 0.040 mW/g

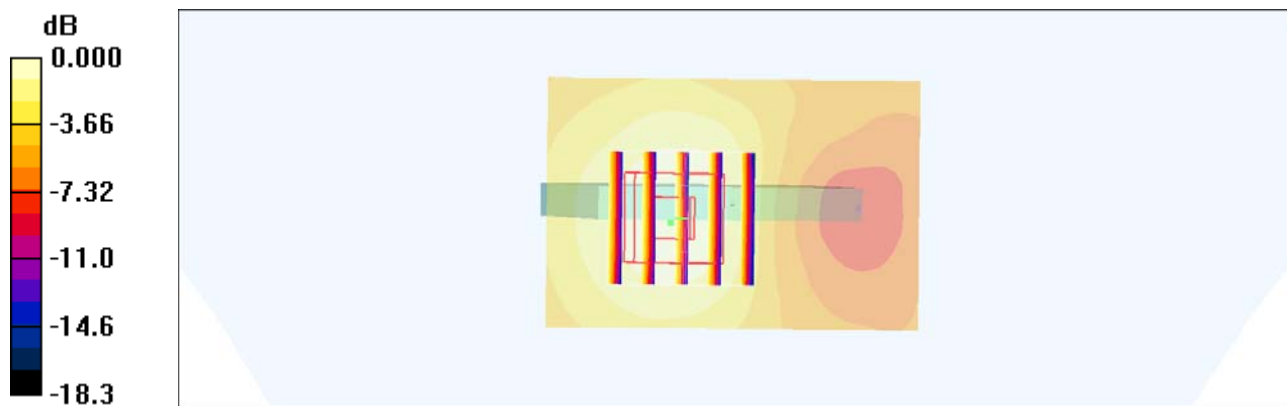

0 dB = 0.040mW/g

#20 GSM1900_GPRS10_Bottom Side_1cm_Ch512

DUT: 190327

Communication System: PCS; Frequency: 1850.2 MHz; Duty Cycle: 1:4

Medium: MSL_1900_110923 Medium parameters used: $f = 1850.2$ MHz; $\sigma = 1.49$ mho/m; $\epsilon_r = 52.7$;

$\rho = 1000$ kg/m³

Ambient Temperature : 22.4 °C ; Liquid Temperature : 21.4 °C

DASY4 Configuration:

- Probe: EX3DV4 - SN3792; ConvF(7.17, 7.17, 7.17); Calibrated: 2011/6/20

- Sensor-Surface: 4mm (Mechanical Surface Detection)

- Electronics: DAE4 Sn905; Calibrated: 2011/6/24

- Phantom: SAM-Right; Type: QD 000 P40 C; Serial: TP-1383

- Measurement SW: DASY4, V4.7 Build 80; Postprocessing SW: SEMCAD, V1.8 Build 186

Ch512/Area Scan (41x61x1): Measurement grid: dx=15mm, dy=15mm

Maximum value of SAR (interpolated) = 0.099 mW/g

Ch512/Zoom Scan (5x5x7)/Cube 0: Measurement grid: dx=8mm, dy=8mm, dz=5mm

Reference Value = 7.18 V/m; Power Drift = 0.089 dB

Peak SAR (extrapolated) = 0.134 W/kg

SAR(1 g) = 0.075 mW/g; SAR(10 g) = 0.043 mW/g

Maximum value of SAR (measured) = 0.080 mW/g

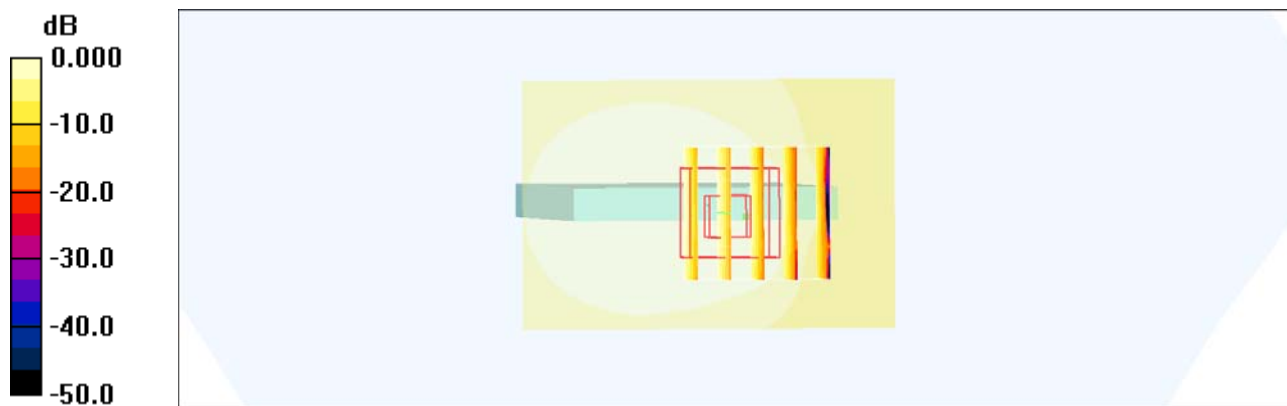

0 dB = 0.080mW/g

#15 GSM1900_GPRS10_Front_1cm_Ch512

DUT: 190327

Communication System: PCS; Frequency: 1850.2 MHz; Duty Cycle: 1:4

Medium: MSL_1900_110923 Medium parameters used: $f = 1850.2$ MHz; $\sigma = 1.49$ mho/m; $\epsilon_r = 52.7$;

$\rho = 1000$ kg/m³

Ambient Temperature : 22.4 °C ; Liquid Temperature : 21.4 °C

DASY4 Configuration:

- Probe: EX3DV4 - SN3792; ConvF(7.17, 7.17, 7.17); Calibrated: 2011/6/20
- Sensor-Surface: 4mm (Mechanical Surface Detection)
- Electronics: DAE4 Sn905; Calibrated: 2011/6/24
- Phantom: SAM-Right; Type: QD 000 P40 C; Serial: TP-1383
- Measurement SW: DASY4, V4.7 Build 80; Postprocessing SW: SEMCAD, V1.8 Build 186

Ch512/Area Scan (61x101x1): Measurement grid: dx=15mm, dy=15mm

Maximum value of SAR (interpolated) = 0.472 mW/g

Ch512/Zoom Scan (5x5x7)/Cube 0: Measurement grid: dx=8mm, dy=8mm, dz=5mm

Reference Value = 5.25 V/m; Power Drift = -0.129 dB

Peak SAR (extrapolated) = 0.675 W/kg

SAR(1 g) = 0.413 mW/g; SAR(10 g) = 0.260 mW/g

Maximum value of SAR (measured) = 0.438 mW/g

Ch512/Zoom Scan (5x5x7)/Cube 1: Measurement grid: dx=8mm, dy=8mm, dz=5mm

Reference Value = 5.25 V/m; Power Drift = -0.129 dB

Peak SAR (extrapolated) = 0.495 W/kg

SAR(1 g) = 0.324 mW/g; SAR(10 g) = 0.198 mW/g

Maximum value of SAR (measured) = 0.352 mW/g

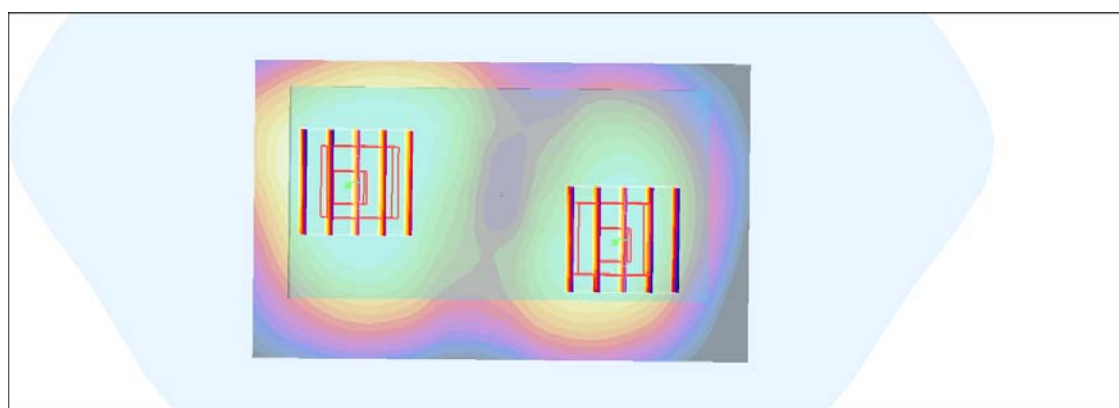
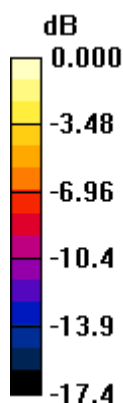

0 dB = 0.352mW/g

#16 GSM1900_GPRS10_Back_1cm_Ch512

DUT: 190327

Communication System: PCS; Frequency: 1850.2 MHz; Duty Cycle: 1:4

Medium: MSL_1900_110923 Medium parameters used: $f = 1850.2$ MHz; $\sigma = 1.49$ mho/m; $\epsilon_r = 52.7$;

$\rho = 1000$ kg/m³

Ambient Temperature : 22.4 °C ; Liquid Temperature : 21.4 °C

DASY4 Configuration:

- Probe: EX3DV4 - SN3792; ConvF(7.17, 7.17, 7.17); Calibrated: 2011/6/20

- Sensor-Surface: 4mm (Mechanical Surface Detection)

- Electronics: DAE4 Sn905; Calibrated: 2011/6/24

- Phantom: SAM-Right; Type: QD 000 P40 C; Serial: TP-1383

- Measurement SW: DASY4, V4.7 Build 80; Postprocessing SW: SEMCAD, V1.8 Build 186

Ch512/Area Scan (61x101x1): Measurement grid: dx=15mm, dy=15mm

Maximum value of SAR (interpolated) = 0.546 mW/g

Ch512/Zoom Scan (5x5x7)/Cube 0: Measurement grid: dx=8mm, dy=8mm, dz=5mm

Reference Value = 5.85 V/m; Power Drift = 0.049 dB

Peak SAR (extrapolated) = 0.741 W/kg

SAR(1 g) = 0.466 mW/g; SAR(10 g) = 0.291 mW/g

Maximum value of SAR (measured) = 0.500 mW/g

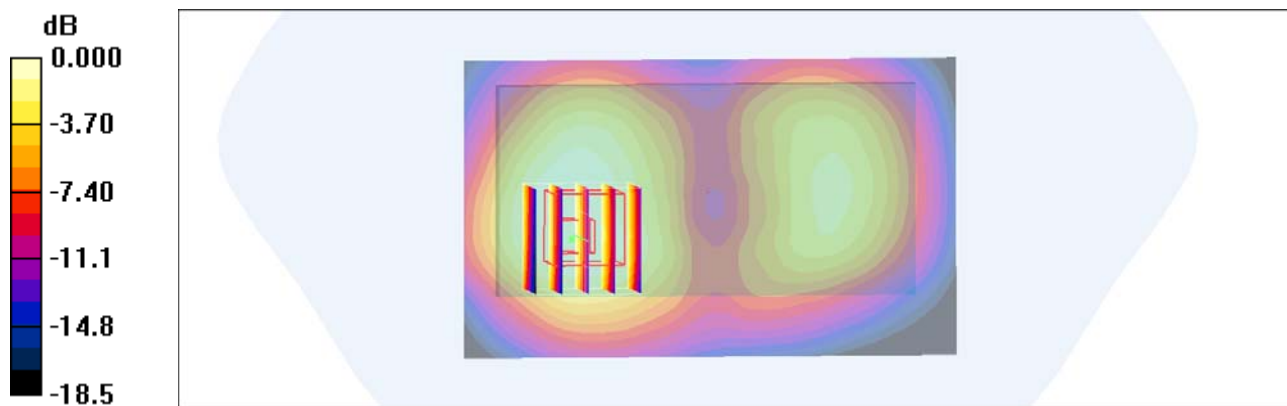

0 dB = 0.500mW/g

#21 GSM1900_GPRS10_Back_1cm_Ch512_Earphone

DUT: 190327

Communication System: PCS; Frequency: 1850.2 MHz; Duty Cycle: 1:4

Medium: MSL_1900_110923 Medium parameters used: $f = 1850.2$ MHz; $\sigma = 1.49$ mho/m; $\epsilon_r = 52.7$;

$\rho = 1000$ kg/m³

Ambient Temperature : 22.4 °C ; Liquid Temperature : 21.4 °C

DASY4 Configuration:

- Probe: EX3DV4 - SN3792; ConvF(7.17, 7.17, 7.17); Calibrated: 2011/6/20

- Sensor-Surface: 4mm (Mechanical Surface Detection)

- Electronics: DAE4 Sn905; Calibrated: 2011/6/24

- Phantom: SAM-Right; Type: QD 000 P40 C; Serial: TP-1383

- Measurement SW: DASY4, V4.7 Build 80; Postprocessing SW: SEMCAD, V1.8 Build 186

Ch512/Area Scan (61x101x1): Measurement grid: dx=15mm, dy=15mm

Maximum value of SAR (interpolated) = 0.540 mW/g

Ch512/Zoom Scan (5x5x7)/Cube 0: Measurement grid: dx=8mm, dy=8mm, dz=5mm

Reference Value = 7.67 V/m; Power Drift = -0.129 dB

Peak SAR (extrapolated) = 0.789 W/kg

SAR(1 g) = 0.460 mW/g; SAR(10 g) = 0.270 mW/g

Maximum value of SAR (measured) = 0.497 mW/g

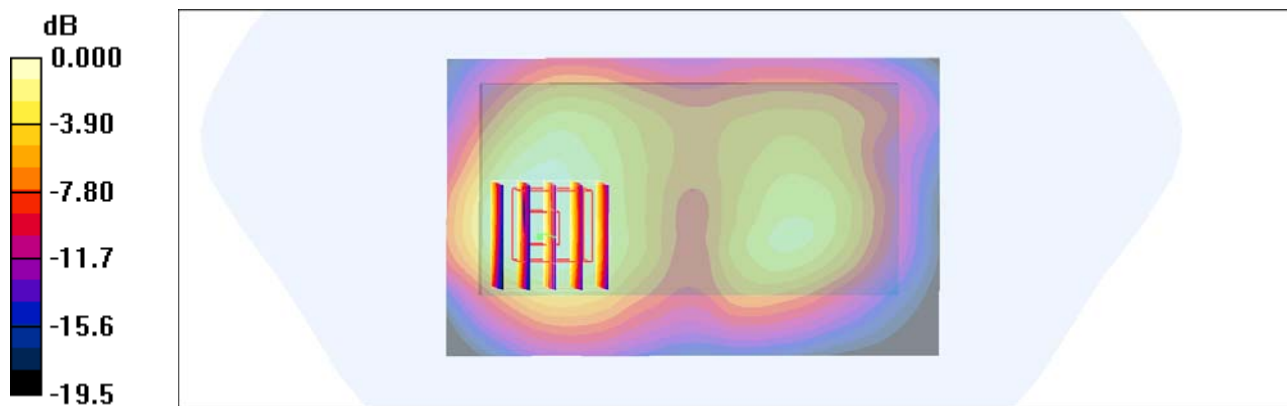

0 dB = 0.497mW/g

#09 CDMA2000 BC0_RC3+SO32_Front_1cm_Ch1013

DUT: 190327

Communication System: CDMA ; Frequency: 824.7 MHz; Duty Cycle: 1:1

Medium: MSL_850_110923 Medium parameters used: $f = 825$ MHz; $\sigma = 0.954$ mho/m; $\epsilon_r = 54.7$; $\rho = 1000$ kg/m³

Ambient Temperature : 22.3 °C ; Liquid Temperature : 21.3 °C

DASY4 Configuration:

- Probe: EX3DV4 - SN3792; ConvF(9.02, 9.02, 9.02); Calibrated: 2011/6/20
- Sensor-Surface: 4mm (Mechanical Surface Detection)
- Electronics: DAE4 Sn905; Calibrated: 2011/6/24
- Phantom: SAM-Left; Type: QD 000 P40 C; Serial: TP-1478
- Measurement SW: DASY4, V4.7 Build 80; Postprocessing SW: SEMCAD, V1.8 Build 186

Ch1013/Area Scan (61x101x1): Measurement grid: dx=15mm, dy=15mm

Maximum value of SAR (interpolated) = 0.977 mW/g

Ch1013/Zoom Scan (5x5x7)/Cube 0: Measurement grid: dx=8mm, dy=8mm, dz=5mm

Reference Value = 30.8 V/m; Power Drift = -0.175 dB

Peak SAR (extrapolated) = 1.14 W/kg

SAR(1 g) = 0.881 mW/g; SAR(10 g) = 0.670 mW/g

Maximum value of SAR (measured) = 0.953 mW/g

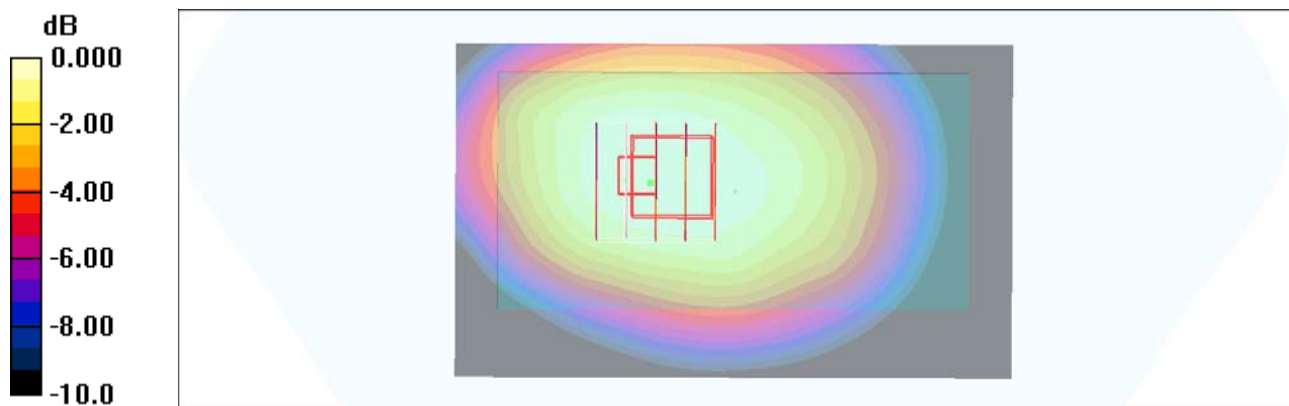

0 dB = 0.953mW/g

#10 CDMA2000 BC0_RC3+SO32_Back_1cm_Ch1013

DUT: 190327

Communication System: CDMA ; Frequency: 824.7 MHz;Duty Cycle: 1:1

Medium: MSL_850_110923 Medium parameters used: $f = 825 \text{ MHz}$; $\sigma = 0.954 \text{ mho/m}$; $\epsilon_r = 54.7$; $\rho = 1000 \text{ kg/m}^3$

Ambient Temperature : 22.3 °C ; Liquid Temperature : 21.3 °C

DASY4 Configuration:

- Probe: EX3DV4 - SN3792; ConvF(9.02, 9.02, 9.02); Calibrated: 2011/6/20
- Sensor-Surface: 4mm (Mechanical Surface Detection)
- Electronics: DAE4 Sn905; Calibrated: 2011/6/24
- Phantom: SAM-Left; Type: QD 000 P40 C; Serial: TP-1478
- Measurement SW: DASY4, V4.7 Build 80; Postprocessing SW: SEMCAD, V1.8 Build 186

Ch1013/Area Scan (61x101x1): Measurement grid: $dx=15\text{mm}$, $dy=15\text{mm}$

Maximum value of SAR (interpolated) = 1.08 mW/g

Ch1013/Zoom Scan (5x5x7)/Cube 0: Measurement grid: $dx=8\text{mm}$, $dy=8\text{mm}$, $dz=5\text{mm}$

Reference Value = 32.5 V/m; Power Drift = -0.068 dB

Peak SAR (extrapolated) = 1.31 W/kg

SAR(1 g) = 1.03 mW/g; SAR(10 g) = 0.773 mW/g

Maximum value of SAR (measured) = 1.08 mW/g

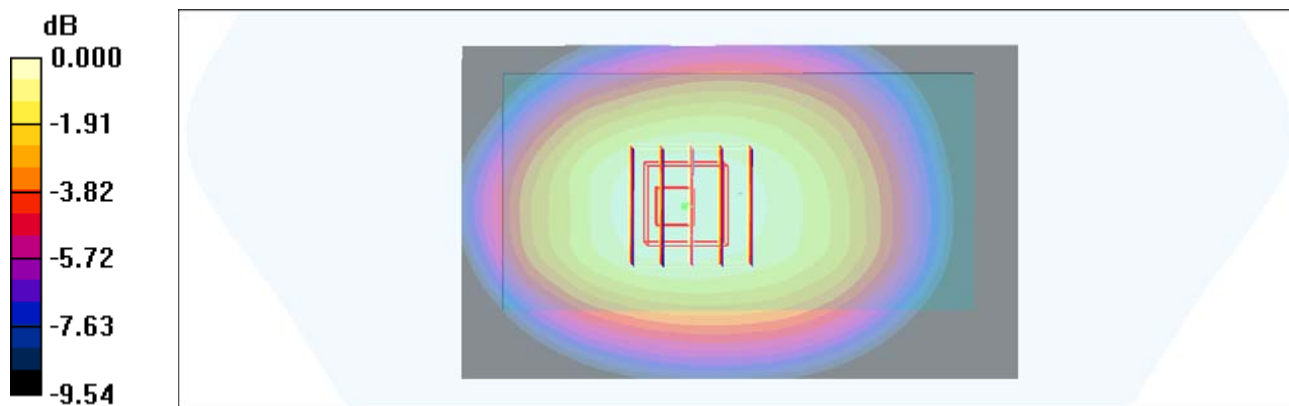

0 dB = 1.08mW/g

#11 CDMA2000 BC0_RC3+SO32_Left Side_1cm_Ch1013

DUT: 190327

Communication System: CDMA ; Frequency: 824.7 MHz; Duty Cycle: 1:1

Medium: MSL_850_110923 Medium parameters used: $f = 825$ MHz; $\sigma = 0.954$ mho/m; $\epsilon_r = 54.7$; $\rho = 1000$ kg/m³

Ambient Temperature : 22.3 °C ; Liquid Temperature : 21.3 °C

DASY4 Configuration:

- Probe: EX3DV4 - SN3792; ConvF(9.02, 9.02, 9.02); Calibrated: 2011/6/20
- Sensor-Surface: 4mm (Mechanical Surface Detection)
- Electronics: DAE4 Sn905; Calibrated: 2011/6/24
- Phantom: SAM-Left; Type: QD 000 P40 C; Serial: TP-1478
- Measurement SW: DASY4, V4.7 Build 80; Postprocessing SW: SEMCAD, V1.8 Build 186

Ch1013/Area Scan (31x101x1): Measurement grid: dx=15mm, dy=15mm

Maximum value of SAR (interpolated) = 0.493 mW/g

Ch1013/Zoom Scan (5x5x7)/Cube 0: Measurement grid: dx=8mm, dy=8mm, dz=5mm

Reference Value = 22.9 V/m; Power Drift = -0.188 dB

Peak SAR (extrapolated) = 0.649 W/kg

SAR(1 g) = 0.454 mW/g; SAR(10 g) = 0.312 mW/g

Maximum value of SAR (measured) = 0.483 mW/g

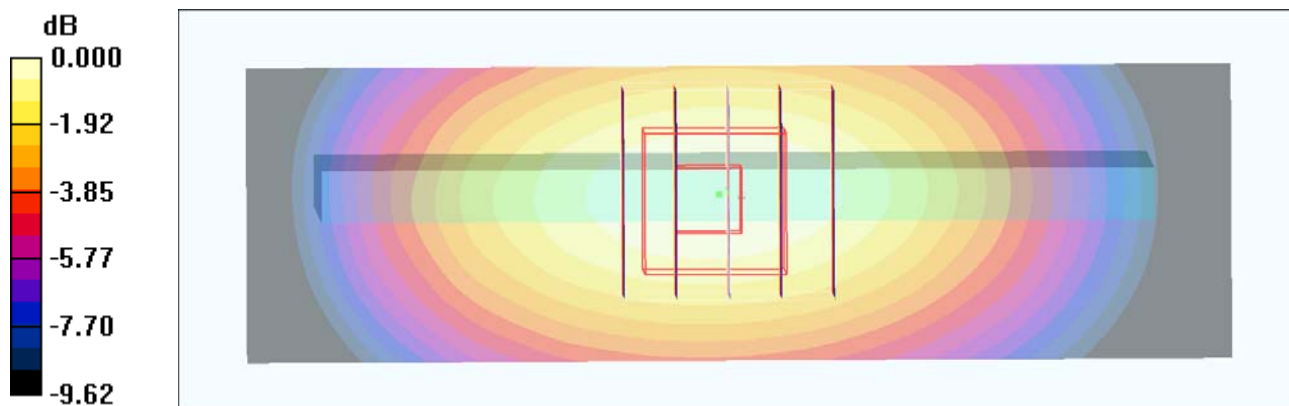

0 dB = 0.483mW/g

#12 CDMA2000 BC0_RC3+SO32_Right Side_1cm_Ch1013

DUT: 190327

Communication System: CDMA ; Frequency: 824.7 MHz; Duty Cycle: 1:1

Medium: MSL_850_110923 Medium parameters used: $f = 825$ MHz; $\sigma = 0.954$ mho/m; $\epsilon_r = 54.7$; $\rho = 1000$ kg/m³

Ambient Temperature : 22.3 °C ; Liquid Temperature : 21.3 °C

DASY4 Configuration:

- Probe: EX3DV4 - SN3792; ConvF(9.02, 9.02, 9.02); Calibrated: 2011/6/20
- Sensor-Surface: 4mm (Mechanical Surface Detection)
- Electronics: DAE4 Sn905; Calibrated: 2011/6/24
- Phantom: SAM-Left; Type: QD 000 P40 C; Serial: TP-1478
- Measurement SW: DASY4, V4.7 Build 80; Postprocessing SW: SEMCAD, V1.8 Build 186

Ch1013/Area Scan (31x101x1): Measurement grid: dx=15mm, dy=15mm

Maximum value of SAR (interpolated) = 0.571 mW/g

Ch1013/Zoom Scan (5x5x7)/Cube 0: Measurement grid: dx=8mm, dy=8mm, dz=5mm

Reference Value = 24.4 V/m; Power Drift = -0.014 dB

Peak SAR (extrapolated) = 0.762 W/kg

SAR(1 g) = 0.539 mW/g; SAR(10 g) = 0.374 mW/g

Maximum value of SAR (measured) = 0.573 mW/g

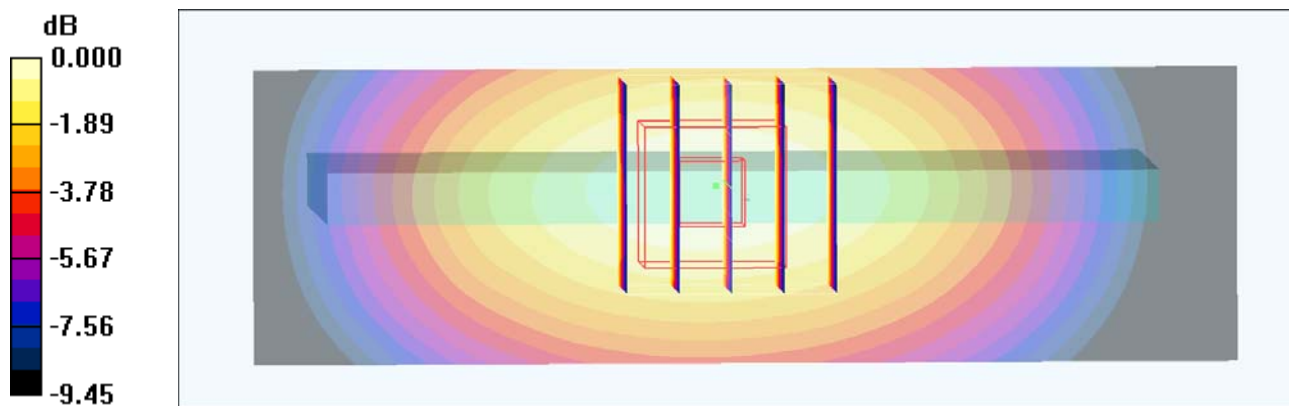

0 dB = 0.573mW/g

#13 CDMA2000 BC0_RC3+SO32_Top Side_1cm_Ch1013

DUT: 190327

Communication System: CDMA ; Frequency: 824.7 MHz; Duty Cycle: 1:1

Medium: MSL_850_110923 Medium parameters used: $f = 825 \text{ MHz}$; $\sigma = 0.954 \text{ mho/m}$; $\epsilon_r = 54.7$; $\rho = 1000 \text{ kg/m}^3$

Ambient Temperature : 22.3 °C ; Liquid Temperature : 21.3 °C

DASY4 Configuration:

- Probe: EX3DV4 - SN3792; ConvF(9.02, 9.02, 9.02); Calibrated: 2011/6/20
- Sensor-Surface: 4mm (Mechanical Surface Detection)
- Electronics: DAE4 Sn905; Calibrated: 2011/6/24
- Phantom: SAM-Left; Type: QD 000 P40 C; Serial: TP-1478
- Measurement SW: DASY4, V4.7 Build 80; Postprocessing SW: SEMCAD, V1.8 Build 186

Ch1013/Area Scan (51x61x1): Measurement grid: $dx=15\text{mm}$, $dy=15\text{mm}$

Maximum value of SAR (interpolated) = 0.025 mW/g

Ch1013/Zoom Scan (5x5x7)/Cube 0: Measurement grid: $dx=8\text{mm}$, $dy=8\text{mm}$, $dz=5\text{mm}$

Reference Value = 3.30 V/m; Power Drift = 0.173 dB

Peak SAR (extrapolated) = 0.030 W/kg

SAR(1 g) = 0.023 mW/g; SAR(10 g) = 0.017 mW/g

Maximum value of SAR (measured) = 0.024 mW/g

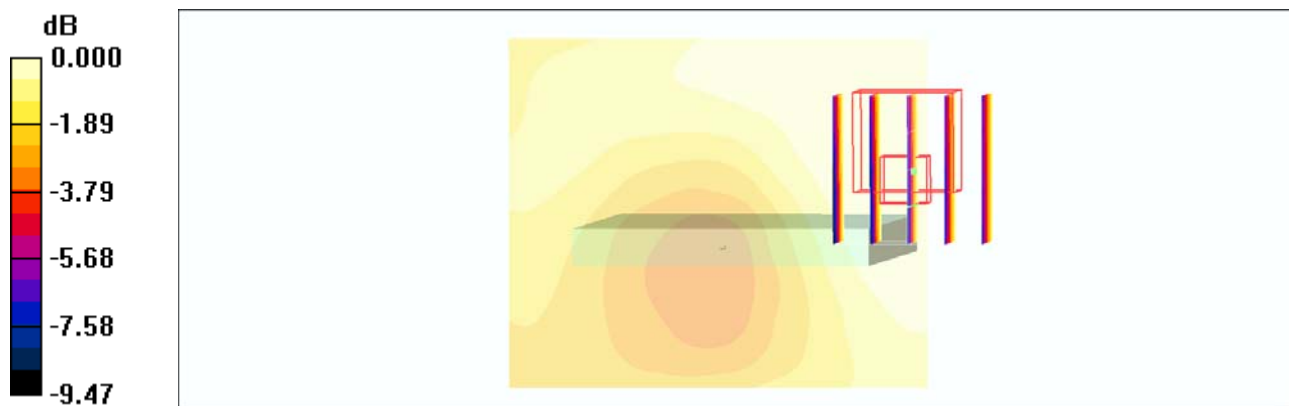

0 dB = 0.024mW/g

#14 CDMA2000 BC0_RC3+SO32_Bottom Side_1cm_Ch1013

DUT: 190327

Communication System: CDMA ; Frequency: 824.7 MHz; Duty Cycle: 1:1

Medium: MSL_850_110923 Medium parameters used: $f = 825$ MHz; $\sigma = 0.954$ mho/m; $\epsilon_r = 54.7$; $\rho = 1000$ kg/m³

Ambient Temperature : 22.3 °C ; Liquid Temperature : 21.3 °C

DASY4 Configuration:

- Probe: EX3DV4 - SN3792; ConvF(9.02, 9.02, 9.02); Calibrated: 2011/6/20
- Sensor-Surface: 4mm (Mechanical Surface Detection)
- Electronics: DAE4 Sn905; Calibrated: 2011/6/24
- Phantom: SAM-Left; Type: QD 000 P40 C; Serial: TP-1478
- Measurement SW: DASY4, V4.7 Build 80; Postprocessing SW: SEMCAD, V1.8 Build 186

Ch1013/Area Scan (51x61x1): Measurement grid: dx=15mm, dy=15mm

Maximum value of SAR (interpolated) = 0.105 mW/g

Ch1013/Zoom Scan (5x5x7)/Cube 0: Measurement grid: dx=8mm, dy=8mm, dz=5mm

Reference Value = 10.4 V/m; Power Drift = -0.189 dB

Peak SAR (extrapolated) = 0.161 W/kg

SAR(1 g) = 0.090 mW/g; SAR(10 g) = 0.050 mW/g

Maximum value of SAR (measured) = 0.102 mW/g

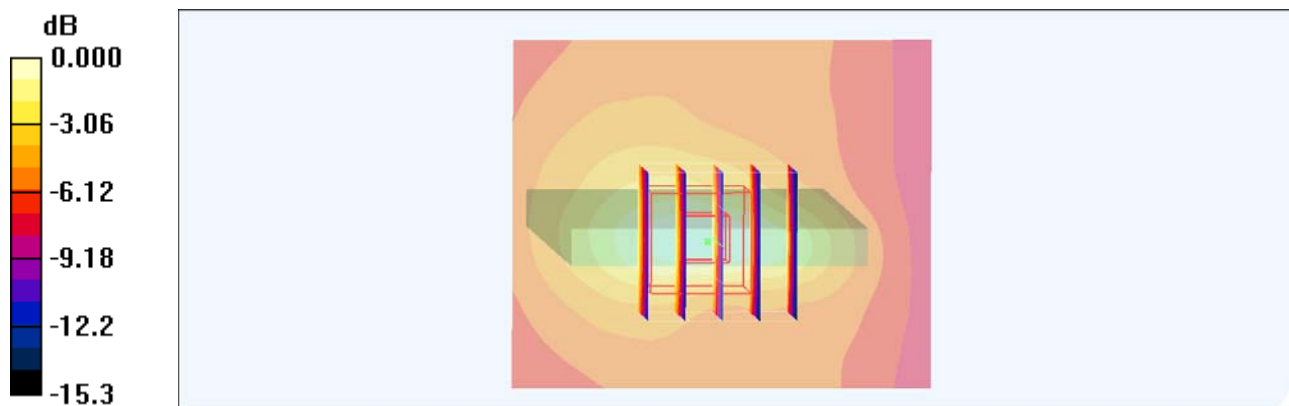

0 dB = 0.102mW/g

#09 CDMA2000 BC0_RC3+SO32_Front_1cm_Ch1013

DUT: 190327

Communication System: CDMA ; Frequency: 824.7 MHz; Duty Cycle: 1:1

Medium: MSL_850_110923 Medium parameters used: $f = 825$ MHz; $\sigma = 0.954$ mho/m; $\epsilon_r = 54.7$; $\rho = 1000$ kg/m³

Ambient Temperature : 22.3 °C ; Liquid Temperature : 21.3 °C

DASY4 Configuration:

- Probe: EX3DV4 - SN3792; ConvF(9.02, 9.02, 9.02); Calibrated: 2011/6/20
- Sensor-Surface: 4mm (Mechanical Surface Detection)
- Electronics: DAE4 Sn905; Calibrated: 2011/6/24
- Phantom: SAM-Left; Type: QD 000 P40 C; Serial: TP-1478
- Measurement SW: DASY4, V4.7 Build 80; Postprocessing SW: SEMCAD, V1.8 Build 186

Ch1013/Area Scan (61x101x1): Measurement grid: dx=15mm, dy=15mm

Maximum value of SAR (interpolated) = 0.977 mW/g

Ch1013/Zoom Scan (5x5x7)/Cube 0: Measurement grid: dx=8mm, dy=8mm, dz=5mm

Reference Value = 30.8 V/m; Power Drift = -0.175 dB

Peak SAR (extrapolated) = 1.14 W/kg

SAR(1 g) = 0.881 mW/g; SAR(10 g) = 0.670 mW/g

Maximum value of SAR (measured) = 0.953 mW/g

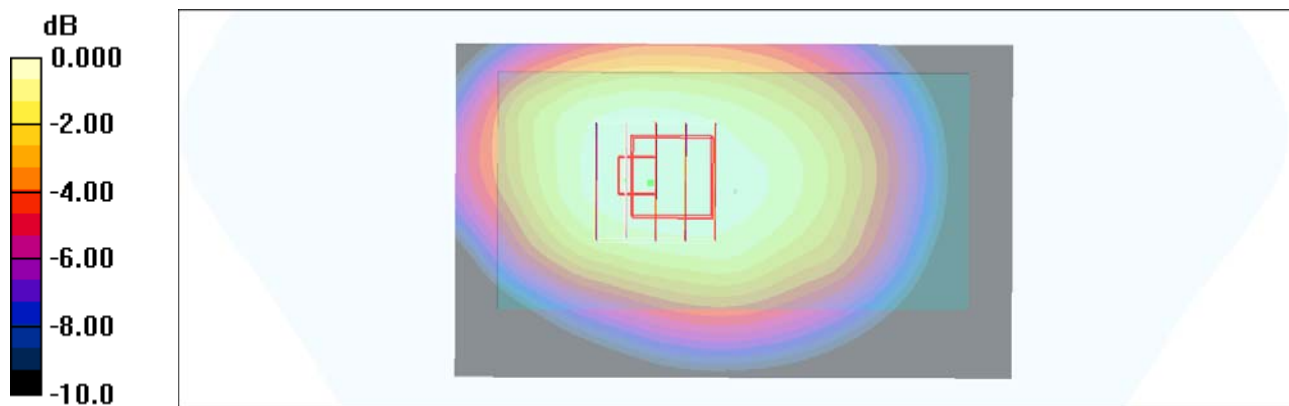

0 dB = 0.953mW/g

#22 CDMA2000 BC0_RC3+SO32_Front_1cm_Ch384

DUT: 190327

Communication System: CDMA ; Frequency: 836.52 MHz;Duty Cycle: 1:1

Medium: MSL_850_110923 Medium parameters used: $f = 837$ MHz; $\sigma = 0.965$ mho/m; $\epsilon_r = 54.5$; $\rho = 1000$ kg/m³

Ambient Temperature : 22.3 °C ; Liquid Temperature : 21.3 °C

DASY4 Configuration:

- Probe: EX3DV4 - SN3792; ConvF(9.02, 9.02, 9.02); Calibrated: 2011/6/20
- Sensor-Surface: 4mm (Mechanical Surface Detection)
- Electronics: DAE4 Sn905; Calibrated: 2011/6/24
- Phantom: SAM-Left; Type: QD 000 P40 C; Serial: TP-1478
- Measurement SW: DASY4, V4.7 Build 80; Postprocessing SW: SEMCAD, V1.8 Build 186

Ch384/Area Scan (61x101x1): Measurement grid: dx=15mm, dy=15mm

Maximum value of SAR (interpolated) = 1.04 mW/g

Ch384/Zoom Scan (5x5x7)/Cube 0: Measurement grid: dx=8mm, dy=8mm, dz=5mm

Reference Value = 31.3 V/m; Power Drift = 0.070 dB

Peak SAR (extrapolated) = 1.25 W/kg

SAR(1 g) = 0.992 mW/g; SAR(10 g) = 0.757 mW/g

Maximum value of SAR (measured) = 1.04 mW/g

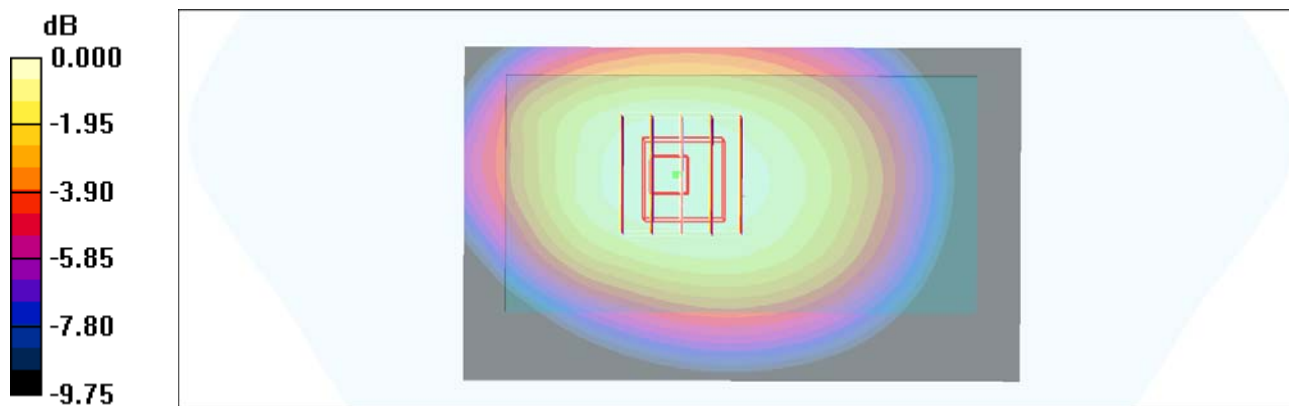

0 dB = 1.04mW/g

#23 CDMA2000 BC0_RC3+SO32_Front_1cm_Ch777

DUT: 190327

Communication System: CDMA ; Frequency: 848.31 MHz;Duty Cycle: 1:1

Medium: MSL_850_110923 Medium parameters used: $f = 848.31$ MHz; $\sigma = 0.976$ mho/m; $\epsilon_r = 54.4$;

$\rho = 1000$ kg/m³

Ambient Temperature : 22.3 °C ; Liquid Temperature : 21.3 °C

DASY4 Configuration:

- Probe: EX3DV4 - SN3792; ConvF(9.02, 9.02, 9.02); Calibrated: 2011/6/20
- Sensor-Surface: 4mm (Mechanical Surface Detection)
- Electronics: DAE4 Sn905; Calibrated: 2011/6/24
- Phantom: SAM-Left; Type: QD 000 P40 C; Serial: TP-1478
- Measurement SW: DASY4, V4.7 Build 80; Postprocessing SW: SEMCAD, V1.8 Build 186

Ch777/Area Scan (61x101x1): Measurement grid: dx=15mm, dy=15mm

Maximum value of SAR (interpolated) = 0.752 mW/g

Ch777/Zoom Scan (5x5x7)/Cube 0: Measurement grid: dx=8mm, dy=8mm, dz=5mm

Reference Value = 27.1 V/m; Power Drift = -0.090 dB

Peak SAR (extrapolated) = 0.893 W/kg

SAR(1 g) = 0.714 mW/g; SAR(10 g) = 0.545 mW/g

Maximum value of SAR (measured) = 0.745 mW/g

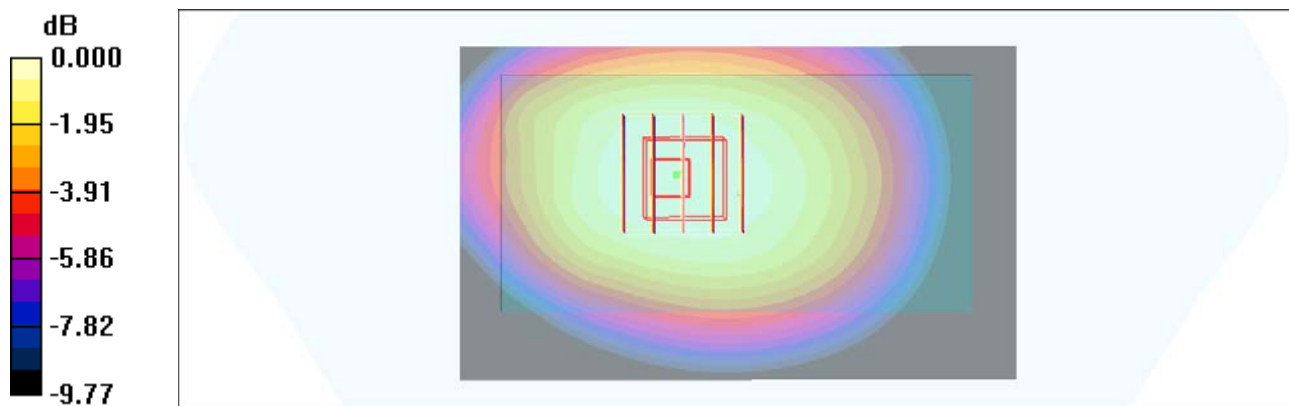

0 dB = 0.745mW/g

#10 CDMA2000 BC0_RC3+SO32_Back_1cm_Ch1013

DUT: 190327

Communication System: CDMA ; Frequency: 824.7 MHz; Duty Cycle: 1:1

Medium: MSL_850_110923 Medium parameters used: $f = 825 \text{ MHz}$; $\sigma = 0.954 \text{ mho/m}$; $\epsilon_r = 54.7$; $\rho = 1000 \text{ kg/m}^3$

Ambient Temperature : 22.3 °C ; Liquid Temperature : 21.3 °C

DASY4 Configuration:

- Probe: EX3DV4 - SN3792; ConvF(9.02, 9.02, 9.02); Calibrated: 2011/6/20
- Sensor-Surface: 4mm (Mechanical Surface Detection)
- Electronics: DAE4 Sn905; Calibrated: 2011/6/24
- Phantom: SAM-Left; Type: QD 000 P40 C; Serial: TP-1478
- Measurement SW: DASY4, V4.7 Build 80; Postprocessing SW: SEMCAD, V1.8 Build 186

Ch1013/Area Scan (61x101x1): Measurement grid: dx=15mm, dy=15mm

Maximum value of SAR (interpolated) = 1.08 mW/g

Ch1013/Zoom Scan (5x5x7)/Cube 0: Measurement grid: dx=8mm, dy=8mm, dz=5mm

Reference Value = 32.5 V/m; Power Drift = -0.068 dB

Peak SAR (extrapolated) = 1.31 W/kg

SAR(1 g) = 1.03 mW/g; SAR(10 g) = 0.773 mW/g

Maximum value of SAR (measured) = 1.08 mW/g

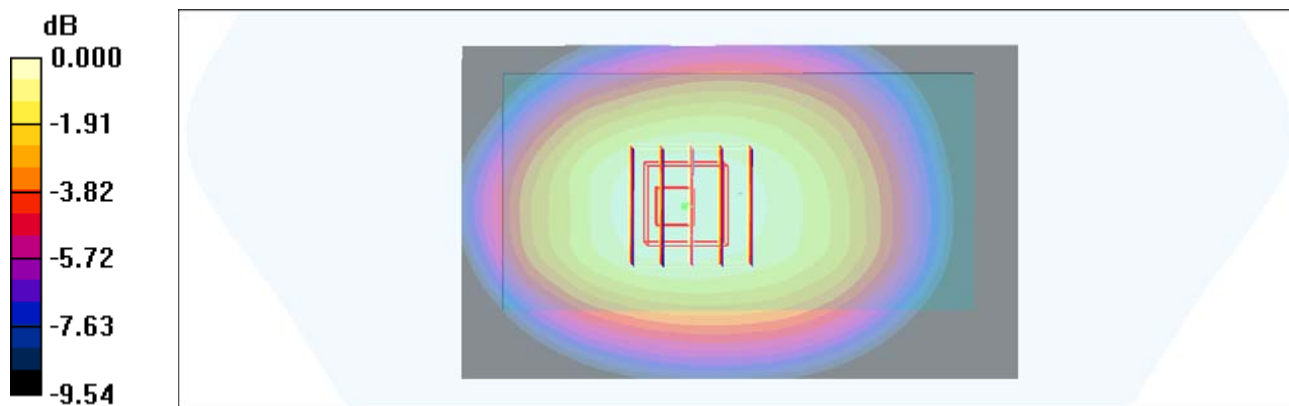

0 dB = 1.08mW/g

#24 CDMA2000 BC0_RC3+SO32_Back_1cm_Ch384

DUT: 190327

Communication System: CDMA ; Frequency: 836.52 MHz;Duty Cycle: 1:1

Medium: MSL_850_110923 Medium parameters used: $f = 837$ MHz; $\sigma = 0.965$ mho/m; $\epsilon_r = 54.5$; $\rho = 1000$ kg/m³

Ambient Temperature : 22.3 °C ; Liquid Temperature : 21.3 °C

DASY4 Configuration:

- Probe: EX3DV4 - SN3792; ConvF(9.02, 9.02, 9.02); Calibrated: 2011/6/20
- Sensor-Surface: 4mm (Mechanical Surface Detection)
- Electronics: DAE4 Sn905; Calibrated: 2011/6/24
- Phantom: SAM-Left; Type: QD 000 P40 C; Serial: TP-1478
- Measurement SW: DASY4, V4.7 Build 80; Postprocessing SW: SEMCAD, V1.8 Build 186

Ch384/Area Scan (61x101x1): Measurement grid: dx=15mm, dy=15mm

Maximum value of SAR (interpolated) = 1.15 mW/g

Ch384/Zoom Scan (5x5x7)/Cube 0: Measurement grid: dx=8mm, dy=8mm, dz=5mm

Reference Value = 33.4 V/m; Power Drift = 0.010 dB

Peak SAR (extrapolated) = 1.39 W/kg

SAR(1 g) = 1.1 mW/g; SAR(10 g) = 0.824 mW/g

Maximum value of SAR (measured) = 1.15 mW/g

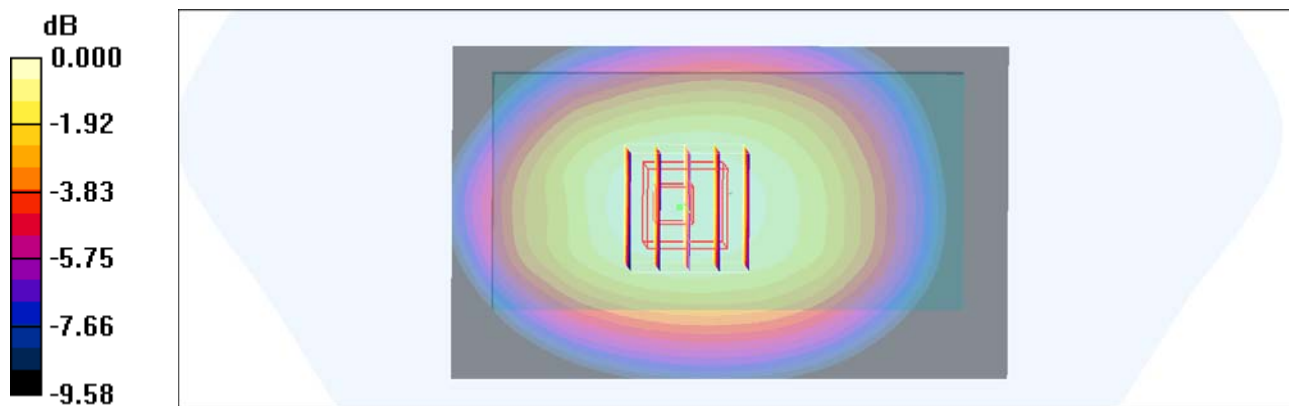

0 dB = 1.15mW/g

#24 CDMA2000 BC0_RC3+SO32_Back_1cm_Ch384_2D

DUT: 190327

Communication System: CDMA ; Frequency: 836.52 MHz;Duty Cycle: 1:1

Medium: MSL_850_110923 Medium parameters used: $f = 837$ MHz; $\sigma = 0.965$ mho/m; $\epsilon_r = 54.5$; $\rho = 1000$ kg/m³

Ambient Temperature : 22.3 °C ; Liquid Temperature : 21.3 °C

DASY4 Configuration:

- Probe: EX3DV4 - SN3792; ConvF(9.02, 9.02, 9.02); Calibrated: 2011/6/20
- Sensor-Surface: 4mm (Mechanical Surface Detection)
- Electronics: DAE4 Sn905; Calibrated: 2011/6/24
- Phantom: SAM-Left; Type: QD 000 P40 C; Serial: TP-1478
- Measurement SW: DASY4, V4.7 Build 80; Postprocessing SW: SEMCAD, V1.8 Build 186

Ch384/Area Scan (61x101x1): Measurement grid: dx=15mm, dy=15mm

Maximum value of SAR (interpolated) = 1.15 mW/g

Ch384/Zoom Scan (5x5x7)/Cube 0: Measurement grid: dx=8mm, dy=8mm, dz=5mm

Reference Value = 33.4 V/m; Power Drift = 0.010 dB

Peak SAR (extrapolated) = 1.39 W/kg

SAR(1 g) = 1.1 mW/g; SAR(10 g) = 0.824 mW/g

Maximum value of SAR (measured) = 1.15 mW/g

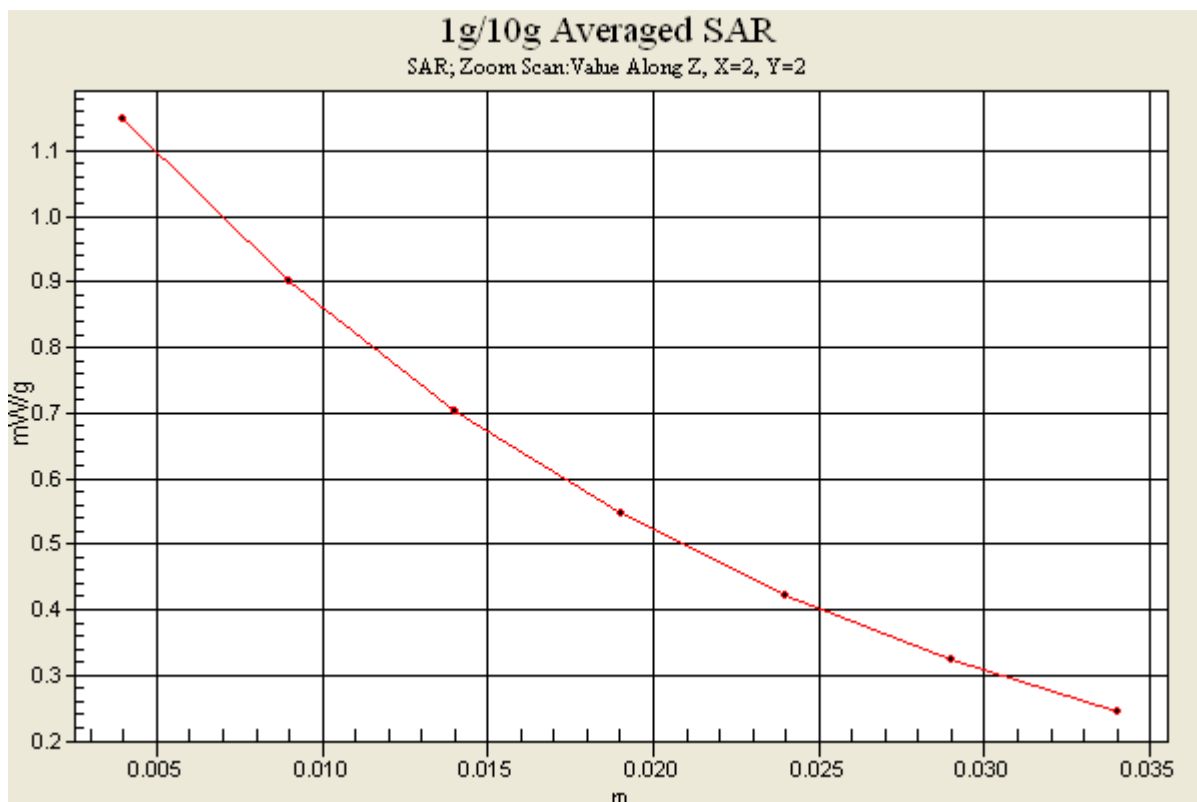

#25 CDMA2000 BC0_RC3+SO32_Back_1cm_Ch777

DUT: 190327

Communication System: CDMA ; Frequency: 848.31 MHz;Duty Cycle: 1:1

Medium: MSL_850_110923 Medium parameters used: $f = 848.31$ MHz; $\sigma = 0.976$ mho/m; $\epsilon_r = 54.4$;

$\rho = 1000$ kg/m³

Ambient Temperature : 22.3 °C ; Liquid Temperature : 21.3 °C

DASY4 Configuration:

- Probe: EX3DV4 - SN3792; ConvF(9.02, 9.02, 9.02); Calibrated: 2011/6/20
- Sensor-Surface: 4mm (Mechanical Surface Detection)
- Electronics: DAE4 Sn905; Calibrated: 2011/6/24
- Phantom: SAM-Left; Type: QD 000 P40 C; Serial: TP-1478
- Measurement SW: DASY4, V4.7 Build 80; Postprocessing SW: SEMCAD, V1.8 Build 186

Ch777/Area Scan (61x101x1): Measurement grid: dx=15mm, dy=15mm

Maximum value of SAR (interpolated) = 0.830 mW/g

Ch777/Zoom Scan (5x5x7)/Cube 0: Measurement grid: dx=8mm, dy=8mm, dz=5mm

Reference Value = 28.7 V/m; Power Drift = -0.053 dB

Peak SAR (extrapolated) = 1.00 W/kg

SAR(1 g) = 0.793 mW/g; SAR(10 g) = 0.597 mW/g

Maximum value of SAR (measured) = 0.832 mW/g

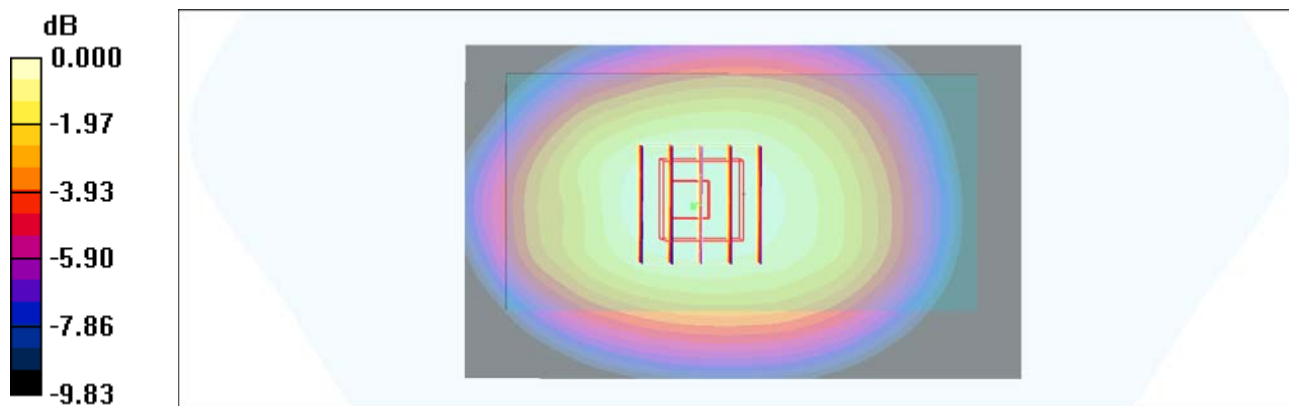

0 dB = 0.832mW/g

#26 CDMA2000 BC0_RC3+SO32_Back_1cm_Ch384_Earphone

DUT: 190327

Communication System: CDMA ; Frequency: 836.52 MHz;Duty Cycle: 1:1

Medium: MSL_850_110923 Medium parameters used: $f = 837$ MHz; $\sigma = 0.965$ mho/m; $\epsilon_r = 54.5$; $\rho = 1000$ kg/m³

Ambient Temperature : 22.3 °C ; Liquid Temperature : 21.3 °C

DASY4 Configuration:

- Probe: EX3DV4 - SN3792; ConvF(9.02, 9.02, 9.02); Calibrated: 2011/6/20
- Sensor-Surface: 4mm (Mechanical Surface Detection)
- Electronics: DAE4 Sn905; Calibrated: 2011/6/24
- Phantom: SAM-Left; Type: QD 000 P40 C; Serial: TP-1478
- Measurement SW: DASY4, V4.7 Build 80; Postprocessing SW: SEMCAD, V1.8 Build 186

Ch384/Area Scan (61x101x1): Measurement grid: dx=15mm, dy=15mm

Maximum value of SAR (interpolated) = 0.913 mW/g

Ch384/Zoom Scan (5x5x7)/Cube 0: Measurement grid: dx=8mm, dy=8mm, dz=5mm

Reference Value = 27.8 V/m; Power Drift = 0.010 dB

Peak SAR (extrapolated) = 1.11 W/kg

SAR(1 g) = 0.853 mW/g; SAR(10 g) = 0.632 mW/g

Maximum value of SAR (measured) = 0.892 mW/g

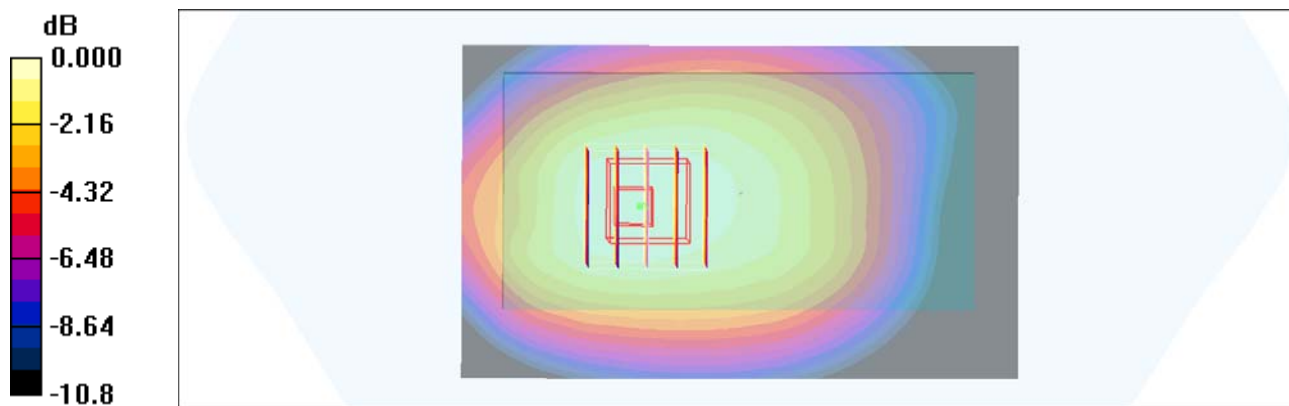

0 dB = 0.892mW/g

#27 CDMA2000 BC0_RC3+SO32_Back_1cm_Ch1013_Earphone

DUT: 190327

Communication System: CDMA ; Frequency: 824.7 MHz; Duty Cycle: 1:1

Medium: MSL_850_110923 Medium parameters used: $f = 825$ MHz; $\sigma = 0.954$ mho/m; $\epsilon_r = 54.7$; $\rho = 1000$ kg/m³

Ambient Temperature : 22.3 °C ; Liquid Temperature : 21.3 °C

DASY4 Configuration:

- Probe: EX3DV4 - SN3792; ConvF(9.02, 9.02, 9.02); Calibrated: 2011/6/20
- Sensor-Surface: 4mm (Mechanical Surface Detection)
- Electronics: DAE4 Sn905; Calibrated: 2011/6/24
- Phantom: SAM-Left; Type: QD 000 P40 C; Serial: TP-1478
- Measurement SW: DASY4, V4.7 Build 80; Postprocessing SW: SEMCAD, V1.8 Build 186

Ch1013/Area Scan (61x101x1): Measurement grid: dx=15mm, dy=15mm

Maximum value of SAR (interpolated) = 0.827 mW/g

Ch1013/Zoom Scan (5x5x7)/Cube 0: Measurement grid: dx=8mm, dy=8mm, dz=5mm

Reference Value = 26.6 V/m; Power Drift = -0.194 dB

Peak SAR (extrapolated) = 1.01 W/kg

SAR(1 g) = 0.777 mW/g; SAR(10 g) = 0.576 mW/g

Maximum value of SAR (measured) = 0.817 mW/g

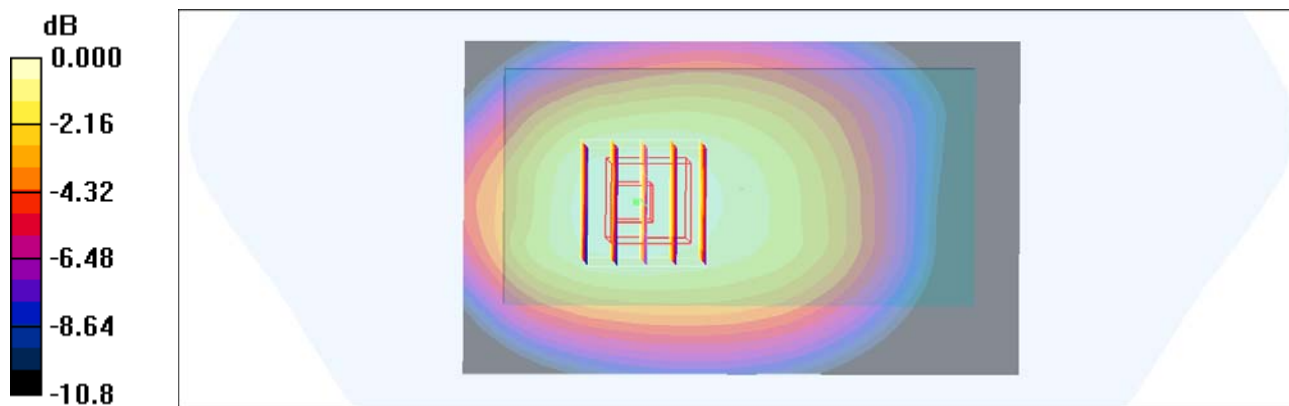

0 dB = 0.817mW/g

#28 CDMA2000 BC0_RC3+SO32_Back_1cm_Ch777_Earphone

DUT: 190327

Communication System: CDMA ; Frequency: 848.31 MHz;Duty Cycle: 1:1

Medium: MSL_850_110923 Medium parameters used: $f = 848.31$ MHz; $\sigma = 0.976$ mho/m; $\epsilon_r = 54.4$;

$\rho = 1000$ kg/m³

Ambient Temperature : 22.3 °C ; Liquid Temperature : 21.3 °C

DASY4 Configuration:

- Probe: EX3DV4 - SN3792; ConvF(9.02, 9.02, 9.02); Calibrated: 2011/6/20
- Sensor-Surface: 4mm (Mechanical Surface Detection)
- Electronics: DAE4 Sn905; Calibrated: 2011/6/24
- Phantom: SAM-Left; Type: QD 000 P40 C; Serial: TP-1478
- Measurement SW: DASY4, V4.7 Build 80; Postprocessing SW: SEMCAD, V1.8 Build 186

Ch777/Area Scan (61x101x1): Measurement grid: dx=15mm, dy=15mm

Maximum value of SAR (interpolated) = 0.603 mW/g

Ch777/Zoom Scan (5x5x7)/Cube 0: Measurement grid: dx=8mm, dy=8mm, dz=5mm

Reference Value = 22.7 V/m; Power Drift = 0.040 dB

Peak SAR (extrapolated) = 0.741 W/kg

SAR(1 g) = 0.573 mW/g; SAR(10 g) = 0.426 mW/g

Maximum value of SAR (measured) = 0.601 mW/g

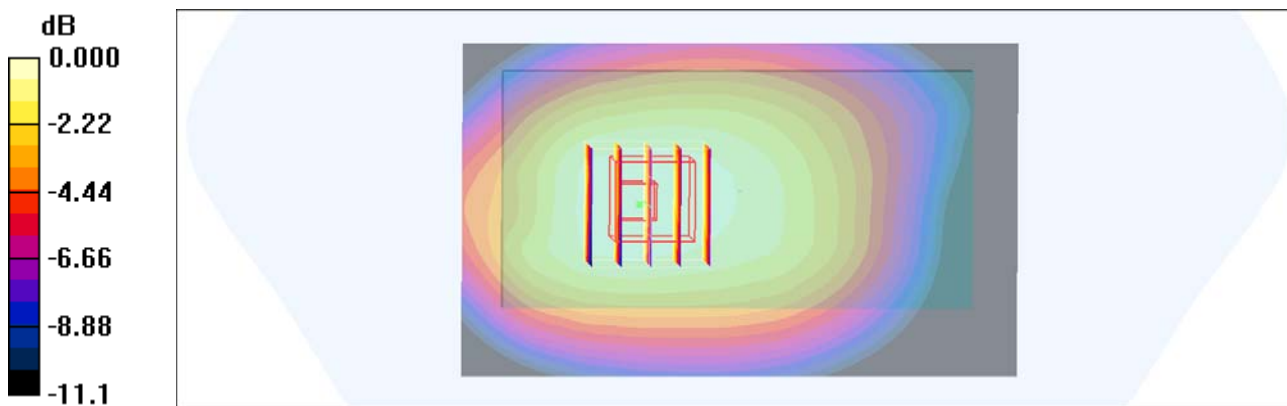

0 dB = 0.601mW/g

#29 802.11b_Right Check_Ch1

DUT: 190327

Communication System: 802.11b; Frequency: 2412 MHz; Duty Cycle: 1:1

Medium: HSL_2450_110928 Medium parameters used: $f = 2412$ MHz; $\sigma = 1.814$ mho/m; $\epsilon_r =$

39.405 ; $\rho = 1000$ kg/m³

Ambient Temperature : 22.3 °C ; Liquid Temperature : 21.3 °C

DASY5 Configuration:

- Probe: EX3DV4 - SN3792; ConvF(6.92, 6.92, 6.92); Calibrated: 2011/6/20
- Sensor-Surface: 4mm (Mechanical Surface Detection)
- Electronics: DAE4 Sn1279; Calibrated: 2011/6/17
- Phantom: SAM Left; Type: QD000P40CD; Serial: TP:1542
- Measurement SW: DASY52, Version 52.6 (2); SEMCAD X Version 14.4.5 (3634)

Ch1/Area Scan (61x101x1): Measurement grid: dx=15mm, dy=15mm

Maximum value of SAR (interpolated) = 0.521 mW/g

Ch1/Zoom Scan (5x5x7)/Cube 0: Measurement grid: dx=8mm, dy=8mm, dz=5mm

Reference Value = 14.887 V/m; Power Drift = -0.01 dB

Peak SAR (extrapolated) = 0.869 W/kg

SAR(1 g) = 0.435 mW/g; SAR(10 g) = 0.215 mW/g

Maximum value of SAR (measured) = 0.488 mW/g

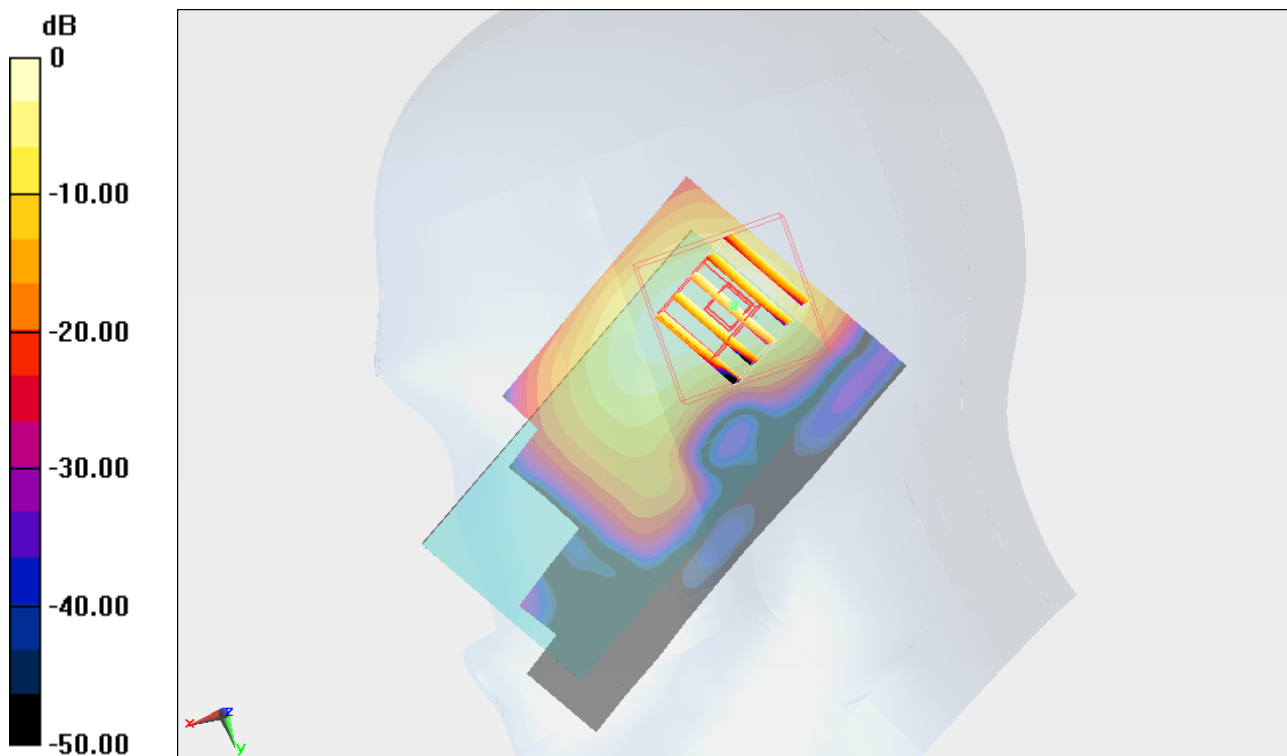

0 dB = 0.490mW/g

#29 802.11b_Right Check_Ch1_2D

DUT: 190327

Communication System: 802.11b; Frequency: 2412 MHz; Duty Cycle: 1:1
Medium: HSL_2450_110928 Medium parameters used: $f = 2412$ MHz; $\sigma = 1.814$ mho/m; $\epsilon_r = 39.405$; $\rho = 1000$ kg/m³
Ambient Temperature : 22.3 °C ; Liquid Temperature : 21.3 °C

DASY5 Configuration:

- Probe: EX3DV4 - SN3792; ConvF(6.92, 6.92, 6.92); Calibrated: 2011/6/20
- Sensor-Surface: 4mm (Mechanical Surface Detection)
- Electronics: DAE4 Sn1279; Calibrated: 2011/6/17
- Phantom: SAM Left; Type: QD000P40CD; Serial: TP:1542
- Measurement SW: DASY52, Version 52.6 (2); SEMCAD X Version 14.4.5 (3634)

Ch1/Area Scan (61x101x1): Measurement grid: dx=15mm, dy=15mm
Maximum value of SAR (interpolated) = 0.521 mW/g

Ch1/Zoom Scan (5x5x7)/Cube 0: Measurement grid: dx=8mm, dy=8mm, dz=5mm
Reference Value = 14.887 V/m; Power Drift = -0.01 dB
Peak SAR (extrapolated) = 0.869 W/kg
SAR(1 g) = 0.435 mW/g; SAR(10 g) = 0.215 mW/g
Maximum value of SAR (measured) = 0.488 mW/g

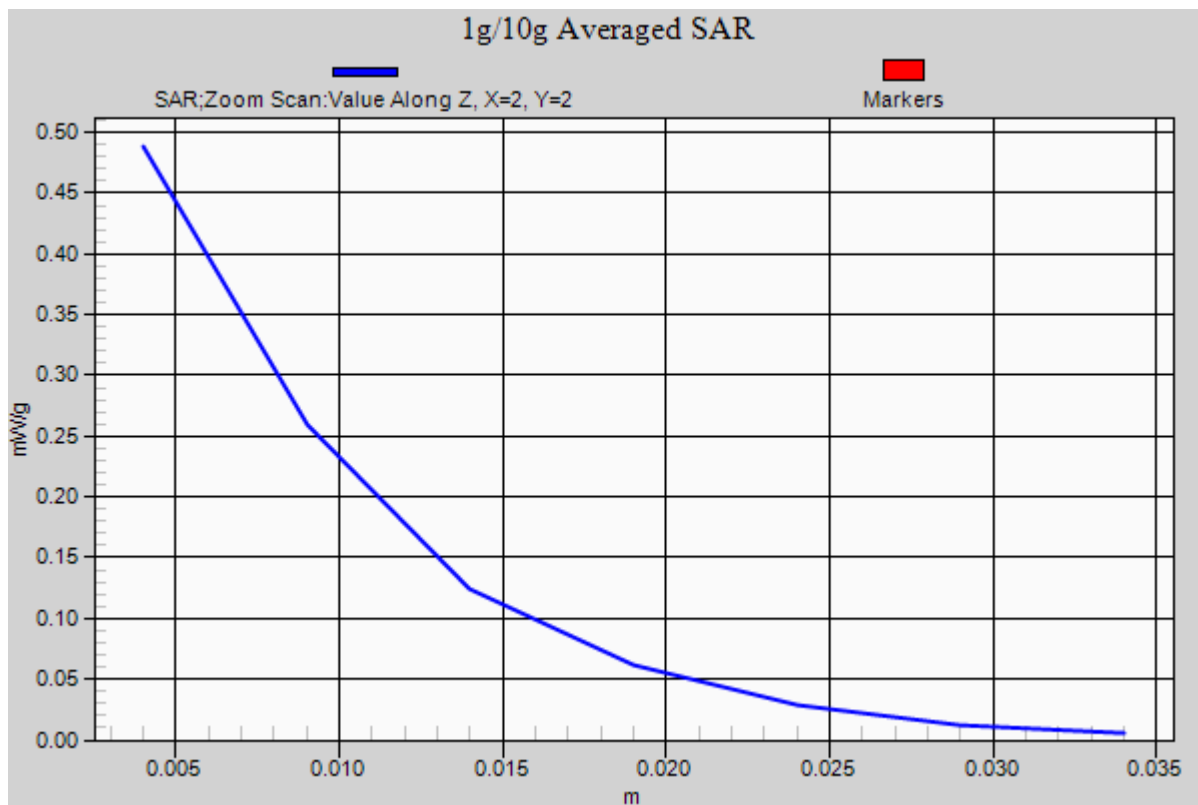

#30 802.11b_Right Tilted_Ch1

DUT: 190327

Communication System: 802.11b; Frequency: 2412 MHz; Duty Cycle: 1:1

Medium: HSL_2450_110928 Medium parameters used: $f = 2412$ MHz; $\sigma = 1.814$ mho/m; $\epsilon_r =$

39.405 ; $\rho = 1000$ kg/m³

Ambient Temperature : 22.3 °C ; Liquid Temperature : 21.3 °C

DASY5 Configuration:

- Probe: EX3DV4 - SN3792; ConvF(6.92, 6.92, 6.92); Calibrated: 2011/6/20
- Sensor-Surface: 4mm (Mechanical Surface Detection)
- Electronics: DAE4 Sn1279; Calibrated: 2011/6/17
- Phantom: SAM Left; Type: QD000P40CD; Serial: TP:1542
- Measurement SW: DASY52, Version 52.6 (2); SEMCAD X Version 14.4.5 (3634)

Ch1/Area Scan (61x101x1): Measurement grid: dx=15mm, dy=15mm

Maximum value of SAR (interpolated) = 0.473 mW/g

Ch1/Zoom Scan (5x5x7)/Cube 0: Measurement grid: dx=8mm, dy=8mm, dz=5mm

Reference Value = 12.879 V/m; Power Drift = 0.03 dB

Peak SAR (extrapolated) = 0.761 W/kg

SAR(1 g) = 0.373 mW/g; SAR(10 g) = 0.176 mW/g

Maximum value of SAR (measured) = 0.414 mW/g

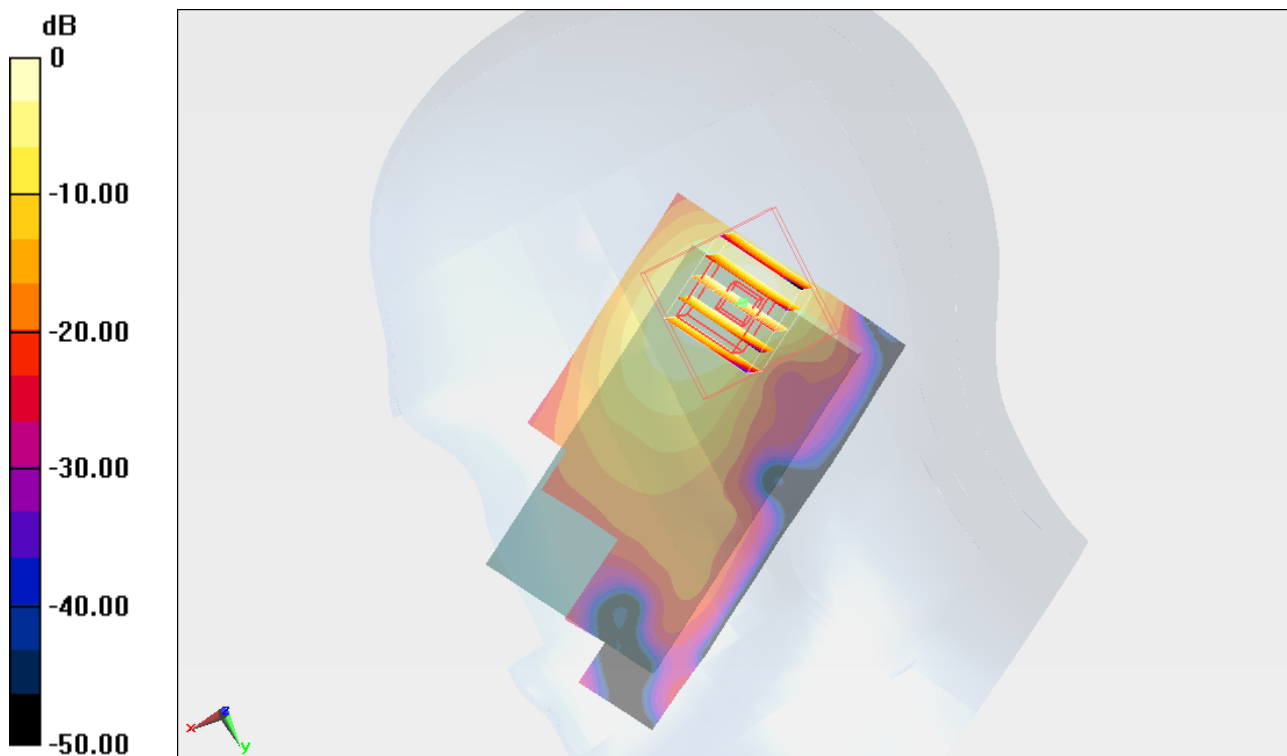

0 dB = 0.410mW/g

#31 802.11b_Left Cheek_Ch1

DUT: 190327

Communication System: 802.11b; Frequency: 2412 MHz; Duty Cycle: 1:1

Medium: HSL_2450_110928 Medium parameters used: $f = 2412$ MHz; $\sigma = 1.814$ mho/m; $\epsilon_r =$

39.405 ; $\rho = 1000$ kg/m³

Ambient Temperature : 22.3 °C ; Liquid Temperature : 21.3 °C

DASY5 Configuration:

- Probe: EX3DV4 - SN3792; ConvF(6.92, 6.92, 6.92); Calibrated: 2011/6/20
- Sensor-Surface: 4mm (Mechanical Surface Detection)
- Electronics: DAE4 Sn1279; Calibrated: 2011/6/17
- Phantom: SAM Left; Type: QD000P40CD; Serial: TP:1542
- Measurement SW: DASY52, Version 52.6 (2); SEMCAD X Version 14.4.5 (3634)

Ch1/Area Scan (61x101x1): Measurement grid: dx=15mm, dy=15mm

Maximum value of SAR (interpolated) = 0.510 mW/g

Ch1/Zoom Scan (5x5x7)/Cube 0: Measurement grid: dx=8mm, dy=8mm, dz=5mm

Reference Value = 15.585 V/m; Power Drift = -0.02 dB

Peak SAR (extrapolated) = 0.862 W/kg

SAR(1 g) = 0.402 mW/g; SAR(10 g) = 0.180 mW/g

Maximum value of SAR (measured) = 0.451 mW/g

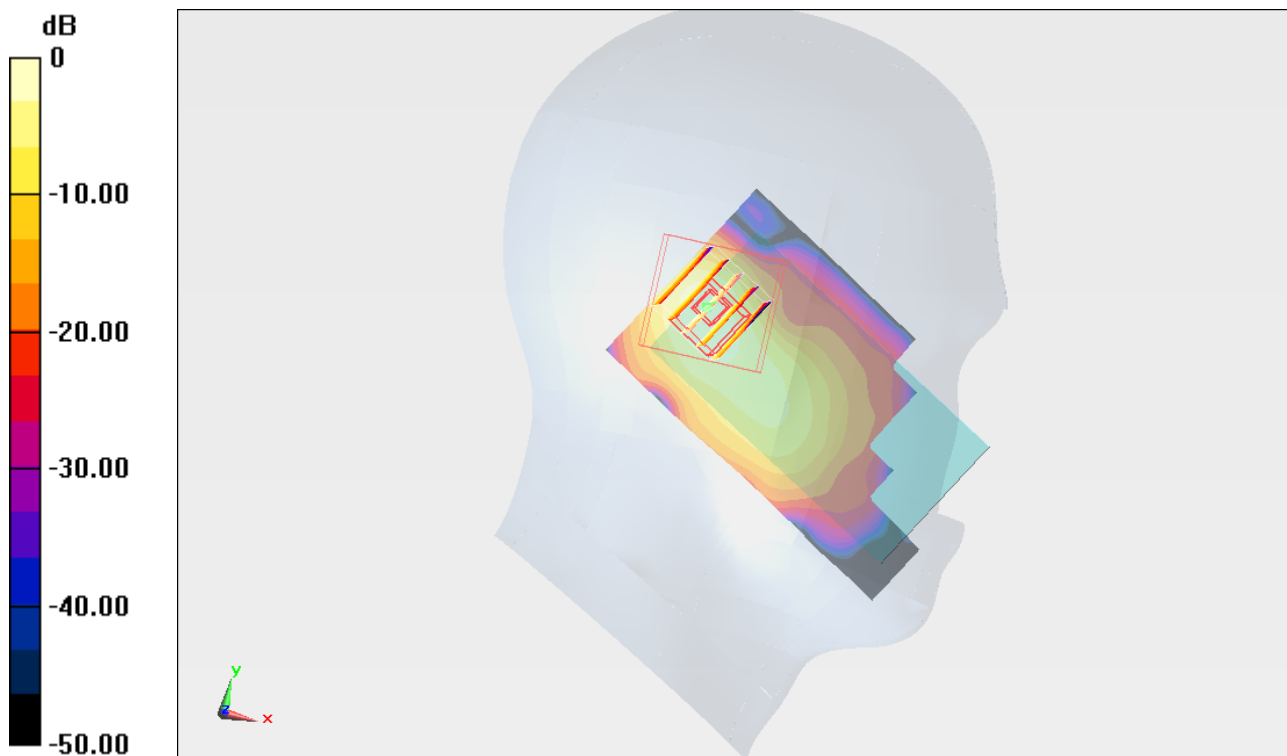

0 dB = 0.450mW/g

#32 802.11b_Left Tilted_Ch1

DUT: 190327

Communication System: 802.11b; Frequency: 2412 MHz; Duty Cycle: 1:1

Medium: HSL_2450_110928 Medium parameters used: $f = 2412$ MHz; $\sigma = 1.814$ mho/m; $\epsilon_r =$

39.405 ; $\rho = 1000$ kg/m³

Ambient Temperature : 22.3 °C ; Liquid Temperature : 21.3 °C

DASY5 Configuration:

- Probe: EX3DV4 - SN3792; ConvF(6.92, 6.92, 6.92); Calibrated: 2011/6/20
- Sensor-Surface: 4mm (Mechanical Surface Detection)
- Electronics: DAE4 Sn1279; Calibrated: 2011/6/17
- Phantom: SAM Left; Type: QD000P40CD; Serial: TP:1542
- Measurement SW: DASY52, Version 52.6 (2); SEMCAD X Version 14.4.5 (3634)

Ch1/Area Scan (61x101x1): Measurement grid: dx=15mm, dy=15mm

Maximum value of SAR (interpolated) = 0.451 mW/g

Ch1/Zoom Scan (5x5x7)/Cube 0: Measurement grid: dx=8mm, dy=8mm, dz=5mm

Reference Value = 13.990 V/m; Power Drift = 0.03 dB

Peak SAR (extrapolated) = 0.748 W/kg

SAR(1 g) = 0.355 mW/g; SAR(10 g) = 0.163 mW/g

Maximum value of SAR (measured) = 0.392 mW/g

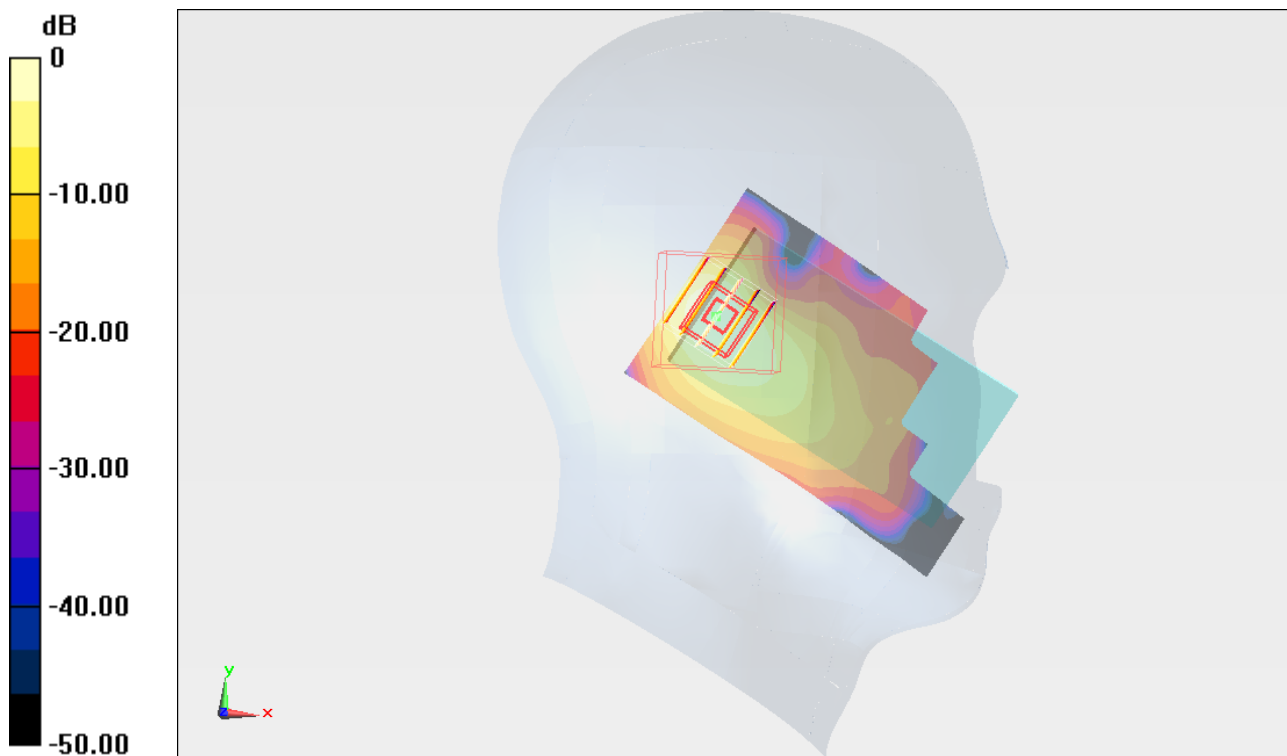

0 dB = 0.390mW/g

#33 802.11b_Front_1cm_Ch1

DUT: 190327

Communication System: 802.11b; Frequency: 2412 MHz; Duty Cycle: 1:1

Medium: MSL_2450_110928 Medium parameters used: $f = 2412 \text{ MHz}$; $\sigma = 1.91 \text{ mho/m}$; $\epsilon_r = 54.765$;

$\rho = 1000 \text{ kg/m}^3$

Ambient Temperature : 22.5 °C ; Liquid Temperature : 21.5 °C

DASY5 Configuration:

- Probe: EX3DV4 - SN3792; ConvF(6.67, 6.67, 6.67); Calibrated: 2011/6/20
- Sensor-Surface: 4mm (Mechanical Surface Detection)
- Electronics: DAE4 Sn1279; Calibrated: 2011/6/17
- Phantom: SAM Right; Type: QD000P40CD; Serial: TP:1644
- Measurement SW: DASY52, Version 52.6 (2); SEMCAD X Version 14.4.5 (3634)

Ch1/Area Scan (61x101x1): Measurement grid: $dx=15\text{mm}$, $dy=15\text{mm}$

Maximum value of SAR (interpolated) = 0.145 mW/g

Ch1/Zoom Scan (5x5x7)/Cube 0: Measurement grid: $dx=8\text{mm}$, $dy=8\text{mm}$, $dz=5\text{mm}$

Reference Value = 2.591 V/m; Power Drift = 0.140 dB

Peak SAR (extrapolated) = 0.237 W/kg

SAR(1 g) = 0.127 mW/g; SAR(10 g) = 0.067 mW/g

Maximum value of SAR (measured) = 0.138 mW/g

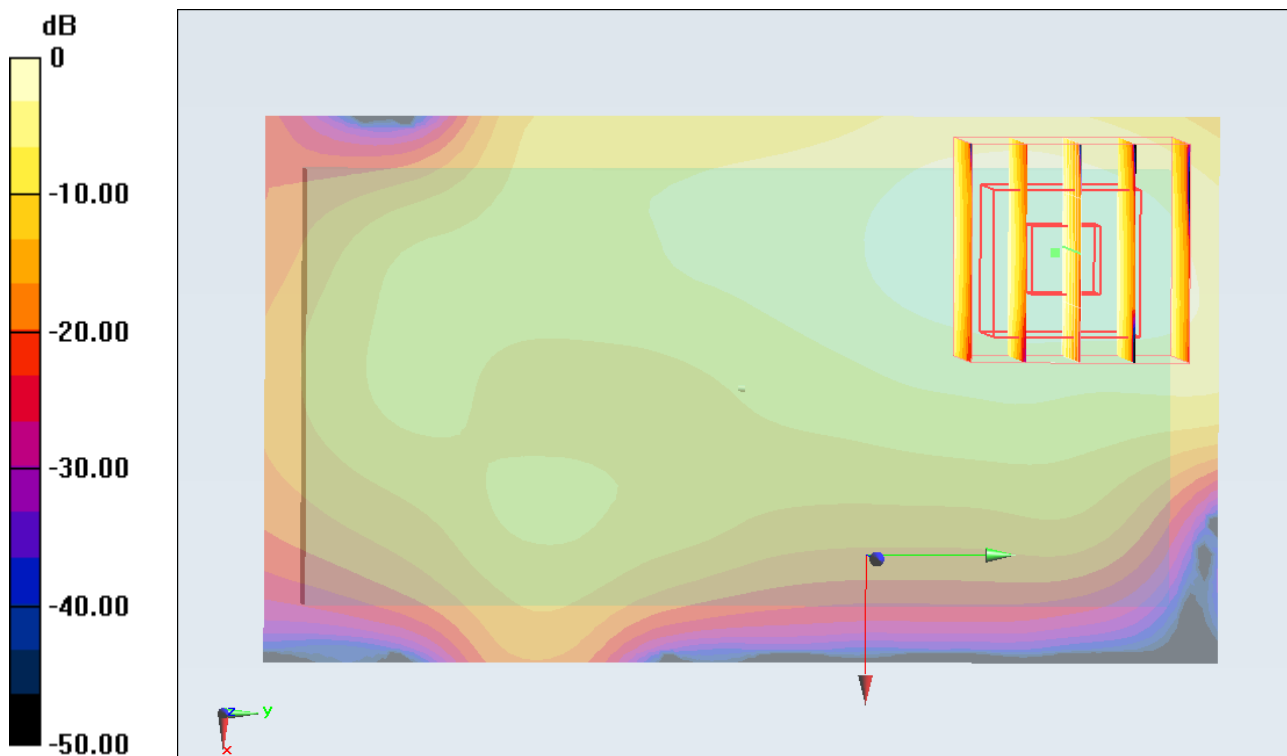

0 dB = 0.140mW/g

#34 802.11b_Back_1cm_Ch1

DUT: 190327

Communication System: 802.11b; Frequency: 2412 MHz; Duty Cycle: 1:1

Medium: MSL_2450_110928 Medium parameters used: $f = 2412$ MHz; $\sigma = 1.91$ mho/m; $\epsilon_r = 54.765$;

$\rho = 1000$ kg/m³

Ambient Temperature : 22.5 °C ; Liquid Temperature : 21.5 °C

DASY5 Configuration:

- Probe: EX3DV4 - SN3792; ConvF(6.67, 6.67, 6.67); Calibrated: 2011/6/20
- Sensor-Surface: 4mm (Mechanical Surface Detection)
- Electronics: DAE4 Sn1279; Calibrated: 2011/6/17
- Phantom: SAM Right; Type: QD000P40CD; Serial: TP:1644
- Measurement SW: DASY52, Version 52.6 (2); SEMCAD X Version 14.4.5 (3634)

Ch1/Area Scan (61x101x1): Measurement grid: dx=15mm, dy=15mm

Maximum value of SAR (interpolated) = 0.129 mW/g

Ch1/Zoom Scan (5x5x7)/Cube 0: Measurement grid: dx=8mm, dy=8mm, dz=5mm

Reference Value = 3.017 V/m; Power Drift = 0.154 dB

Peak SAR (extrapolated) = 0.248 W/kg

SAR(1 g) = 0.128 mW/g; SAR(10 g) = 0.065 mW/g

Maximum value of SAR (measured) = 0.139 mW/g

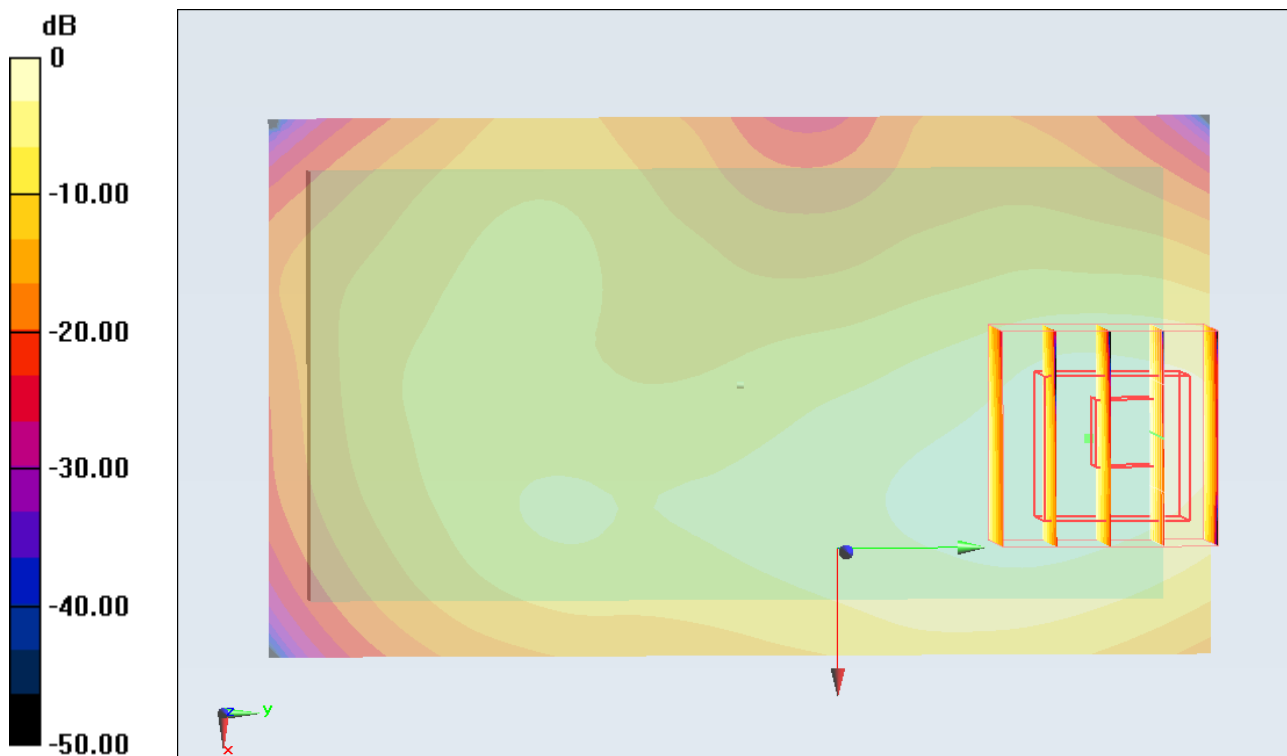

0 dB = 0.140mW/g

#34 802.11b_Back_1cm_Ch1_2D

DUT: 190327

Communication System: 802.11b; Frequency: 2412 MHz; Duty Cycle: 1:1
Medium: MSL_2450_110928 Medium parameters used: $f = 2412 \text{ MHz}$; $\sigma = 1.91 \text{ mho/m}$; $\epsilon_r = 54.765$; $\rho = 1000 \text{ kg/m}^3$
Ambient Temperature : 22.5 °C ; Liquid Temperature : 21.5 °C

DASY5 Configuration:

- Probe: EX3DV4 - SN3792; ConvF(6.67, 6.67, 6.67); Calibrated: 2011/6/20
- Sensor-Surface: 4mm (Mechanical Surface Detection)
- Electronics: DAE4 Sn1279; Calibrated: 2011/6/17
- Phantom: SAM Right; Type: QD000P40CD; Serial: TP:1644
- Measurement SW: DASY52, Version 52.6 (2); SEMCAD X Version 14.4.5 (3634)

Ch1/Area Scan (61x101x1): Measurement grid: dx=15mm, dy=15mm
Maximum value of SAR (interpolated) = 0.129 mW/g

Ch1/Zoom Scan (5x5x7)/Cube 0: Measurement grid: dx=8mm, dy=8mm, dz=5mm
Reference Value = 3.017 V/m; Power Drift = 0.154 dB
Peak SAR (extrapolated) = 0.248 W/kg
SAR(1 g) = 0.128 mW/g; SAR(10 g) = 0.065 mW/g
Maximum value of SAR (measured) = 0.139 mW/g

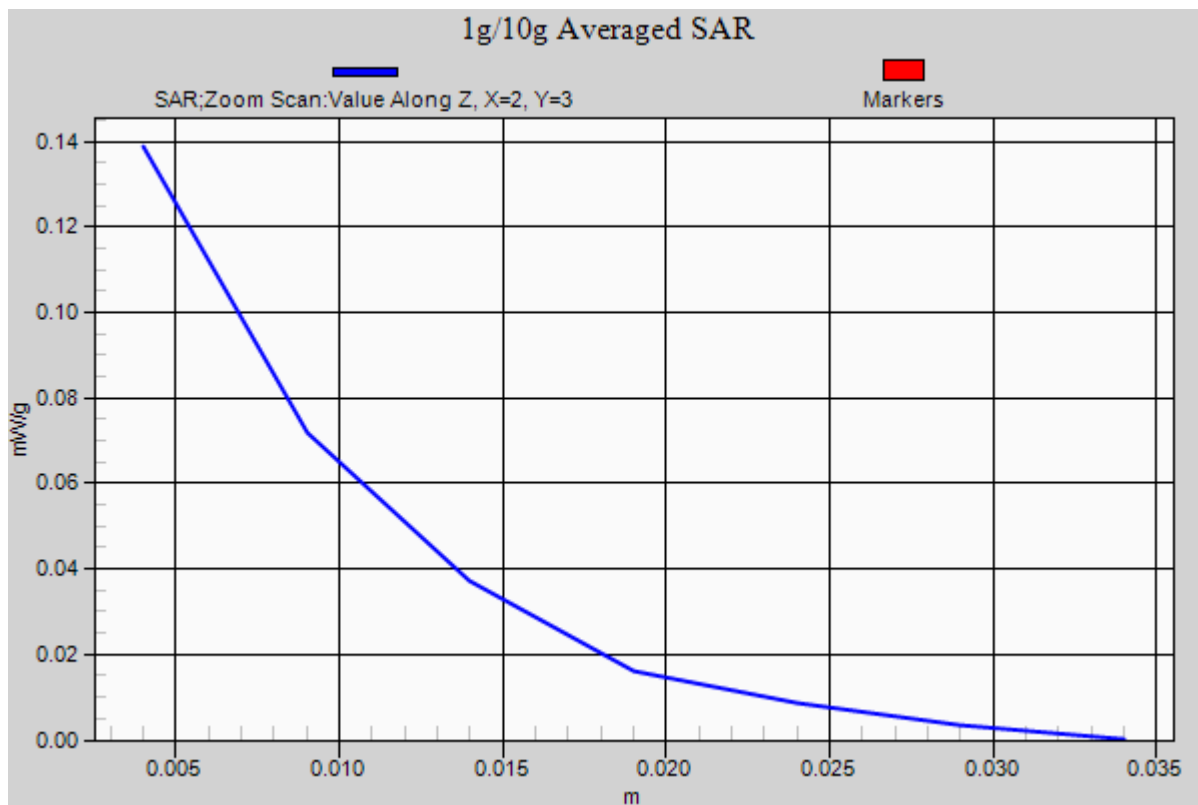

#35 802.11b_Left Side_1cm_Ch1

DUT: 190327

Communication System: 802.11b; Frequency: 2412 MHz; Duty Cycle: 1:1

Medium: MSL_2450_110928 Medium parameters used: $f = 2412$ MHz; $\sigma = 1.91$ mho/m; $\epsilon_r = 54.765$;

$\rho = 1000$ kg/m³

Ambient Temperature : 22.5 °C; Liquid Temperature : 21.5 °C

DASY5 Configuration:

- Probe: EX3DV4 - SN3792; ConvF(6.67, 6.67, 6.67); Calibrated: 2011/6/20
- Sensor-Surface: 4mm (Mechanical Surface Detection)
- Electronics: DAE4 Sn1279; Calibrated: 2011/6/17
- Phantom: SAM Right; Type: QD000P40CD; Serial: TP:1644
- Measurement SW: DASY52, Version 52.6 (2); SEMCAD X Version 14.4.5 (3634)

Ch1/Area Scan (41x101x1): Measurement grid: dx=15mm, dy=15mm

Maximum value of SAR (interpolated) = 0.051 mW/g

Ch1/Zoom Scan (5x5x7)/Cube 0: Measurement grid: dx=8mm, dy=8mm, dz=5mm

Reference Value = 3.791 V/m; Power Drift = 0.05 dB

Peak SAR (extrapolated) = 0.096 W/kg

SAR(1 g) = 0.052 mW/g; SAR(10 g) = 0.027 mW/g

Maximum value of SAR (measured) = 0.055 mW/g

Ch1/Zoom Scan (5x5x7)/Cube 1: Measurement grid: dx=8mm, dy=8mm, dz=5mm

Reference Value = 3.791 V/m; Power Drift = 0.05 dB

Peak SAR (extrapolated) = 0.070 W/kg

SAR(1 g) = 0.036 mW/g; SAR(10 g) = 0.019 mW/g

Maximum value of SAR (measured) = 0.038 mW/g

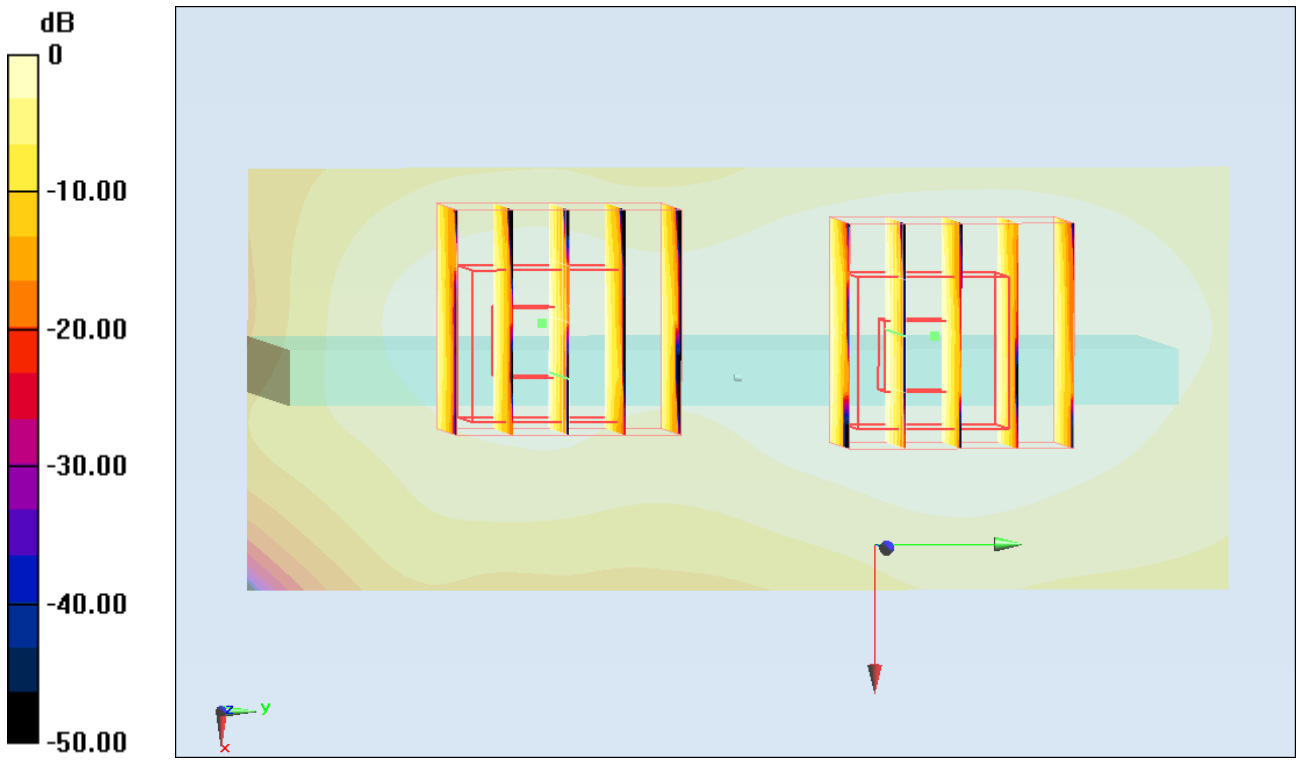

0 dB = 0.040mW/g

#36 802.11b_Right Side_1cm_Ch1

DUT: 190327

Communication System: 802.11b; Frequency: 2412 MHz; Duty Cycle: 1:1

Medium: MSL_2450_110928 Medium parameters used: $f = 2412$ MHz; $\sigma = 1.91$ mho/m; $\epsilon_r = 54.765$;

$\rho = 1000$ kg/m³

Ambient Temperature : 22.5 °C ; Liquid Temperature : 21.5 °C

DASY5 Configuration:

- Probe: EX3DV4 - SN3792; ConvF(6.67, 6.67, 6.67); Calibrated: 2011/6/20
- Sensor-Surface: 4mm (Mechanical Surface Detection)
- Electronics: DAE4 Sn1279; Calibrated: 2011/6/17
- Phantom: SAM Right; Type: QD000P40CD; Serial: TP:1644
- Measurement SW: DASY52, Version 52.6 (2); SEMCAD X Version 14.4.5 (3634)

Ch1/Area Scan (41x101x1): Measurement grid: dx=15mm, dy=15mm

Maximum value of SAR (interpolated) = 0.00163 mW/g

Ch1/Zoom Scan (5x5x7)/Cube 0: Measurement grid: dx=8mm, dy=8mm, dz=5mm

Reference Value = 0.247 V/m; Power Drift = 0.074 dB

Peak SAR (extrapolated) = 0.000702 W/kg

SAR(1 g) = 9.29e-006 mW/g; SAR(10 g) = 1.33e-006 mW/g

Maximum value of SAR (measured) = 0.00277 mW/g

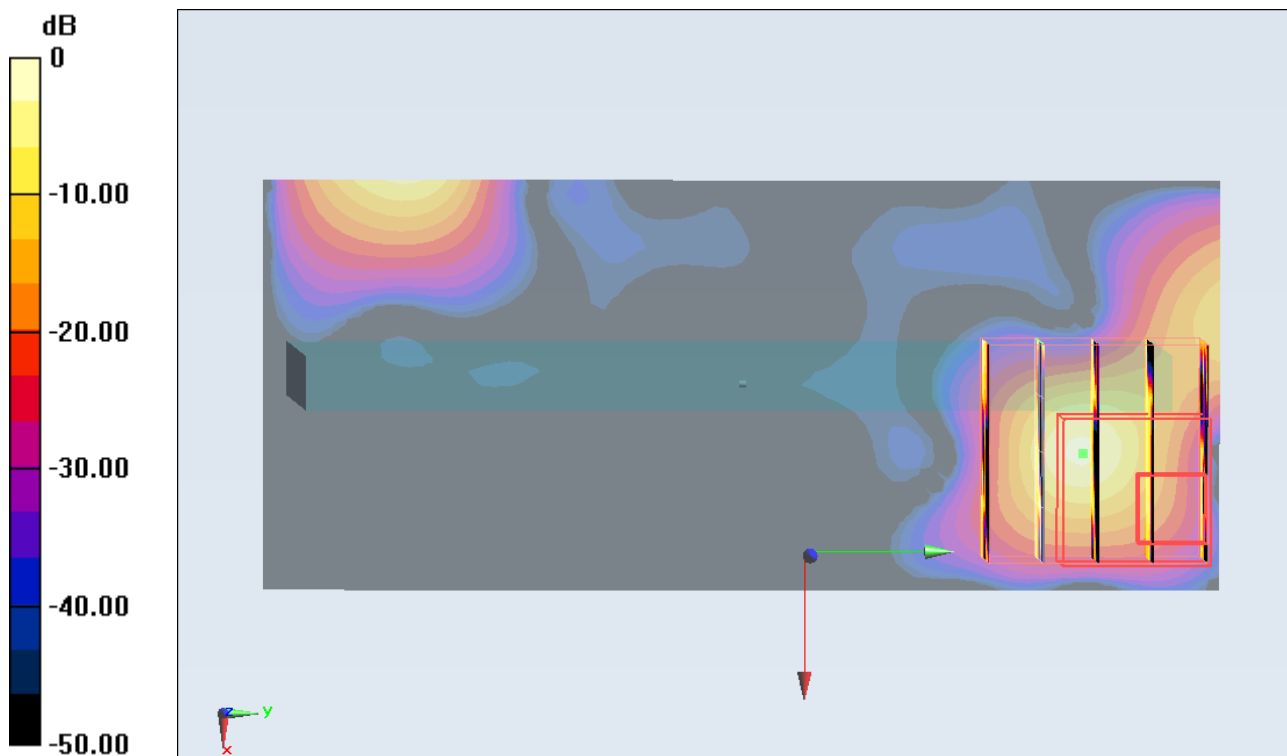

0 dB = 0.0028mW/g

#37 802.11b_Top Side_1cm_Ch1

DUT: 190327

Communication System: 802.11b; Frequency: 2412 MHz; Duty Cycle: 1:1

Medium: MSL_2450_110928 Medium parameters used: $f = 2412 \text{ MHz}$; $\sigma = 1.91 \text{ mho/m}$; $\epsilon_r = 54.765$;

$\rho = 1000 \text{ kg/m}^3$

Ambient Temperature : 22.5 °C ; Liquid Temperature : 21.5 °C

DASY5 Configuration:

- Probe: EX3DV4 - SN3792; ConvF(6.67, 6.67, 6.67); Calibrated: 2011/6/20
- Sensor-Surface: 4mm (Mechanical Surface Detection)
- Electronics: DAE4 Sn1279; Calibrated: 2011/6/17
- Phantom: SAM Right; Type: QD000P40CD; Serial: TP:1644
- Measurement SW: DASY52, Version 52.6 (2); SEMCAD X Version 14.4.5 (3634)

Ch1/Area Scan (31x51x1): Measurement grid: $dx=15\text{mm}$, $dy=15\text{mm}$

Maximum value of SAR (interpolated) = 0.081 mW/g

Ch1/Zoom Scan (5x5x7)/Cube 0: Measurement grid: $dx=8\text{mm}$, $dy=8\text{mm}$, $dz=5\text{mm}$

Reference Value = 4.839 V/m; Power Drift = 0.123 dB

Peak SAR (extrapolated) = 0.151 W/kg

SAR(1 g) = 0.076 mW/g; SAR(10 g) = 0.037 mW/g

Maximum value of SAR (measured) = 0.081 mW/g

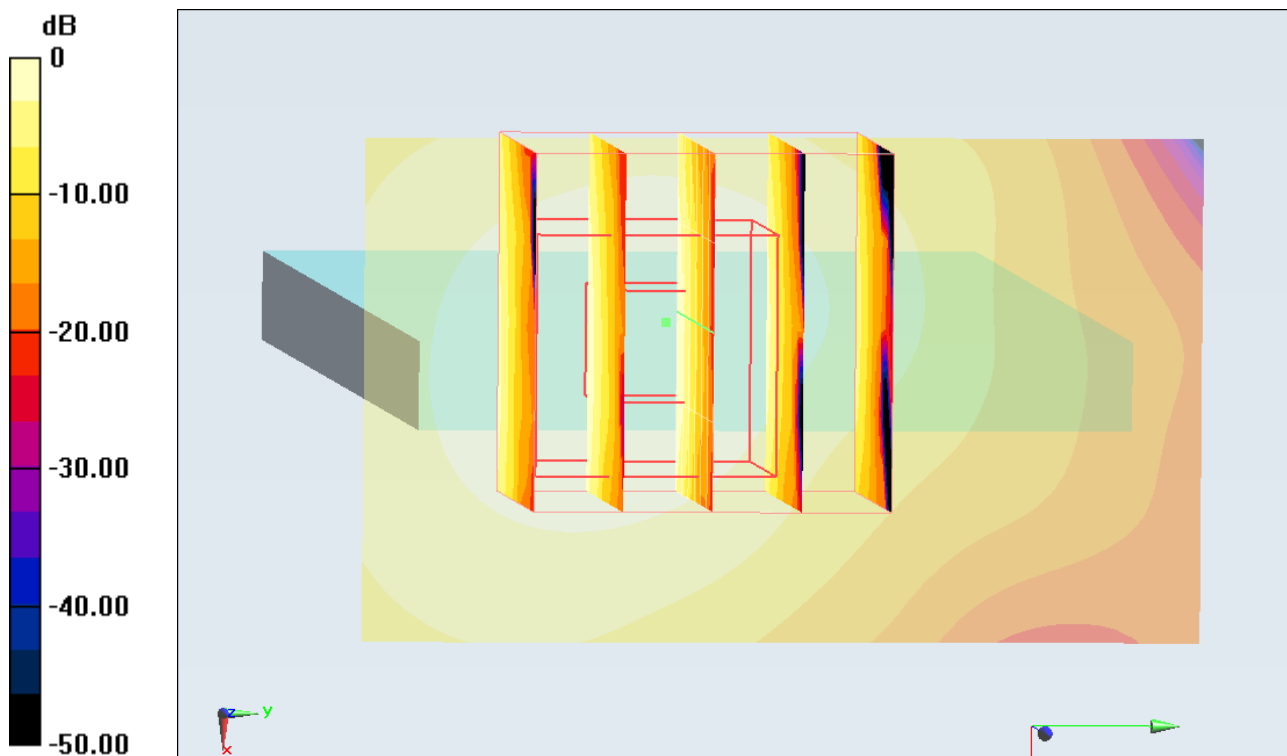

0 dB = 0.080mW/g

#38 802.11b_Bottom Side_1cm_Ch1

DUT: 190327

Communication System: 802.11b; Frequency: 2412 MHz; Duty Cycle: 1:1

Medium: MSL_2450_110928 Medium parameters used: $f = 2412 \text{ MHz}$; $\sigma = 1.91 \text{ mho/m}$; $\epsilon_r = 54.765$;

$\rho = 1000 \text{ kg/m}^3$

Ambient Temperature : 22.5 °C ; Liquid Temperature : 21.5 °C

DASY5 Configuration:

- Probe: EX3DV4 - SN3792; ConvF(6.67, 6.67, 6.67); Calibrated: 2011/6/20
- Sensor-Surface: 4mm (Mechanical Surface Detection)
- Electronics: DAE4 Sn1279; Calibrated: 2011/6/17
- Phantom: SAM Right; Type: QD000P40CD; Serial: TP:1644
- Measurement SW: DASY52, Version 52.6 (2); SEMCAD X Version 14.4.5 (3634)

Ch1/Area Scan (31x51x1): Measurement grid: $dx=15\text{mm}$, $dy=15\text{mm}$

Maximum value of SAR (interpolated) = 0.011 mW/g

Ch1/Zoom Scan (5x5x7)/Cube 0: Measurement grid: $dx=8\text{mm}$, $dy=8\text{mm}$, $dz=5\text{mm}$

Reference Value = 1.568 V/m; Power Drift = 0.131 dB

Peak SAR (extrapolated) = 0.013 W/kg

SAR(1 g) = 0.00589 mW/g; SAR(10 g) = 0.0025 mW/g

Maximum value of SAR (measured) = 0.00686 mW/g

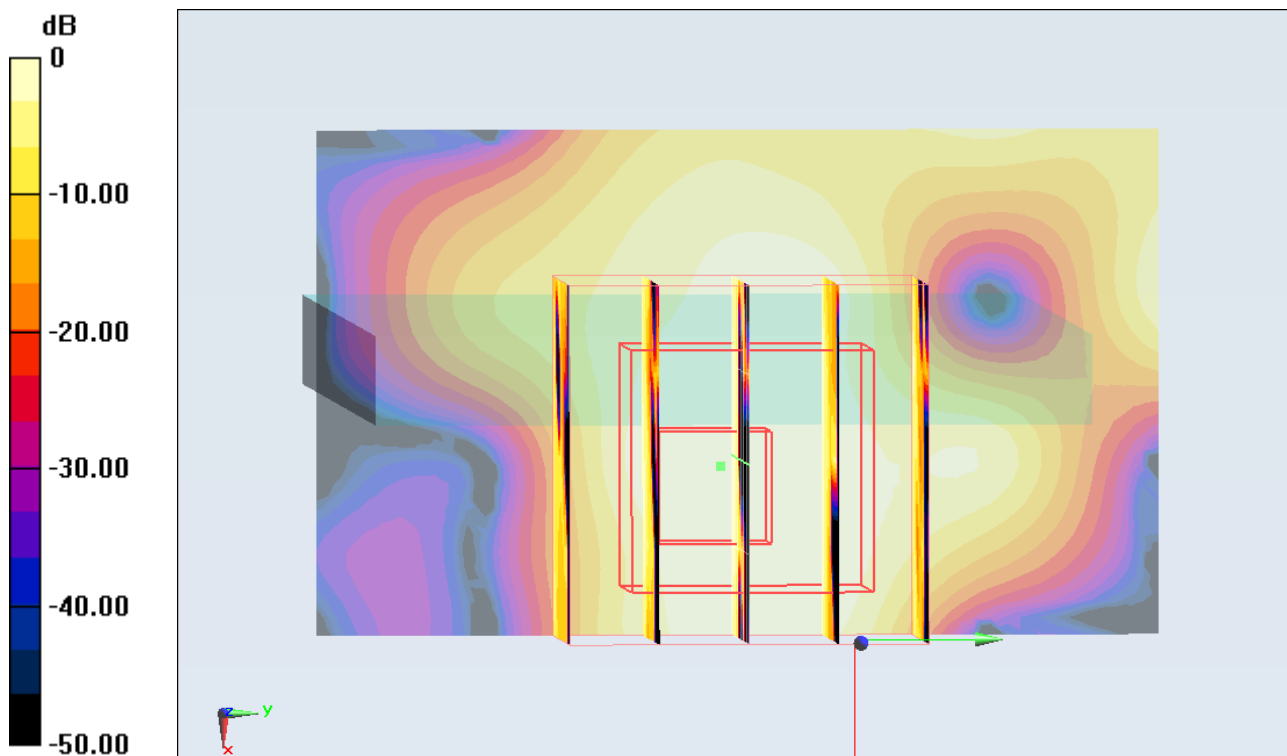

0 dB = 0.0069mW/g

#33 802.11b_Front_1cm_Ch1

DUT: 190327

Communication System: 802.11b; Frequency: 2412 MHz; Duty Cycle: 1:1

Medium: MSL_2450_110928 Medium parameters used: $f = 2412 \text{ MHz}$; $\sigma = 1.91 \text{ mho/m}$; $\epsilon_r = 54.765$;

$\rho = 1000 \text{ kg/m}^3$

Ambient Temperature : 22.5 °C ; Liquid Temperature : 21.5 °C

DASY5 Configuration:

- Probe: EX3DV4 - SN3792; ConvF(6.67, 6.67, 6.67); Calibrated: 2011/6/20
- Sensor-Surface: 4mm (Mechanical Surface Detection)
- Electronics: DAE4 Sn1279; Calibrated: 2011/6/17
- Phantom: SAM Right; Type: QD000P40CD; Serial: TP:1644
- Measurement SW: DASY52, Version 52.6 (2); SEMCAD X Version 14.4.5 (3634)

Ch1/Area Scan (61x101x1): Measurement grid: $dx=15\text{mm}$, $dy=15\text{mm}$

Maximum value of SAR (interpolated) = 0.145 mW/g

Ch1/Zoom Scan (5x5x7)/Cube 0: Measurement grid: $dx=8\text{mm}$, $dy=8\text{mm}$, $dz=5\text{mm}$

Reference Value = 2.591 V/m; Power Drift = 0.140 dB

Peak SAR (extrapolated) = 0.237 W/kg

SAR(1 g) = 0.127 mW/g; SAR(10 g) = 0.067 mW/g

Maximum value of SAR (measured) = 0.138 mW/g

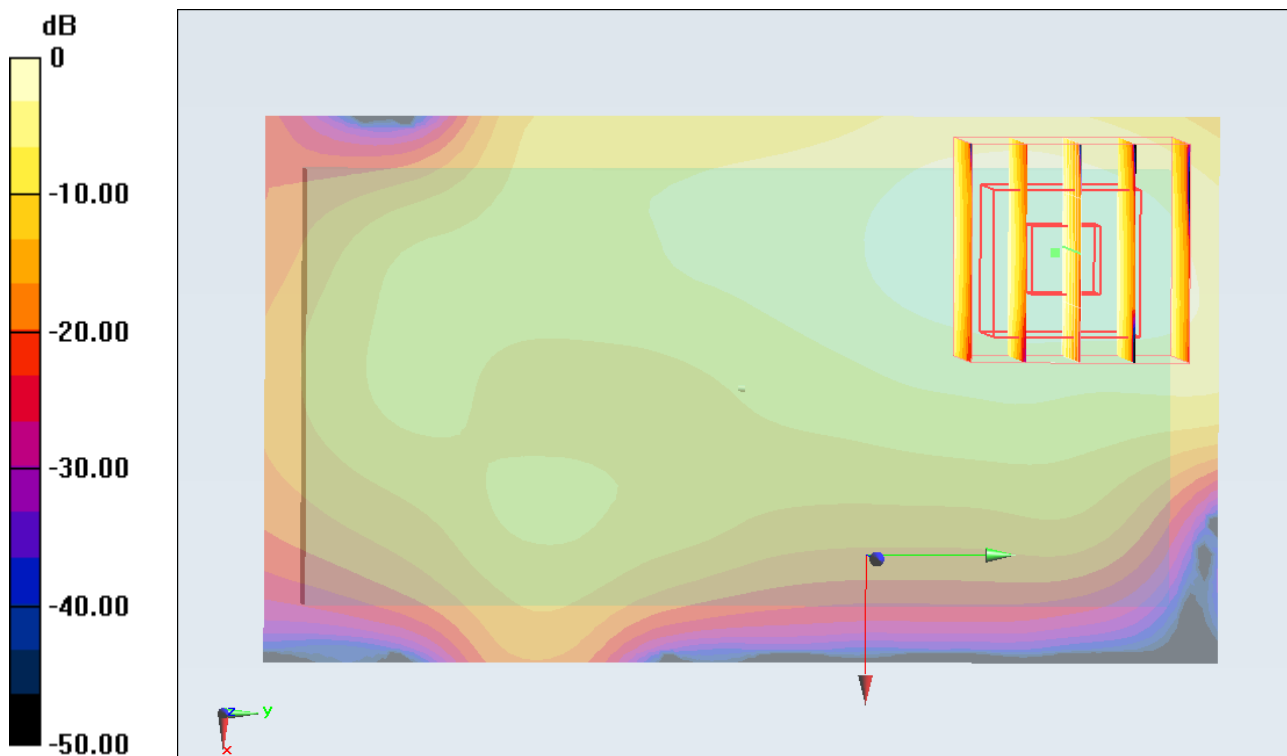

0 dB = 0.140mW/g

#34 802.11b_Back_1cm_Ch1

DUT: 190327

Communication System: 802.11b; Frequency: 2412 MHz; Duty Cycle: 1:1

Medium: MSL_2450_110928 Medium parameters used: $f = 2412$ MHz; $\sigma = 1.91$ mho/m; $\epsilon_r = 54.765$;

$\rho = 1000$ kg/m³

Ambient Temperature : 22.5 °C ; Liquid Temperature : 21.5 °C

DASY5 Configuration:

- Probe: EX3DV4 - SN3792; ConvF(6.67, 6.67, 6.67); Calibrated: 2011/6/20
- Sensor-Surface: 4mm (Mechanical Surface Detection)
- Electronics: DAE4 Sn1279; Calibrated: 2011/6/17
- Phantom: SAM Right; Type: QD000P40CD; Serial: TP:1644
- Measurement SW: DASY52, Version 52.6 (2); SEMCAD X Version 14.4.5 (3634)

Ch1/Area Scan (61x101x1): Measurement grid: dx=15mm, dy=15mm

Maximum value of SAR (interpolated) = 0.129 mW/g

Ch1/Zoom Scan (5x5x7)/Cube 0: Measurement grid: dx=8mm, dy=8mm, dz=5mm

Reference Value = 3.017 V/m; Power Drift = 0.154 dB

Peak SAR (extrapolated) = 0.248 W/kg

SAR(1 g) = 0.128 mW/g; SAR(10 g) = 0.065 mW/g

Maximum value of SAR (measured) = 0.139 mW/g

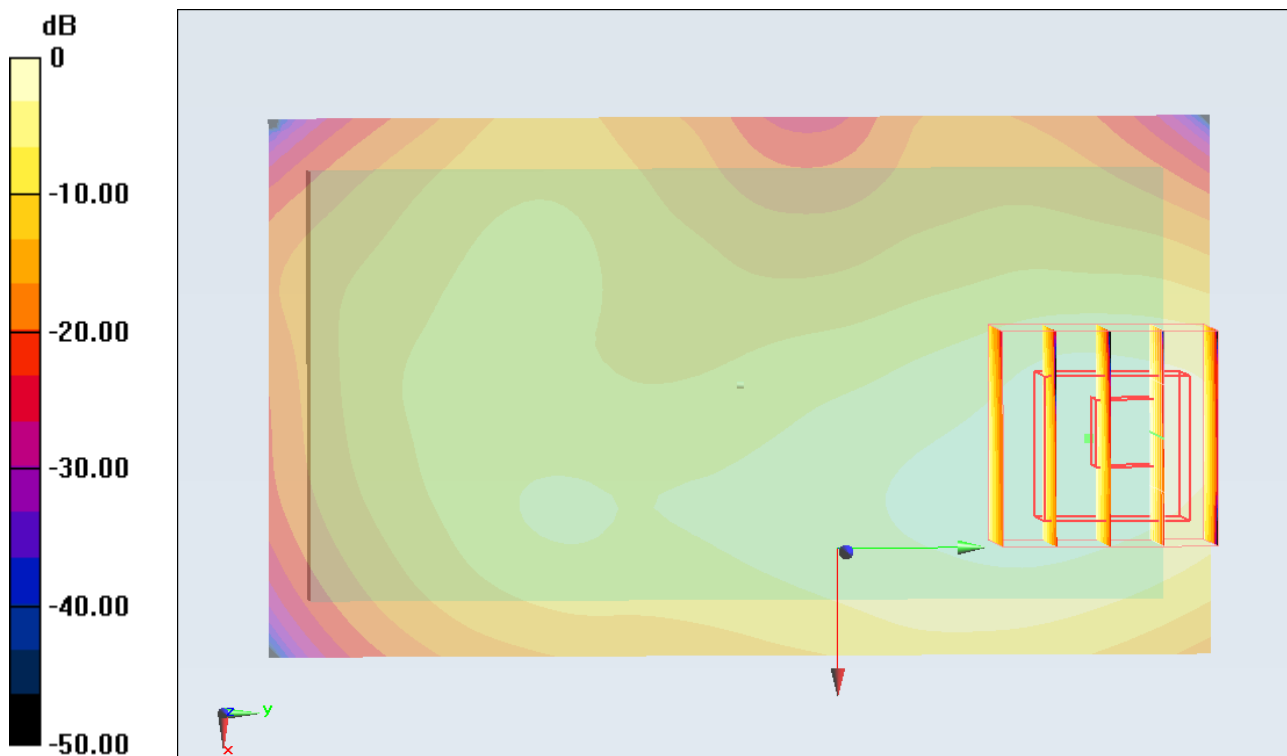

0 dB = 0.140mW/g

#39 802.11b_Back_1cm_Ch1_Earphone

DUT: 190327

Communication System: 802.11b; Frequency: 2412 MHz; Duty Cycle: 1:1

Medium: MSL_2450_110928 Medium parameters used: $f = 2412 \text{ MHz}$; $\sigma = 1.91 \text{ mho/m}$; $\epsilon_r = 54.765$;

$\rho = 1000 \text{ kg/m}^3$

Ambient Temperature : 22.5 °C ; Liquid Temperature : 21.5 °C

DASY5 Configuration:

- Probe: EX3DV4 - SN3792; ConvF(6.67, 6.67, 6.67); Calibrated: 2011/6/20
- Sensor-Surface: 4mm (Mechanical Surface Detection)
- Electronics: DAE4 Sn1279; Calibrated: 2011/6/17
- Phantom: SAM Right; Type: QD000P40CD; Serial: TP:1644
- Measurement SW: DASY52, Version 52.6 (2); SEMCAD X Version 14.4.5 (3634)

Ch1/Area Scan (61x101x1): Measurement grid: $dx=15\text{mm}$, $dy=15\text{mm}$

Maximum value of SAR (interpolated) = 0.114 mW/g

Ch1/Zoom Scan (5x5x7)/Cube 0: Measurement grid: $dx=8\text{mm}$, $dy=8\text{mm}$, $dz=5\text{mm}$

Reference Value = 2.783 V/m; Power Drift = 0.134 dB

Peak SAR (extrapolated) = 0.223 W/kg

SAR(1 g) = 0.116 mW/g; SAR(10 g) = 0.058 mW/g

Maximum value of SAR (measured) = 0.127 mW/g

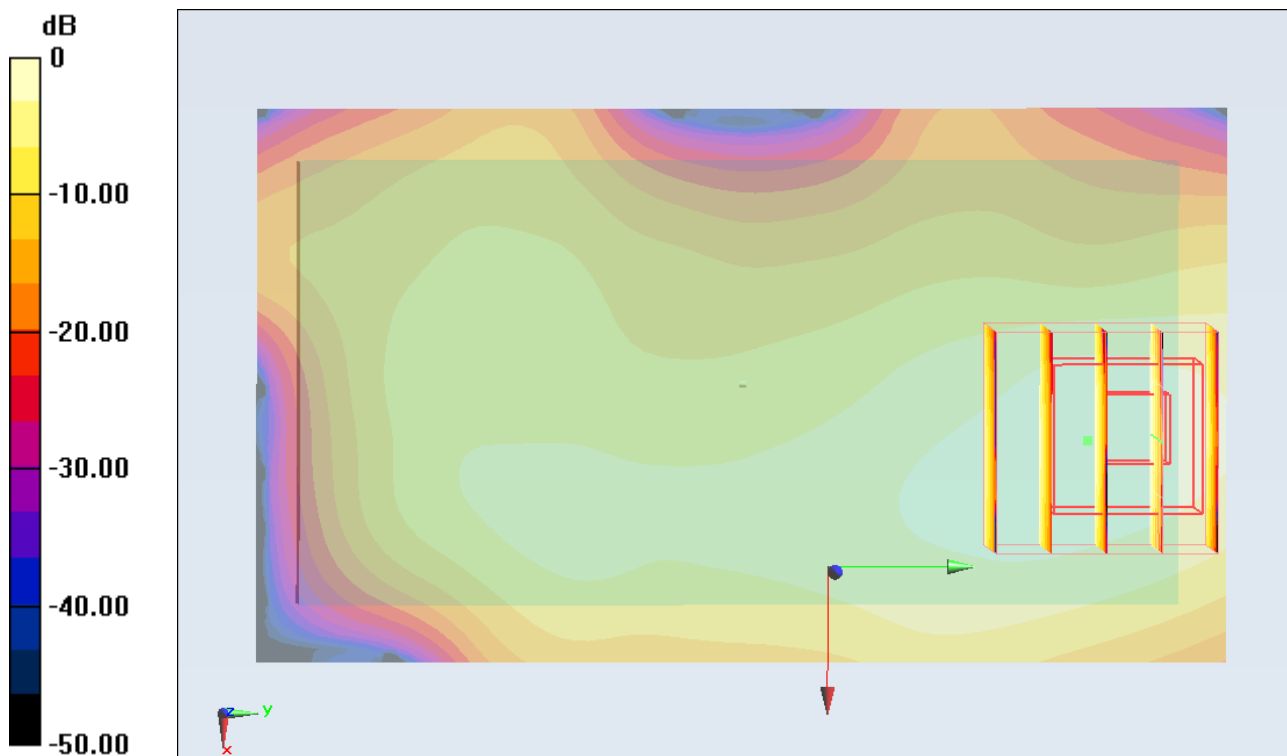

0 dB = 0.130mW/g