

#29 CDMA2000 BC0_RC3+SO55_Right Cheek_Ch777

DUT: 181934

Communication System: CDMA ; Frequency: 848.31 MHz;Duty Cycle: 1:1

Medium: HSL_850_111004 Medium parameters used : $f = 848.31$ MHz; $\sigma = 0.909$ mho/m; $\epsilon_r =$

41.493 ; $\rho = 1000$ kg/m³

Ambient Temperature : 22.3 °C ; Liquid Temperature : 21.3 °C

DASY5 Configuration:

- Probe: ES3DV3 - SN3270; ConvF(6.04, 6.04, 6.04); Calibrated: 2011/9/12
- Sensor-Surface: 4mm (Mechanical Surface Detection)
- Electronics: DAE3 Sn495; Calibrated: 2011/4/28
- Phantom: SAM Left; Type: QD000P40CD; Serial: TP:1542
- Measurement SW: DASY52, Version 52.6 (2); SEMCAD X Version 14.4.5 (3634)

Ch777/Area Scan (41x81x1): Measurement grid: dx=20mm, dy=20mm

Maximum value of SAR (interpolated) = 0.519 mW/g

Ch777/Zoom Scan (5x5x7)/Cube 0: Measurement grid: dx=8mm, dy=8mm, dz=5mm

Reference Value = 7.670 V/m; Power Drift = -0.11 dB

Peak SAR (extrapolated) = 0.683 W/kg

SAR(1 g) = 0.500 mW/g; SAR(10 g) = 0.361 mW/g

Maximum value of SAR (measured) = 0.524 mW/g

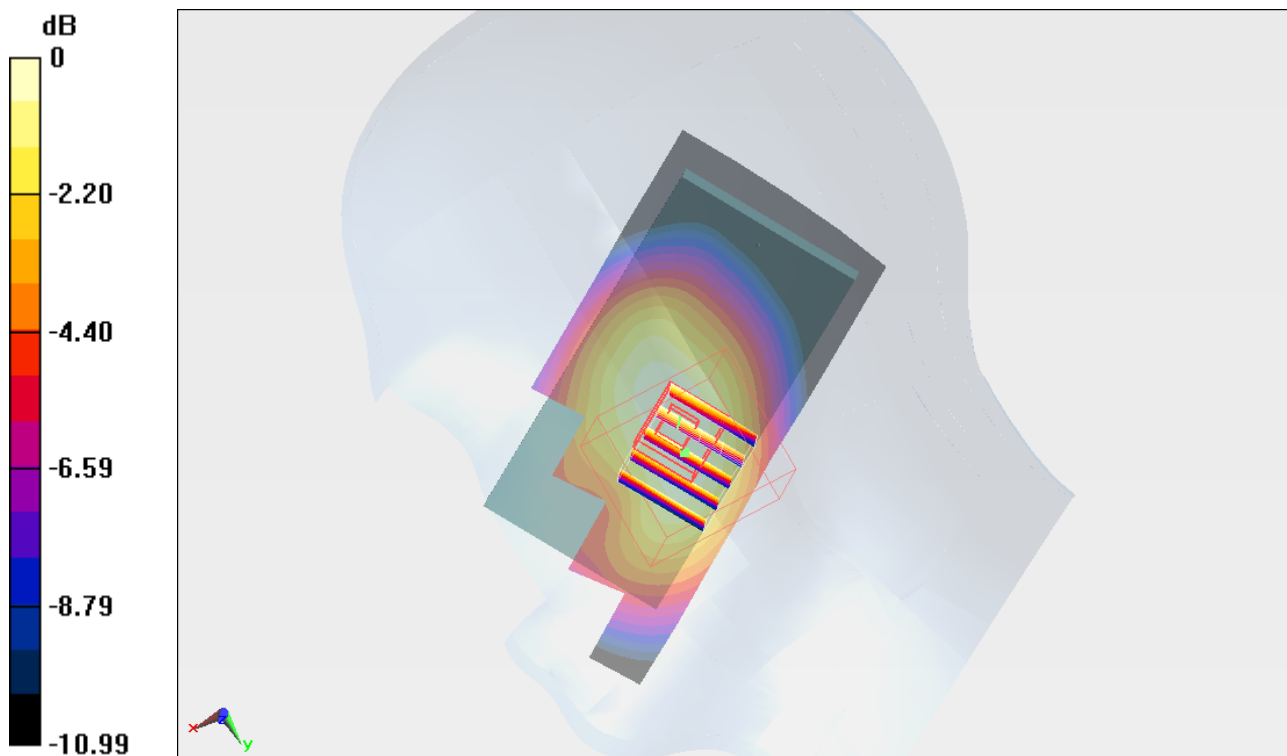

0 dB = 0.520mW/g

#30 CDMA2000 BC0_RC3+SO55_Right Tilted_Ch777

DUT: 181934

Communication System: CDMA ; Frequency: 848.31 MHz;Duty Cycle: 1:1

Medium: HSL_850_111004 Medium parameters used : $f = 848.31$ MHz; $\sigma = 0.909$ mho/m; $\epsilon_r =$

41.493 ; $\rho = 1000$ kg/m³

Ambient Temperature : 22.3 °C ; Liquid Temperature : 21.3 °C

DASY5 Configuration:

- Probe: ES3DV3 - SN3270; ConvF(6.04, 6.04, 6.04); Calibrated: 2011/9/12
- Sensor-Surface: 4mm (Mechanical Surface Detection)
- Electronics: DAE3 Sn495; Calibrated: 2011/4/28
- Phantom: SAM Left; Type: QD000P40CD; Serial: TP:1542
- Measurement SW: DASY52, Version 52.6 (2); SEMCAD X Version 14.4.5 (3634)

Ch777/Area Scan (41x81x1): Measurement grid: dx=20mm, dy=20mm

Maximum value of SAR (interpolated) = 0.370 mW/g

Ch777/Zoom Scan (5x5x7)/Cube 0: Measurement grid: dx=8mm, dy=8mm, dz=5mm

Reference Value = 13.297 V/m; Power Drift = -0.09 dB

Peak SAR (extrapolated) = 0.434 W/kg

SAR(1 g) = 0.350 mW/g; SAR(10 g) = 0.268 mW/g

Maximum value of SAR (measured) = 0.367 mW/g

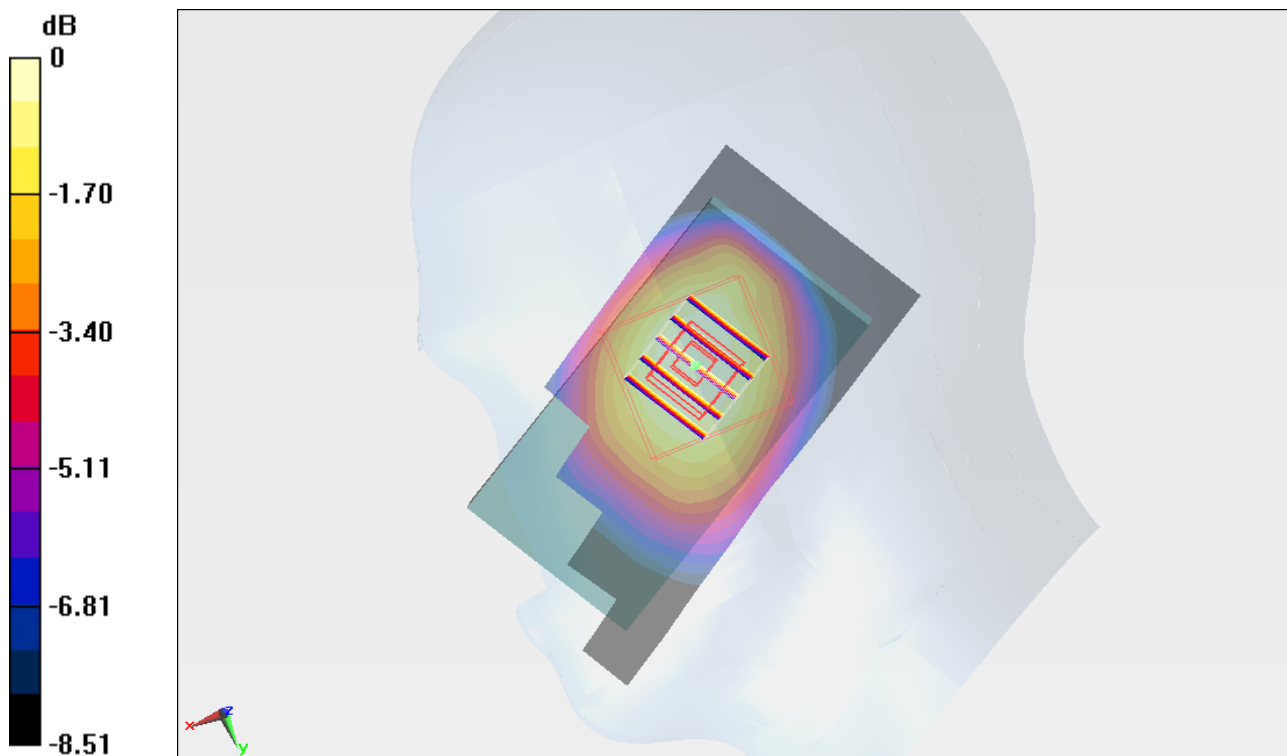

0 dB = 0.370mW/g

#31 CDMA2000 BC0_RC3+SO55_Left Cheek_Ch777

DUT: 181934

Communication System: CDMA ; Frequency: 848.31 MHz;Duty Cycle: 1:1

Medium: HSL_850_111004 Medium parameters used : $f = 848.31$ MHz; $\sigma = 0.909$ mho/m; $\epsilon_r =$

41.493 ; $\rho = 1000$ kg/m³

Ambient Temperature : 22.3 °C ; Liquid Temperature : 21.3 °C

DASY5 Configuration:

- Probe: ES3DV3 - SN3270; ConvF(6.04, 6.04, 6.04); Calibrated: 2011/9/12
- Sensor-Surface: 4mm (Mechanical Surface Detection)
- Electronics: DAE3 Sn495; Calibrated: 2011/4/28
- Phantom: SAM Left; Type: QD000P40CD; Serial: TP:1542
- Measurement SW: DASY52, Version 52.6 (2); SEMCAD X Version 14.4.5 (3634)

Ch777/Area Scan (41x81x1): Measurement grid: dx=20mm, dy=20mm

Maximum value of SAR (interpolated) = 0.602 mW/g

Ch777/Zoom Scan (5x5x7)/Cube 0: Measurement grid: dx=8mm, dy=8mm, dz=5mm

Reference Value = 7.196 V/m; Power Drift = 0.02 dB

Peak SAR (extrapolated) = 0.707 W/kg

SAR(1 g) = 0.571 mW/g; SAR(10 g) = 0.432 mW/g

Maximum value of SAR (measured) = 0.600 mW/g

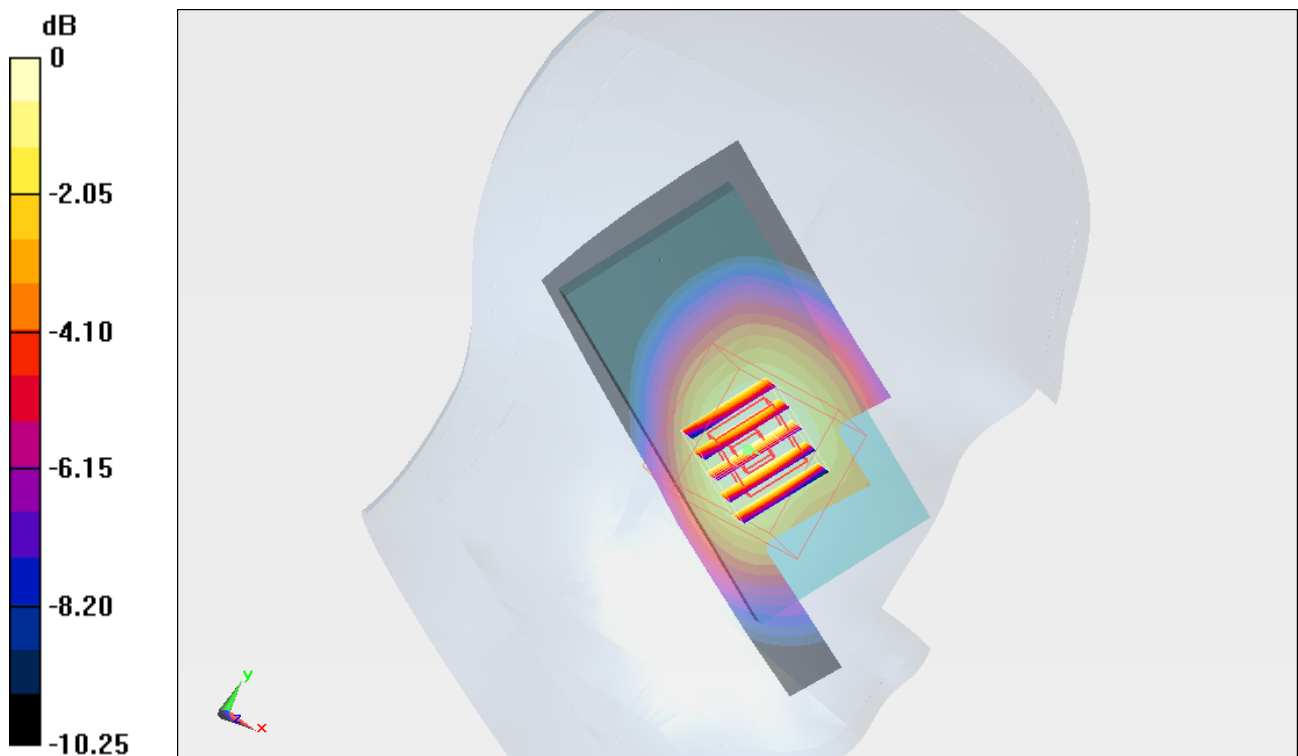

0 dB = 0.600mW/g

#31 CDMA2000 BC0_RC3+SO55_Left Cheek_Ch777_2D

DUT: 181934

Communication System: CDMA ; Frequency: 848.31 MHz; Duty Cycle: 1:1

Medium: HSL_850_111004 Medium parameters used : $f = 848.31 \text{ MHz}$; $\sigma = 0.909 \text{ mho/m}$; $\epsilon_r =$

41.493 ; $\rho = 1000 \text{ kg/m}^3$

Ambient Temperature : $22.3 \text{ }^\circ\text{C}$; Liquid Temperature : $21.3 \text{ }^\circ\text{C}$

DASY5 Configuration:

- Probe: ES3DV3 - SN3270; ConvF(6.04, 6.04, 6.04); Calibrated: 2011/9/12
- Sensor-Surface: 4mm (Mechanical Surface Detection)
- Electronics: DAE3 Sn495; Calibrated: 2011/4/28
- Phantom: SAM Left; Type: QD000P40CD; Serial: TP:1542
- Measurement SW: DASY52, Version 52.6 (2); SEMCAD X Version 14.4.5 (3634)

Ch777/Area Scan (41x81x1): Measurement grid: $dx=20\text{mm}$, $dy=20\text{mm}$

Maximum value of SAR (interpolated) = 0.602 mW/g

Ch777/Zoom Scan (5x5x7)/Cube 0: Measurement grid: $dx=8\text{mm}$, $dy=8\text{mm}$, $dz=5\text{mm}$

Reference Value = 7.196 V/m ; Power Drift = 0.02 dB

Peak SAR (extrapolated) = 0.707 W/kg

SAR(1 g) = 0.571 mW/g ; SAR(10 g) = 0.432 mW/g

Maximum value of SAR (measured) = 0.600 mW/g

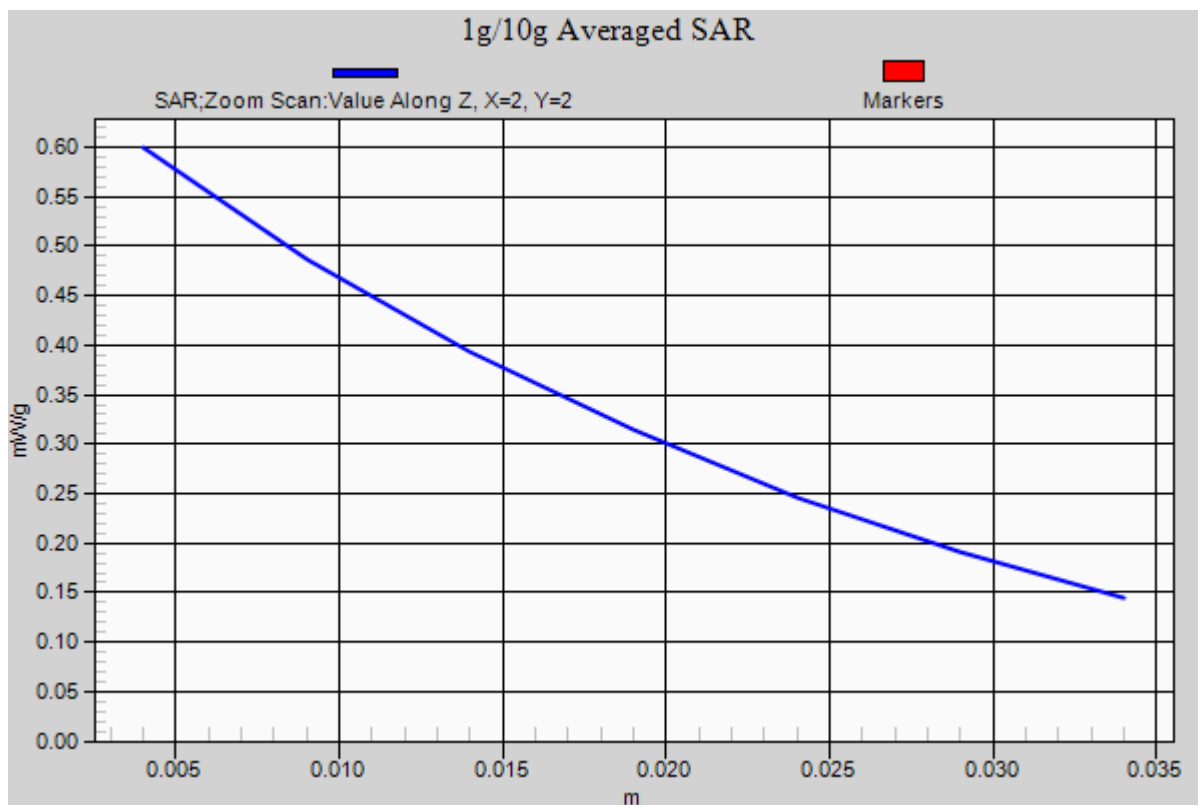

#32 CDMA2000 BC0_RC3+SO55_Left Tilted_Ch777

DUT: 181934

Communication System: CDMA ; Frequency: 848.31 MHz;Duty Cycle: 1:1

Medium: HSL_850_111004 Medium parameters used : $f = 848.31$ MHz; $\sigma = 0.909$ mho/m; $\epsilon_r =$

41.493 ; $\rho = 1000$ kg/m³

Ambient Temperature : 22.3 °C ; Liquid Temperature : 21.3 °C

DASY5 Configuration:

- Probe: ES3DV3 - SN3270; ConvF(6.04, 6.04, 6.04); Calibrated: 2011/9/12
- Sensor-Surface: 4mm (Mechanical Surface Detection)
- Electronics: DAE3 Sn495; Calibrated: 2011/4/28
- Phantom: SAM Left; Type: QD000P40CD; Serial: TP:1542
- Measurement SW: DASY52, Version 52.6 (2); SEMCAD X Version 14.4.5 (3634)

Ch777/Area Scan (41x81x1): Measurement grid: dx=20mm, dy=20mm

Maximum value of SAR (interpolated) = 0.323 mW/g

Ch777/Zoom Scan (5x5x7)/Cube 0: Measurement grid: dx=8mm, dy=8mm, dz=5mm

Reference Value = 11.998 V/m; Power Drift = -0.04 dB

Peak SAR (extrapolated) = 0.384 W/kg

SAR(1 g) = 0.304 mW/g; SAR(10 g) = 0.231 mW/g

Maximum value of SAR (measured) = 0.320 mW/g

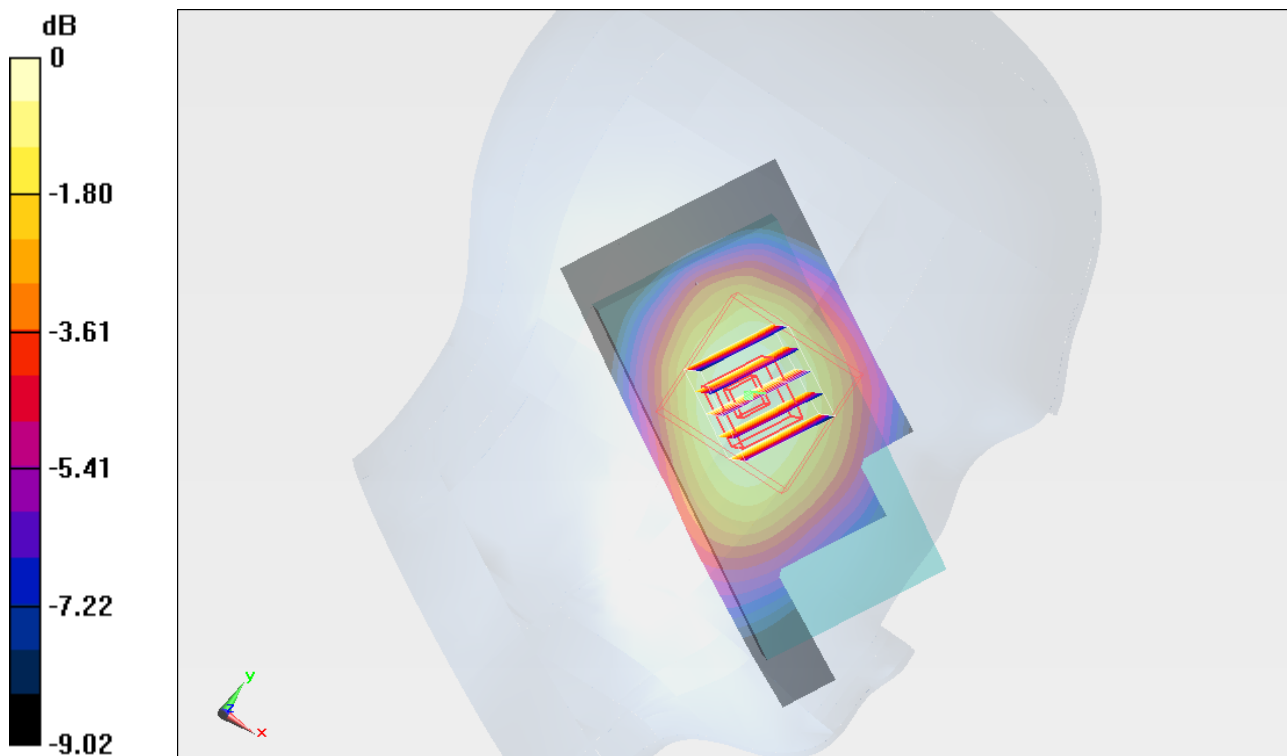

0 dB = 0.320mW/g

#25 GSM1900_Right Cheek_Ch512

DUT: 181934

Communication System: PCS; Frequency: 1850.2 MHz; Duty Cycle: 1:8.3

Medium: HSL_1900_111004 Medium parameters used: $f = 1850.2$ MHz; $\sigma = 1.39$ mho/m; $\epsilon_r = 38.3$; $\rho = 1000$ kg/m³

Ambient Temperature : 22.4 °C; Liquid Temperature : 21.4 °C

DASY4 Configuration:

- Probe: EX3DV4 - SN3697; ConvF(7.46, 7.46, 7.46); Calibrated: 2011-09-02
- Sensor-Surface: 4mm (Mechanical Surface Detection)
- Electronics: DAE4 Sn905; Calibrated: 2011-06-24
- Phantom: SAM_Left; Type: SAM; Serial: TP-1150
- Measurement SW: DASY4, V4.7 Build 80; Postprocessing SW: SEMCAD, V1.8 Build 186

Ch512/Area Scan (41x81x1): Measurement grid: dx=20mm, dy=20mm

Maximum value of SAR (interpolated) = 0.203 mW/g

Ch512/Zoom Scan (5x5x7)/Cube 0: Measurement grid: dx=8mm, dy=8mm, dz=5mm

Reference Value = 2.75 V/m; Power Drift = 0.015 dB

Peak SAR (extrapolated) = 0.287 W/kg

SAR(1 g) = 0.177 mW/g; SAR(10 g) = 0.106 mW/g

Maximum value of SAR (measured) = 0.190 mW/g

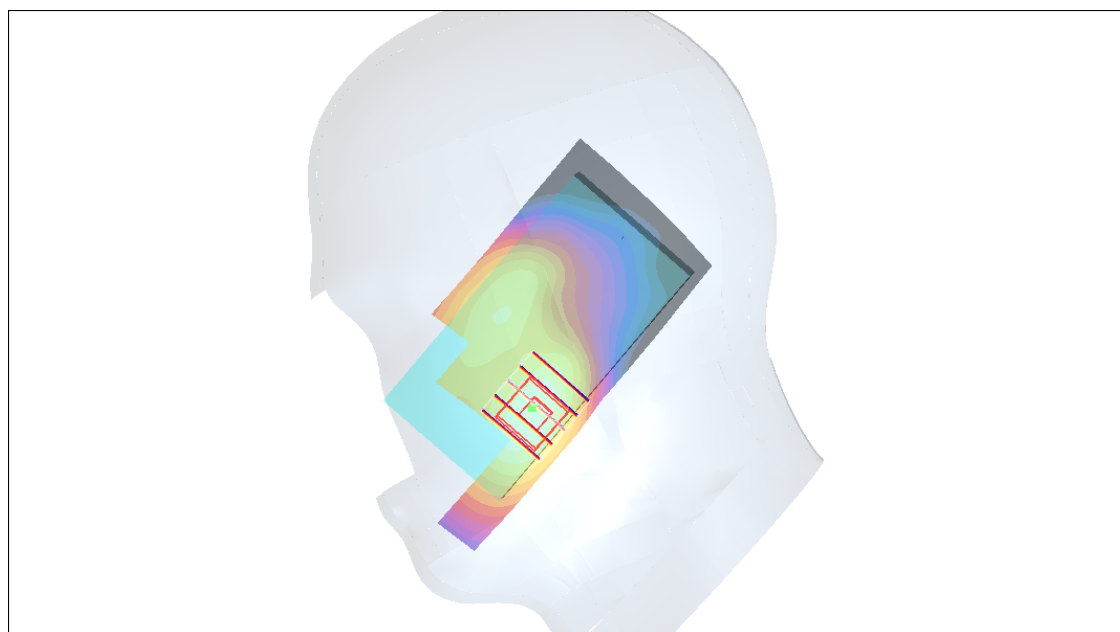
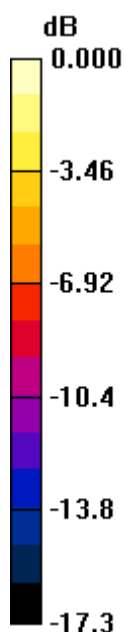

0 dB = 0.190mW/g

#25 GSM1900_Right Cheek_Ch512_2D

DUT: 181934

Communication System: PCS; Frequency: 1850.2 MHz; Duty Cycle: 1:8.3

Medium: HSL_1900_111004 Medium parameters used: $f = 1850.2$ MHz; $\sigma = 1.39$ mho/m; $\epsilon_r = 38.3$; $\rho = 1000$ kg/m³

Ambient Temperature : 22.4 °C ; Liquid Temperature : 21.4 °C

DASY4 Configuration:

- Probe: EX3DV4 - SN3697; ConvF(7.46, 7.46, 7.46); Calibrated: 2011-09-02
- Sensor-Surface: 4mm (Mechanical Surface Detection)
- Electronics: DAE4 Sn905; Calibrated: 2011-06-24
- Phantom: SAM_Left; Type: SAM; Serial: TP-1150
- Measurement SW: DASY4, V4.7 Build 80; Postprocessing SW: SEMCAD, V1.8 Build 186

Ch512/Area Scan (41x81x1): Measurement grid: dx=20mm, dy=20mm

Maximum value of SAR (interpolated) = 0.203 mW/g

Ch512/Zoom Scan (5x5x7)/Cube 0: Measurement grid: dx=8mm, dy=8mm, dz=5mm

Reference Value = 2.75 V/m; Power Drift = 0.015 dB

Peak SAR (extrapolated) = 0.287 W/kg

SAR(1 g) = 0.177 mW/g; SAR(10 g) = 0.106 mW/g

Maximum value of SAR (measured) = 0.190 mW/g

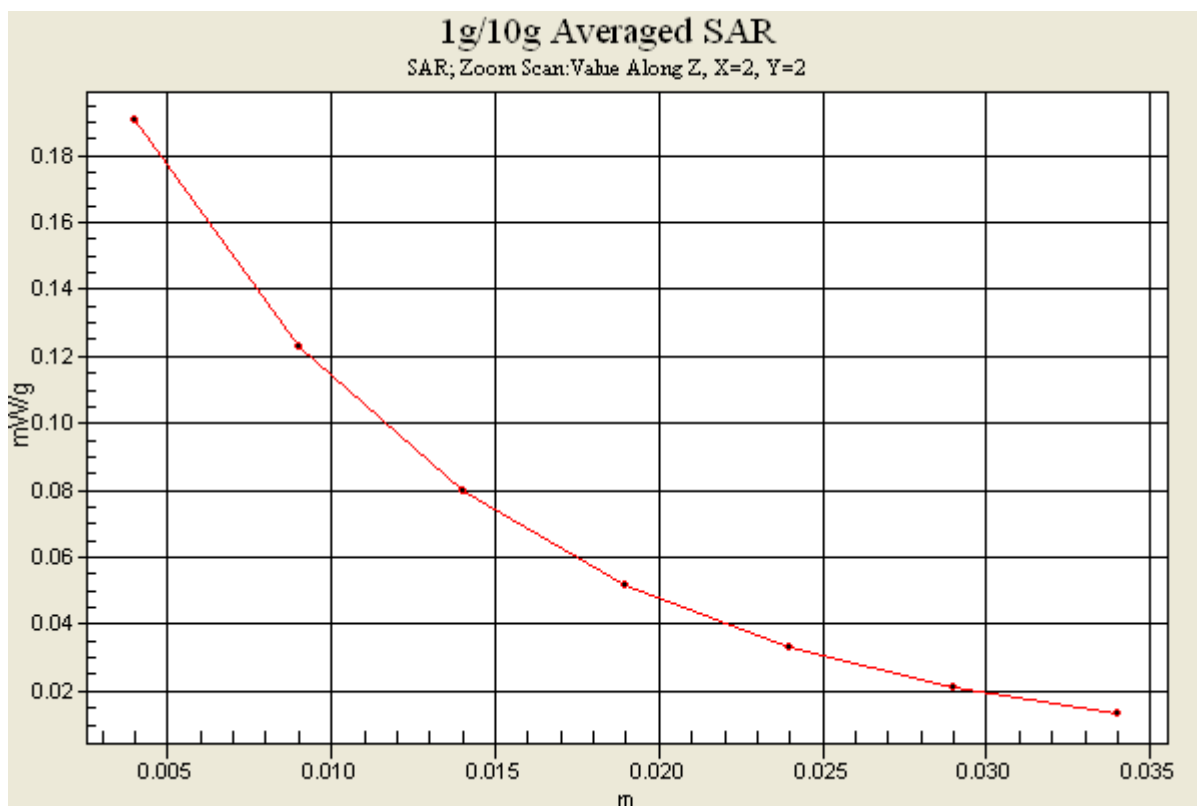

#26 GSM1900_Right Tilted_Ch512

DUT: 181934

Communication System: PCS; Frequency: 1850.2 MHz; Duty Cycle: 1:8.3

Medium: HSL_1900_111004 Medium parameters used: $f = 1850.2 \text{ MHz}$; $\sigma = 1.39 \text{ mho/m}$; $\epsilon_r = 38.3$; $\rho = 1000 \text{ kg/m}^3$

Ambient Temperature : 22.4 °C ; Liquid Temperature : 21.4 °C

DASY4 Configuration:

- Probe: EX3DV4 - SN3697; ConvF(7.46, 7.46, 7.46); Calibrated: 2011-09-02
- Sensor-Surface: 4mm (Mechanical Surface Detection)
- Electronics: DAE4 Sn905; Calibrated: 2011-06-24
- Phantom: SAM_Left; Type: SAM; Serial: TP-1150
- Measurement SW: DASY4, V4.7 Build 80; Postprocessing SW: SEMCAD, V1.8 Build 186

Ch512/Area Scan (41x81x1): Measurement grid: dx=20mm, dy=20mm

Maximum value of SAR (interpolated) = 0.063 mW/g

Ch512/Zoom Scan (5x5x7)/Cube 0: Measurement grid: dx=8mm, dy=8mm, dz=5mm

Reference Value = 4.41 V/m; Power Drift = -0.088 dB

Peak SAR (extrapolated) = 0.078 W/kg

SAR(1 g) = 0.050 mW/g; SAR(10 g) = 0.031 mW/g

Maximum value of SAR (measured) = 0.053 mW/g

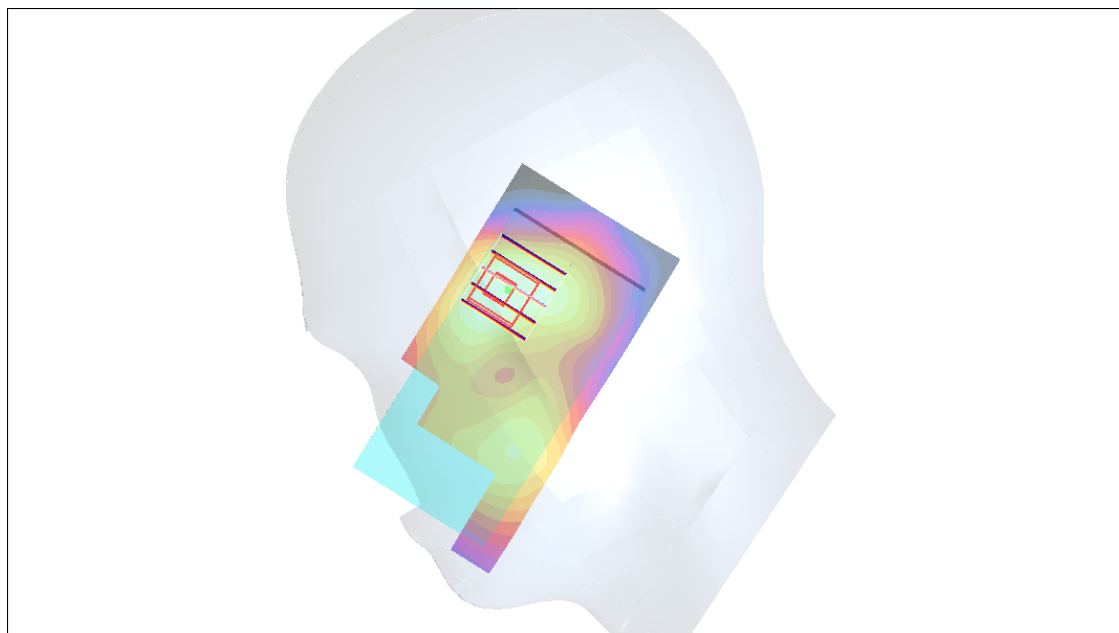
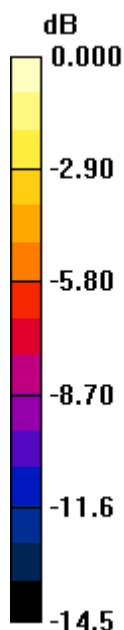

0 dB = 0.053mW/g

#27 GSM1900_Left Cheek_Ch512

DUT: 181934

Communication System: PCS; Frequency: 1850.2 MHz; Duty Cycle: 1:8.3

Medium: HSL_1900_111004 Medium parameters used: $f = 1850.2 \text{ MHz}$; $\sigma = 1.39 \text{ mho/m}$; $\epsilon_r = 38.3$; $\rho = 1000 \text{ kg/m}^3$

Ambient Temperature : 22.4 °C; Liquid Temperature : 21.4 °C

DASY4 Configuration:

- Probe: EX3DV4 - SN3697; ConvF(7.46, 7.46, 7.46); Calibrated: 2011-09-02
- Sensor-Surface: 4mm (Mechanical Surface Detection)
- Electronics: DAE4 Sn905; Calibrated: 2011-06-24
- Phantom: SAM_Left; Type: SAM; Serial: TP-1150
- Measurement SW: DASY4, V4.7 Build 80; Postprocessing SW: SEMCAD, V1.8 Build 186

Ch512/Area Scan (41x81x1): Measurement grid: $dx=20\text{mm}$, $dy=20\text{mm}$

Maximum value of SAR (interpolated) = 0.170 mW/g

Ch512/Zoom Scan (5x5x7)/Cube 0: Measurement grid: $dx=8\text{mm}$, $dy=8\text{mm}$, $dz=5\text{mm}$

Reference Value = 3.25 V/m; Power Drift = 0.122 dB

Peak SAR (extrapolated) = 0.250 W/kg

SAR(1 g) = 0.157 mW/g; SAR(10 g) = 0.092 mW/g

Maximum value of SAR (measured) = 0.163 mW/g

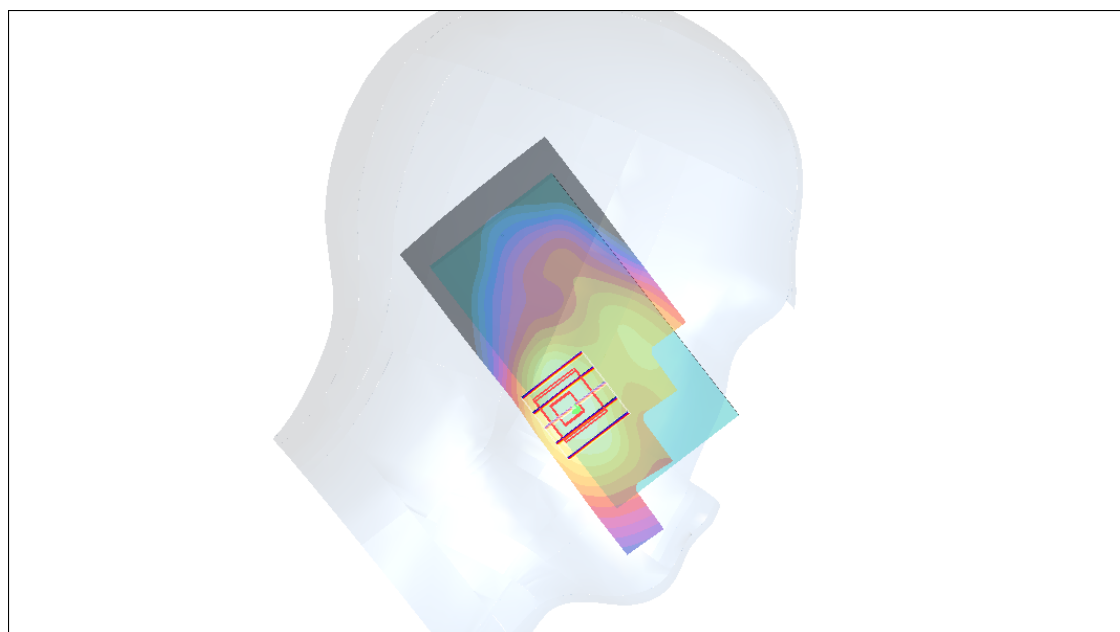
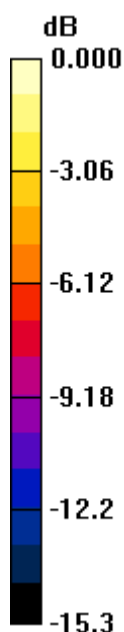

0 dB = 0.163mW/g

#28 GSM1900_Left Tilted_Ch512

DUT: 181934

Communication System: PCS; Frequency: 1850.2 MHz; Duty Cycle: 1:8.3

Medium: HSL_1900_111004 Medium parameters used: $f = 1850.2$ MHz; $\sigma = 1.39$ mho/m; $\epsilon_r = 38.3$; $\rho = 1000$ kg/m³

Ambient Temperature : 22.4 °C ; Liquid Temperature : 21.4 °C

DASY4 Configuration:

- Probe: EX3DV4 - SN3697; ConvF(7.46, 7.46, 7.46); Calibrated: 2011-09-02
- Sensor-Surface: 4mm (Mechanical Surface Detection)
- Electronics: DAE4 Sn905; Calibrated: 2011-06-24
- Phantom: SAM_Left; Type: SAM; Serial: TP-1150
- Measurement SW: DASY4, V4.7 Build 80; Postprocessing SW: SEMCAD, V1.8 Build 186

Ch512/Area Scan (41x81x1): Measurement grid: dx=20mm, dy=20mm

Maximum value of SAR (interpolated) = 0.039 mW/g

Ch512/Zoom Scan (5x5x7)/Cube 0: Measurement grid: dx=8mm, dy=8mm, dz=5mm

Reference Value = 4.85 V/m; Power Drift = -0.103 dB

Peak SAR (extrapolated) = 0.061 W/kg

SAR(1 g) = 0.037 mW/g; SAR(10 g) = 0.022 mW/g

Maximum value of SAR (measured) = 0.041 mW/g

Ch512/Zoom Scan (5x5x7)/Cube 1: Measurement grid: dx=8mm, dy=8mm, dz=5mm

Reference Value = 4.85 V/m; Power Drift = -0.103 dB

Peak SAR (extrapolated) = 0.038 W/kg

SAR(1 g) = 0.023 mW/g; SAR(10 g) = 0.015 mW/g

Maximum value of SAR (measured) = 0.025 mW/g

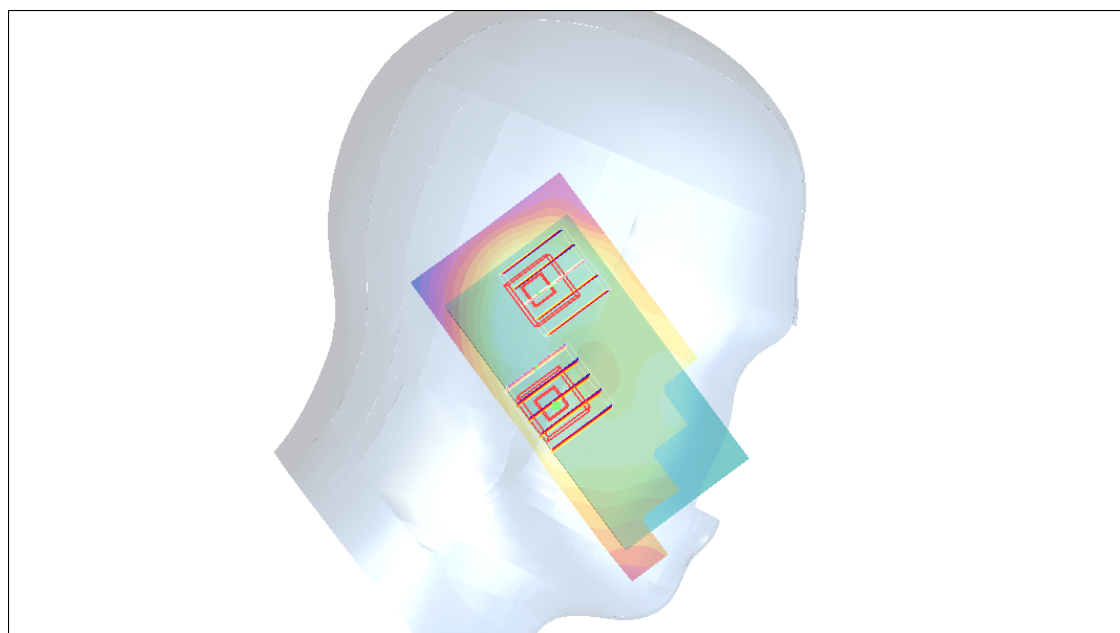
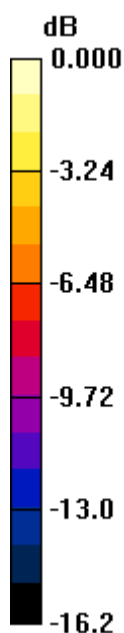

0 dB = 0.025mW/g

#01 802.11b_Right Cheek_Ch6

DUT: 181934

Communication System: 802.11b ; Frequency: 2437 MHz;Duty Cycle: 1:1

Medium: HSL_2450_110916 Medium parameters used: $f = 2437$ MHz; $\sigma = 1.82$ mho/m; $\epsilon_r = 39.6$; $\rho = 1000$ kg/m³

Ambient Temperature : 22.6 °C ; Liquid Temperature : 21.6 °C

DASY4 Configuration:

- Probe: EX3DV4 - SN3697; ConvF(6.67, 6.67, 6.67); Calibrated: 2011/9/2
- Sensor-Surface: 4mm (Mechanical Surface Detection)
- Electronics: DAE4 Sn1279; Calibrated: 2011/6/17
- Phantom: SAM-Right; Type: QD 000 P40 C; Serial: TP-1383
- Measurement SW: DASY4, V4.7 Build 80; Postprocessing SW: SEMCAD, V1.8 Build 186

Ch6/Area Scan (51x81x1): Measurement grid: dx=20mm, dy=20mm

Maximum value of SAR (interpolated) = 0.122 mW/g

Ch6/Zoom Scan (5x5x7)/Cube 0: Measurement grid: dx=8mm, dy=8mm, dz=5mm

Reference Value = 4.69 V/m; Power Drift = -0.178 dB

Peak SAR (extrapolated) = 0.209 W/kg

SAR(1 g) = 0.099 mW/g; SAR(10 g) = 0.050 mW/g

Maximum value of SAR (measured) = 0.105 mW/g

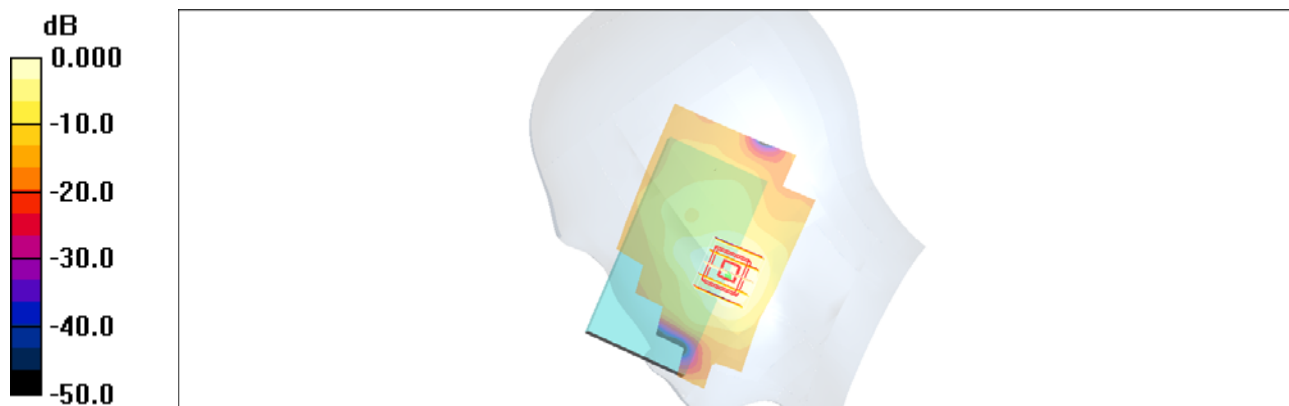

0 dB = 0.105mW/g

#01 802.11b_Right Cheek_Ch6_2D

DUT: 181934

Communication System: 802.11b ; Frequency: 2437 MHz;Duty Cycle: 1:1

Medium: HSL_2450_110916 Medium parameters used: $f = 2437$ MHz; $\sigma = 1.82$ mho/m; $\epsilon_r = 39.6$; $\rho = 1000$ kg/m³

Ambient Temperature : 22.6 °C ; Liquid Temperature : 21.6 °C

DASY4 Configuration:

- Probe: EX3DV4 - SN3697; ConvF(6.67, 6.67, 6.67); Calibrated: 2011/9/2
- Sensor-Surface: 4mm (Mechanical Surface Detection)
- Electronics: DAE4 Sn1279; Calibrated: 2011/6/17
- Phantom: SAM-Right; Type: QD 000 P40 C; Serial: TP-1383
- Measurement SW: DASY4, V4.7 Build 80; Postprocessing SW: SEMCAD, V1.8 Build 186

Ch6/Area Scan (51x81x1): Measurement grid: dx=20mm, dy=20mm

Maximum value of SAR (interpolated) = 0.122 mW/g

Ch6/Zoom Scan (5x5x7)/Cube 0: Measurement grid: dx=8mm, dy=8mm, dz=5mm

Reference Value = 4.69 V/m; Power Drift = -0.178 dB

Peak SAR (extrapolated) = 0.209 W/kg

SAR(1 g) = 0.099 mW/g; SAR(10 g) = 0.050 mW/g

Maximum value of SAR (measured) = 0.105 mW/g

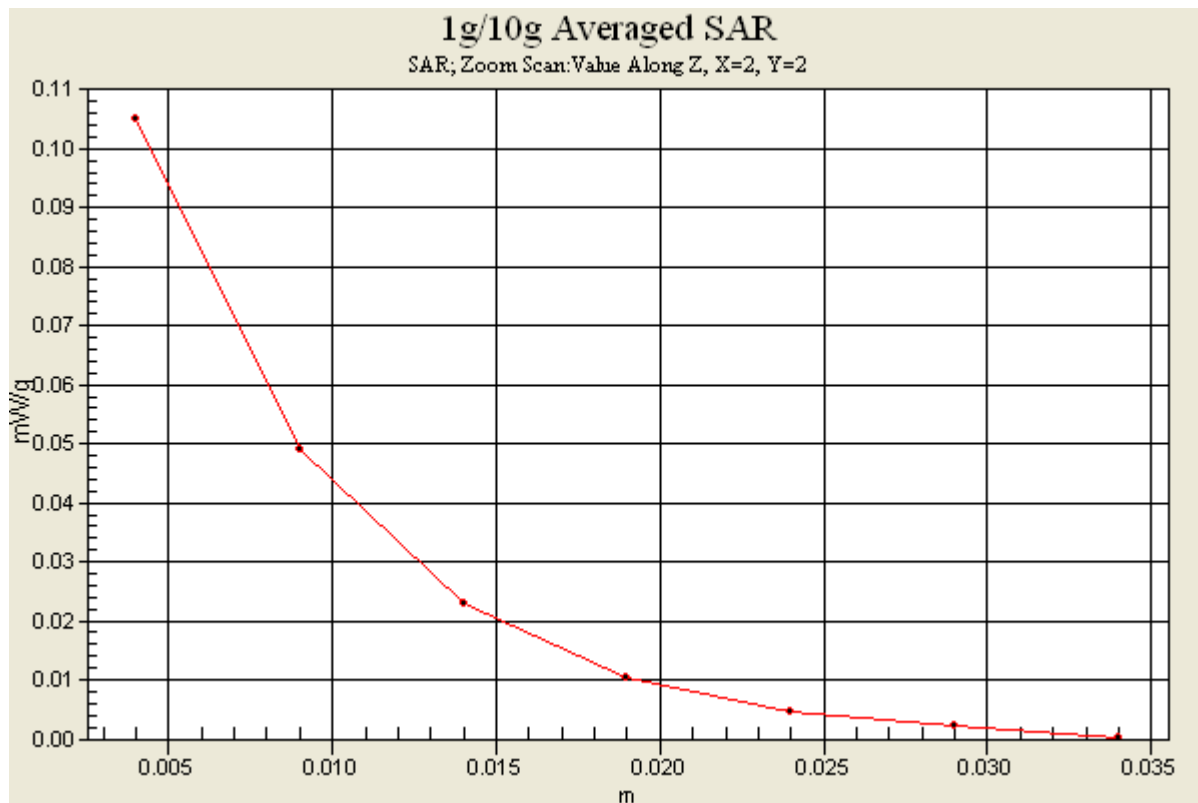

#02 802.11b_Right Tilted_Ch6

DUT: 181934

Communication System: 802.11b ; Frequency: 2437 MHz;Duty Cycle: 1:1

Medium: HSL_2450_110916 Medium parameters used: $f = 2437$ MHz; $\sigma = 1.82$ mho/m; $\epsilon_r = 39.6$; $\rho = 1000$ kg/m³

Ambient Temperature : 22.6 °C ; Liquid Temperature : 21.6 °C

DASY4 Configuration:

- Probe: EX3DV4 - SN3697; ConvF(6.67, 6.67, 6.67); Calibrated: 2011/9/2
- Sensor-Surface: 4mm (Mechanical Surface Detection)
- Electronics: DAE4 Sn1279; Calibrated: 2011/6/17
- Phantom: SAM-Right; Type: QD 000 P40 C; Serial: TP-1383
- Measurement SW: DASY4, V4.7 Build 80; Postprocessing SW: SEMCAD, V1.8 Build 186

Ch6/Area Scan (41x81x1): Measurement grid: dx=20mm, dy=20mm

Maximum value of SAR (interpolated) = 0.012 mW/g

Ch6/Zoom Scan (5x5x7)/Cube 0: Measurement grid: dx=8mm, dy=8mm, dz=5mm

Reference Value = 2.76 V/m; Power Drift = 0.026 dB

Peak SAR (extrapolated) = 0.033 W/kg

SAR(1 g) = 0.015 mW/g; SAR(10 g) = 0.00602 mW/g

Maximum value of SAR (measured) = 0.016 mW/g

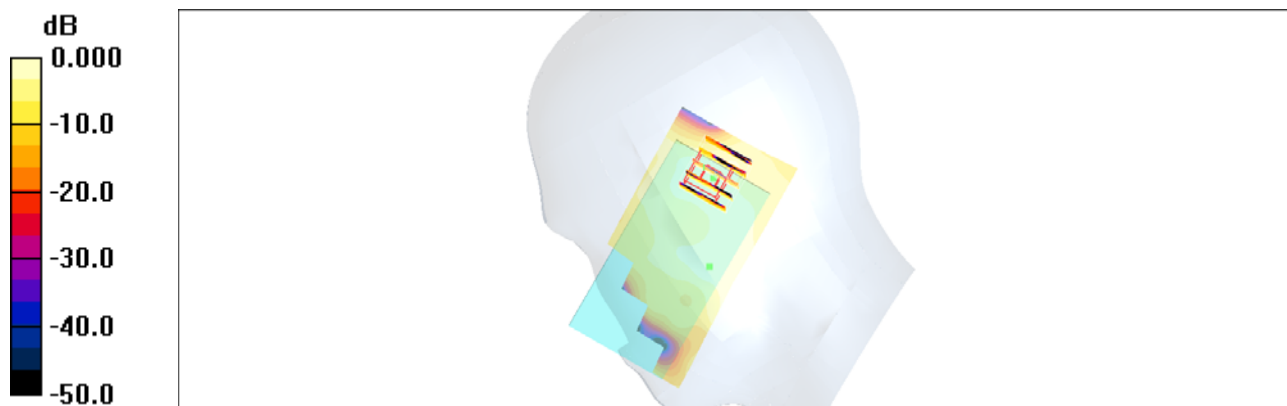

0 dB = 0.016mW/g

#03 802.11b_Left Cheek_Ch6

DUT: 181934

Communication System: 802.11b ; Frequency: 2437 MHz;Duty Cycle: 1:1

Medium: HSL_2450_110916 Medium parameters used: $f = 2437$ MHz; $\sigma = 1.82$ mho/m; $\epsilon_r = 39.6$; $\rho = 1000$ kg/m³

Ambient Temperature : 22.6 °C ; Liquid Temperature : 21.6 °C

DASY4 Configuration:

- Probe: EX3DV4 - SN3697; ConvF(6.67, 6.67, 6.67); Calibrated: 2011/9/2
- Sensor-Surface: 4mm (Mechanical Surface Detection)
- Electronics: DAE4 Sn1279; Calibrated: 2011/6/17
- Phantom: SAM-Right; Type: QD 000 P40 C; Serial: TP-1383
- Measurement SW: DASY4, V4.7 Build 80; Postprocessing SW: SEMCAD, V1.8 Build 186

Ch6/Area Scan (41x81x1): Measurement grid: dx=20mm, dy=20mm

Maximum value of SAR (interpolated) = 0.086 mW/g

Ch6/Zoom Scan (5x5x7)/Cube 0: Measurement grid: dx=8mm, dy=8mm, dz=5mm

Reference Value = 2.85 V/m; Power Drift = -0.152 dB

Peak SAR (extrapolated) = 0.192 W/kg

SAR(1 g) = 0.085 mW/g; SAR(10 g) = 0.040 mW/g

Maximum value of SAR (measured) = 0.087 mW/g

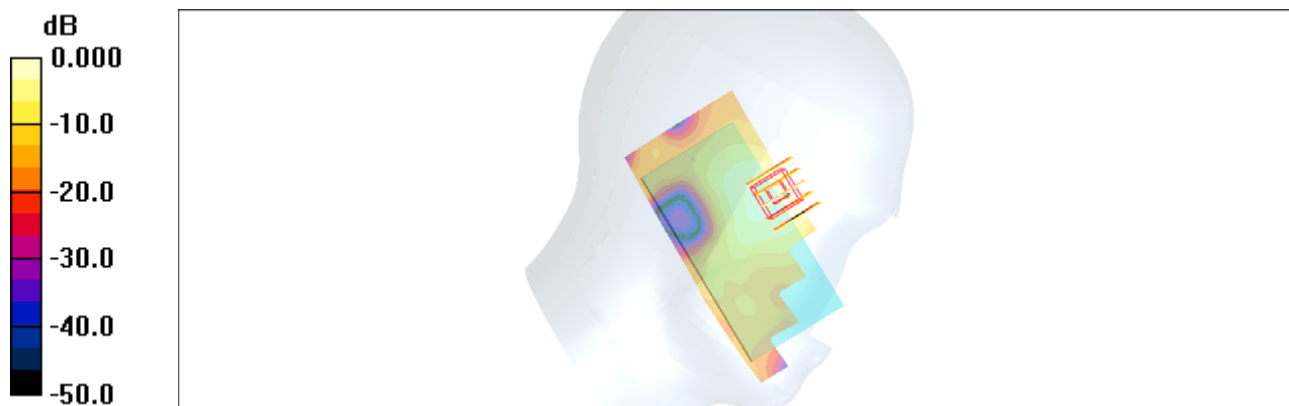

0 dB = 0.087mW/g

#04 802.11b_Left Tilted_Ch6

DUT: 181934

Communication System: 802.11b ; Frequency: 2437 MHz;Duty Cycle: 1:1

Medium: HSL_2450_110916 Medium parameters used: $f = 2437$ MHz; $\sigma = 1.82$ mho/m; $\epsilon_r = 39.6$; $\rho = 1000$ kg/m³

Ambient Temperature : 22.6 °C ; Liquid Temperature : 21.6 °C

DASY4 Configuration:

- Probe: EX3DV4 - SN3697; ConvF(6.67, 6.67, 6.67); Calibrated: 2011/9/2
- Sensor-Surface: 4mm (Mechanical Surface Detection)
- Electronics: DAE4 Sn1279; Calibrated: 2011/6/17
- Phantom: SAM-Right; Type: QD 000 P40 C; Serial: TP-1383
- Measurement SW: DASY4, V4.7 Build 80; Postprocessing SW: SEMCAD, V1.8 Build 186

Ch6/Area Scan (41x81x1): Measurement grid: dx=20mm, dy=20mm

Maximum value of SAR (interpolated) = 0.068 mW/g

Ch6/Zoom Scan (5x5x7)/Cube 0: Measurement grid: dx=8mm, dy=8mm, dz=5mm

Reference Value = 2.43 V/m; Power Drift = -0.179 dB

Peak SAR (extrapolated) = 0.019 W/kg

SAR(1 g) = 0.00612 mW/g; SAR(10 g) = 0.00232 mW/g

Maximum value of SAR (measured) = 0.006 mW/g

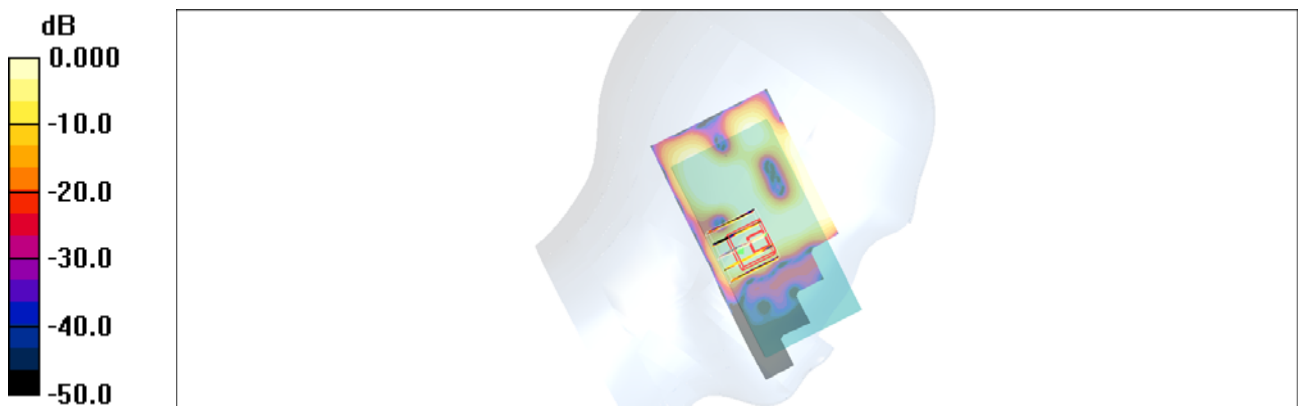

0 dB = 0.006mW/g

#33 CDMA2000 BC0_RC3+SO32_Front_1cm_Ch777

DUT: 181934

Communication System: CDMA ; Frequency: 848.31 MHz; Duty Cycle: 1:1

Medium: MSL_850_111004 Medium parameters used : $f = 848.31$ MHz; $\sigma = 0.968$ mho/m; $\epsilon_r =$

52.555 ; $\rho = 1000$ kg/m³

Ambient Temperature : 22.5 °C ; Liquid Temperature : 21.5 °C

DASY5 Configuration:

- Probe: ES3DV3 - SN3270; ConvF(6.16, 6.16, 6.16); Calibrated: 2011/9/12
- Sensor-Surface: 4mm (Mechanical Surface Detection)
- Electronics: DAE3 Sn495; Calibrated: 2011/4/28
- Phantom: SAM Right; Type: QD000P40CD; Serial: TP:1644
- Measurement SW: DASY52, Version 52.6 (2); SEMCAD X Version 14.4.5 (3634)

Ch777/Area Scan (51x81x1): Measurement grid: dx=20mm, dy=20mm

Maximum value of SAR (interpolated) = 0.806 mW/g

Ch777/Zoom Scan (5x5x7)/Cube 0: Measurement grid: dx=8mm, dy=8mm, dz=5mm

Reference Value = 27.732 V/m; Power Drift = -0.033 dB

Peak SAR (extrapolated) = 1.027 W/kg

SAR(1 g) = 0.746 mW/g; SAR(10 g) = 0.552 mW/g

Maximum value of SAR (measured) = 0.782 mW/g

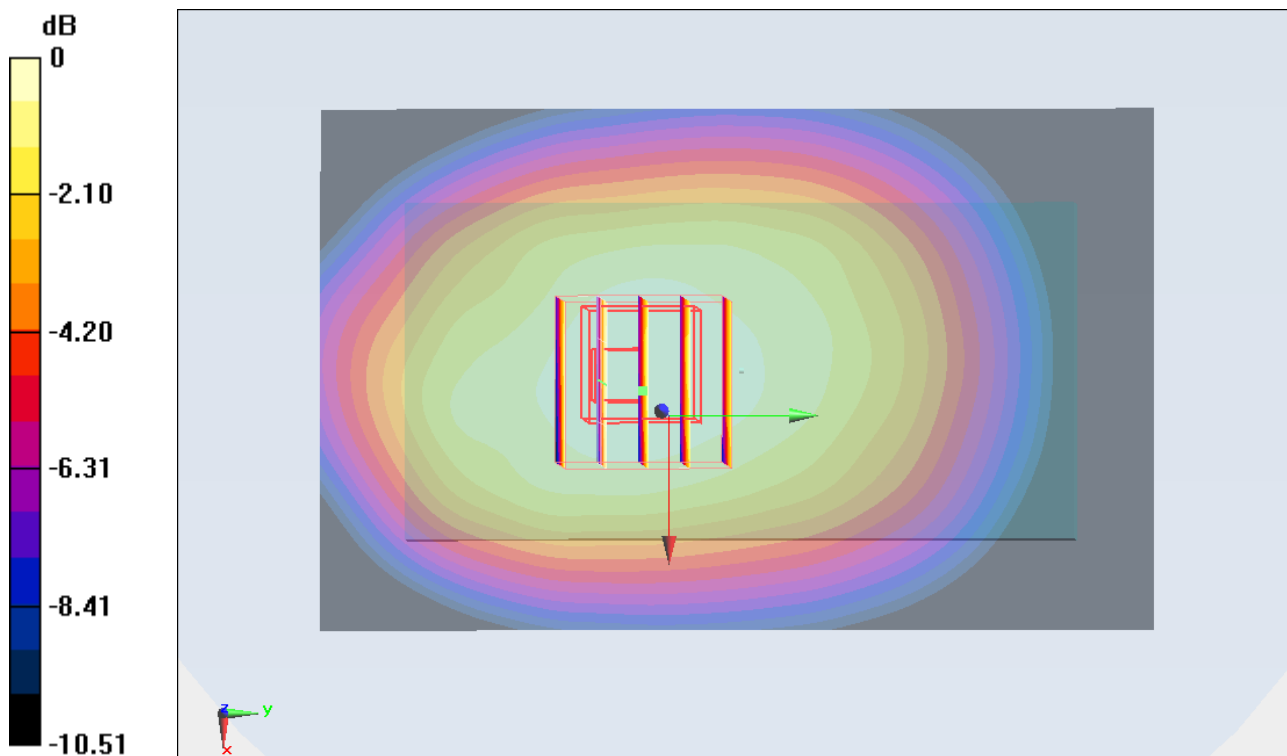

0 dB = 0.780mW/g

#34 CDMA2000 BC0_RC3+SO32_Back_1cm_Ch777

DUT: 181934

Communication System: CDMA ; Frequency: 848.31 MHz;Duty Cycle: 1:1

Medium: MSL_850_111004 Medium parameters used : $f = 848.31$ MHz; $\sigma = 0.968$ mho/m; $\epsilon_r =$

52.555 ; $\rho = 1000$ kg/m³

Ambient Temperature : 22.5 °C ; Liquid Temperature : 21.5 °C

DASY5 Configuration:

- Probe: ES3DV3 - SN3270; ConvF(6.16, 6.16, 6.16); Calibrated: 2011/9/12
- Sensor-Surface: 4mm (Mechanical Surface Detection)
- Electronics: DAE3 Sn495; Calibrated: 2011/4/28
- Phantom: SAM Right; Type: QD000P40CD; Serial: TP:1644
- Measurement SW: DASY52, Version 52.6 (2); SEMCAD X Version 14.4.5 (3634)

Ch777/Area Scan (51x81x1): Measurement grid: dx=20mm, dy=20mm

Maximum value of SAR (interpolated) = 0.839 mW/g

Ch777/Zoom Scan (5x5x7)/Cube 0: Measurement grid: dx=8mm, dy=8mm, dz=5mm

Reference Value = 28.234 V/m; Power Drift = -0.10 dB

Peak SAR (extrapolated) = 1.066 W/kg

SAR(1 g) = 0.781 mW/g; SAR(10 g) = 0.570 mW/g

Maximum value of SAR (measured) = 0.815 mW/g

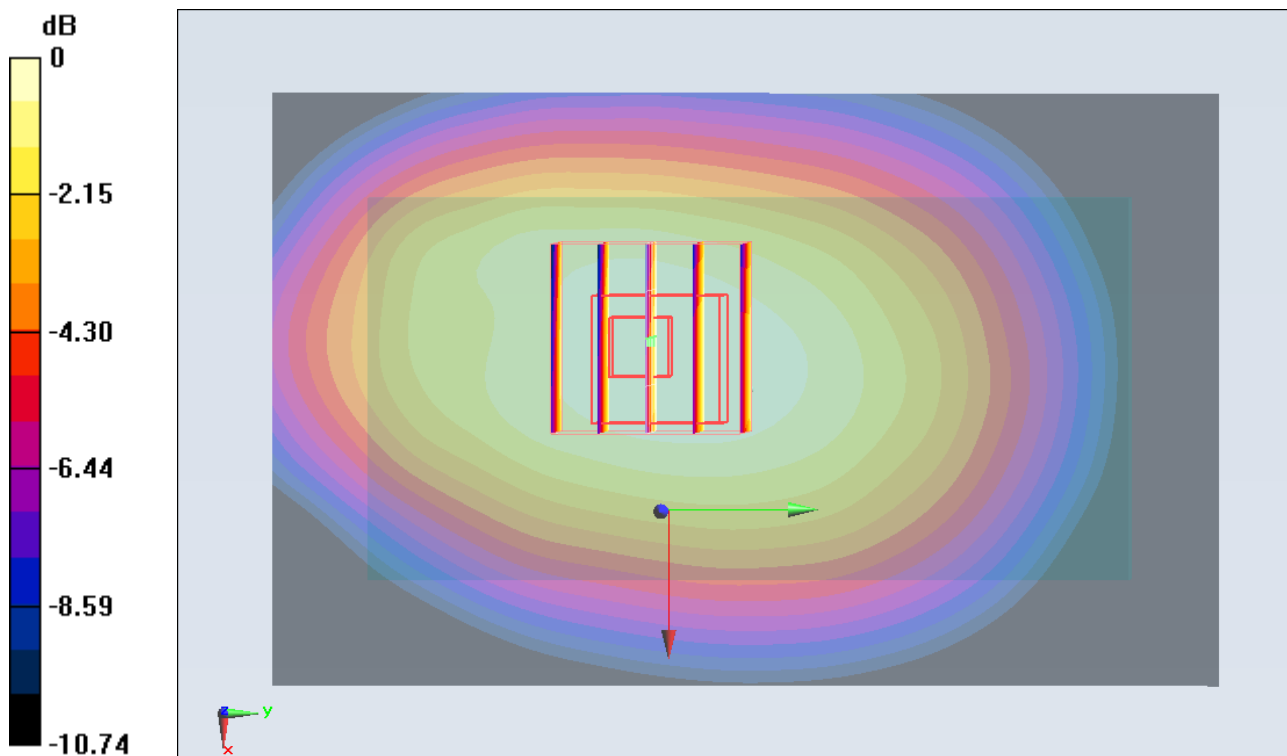

0 dB = 0.810mW/g

#34 CDMA2000 BC0_RC3+SO32_Back_1cm_Ch777_2D

DUT: 181934

Communication System: CDMA ; Frequency: 848.31 MHz; Duty Cycle: 1:1
Medium: MSL_850_111004 Medium parameters used : $f = 848.31$ MHz; $\sigma = 0.968$ mho/m; $\epsilon_r = 52.555$; $\rho = 1000$ kg/m³
Ambient Temperature : 22.5 °C ; Liquid Temperature : 21.5 °C

DASY5 Configuration:

- Probe: ES3DV3 - SN3270; ConvF(6.16, 6.16, 6.16); Calibrated: 2011/9/12
- Sensor-Surface: 4mm (Mechanical Surface Detection)
- Electronics: DAE3 Sn495; Calibrated: 2011/4/28
- Phantom: SAM Right; Type: QD000P40CD; Serial: TP:1644
- Measurement SW: DASY52, Version 52.6 (2); SEMCAD X Version 14.4.5 (3634)

Ch777/Area Scan (51x81x1): Measurement grid: dx=20mm, dy=20mm
Maximum value of SAR (interpolated) = 0.839 mW/g

Ch777/Zoom Scan (5x5x7)/Cube 0: Measurement grid: dx=8mm, dy=8mm, dz=5mm
Reference Value = 28.234 V/m; Power Drift = -0.10 dB
Peak SAR (extrapolated) = 1.066 W/kg
SAR(1 g) = 0.781 mW/g; SAR(10 g) = 0.570 mW/g
Maximum value of SAR (measured) = 0.815 mW/g

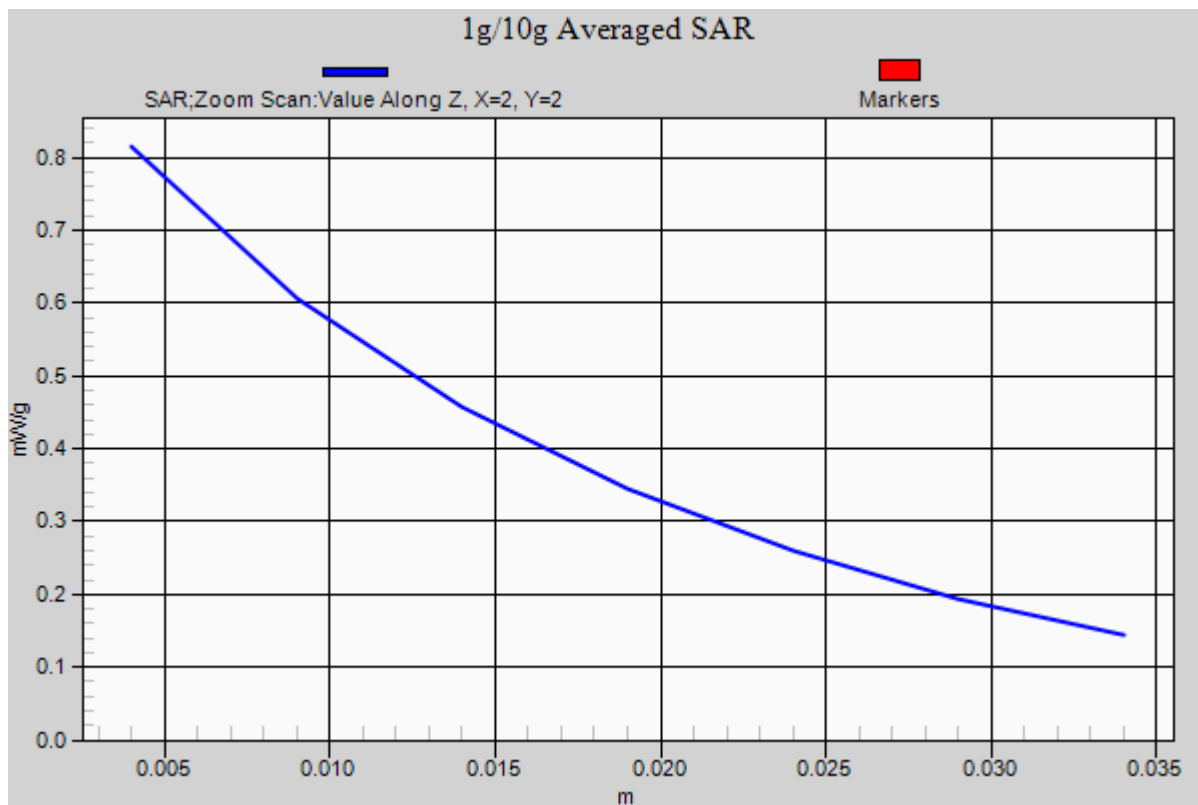

#35 CDMA2000 BC0_RC3+SO32_Left Side_1cm_Ch777

DUT: 181934

Communication System: CDMA ; Frequency: 848.31 MHz;Duty Cycle: 1:1

Medium: MSL_850_111004 Medium parameters used : $f = 848.31$ MHz; $\sigma = 0.968$ mho/m; $\epsilon_r =$

52.555 ; $\rho = 1000$ kg/m³

Ambient Temperature : 22.5 °C ; Liquid Temperature : 21.5 °C

DASY5 Configuration:

- Probe: ES3DV3 - SN3270; ConvF(6.16, 6.16, 6.16); Calibrated: 2011/9/12
- Sensor-Surface: 4mm (Mechanical Surface Detection)
- Electronics: DAE3 Sn495; Calibrated: 2011/4/28
- Phantom: SAM Right; Type: QD000P40CD; Serial: TP:1644
- Measurement SW: DASY52, Version 52.6 (2); SEMCAD X Version 14.4.5 (3634)

Ch777/Area Scan (31x81x1): Measurement grid: dx=20mm, dy=20mm

Maximum value of SAR (interpolated) = 0.616 mW/g

Ch777/Zoom Scan (5x5x7)/Cube 0: Measurement grid: dx=8mm, dy=8mm, dz=5mm

Reference Value = 25.618 V/m; Power Drift = -0.132 dB

Peak SAR (extrapolated) = 0.877 W/kg

SAR(1 g) = 0.592 mW/g; SAR(10 g) = 0.402 mW/g

Maximum value of SAR (measured) = 0.630 mW/g

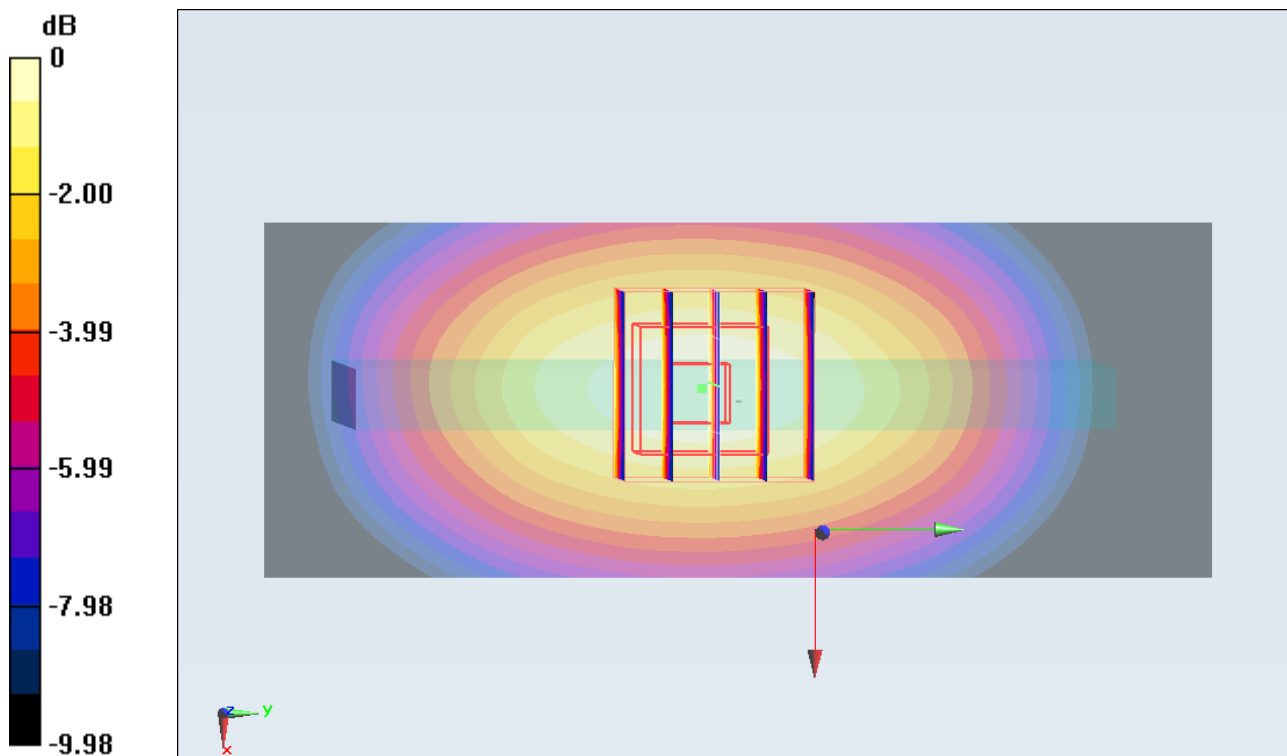

0 dB = 0.630mW/g

#36 CDMA2000 BC0_RC3+SO32_Right Side_1cm_Ch777

DUT: 181934

Communication System: CDMA ; Frequency: 848.31 MHz; Duty Cycle: 1:1
Medium: MSL_850_111004 Medium parameters used : $f = 848.31$ MHz; $\sigma = 0.968$ mho/m; $\epsilon_r = 52.555$; $\rho = 1000$ kg/m³
Ambient Temperature : 22.5 °C ; Liquid Temperature : 21.5 °C

DASY5 Configuration:

- Probe: ES3DV3 - SN3270; ConvF(6.16, 6.16, 6.16); Calibrated: 2011/9/12
- Sensor-Surface: 4mm (Mechanical Surface Detection)
- Electronics: DAE3 Sn495; Calibrated: 2011/4/28
- Phantom: SAM Right; Type: QD000P40CD; Serial: TP:1644
- Measurement SW: DASY52, Version 52.6 (2); SEMCAD X Version 14.4.5 (3634)

Ch777/Area Scan (31x81x1): Measurement grid: dx=20mm, dy=20mm
Maximum value of SAR (interpolated) = 0.654 mW/g

Ch777/Zoom Scan (5x5x7)/Cube 0: Measurement grid: dx=8mm, dy=8mm, dz=5mm
Reference Value = 25.997 V/m; Power Drift = -0.130 dB
Peak SAR (extrapolated) = 0.868 W/kg
SAR(1 g) = 0.590 mW/g; SAR(10 g) = 0.399 mW/g
Maximum value of SAR (measured) = 0.632 mW/g

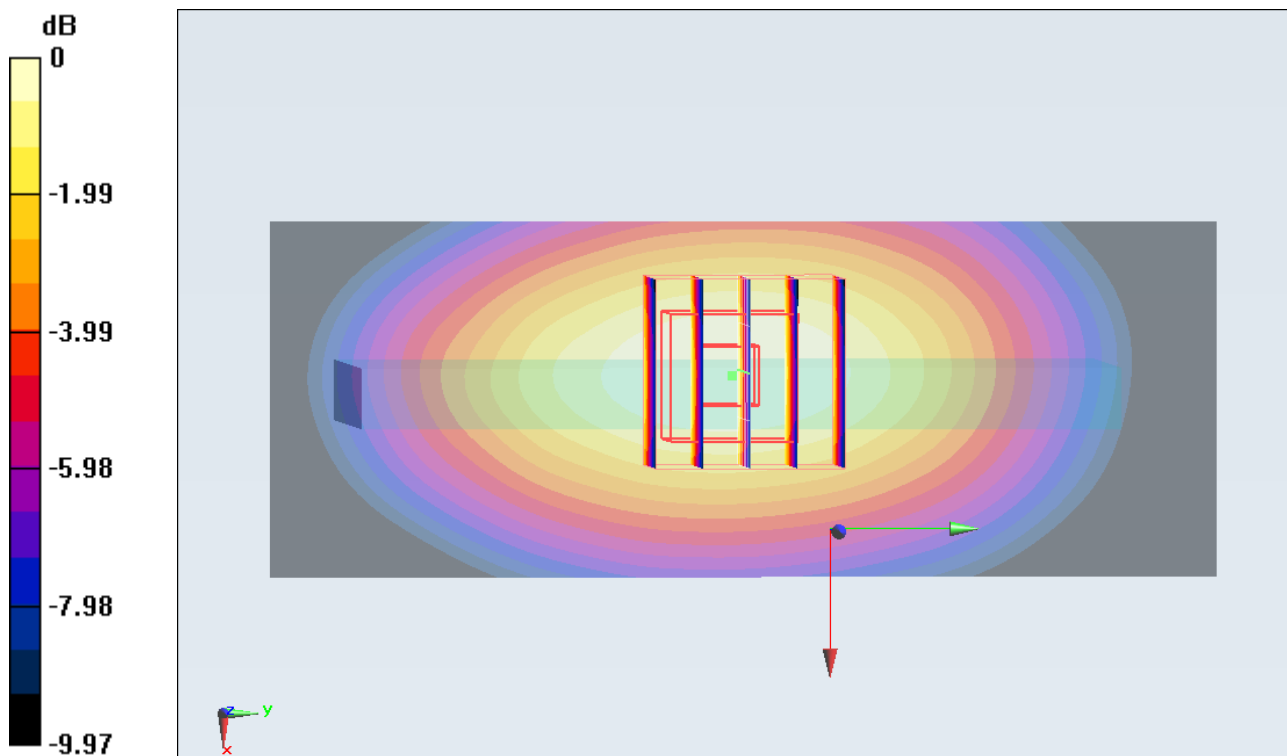

0 dB = 0.630mW/g

#37 CDMA2000 BC0_RC3+SO32_Top Side_1cm_Ch777

DUT: 181934

Communication System: CDMA ; Frequency: 848.31 MHz;Duty Cycle: 1:1

Medium: MSL_850_111004 Medium parameters used : $f = 848.31$ MHz; $\sigma = 0.968$ mho/m; $\epsilon_r =$

52.555 ; $\rho = 1000$ kg/m³

Ambient Temperature : 22.5 °C ; Liquid Temperature : 21.5 °C

DASY5 Configuration:

- Probe: ES3DV3 - SN3270; ConvF(6.16, 6.16, 6.16); Calibrated: 2011/9/12
- Sensor-Surface: 4mm (Mechanical Surface Detection)
- Electronics: DAE3 Sn495; Calibrated: 2011/4/28
- Phantom: SAM Right; Type: QD000P40CD; Serial: TP:1644
- Measurement SW: DASY52, Version 52.6 (2); SEMCAD X Version 14.4.5 (3634)

Ch777/Area Scan (31x51x1): Measurement grid: dx=20mm, dy=20mm

Maximum value of SAR (interpolated) = 0.033 mW/g

Ch777/Zoom Scan (5x5x7)/Cube 0: Measurement grid: dx=8mm, dy=8mm, dz=5mm

Reference Value = 4.187 V/m; Power Drift = 0.14 dB

Peak SAR (extrapolated) = 0.050 W/kg

SAR(1 g) = 0.033 mW/g; SAR(10 g) = 0.024 mW/g

Maximum value of SAR (measured) = 0.035 mW/g

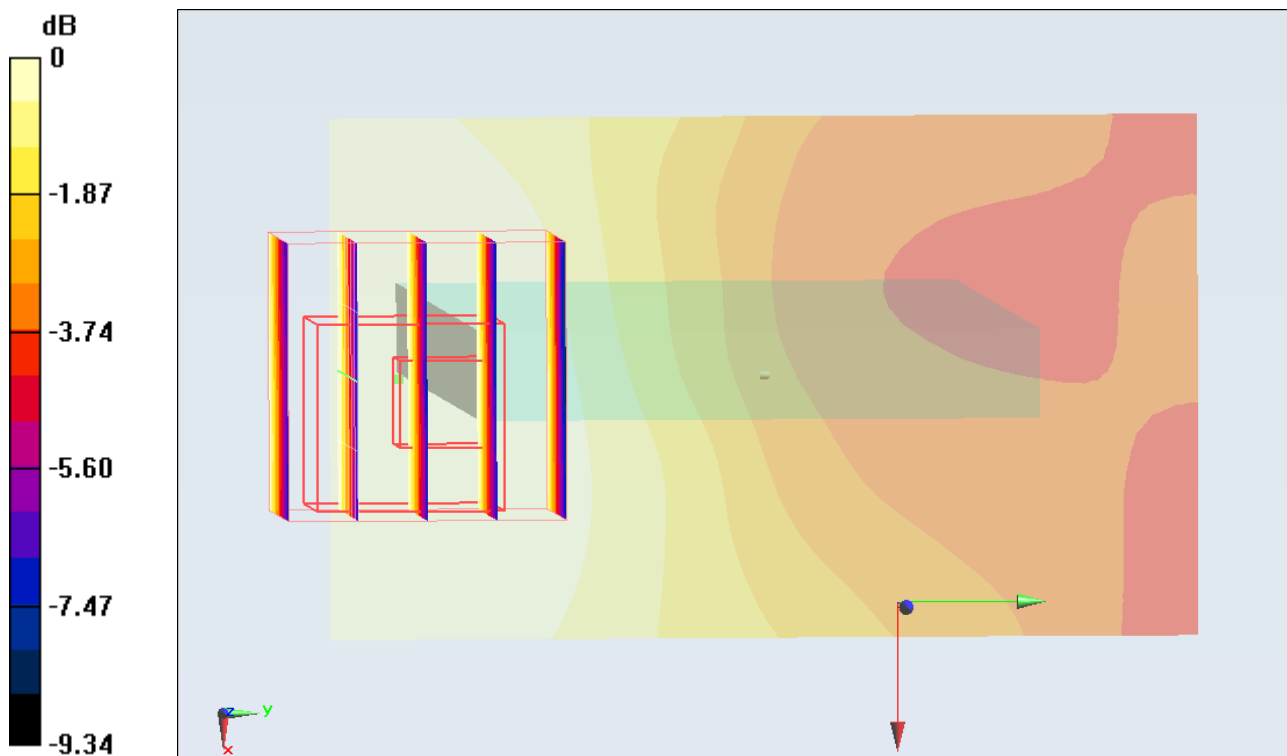

0 dB = 0.030mW/g

#38 CDMA2000 BC0_RC3+SO32_Down Side_1cm_Ch777

DUT: 181934

Communication System: CDMA ; Frequency: 848.31 MHz;Duty Cycle: 1:1

Medium: MSL_850_111004 Medium parameters used : $f = 848.31$ MHz; $\sigma = 0.968$ mho/m; $\epsilon_r =$

52.555 ; $\rho = 1000$ kg/m³

Ambient Temperature : 22.5 °C ; Liquid Temperature : 21.5 °C

DASY5 Configuration:

- Probe: ES3DV3 - SN3270; ConvF(6.16, 6.16, 6.16); Calibrated: 2011/9/12
- Sensor-Surface: 4mm (Mechanical Surface Detection)
- Electronics: DAE3 Sn495; Calibrated: 2011/4/28
- Phantom: SAM Right; Type: QD000P40CD; Serial: TP:1644
- Measurement SW: DASY52, Version 52.6 (2); SEMCAD X Version 14.4.5 (3634)

Ch777/Area Scan (31x41x1): Measurement grid: dx=20mm, dy=20mm

Maximum value of SAR (interpolated) = 0.161 mW/g

Ch777/Zoom Scan (5x5x7)/Cube 0: Measurement grid: dx=8mm, dy=8mm, dz=5mm

Reference Value = 14.825 V/m; Power Drift = 0.05 dB

Peak SAR (extrapolated) = 0.372 W/kg

SAR(1 g) = 0.197 mW/g; SAR(10 g) = 0.102 mW/g

Maximum value of SAR (measured) = 0.200 mW/g

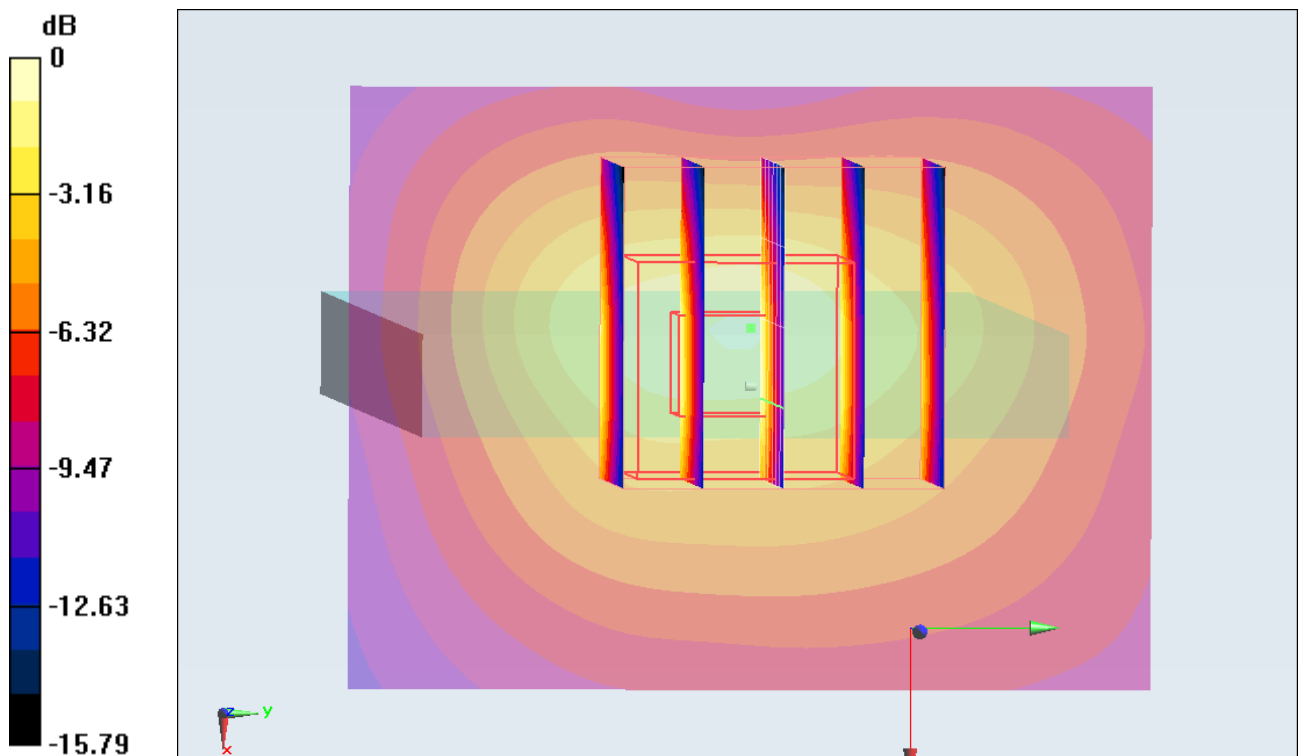

0 dB = 0.200mW/g

#33 CDMA2000 BC0_RC3+SO32_Front_1cm_Ch777

DUT: 181934

Communication System: CDMA ; Frequency: 848.31 MHz;Duty Cycle: 1:1

Medium: MSL_850_111004 Medium parameters used : $f = 848.31$ MHz; $\sigma = 0.968$ mho/m; $\epsilon_r =$

52.555 ; $\rho = 1000$ kg/m³

Ambient Temperature : 22.5 °C ; Liquid Temperature : 21.5 °C

DASY5 Configuration:

- Probe: ES3DV3 - SN3270; ConvF(6.16, 6.16, 6.16); Calibrated: 2011/9/12
- Sensor-Surface: 4mm (Mechanical Surface Detection)
- Electronics: DAE3 Sn495; Calibrated: 2011/4/28
- Phantom: SAM Right; Type: QD000P40CD; Serial: TP:1644
- Measurement SW: DASY52, Version 52.6 (2); SEMCAD X Version 14.4.5 (3634)

Ch777/Area Scan (51x81x1): Measurement grid: dx=20mm, dy=20mm

Maximum value of SAR (interpolated) = 0.806 mW/g

Ch777/Zoom Scan (5x5x7)/Cube 0: Measurement grid: dx=8mm, dy=8mm, dz=5mm

Reference Value = 27.732 V/m; Power Drift = -0.033 dB

Peak SAR (extrapolated) = 1.027 W/kg

SAR(1 g) = 0.746 mW/g; SAR(10 g) = 0.552 mW/g

Maximum value of SAR (measured) = 0.782 mW/g

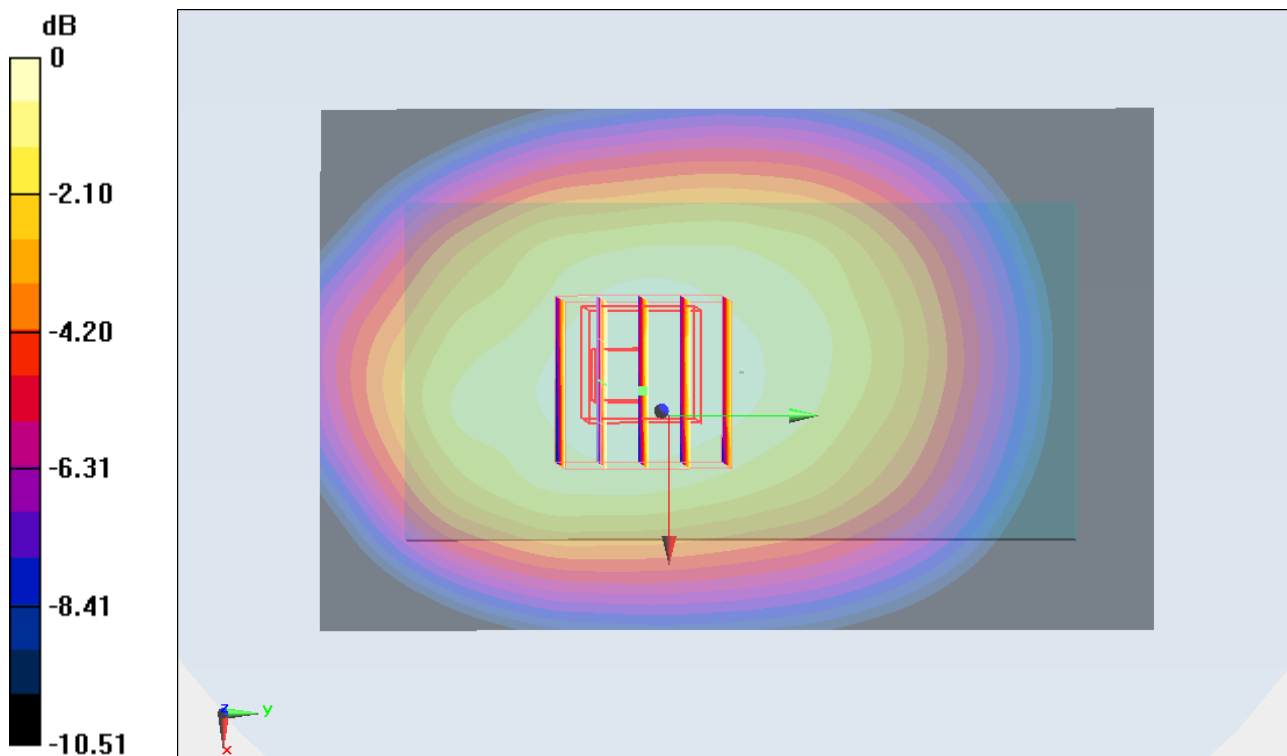

0 dB = 0.780mW/g

#34 CDMA2000 BC0_RC3+SO32_Back_1cm_Ch777

DUT: 181934

Communication System: CDMA ; Frequency: 848.31 MHz;Duty Cycle: 1:1

Medium: MSL_850_111004 Medium parameters used : $f = 848.31$ MHz; $\sigma = 0.968$ mho/m; $\epsilon_r =$

52.555 ; $\rho = 1000$ kg/m³

Ambient Temperature : 22.5 °C ; Liquid Temperature : 21.5 °C

DASY5 Configuration:

- Probe: ES3DV3 - SN3270; ConvF(6.16, 6.16, 6.16); Calibrated: 2011/9/12
- Sensor-Surface: 4mm (Mechanical Surface Detection)
- Electronics: DAE3 Sn495; Calibrated: 2011/4/28
- Phantom: SAM Right; Type: QD000P40CD; Serial: TP:1644
- Measurement SW: DASY52, Version 52.6 (2); SEMCAD X Version 14.4.5 (3634)

Ch777/Area Scan (51x81x1): Measurement grid: dx=20mm, dy=20mm

Maximum value of SAR (interpolated) = 0.839 mW/g

Ch777/Zoom Scan (5x5x7)/Cube 0: Measurement grid: dx=8mm, dy=8mm, dz=5mm

Reference Value = 28.234 V/m; Power Drift = -0.10 dB

Peak SAR (extrapolated) = 1.066 W/kg

SAR(1 g) = 0.781 mW/g; SAR(10 g) = 0.570 mW/g

Maximum value of SAR (measured) = 0.815 mW/g

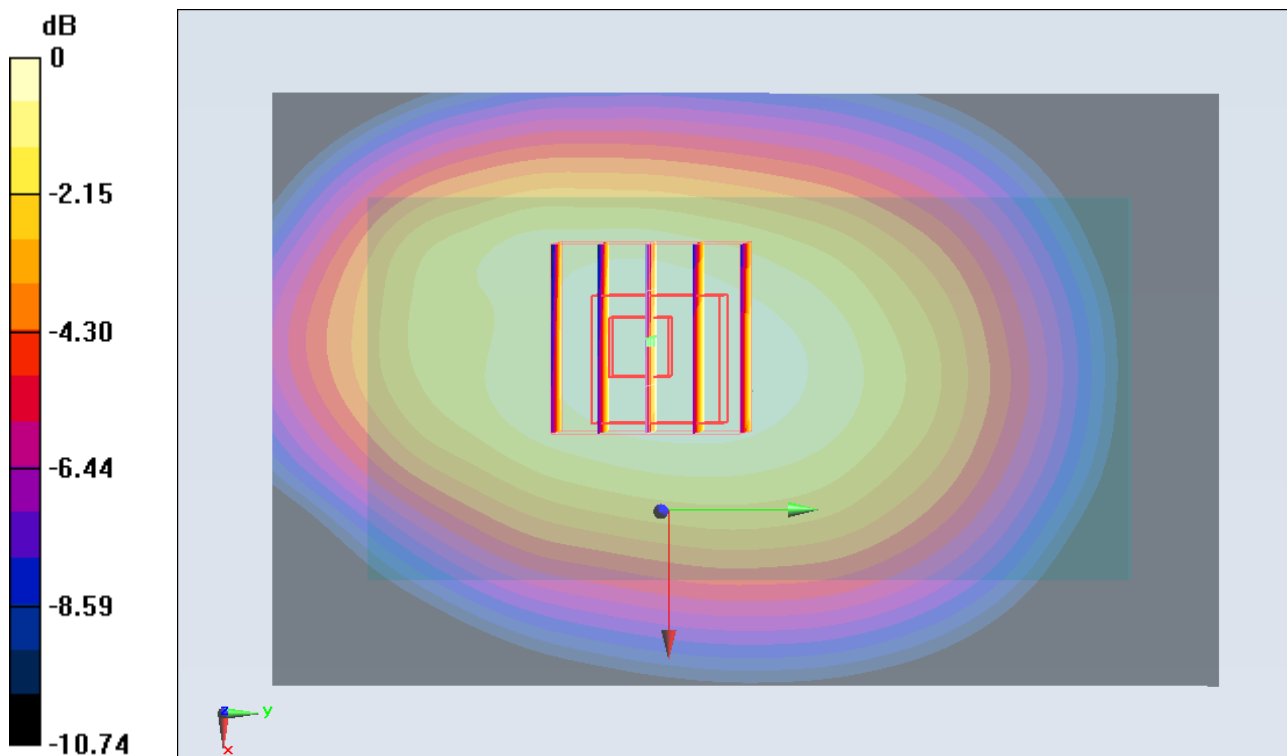

0 dB = 0.810mW/g

#34 CDMA2000 BC0_RC3+SO32_Back_1cm_Ch777_2D

DUT: 181934

Communication System: CDMA ; Frequency: 848.31 MHz;Duty Cycle: 1:1
Medium: MSL_850_111004 Medium parameters used : $f = 848.31$ MHz; $\sigma = 0.968$ mho/m; $\epsilon_r = 52.555$; $\rho = 1000$ kg/m³
Ambient Temperature : 22.5 °C ; Liquid Temperature : 21.5 °C

DASY5 Configuration:

- Probe: ES3DV3 - SN3270; ConvF(6.16, 6.16, 6.16); Calibrated: 2011/9/12
- Sensor-Surface: 4mm (Mechanical Surface Detection)
- Electronics: DAE3 Sn495; Calibrated: 2011/4/28
- Phantom: SAM Right; Type: QD000P40CD; Serial: TP:1644
- Measurement SW: DASY52, Version 52.6 (2); SEMCAD X Version 14.4.5 (3634)

Ch777/Area Scan (51x81x1): Measurement grid: dx=20mm, dy=20mm
Maximum value of SAR (interpolated) = 0.839 mW/g

Ch777/Zoom Scan (5x5x7)/Cube 0: Measurement grid: dx=8mm, dy=8mm, dz=5mm
Reference Value = 28.234 V/m; Power Drift = -0.10 dB
Peak SAR (extrapolated) = 1.066 W/kg
SAR(1 g) = 0.781 mW/g; SAR(10 g) = 0.570 mW/g
Maximum value of SAR (measured) = 0.815 mW/g

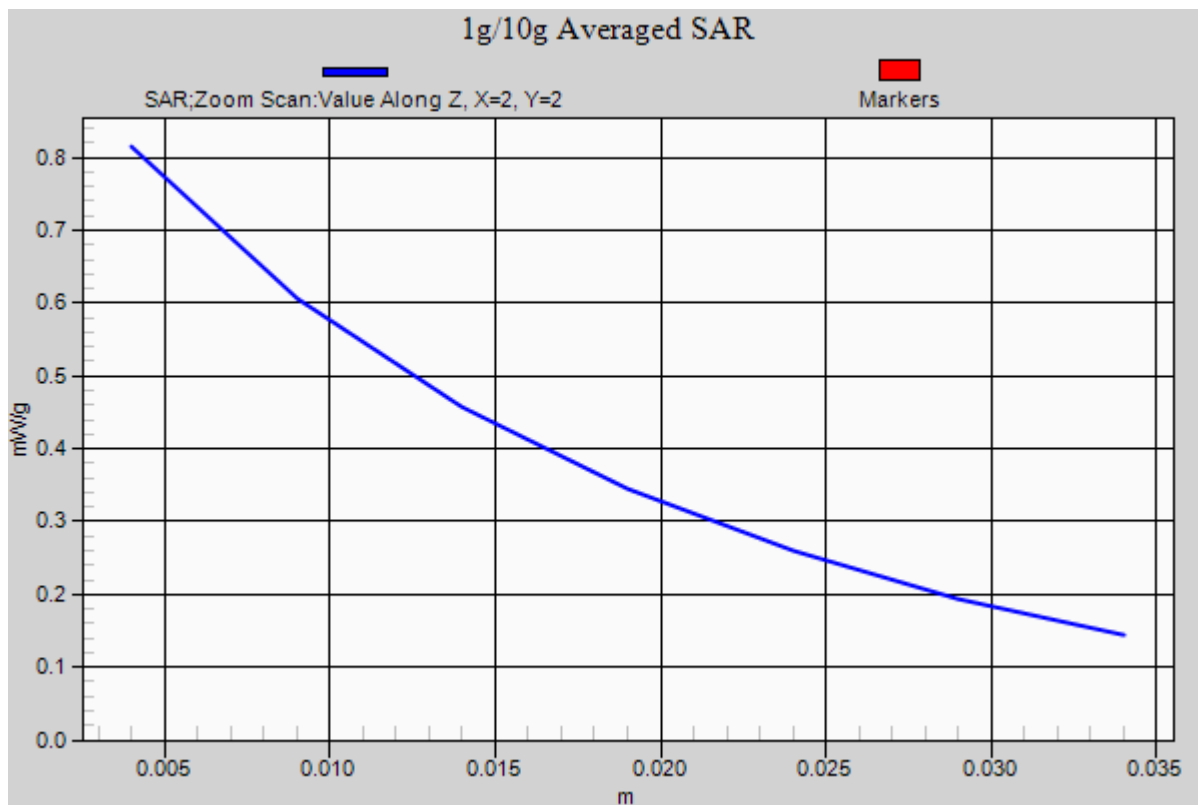

#39 CDMA2000 BC0_RC3+SO32_Back_1cm_Ch777_Earphone

DUT: 181934

Communication System: CDMA ; Frequency: 848.31 MHz; Duty Cycle: 1:1

Medium: MSL_850_111004 Medium parameters used: $f = 848.31$ MHz; $\sigma = 0.968$ mho/m; $\epsilon_r =$

52.555 ; $\rho = 1000$ kg/m³

Ambient Temperature : 22.5 °C ; Liquid Temperature : 21.5 °C

DASY5 Configuration:

- Probe: ES3DV3 - SN3270; ConvF(6.16, 6.16, 6.16); Calibrated: 2011/9/12
- Sensor-Surface: 4mm (Mechanical Surface Detection)
- Electronics: DAE3 Sn495; Calibrated: 2011/4/28
- Phantom: SAM Right; Type: QD000P40CD; Serial: TP:1644
- Measurement SW: DASY52, Version 52.6 (2); SEMCAD X Version 14.4.5 (3634)

Ch777/Area Scan (51x81x1): Measurement grid: dx=20mm, dy=20mm

Maximum value of SAR (interpolated) = 0.776 mW/g

Ch777/Zoom Scan (5x5x7)/Cube 0: Measurement grid: dx=8mm, dy=8mm, dz=5mm

Reference Value = 19.620 V/m; Power Drift = -0.04 dB

Peak SAR (extrapolated) = 1.194 W/kg

SAR(1 g) = 0.727 mW/g; SAR(10 g) = 0.470 mW/g

Maximum value of SAR (measured) = 0.766 mW/g

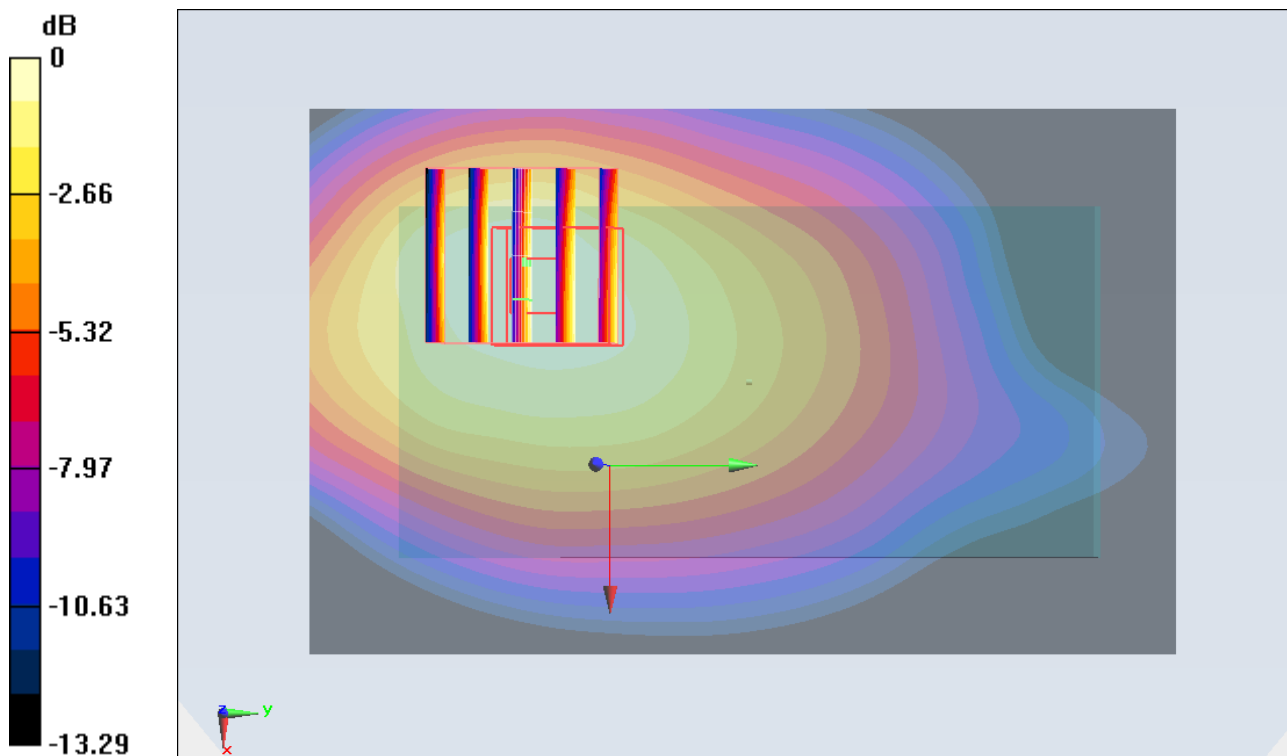

0 dB = 0.770mW/g

#12 GSM1900_GPRS12_Front_1cm_Ch810

DUT: 181934

Communication System: PCS; Frequency: 1909.8 MHz; Duty Cycle: 1:2

Medium: MSL_1900_111003 Medium parameters used: $f = 1910$ MHz; $\sigma = 1.55$ mho/m; $\epsilon_r = 51.9$; $\rho = 1000$ kg/m³

Ambient Temperature : 22.3 °C; Liquid Temperature : 21.3 °C

DASY4 Configuration:

- Probe: EX3DV4 - SN3697; ConvF(6.96, 6.96, 6.96); Calibrated: 2011-09-02
- Sensor-Surface: 4mm (Mechanical Surface Detection)
- Electronics: DAE4 Sn905; Calibrated: 2011-06-24
- Phantom: SAM_Right; Type: SAM; Serial: TP-1303
- Measurement SW: DASY4, V4.7 Build 80; Postprocessing SW: SEMCAD, V1.8 Build 186

Ch810/Area Scan (51x81x1): Measurement grid: dx=20mm, dy=20mm

Maximum value of SAR (interpolated) = 1.18 mW/g

Ch810/Zoom Scan (5x5x7)/Cube 0: Measurement grid: dx=8mm, dy=8mm, dz=5mm

Reference Value = 8.86 V/m; Power Drift = -0.086 dB

Peak SAR (extrapolated) = 1.65 W/kg

SAR(1 g) = 0.993 mW/g; SAR(10 g) = 0.554 mW/g

Maximum value of SAR (measured) = 1.04 mW/g

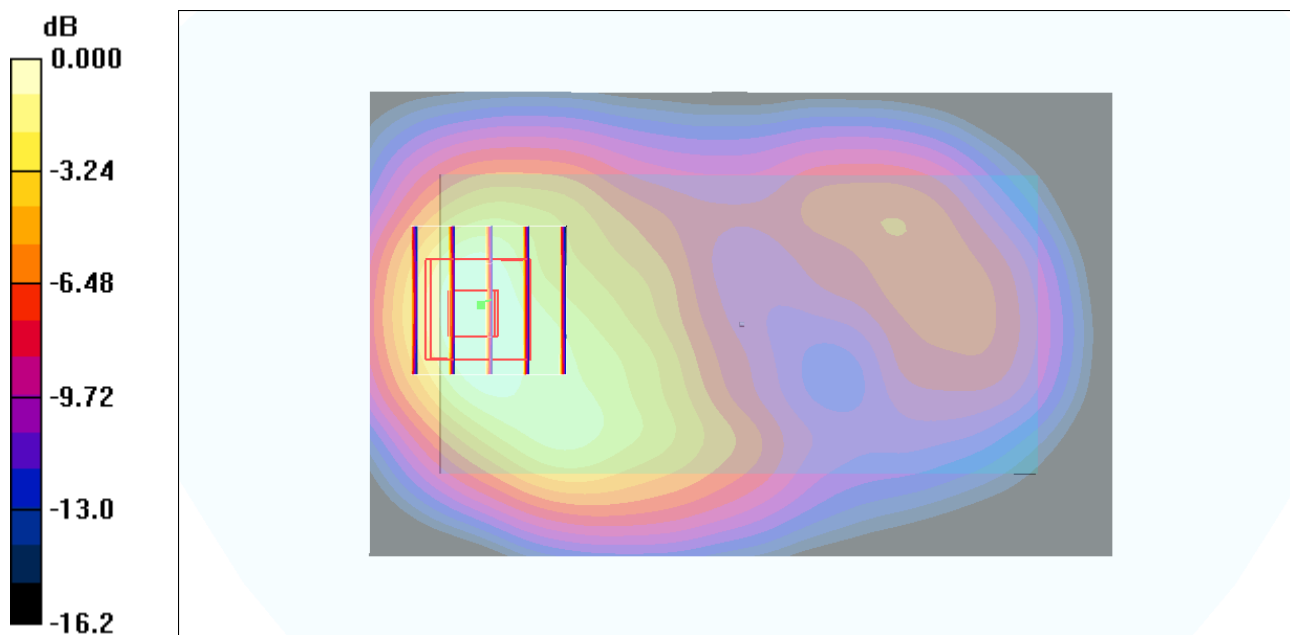

#19 GSM1900_GPRS12_Front_1cm_Ch512

DUT: 181934

Communication System: PCS; Frequency: 1850.2 MHz; Duty Cycle: 1:2

Medium: MSL_1900_111003 Medium parameters used: $f = 1850.2$ MHz; $\sigma = 1.5$ mho/m; $\epsilon_r = 52.2$; $\rho = 1000$ kg/m³

Ambient Temperature : 22.3 °C ; Liquid Temperature : 21.3 °C

DASY4 Configuration:

- Probe: EX3DV4 - SN3697; ConvF(6.96, 6.96, 6.96); Calibrated: 2011-09-02
- Sensor-Surface: 4mm (Mechanical Surface Detection)
- Electronics: DAE4 Sn905; Calibrated: 2011-06-24
- Phantom: SAM_Right; Type: SAM; Serial: TP-1303
- Measurement SW: DASY4, V4.7 Build 80; Postprocessing SW: SEMCAD, V1.8 Build 186

Ch512/Area Scan (51x81x1): Measurement grid: dx=20mm, dy=20mm

Maximum value of SAR (interpolated) = 0.746 mW/g

Ch512/Zoom Scan (5x5x7)/Cube 0: Measurement grid: dx=8mm, dy=8mm, dz=5mm

Reference Value = 7.34 V/m; Power Drift = -0.121 dB

Peak SAR (extrapolated) = 1.02 W/kg

SAR(1 g) = 0.627 mW/g; SAR(10 g) = 0.348 mW/g

Maximum value of SAR (measured) = 0.641 mW/g

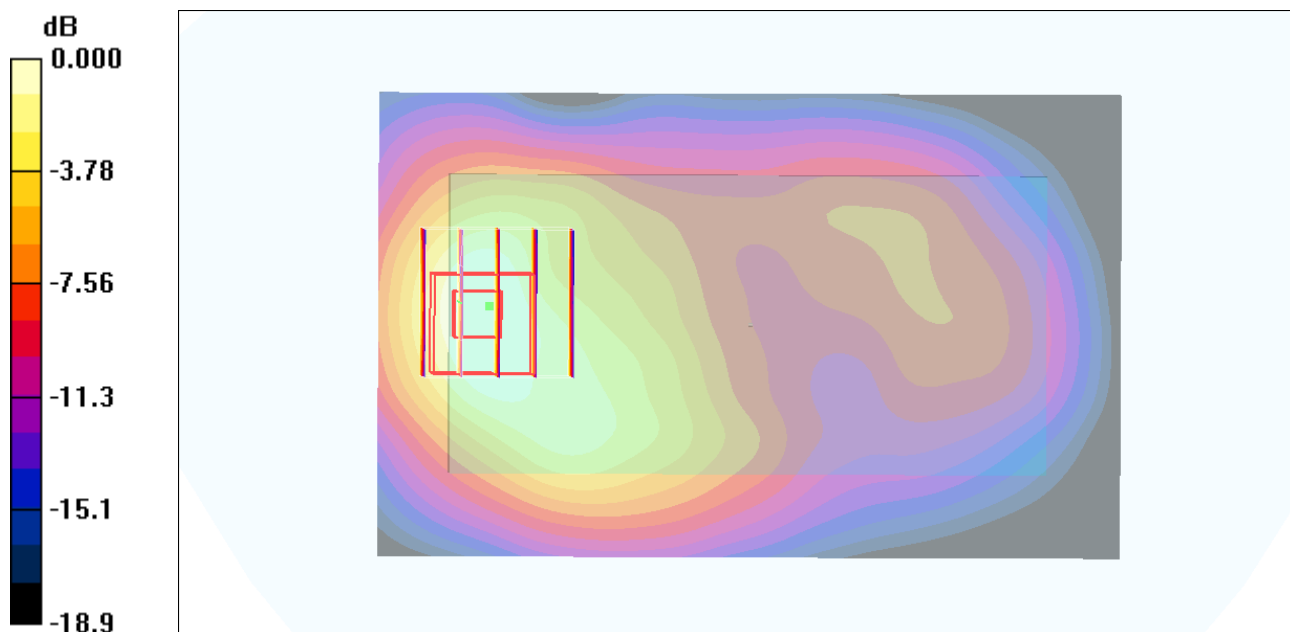

0 dB = 0.641mW/g

#20 GSM1900_GPRS12_Front_1cm_Ch661

DUT: 181934

Communication System: PCS; Frequency: 1880 MHz; Duty Cycle: 1:2

Medium: MSL_1900_111003 Medium parameters used: $f = 1880$ MHz; $\sigma = 1.53$ mho/m; $\epsilon_r = 52$; $\rho = 1000$ kg/m³

Ambient Temperature : 22.3 °C; Liquid Temperature : 21.3 °C

DASY4 Configuration:

- Probe: EX3DV4 - SN3697; ConvF(6.96, 6.96, 6.96); Calibrated: 2011-09-02
- Sensor-Surface: 4mm (Mechanical Surface Detection)
- Electronics: DAE4 Sn905; Calibrated: 2011-06-24
- Phantom: SAM_Right; Type: SAM; Serial: TP-1303
- Measurement SW: DASY4, V4.7 Build 80; Postprocessing SW: SEMCAD, V1.8 Build 186

Ch661/Area Scan (51x81x1): Measurement grid: dx=20mm, dy=20mm

Maximum value of SAR (interpolated) = 0.969 mW/g

Ch661/Zoom Scan (5x5x7)/Cube 0: Measurement grid: dx=8mm, dy=8mm, dz=5mm

Reference Value = 7.86 V/m; Power Drift = -0.089 dB

Peak SAR (extrapolated) = 1.29 W/kg

SAR(1 g) = 0.797 mW/g; SAR(10 g) = 0.449 mW/g

Maximum value of SAR (measured) = 0.831 mW/g

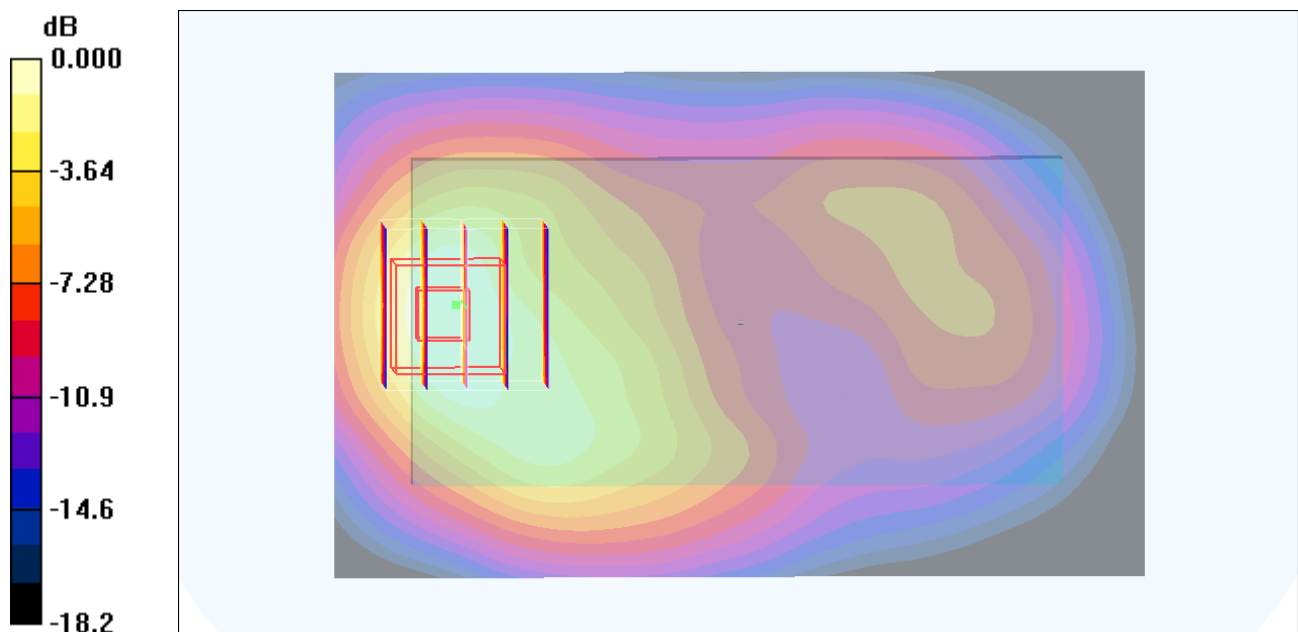

0 dB = 0.831mW/g

#13 GSM1900_GPRS12_Back_1cm_Ch810

DUT: 181934

Communication System: PCS; Frequency: 1909.8 MHz; Duty Cycle: 1:2

Medium: MSL_1900_111003 Medium parameters used: $f = 1910$ MHz; $\sigma = 1.55$ mho/m; $\epsilon_r = 51.9$; $\rho = 1000$ kg/m³

Ambient Temperature : 22.3 °C; Liquid Temperature : 21.3 °C

DASY4 Configuration:

- Probe: EX3DV4 - SN3697; ConvF(6.96, 6.96, 6.96); Calibrated: 2011-09-02
- Sensor-Surface: 4mm (Mechanical Surface Detection)
- Electronics: DAE4 Sn905; Calibrated: 2011-06-24
- Phantom: SAM_Right; Type: SAM; Serial: TP-1303
- Measurement SW: DASY4, V4.7 Build 80; Postprocessing SW: SEMCAD, V1.8 Build 186

Ch810/Area Scan (51x81x1): Measurement grid: dx=20mm, dy=20mm

Maximum value of SAR (interpolated) = 1.08 mW/g

Ch810/Zoom Scan (5x5x7)/Cube 0: Measurement grid: dx=8mm, dy=8mm, dz=5mm

Reference Value = 8.44 V/m; Power Drift = -0.096 dB

Peak SAR (extrapolated) = 1.44 W/kg

SAR(1 g) = 0.884 mW/g; SAR(10 g) = 0.501 mW/g

Maximum value of SAR (measured) = 0.909 mW/g

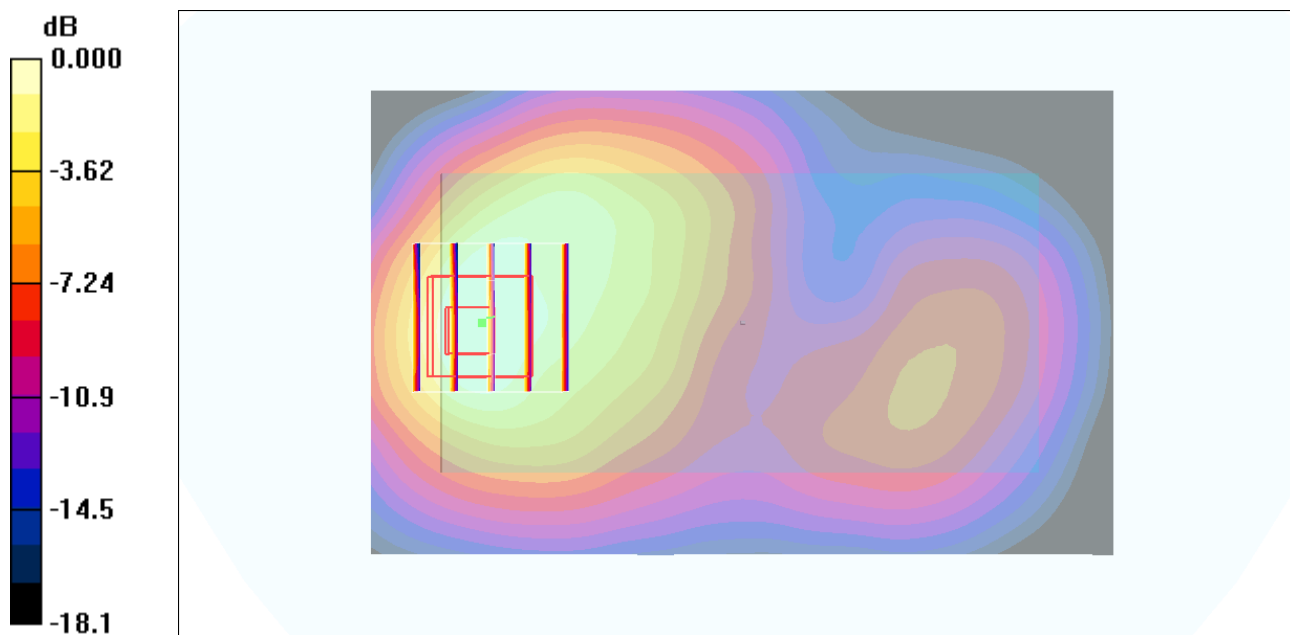

0 dB = 0.909mW/g

#21 GSM1900_GPRS12_Back_1cm_Ch512

DUT: 181934

Communication System: PCS; Frequency: 1850.2 MHz; Duty Cycle: 1:2

Medium: MSL_1900_111003 Medium parameters used: $f = 1850.2$ MHz; $\sigma = 1.5$ mho/m; $\epsilon_r = 52.2$; $\rho = 1000$ kg/m³

Ambient Temperature : 22.3 °C; Liquid Temperature : 21.3 °C

DASY4 Configuration:

- Probe: EX3DV4 - SN3697; ConvF(6.96, 6.96, 6.96); Calibrated: 2011-09-02
- Sensor-Surface: 4mm (Mechanical Surface Detection)
- Electronics: DAE4 Sn905; Calibrated: 2011-06-24
- Phantom: SAM_Right; Type: SAM; Serial: TP-1303
- Measurement SW: DASY4, V4.7 Build 80; Postprocessing SW: SEMCAD, V1.8 Build 186

Ch512/Area Scan (51x81x1): Measurement grid: dx=20mm, dy=20mm

Maximum value of SAR (interpolated) = 0.641 mW/g

Ch512/Zoom Scan (5x5x7)/Cube 0: Measurement grid: dx=8mm, dy=8mm, dz=5mm

Reference Value = 6.80 V/m; Power Drift = -0.123 dB

Peak SAR (extrapolated) = 0.844 W/kg

SAR(1 g) = 0.544 mW/g; SAR(10 g) = 0.303 mW/g

Maximum value of SAR (measured) = 0.587 mW/g

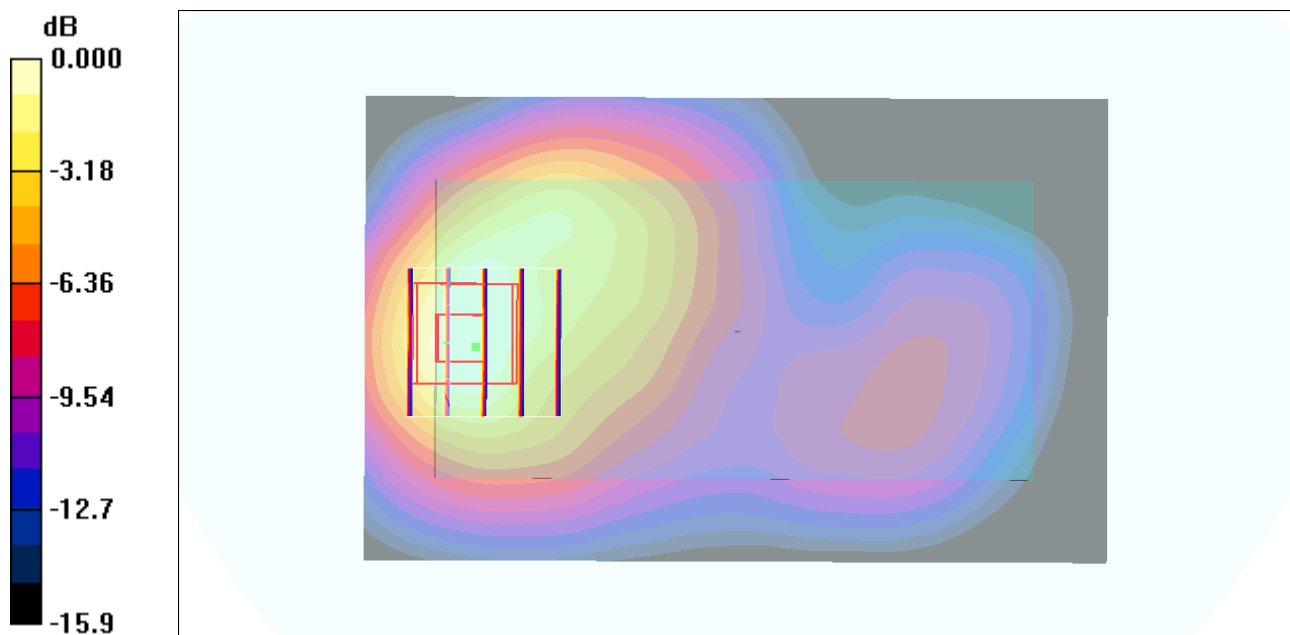

0 dB = 0.587mW/g

#22 GSM1900_GPRS12_Back_1cm_Ch661

DUT: 181934

Communication System: PCS; Frequency: 1880 MHz; Duty Cycle: 1:2

Medium: MSL_1900_111003 Medium parameters used: $f = 1880$ MHz; $\sigma = 1.53$ mho/m; $\epsilon_r = 52$; $\rho = 1000$ kg/m³

Ambient Temperature : 22.3 °C; Liquid Temperature : 21.3 °C

DASY4 Configuration:

- Probe: EX3DV4 - SN3697; ConvF(6.96, 6.96, 6.96); Calibrated: 2011-09-02
- Sensor-Surface: 4mm (Mechanical Surface Detection)
- Electronics: DAE4 Sn905; Calibrated: 2011-06-24
- Phantom: SAM_Right; Type: SAM; Serial: TP-1303
- Measurement SW: DASY4, V4.7 Build 80; Postprocessing SW: SEMCAD, V1.8 Build 186

Ch661/Area Scan (51x81x1): Measurement grid: dx=20mm, dy=20mm

Maximum value of SAR (interpolated) = 0.825 mW/g

Ch661/Zoom Scan (5x5x7)/Cube 0: Measurement grid: dx=8mm, dy=8mm, dz=5mm

Reference Value = 7.33 V/m; Power Drift = -0.122 dB

Peak SAR (extrapolated) = 1.12 W/kg

SAR(1 g) = 0.682 mW/g; SAR(10 g) = 0.383 mW/g

Maximum value of SAR (measured) = 0.713 mW/g

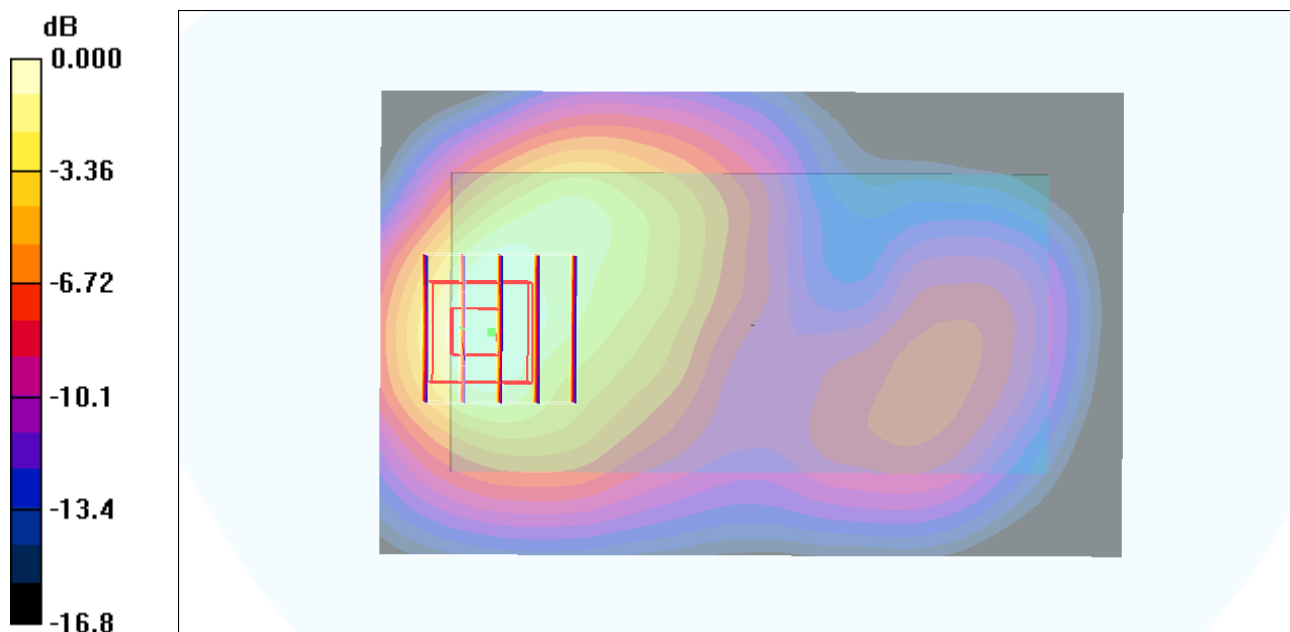

0 dB = 0.713mW/g

#14 GSM1900_GPRS12_Left Side_1cm_Ch810

DUT: 181934

Communication System: PCS; Frequency: 1909.8 MHz; Duty Cycle: 1:2

Medium: MSL_1900_111003 Medium parameters used: $f = 1910$ MHz; $\sigma = 1.55$ mho/m; $\epsilon_r = 51.9$; $\rho = 1000$ kg/m³

Ambient Temperature : 22.3 °C ; Liquid Temperature : 21.3 °C

DASY4 Configuration:

- Probe: EX3DV4 - SN3697; ConvF(6.96, 6.96, 6.96); Calibrated: 2011-09-02
- Sensor-Surface: 4mm (Mechanical Surface Detection)
- Electronics: DAE4 Sn905; Calibrated: 2011-06-24
- Phantom: SAM_Right; Type: SAM; Serial: TP-1303
- Measurement SW: DASY4, V4.7 Build 80; Postprocessing SW: SEMCAD, V1.8 Build 186

Ch810/Area Scan (31x81x1): Measurement grid: dx=20mm, dy=20mm

Maximum value of SAR (interpolated) = 0.137 mW/g

Ch810/Zoom Scan (5x5x7)/Cube 1: Measurement grid: dx=8mm, dy=8mm, dz=5mm

Reference Value = 6.74 V/m; Power Drift = -0.134 dB

Peak SAR (extrapolated) = 0.209 W/kg

SAR(1 g) = 0.129 mW/g; SAR(10 g) = 0.078 mW/g

Maximum value of SAR (measured) = 0.140 mW/g

Ch810/Zoom Scan (5x5x7)/Cube 0: Measurement grid: dx=8mm, dy=8mm, dz=5mm

Reference Value = 6.74 V/m; Power Drift = -0.134 dB

Peak SAR (extrapolated) = 0.200 W/kg

SAR(1 g) = 0.124 mW/g; SAR(10 g) = 0.071 mW/g

Maximum value of SAR (measured) = 0.135 mW/g

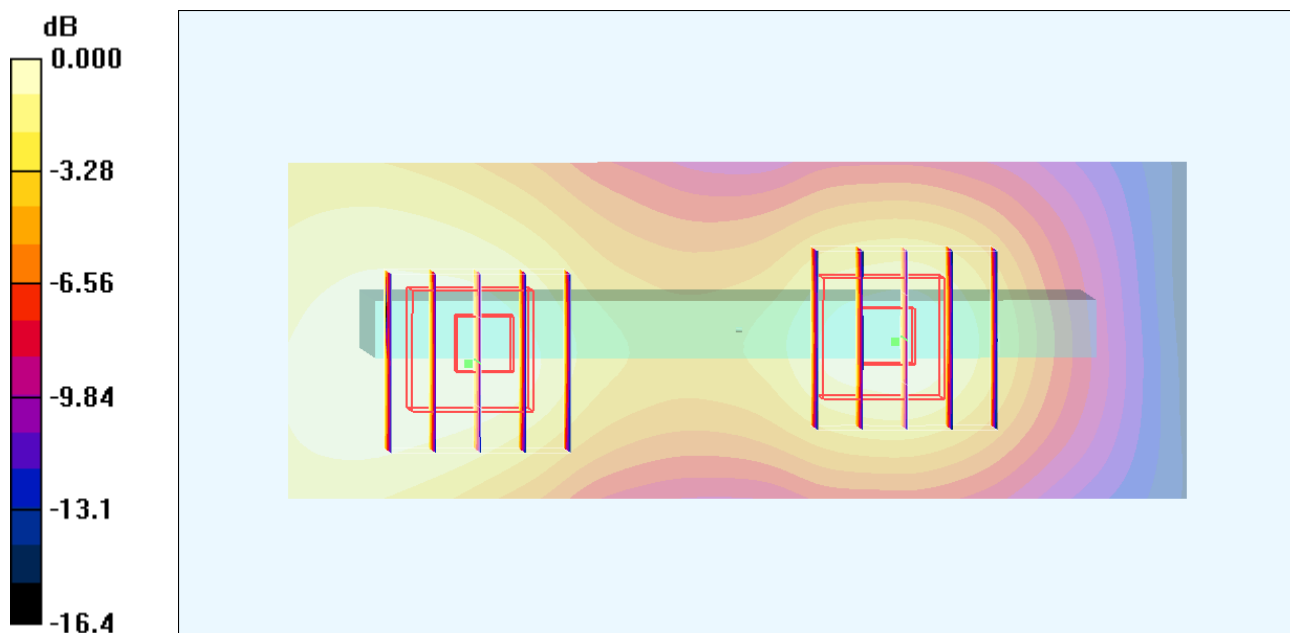

0 dB = 0.135mW/g

#15 GSM1900_GPRS12_Right Side_1cm_Ch810

DUT: 181934

Communication System: PCS; Frequency: 1909.8 MHz; Duty Cycle: 1:2

Medium: MSL_1900_111003 Medium parameters used: $f = 1910$ MHz; $\sigma = 1.55$ mho/m; $\epsilon_r = 51.9$; $\rho = 1000$ kg/m³

Ambient Temperature : 22.3 °C; Liquid Temperature : 21.3 °C

DASY4 Configuration:

- Probe: EX3DV4 - SN3697; ConvF(6.96, 6.96, 6.96); Calibrated: 2011-09-02
- Sensor-Surface: 4mm (Mechanical Surface Detection)
- Electronics: DAE4 Sn905; Calibrated: 2011-06-24
- Phantom: SAM_Right; Type: SAM; Serial: TP-1303
- Measurement SW: DASY4, V4.7 Build 80; Postprocessing SW: SEMCAD, V1.8 Build 186

Ch810/Area Scan (31x81x1): Measurement grid: dx=20mm, dy=20mm

Maximum value of SAR (interpolated) = 0.294 mW/g

Ch810/Zoom Scan (5x5x7)/Cube 0: Measurement grid: dx=8mm, dy=8mm, dz=5mm

Reference Value = 9.41 V/m; Power Drift = 0.026 dB

Peak SAR (extrapolated) = 0.456 W/kg

SAR(1 g) = 0.276 mW/g; SAR(10 g) = 0.158 mW/g

Maximum value of SAR (measured) = 0.300 mW/g

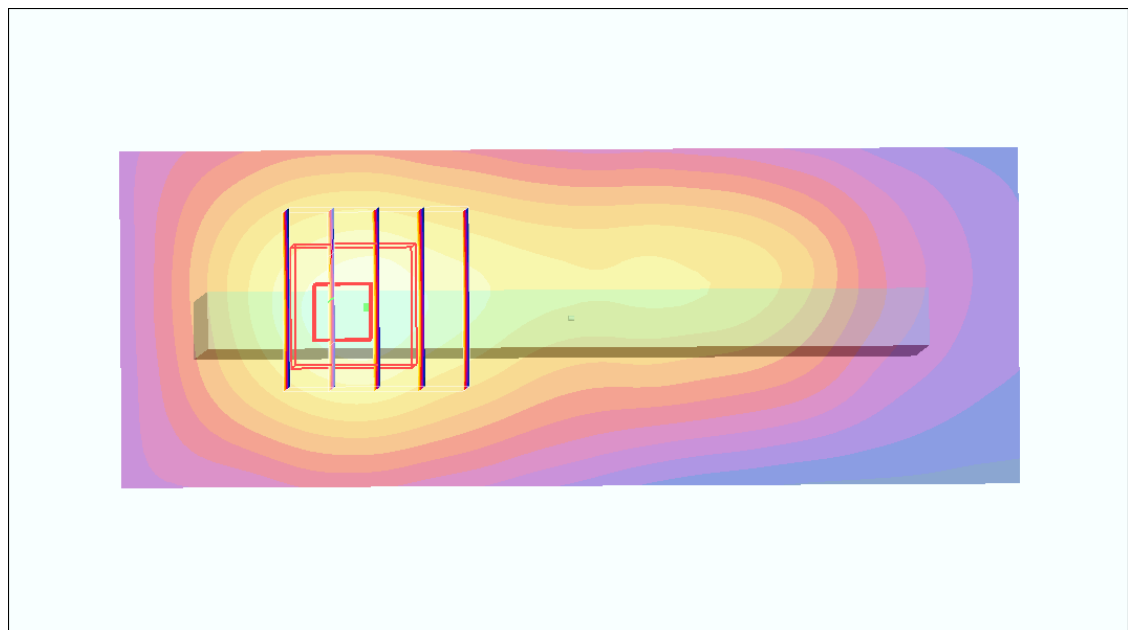
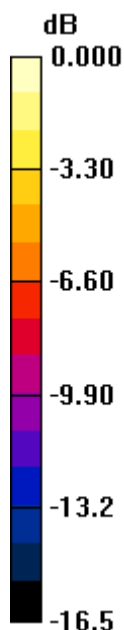

0 dB = 0.300mW/g

#16 GSM1900_GPRS12_Top Side_1cm_Ch810

DUT: 181934

Communication System: PCS; Frequency: 1909.8 MHz; Duty Cycle: 1:2

Medium: MSL_1900_111003 Medium parameters used: $f = 1910$ MHz; $\sigma = 1.55$ mho/m; $\epsilon_r = 51.9$; $\rho = 1000$ kg/m³

Ambient Temperature : 22.3 °C; Liquid Temperature : 21.3 °C

DASY4 Configuration:

- Probe: EX3DV4 - SN3697; ConvF(6.96, 6.96, 6.96); Calibrated: 2011-09-02
- Sensor-Surface: 4mm (Mechanical Surface Detection)
- Electronics: DAE4 Sn905; Calibrated: 2011-06-24
- Phantom: SAM_Right; Type: SAM; Serial: TP-1303
- Measurement SW: DASY4, V4.7 Build 80; Postprocessing SW: SEMCAD, V1.8 Build 186

Ch810/Area Scan (31x51x1): Measurement grid: dx=20mm, dy=20mm

Maximum value of SAR (interpolated) = 0.063 mW/g

Ch810/Zoom Scan (5x5x7)/Cube 0: Measurement grid: dx=8mm, dy=8mm, dz=5mm

Reference Value = 5.58 V/m; Power Drift = 0.004 dB

Peak SAR (extrapolated) = 0.078 W/kg

SAR(1 g) = 0.049 mW/g; SAR(10 g) = 0.029 mW/g

Maximum value of SAR (measured) = 0.055 mW/g

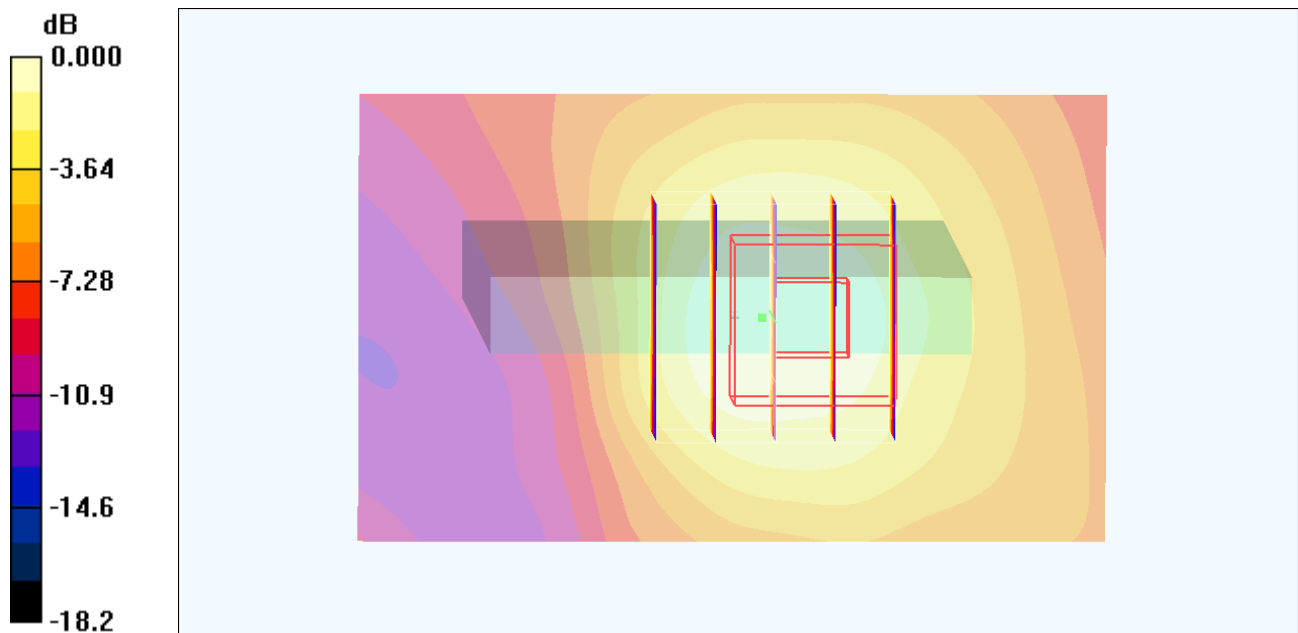

0 dB = 0.055mW/g

#17 GSM1900_GPRS12_Bottom Side_1cm_Ch810

DUT: 181934

Communication System: PCS; Frequency: 1909.8 MHz; Duty Cycle: 1:2

Medium: MSL_1900_111003 Medium parameters used: $f = 1910$ MHz; $\sigma = 1.55$ mho/m; $\epsilon_r = 51.9$; $\rho = 1000$ kg/m³

Ambient Temperature : 22.3 °C; Liquid Temperature : 21.3 °C

DASY4 Configuration:

- Probe: EX3DV4 - SN3697; ConvF(6.96, 6.96, 6.96); Calibrated: 2011-09-02
- Sensor-Surface: 4mm (Mechanical Surface Detection)
- Electronics: DAE4 Sn905; Calibrated: 2011-06-24
- Phantom: SAM_Right; Type: SAM; Serial: TP-1303
- Measurement SW: DASY4, V4.7 Build 80; Postprocessing SW: SEMCAD, V1.8 Build 186

Ch810/Area Scan (31x51x1): Measurement grid: dx=20mm, dy=20mm

Maximum value of SAR (interpolated) = 1.22 mW/g

Ch810/Zoom Scan (5x5x7)/Cube 0: Measurement grid: dx=8mm, dy=8mm, dz=5mm

Reference Value = 28.0 V/m; Power Drift = -0.009 dB

Peak SAR (extrapolated) = 1.95 W/kg

SAR(1 g) = 1.18 mW/g; SAR(10 g) = 0.636 mW/g

Maximum value of SAR (measured) = 1.34 mW/g

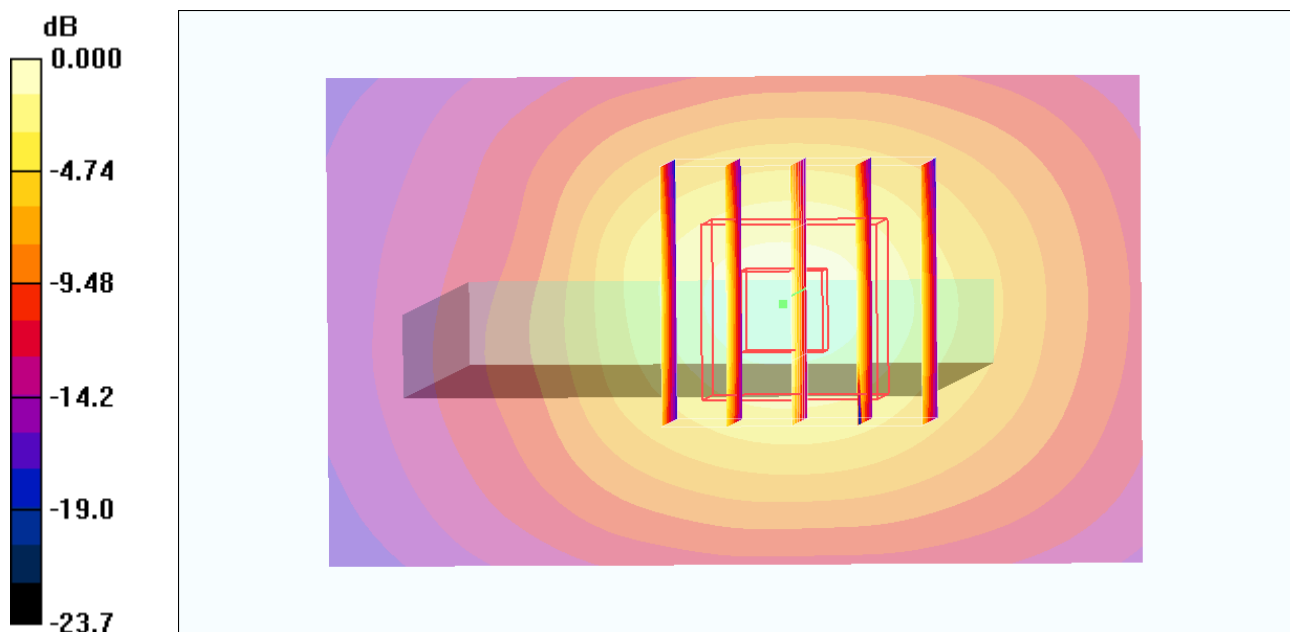

0 dB = 1.34mW/g

#17 GSM1900_GPRS12_Bottom Side_1cm_Ch810_2D

DUT: 181934

Communication System: PCS; Frequency: 1909.8 MHz; Duty Cycle: 1:2

Medium: MSL_1900_111003 Medium parameters used: $f = 1910$ MHz; $\sigma = 1.55$ mho/m; $\epsilon_r = 51.9$; $\rho = 1000$ kg/m³

Ambient Temperature : 22.3 °C ; Liquid Temperature : 21.3 °C

DASY4 Configuration:

- Probe: EX3DV4 - SN3697; ConvF(6.96, 6.96, 6.96); Calibrated: 2011-09-02
- Sensor-Surface: 4mm (Mechanical Surface Detection)
- Electronics: DAE4 Sn905; Calibrated: 2011-06-24
- Phantom: SAM_Right; Type: SAM; Serial: TP-1303
- Measurement SW: DASY4, V4.7 Build 80; Postprocessing SW: SEMCAD, V1.8 Build 186

Ch810/Area Scan (31x51x1): Measurement grid: dx=20mm, dy=20mm

Maximum value of SAR (interpolated) = 1.22 mW/g

Ch810/Zoom Scan (5x5x7)/Cube 0: Measurement grid: dx=8mm, dy=8mm, dz=5mm

Reference Value = 28.0 V/m; Power Drift = -0.009 dB

Peak SAR (extrapolated) = 1.95 W/kg

SAR(1 g) = 1.18 mW/g; SAR(10 g) = 0.636 mW/g

Maximum value of SAR (measured) = 1.34 mW/g

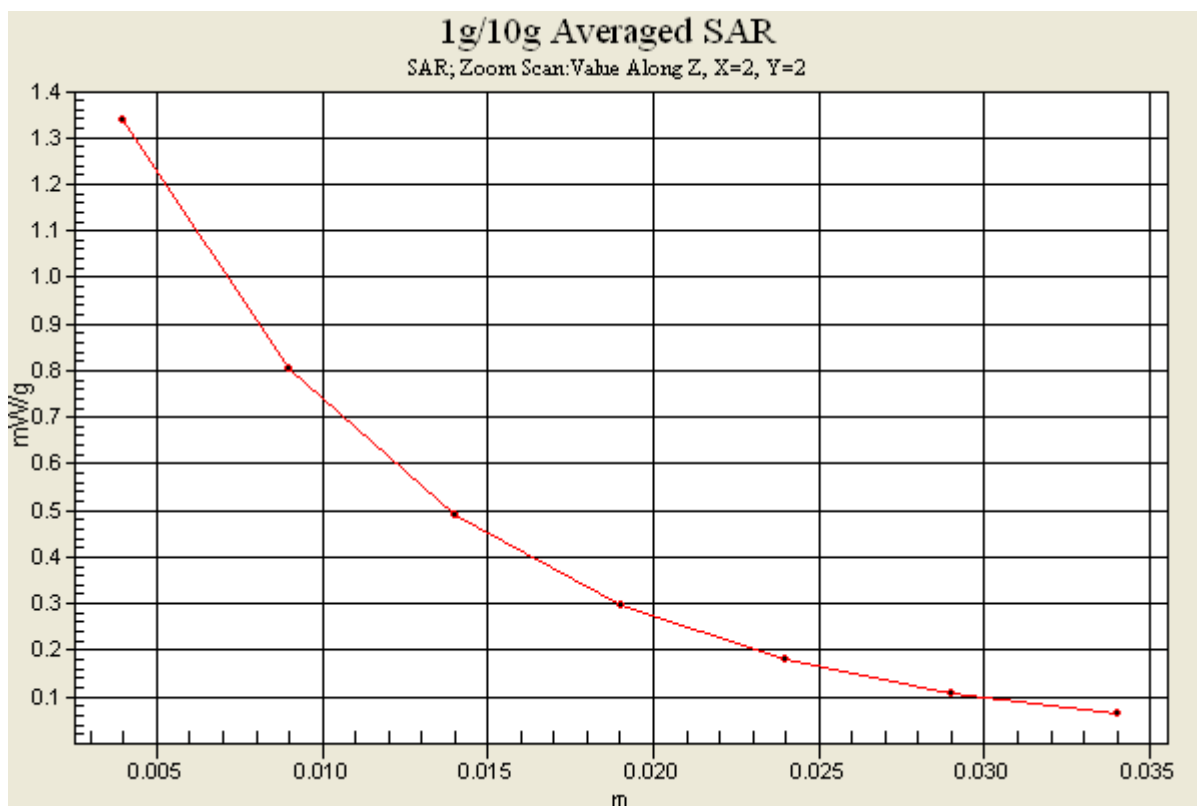

#23 GSM1900_GPRS12_Bottom Side_1cm_Ch512

DUT: 181934

Communication System: PCS; Frequency: 1850.2 MHz; Duty Cycle: 1:2

Medium: MSL_1900_111003 Medium parameters used: $f = 1850.2$ MHz; $\sigma = 1.5$ mho/m; $\epsilon_r = 52.2$; $\rho = 1000$ kg/m³

Ambient Temperature : 22.3 °C ; Liquid Temperature : 21.3 °C

DASY4 Configuration:

- Probe: EX3DV4 - SN3697; ConvF(6.96, 6.96, 6.96); Calibrated: 2011-09-02
- Sensor-Surface: 4mm (Mechanical Surface Detection)
- Electronics: DAE4 Sn905; Calibrated: 2011-06-24
- Phantom: SAM_Right; Type: SAM; Serial: TP-1303
- Measurement SW: DASY4, V4.7 Build 80; Postprocessing SW: SEMCAD, V1.8 Build 186

Ch512/Area Scan (31x51x1): Measurement grid: dx=20mm, dy=20mm

Maximum value of SAR (interpolated) = 0.799 mW/g

Ch512/Zoom Scan (5x5x7)/Cube 0: Measurement grid: dx=8mm, dy=8mm, dz=5mm

Reference Value = 24.2 V/m; Power Drift = -0.059 dB

Peak SAR (extrapolated) = 1.42 W/kg

SAR(1 g) = 0.833 mW/g; SAR(10 g) = 0.450 mW/g

Maximum value of SAR (measured) = 0.898 mW/g

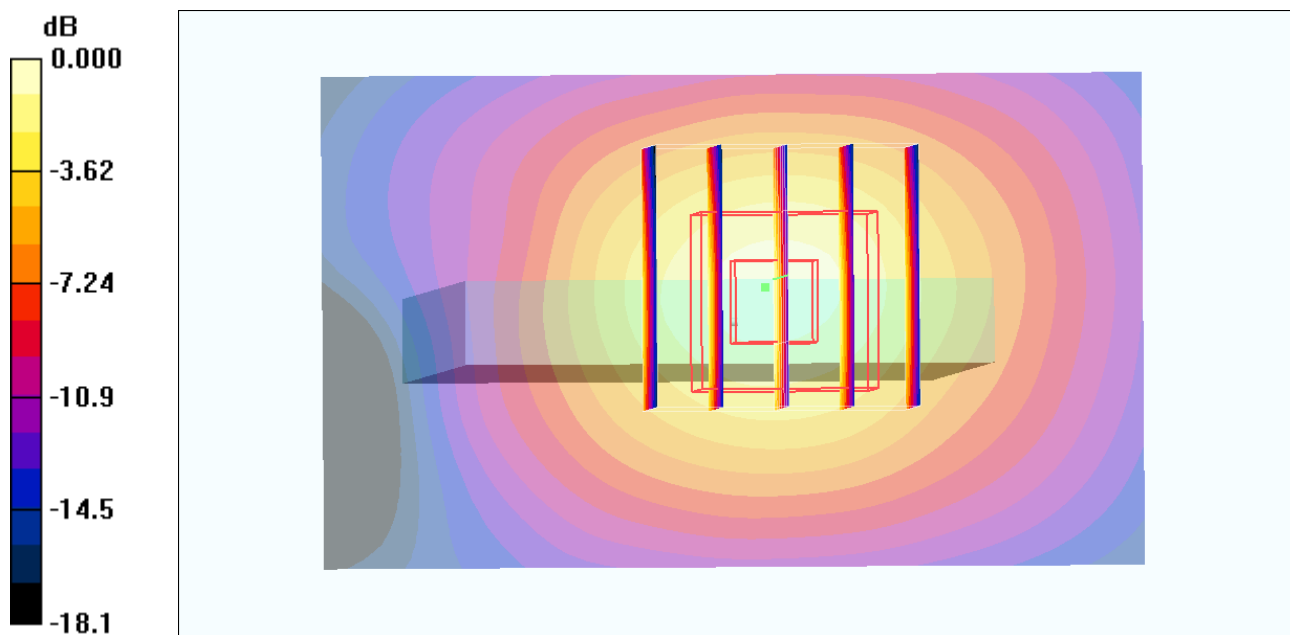

0 dB = 0.898mW/g

#24 GSM1900_GPRS12_Bottom Side_1cm_Ch661

DUT: 181934

Communication System: PCS; Frequency: 1880 MHz; Duty Cycle: 1:2

Medium: MSL_1900_111003 Medium parameters used: $f = 1880$ MHz; $\sigma = 1.53$ mho/m; $\epsilon_r = 52$; $\rho = 1000$ kg/m³

Ambient Temperature : 22.3 °C ; Liquid Temperature : 21.3 °C

DASY4 Configuration:

- Probe: EX3DV4 - SN3697; ConvF(6.96, 6.96, 6.96); Calibrated: 2011-09-02
- Sensor-Surface: 4mm (Mechanical Surface Detection)
- Electronics: DAE4 Sn905; Calibrated: 2011-06-24
- Phantom: SAM_Right; Type: SAM; Serial: TP-1303
- Measurement SW: DASY4, V4.7 Build 80; Postprocessing SW: SEMCAD, V1.8 Build 186

Ch661/Area Scan (31x51x1): Measurement grid: dx=20mm, dy=20mm

Maximum value of SAR (interpolated) = 1.14 mW/g

Ch661/Zoom Scan (5x5x7)/Cube 0: Measurement grid: dx=8mm, dy=8mm, dz=5mm

Reference Value = 27.9 V/m; Power Drift = -0.133 dB

Peak SAR (extrapolated) = 1.83 W/kg

SAR(1 g) = 1.08 mW/g; SAR(10 g) = 0.580 mW/g

Maximum value of SAR (measured) = 1.19 mW/g

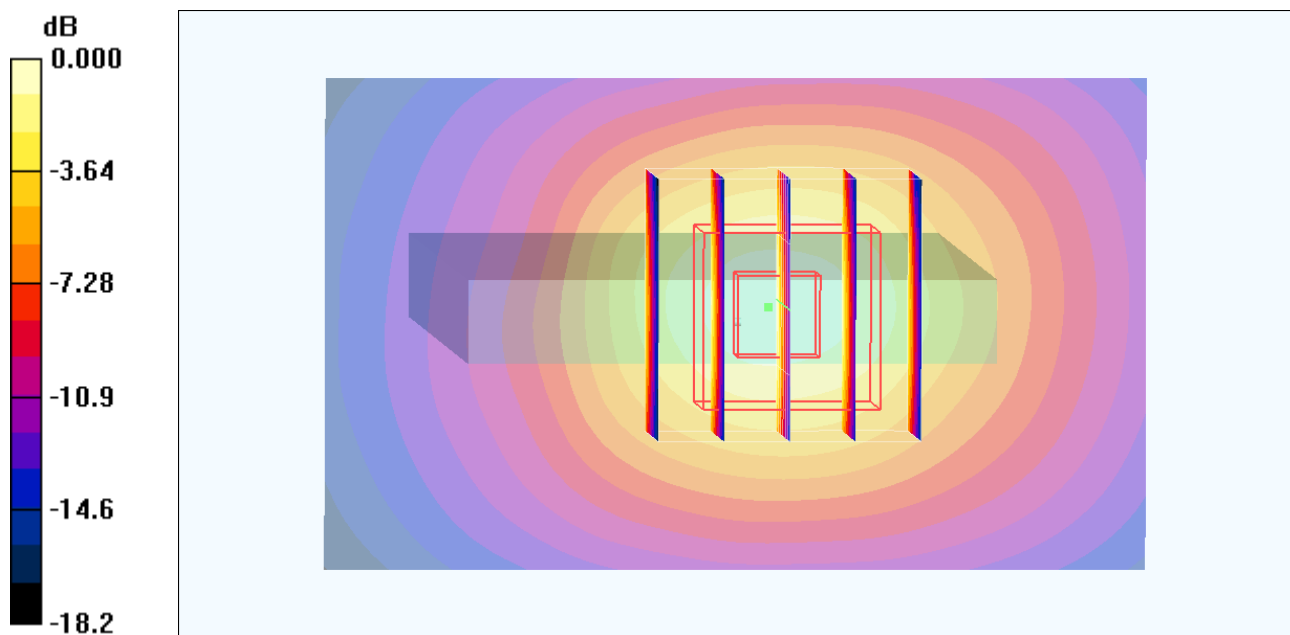

0 dB = 1.19mW/g

#12 GSM1900_GPRS12_Front_1cm_Ch810

DUT: 181934

Communication System: PCS; Frequency: 1909.8 MHz; Duty Cycle: 1:2

Medium: MSL_1900_111003 Medium parameters used: $f = 1910$ MHz; $\sigma = 1.55$ mho/m; $\epsilon_r = 51.9$; $\rho = 1000$ kg/m³

Ambient Temperature : 22.3 °C; Liquid Temperature : 21.3 °C

DASY4 Configuration:

- Probe: EX3DV4 - SN3697; ConvF(6.96, 6.96, 6.96); Calibrated: 2011-09-02
- Sensor-Surface: 4mm (Mechanical Surface Detection)
- Electronics: DAE4 Sn905; Calibrated: 2011-06-24
- Phantom: SAM_Right; Type: SAM; Serial: TP-1303
- Measurement SW: DASY4, V4.7 Build 80; Postprocessing SW: SEMCAD, V1.8 Build 186

Ch810/Area Scan (51x81x1): Measurement grid: dx=20mm, dy=20mm

Maximum value of SAR (interpolated) = 1.18 mW/g

Ch810/Zoom Scan (5x5x7)/Cube 0: Measurement grid: dx=8mm, dy=8mm, dz=5mm

Reference Value = 8.86 V/m; Power Drift = -0.086 dB

Peak SAR (extrapolated) = 1.65 W/kg

SAR(1 g) = 0.993 mW/g; SAR(10 g) = 0.554 mW/g

Maximum value of SAR (measured) = 1.04 mW/g

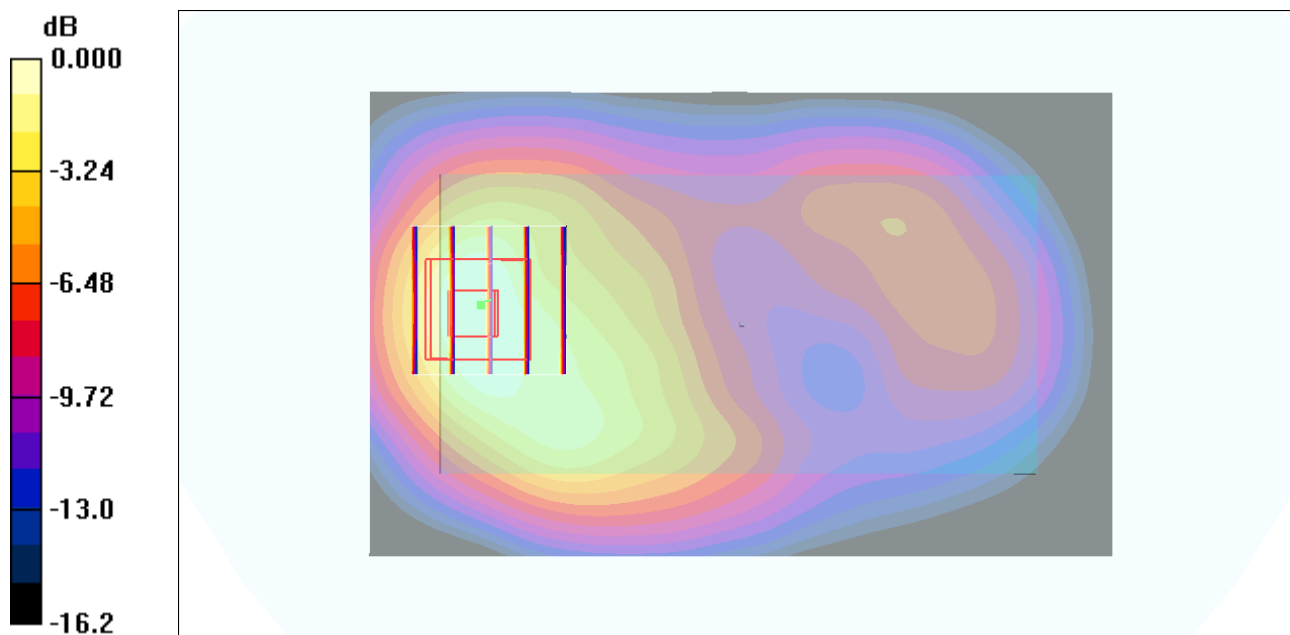

0 dB = 1.04mW/g

#19 GSM1900_GPRS12_Front_1cm_Ch512

DUT: 181934

Communication System: PCS; Frequency: 1850.2 MHz; Duty Cycle: 1:2

Medium: MSL_1900_111003 Medium parameters used: $f = 1850.2$ MHz; $\sigma = 1.5$ mho/m; $\epsilon_r = 52.2$; $\rho = 1000$ kg/m³

Ambient Temperature : 22.3 °C ; Liquid Temperature : 21.3 °C

DASY4 Configuration:

- Probe: EX3DV4 - SN3697; ConvF(6.96, 6.96, 6.96); Calibrated: 2011-09-02
- Sensor-Surface: 4mm (Mechanical Surface Detection)
- Electronics: DAE4 Sn905; Calibrated: 2011-06-24
- Phantom: SAM_Right; Type: SAM; Serial: TP-1303
- Measurement SW: DASY4, V4.7 Build 80; Postprocessing SW: SEMCAD, V1.8 Build 186

Ch512/Area Scan (51x81x1): Measurement grid: dx=20mm, dy=20mm

Maximum value of SAR (interpolated) = 0.746 mW/g

Ch512/Zoom Scan (5x5x7)/Cube 0: Measurement grid: dx=8mm, dy=8mm, dz=5mm

Reference Value = 7.34 V/m; Power Drift = -0.121 dB

Peak SAR (extrapolated) = 1.02 W/kg

SAR(1 g) = 0.627 mW/g; SAR(10 g) = 0.348 mW/g

Maximum value of SAR (measured) = 0.641 mW/g

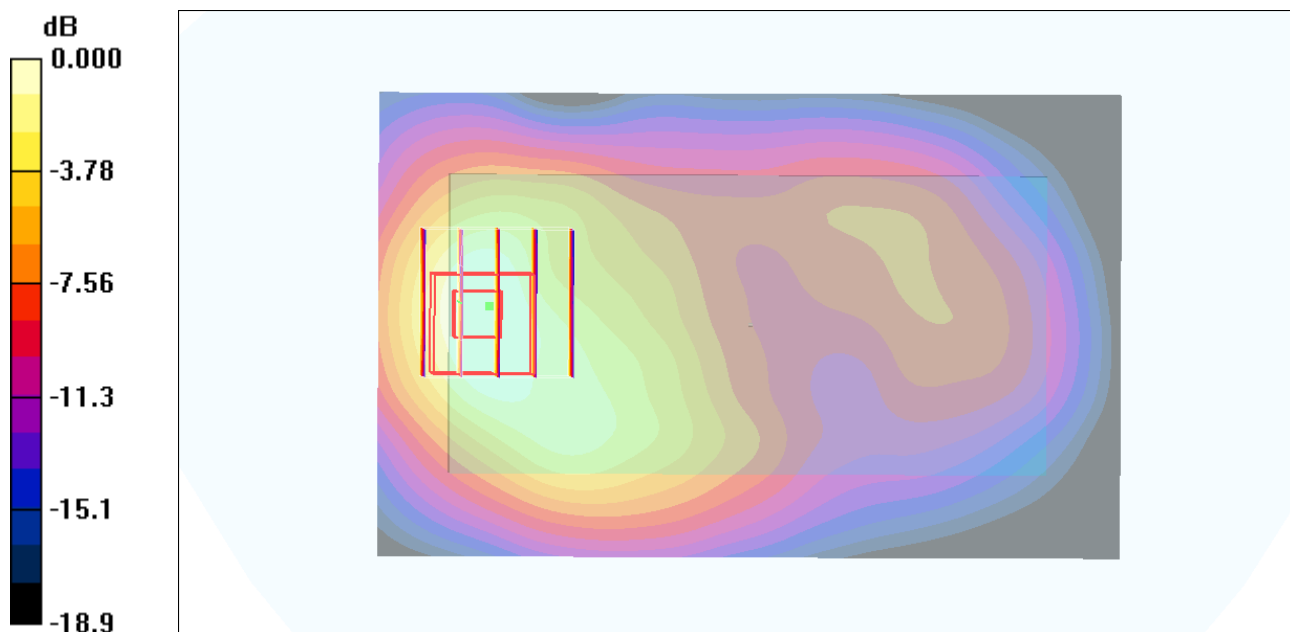

0 dB = 0.641mW/g

#20 GSM1900_GPRS12_Front_1cm_Ch661

DUT: 181934

Communication System: PCS; Frequency: 1880 MHz; Duty Cycle: 1:2

Medium: MSL_1900_111003 Medium parameters used: $f = 1880$ MHz; $\sigma = 1.53$ mho/m; $\epsilon_r = 52$; $\rho = 1000$ kg/m³

Ambient Temperature : 22.3 °C; Liquid Temperature : 21.3 °C

DASY4 Configuration:

- Probe: EX3DV4 - SN3697; ConvF(6.96, 6.96, 6.96); Calibrated: 2011-09-02
- Sensor-Surface: 4mm (Mechanical Surface Detection)
- Electronics: DAE4 Sn905; Calibrated: 2011-06-24
- Phantom: SAM_Right; Type: SAM; Serial: TP-1303
- Measurement SW: DASY4, V4.7 Build 80; Postprocessing SW: SEMCAD, V1.8 Build 186

Ch661/Area Scan (51x81x1): Measurement grid: dx=20mm, dy=20mm

Maximum value of SAR (interpolated) = 0.969 mW/g

Ch661/Zoom Scan (5x5x7)/Cube 0: Measurement grid: dx=8mm, dy=8mm, dz=5mm

Reference Value = 7.86 V/m; Power Drift = -0.089 dB

Peak SAR (extrapolated) = 1.29 W/kg

SAR(1 g) = 0.797 mW/g; SAR(10 g) = 0.449 mW/g

Maximum value of SAR (measured) = 0.831 mW/g

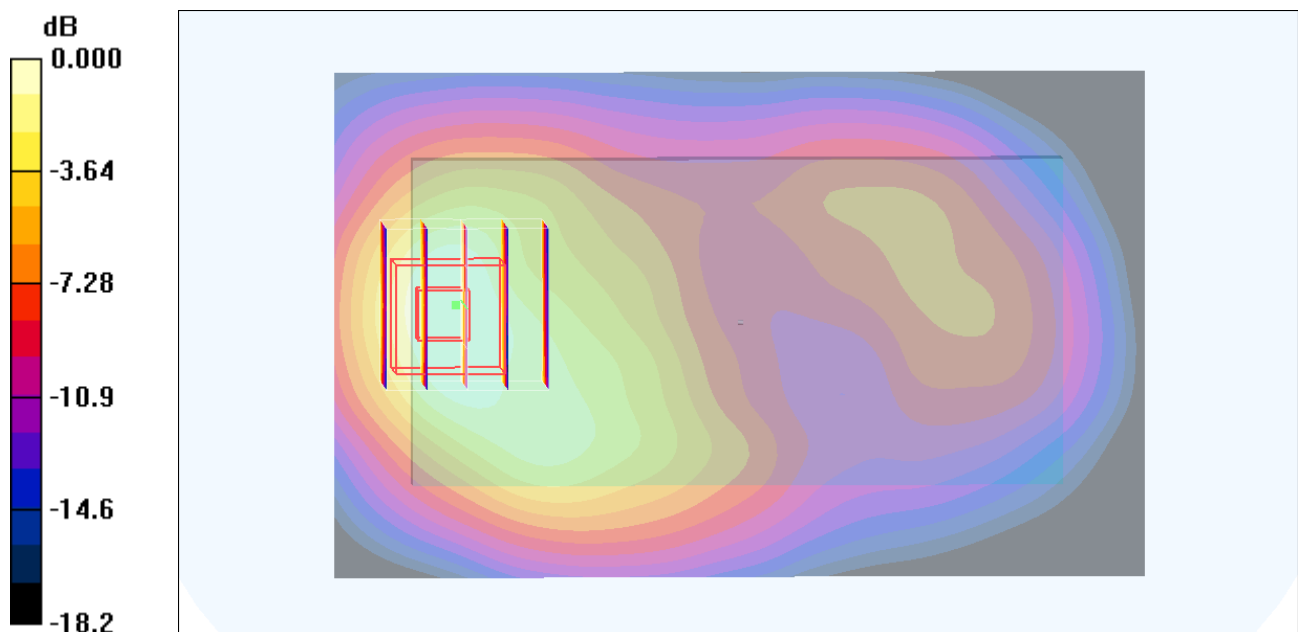

0 dB = 0.831mW/g

#13 GSM1900_GPRS12_Back_1cm_Ch810

DUT: 181934

Communication System: PCS; Frequency: 1909.8 MHz; Duty Cycle: 1:2

Medium: MSL_1900_111003 Medium parameters used: $f = 1910$ MHz; $\sigma = 1.55$ mho/m; $\epsilon_r = 51.9$; $\rho = 1000$ kg/m³

Ambient Temperature : 22.3 °C; Liquid Temperature : 21.3 °C

DASY4 Configuration:

- Probe: EX3DV4 - SN3697; ConvF(6.96, 6.96, 6.96); Calibrated: 2011-09-02
- Sensor-Surface: 4mm (Mechanical Surface Detection)
- Electronics: DAE4 Sn905; Calibrated: 2011-06-24
- Phantom: SAM_Right; Type: SAM; Serial: TP-1303
- Measurement SW: DASY4, V4.7 Build 80; Postprocessing SW: SEMCAD, V1.8 Build 186

Ch810/Area Scan (51x81x1): Measurement grid: dx=20mm, dy=20mm

Maximum value of SAR (interpolated) = 1.08 mW/g

Ch810/Zoom Scan (5x5x7)/Cube 0: Measurement grid: dx=8mm, dy=8mm, dz=5mm

Reference Value = 8.44 V/m; Power Drift = -0.096 dB

Peak SAR (extrapolated) = 1.44 W/kg

SAR(1 g) = 0.884 mW/g; SAR(10 g) = 0.501 mW/g

Maximum value of SAR (measured) = 0.909 mW/g

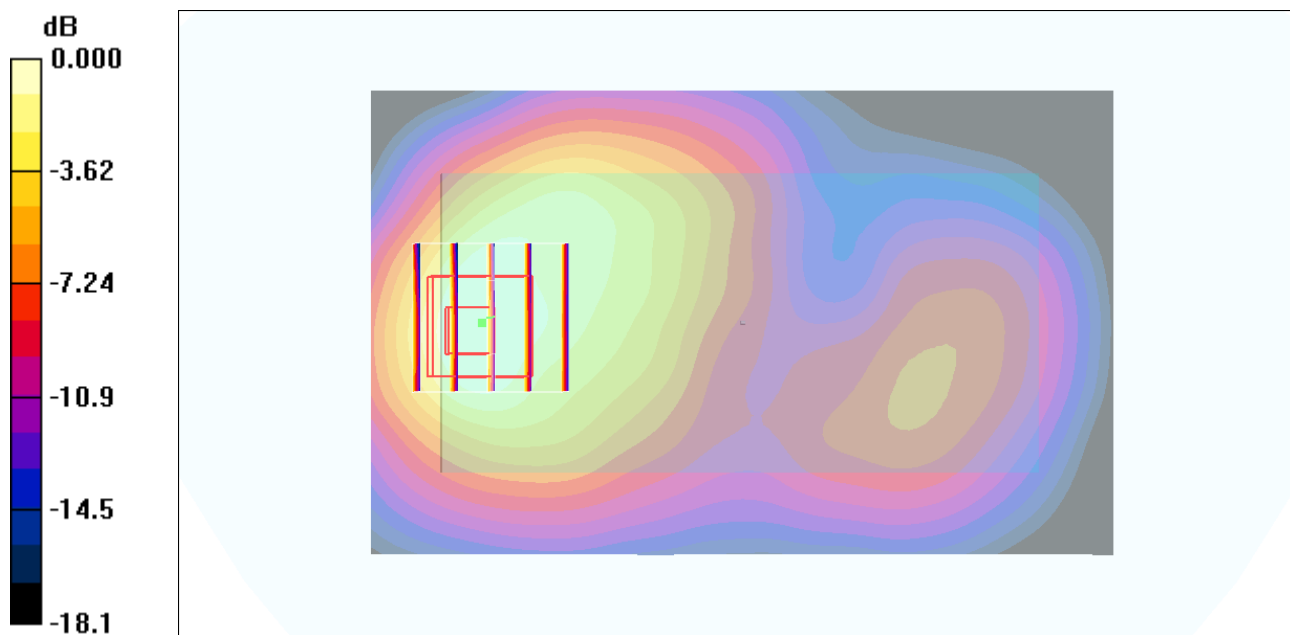

0 dB = 0.909mW/g

#21 GSM1900_GPRS12_Back_1cm_Ch512

DUT: 181934

Communication System: PCS; Frequency: 1850.2 MHz; Duty Cycle: 1:2

Medium: MSL_1900_111003 Medium parameters used: $f = 1850.2$ MHz; $\sigma = 1.5$ mho/m; $\epsilon_r = 52.2$; $\rho = 1000$ kg/m³

Ambient Temperature : 22.3 °C; Liquid Temperature : 21.3 °C

DASY4 Configuration:

- Probe: EX3DV4 - SN3697; ConvF(6.96, 6.96, 6.96); Calibrated: 2011-09-02
- Sensor-Surface: 4mm (Mechanical Surface Detection)
- Electronics: DAE4 Sn905; Calibrated: 2011-06-24
- Phantom: SAM_Right; Type: SAM; Serial: TP-1303
- Measurement SW: DASY4, V4.7 Build 80; Postprocessing SW: SEMCAD, V1.8 Build 186

Ch512/Area Scan (51x81x1): Measurement grid: dx=20mm, dy=20mm

Maximum value of SAR (interpolated) = 0.641 mW/g

Ch512/Zoom Scan (5x5x7)/Cube 0: Measurement grid: dx=8mm, dy=8mm, dz=5mm

Reference Value = 6.80 V/m; Power Drift = -0.123 dB

Peak SAR (extrapolated) = 0.844 W/kg

SAR(1 g) = 0.544 mW/g; SAR(10 g) = 0.303 mW/g

Maximum value of SAR (measured) = 0.587 mW/g

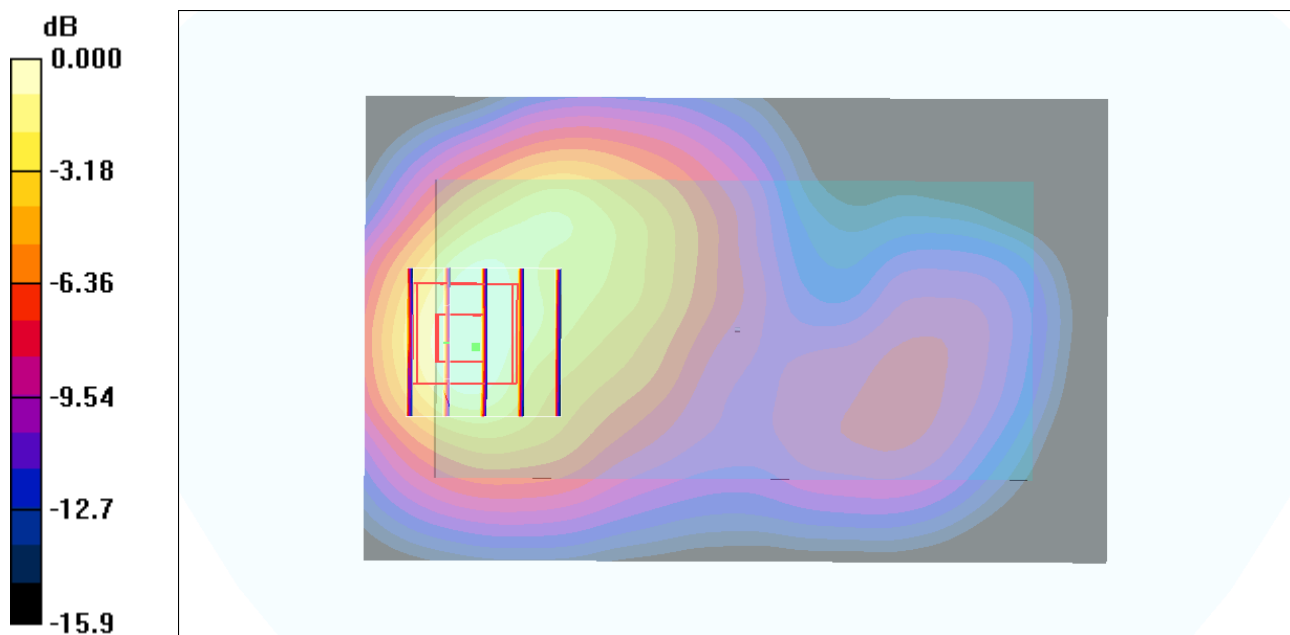

0 dB = 0.587mW/g

#22 GSM1900_GPRS12_Back_1cm_Ch661

DUT: 181934

Communication System: PCS; Frequency: 1880 MHz; Duty Cycle: 1:2

Medium: MSL_1900_111003 Medium parameters used: $f = 1880$ MHz; $\sigma = 1.53$ mho/m; $\epsilon_r = 52$; $\rho = 1000$ kg/m³

Ambient Temperature : 22.3 °C ; Liquid Temperature : 21.3 °C

DASY4 Configuration:

- Probe: EX3DV4 - SN3697; ConvF(6.96, 6.96, 6.96); Calibrated: 2011-09-02
- Sensor-Surface: 4mm (Mechanical Surface Detection)
- Electronics: DAE4 Sn905; Calibrated: 2011-06-24
- Phantom: SAM_Right; Type: SAM; Serial: TP-1303
- Measurement SW: DASY4, V4.7 Build 80; Postprocessing SW: SEMCAD, V1.8 Build 186

Ch661/Area Scan (51x81x1): Measurement grid: dx=20mm, dy=20mm

Maximum value of SAR (interpolated) = 0.825 mW/g

Ch661/Zoom Scan (5x5x7)/Cube 0: Measurement grid: dx=8mm, dy=8mm, dz=5mm

Reference Value = 7.33 V/m; Power Drift = -0.122 dB

Peak SAR (extrapolated) = 1.12 W/kg

SAR(1 g) = 0.682 mW/g; SAR(10 g) = 0.383 mW/g

Maximum value of SAR (measured) = 0.713 mW/g

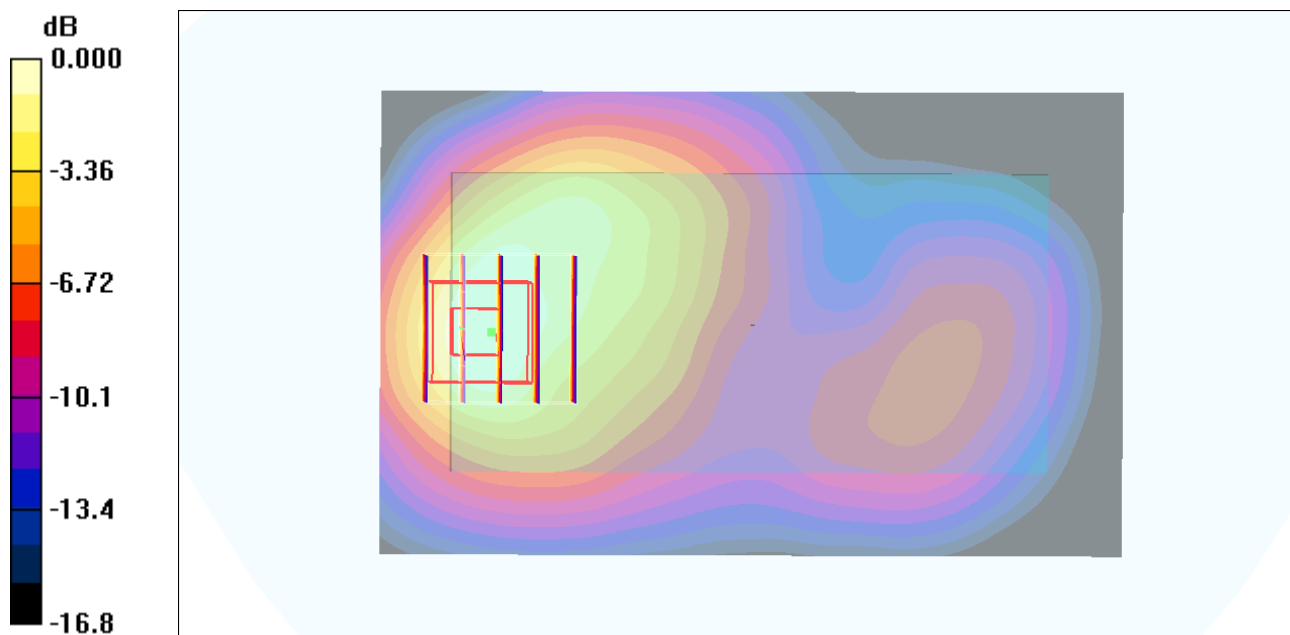

0 dB = 0.713mW/g

#18 GSM1900_GPRS12_Front_1cm_Ch810_Earphone

DUT: 181934

Communication System: PCS; Frequency: 1909.8 MHz; Duty Cycle: 1:2

Medium: MSL_1900_111003 Medium parameters used: $f = 1910$ MHz; $\sigma = 1.55$ mho/m; $\epsilon_r = 51.9$; $\rho = 1000$ kg/m³

Ambient Temperature : 22.3 °C ; Liquid Temperature : 21.3 °C

DASY4 Configuration:

- Probe: EX3DV4 - SN3697; ConvF(6.96, 6.96, 6.96); Calibrated: 2011-09-02
- Sensor-Surface: 4mm (Mechanical Surface Detection)
- Electronics: DAE4 Sn905; Calibrated: 2011-06-24
- Phantom: SAM_Right; Type: SAM; Serial: TP-1303
- Measurement SW: DASY4, V4.7 Build 80; Postprocessing SW: SEMCAD, V1.8 Build 186

Ch810/Area Scan (51x81x1): Measurement grid: dx=20mm, dy=20mm

Maximum value of SAR (interpolated) = 1.08 mW/g

Ch810/Zoom Scan (5x5x7)/Cube 0: Measurement grid: dx=8mm, dy=8mm, dz=5mm

Reference Value = 8.14 V/m; Power Drift = -0.031 dB

Peak SAR (extrapolated) = 1.45 W/kg

SAR(1 g) = 0.879 mW/g; SAR(10 g) = 0.501 mW/g

Maximum value of SAR (measured) = 0.927 mW/g

Ch810/Zoom Scan (5x5x7)/Cube 1: Measurement grid: dx=8mm, dy=8mm, dz=5mm

Reference Value = 8.14 V/m; Power Drift = -0.031 dB

Peak SAR (extrapolated) = 1.34 W/kg

SAR(1 g) = 0.740 mW/g; SAR(10 g) = 0.434 mW/g

Maximum value of SAR (measured) = 0.877 mW/g

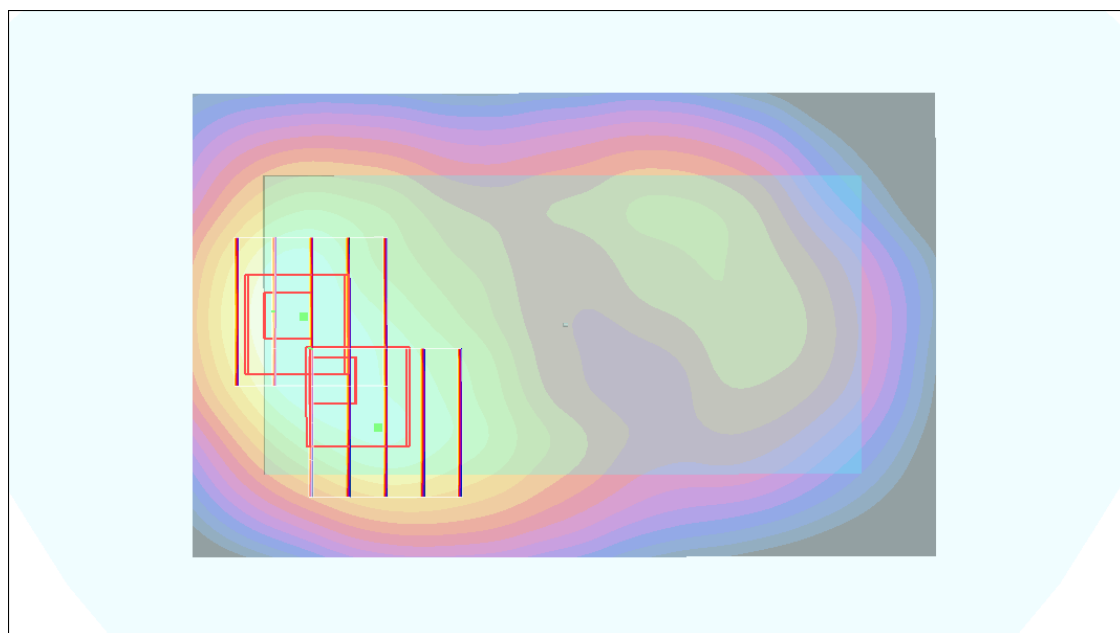
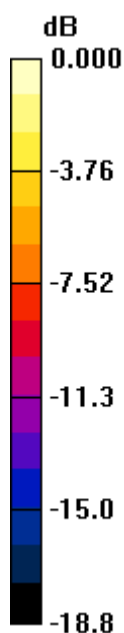

0 dB = 0.877mW/g

#40 GSM1900_GPRS12_Front_1cm_Ch512_Earphone

DUT: 181934

Communication System: PCS; Frequency: 1850.2 MHz; Duty Cycle: 1:2

Medium: MSL_1900_111014 Medium parameters used: $f = 1850.2$ MHz; $\sigma = 1.49$ mho/m; $\epsilon_r = 52.7$;

$\rho = 1000$ kg/m³

Ambient Temperature : 22.6 °C ; Liquid Temperature : 21.6 °C

DASY4 Configuration:

- Probe: ES3DV3 - SN3270; ConvF(4.64, 4.64, 4.64); Calibrated: 2011/9/12
- Sensor-Surface: 4mm (Mechanical Surface Detection)
- Electronics: DAE4 Sn905; Calibrated: 2011/6/24
- Phantom: SAM-Left; Type: QD 000 P40 C; Serial: TP-1478
- Measurement SW: DASY4, V4.7 Build 80; Postprocessing SW: SEMCAD, V1.8 Build 186

Ch512/Area Scan (51x81x1): Measurement grid: dx=20mm, dy=20mm

Maximum value of SAR (interpolated) = 0.605 mW/g

Ch512/Zoom Scan (5x5x7)/Cube 0: Measurement grid: dx=8mm, dy=8mm, dz=5mm

Reference Value = 6.40 V/m; Power Drift = -0.184 dB

Peak SAR (extrapolated) = 0.875 W/kg

SAR(1 g) = 0.526 mW/g; SAR(10 g) = 0.296 mW/g

Maximum value of SAR (measured) = 0.579 mW/g

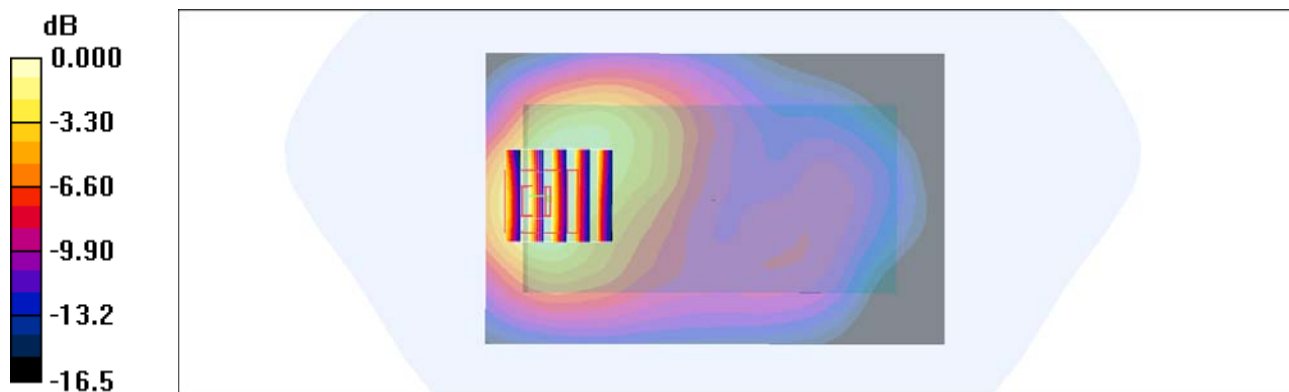

0 dB = 0.579mW/g

#41 GSM1900_GPRS12_Front_1cm_Ch661_Earphone

DUT: 181934

Communication System: PCS; Frequency: 1880 MHz; Duty Cycle: 1:2

Medium: MSL_1900_111014 Medium parameters used: $f = 1880$ MHz; $\sigma = 1.52$ mho/m; $\epsilon_r = 52.6$; $\rho = 1000$ kg/m³

Ambient Temperature : 22.6 °C ; Liquid Temperature : 21.6 °C

DASY4 Configuration:

- Probe: ES3DV3 - SN3270; ConvF(4.64, 4.64, 4.64); Calibrated: 2011/9/12
- Sensor-Surface: 4mm (Mechanical Surface Detection)
- Electronics: DAE4 Sn905; Calibrated: 2011/6/24
- Phantom: SAM-Left; Type: QD 000 P40 C; Serial: TP-1478
- Measurement SW: DASY4, V4.7 Build 80; Postprocessing SW: SEMCAD, V1.8 Build 186

Ch661/Area Scan (51x81x1): Measurement grid: dx=20mm, dy=20mm

Maximum value of SAR (interpolated) = 0.788 mW/g

Ch661/Zoom Scan (5x5x7)/Cube 0: Measurement grid: dx=8mm, dy=8mm, dz=5mm

Reference Value = 6.45 V/m; Power Drift = -0.086 dB

Peak SAR (extrapolated) = 1.17 W/kg

SAR(1 g) = 0.677 mW/g; SAR(10 g) = 0.382 mW/g

Maximum value of SAR (measured) = 0.721 mW/g

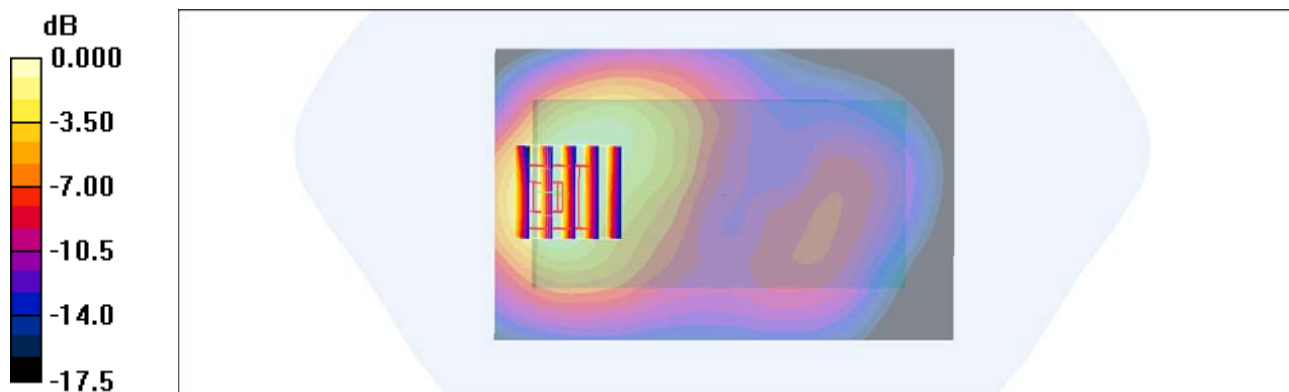

0 dB = 0.721mW/g

#05 802.11b_Front_1cm_Ch6

DUT: 181934

Communication System: 802.11b ; Frequency: 2437 MHz;Duty Cycle: 1:1

Medium: MSL_2450_110917 Medium parameters used: $f = 2437$ MHz; $\sigma = 1.95$ mho/m; $\epsilon_r = 53.8$; $\rho = 1000$ kg/m³

Ambient Temperature : 22.4 °C ; Liquid Temperature : 21.4 °C

DASY4 Configuration:

- Probe: EX3DV4 - SN3697; ConvF(6.73, 6.73, 6.73); Calibrated: 2011/9/2
- Sensor-Surface: 4mm (Mechanical Surface Detection)
- Electronics: DAE4 Sn1279; Calibrated: 2011/6/17
- Phantom: ELI 4.0_Front; Type: QDOVA001BB; Serial: 1026
- Measurement SW: DASY4, V4.7 Build 80; Postprocessing SW: SEMCAD, V1.8 Build 186

Ch6/Area Scan (61x81x1): Measurement grid: dx=20mm, dy=20mm

Maximum value of SAR (interpolated) = 0.023 mW/g

Ch6/Zoom Scan (5x5x7)/Cube 0: Measurement grid: dx=8mm, dy=8mm, dz=5mm

Reference Value = 2.38 V/m; Power Drift = -0.02 dB

Peak SAR (extrapolated) = 0.038 W/kg

SAR(1 g) = 0.020 mW/g; SAR(10 g) = 0.00971 mW/g

Maximum value of SAR (measured) = 0.023 mW/g

Ch6/Zoom Scan (5x5x7)/Cube 1: Measurement grid: dx=8mm, dy=8mm, dz=5mm

Reference Value = 2.38 V/m; Power Drift = -0.02 dB

Peak SAR (extrapolated) = 0.054 W/kg

SAR(1 g) = 0.013 mW/g; SAR(10 g) = 0.00597 mW/g

Maximum value of SAR (measured) = 0.016 mW/g

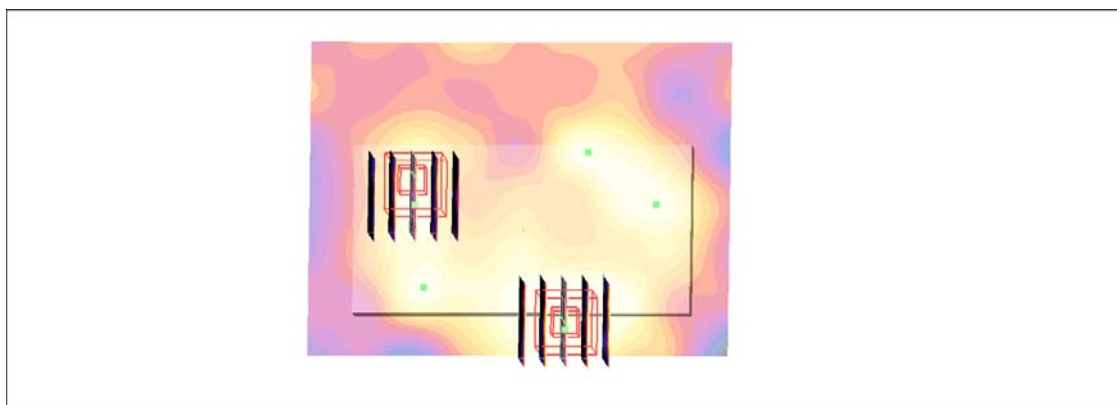
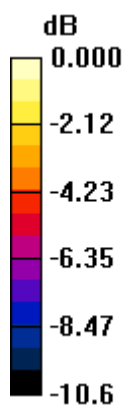

0 dB = 0.016mW/g

#06 802.11b_Back_1cm_Ch6

DUT: 181934

Communication System: 802.11b ; Frequency: 2437 MHz;Duty Cycle: 1:1

Medium: MSL_2450_110917 Medium parameters used: $f = 2437$ MHz; $\sigma = 1.95$ mho/m; $\epsilon_r = 53.8$; $\rho = 1000$ kg/m³

Ambient Temperature : 22.4 °C ; Liquid Temperature : 21.4 °C

DASY4 Configuration:

- Probe: EX3DV4 - SN3697; ConvF(6.73, 6.73, 6.73); Calibrated: 2011/9/2
- Sensor-Surface: 4mm (Mechanical Surface Detection)
- Electronics: DAE4 Sn1279; Calibrated: 2011/6/17
- Phantom: ELI 4.0_Front; Type: QDOVA001BB; Serial: 1026
- Measurement SW: DASY4, V4.7 Build 80; Postprocessing SW: SEMCAD, V1.8 Build 186

Ch6/Area Scan (51x81x1): Measurement grid: dx=20mm, dy=20mm

Maximum value of SAR (interpolated) = 0.097 mW/g

Ch6/Zoom Scan (5x5x7)/Cube 0: Measurement grid: dx=8mm, dy=8mm, dz=5mm

Reference Value = 5.05 V/m; Power Drift = 0.076 dB

Peak SAR (extrapolated) = 0.178 W/kg

SAR(1 g) = 0.080 mW/g; SAR(10 g) = 0.038 mW/g

Maximum value of SAR (measured) = 0.086 mW/g

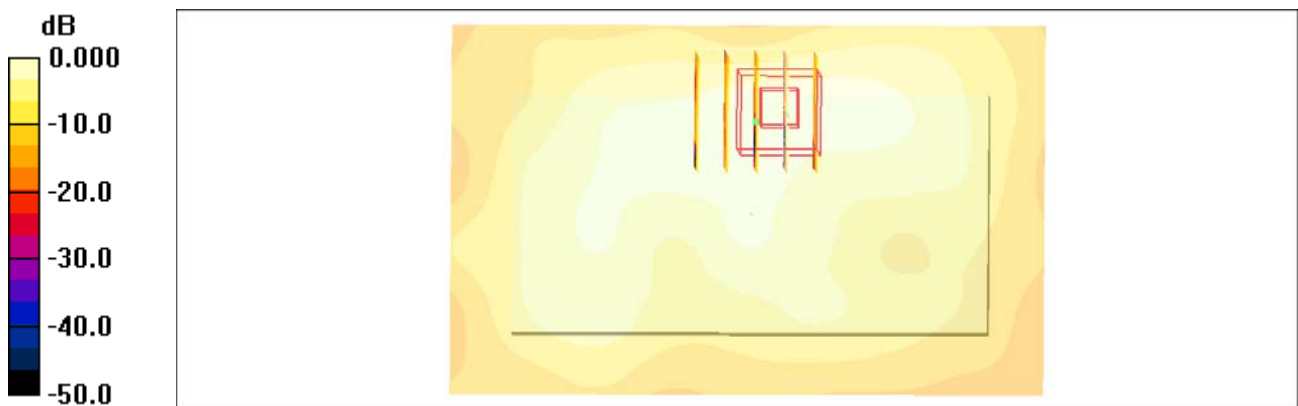

0 dB = 0.086mW/g

#07 802.11b_Left Side_1cm_Ch6

DUT: 181934

Communication System: 802.11b ; Frequency: 2437 MHz;Duty Cycle: 1:1

Medium: MSL_2450_110917 Medium parameters used: $f = 2437$ MHz; $\sigma = 1.95$ mho/m; $\epsilon_r = 53.8$; $\rho = 1000$ kg/m³

Ambient Temperature : 22.4 °C ; Liquid Temperature : 21.4 °C

DASY4 Configuration:

- Probe: EX3DV4 - SN3697; ConvF(6.73, 6.73, 6.73); Calibrated: 2011/9/2
- Sensor-Surface: 4mm (Mechanical Surface Detection)
- Electronics: DAE4 Sn1279; Calibrated: 2011/6/17
- Phantom: ELI 4.0_Front; Type: QDOVA001BB; Serial: 1026
- Measurement SW: DASY4, V4.7 Build 80; Postprocessing SW: SEMCAD, V1.8 Build 186

Ch6/Area Scan (31x81x1): Measurement grid: dx=20mm, dy=20mm

Maximum value of SAR (interpolated) = 0.018 mW/g

Ch6/Zoom Scan (5x5x7)/Cube 1: Measurement grid: dx=8mm, dy=8mm, dz=5mm

Reference Value = 2.04 V/m; Power Drift = -0.06 dB

Peak SAR (extrapolated) = 0.024 W/kg

SAR(1 g) = 0.00998 mW/g; SAR(10 g) = 0.0047 mW/g

Maximum value of SAR (measured) = 0.012 mW/g

Ch6/Zoom Scan (5x5x7)/Cube 0: Measurement grid: dx=8mm, dy=8mm, dz=5mm

Reference Value = 2.04 V/m; Power Drift = -0.06 dB

Peak SAR (extrapolated) = 0.013 W/kg

SAR(1 g) = 0.00881 mW/g; SAR(10 g) = 0.00446 mW/g

Maximum value of SAR (measured) = 0.011 mW/g

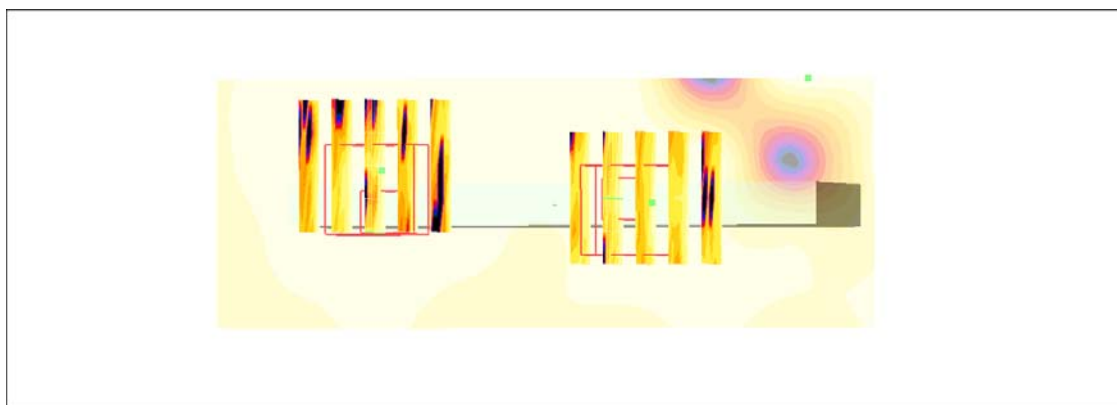
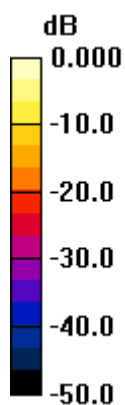

0 dB = 0.011mW/g

#08 802.11b_Right Side_1cm_Ch6

DUT: 181934

Communication System: 802.11b ; Frequency: 2437 MHz;Duty Cycle: 1:1

Medium: MSL_2450_110917 Medium parameters used: $f = 2437$ MHz; $\sigma = 1.95$ mho/m; $\epsilon_r = 53.8$; $\rho = 1000$ kg/m³

Ambient Temperature : 22.4 °C ; Liquid Temperature : 21.4 °C

DASY4 Configuration:

- Probe: EX3DV4 - SN3697; ConvF(6.73, 6.73, 6.73); Calibrated: 2011/9/2
- Sensor-Surface: 4mm (Mechanical Surface Detection)
- Electronics: DAE4 Sn1279; Calibrated: 2011/6/17
- Phantom: ELI 4.0_Front; Type: QDOVA001BB; Serial: 1026
- Measurement SW: DASY4, V4.7 Build 80; Postprocessing SW: SEMCAD, V1.8 Build 186

Ch6/Area Scan (31x81x1): Measurement grid: dx=20mm, dy=20mm

Maximum value of SAR (interpolated) = 0.058 mW/g

Ch6/Zoom Scan (5x5x7)/Cube 1: Measurement grid: dx=8mm, dy=8mm, dz=5mm

Reference Value = 4.48 V/m; Power Drift = -0.092 dB

Peak SAR (extrapolated) = 0.114 W/kg

SAR(1 g) = 0.057 mW/g; SAR(10 g) = 0.027 mW/g

Maximum value of SAR (measured) = 0.065 mW/g

Ch6/Zoom Scan (5x5x7)/Cube 0: Measurement grid: dx=8mm, dy=8mm, dz=5mm

Reference Value = 4.48 V/m; Power Drift = -0.092 dB

Peak SAR (extrapolated) = 0.100 W/kg

SAR(1 g) = 0.053 mW/g; SAR(10 g) = 0.028 mW/g

Maximum value of SAR (measured) = 0.056 mW/g

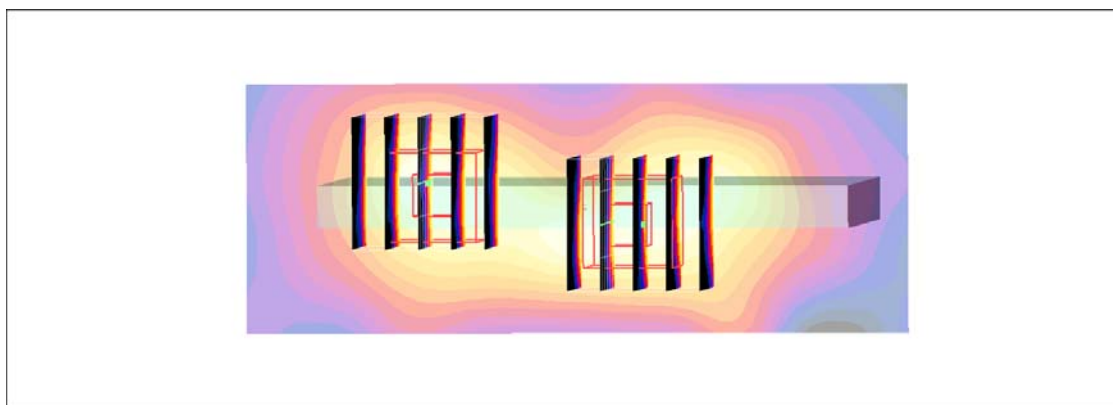
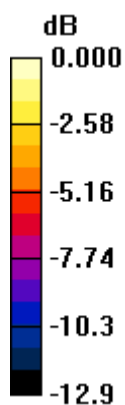

0 dB = 0.056mW/g

#09 802.11b_Top Side_1cm_Ch6

DUT: 181934

Communication System: 802.11b ; Frequency: 2437 MHz;Duty Cycle: 1:1

Medium: MSL_2450_110917 Medium parameters used: $f = 2437$ MHz; $\sigma = 1.95$ mho/m; $\epsilon_r = 53.8$; $\rho = 1000$ kg/m³

Ambient Temperature : 22.4 °C ; Liquid Temperature : 21.4 °C

DASY4 Configuration:

- Probe: EX3DV4 - SN3697; ConvF(6.73, 6.73, 6.73); Calibrated: 2011/9/2
- Sensor-Surface: 4mm (Mechanical Surface Detection)
- Electronics: DAE4 Sn1279; Calibrated: 2011/6/17
- Phantom: ELI 4.0_Front; Type: QDOVA001BB; Serial: 1026
- Measurement SW: DASY4, V4.7 Build 80; Postprocessing SW: SEMCAD, V1.8 Build 186

Ch6/Area Scan (41x71x1): Measurement grid: dx=20mm, dy=20mm

Maximum value of SAR (interpolated) = 0.011 mW/g

Ch6/Zoom Scan (5x5x7)/Cube 0: Measurement grid: dx=8mm, dy=8mm, dz=5mm

Reference Value = 2.18 V/m; Power Drift = -0.14 dB

Peak SAR (extrapolated) = 0.024 W/kg

SAR(1 g) = 0.00778 mW/g; SAR(10 g) = 0.00357 mW/g

Maximum value of SAR (measured) = 0.009 mW/g

Ch6/Zoom Scan (5x5x7)/Cube 1: Measurement grid: dx=8mm, dy=8mm, dz=5mm

Reference Value = 2.18 V/m; Power Drift = -0.14 dB

Peak SAR (extrapolated) = 0.026 W/kg

SAR(1 g) = 0.00636 mW/g; SAR(10 g) = 0.00303 mW/g

Maximum value of SAR (measured) = 0.007 mW/g

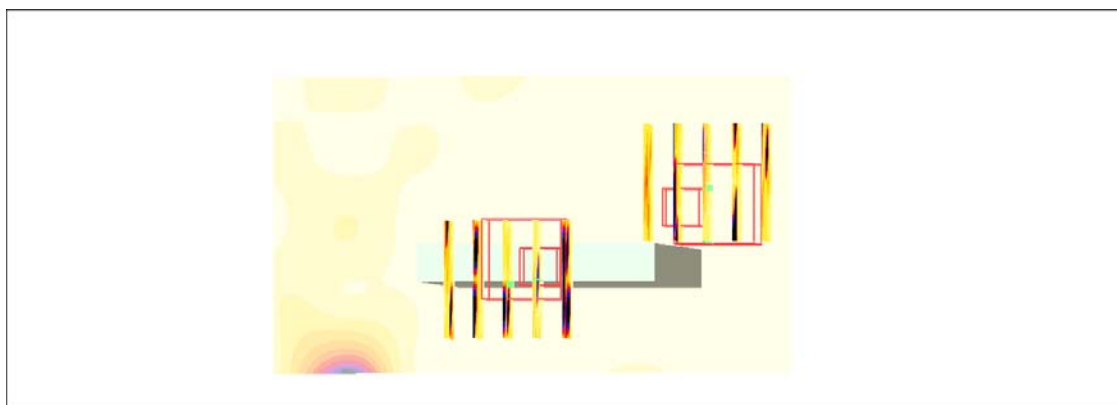
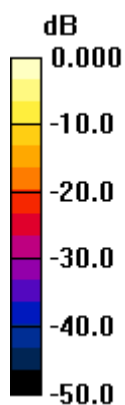

0 dB = 0.007mW/g

#10 802.11b_Down Side_1cm_Ch6

DUT: 181934

Communication System: 802.11b ; Frequency: 2437 MHz;Duty Cycle: 1:1

Medium: MSL_2450_110917 Medium parameters used: $f = 2437$ MHz; $\sigma = 1.95$ mho/m; $\epsilon_r = 53.8$; ρ

$= 1000$ kg/m³

Ambient Temperature : 22.4 °C ; Liquid Temperature : 21.4 °C

DASY4 Configuration:

- Probe: EX3DV4 - SN3697; ConvF(6.73, 6.73, 6.73); Calibrated: 2011/9/2
- Sensor-Surface: 4mm (Mechanical Surface Detection)
- Electronics: DAE4 Sn1279; Calibrated: 2011/6/17
- Phantom: ELI 4.0_Front; Type: QDOVA001BB; Serial: 1026
- Measurement SW: DASY4, V4.7 Build 80; Postprocessing SW: SEMCAD, V1.8 Build 186

Ch6/Area Scan (51x71x1): Measurement grid: dx=20mm, dy=20mm

Maximum value of SAR (interpolated) = 0.013 mW/g

Ch6/Zoom Scan (5x5x7)/Cube 0: Measurement grid: dx=8mm, dy=8mm, dz=5mm

Reference Value = 2.19 V/m; Power Drift = -0.036 dB

Peak SAR (extrapolated) = 0.018 W/kg

SAR(1 g) = 0.00909 mW/g; SAR(10 g) = 0.00442 mW/g

Maximum value of SAR (measured) = 0.010 mW/g

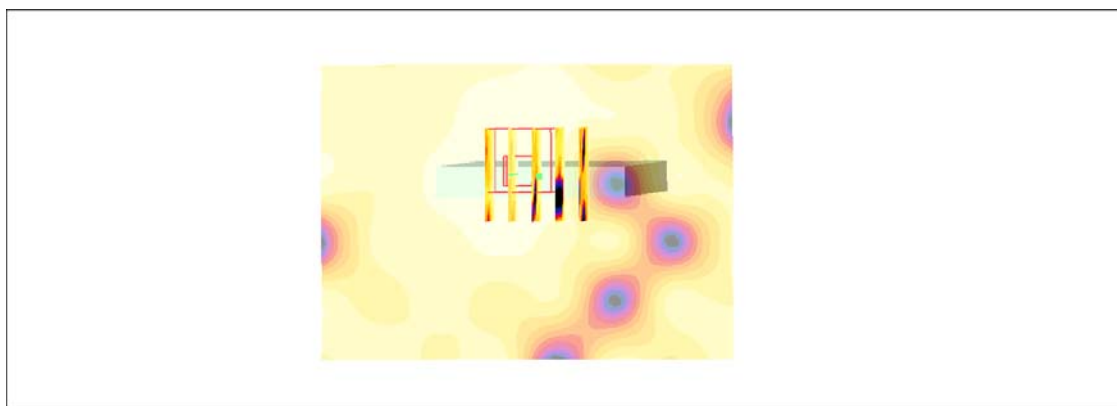
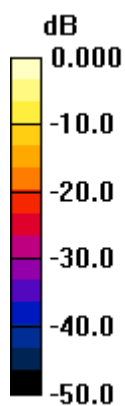

0 dB = 0.010mW/g

#11 802.11b_Back_1cm_Ch6_Earphone

DUT: 181934

Communication System: 802.11b ; Frequency: 2437 MHz;Duty Cycle: 1:1

Medium: MSL_2450_110917 Medium parameters used: $f = 2437$ MHz; $\sigma = 1.95$ mho/m; $\epsilon_r = 53.8$; ρ

$= 1000$ kg/m³

Ambient Temperature : 22.4 °C ; Liquid Temperature : 21.4 °C

DASY4 Configuration:

- Probe: EX3DV4 - SN3697; ConvF(6.73, 6.73, 6.73); Calibrated: 2011/9/2
- Sensor-Surface: 4mm (Mechanical Surface Detection)
- Electronics: DAE4 Sn1279; Calibrated: 2011/6/17
- Phantom: ELI 4.0_Front; Type: QDOVA001BB; Serial: 1026
- Measurement SW: DASY4, V4.7 Build 80; Postprocessing SW: SEMCAD, V1.8 Build 186

Ch6/Area Scan (51x81x1): Measurement grid: dx=20mm, dy=20mm

Maximum value of SAR (interpolated) = 0.125 mW/g

Ch6/Zoom Scan (5x5x7)/Cube 0: Measurement grid: dx=8mm, dy=8mm, dz=5mm

Reference Value = 5.85 V/m; Power Drift = -0.093 dB

Peak SAR (extrapolated) = 0.202 W/kg

SAR(1 g) = 0.093 mW/g; SAR(10 g) = 0.045 mW/g

Maximum value of SAR (measured) = 0.102 mW/g

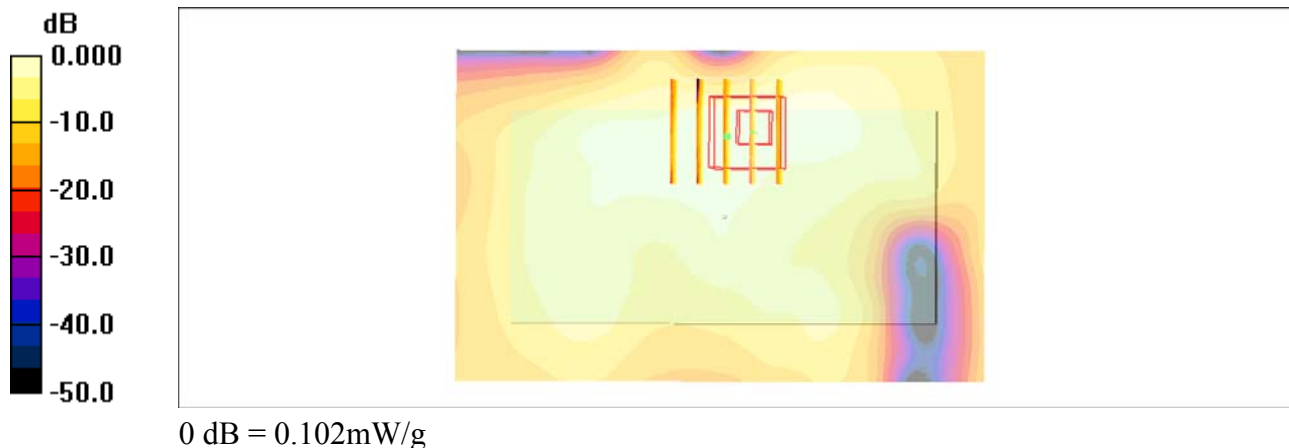

#11 802.11b_Back_1cm_Ch6_Earphone_2D

DUT: 181934

Communication System: 802.11b ; Frequency: 2437 MHz;Duty Cycle: 1:1

Medium: MSL_2450_110917 Medium parameters used: $f = 2437$ MHz; $\sigma = 1.95$ mho/m; $\epsilon_r = 53.8$;

$\rho = 1000$ kg/m³

Ambient Temperature : 22.4 °C ; Liquid Temperature : 21.4 °C

DASY4 Configuration:

- Probe: EX3DV4 - SN3697; ConvF(6.73, 6.73, 6.73); Calibrated: 2011/9/2
- Sensor-Surface: 4mm (Mechanical Surface Detection)
- Electronics: DAE4 Sn1279; Calibrated: 2011/6/17
- Phantom: ELI 4.0_Front; Type: QDOVA001BB; Serial: 1026
- Measurement SW: DASY4, V4.7 Build 80; Postprocessing SW: SEMCAD, V1.8 Build 186

Ch6/Area Scan (51x81x1): Measurement grid: dx=20mm, dy=20mm

Maximum value of SAR (interpolated) = 0.125 mW/g

Ch6/Zoom Scan (5x5x7)/Cube 0: Measurement grid: dx=8mm, dy=8mm, dz=5mm

Reference Value = 5.85 V/m; Power Drift = -0.093 dB

Peak SAR (extrapolated) = 0.202 W/kg

SAR(1 g) = 0.093 mW/g; SAR(10 g) = 0.045 mW/g

Maximum value of SAR (measured) = 0.102 mW/g

