

System Check_Head_835MHz_111004

DUT: Dipole 835 MHz

Communication System: CW; Frequency: 835 MHz; Duty Cycle: 1:1

Medium: HSL_850_111004 Medium parameters used: $f = 835 \text{ MHz}$; $\sigma = 0.895 \text{ mho/m}$; $\epsilon_r = 41.666$; $\rho = 1000 \text{ kg/m}^3$

Ambient Temperature : 22.3 °C ; Liquid Temperature : 21.3 °C

DASY5 Configuration:

- Probe: ES3DV3 - SN3270; ConvF(6.04, 6.04, 6.04); Calibrated: 2011/9/12
- Sensor-Surface: 4mm (Mechanical Surface Detection)
- Electronics: DAE3 Sn495; Calibrated: 2011/4/28
- Phantom: SAM Left; Type: QD000P40CD; Serial: TP:1542
- Measurement SW: DASY52, Version 52.6 (2); SEMCAD X Version 14.4.5 (3634)

Pin=250mW/Area Scan (61x61x1): Measurement grid: dx=15mm, dy=15mm

Maximum value of SAR (interpolated) = 2.576 mW/g

Pin=250mW/Zoom Scan (7x7x7)/Cube 0: Measurement grid: dx=5mm, dy=5mm, dz=5mm

Reference Value = 54.000 V/m; Power Drift = 0.02 dB

Peak SAR (extrapolated) = 3.642 W/kg

SAR(1 g) = 2.39 mW/g; SAR(10 g) = 1.56 mW/g

Maximum value of SAR (measured) = 2.577 mW/g

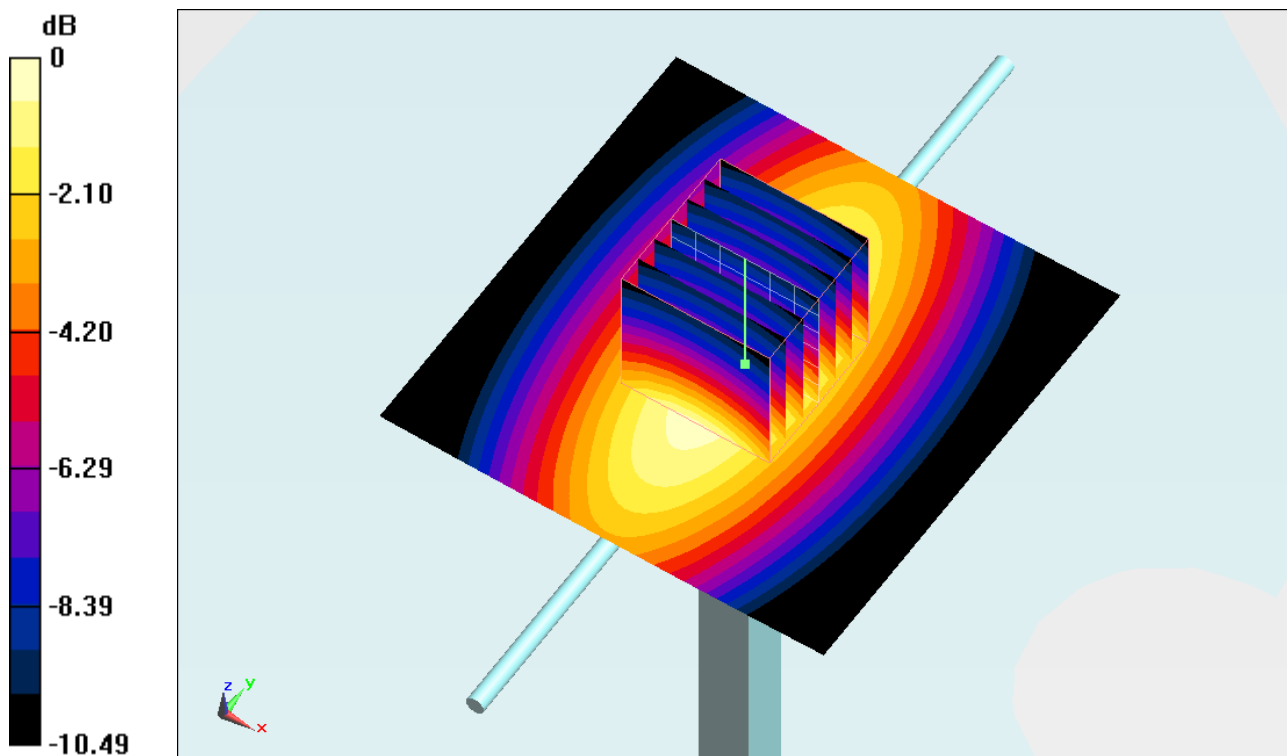

0 dB = 2.580mW/g

System Check_Head_1900MHz_111004

DUT: Dipole 1900 MHz

Communication System: CW; Frequency: 1900 MHz; Duty Cycle: 1:1

Medium: HSL_1900_111004 Medium parameters used: $f = 1900$ MHz; $\sigma = 1.45$ mho/m; $\epsilon_r = 38.2$; $\rho = 1000$ kg/m³

Ambient Temperature : 22.4 °C ; Liquid Temperature : 21.4 °C

DASY4 Configuration:

- Probe: EX3DV4 - SN3697; ConvF(7.46, 7.46, 7.46); Calibrated: 2011-09-02
- Sensor-Surface: 4mm (Mechanical Surface Detection)
- Electronics: DAE4 Sn905; Calibrated: 2011-06-24
- Phantom: SAM_Left; Type: SAM; Serial: TP-1150
- Measurement SW: DASY4, V4.7 Build 80; Postprocessing SW: SEMCAD, V1.8 Build 186

Pin=250mW/Area Scan (61x61x1): Measurement grid: dx=15mm, dy=15mm

Maximum value of SAR (interpolated) = 11.7 mW/g

Pin=250mW/Zoom Scan (7x7x7)/Cube 0: Measurement grid: dx=5mm, dy=5mm, dz=5mm

Reference Value = 85.0 V/m; Power Drift = 0.029 dB

Peak SAR (extrapolated) = 17.5 W/kg

SAR(1 g) = 9.6 mW/g; SAR(10 g) = 5.21 mW/g

Maximum value of SAR (measured) = 10.7 mW/g

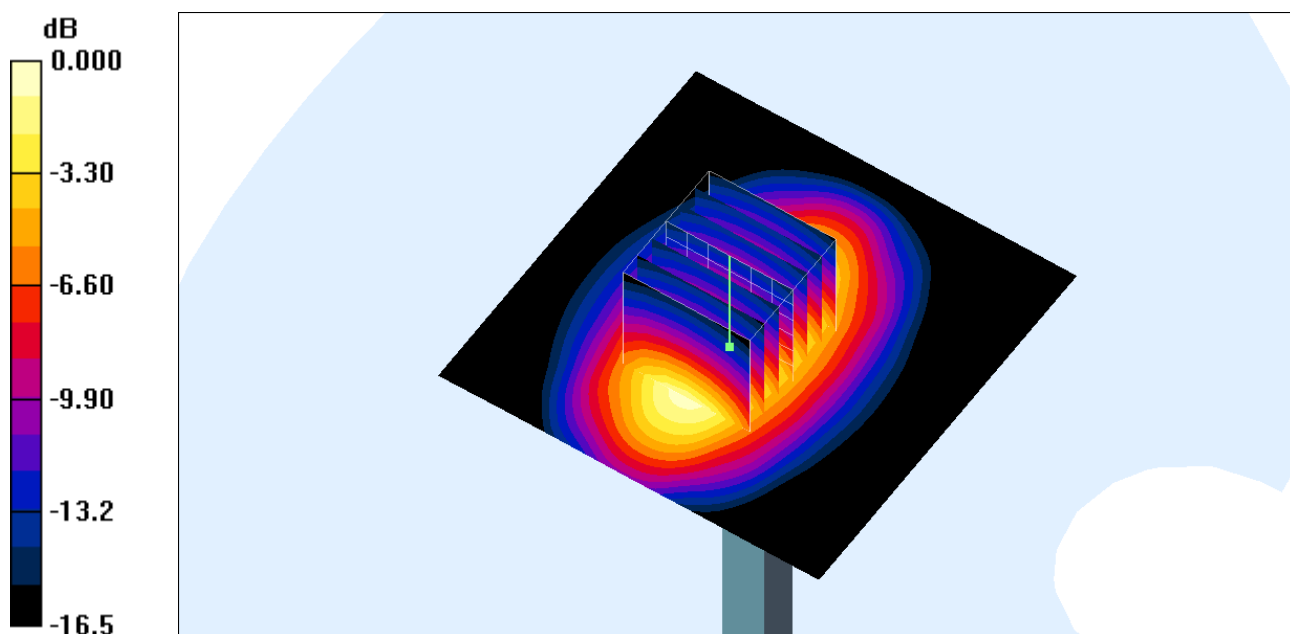

System Check_Head_2450MHz_110916

DUT: Dipole 2450 MHz

Communication System: CW; Frequency: 2450 MHz; Duty Cycle: 1:1

Medium: HSL_2450_110916 Medium parameters used: $f = 2450$ MHz; $\sigma = 1.83$ mho/m; $\epsilon_r = 39.5$; $\rho = 1000$ kg/m³

Ambient Temperature : 22.6 °C ; Liquid Temperature : 21.6 °C

DASY4 Configuration:

- Probe: EX3DV4 - SN3697; ConvF(6.67, 6.67, 6.67); Calibrated: 2011/9/2
- Sensor-Surface: 4mm (Mechanical Surface Detection)
- Electronics: DAE4 Sn1279; Calibrated: 2011/6/17
- Phantom: SAM-Right; Type: QD 000 P40 C; Serial: TP-1383
- Measurement SW: DASY4, V4.7 Build 80; Postprocessing SW: SEMCAD, V1.8 Build 186

Pin=250mW/Area Scan (61x61x1): Measurement grid: dx=15mm, dy=15mm

Maximum value of SAR (interpolated) = 15.2 mW/g

Pin=250mW/Zoom Scan (7x7x7)/Cube 0: Measurement grid: dx=5mm, dy=5mm, dz=5mm

Reference Value = 91.2 V/m; Power Drift = -0.087 dB

Peak SAR (extrapolated) = 29.0 W/kg

SAR(1 g) = 13.4 mW/g; SAR(10 g) = 6.06 mW/g

Maximum value of SAR (measured) = 15.3 mW/g

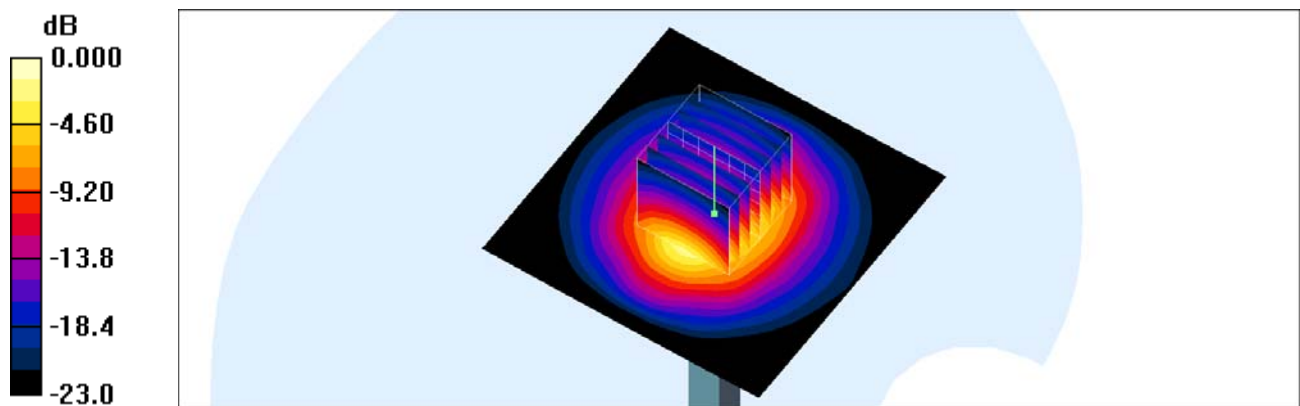

0 dB = 15.3mW/g

System Check_Body_835MHz_111004

DUT: Dipole 835 MHz

Communication System: CW; Frequency: 835 MHz; Duty Cycle: 1:1

Medium: MSL_850_111004 Medium parameters used: $f = 835 \text{ MHz}$; $\sigma = 0.955 \text{ mho/m}$; $\epsilon_r = 52.69$; $\rho = 1000 \text{ kg/m}^3$

Ambient Temperature : 22.5 °C ; Liquid Temperature : 21.5 °C

DASY5 Configuration:

- Probe: ES3DV3 - SN3270; ConvF(6.16, 6.16, 6.16); Calibrated: 2011/9/12
- Sensor-Surface: 4mm (Mechanical Surface Detection)
- Electronics: DAE3 Sn495; Calibrated: 2011/4/28
- Phantom: SAM Right; Type: QD000P40CD; Serial: TP:1644
- Measurement SW: DASY52, Version 52.6 (2); SEMCAD X Version 14.4.5 (3634)

Pin=250mW/Area Scan (61x61x1): Measurement grid: dx=15mm, dy=15mm

Maximum value of SAR (interpolated) = 2.585 mW/g

Pin=250mW/Zoom Scan (7x7x7)/Cube 0: Measurement grid: dx=5mm, dy=5mm, dz=5mm

Reference Value = 52.452 V/m; Power Drift = -0.01 dB

Peak SAR (extrapolated) = 3.612 W/kg

SAR(1 g) = 2.4 mW/g; SAR(10 g) = 1.57 mW/g

Maximum value of SAR (measured) = 2.594 mW/g

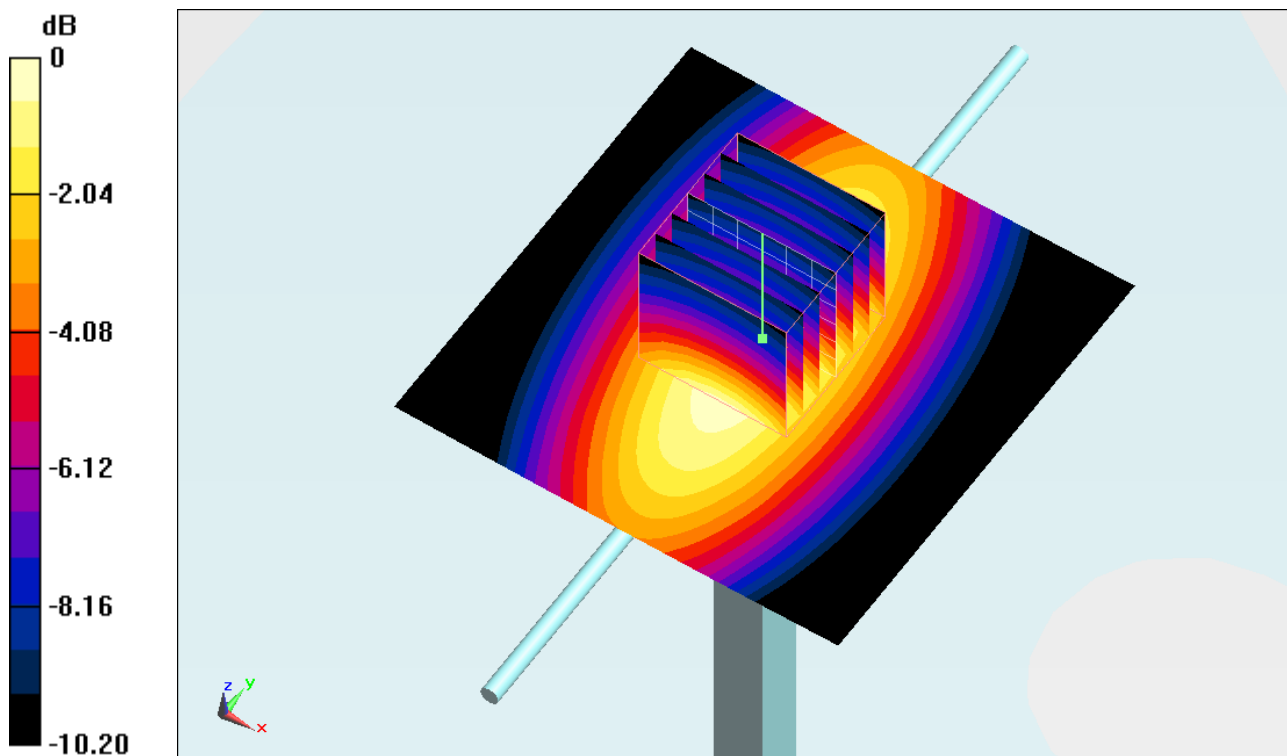

0 dB = 2.590mW/g

System Check_Body_1900MHz_111003

DUT: Dipole 1900 MHz

Communication System: CW; Frequency: 1900 MHz; Duty Cycle: 1:1

Medium: MSL_1900_111003 Medium parameters used: $f = 1900$ MHz; $\sigma = 1.55$ mho/m; $\epsilon_r = 51.9$; $\rho = 1000$ kg/m³

Ambient Temperature : 22.3 °C; Liquid Temperature : 21.3 °C

DASY4 Configuration:

- Probe: EX3DV4 - SN3697; ConvF(6.96, 6.96, 6.96); Calibrated: 2011-09-02
- Sensor-Surface: 4mm (Mechanical Surface Detection)
- Electronics: DAE4 Sn905; Calibrated: 2011-06-24
- Phantom: SAM_Right; Type: SAM; Serial: TP-1303
- Measurement SW: DASY4, V4.7 Build 80; Postprocessing SW: SEMCAD, V1.8 Build 186

Pin=250mW/Area Scan (61x61x1): Measurement grid: dx=15mm, dy=15mm

Maximum value of SAR (interpolated) = 11.9 mW/g

Pin=250mW/Zoom Scan (7x7x7)/Cube 0: Measurement grid: dx=5mm, dy=5mm, dz=5mm

Reference Value = 75.5 V/m; Power Drift = 0.085 dB

Peak SAR (extrapolated) = 18.0 W/kg

SAR(1 g) = 9.79 mW/g; SAR(10 g) = 5.3 mW/g

Maximum value of SAR (measured) = 10.9 mW/g

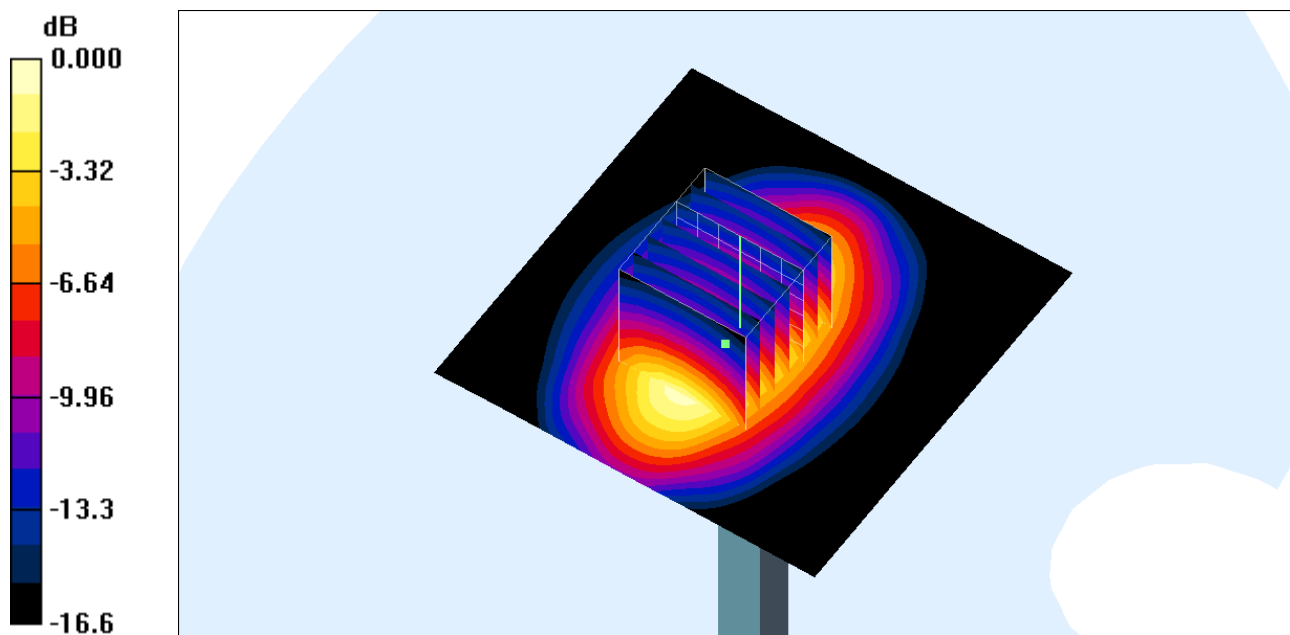

System Check_Body_1900MHz_111014

DUT: Dipole 1900 MHz

Communication System: CW; Frequency: 1900 MHz; Duty Cycle: 1:1

Medium: MSL_1900_111014 Medium parameters used: $f = 1900$ MHz; $\sigma = 1.53$ mho/m; $\epsilon_r = 52.5$; $\rho = 1000$ kg/m³

Ambient Temperature : 22.6 °C; Liquid Temperature : 21.6 °C

DASY4 Configuration:

- Probe: ES3DV3 - SN3270; ConvF(4.64, 4.64, 4.64); Calibrated: 2011/9/12
- Sensor-Surface: 4mm (Mechanical Surface Detection)
- Electronics: DAE4 Sn905; Calibrated: 2011/6/24
- Phantom: SAM-Left; Type: QD 000 P40 C; Serial: TP-1478
- Measurement SW: DASY4, V4.7 Build 80; Postprocessing SW: SEMCAD, V1.8 Build 186

Pin=250mW/Area Scan (91x91x1): Measurement grid: dx=10mm, dy=10mm

Maximum value of SAR (interpolated) = 10.7 mW/g

Pin=250mW/Zoom Scan (7x7x7)/Cube 0: Measurement grid: dx=5mm, dy=5mm, dz=5mm

Reference Value = 84.5 V/m; Power Drift = -0.037 dB

Peak SAR (extrapolated) = 17.1 W/kg

SAR(1 g) = 9.31 mW/g; SAR(10 g) = 4.8 mW/g

Maximum value of SAR (measured) = 10.6 mW/g

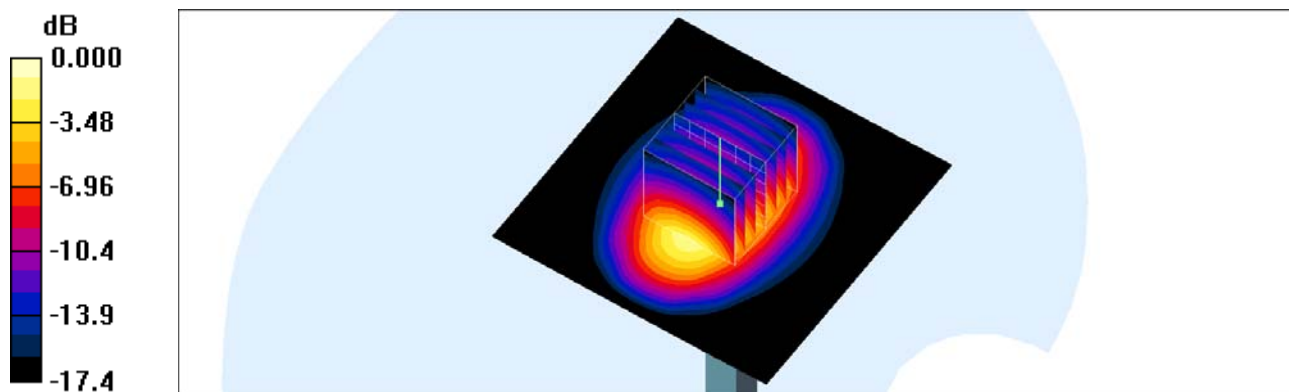

0 dB = 10.6mW/g

System Check_Body_2450MHz_110917

DUT: Dipole 2450 MHz

Communication System: CW; Frequency: 2450 MHz; Duty Cycle: 1:1

Medium: MSL_2450_110917 Medium parameters used: $f = 2450$ MHz; $\sigma = 1.97$ mho/m; $\epsilon_r = 53.8$; $\rho = 1000$ kg/m³

Ambient Temperature : 22.4 °C ; Liquid Temperature : 21.4 °C

DASY4 Configuration:

- Probe: EX3DV4 - SN3697; ConvF(6.73, 6.73, 6.73); Calibrated: 2011/9/2
- Sensor-Surface: 4mm (Mechanical Surface Detection)
- Electronics: DAE4 Sn1279; Calibrated: 2011/6/17
- Phantom: ELI 4.0_Front; Type: QDOVA001BB; Serial: 1026
- Measurement SW: DASY4, V4.7 Build 80; Postprocessing SW: SEMCAD, V1.8 Build 186

Pin=250mW/Area Scan (91x91x1): Measurement grid: dx=10mm, dy=10mm

Maximum value of SAR (interpolated) = 14.2 mW/g

Pin=250mW/Zoom Scan (7x7x7)/Cube 0: Measurement grid: dx=5mm, dy=5mm, dz=5mm

Reference Value = 82.7 V/m; Power Drift = -0.017 dB

Peak SAR (extrapolated) = 24.6 W/kg

SAR(1 g) = 12.1 mW/g; SAR(10 g) = 5.66 mW/g

Maximum value of SAR (measured) = 14.0 mW/g

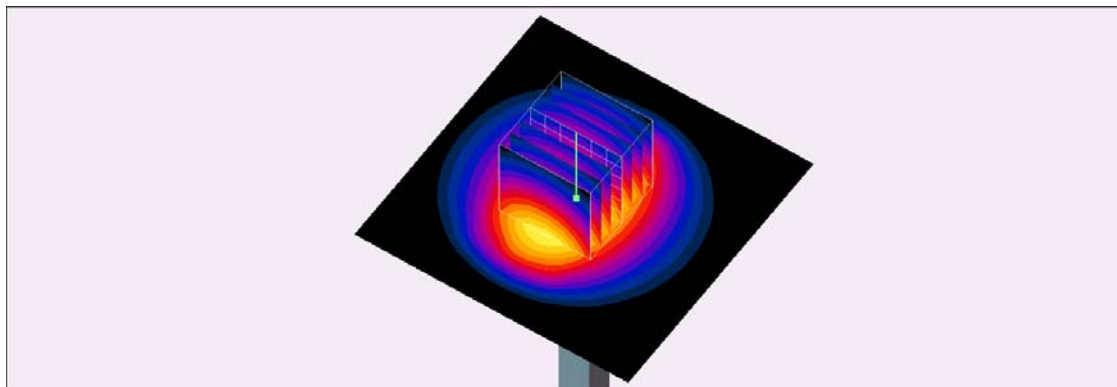
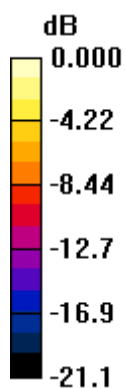

0 dB = 14.0mW/g