



RADIO TEST REPORT

Test Report No. : 13021063S-A-R1

Applicant : Citizen Watch Co., Ltd.
Type of Equipment : BLE Hybrid Watch
Model No. : YF10MV-01
FCC ID : YUQ-YF1MV01
Test regulation : FCC Part 15 Subpart C: 2019
Test Result : Complied (Refer to SECTION 3.2)

1. This test report shall not be reproduced in full or partial, without the written approval of UL Japan, Inc.
2. The results in this report apply only to the sample tested.
3. This sample tested is in compliance with the limits of the above regulation.
4. The test results in this test report are traceable to the national or international standards.
5. This test report must not be used by the customer to claim product certification, approval, or endorsement by the A2LA accreditation body.
6. This test report covers Radio technical requirements. It does not cover administrative issues such as Manual or non-Radio test related Requirements. (if applicable)
7. The all test items in this test report are conducted by UL Japan, Inc. Shonan EMC Lab.
8. The opinions and the interpretations to the result of the description in this report are outside scopes where UL Japan has been accredited.
9. The information provided from the customer for this report is identified in SECTION 1.
10. This report is a revised version of 13021063S-A. 13021063S-A is replaced with this report.

Date of test: November 5 to 12, 2019

Representative test engineer: *H. Sato*
Hiromasa Sato
Engineer
Consumer Technology Division

Approved by: *K. Takeyama*
Kazutaka Takeyama
Engineer
Consumer Technology Division



CERTIFICATE 1266.03

- The testing in which "Non-accreditation" is displayed is outside the accreditation scopes in UL Japan.
 There is no testing item of "Non-accreditation".

UL Japan, Inc.
Shonan EMC Lab.

1-22-3 Megumigaoka, Hiratsuka-shi, Kanagawa-ken, 259-1220 JAPAN
Telephone : +81 463 50 6400
Facsimile : +81 463 50 6401

REVISION HISTORY

Original Test Report No.: 13021063S-A

Revision	Test report No.	Date	Page revised	Contents
- (Original)	13021063S-A	November 28, 2019	-	-
1	13021063S-A-R1	December 3, 2019	7	Update of worst margin: deletion of "Hori"
			18	Deletion of remarks: "The average output power was measured with the lowest order modulation and lowest data rate configuration in each IEEE 802.11 mode based on KDB 248227 D01."
			21	Update of data: change font from bold to regular for worst margin "5.3" of 7206.000 MHz, Hori.
			26	Update of data: eliminate fourth harmonic wave from the plot chart

UL Japan, Inc.

Shonan EMC Lab.

1-22-3 Megumigaoka, Hiratsuka-shi, Kanagawa-ken, 259-1220 JAPAN

Telephone : +81 463 50 6400

Facsimile : +81 463 50 6401

Reference: Abbreviations (Including words undescribed in this report)

A2LA	The American Association for Laboratory Accreditation	MCS	Modulation and Coding Scheme
AC	Alternating Current	MRA	Mutual Recognition Arrangement
AFH	Adaptive Frequency Hopping	N/A	Not Applicable
AM	Amplitude Modulation	NIST	National Institute of Standards and Technology
Amp, AMP	Amplifier	NS	No signal detect.
ANSI	American National Standards Institute	NSA	Normalized Site Attenuation
Ant, ANT	Antenna	NVLAP	National Voluntary Laboratory Accreditation Program
AP	Access Point	OBW	Occupied Band Width
ASK	Amplitude Shift Keying	OFDM	Orthogonal Frequency Division Multiplexing
Atten., ATT	Attenuator	P/M	Power meter
AV	Average	PCB	Printed Circuit Board
BPSK	Binary Phase-Shift Keying	PER	Packet Error Rate
BR	Bluetooth Basic Rate	PHY	Physical Layer
BT	Bluetooth	PK	Peak
BT LE	Bluetooth Low Energy	PN	Pseudo random Noise
BW	BandWidth	PRBS	Pseudo-Random Bit Sequence
Cal Int	Calibration Interval	PSD	Power Spectral Density
CCK	Complementary Code Keying	QAM	Quadrature Amplitude Modulation
Ch., CH	Channel	QP	Quasi-Peak
CISPR	Comite International Special des Perturbations Radioelectriques	QPSK	Quadri-Phase Shift Keying
CW	Continuous Wave	RBW	Resolution Band Width
DBPSK	Differential BPSK	RDS	Radio Data System
DC	Direct Current	RE	Radio Equipment
D-factor	Distance factor	RF	Radio Frequency
DFS	Dynamic Frequency Selection	RMS	Root Mean Square
DQPSK	Differential QPSK	RSS	Radio Standards Specifications
DSSS	Direct Sequence Spread Spectrum	Rx	Receiving
EDR	Enhanced Data Rate	SA, S/A	Spectrum Analyzer
EIRP, e.i.r.p.	Equivalent Isotropically Radiated Power	SG	Signal Generator
EMC	ElectroMagnetic Compatibility	SVSWR	Site-Voltage Standing Wave Ratio
EMI	ElectroMagnetic Interference	TR	Test Receiver
EN	European Norm	Tx	Transmitting
ERP, e.r.p.	Effective Radiated Power	VBW	Video BandWidth
EU	European Union	Vert.	Vertical
EUT	Equipment Under Test	WLAN	Wireless LAN
Fac.	Factor		
FCC	Federal Communications Commission		
FHSS	Frequency Hopping Spread Spectrum		
FM	Frequency Modulation		
Freq.	Frequency		
FSK	Frequency Shift Keying		
GFSK	Gaussian Frequency-Shift Keying		
GNSS	Global Navigation Satellite System		
GPS	Global Positioning System		
Hori.	Horizontal		
ICES	Interference-Causing Equipment Standard		
IEC	International Electrotechnical Commission		
IEEE	Institute of Electrical and Electronics Engineers		
IF	Intermediate Frequency		
ILAC	International Laboratory Accreditation Conference		
ISED	Innovation, Science and Economic Development Canada		
ISO	International Organization for Standardization		
JAB	Japan Accreditation Board		
LAN	Local Area Network		
LIMS	Laboratory Information Management System		

UL Japan, Inc.

Shonan EMC Lab.

1-22-3 Megumigaoka, Hiratsuka-shi, Kanagawa-ken, 259-1220 JAPAN

Telephone : +81 463 50 6400

Facsimile : +81 463 50 6401

CONTENTS	PAGE
SECTION 1: Customer information.....	5
SECTION 2: Equipment under test (E.U.T.).....	5
SECTION 3: Test specification, procedures & results.....	6
SECTION 4: Operation of E.U.T. during testing.....	10
SECTION 5: Radiated Spurious Emission	11
SECTION 6: Antenna Terminal Conducted Tests.....	13
APPENDIX 1: Test data	14
6 dB Bandwidth and 99 % Occupied Bandwidth.....	14
Maximum Peak Output Power	17
Average Output Power	18
Radiated Spurious Emission	21
Conducted Spurious Emission	27
Power Density	30
APPENDIX 2: Test instruments	32
APPENDIX 3: Photographs of test setup	34
Radiated Spurious Emission	34
Pre-Check Worst Case Position	35

SECTION 1: Customer information

Company Name : Citizen Watch Co., Ltd.
Address : 6-1-12, Tanashi-cho, nishi-tokyo-shi, Tokyo 188-8511, Japan
Telephone Number : +81-42-467-6218
Facsimile Number : +81-42-467-1549
Contact Person : Shunya Shoji

The information provided from the customer is as follows;

- Applicant, Type of Equipment, Model No., FCC ID on the cover and other relevant pages
- Operating/Test Mode(s) (Mode(s)) on all the relevant pages
- SECTION 1: Customer information
- SECTION 2: Equipment under test (E.U.T.)
- SECTION 4: Operation of E.U.T. during testing

* The laboratory is exempted from liability of any test results affected from the above information in SECTION 2 and 4.

SECTION 2: Equipment under test (E.U.T.)

2.1 Identification of E.U.T.

Type of Equipment : BLE Hybrid Watch
Model No. : YF10MV-01
Serial No. : Refer to SECTION 4.2
Rating : DC 3.0 V (Battery)
Receipt Date of Sample : November 1, 2019
(Information from test lab.)
Country of Mass-production : China
Condition of EUT : Production prototype
(Not for Sale: This sample is equivalent to mass-produced items.)
Modification of EUT : No Modification by the test lab.

2.2 Product Description

Model: YF10MV-01 (referred to as the EUT in this report) is a BLE Hybrid Watch.

Radio Specification

Equipment Type : Transceiver
Frequency of Operation : 2402 MHz - 2480 MHz
Type of Modulation : GFSK
Antenna Type : Loop Trace
Antenna Gain : -10 dBi
Clock frequency (Maximum) : 16 MHz

SECTION 3: Test specification, procedures & results

3.1 Test Specification

Test Specification : FCC Part 15 Subpart C
FCC Part 15 final revised on July 19, 2019 and effective August 19, 2019 except 15.258

Title : FCC 47 CFR Part 15 Radio Frequency Device Subpart C Intentional Radiators
Section 15.207 Conducted limits
Section 15.247 Operation within the bands 902-928 MHz, 2400-2483.5 MHz,
and 5725-5850 MHz

* Also the EUT complies with FCC Part 15 Subpart B.

3.2 Procedures and results

Item	Test Procedure	Specification	Worst margin	Results	Remarks
Conducted Emission	FCC: ANSI C63.10-2013 6. Standard test methods ISED: RSS-Gen 8.8	FCC: Section 15.207 ----- ISED: RSS-Gen 8.8	-	N/A	*1)
6dB Bandwidth	FCC: KDB 558074 D01 15.247 Meas Guidance v05r02 ISED: -	FCC: Section 15.247(a)(2) ----- ISED: RSS-247 5.2(a)	See data.	Complied a)	Conducted
Maximum Peak Output Power	FCC: KDB 558074 D01 15.247 Meas Guidance v05r02 ISED: RSS-Gen 6.12	FCC: Section 15.247(b)(3) ----- ISED: RSS-247 5.4(d)		Complied b)	Conducted
Power Density	FCC: KDB 558074 D01 15.247 Meas Guidance v05r02 ISED: -	FCC: Section 15.247(e) ----- ISED: RSS-247 5.2(b)		Complied c)	Conducted
Spurious Emission Restricted Band Edges	FCC: KDB 558074 D01 15.247 Meas Guidance v05r02	FCC: Section 15.247(d) ----- ISED: RSS-247 5.5 RSS-Gen 8.9 RSS-Gen 8.10	5.3 dB 7206.000 MHz, AV, Vert.	Complied d), e)	Conducted (below 30 MHz)/
	ISED: RSS-Gen 6.13				Radiated (above 30 MHz) *2)
<p>Note: UL Japan, Inc.'s EMI Work Procedures No. 13-EM-W0420 and 13-EM-W0422. *1) The test is not applicable since the EUT has no AC mains. *2) Radiated test was selected over 30 MHz based on section 15.247(d) and KDB 558074 D01 15.247 Meas Guidance v05r02 8.5 and 8.6. a) Refer to APPENDIX 1 (data of 6 dB Bandwidth and 99 % Occupied Bandwidth) b) Refer to APPENDIX 1 (data of Maximum Peak Output Power) c) Refer to APPENDIX 1 (data of Power Density) d) Refer to APPENDIX 1 (data of Conducted Spurious Emission) e) Refer to APPENDIX 1 (data of Radiated Spurious Emission)</p>					
<p>Symbols: Complied The data of this test item has enough margin, more than the measurement uncertainty. Complied# The data of this test item meets the limits unless the measurement uncertainty is taken into consideration.</p>					

* In case any questions arise about test procedure, ANSI C63.10: 2013 is also referred.

FCC Part 15.31 (e)

The EUT provides stable voltage constantly to the wireless transmitter regardless of input voltage. Instead of a new battery, the EUT was supplied from PC via USB for the test. That does not affect the test result, therefore the EUT complies with the requirement.

FCC Part 15.203 Antenna requirement

It is impossible for end users to replace the antenna, because the antenna is mounted inside of the EUT. Therefore, the equipment complies with the antenna requirement.

UL Japan, Inc.

Shonan EMC Lab.

1-22-3 Megumigaoka, Hiratsuka-shi, Kanagawa-ken, 259-1220 JAPAN

Telephone : +81 463 50 6400

Facsimile : +81 463 50 6401

3.3 Addition to standard

Item	Test Procedure	Specification	Worst margin	Results	Remarks
99% Occupied Bandwidth	RSS-Gen 6.7	IC: -	N/A	- a)	Conducted
Note: UL Japan, Inc.'s EMI Work Procedures No. 13-EM-W0420 and 13-EM-W0422.					
a) Refer to APPENDIX 1 (data of 6 dB Bandwidth and 99 % Occupied Bandwidth)					
Symbols:					
Complied		The data of this test item has enough margin, more than the measurement uncertainty.			
Complied#		The data of this test item meets the limits unless the measurement uncertainty is taken into consideration.			

Other than above, no addition, exclusion nor deviation has been made from the standard.

3.4 Uncertainty

There is no applicable rule of uncertainty in this applied standard. Therefore, the results are derived depending on whether or not laboratory uncertainty is applied.

The following uncertainties have been calculated to provide a confidence level of 95 % using a coverage factor $k=2$.
Shonan EMC Lab.

Item	Frequency range	Uncertainty (+/-)			
		No. 1 SAC / SR	No. 2 SAC / SR	No. 3 SAC / SR	No. 4 SAC / SR
Radiated emission (Measurement distance: 3 m)	30 MHz-200 MHz	4.6 dB	4.6 dB	4.6 dB	-
	200 MHz-1 GHz	6.0 dB	6.0 dB	6.0 dB	-
	1 GHz-6 GHz	4.9 dB	4.9 dB	4.9 dB	-
	6 GHz-18 GHz	5.5 dB	5.5 dB	5.5 dB	-
Radiated emission (Measurement distance: 1 m)	1 GHz-18 GHz	5.8 dB	5.8 dB	5.8 dB	-
	18 GHz-40 GHz	5.7 dB	5.7 dB	5.7 dB	-

SAC=Semi-Anechoic Chamber

SR= Shielded Room is applied besides radiated emission

Antenna terminal test	Uncertainty (+/-)
Power Measurement above 1 GHz (Average Detector)_SPM-06	0.81 dB
Power Measurement above 1 GHz (Peak Detector)_SPM-06	1.53 dB
Power Measurement above 1 GHz (Average Detector)_SPM-07	0.95 dB
Power Measurement above 1 GHz (Peak Detector)_SPM-07	1.21 dB
Power Measurement above 1 GHz (Average Detector)_SPM-13	0.90 dB
Power Measurement above 1 GHz (Peak Detector)_SPM-13	1.04 dB
Spurious emission (Conducted) below 1GHz	1.8 dB
Spurious emission (Conducted) 1 GHz-3 GHz	1.7 dB
Spurious emission (Conducted) 3 GHz-18 GHz	2.3 dB
Spurious emission (Conducted) 18 GHz-26.5 GHz	2.4 dB
Spurious emission (Conducted) 26.5 GHz-40 GHz	2.4 dB
Bandwidth Measurement	0.61 %
Duty cycle and Time Measurement	0.012 %

UL Japan, Inc.

Shonan EMC Lab.

1-22-3 Megumigaoka, Hiratsuka-shi, Kanagawa-ken, 259-1220 JAPAN

Telephone : +81 463 50 6400

Facsimile : +81 463 50 6401

3.5 Test Location

UL Japan, Inc. Shonan EMC Lab.

1-22-3, Megumigaoka, Hiratsuka-shi, Kanagawa-ken 259-1220 JAPAN

Telephone: +81 463 50 6400, Facsimile: +81 463 50 6401

A2LA Certificate Number: 1266.03 (FCC Test Firm Registration Number: 626366, ISED Lab Company Number: 2973D)

Test site	Width x Depth x Height (m)	Size of reference ground plane (m) / horizontal conducting plane	Maximum measurement distance
No.1 Semi-anechoic chamber	20.6 x 11.3 x 7.65	20.6 x 11.3	10 m
No.2 Semi-anechoic chamber	20.6 x 11.3 x 7.65	20.6 x 11.3	10 m
No.3 Semi-anechoic chamber	12.7 x 7.7 x 5.35	12.7 x 7.7	5 m
No.4 Semi-anechoic chamber	8.1 x 5.1 x 3.55	8.1 x 5.1	-
No.1 Shielded room	6.8 x 4.1 x 2.7	6.8 x 4.1	-
No.2 Shielded room	6.8 x 4.1 x 2.7	6.8 x 4.1	-
No.3 Shielded room	6.3 x 4.7 x 2.7	6.3 x 4.7	-
No.4 Shielded room	4.4 x 4.7 x 2.7	4.4 x 4.7	-
No.5 Shielded room	7.8 x 6.4 x 2.7	7.8 x 6.4	-
No.6 Shielded room	7.8 x 6.4 x 2.7	7.8 x 6.4	-
No.8 shielded room	3.45 x 5.5 x 2.4	3.45 x 5.5	-
No.1 Measurement room	2.55 x 4.1 x 2.5	-	-

3.6 Test data, Test instruments, and Test set up

Refer to APPENDIX.

UL Japan, Inc.

Shonan EMC Lab.

1-22-3 Megumigaoka, Hiratsuka-shi, Kanagawa-ken, 259-1220 JAPAN

Telephone : +81 463 50 6400

Facsimile : +81 463 50 6401

SECTION 4: Operation of E.U.T. during testing

4 4.1 Operating Mode(s)

Mode	Tested frequency	Remarks*
Tx, Bluetooth Low Energy	2402 MHz 2440 MHz 2480 MHz	Maximum Packet Size, PRBS9
*Power of the EUT was set by the software as follows; Power settings: Fixed Software: Connection Manager Ver.3.0.10 *This setting of software is the worst case. Any conditions under the normal use do not exceed the condition of setting. In addition, end users cannot change the settings of the output power of the product.		

4.2 Configuration and peripherals

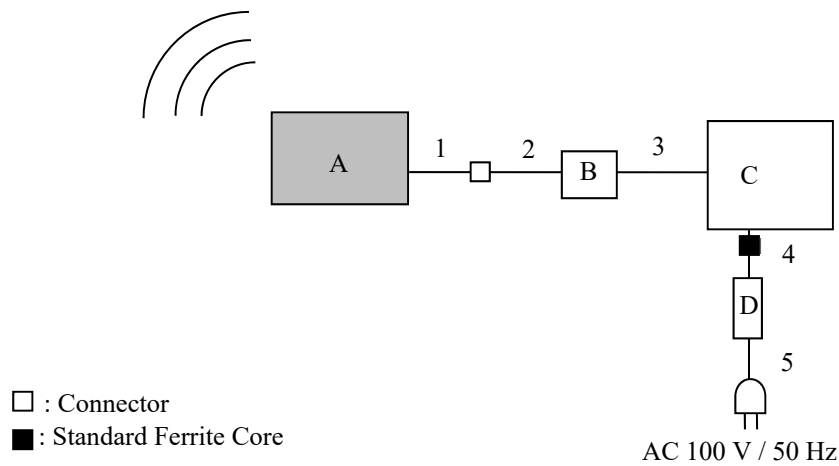

* Cabling and setup(s) were taken into consideration and test data was taken under worse case conditions.

Description of EUT and Support equipment

No.	Item	Model number	Serial number	Manufacturer	Remarks
A	BLE Hybrid Watch	YF10MV-01	YF10MV003 *1) YF10MV001 *2)	CITIZEN WATCH CO., LTD.	EUT
B	Development Kit	-	-	-	-
C	Laptop Computer	PC-VJ23LLZGR	66000071A	NEC	-
D	AC Adapter	ADP-45TD E	6115924DB	NEC	-

*1) Used for Antenna Terminal conducted test

*2) Used for Radiated Emission test

List of cables used

No.	Name	Length (m)	Shield		Remarks
			Cable	Connector	
1	Signal	0.1	Unshielded	Unshielded	*3)
2	Signal	0.15	Unshielded	Unshielded	-
3	USB	0.9	Shielded	Shielded	-
4	DC	1.8	Unshielded	Unshielded	-
5	AC	0.9	Unshielded	Unshielded	-

*3) Cable for test operation

UL Japan, Inc.

Shonan EMC Lab.

1-22-3 Megumigaoka, Hiratsuka-shi, Kanagawa-ken, 259-1220 JAPAN

Telephone : +81 463 50 6400

Facsimile : +81 463 50 6401

SECTION 5: Radiated Spurious Emission

Test Procedure

It was measured based on "8.5 and 8.6 of KDB 558074 D01 15.247 Meas Guidance v05r02".

[For below 1 GHz]

EUT was placed on a platform of nominal size, 1.0 m by 2.0 m, raised 0.8 m above the conducting ground plane. The table is made of expanded polystyrol and expanded polypropylene and the table top is covered with polycarbonate. That has very low permittivity. The Radiated Electric Field Strength has been measured in a Semi Anechoic Chamber with a ground plane.

[For above 1 GHz]

EUT was placed on a urethane platform of nominal size, 0.5 m by 0.5 m, raised 1.5 m above the conducting ground plane. The Radiated Electric Field Strength has been measured in a Semi Anechoic Chamber with absorbent materials lined on a ground plane.

The height of the measuring antenna varied between 1 m and 4 m and EUT was rotated a full revolution in order to obtain the maximum value of the electric field strength.

Test antenna was aimed at the EUT for receiving the maximum signal and always kept within the illumination area of the 3 dB beamwidth of the antenna.

The measurements were performed for both vertical and horizontal antenna polarization with the Test Receiver, or the Spectrum Analyzer.

The measurements were made with the following detector function of the test receiver and the Spectrum analyzer (in linear mode).

The test was made with the detector (RBW/VBW) in the following table.

When using Spectrum analyzer, the test was made with adjusting span to zero by using peak hold.

Test Antennas are used as below;

Frequency	30 MHz to 200 MHz	200 MHz to 1 GHz	Above 1 GHz
Antenna Type	Biconical	Logperiodic	Horn

In any 100 kHz bandwidth outside the restricted band in which the spread spectrum intentional radiator is operating, the radio frequency power that is produced by the intentional radiator confirmed 20 dB below that in the 100 kHz bandwidth within the band that contains the highest level of the desired power, based on a radiated measurement.

20 dBc was applied to the frequency over the limit of FCC 15.209 / Table 4 of RSS-Gen 8.9(ISED) and outside the restricted band of FCC15.205 / Table 6 of RSS-Gen 8.10 (ISED).

Frequency	30 MHz to 1 GHz	Above 1 GHz		20 dBc
Instrument used	Test Receiver	Spectrum Analyzer		Spectrum Analyzer
Detector	QP	PK	AV *1)	PK
IF Bandwidth	BW 120 kHz	RBW: 1 MHz VBW: 3 MHz	11.12.2.5.2 RBW: 1 MHz VBW: 3 MHz Detector: Power Averaging (Linear voltage) Trace: 100 traces Duty factor was added to the results.	RBW: 100 kHz VBW: 300 kHz

*1) Average Power Measurement was performed based on ANSI C63.10-2013.

UL Japan, Inc.

Shonan EMC Lab.

1-22-3 Megumigaoka, Hiratsuka-shi, Kanagawa-ken, 259-1220 JAPAN

Telephone : +81 463 50 6400

Facsimile : +81 463 50 6401

Figure 1: Test Setup

Below 1 GHz

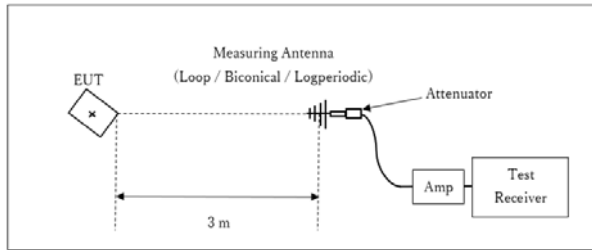

× : Center of turn table

Test Distance: 3 m

1 GHz - 13 GHz

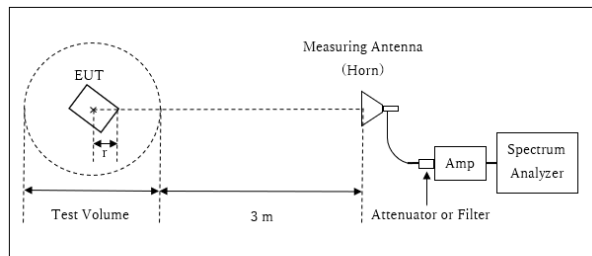

r : Radius of an outer periphery of EUT

× : Center of turn table

Distance Factor: $20 \times \log(3.965 \text{ m} / 3.0 \text{ m}) = 2.43 \text{ dB}$

* Test Distance: $(3 + \text{Test Volume} / 2) - r = 3.965 \text{ m}$

Test Volume : 2.0 m

(Test Volume has been calibrated based on CISPR 16-1-4.)

$r = 0.035 \text{ m}$

13 GHz – 26.5 GHz

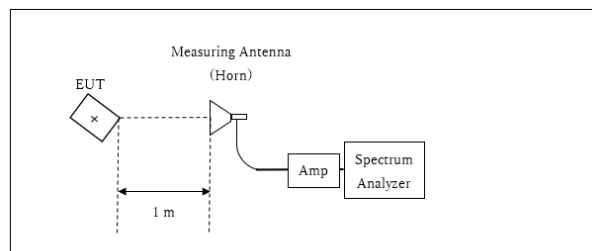

× : Center of turn table

Distance Factor: $20 \times \log(1.0 \text{ m} / 3.0 \text{ m}) = -9.54 \text{ dB}$

*Test Distance: 1 m

The carrier level and noise levels were confirmed at each position of X, Y and Z axes of EUT to see the position of maximum noise, and the test was made at the position that has the maximum noise.

Antenna polarization	Carrier	Spurious (30 MHz - 1 GHz)	Spurious (1 GHz - 2.8 GHz)	Spurious (2.8 GHz - 13 GHz)	Spurious (13 GHz - 18 GHz)	Spurious (18 GHz - 26.5 GHz)
Horizontal	Z	X	Z	X	X	X
Vertical	Z	X	Z	Z	X	X

The test results and limit are rounded off to one decimal place, so some differences might be observed.

Measurement range : 30 MHz - 26.5 GHz

Test data : APPENDIX

Test result : Pass

UL Japan, Inc.

Shonan EMC Lab.

1-22-3 Megumigaoka, Hiratsuka-shi, Kanagawa-ken, 259-1220 JAPAN

Telephone : +81 463 50 6400

Facsimile : +81 463 50 6401

SECTION 6: Antenna Terminal Conducted Tests

Test Procedure

The tests were made with below setting connected to the antenna port.

Test	Span	RBW	VBW	Sweep time	Detector	Trace	Instrument used
6dB Bandwidth	10 MHz	100 kHz	300 kHz	Auto	Peak	Max Hold	Spectrum Analyzer
99% Occupied Bandwidth *1)	Enough width to display emission skirts	1 to 5 % of OBW	Three times of RBW	Auto	Peak	Max Hold	Spectrum Analyzer
Maximum Peak Output Power	-	-	-	Auto	Peak/Average *2)	-	Power Meter (Sensor: 160 MHz BW)
Peak Power Density	1.5 times the 6dB Bandwidth	3 kHz	9.1 kHz	Auto	Peak	Max Hold	Spectrum Analyzer *3)
Conducted Spurious Emission *4)	9kHz to 150kHz	200 Hz	620 Hz	Auto	Peak	Max Hold	Spectrum Analyzer
	150kHz to 30MHz	10 kHz	30 kHz				
*1) Peak hold was applied as Worst-case measurement. *2) Reference data *3) Section 11.10.2 Method PKPSD (peak PSD) of "ANSI C63.10-2013". *4) In the frequency range below 30MHz, RBW was narrowed to separate the noise contents. Then, wide-band noise near the limit was checked separately, however the noise was not detected as shown in the chart. (9 kHz - 150 kHz: RBW = 200 Hz, 150 kHz - 30 MHz: RBW = 10 kHz)							

The test results and limit are rounded off to two decimals place, so some differences might be observed.
The equipment and cables were not used for factor 0 dB of the data sheets.

Test data : APPENDIX
Test result : Pass

APPENDIX 1: Test data

6 dB Bandwidth and 99 % Occupied Bandwidth

Report No. 13021063S-A-R1
Test place Shonan EMC Lab. No.5 Shielded Room
Date November 5, 2019
Temperature / Humidity 25 deg. C / 45 % RH
Engineer Hiromasa Sato
Mode Tx BT LE

Mode	Frequency [MHz]	99% Occupied Bandwidth [kHz]	6dB Bandwidth [MHz]	Limit for 6dB Bandwidth [MHz]
BT LE	2402	1081.1	0.733	> 0.5000
	2440	1085.1	0.736	> 0.5000
	2480	1084.6	0.748	> 0.5000

99%Occupied Bandwidth

BT LE

2402 MHz

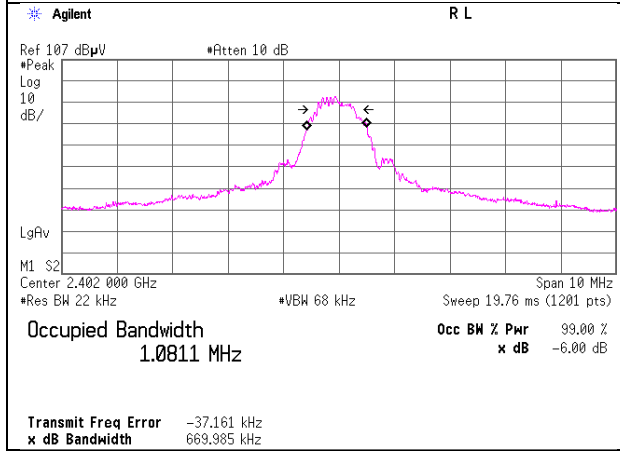

2440 MHz

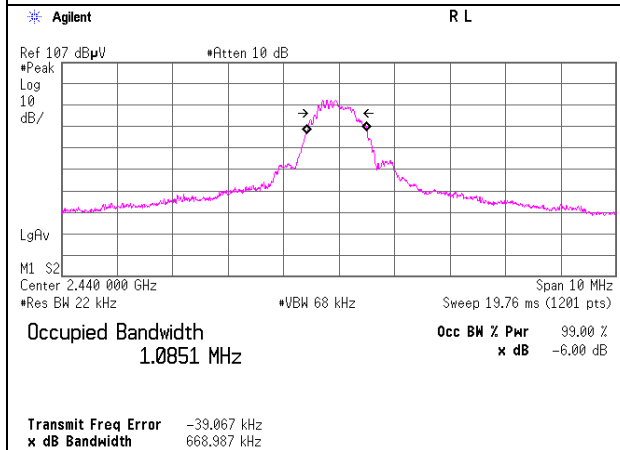

2480 MHz

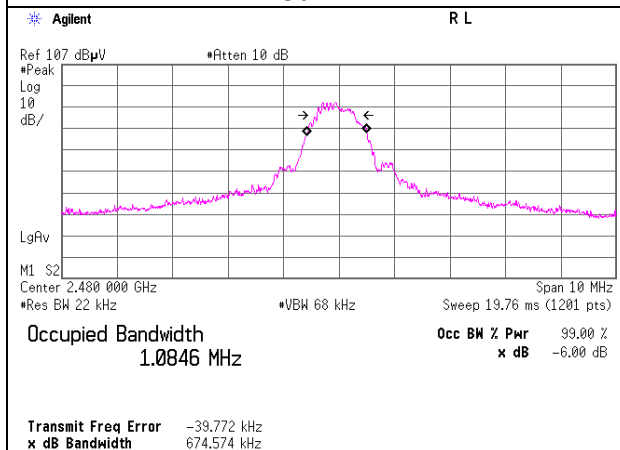

UL Japan, Inc.

Shonan EMC Lab.

1-22-3 Megumigaoka, Hiratsuka-shi, Kanagawa-ken, 259-1220 JAPAN

Telephone : +81 463 50 6400

Facsimile : +81 463 50 6401

6dB Bandwidth

BT LE

2402 MHz

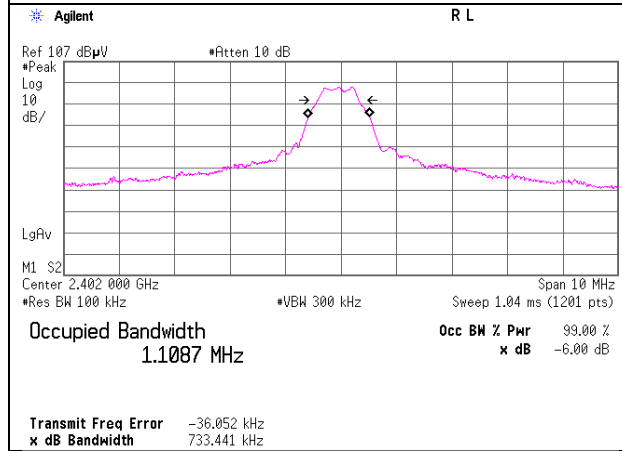

2440 MHz

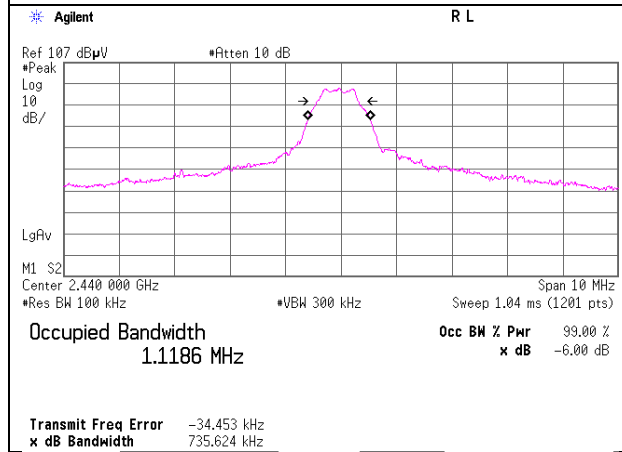

2480 MHz

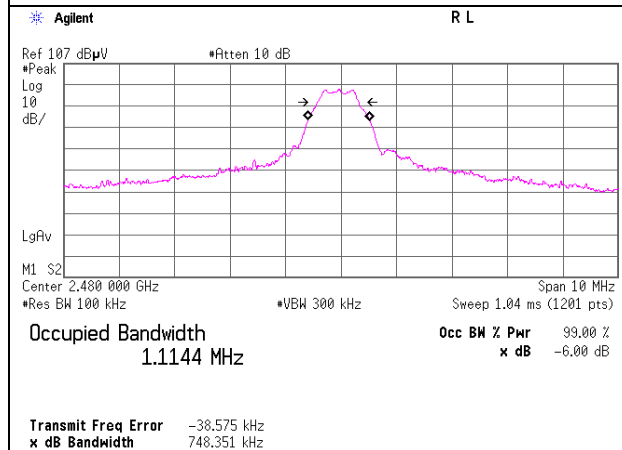

Maximum Peak Output Power

Report No. 13021063S-A-R1
Test place Shonan EMC Lab. No.5 Shielded Room
Date November 5, 2019
Temperature / Humidity 25 deg. C / 45 % RH
Engineer Hiromasa Sato
Mode Tx BT LE

Freq. [MHz]	Reading [dBm]	Cable Loss [dB]	Atten. Loss [dB]	Conducted Power					e.i.r.p. for RSS-247					
				Result		Limit		Margin [dB]	Antenna Gain [dBi]	Result		Limit		Margin [dB]
				[dBm]	[mW]	[dBm]	[mW]			[dBm]	[mW]	[dBm]	[mW]	
2402	-11.17	1.15	9.92	-0.10	0.98	30.00	1000	30.10	-10.00	-10.10	0.10	36.02	4000	46.12
2440	-11.33	1.15	9.92	-0.26	0.94	30.00	1000	30.26	-10.00	-10.26	0.09	36.02	4000	46.28
2480	-11.47	1.16	9.92	-0.39	0.91	30.00	1000	30.39	-10.00	-10.39	0.09	36.02	4000	46.41

Sample Calculation:

Result = Reading + Cable Loss (including the cable(s) customer supplied) + Attenuator Loss

e.i.r.p. Result = Conducted Power Result + Antenna Gain

UL Japan, Inc.

Shonan EMC Lab.

1-22-3 Megumigaoka, Hiratsuka-shi, Kanagawa-ken, 259-1220 JAPAN

Telephone : +81 463 50 6400

Facsimile : +81 463 50 6401

Average Output Power
(Reference data for RF Exposure)

Report No. 13021063S-A-R1
Test place Shonan EMC Lab. No.5 Shielded Room
Date November 5, 2019
Temperature / Humidity 25 deg. C / 45 % RH
Engineer Hiromasa Sato
Mode Tx BT LE

BT LE

Freq. [MHz]	Reading [dBm]	Cable Loss [dB]	Atten. Loss [dB]	Result (Time average)		Duty factor [dB]	Result (Burst power average)	
				[dBm]	[mW]		[dBm]	[mW]
2402	-13.73	1.15	9.92	-2.66	0.54	2.01	-0.65	0.86
2440	-13.89	1.15	9.92	-2.82	0.52	2.01	-0.81	0.83
2480	-14.07	1.16	9.92	-2.99	0.50	2.01	-0.98	0.80

Sample Calculation:

Result (Time average) = Reading + Cable Loss (including the cable(s) customer supplied) + Attenuator Loss

Result (Burst power average) = Time average + Duty factor

Burst rate confirmation(for Average Output Power)

Report No. 13021063S-A-R1
 Test place Shonan EMC Lab. No.5 Shielded Room
 Date November 5, 2019
 Temperature / Humidity 25 deg. C / 45 % RH
 Engineer Hiromasa Sato
 Mode Tx BT LE

BT LE

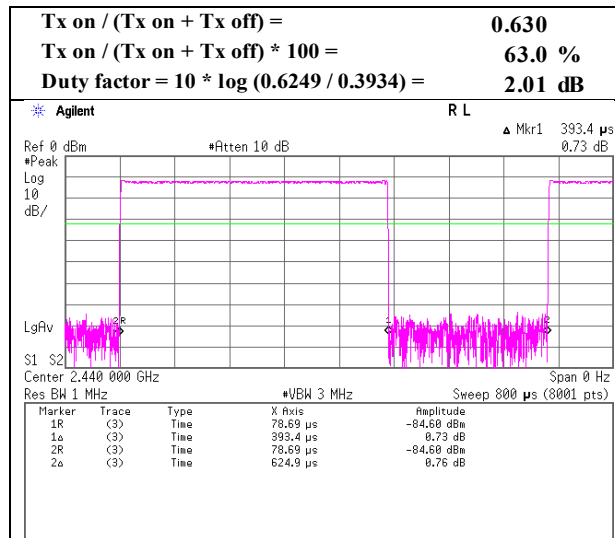

* Since the burst rate is not different between the channels, the data has been obtained on the representative channel.

Burst rate confirmation(for Radiated Spurious Emission)

Report No. 13021063S-A-R1
 Test place Shonan EMC Lab. No.5 Shielded Room
 Date November 5, 2019
 Temperature / Humidity 25 deg. C / 45 % RH
 Engineer Hiromasa Sato
 Mode Tx BT LE

BT LE

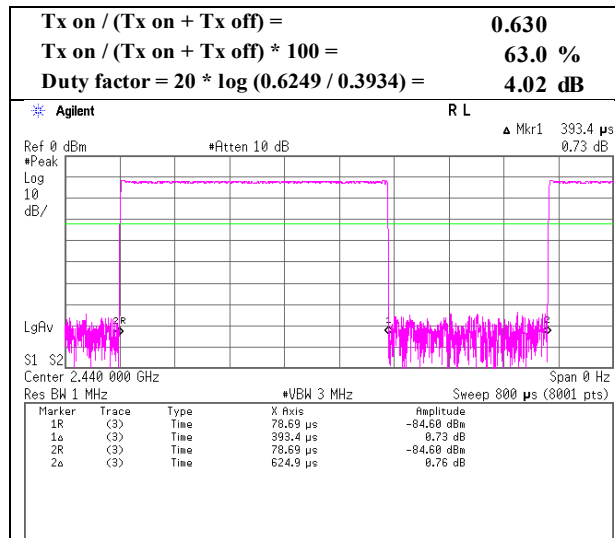

* Since the burst rate is not different between the channels, the data has been obtained on the representative channel.

Radiated Spurious Emission

Report No.	13021063S-A-R1	
Test place	Shonan EMC Lab.	
Semi Anechoic Chamber	No.3	No.3
Date	November 9, 2019	November 12, 2019
Temperature / Humidity	23 deg. C / 30 % RH	24 deg. C / 40 % RH
Engineer	Kazuya Noda	Toshinori Yamada
	(30 MHz - 1000 MHz)	(1 GHz - 26.5 GHz)
Mode	Tx BT LE, 2402 MHz	

(* PK: Peak, AV: Average, QP: Quasi-Peak)

Polarity	Frequency [MHz]	Detector	Reading [dBuV]	Ant.Fac. [dB/m]	Loss [dB]	Gain [dB]	Distance Factor [dB]	Result [dBuV/m]	Limit [dBuV/m]	Margin [dB]	Height [cm]	Angle [deg]	Remark
Hori.	66.129	QP	38.80	6.90	6.56	32.18	0.00	20.08	40.0	19.9	247	135	-
Hori.	154.753	QP	29.50	14.84	7.88	32.12	0.00	20.10	43.5	23.4	220	130	-
Hori.	187.500	QP	26.50	16.14	7.87	32.08	0.00	18.43	43.5	25.0	100	10	-
Hori.	652.036	QP	21.70	19.00	10.19	31.96	0.00	18.93	46.0	27.0	100	1	-
Hori.	703.923	QP	21.90	19.41	10.38	31.85	0.00	19.84	46.0	26.1	100	359	-
Hori.	2390.000	PK	47.86	28.33	14.16	41.59	2.43	51.19	73.9	22.7	127	166	-
Hori.	4804.000	PK	49.35	31.62	6.49	42.88	2.43	47.01	73.9	26.8	134	59	-
Hori.	7206.000	PK	49.41	37.23	8.14	42.92	2.43	54.29	73.9	19.6	100	329	-
Vert.	66.419	QP	35.80	6.86	6.59	32.18	0.00	17.07	40.0	22.9	100	66	-
Vert.	116.359	QP	31.10	12.55	7.27	32.14	0.00	18.78	43.5	24.7	100	191	-
Vert.	198.124	QP	23.50	16.36	7.90	32.07	0.00	15.69	43.5	27.8	100	130	-
Vert.	950.045	QP	21.50	21.59	11.17	30.64	0.00	23.62	46.0	22.3	100	194	-
Vert.	2390.000	PK	47.37	28.33	14.16	41.59	2.43	50.70	73.9	23.2	158	126	-
Vert.	4804.000	PK	50.21	31.62	6.49	42.88	2.43	47.87	73.9	26.0	138	45	-
Vert.	7206.000	PK	48.81	37.23	8.14	42.92	2.43	53.69	73.9	20.2	196	153	-

Result = Reading + Ant.Fac. + Loss (Cable+(Attenuator or Filter)(below 18 GHz)) - Gain(Amplifier) + Distance factor

Distance factor : 1 GHz - 13 GHz : 20log(3.965 m / 3.0 m) = 2.43 dB

13 GHz - 40 GHz : 20log(1.0 m / 3.0 m) = -9.54 dB

Average measurement value with duty factor

Polarity	Frequency [MHz]	Detector	Reading [dBuV]	Ant.Fac. [dB/m]	Loss [dB]	Gain [dB]	Duty Factor [dB]	Distance Factor [dB]	Result [dBuV/m]	Limit [dBuV/m]	Margin [dB]	Remark
Hori.	2390.000	AV	37.81	28.33	14.16	41.59	4.02	2.43	45.16	53.9	8.7	*1)
Hori.	4804.000	AV	40.34	31.62	6.49	42.88	4.02	2.43	42.02	53.9	11.8	-
Hori.	7206.000	AV	39.62	37.23	8.14	42.92	4.02	2.43	48.52	53.9	5.3	-
Vert.	2390.000	AV	37.76	28.33	14.16	41.59	4.02	2.43	45.11	53.9	8.7	*1)
Vert.	4804.000	AV	40.86	31.62	6.49	42.88	4.02	2.43	42.54	53.9	11.3	-
Vert.	7206.000	AV	39.70	37.23	8.14	42.92	4.02	2.43	48.60	53.9	5.3	-

Result = Reading + Ant.Fac. + Loss (Cable+(Attenuator or Filter)(below 18 GHz)) - Gain(Amplifier) + Duty factor + Distance factor

Distance factor : 1 GHz - 13 GHz : 20log(3.965 m / 3.0 m) = 2.43 dB

13 GHz - 40 GHz : 20log(1.0 m / 3.0 m) = -9.54 dB

Duty factor refer to "Duty factor Calculation chart" sheet.

*1) Not out of band emission (Leakage Power)

20 dBc Data Sheet (RBW 100 kHz, VBW 300 kHz)

Polarity	Frequency [MHz]	Detector	Reading [dBuV]	Ant.Fac. [dB/m]	Loss [dB]	Gain [dB]	Distance Factor [dB]	Result [dBuV/m]	Limit [dBuV/m]	Margin [dB]	Remark
Hori.	2402.000	PK	78.95	28.31	14.17	41.60	2.43	82.26	-	-	Carrier
Hori.	2400.000	PK	44.15	28.31	14.16	41.60	2.43	47.45	62.26	14.8	-
Vert.	2402.000	PK	77.95	28.31	14.17	41.60	2.43	81.26	-	-	Carrier
Vert.	2400.000	PK	43.46	28.31	14.16	41.60	2.43	46.76	61.26	14.5	-

Result = Reading + Ant.Fac. + Loss (Cable+(Attenuator or Filter)(below 18 GHz)) - Gain(Amplifier) + Distance factor

Distance factor : 1 GHz - 13 GHz : 20log(3.965 m / 3.0 m) = 2.43 dB

13 GHz - 40 GHz : 20log(1.0 m / 3.0 m) = -9.54 dB

UL Japan, Inc.

Shonan EMC Lab.

1-22-3 Megumigaoka, Hiratsuka-shi, Kanagawa-ken, 259-1220 JAPAN

Telephone : +81 463 50 6400

Facsimile : +81 463 50 6401

Radiated Spurious Emission (Reference Plot for band-edge)

Report No.	13021063S-A-R1
Test place	Shonan EMC Lab.
Semi Anechoic Chamber	No.3
Date	November 12, 2019
Temperature / Humidity	24 deg. C / 40 % RH
Engineer	Toshinori Yamada
Mode	Tx BT LE 2402 MHz

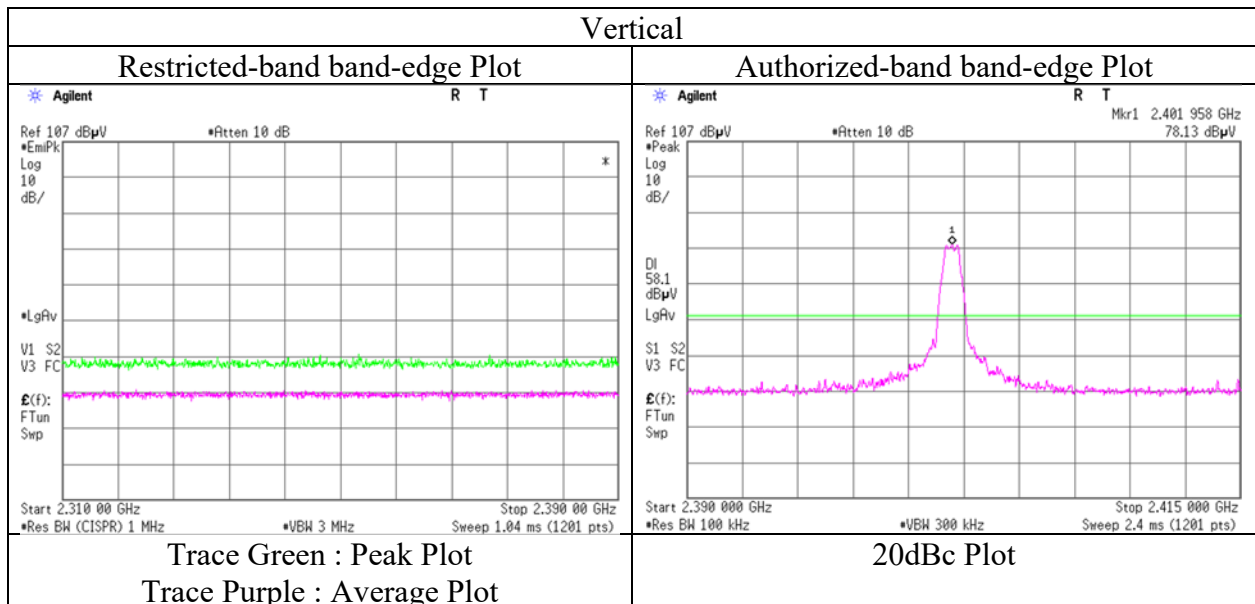
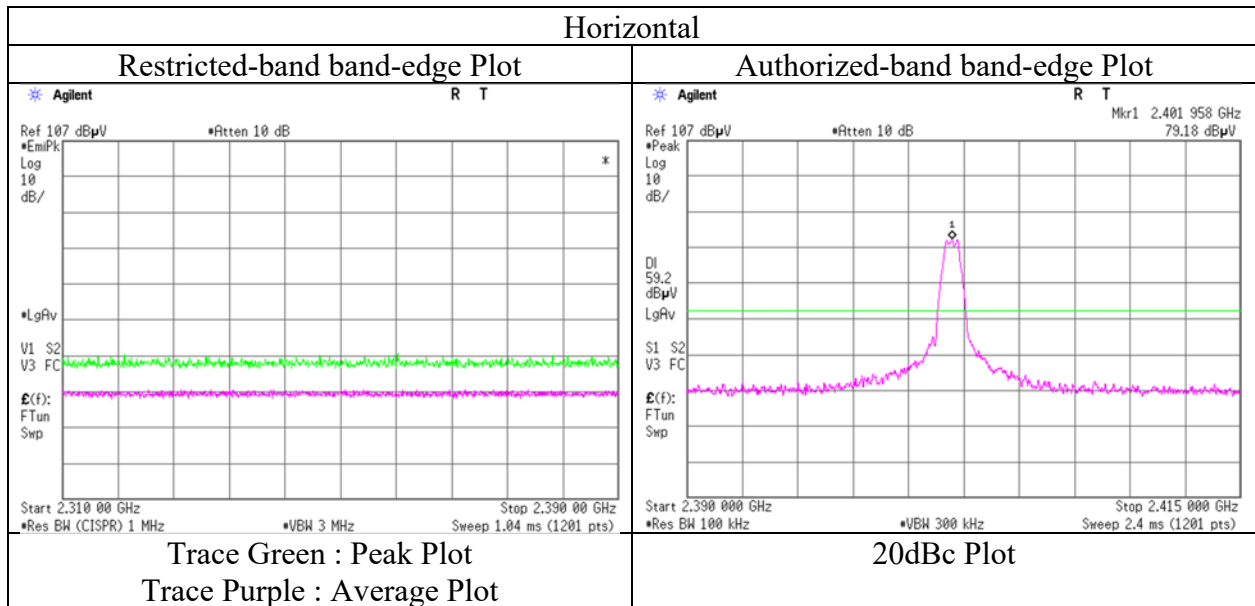

* The measurement was conducted for a sufficiently long enough time to detect any possible spurious emissions. Final result of restricted band edge was shown in tabular data.

Radiated Spurious Emission

Report No.	13021063S-A-R1	
Test place	Shonan EMC Lab.	
Semi Anechoic Chamber	No.3	No.3
Date	November 9, 2019	November 12, 2019
Temperature / Humidity	23 deg. C / 30 % RH	24 deg. C / 40 % RH
Engineer	Kazuya Noda	Toshinori Yamada
	(30 MHz - 1000 MHz)	(1 GHz - 26.5 GHz)
Mode	Tx BT LE, 2440 MHz	

(* PK: Peak, AV: Average, QP: Quasi-Peak)

Polarity	Frequency [MHz]	Detector	Reading [dBuV]	Ant.Fac. [dB/m]	Loss [dB]	Gain [dB]	Distance Factor [dB]	Result [dBuV/m]	Limit [dBuV/m]	Margin [dB]	Height [cm]	Angle [deg]	Remark
Hori.	66.034	QP	37.50	6.92	6.56	32.18	0.00	18.80	40.0	21.2	246	136	-
Hori.	142.030	QP	27.00	14.34	7.69	32.12	0.00	16.91	43.5	26.5	224	155	-
Hori.	159.999	QP	32.70	15.07	7.91	32.11	0.00	23.57	43.5	19.9	192	146	-
Hori.	198.001	QP	28.40	16.35	7.90	32.07	0.00	20.58	43.5	22.9	100	3	-
Hori.	696.649	QP	22.40	19.28	10.36	31.87	0.00	20.17	46.0	25.8	100	14	-
Hori.	4880.000	PK	49.59	31.71	6.52	42.89	2.43	47.36	73.9	26.5	145	265	-
Hori.	7320.000	PK	48.63	37.38	8.15	43.15	2.43	53.44	73.9	20.4	100	333	-
Vert.	33.605	QP	29.30	17.10	6.54	32.19	0.00	20.75	40.0	19.2	100	191	-
Vert.	47.010	QP	26.10	12.15	6.78	32.19	0.00	12.84	40.0	27.1	100	138	-
Vert.	66.314	QP	35.10	6.88	6.58	32.18	0.00	16.38	40.0	23.6	100	66	-
Vert.	871.245	QP	21.70	21.57	10.93	31.25	0.00	22.95	46.0	23.0	100	1	-
Vert.	4880.000	PK	49.40	31.71	6.52	42.89	2.43	47.17	73.9	26.7	189	104	-
Vert.	7320.000	PK	48.97	37.38	8.15	43.15	2.43	53.78	73.9	20.1	147	194	-

Result = Reading + Ant.Fac. + Loss (Cable+(Attenuator or Filter)(below 18 GHz)) - Gain(Amplifier) + Distance factor

Distance factor : 1 GHz - 13 GHz : 20log(3.965 m / 3.0 m) = 2.43 dB

13 GHz - 40 GHz : 20log(1.0 m / 3.0 m) = -9.54 dB

Average measurement value with duty factor

Polarity	Frequency [MHz]	Detector	Reading [dBuV]	Ant.Fac. [dB/m]	Loss [dB]	Gain [dB]	Duty Factor [dB]	Distance Factor [dB]	Result [dBuV/m]	Limit [dBuV/m]	Margin [dB]	Remark
Hori.	4880.000	AV	40.66	31.71	6.52	42.89	4.02	2.43	42.45	53.9	11.4	-
Hori.	7320.000	AV	38.94	37.38	8.15	43.15	4.02	2.43	47.77	53.9	6.1	-
Vert.	4880.000	AV	39.61	31.71	6.52	42.89	4.02	2.43	41.40	53.9	12.5	-
Vert.	7320.000	AV	38.80	37.38	8.15	43.15	4.02	2.43	47.63	53.9	6.2	-

Result = Reading + Ant.Fac. + Loss (Cable+(Attenuator or Filter)(below 18 GHz)) - Gain(Amplifier) + Duty factor + Distance factor

Distance factor : 1 GHz - 13 GHz : 20log(3.965 m / 3.0 m) = 2.43 dB

13 GHz - 40 GHz : 20log(1.0 m / 3.0 m) = -9.54 dB

Duty factor refer to "Duty factor Calculation chart" sheet.

UL Japan, Inc.

Shonan EMC Lab.

1-22-3 Megumigaoka, Hiratsuka-shi, Kanagawa-ken, 259-1220 JAPAN

Telephone : +81 463 50 6400

Facsimile : +81 463 50 6401

Radiated Spurious Emission

Report No.	13021063S-A-R1	
Test place	Shonan EMC Lab.	
Semi Anechoic Chamber	No.3	No.3
Date	November 9, 2019	November 12, 2019
Temperature / Humidity	23 deg. C / 30 % RH	24 deg. C / 40 % RH
Engineer	Kazuya Noda	Toshinori Yamada
	(30 MHz - 1000 MHz)	(1 GHz - 26.5 GHz)
Mode	Tx BT LE, 2480 MHz	

(* PK: Peak, AV: Average, QP: Quasi-Peak)

Polarity	Frequency [MHz]	Detector	Reading [dBuV]	Ant.Fac. [dB/m]	Loss [dB]	Gain [dB]	Distance Factor [dB]	Result [dBuV/m]	Limit [dBuV/m]	Margin [dB]	Height [cm]	Angle [deg]	Remark
Hori.	66.242	QP	37.30	6.89	6.58	32.18	0.00	18.59	40.0	21.4	244	137	
Hori.	160.001	QP	34.00	15.07	7.91	32.11	0.00	24.87	43.5	18.6	192	150	
Hori.	186.545	QP	25.20	16.10	7.87	32.08	0.00	17.09	43.5	26.4	100	4	
Hori.	644.803	QP	22.40	19.01	10.16	31.96	0.00	19.61	46.0	26.3	100	290	
Hori.	871.956	QP	21.40	21.57	10.93	31.25	0.00	22.65	46.0	23.3	100	1	
Hori.	2483.500	PK	53.78	28.24	14.24	41.62	2.43	57.07	73.9	16.8	136	154	
Hori.	4960.000	PK	49.59	31.96	6.55	42.91	2.43	47.62	73.9	26.2	161	99	
Hori.	7440.000	PK	48.62	37.56	8.16	43.38	2.43	53.39	73.9	20.5	148	324	
Vert.	47.553	QP	25.40	11.93	6.78	32.19	0.00	11.92	40.0	28.0	100	136	
Vert.	66.402	QP	35.10	6.86	6.59	32.18	0.00	16.37	40.0	23.6	100	67	
Vert.	156.908	QP	25.70	14.94	7.90	32.11	0.00	16.43	43.5	27.0	100	40	
Vert.	827.219	QP	21.60	20.53	10.80	31.48	0.00	21.45	46.0	24.5	100	359	
Vert.	2483.500	PK	54.49	28.24	14.24	41.62	2.43	57.78	73.9	16.1	300	139	
Vert.	4960.000	PK	49.75	31.96	6.55	42.91	2.43	47.78	73.9	26.1	114	111	
Vert.	7440.000	PK	48.78	37.56	8.16	43.38	2.43	53.55	73.9	20.3	215	142	

Result = Reading + Ant.Fac. + Loss (Cable+(Attenuator or Filter)(below 18 GHz)) - Gain(Amplifier) + Distance factor

Distance factor : 1 GHz - 13 GHz : 20log(3.965 m / 3.0 m) = 2.43 dB

13 GHz - 40 GHz : 20log(1.0 m / 3.0 m) = -9.54 dB

Average measurement value with duty factor

Polarity	Frequency [MHz]	Detector	Reading [dBuV]	Ant.Fac. [dB/m]	Loss [dB]	Gain [dB]	Duty Factor [dB]	Distance Factor [dB]	Result [dBuV/m]	Limit [dBuV/m]	Margin [dB]	Remark
Hori.	2483.500	AV	38.20	28.24	14.24	41.62	4.02	2.43	45.51	53.9	8.3	*1)
Hori.	4960.000	AV	40.52	31.96	6.55	42.91	4.02	2.43	42.57	53.9	11.3	-
Hori.	7440.000	AV	38.93	37.56	8.16	43.38	4.02	2.43	47.72	53.9	6.1	-
Vert.	2483.500	AV	38.24	28.24	14.24	41.62	4.02	2.43	45.55	53.9	8.3	*1)
Vert.	4960.000	AV	40.17	31.96	6.55	42.91	4.02	2.43	42.22	53.9	11.6	-
Vert.	7440.000	AV	39.05	37.56	8.16	43.38	4.02	2.43	47.84	53.9	6.0	-

Result = Reading + Ant.Fac. + Loss (Cable+(Attenuator or Filter)(below 18 GHz)) - Gain(Amplifier) + Duty factor + Distance factor

Distance factor : 1 GHz - 13 GHz : 20log(3.965 m / 3.0 m) = 2.43 dB

13 GHz - 40 GHz : 20log(1.0 m / 3.0 m) = -9.54 dB

Duty factor refer to "Duty factor Calculation chart" sheet.

*1) Not out of band emission (Leakage Power)

Radiated Spurious Emission
(Reference Plot for band-edge)

Report No. 13021063S-A-R1
Test place Shonan EMC Lab.
Semi Anechoic Chamber No.3
Date November 12, 2019
Temperature / Humidity 24 deg. C / 40 % RH
Engineer Toshinori Yamada
Mode Tx BT LE, 2480 MHz

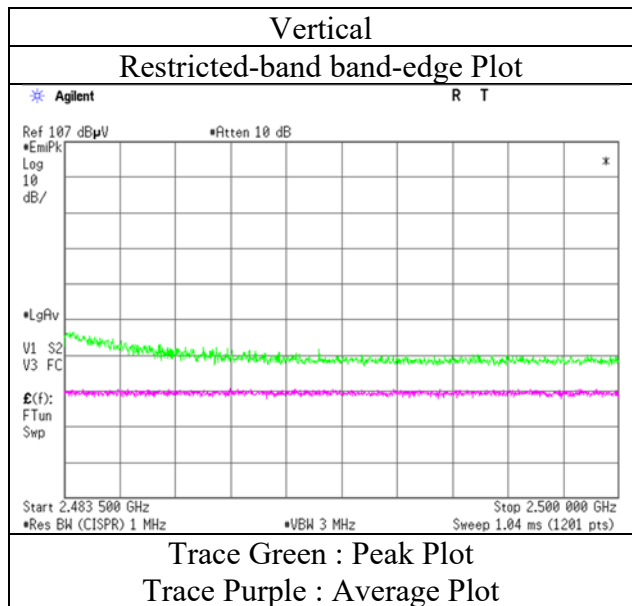
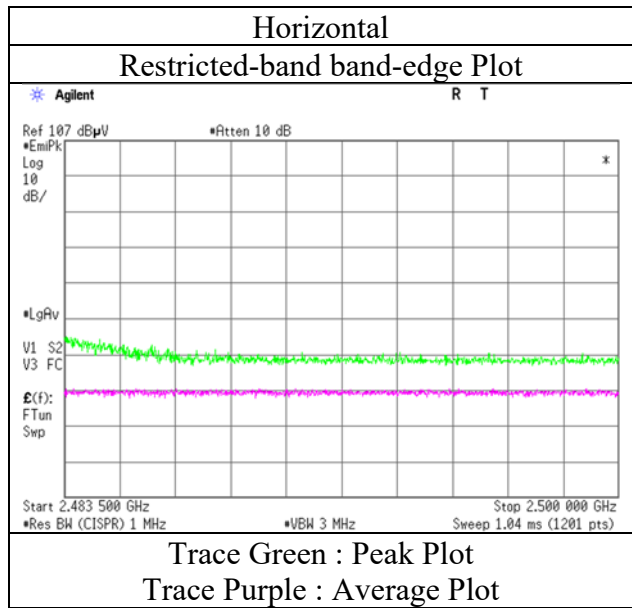

* The measurement was conducted for a sufficiently long enough time to detect any possible spurious emissions. Final result of restricted band edge was shown in tabular data.

Radiated Spurious Emission (Plot data, Worst case)

Report No.	13021063S-A-R1	
Test place	Shonan EMC Lab.	
Semi Anechoic Chamber	No.3	No.3
Date	November 9, 2019	November 12, 2019
Temperature / Humidity	23 deg. C / 30 % RH	24 deg. C / 40 % RH
Engineer	Kazuya Noda (30 MHz - 1000 MHz)	Toshinori Yamada (1 GHz - 26.5 GHz)
Mode	Tx BT LE 2402 MHz	

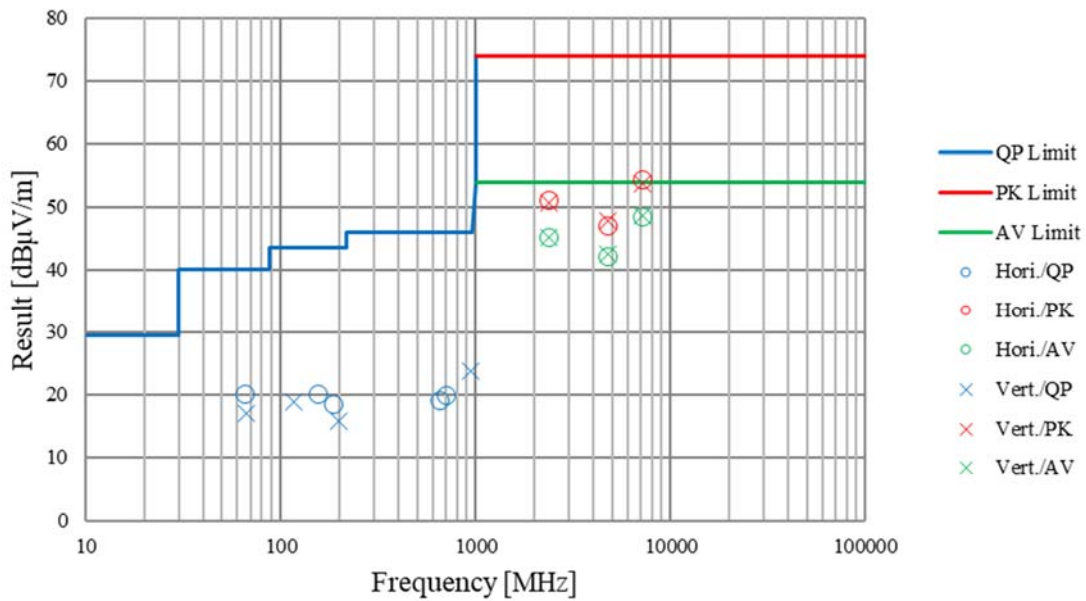

*These plots data contains sufficient number to show the trend of characteristic features for EUT.

Conducted Spurious Emission

Report No. 13021063S-A-R1
 Test place Shonan EMC Lab. No.5 Shielded Room
 Date November 5, 2019
 Temperature / Humidity 25 deg. C / 45 % RH
 Engineer Hiromasa Sato
 Mode Tx BT LE 2402 MHz

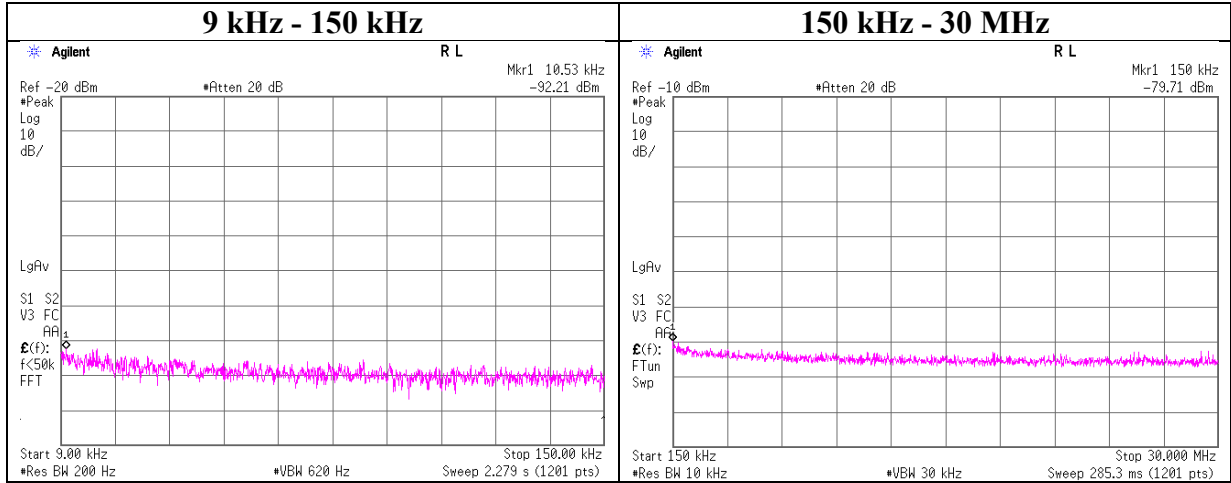

Frequency [kHz]	Reading [dBm]	Cable Loss [dB]	Attenuator Loss [dB]	Antenna Gain* [dBi]	N (Number of Output)	EIRP [dBm]	Distance [m]	Ground bounce [dB]	E (field strength) [dBuV/m]	Limit [dBuV/m]	Margin [dB]	Remark
10.53	-92.2	0.01	9.8	2.0	1	-80.4	300	6.0	-19.1	47.1	66.2	-
150.00	-79.7	0.01	9.8	2.0	1	-67.9	300	6.0	-6.6	24.0	30.6	-

$$E \text{ [dBuV/m]} = \text{EIRP [dBm]} - 20 \log(\text{Distance [m]}) + \text{Ground bounce [dB]} + 104.8 \text{ [dBuV/m]}$$

$$\text{EIRP [dBm]} = \text{Reading [dBm]} + \text{Cable loss [dB]} + \text{Attenuator Loss [dB]} + \text{Antenna gain [dBi]} + 10 * \log(N)$$

N: Number of output

*2.0 dBi was applied to the test result based on ANSI C63.10 since antenna gain was less than 2.0 dBi.

Conducted Spurious Emission

Report No. 13021063S-A-R1
Test place Shonan EMC Lab. No.5 Shielded Room
Date November 5, 2019
Temperature / Humidity 25 deg. C / 45 % RH
Engineer Hiromasa Sato
Mode Tx BT LE 2440 MHz

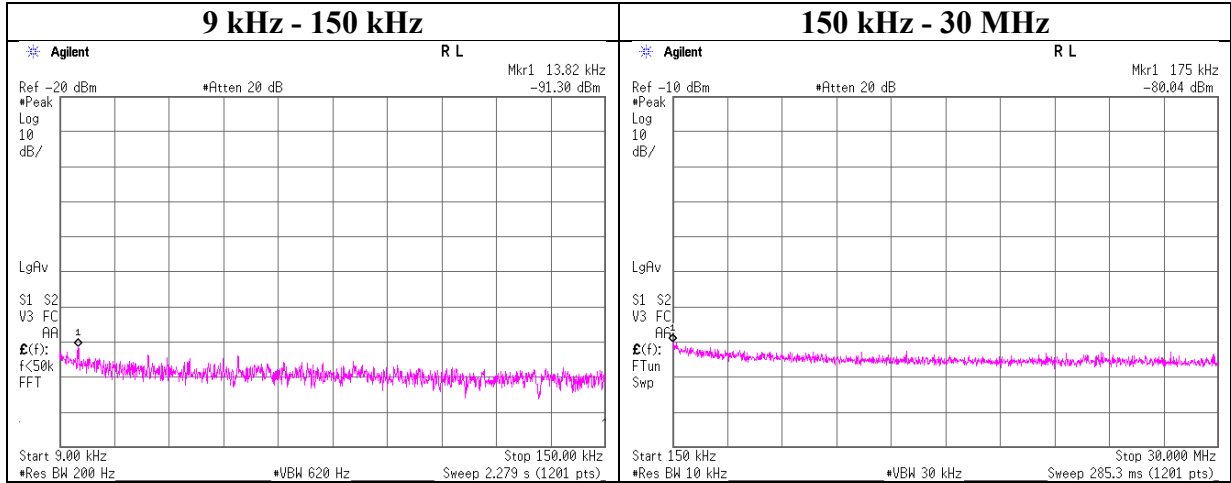

Frequency [kHz]	Reading [dBm]	Cable Loss [dB]	Attenuator Loss [dB]	Antenna Gain* [dBi]	N (Number of Output)	EIRP [dBm]	Distance [m]	Ground bounce [dB]	E (field strength) [dBuV/m]	Limit [dBuV/m]	Margin [dB]	Remark
13.82	-91.3	0.01	9.8	2.0	1	-79.5	300	6.0	-18.2	44.7	62.9	-
175.00	-80.0	0.01	9.8	2.0	1	-68.2	300	6.0	-6.9	22.7	29.6	-

$$E \text{ [dBuV/m]} = \text{EIRP [dBm]} - 20 \log(\text{Distance [m]}) + \text{Ground bounce [dB]} + 104.8 \text{ [dBuV/m]}$$

$$\text{EIRP [dBm]} = \text{Reading [dBm]} + \text{Cable loss [dB]} + \text{Attenuator Loss [dB]} + \text{Antenna gain [dBi]} + 10 * \log(N)$$

N: Number of output

*2.0 dBi was applied to the test result based on ANSI C63.10 since antenna gain was less than 2.0 dBi.

Conducted Spurious Emission

Report No. 13021063S-A-R1
Test place Shonan EMC Lab. No.5 Shielded Room
Date November 5, 2019
Temperature / Humidity 25 deg. C / 45 % RH
Engineer Hiromasa Sato
Mode Tx BT LE 2480 MHz

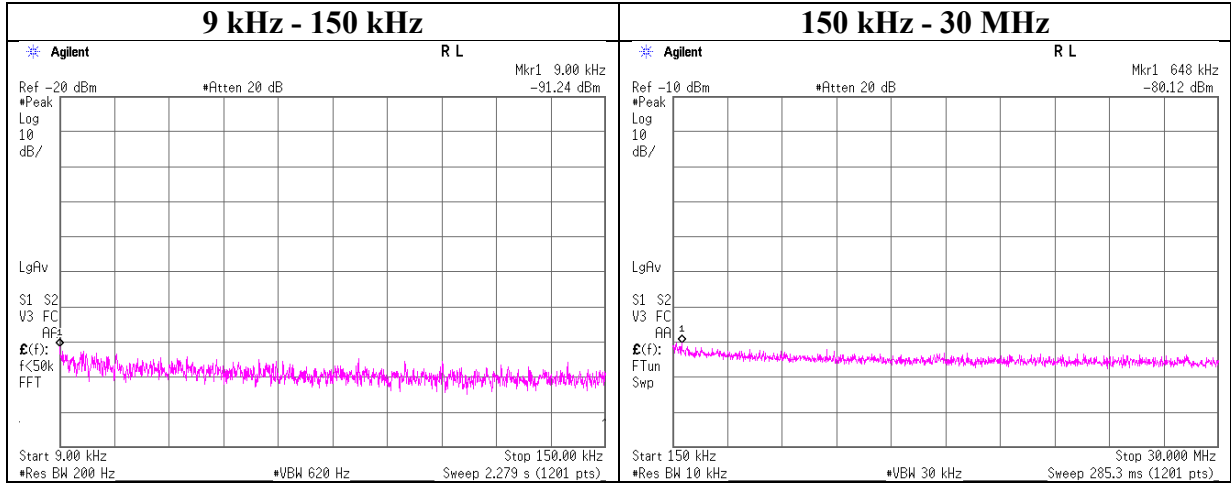

Frequency [kHz]	Reading [dBm]	Cable Loss [dB]	Attenuator Loss [dB]	Antenna Gain* [dBi]	N (Number of Output)	EIRP [dBm]	Distance [m]	Ground bounce [dB]	E (field strength) [dBuV/m]	Limit [dBuV/m]	Margin [dB]	Remark
9.00	-91.2	0.01	9.8	2.0	1	-79.4	300	6.0	-18.1	48.5	66.6	-
648.00	-80.1	0.01	9.8	2.0	1	-68.3	30	6.0	13.0	31.3	18.3	-

$$E \text{ [dBuV/m]} = \text{EIRP [dBm]} - 20 \log(\text{Distance [m]}) + \text{Ground bounce [dB]} + 104.8 \text{ [dBuV/m]}$$

$$\text{EIRP [dBm]} = \text{Reading [dBm]} + \text{Cable loss [dB]} + \text{Attenuator Loss [dB]} + \text{Antenna gain [dBi]} + 10 * \log(N)$$

N: Number of output

*2.0 dBi was applied to the test result based on ANSI C63.10 since antenna gain was less than 2.0 dBi.

Power Density

Report No. 13021063S-A-R1
Test place Shonan EMC Lab. No.5 Shielded Room
Date November 5, 2019
Temperature / Humidity 25 deg. C / 45 % RH
Engineer Hiromasa Sato
Mode Tx BT LE

BT LE

Freq. [MHz]	Reading [dBm]	Cable Loss [dB]	Atten. Loss [dB]	Result [dBm]	Limit [dBm]	Margin [dB]
2402	-26.29	1.15	9.92	-15.22	8.00	23.22
2440	-26.32	1.15	9.92	-15.25	8.00	23.25
2480	-26.50	1.16	9.92	-15.42	8.00	23.42

Sample Calculation:

Result = Reading + Cable Loss (including the cable(s) customer supplied) + Attenuator Loss

Power Density

BT LE

2402 MHz

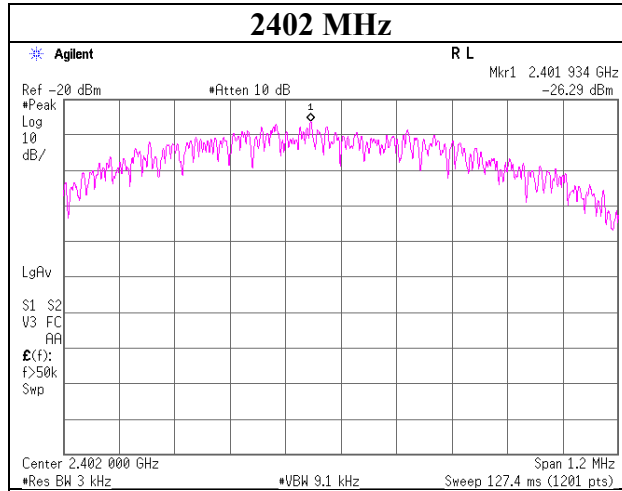

2440 MHz

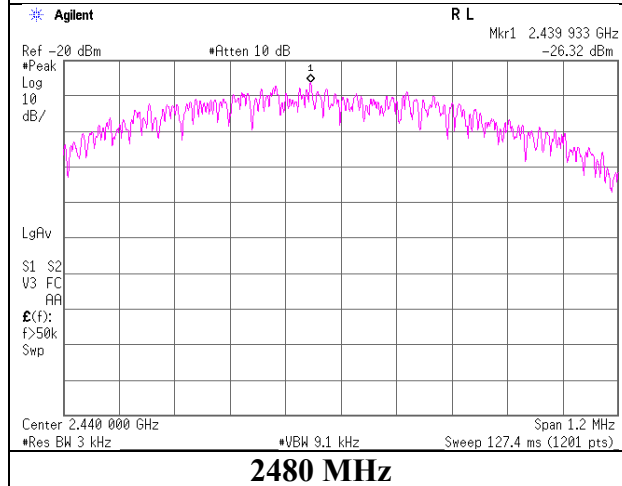

2480 MHz

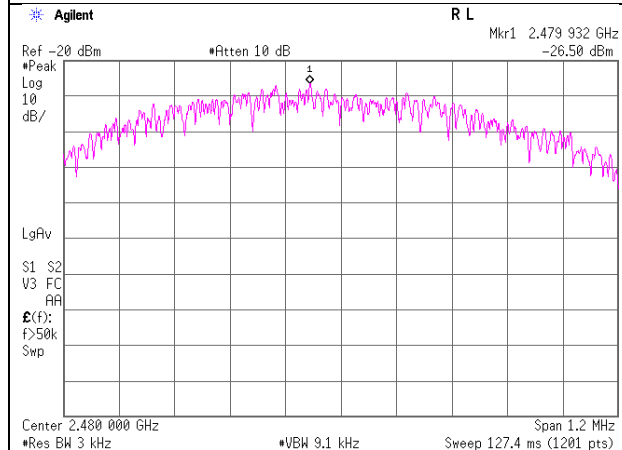

APPENDIX 2: Test instruments

Test Instruments (1/2)

Test Name	Local ID	LIMS ID	Description	Manufacturer	Model	Serial	Last Calibration Date	Calibration Interval (Month)
RE	COTS-SEMI-5	170932	EMI Software	TSJ	TEPTO-DV3(RE,CE,ME,PE)	-	-	-
RE	KJM-02	146432	Measure	TAJIMA	GL19-55	-	-	-
RE	SAEC-03(NSA)	145565	Semi-Anechoic Chamber	TDK	SAEC-03(NSA)	3	2019/04/08	12
RE	SAEC-03(SVSWR)	145566	Semi-Anechoic Chamber	TDK	SAEC-03(SVSWR)	3	2019/05/03	12
RE	SAF-03	145126	Pre Amplifier	SONOMA	310N	290213	2019/02/05	12
RE	SAF-06	145005	Pre Amplifier	Toyo Corporation	TPA0118-36	1440491	2019/02/08	12
RE	SAF-08	145007	Pre Amplifier	Toyo Corporation	HAP18-26W	19	2019/03/05	12
RE	SAT10-05	145136	Attenuator(above 1GHz)	AGILENT	8493C-010	74864	2018/11/25	12
RE	SAT6-13	167094	Attenuator	JFW	50HF-006N	-	2019/02/05	12
RE	SBA-03	145023	Biconical Antenna	Schwarzbeck	BBA9106	91032666	2019/05/07	12
RE	SCC-C1/C2/C3/C4/C5/C10/SRSE-03	145171	Coaxial Cable&RF Selector	Fujikura/Fujikura/Suhner/Suhner/TOYO	8D2W/12DSFA/141PE/141PE/141PE/141PE/NS4906	-/0901-271(RF Selector)	2019/04/19	12
RE	SCC-G43	156380	Coaxial Cable	HUBER+SUNER	SUCOFLEX_104 E	SN MY 13406/4E	2019/07/03	12
RE	SCC-G45	168301	Coaxial Cable	HUBER+SUNER	SUCOFLEX 102 E	800137/2EA	2019/03/26	12
RE	SCC-G57	179540	Coaxial Cable	Huber+Suhner	SUCOFLEX 102	802815/2	2019/05/16	12
RE	SCC-G58	183047	Coaxial Cable	HUBER+SUNER	SUCOFLEX 104	800287/4A	2019/07/23	12
RE	SFL-02	145301	Highpass Filter	MICRO-TRONICS	HPM50111	51	2018/11/16	12
RE	SHA-03	145501	Horn Antenna	Schwarzbeck	BBHA9120D	9120D-739	2019/06/26	12
RE	SHA-04	145512	Horn Antenna	ETS LINDGREN	3160-09	00094868	2019/06/26	12
RE	SLA-07	145529	Logperiodic Antenna	Schwarzbeck	VUSLP9111B	196	2019/05/07	12
RE	SOS-05	146293	Humidity Indicator	A&D	AD-5681	4062518	2019/10/08	12
RE	SSA-02	145800	Spectrum Analyzer	AGILENT	E4448A	MY48250106	2019/04/04	12
RE	STR-08	150463	Test Receiver	Rohde & Schwarz	ESW44	101581	2018/11/28	12
RE	STS-03	146210	Digital Hitester	HIOKI	3805-50	80997823	2019/10/01	12

Test Instruments (2/2)

Test Name	Local ID	LIMS ID	Description	Manufacturer	Model	Serial	Last Calibration Date	Calibration Interval (Month)
AT	SAT10-12	151609	Attenuator	Weinschel Corp.	54A-10	81601	2019/03/27	12
AT	SCC-G37	151614	Coaxial Cable	Junkosha	MWX241-01000KMSKM S/B	1612Q035	2018/12/25	12
AT	SOS-09	146318	Humidity Indicator	A&D	AD-5681	4061484	2018/12/05	12
AT	SPM-07	146247	Power Meter	AGILENT	8990B	MY5100272	2019/07/16	12
AT	SPSS-04	146310	Power sensor	AGILENT	N1923A	MY5326009	2019/07/16	12
AT	SSA-02	145800	Spectrum Analyzer	AGILENT	E4448A	MY48250106	2019/04/04	12

*Hyphens for Last Calibration Date, Calibration Due Date and Cal Int (month) are instruments that Calibration is not required (e.g. software), or instruments checked in advance before use.

The expiration date of the calibration is the end of the expired month.

All equipment is calibrated with valid calibrations. Each measurement data is traceable to the national or international standards.

As for some calibrations performed after the tested dates, those test equipment have been controlled by means of an unbroken chains of calibrations.

Test item: RE: Radiated Emission test
AT: Antenna Terminal Conducted test