



RADIO TEST REPORT

Test Report No. : 12851267S-A-R1

Applicant : Citizen Watch Co., Ltd.
Type of Equipment : BLE Hybrid Watch
Model No. : YF05MV-01
FCC ID : YUQ-YF0MV01
Test regulation : FCC Part 15 Subpart C: 2019
Test Result : Complied (Refer to SECTION 3.2)

1. This test report shall not be reproduced in full or partial, without the written approval of UL Japan, Inc.
2. The results in this report apply only to the sample tested.
3. This sample tested is in compliance with the limits of the above regulation.
4. The test results in this test report are traceable to the national or international standards.
5. This test report must not be used by the customer to claim product certification, approval, or endorsement by the A2LA accreditation body.
6. This test report covers Radio technical requirements.
It does not cover administrative issues such as Manual or non-Radio test related Requirements. (if applicable)
7. The all test items in this test report are conducted by UL Japan, Inc. Shonan EMC Lab.
8. The opinions and the interpretations to the result of the description in this report are outside scopes where UL Japan has been accredited.
9. The information provided from the customer for this report is identified in SECTION 1.
10. This report is a revised version of 12851267S-A. 12851267S-A is replaced with this report.

Date of test: September 2 to October 29, 2019

Representative test engineer: *T. Yamada*
Toshinori Yamada
Engineer
Consumer Technology Division

Approved by: *K. Takeyama*
Kazutaka Takeyama
Engineer
Consumer Technology Division



CERTIFICATE 1266.03

- The testing in which "Non-accreditation" is displayed is outside the accreditation scopes in UL Japan.
 There is no testing item of "Non-accreditation".

UL Japan, Inc.
Shonan EMC Lab.

1-22-3 Megumigaoka, Hiratsuka-shi, Kanagawa-ken, 259-1220 JAPAN
Telephone : +81 463 50 6400
Facsimile : +81 463 50 6401

REVISION HISTORY

Original Test Report No.: 12851267S-A

Revision	Test report No.	Date	Page revised	Contents
- (Original)	12851267S-A	October 30, 2019	-	-
1	12851267S-A-R1	November 12, 2019	6	Correction of Test Procedure in 3.2: “KDB 558074 D01 15.247 Meas Guidance v05” to “KDB 558074 D01 15.247 Meas Guidance v05r02”
			9	Correction of Model No. of BLE Hybrid Watch: “YF05MV-01 *1), YF0MV *2)” to “YF05MV-01”
			17	Deletion of unnecessary comment: “The average output power was measured with the lowest order modulation and lowest data rate configuration in each IEEE 802.11 mode based on KDB 248227 D01.”

UL Japan, Inc.

Shonan EMC Lab.

1-22-3 Megumigaoka, Hiratsuka-shi, Kanagawa-ken, 259-1220 JAPAN

Telephone : +81 463 50 6400

Facsimile : +81 463 50 6401

Reference: Abbreviations (Including words undescribed in this report)

A2LA	The American Association for Laboratory Accreditation	NS	No signal detect.
AC	Alternating Current	NSA	Normalized Site Attenuation
AFH	Adaptive Frequency Hopping	NVLAP	National Voluntary Laboratory Accreditation Program
AM	Amplitude Modulation	OBW	Occupied Band Width
Amp, AMP	Amplifier	OFDM	Orthogonal Frequency Division Multiplexing
ANSI	American National Standards Institute	P/M	Power meter
Ant, ANT	Antenna	PCB	Printed Circuit Board
AP	Access Point	PER	Packet Error Rate
Atten., ATT	Attenuator	PHY	Physical Layer
AV	Average	PK	Peak
BPSK	Binary Phase-Shift Keying	PN	Pseudo random Noise
BR	Bluetooth Basic Rate	PRBS	Pseudo-Random Bit Sequence
BT	Bluetooth	PSD	Power Spectral Density
BLE / BT LE	Bluetooth Low Energy	QAM	Quadrature Amplitude Modulation
BW	BandWidth	QP	Quasi-Peak
Cal Int	Calibration Interval	QPSK	Quadri-Phase Shift Keying
CCK	Complementary Code Keying	RBW	Resolution Band Width
Ch., CH	Channel	RDS	Radio Data System
CISPR	Comite International Special des Perturbations Radioelectriques	RE	Radio Equipment
CW	Continuous Wave	RF	Radio Frequency
DBPSK	Differential BPSK	RMS	Root Mean Square
DC	Direct Current	RSS	Radio Standards Specifications
DFS	Dynamic Frequency Selection	Rx	Receiving
DQPSK	Differential QPSK	SA, S/A	Spectrum Analyzer
DSSS	Direct Sequence Spread Spectrum	SG	Signal Generator
EDR	Enhanced Data Rate	SVSWR	Site-Voltage Standing Wave Ratio
EIRP, e.i.r.p.	Equivalent Isotropically Radiated Power	TR	Test Receiver
EMC	ElectroMagnetic Compatibility	Tx	Transmitting
EMI	ElectroMagnetic Interference	VBW	Video BandWidth
EN	European Norm	Vert.	Vertical
ERP, e.r.p.	Effective Radiated Power	WLAN	Wireless LAN
EU	European Union		
EUT	Equipment Under Test		
Fac.	Factor		
FCC	Federal Communications Commission		
FHSS	Frequency Hopping Spread Spectrum		
FM	Frequency Modulation		
Freq.	Frequency		
GFSK	Gaussian Frequency-Shift Keying		
GNSS	Global Navigation Satellite System		
GPS	Global Positioning System		
Hori.	Horizontal		
ICES	Interference-Causing Equipment Standard		
IEC	International Electrotechnical Commission		
IEEE	Institute of Electrical and Electronics Engineers		
IF	Intermediate Frequency		
ILAC	International Laboratory Accreditation Conference		
ISED	Innovation, Science and Economic Development Canada		
ISO	International Organization for Standardization		
JAB	Japan Accreditation Board		
LAN	Local Area Network		
LIMS	Laboratory Information Management System		
MCS	Modulation and Coding Scheme		
MRA	Mutual Recognition Arrangement		
NIST	National Institute of Standards and Technology		

UL Japan, Inc.

Shonan EMC Lab.

1-22-3 Megumigaoka, Hiratsuka-shi, Kanagawa-ken, 259-1220 JAPAN

Telephone : +81 463 50 6400

Facsimile : +81 463 50 6401

CONTENTS	PAGE
SECTION 1: Customer information.....	5
SECTION 2: Equipment under test (E.U.T.).....	5
SECTION 3: Test specification, procedures & results.....	6
SECTION 4: Operation of E.U.T. during testing.....	9
SECTION 5: Radiated Spurious Emission	10
SECTION 6: Antenna Terminal Conducted Tests.....	12
APPENDIX 1: Test data	13
6 dB Bandwidth and 99 % Occupied Bandwidth.....	13
Maximum Peak Output Power	16
Average Output Power	17
Radiated Spurious Emission	20
Conducted Spurious Emission	26
Power Density	27
APPENDIX 2: Test instruments	29
APPENDIX 3: Photographs of test setup	31
Radiated Spurious Emission	31
Pre-check of the Worst Case Position	32

SECTION 1: Customer information

Company Name : Citizen Watch Co., Ltd.
Address : 6-1-12, Tanashi-cho, nishi-tokyo-shi, Tokyo 188-8511, Japan
Telephone Number : +81-42-467-6218
Facsimile Number : +81-42-467-1549
Contact Person : Syunya Syohji

The information provided from the customer is as follows;

- Applicant, Type of Equipment, Model No., FCC ID on the cover and other relevant pages
- Operating/Test Mode(s) (Mode(s)) on all the relevant pages
- SECTION 1: Customer information
- SECTION 2: Equipment under test (E.U.T.)
- SECTION 4: Operation of E.U.T. during testing

* The laboratory is exempted from liability of any test results affected from the above information in SECTION 2 and 4.

SECTION 2: Equipment under test (E.U.T.)

2.1 Identification of E.U.T.

Type of Equipment : BLE Hybrid Watch
Model No. : YF05MV-01
Serial No. : Refer to SECTION 4.2
Rating : DC 3.0 V (Battery)
Receipt Date of Sample : August 23, 2019
(Information from test lab.)
Country of Mass-production : China
Condition of EUT : Production prototype
(Not for Sale: This sample is equivalent to mass-produced items.)
Modification of EUT : No Modification by the test lab.

2.2 Product Description

Model: YF05MV-01 (referred to as the EUT in this report) is a BLE Hybrid Watch.

Radio Specification

Equipment Type : Transceiver
Frequency of Operation : 2402 MHz - 2480 MHz
Type of Modulation : GFSK
Antenna Type : Loop Trace
Antenna Gain : -11.58 dBi
Clock frequency (Maximum) : 16 MHz

SECTION 3: Test specification, procedures & results

3.1 Test Specification

Test Specification : FCC Part 15 Subpart C
FCC Part 15 final revised on July 19, 2019 and effective August 19, 2019 except 15.258

Title : FCC 47 CFR Part 15 Radio Frequency Device Subpart C Intentional Radiators
Section 15.207 Conducted limits
Section 15.247 Operation within the bands 902-928 MHz, 2400-2483.5 MHz,
and 5725-5850 MHz

* Also the EUT complies with FCC Part 15 Subpart B.

3.2 Procedures and results

Item	Test Procedure	Specification	Worst margin	Results	Remarks
Conducted Emission	FCC: ANSI C63.10-2013 6. Standard test methods	FCC: Section 15.207	-	N/A	*1)
	ISED: RSS-Gen 8.8	ISED: RSS-Gen 8.8			
6dB Bandwidth	FCC: KDB 558074 D01 15.247 Meas Guidance v05r02 ISED: -	FCC: Section 15.247(a)(2) ISED: RSS-247 5.2(a)	See data.	Complied a)	Conducted
Maximum Peak Output Power	FCC: KDB 558074 D01 15.247 Meas Guidance v05r02 ISED: RSS-Gen 6.12	FCC: Section 15.247(b)(3) ISED: RSS-247 5.4(d)		Complied b)	Conducted
Power Density	FCC: KDB 558074 D01 15.247 Meas Guidance v05r02 ISED: -	FCC: Section 15.247(e) ISED: RSS-247 5.2(b)		Complied c)	Conducted
Spurious Emission Restricted Band Edges	FCC: KDB 558074 D01 15.247 Meas Guidance v05r02	FCC: Section 15.247(d)	4.8 dB 7206.000 MHz, AV, Horizontal Mode: Tx BT LE, 2402 MHz	Complied# d), e)	Conducted (below 30 MHz)/ Radiated (above 30 MHz) *2)
	ISED: RSS-Gen 6.13	ISED: RSS-247 5.5 RSS-Gen 8.9 RSS-Gen 8.10			
Note: UL Japan, Inc.'s EMI Work Procedures No. 13-EM-W0420 and 13-EM-W0422. *1) The test is not applicable since the EUT has no AC mains. *2) Radiated test was selected over 30 MHz based on section 15.247(d) and KDB 558074 D01 15.247 Meas Guidance v05r02_8.5 and 8.6. a) Refer to APPENDIX 1 (data of 6 dB Bandwidth and 99 % Occupied Bandwidth) b) Refer to APPENDIX 1 (data of Maximum Peak Output Power) c) Refer to APPENDIX 1 (data of Power Density) d) Refer to APPENDIX 1 (data of Conducted Spurious Emission) e) Refer to APPENDIX 1 (data of Radiated Spurious Emission) Symbols: Complied The data of this test item has enough margin, more than the measurement uncertainty. Complied# The data of this test item meets the limits unless the measurement uncertainty is taken into consideration.					

* In case any questions arise about test procedure, ANSI C63.10: 2013 is also referred.

FCC Part 15.31 (e)

The EUT provides stable voltage constantly to the wireless transmitter regardless of input voltage. Instead of a new battery, the EUT was supplied from PC via USB for the test. That does not affect the test result, therefore the EUT complies with the requirement.

FCC Part 15.203 Antenna requirement

It is impossible for end users to replace the antenna, because the antenna is mounted inside of the EUT. Therefore, the equipment complies with the antenna requirement.

UL Japan, Inc.

Shonan EMC Lab.

1-22-3 Megumigaoka, Hiratsuka-shi, Kanagawa-ken, 259-1220 JAPAN

Telephone : +81 463 50 6400

Facsimile : +81 463 50 6401

3.3 Addition to standard

Item	Test Procedure	Specification	Worst margin	Results	Remarks
99% Occupied Bandwidth	RSS-Gen 6.7	ISED: -	N/A	- a)	Conducted

Note: UL Japan, Inc.'s EMI Work Procedures No. 13-EM-W0420 and 13-EM-W0422.

a) Refer to APPENDIX 1 (data of 6 dB Bandwidth and 99 % Occupied Bandwidth)

Other than above, no addition, exclusion nor deviation has been made from the standard.

3.4 Uncertainty

There is no applicable rule of uncertainty in this applied standard. Therefore, the results are derived depending on whether or not laboratory uncertainty is applied.

The following uncertainties have been calculated to provide a confidence level of 95 % using a coverage factor $k=2$.

Shonan EMC Lab.

Item	Frequency range	Uncertainty (+/-)			
		No. 1 SAC / SR	No. 2 SAC / SR	No. 3 SAC / SR	No. 4 SAC / SR
Conducted emission (AC Mains) LISN	150 kHz-30 MHz	2.9 dB	2.8 dB	2.9 dB	2.9 dB
Radiated emission (Measurement distance: 3 m)	9 kHz-30 MHz	3.0 dB	3.0 dB	3.1 dB	-
	30 MHz-200 MHz	4.6 dB	4.6 dB	4.7 dB	-
	200 MHz-1 GHz	6.0 dB	6.0 dB	6.1 dB	-
	1 GHz-6 GHz	4.8 dB	4.8 dB	4.8 dB	-
	6 GHz-18 GHz	5.4 dB	5.4 dB	5.4 dB	-
Radiated emission (Measurement distance: 1 m)	18 GHz-40 GHz	5.6 dB	5.6 dB	5.6 dB	-
	1 GHz-18 GHz	5.7 dB	5.7 dB	5.7 dB	-
	18 GHz-40 GHz	5.9 dB	5.9 dB	5.9 dB	-

SAC=Semi-Anechoic Chamber

SR= Shielded Room is applied besides radiated emission

Antenna terminal test	Uncertainty (+/-)
Power Measurement above 1 GHz (Average Detector)_SPM-06	0.81 dB
Power Measurement above 1 GHz (Peak Detector)_SPM-06	1.53 dB
Power Measurement above 1 GHz (Average Detector)_SPM-07	0.95 dB
Power Measurement above 1 GHz (Peak Detector)_SPM-07	1.21 dB
Power Measurement above 1 GHz (Average Detector)_SPM-13	0.90 dB
Power Measurement above 1 GHz (Peak Detector)_SPM-13	1.04 dB
Spurious emission (Conducted) below 1GHz	1.8 dB
Spurious emission (Conducted) 1 GHz-3 GHz	1.7 dB
Spurious emission (Conducted) 3 GHz-18 GHz	2.3 dB
Spurious emission (Conducted) 18 GHz-26.5 GHz	2.4 dB
Spurious emission (Conducted) 26.5 GHz-40 GHz	2.4 dB
Bandwidth Measurement	0.61 %
Duty cycle and Time Measurement	0.012 %

UL Japan, Inc.

Shonan EMC Lab.

1-22-3 Megumigaoka, Hiratsuka-shi, Kanagawa-ken, 259-1220 JAPAN

Telephone : +81 463 50 6400

Facsimile : +81 463 50 6401

3.5 Test Location

UL Japan, Inc. Shonan EMC Lab.

1-22-3, Megumigaoka, Hiratsuka-shi, Kanagawa-ken 259-1220 JAPAN

Telephone: +81 463 50 6400, Facsimile: +81 463 50 6401

A2LA Certificate Number: 1266.03 (FCC Test Firm Registration Number: 626366, ISED Lab Company Number: 2973D)

Test site	Width x Depth x Height (m)	Size of reference ground plane (m) / horizontal conducting plane	Maximum measurement distance
No.1 Semi-anechoic chamber	20.6 x 11.3 x 7.65	20.6 x 11.3	10 m
No.2 Semi-anechoic chamber	20.6 x 11.3 x 7.65	20.6 x 11.3	10 m
No.3 Semi-anechoic chamber	12.7 x 7.7 x 5.35	12.7 x 7.7	5 m
No.4 Semi-anechoic chamber	8.1 x 5.1 x 3.55	8.1 x 5.1	-
No.1 Shielded room	6.8 x 4.1 x 2.7	6.8 x 4.1	-
No.2 Shielded room	6.8 x 4.1 x 2.7	6.8 x 4.1	-
No.3 Shielded room	6.3 x 4.7 x 2.7	6.3 x 4.7	-
No.4 Shielded room	4.4 x 4.7 x 2.7	4.4 x 4.7	-
No.5 Shielded room	7.8 x 6.4 x 2.7	7.8 x 6.4	-
No.6 Shielded room	7.8 x 6.4 x 2.7	7.8 x 6.4	-
No.8 shielded room	3.45 x 5.5 x 2.4	3.45 x 5.5	-
No.1 Measurement room	2.55 x 4.1 x 2.5	-	-

3.6 Test data, Test instruments, and Test set up

Refer to APPENDIX.

UL Japan, Inc.

Shonan EMC Lab.

1-22-3 Megumigaoka, Hiratsuka-shi, Kanagawa-ken, 259-1220 JAPAN

Telephone : +81 463 50 6400

Facsimile : +81 463 50 6401

SECTION 4: Operation of E.U.T. during testing

4.1 Operating Mode(s)

Mode	Tested frequency	Remarks*
Tx, Bluetooth Low Energy	2402 MHz 2440 MHz 2480 MHz	Maximum Packet Size, PRBS9
*Power of the EUT was set by the software as follows; Power settings: Fixed Software: Connection Manager Ver.3.0/10 *This setting of software is the worst case. Any conditions under the normal use do not exceed the condition of setting. In addition, end users cannot change the settings of the output power of the product.		

4.2 Configuration and peripherals

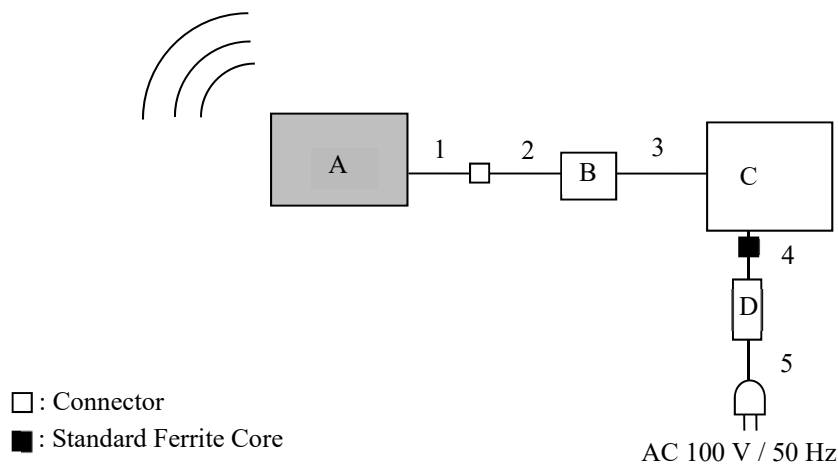

* Cabling and setup(s) were taken into consideration and test data was taken under worse case conditions.

No.	Item	Model number	Serial number	Manufacturer	Remarks
A	BLE Hybrid Watch	YF05MV-01	W1U0000107 *1) W00060P4FE *2)	CITIZEN WATCH CO., LTD.	EUT
B	Development Kit	-	-	-	-
C	Laptop Computer	Latitude E5500	0DW634	DELL	-
D	AC Adapter	HA90PE0-00	0W529	DELL	-

*1) Used for Radiated Emission tests

*2) Used for Antenna Terminal Conducted tests

List of cables used

No.	Name	Length (m)	Shield		Remarks
			Cable	Connector	
1	Signal	0.1	Unshielded	Unshielded	*3)
2	Signal	0.1	Unshielded	Unshielded	-
3	USB	1.0	Shielded	Shielded	-
4	DC	1.7	Unshielded	Unshielded	-
5	AC	0.9	Unshielded	Unshielded	-

*3) Cable for test operation

UL Japan, Inc.

Shonan EMC Lab.

1-22-3 Megumigaoka, Hiratsuka-shi, Kanagawa-ken, 259-1220 JAPAN

Telephone : +81 463 50 6400

Facsimile : +81 463 50 6401

SECTION 5: Radiated Spurious Emission

Test Procedure

It was measured based on "8.5 and 8.6 of KDB 558074 D01 15.247 Meas Guidance v05r02".

[For below 1 GHz]

EUT was placed on a platform of nominal size, 1.0 m by 2.0 m, raised 0.8 m above the conducting ground plane. The table is made of expanded polystyrol and expanded polypropylene and the table top is covered with polycarbonate. That has very low permittivity. The Radiated Electric Field Strength has been measured in a Semi Anechoic Chamber with a ground plane.

[For above 1 GHz]

EUT was placed on a urethane platform of nominal size, 0.5 m by 0.5 m, raised 1.5 m above the conducting ground plane. The Radiated Electric Field Strength has been measured in a Semi Anechoic Chamber with absorbent materials lined on a ground plane.

The height of the measuring antenna varied between 1 m and 4 m and EUT was rotated a full revolution in order to obtain the maximum value of the electric field strength.

Test antenna was aimed at the EUT for receiving the maximum signal and always kept within the illumination area of the 3 dB beamwidth of the antenna.

The measurements were performed for both vertical and horizontal antenna polarization with the Test Receiver, or the Spectrum Analyzer.

The measurements were made with the following detector function of the test receiver and the Spectrum analyzer (in linear mode).

The test was made with the detector (RBW/VBW) in the following table.

When using Spectrum analyzer, the test was made with adjusting span to zero by using peak hold.

Test Antennas are used as below;

Frequency	30 MHz to 200 MHz	200 MHz to 1 GHz	Above 1 GHz
Antenna Type	Biconical	Logperiodic	Horn

In any 100 kHz bandwidth outside the restricted band in which the spread spectrum intentional radiator is operating, the radio frequency power that is produced by the intentional radiator confirmed 20 dB below that in the 100 kHz bandwidth within the band that contains the highest level of the desired power, based on a radiated measurement.

20 dBc was applied to the frequency over the limit of FCC 15.209 / Table 4 of RSS-Gen 8.9(ISED) and outside the restricted band of FCC15.205 / Table 6 of RSS-Gen 8.10 (ISED).

Frequency	30 MHz to 1 GHz	Above 1 GHz		20 dBc
Instrument used	Test Receiver	Spectrum Analyzer		Spectrum Analyzer
Detector	QP	PK	AV *1)	PK
IF Bandwidth	BW 120 kHz	RBW: 1 MHz VBW: 3 MHz	11.12.2.5.2 RBW: 1 MHz VBW: 3 MHz Detector: Power Averaging (Linear voltage) Trace: 100 traces Duty factor was added to the results.	RBW: 100 kHz VBW: 300 kHz

*1) Average Power Measurement was performed based on ANSI C63.10-2013.

UL Japan, Inc.

Shonan EMC Lab.

1-22-3 Megumigaoka, Hiratsuka-shi, Kanagawa-ken, 259-1220 JAPAN

Telephone : +81 463 50 6400

Facsimile : +81 463 50 6401

Figure 1: Test Setup

Below 1 GHz

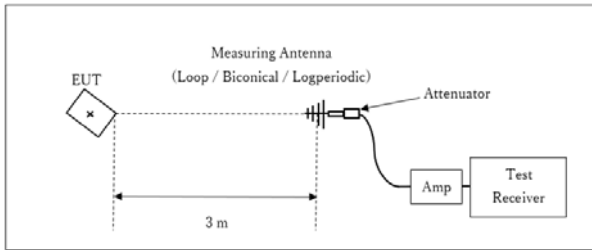

× : Center of turn table

Test Distance: 3 m

1 GHz - 13 GHz

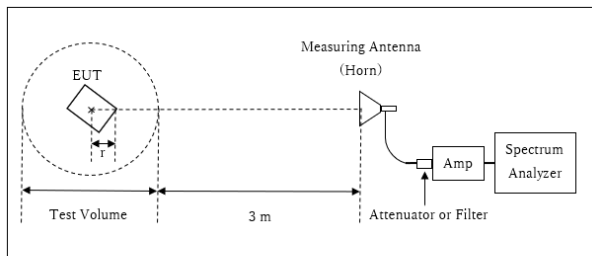

r : Radius of an outer periphery of EUT

× : Center of turn table

Distance Factor: $20 \times \log(3.965 \text{ m} / 3.0 \text{ m}) = 2.43 \text{ dB}$

* Test Distance: $(3 + \text{Test Volume} / 2) - r = 3.965 \text{ m}$

Test Volume : 2.0 m

(Test Volume has been calibrated based on CISPR 16-1-4.)

$r = 0.035 \text{ m}$

13 GHz – 26.5 GHz

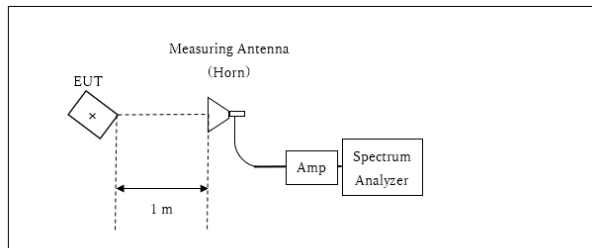

× : Center of turn table

Distance Factor: $20 \times \log(1.0 \text{ m} / 3.0 \text{ m}) = -9.54 \text{ dB}$

*Test Distance: 1 m

The carrier level and noise levels were confirmed at each position of X, Y and Z axes of EUT to see the position of maximum noise, and the test was made at the position that has the maximum noise.

Antenna polarization	Carrier	Spurious (30 MHz - 1 GHz)	Spurious (1 GHz - 2.8 GHz)	Spurious (2.8 GHz - 13 GHz)	Spurious (13 GHz - 18 GHz)	Spurious (18 GHz - 26.5 GHz)
Horizontal	X	X	X	Z	X	X
Vertical	Y	X	Y	Y	X	X

The test results and limit are rounded off to one decimal place, so some differences might be observed.

Measurement range : 30 MHz - 26.5 GHz

Test data : APPENDIX

Test result : Pass

UL Japan, Inc.

Shonan EMC Lab.

1-22-3 Megumigaoka, Hiratsuka-shi, Kanagawa-ken, 259-1220 JAPAN

Telephone : +81 463 50 6400

Facsimile : +81 463 50 6401

SECTION 6: Antenna Terminal Conducted Tests

Test Procedure

The tests were made with below setting connected to the antenna port.

Test	Span	RBW	VBW	Sweep time	Detector	Trace	Instrument used
6dB Bandwidth	10 MHz	100 kHz	300 kHz	Auto	Peak	Max Hold	Spectrum Analyzer
99% Occupied Bandwidth *1)	Enough width to display emission skirts	1 to 5 % of OBW	Three times of RBW	Auto	Peak	Max Hold	Spectrum Analyzer
Maximum Peak Output Power	-	-	-	Auto	Peak/Average *2)	-	Power Meter (Sensor: 50 MHz BW)
Peak Power Density	1.5 times the 6dB Bandwidth	3 kHz	9.1 kHz	Auto	Peak	Max Hold	Spectrum Analyzer *3)
Conducted Spurious Emission *5)	9kHz to 150kHz	200 Hz	620 Hz	Auto	Peak	Max Hold	Spectrum Analyzer
	150kHz to 30MHz	10 kHz	30 kHz				
*1) Peak hold was applied as Worst-case measurement. *2) Reference data *3) Section 11.10.2 Method PKPSD (peak PSD) of "ANSI C63.10-2013". *5) In the frequency range below 30MHz, RBW was narrowed to separate the noise contents. Then, wide-band noise near the limit was checked separately, however the noise was not detected as shown in the chart. (9 kHz - 150 kHz: RBW = 200 Hz, 150 kHz - 30 MHz: RBW = 10 kHz)							

The test results and limit are rounded off to two decimals place, so some differences might be observed.
The equipment and cables were not used for factor 0 dB of the data sheets.

Test data : APPENDIX
Test result : Pass

APPENDIX 1: Test data

6 dB Bandwidth and 99 % Occupied Bandwidth

Report No. 12851267S-A-R1
Test place Shonan EMC Lab. No.3 Shielded Room
Date October 29, 2019
Temperature / Humidity 23 deg. C / 47 % RH
Engineer Hiromasa Sato
Mode Tx BT LE

Mode	Frequency [MHz]	99% Occupied Bandwidth [kHz]	6dB Bandwidth [MHz]	Limit for 6dB Bandwidth [MHz]
BT LE	2402	1104.5	0.758	> 0.5000
	2440	1123.2	0.766	> 0.5000
	2480	1107.3	0.756	> 0.5000

99%Occupied Bandwidth

BT LE

2402 MHz

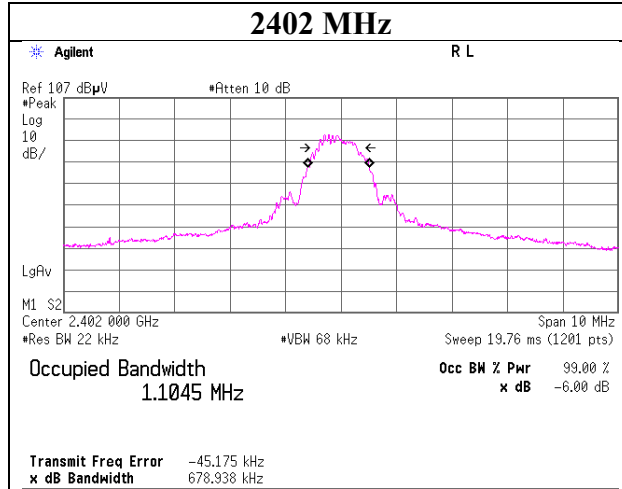

2440 MHz

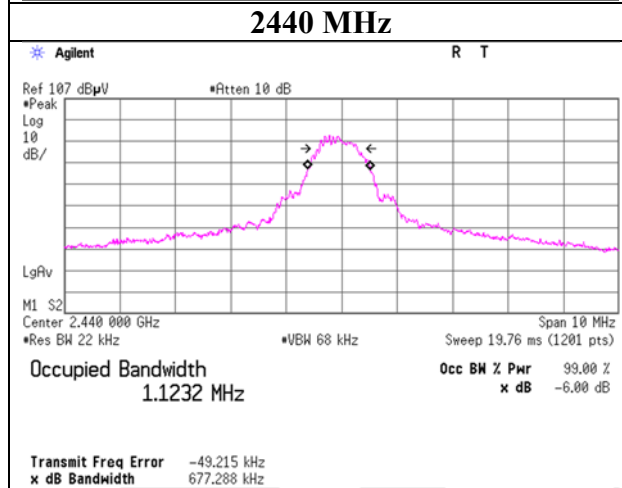

2480 MHz

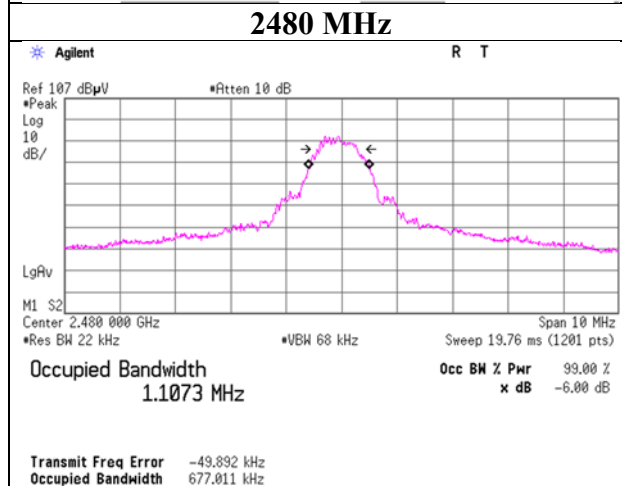

6dB Bandwidth

BT LE

2402 MHz

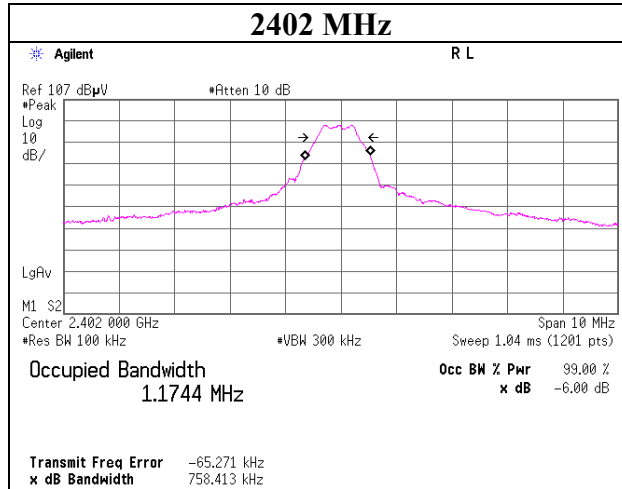

2440 MHz

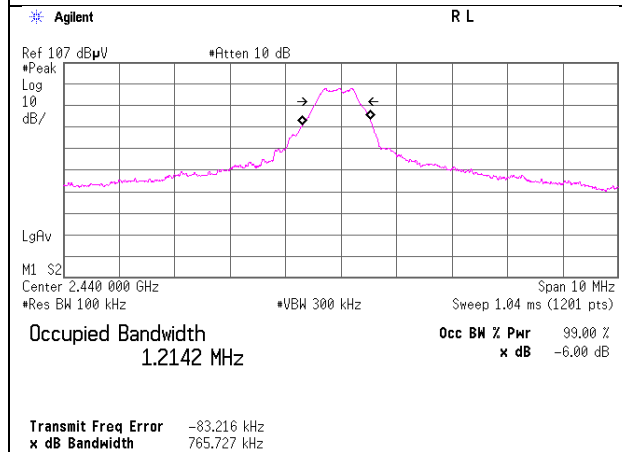

2480 MHz

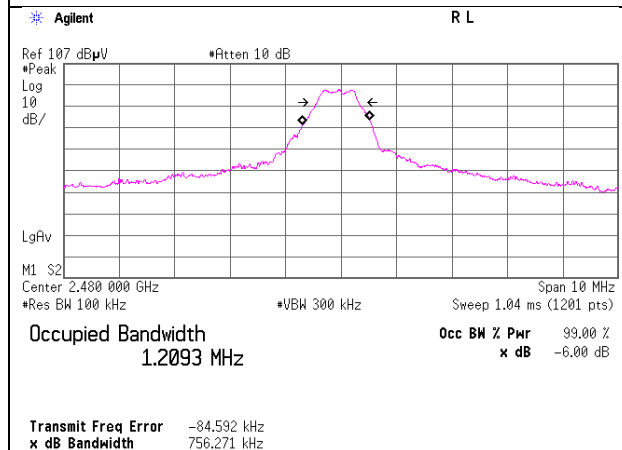

UL Japan, Inc.

Shonan EMC Lab.

1-22-3 Megumigaoka, Hiratsuka-shi, Kanagawa-ken, 259-1220 JAPAN

Telephone : +81 463 50 6400

Facsimile : +81 463 50 6401

Maximum Peak Output Power

Report No. 12851267S-A-R1
Test place Shonan EMC Lab. No.3 Shielded Room
Date October 29, 2019
Temperature / Humidity 23 deg. C / 47 % RH
Engineer Hiromasa Sato
Mode Tx BT LE

Freq. [MHz]	Reading [dBm]	Cable Loss [dB]	Atten. Loss [dB]	Conducted Power					e.i.r.p. for RSS-247					
				Result		Limit		Margin [dB]	Antenna Gain [dBi]	Result		Limit		Margin [dB]
				[dBm]	[mW]	[dBm]	[mW]			[dBm]	[mW]	[dBm]	[mW]	
2402	-11.43	1.28	9.82	-0.33	0.93	30.00	1000	30.33	-11.58	-11.91	0.06	36.02	4000	47.93
2440	-11.49	1.29	9.82	-0.38	0.92	30.00	1000	30.38	-11.58	-11.96	0.06	36.02	4000	47.98
2480	-11.78	1.30	9.82	-0.66	0.86	30.00	1000	30.66	-11.58	-12.24	0.06	36.02	4000	48.26

Sample Calculation:

Result = Reading + Cable Loss (including the cable(s) customer supplied) + Attenuator Loss

e.i.r.p. Result = Conducted Power Result + Antenna Gain

UL Japan, Inc.

Shonan EMC Lab.

1-22-3 Megumigaoka, Hiratsuka-shi, Kanagawa-ken, 259-1220 JAPAN

Telephone : +81 463 50 6400

Facsimile : +81 463 50 6401

Average Output Power
(Reference data for RF Exposure)

Report No. 12851267S-A-R1
Test place Shonan EMC Lab. No.3 Shielded Room
Date October 29, 2019
Temperature / Humidity 23 deg. C / 47 % RH
Engineer Hiromasa Sato
Mode Tx BT LE

BT LE

Freq. [MHz]	Reading [dBm]	Cable Loss [dB]	Atten. Loss [dB]	Result (Time average)		Duty factor [dB]	Result (Burst power average)	
				[dBm]	[mW]		[dBm]	[mW]
2402	-14.31	1.28	9.82	-3.21	0.48	2.03	-1.18	0.76
2440	-14.28	1.29	9.82	-3.17	0.48	2.03	-1.14	0.77
2480	-14.35	1.30	9.82	-3.23	0.48	2.03	-1.20	0.76

Sample Calculation:

Result (Time average) = Reading + Cable Loss (including the cable(s) customer supplied) + Attenuator Loss

Result (Burst power average) = Time average + Duty factor

Burst rate confirmation (for Average Output Power)

Report No. 12851267S-A-R1
 Test place Shonan EMC Lab. No.1 Semi Anechoic Chamber
 Date September 3, 2019
 Temperature / Humidity 24 deg. C / 51 % RH
 Engineer Hiromasa Sato
 Mode Tx BT LE

BT LE

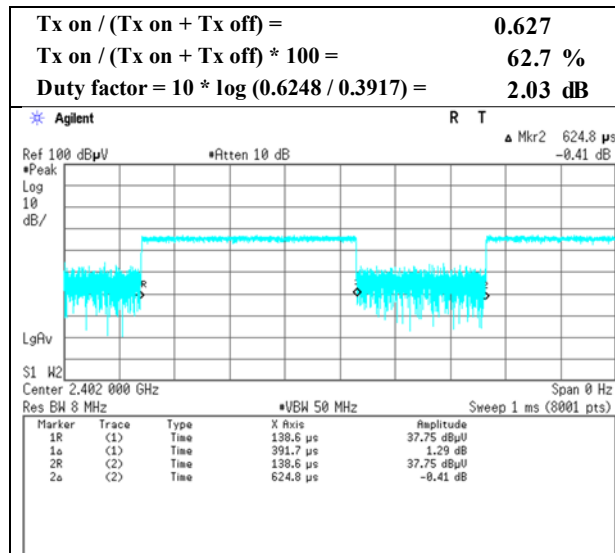

* Since the burst rate is not different between the channels, the data has been obtained on the representative channel.

Burst rate confirmation (for Radiated Spurious Emission)

Report No. 12851267S-A-R1
 Test place Shonan EMC Lab. No.1 Semi Anechoic Chamber
 Date September 3, 2019
 Temperature / Humidity 24 deg. C / 51 % RH
 Engineer Hiromasa Sato
 Mode Tx BT LE

BT LE

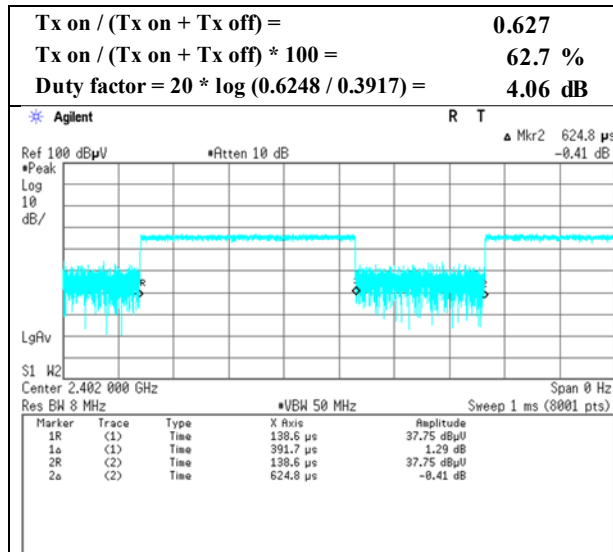

* Since the burst rate is not different between the channels, the data has been obtained on the representative channel.

Radiated Spurious Emission

Report No.	12851267S-A-R1	
Test place	Shonan EMC Lab.	
Semi Anechoic Chamber	No.1	No.1
Date	September 2, 2019	September 3, 2019
Temperature / Humidity	23 deg. C / 56 % RH	24 deg. C / 51 % RH
Engineer	Toshinori Yamada	Hiromasa Sato
	(30 MHz - 1000 MHz)	(1 GHz - 26.5 GHz)
Mode	Tx BT LE, 2402 MHz	

(* PK: Peak, AV: Average, QP: Quasi-Peak)

Polarity	Frequency [MHz]	Detector	Reading [dBuV]	Ant.Fac. [dB/m]	Loss [dB]	Gain [dB]	Distance Factor [dB]	Result [dBuV/m]	Limit [dBuV/m]	Margin [dB]	Height [cm]	Angle [deg]	Remark
Hori.	59.998	QP	42.50	8.20	7.27	31.84	0.00	26.13	40.0	13.8	363	215	
Hori.	133.197	QP	38.70	13.98	8.53	31.81	0.00	29.40	43.5	14.1	127	218	
Hori.	324.804	QP	39.80	14.39	7.45	31.77	0.00	29.87	46.0	16.1	100	233	
Hori.	420.798	QP	35.80	16.07	8.08	31.83	0.00	28.12	46.0	17.8	230	72	
Hori.	750.400	QP	25.50	20.17	9.20	31.93	0.00	22.94	46.0	23.0	100	112	
Hori.	914.462	QP	25.80	22.07	9.90	31.23	0.00	26.54	46.0	19.4	100	133	
Hori.	987.945	QP	23.40	22.33	10.22	30.65	0.00	25.30	53.9	28.6	100	120	
Hori.	2390.000	PK	46.48	28.31	14.62	39.59	2.43	52.25	73.9	21.6	193	148	
Hori.	4804.000	PK	46.55	31.60	7.10	39.75	2.43	47.93	73.9	25.9	170	275	
Hori.	7206.000	PK	46.05	37.15	9.00	39.53	2.43	55.10	73.9	18.8	150	0	
Vert.	60.256	QP	45.10	8.17	7.27	31.84	0.00	28.70	40.0	11.3	100	158	
Vert.	586.041	QP	24.00	18.85	8.52	31.95	0.00	19.42	46.0	26.5	100	308	
Vert.	2390.000	PK	45.89	28.31	14.62	39.59	2.43	51.66	73.9	22.2	129	262	
Vert.	4804.000	PK	47.00	31.60	7.10	39.75	2.43	48.38	73.9	25.5	168	321	
Vert.	7206.000	PK	46.65	37.15	9.00	39.53	2.43	55.70	73.9	18.2	150	0	

Result = Reading + Ant.Fac. + Loss (Cable+(Attenuator or Filter)(below 18 GHz)) - Gain(Amplifier) + Distance factor

Distance factor : 1 GHz - 13 GHz : 20log(3.965 m / 3.0 m) = 2.43 dB

13 GHz - 40 GHz : 20log(1.0 m / 3.0 m) = -9.54 dB

Average measurement value with duty factor

Polarity	Frequency [MHz]	Detector	Reading [dBuV]	Ant.Fac. [dB/m]	Loss [dB]	Gain [dB]	Duty Factor [dB]	Distance Factor [dB]	Result [dBuV/m]	Limit [dBuV/m]	Margin [dB]	Remark
Hori.	2390.000	AV	36.07	28.31	14.62	39.59	4.06	2.43	45.90	53.9	8.0	*1)
Hori.	4804.000	AV	38.98	31.60	7.10	39.75	4.06	2.43	44.42	53.9	9.4	
Hori.	7206.000	AV	35.95	37.15	9.00	39.53	4.06	2.43	49.06	53.9	4.8	
Vert.	2390.000	AV	36.37	28.31	14.62	39.59	4.06	2.43	46.20	53.9	7.7	*1)
Vert.	4804.000	AV	38.80	31.60	7.10	39.75	4.06	2.43	44.24	53.9	9.6	
Vert.	7206.000	AV	35.47	37.15	9.00	39.53	4.06	2.43	48.58	53.9	5.3	

Result = Reading + Ant.Fac. + Loss (Cable+(Attenuator or Filter)(below 18 GHz)) - Gain(Amplifier) + Duty factor + Distance factor

Distance factor : 1 GHz - 13 GHz : 20log(3.965 m / 3.0 m) = 2.43 dB

13 GHz - 40 GHz : 20log(1.0 m / 3.0 m) = -9.54 dB

Duty factor refer to "Duty factor Calculation chart" sheet.

*1) Not out of band emission (Leakage Power)

20 dBc Data Sheet (RBW 100 kHz, VBW 300 kHz)

Polarity	Frequency [MHz]	Detector	Reading [dBuV]	Ant.Fac. [dB/m]	Loss [dB]	Gain [dB]	Distance Factor [dB]	Result [dBuV/m]	Limit [dBuV/m]	Margin [dB]	Remark
Hori.	2402.000	PK	75.56	28.28	14.63	39.59	2.43	81.31	-	-	Carrier
Hori.	2400.000	PK	41.91	28.29	14.63	39.59	2.43	47.67	61.3	13.6	
Vert.	2402.000	PK	76.29	28.28	14.63	39.59	2.43	82.04	-	-	Carrier
Vert.	2400.000	PK	41.03	28.29	14.63	39.59	2.43	46.79	62.0	15.2	

Result = Reading + Ant.Fac. + Loss (Cable+(Attenuator or Filter)(below 18 GHz)) - Gain(Amplifier) + Distance factor

Distance factor : 1 GHz - 13 GHz : 20log(3.965 m / 3.0 m) = 2.43 dB

13 GHz - 40 GHz : 20log(1.0 m / 3.0 m) = -9.54 dB

UL Japan, Inc.

Shonan EMC Lab.

1-22-3 Megumigaoka, Hiratsuka-shi, Kanagawa-ken, 259-1220 JAPAN

Telephone : +81 463 50 6400

Facsimile : +81 463 50 6401

Radiated Spurious Emission
(Reference Plot for band-edge)

Report No. 12851267S-A-R1
Test place Shonan EMC Lab.
Semi Anechoic Chamber No.1
Date September 3, 2019
Temperature / Humidity 24 deg. C / 51 % RH
Engineer Hiromasa Sato
(1 GHz – 26.5 GHz)
Mode Tx BT LE, 2402 MHz

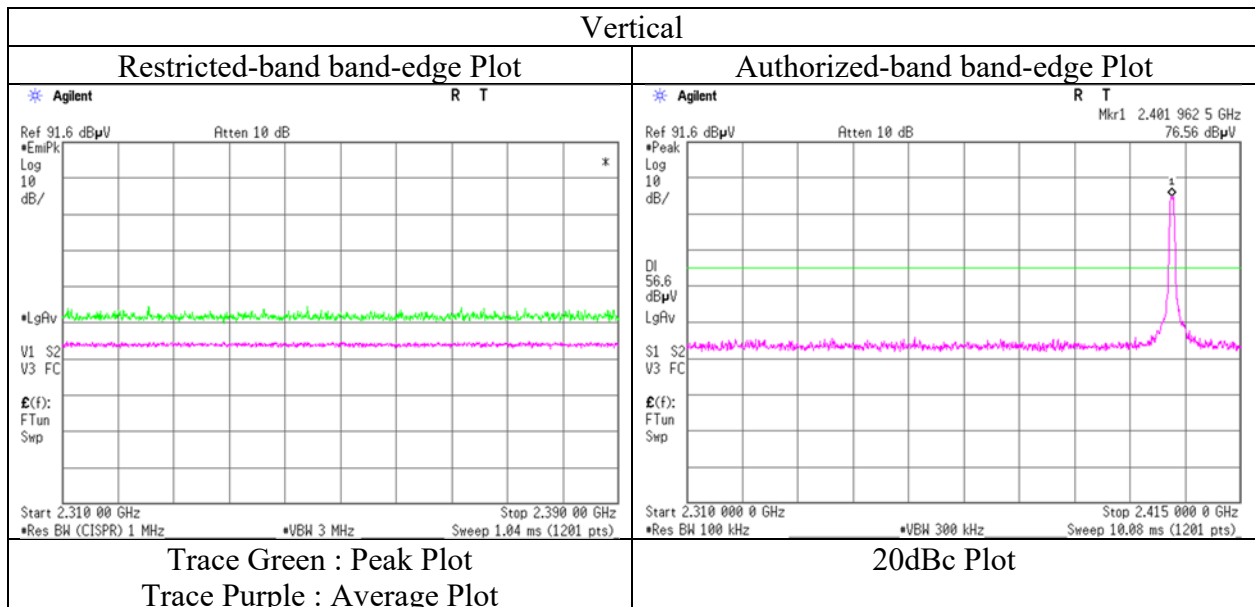
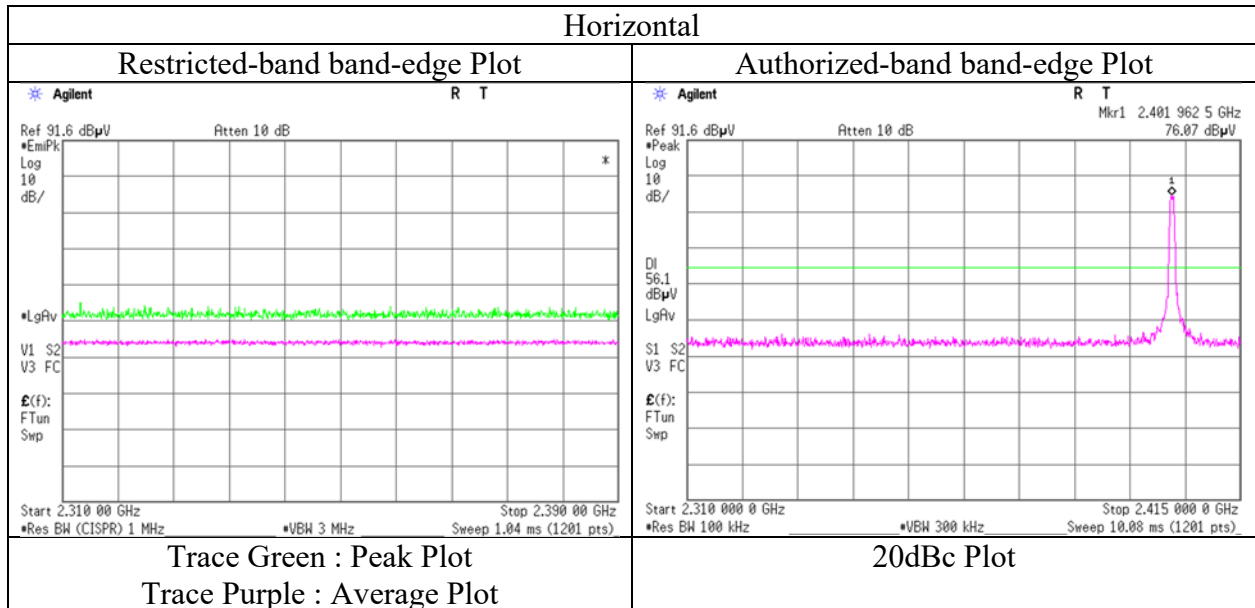

* The measurement was conducted for a sufficiently long enough time to detect any possible spurious emissions.
Final result of restricted band edge was shown in tabular data.

Radiated Spurious Emission

Report No.	12851267S-A-R1	
Test place	Shonan EMC Lab.	
Semi Anechoic Chamber	No.1	No.1
Date	September 2, 2019	September 3, 2019
Temperature / Humidity	23 deg. C / 56 % RH	24 deg. C / 51 % RH
Engineer	Toshinori Yamada	Hiromasa Sato
	(30 MHz - 1000 MHz)	(1 GHz - 26.5 GHz)
Mode	Tx BT LE, 2440 MHz	

(* PK: Peak, AV: Average, QP: Quasi-Peak)

Polarity	Frequency [MHz]	Detector	Reading [dBuV]	Ant.Fac. [dB/m]	Loss [dB]	Gain [dB]	Distance Factor [dB]	Result [dBuV/m]	Limit [dBuV/m]	Margin [dB]	Height [cm]	Angle [deg]	Remark
Hori.	60.200	QP	42.20	8.18	7.28	31.84	0.00	25.82	40.0	14.1	356	208	
Hori.	133.193	QP	40.00	13.98	8.53	31.81	0.00	30.70	43.5	12.8	136	212	
Hori.	324.746	QP	39.00	14.39	7.45	31.77	0.00	29.07	46.0	16.9	100	243	
Hori.	420.796	QP	33.70	16.07	8.08	31.83	0.00	26.02	46.0	19.9	241	77	
Hori.	750.569	QP	27.60	20.17	9.20	31.93	0.00	25.04	46.0	20.9	100	98	
Hori.	914.460	QP	26.20	22.07	9.90	31.23	0.00	26.94	46.0	19.0	100	122	
Hori.	986.835	QP	23.00	22.32	10.22	30.66	0.00	24.88	53.9	29.0	100	120	
Hori.	4880.000	PK	47.13	31.66	7.14	39.74	2.43	48.62	73.9	25.2	151	281	
Hori.	7320.000	PK	44.50	37.24	9.03	39.60	2.43	53.60	73.9	20.3	150	0	
Vert.	60.194	QP	45.40	8.18	7.28	31.84	0.00	29.02	40.0	10.9	100	155	
Vert.	586.041	QP	24.20	18.85	8.52	31.95	0.00	19.62	46.0	26.3	100	302	
Vert.	4880.000	PK	46.63	31.66	7.14	39.74	2.43	48.12	73.9	25.7	185	147	
Vert.	7320.000	PK	44.28	37.24	9.03	39.60	2.43	53.38	73.9	20.5	156	78	

Result = Reading + Ant.Fac. + Loss (Cable+(Attenuator or Filter)(below 18 GHz)) - Gain(Amplifier) + Distance factor

Distance factor : 1 GHz - 13 GHz : 20log(3.965 m / 3.0 m) = 2.43 dB

13 GHz - 40 GHz : 20log(1.0 m / 3.0 m) = -9.54 dB

Average measurement value with duty factor

Polarity	Frequency [MHz]	Detector	Reading [dBuV]	Ant.Fac. [dB/m]	Loss [dB]	Gain [dB]	Duty Factor [dB]	Distance Factor [dB]	Result [dBuV/m]	Limit [dBuV/m]	Margin [dB]	Remark
Hori.	4880.000	AV	38.64	31.66	7.14	39.74	4.06	2.43	44.19	53.9	9.7	
Hori.	7320.000	AV	35.13	37.24	9.03	39.60	4.06	2.43	48.29	53.9	5.6	
Vert.	4880.000	AV	38.11	31.66	7.14	39.74	4.06	2.43	43.66	53.9	10.2	
Vert.	7320.000	AV	35.39	37.24	9.03	39.60	4.06	2.43	48.55	53.9	5.3	

Result = Reading + Ant.Fac. + Loss (Cable+(Attenuator or Filter)(below 18 GHz)) - Gain(Amplifier) + Duty factor + Distance factor

Distance factor : 1 GHz - 13 GHz : 20log(3.965 m / 3.0 m) = 2.43 dB

13 GHz - 40 GHz : 20log(1.0 m / 3.0 m) = -9.54 dB

Duty factor refer to "Duty factor Calculation chart" sheet.

*1) Not out of band emission (Leakage Power)

Radiated Spurious Emission

Report No.	12851267S-A-R1	
Test place	Shonan EMC Lab.	
Semi Anechoic Chamber	No.1	No.1
Date	September 2, 2019	September 3, 2019
Temperature / Humidity	23 deg. C / 56 % RH	24 deg. C / 51 % RH
Engineer	Toshinori Yamada	Hiromasa Sato
	(30 MHz - 1000 MHz)	(1 GHz - 26.5 GHz)
Mode	Tx BT LE, 2480 MHz	

(* PK: Peak, AV: Average, QP: Quasi-Peak)

Polarity	Frequency [MHz]	Detector	Reading [dBuV]	Ant.Fac. [dB/m]	Loss [dB]	Gain [dB]	Distance Factor [dB]	Result [dBuV/m]	Limit [dBuV/m]	Margin [dB]	Height [cm]	Angle [deg]	Remark
Hori.	59.992	QP	42.90	8.20	7.27	31.84	0.00	26.53	40.0	13.4	336	211	
Hori.	133.194	QP	40.10	13.98	8.53	31.81	0.00	30.80	43.5	12.7	137	203	
Hori.	324.855	QP	39.30	14.39	7.45	31.77	0.00	29.37	46.0	16.6	100	223	
Hori.	420.780	QP	33.50	16.07	8.08	31.83	0.00	25.82	46.0	20.1	253	72	
Hori.	750.627	QP	25.90	20.18	9.20	31.93	0.00	23.35	46.0	22.6	100	99	
Hori.	914.453	QP	24.40	22.07	9.90	31.23	0.00	25.14	46.0	20.8	100	151	
Hori.	987.976	QP	22.30	22.33	10.22	30.65	0.00	24.20	53.9	29.7	100	123	
Hori.	2483.500	PK	54.43	28.16	14.71	39.62	2.43	60.11	73.9	13.7	241	142	
Hori.	4960.000	PK	47.06	31.83	7.18	39.72	2.43	48.78	73.9	25.1	148	272	
Hori.	7440.000	PK	44.39	37.38	9.04	39.68	2.43	53.56	73.9	20.3	150	0	
Vert.	59.963	QP	45.30	8.21	7.27	31.84	0.00	28.94	40.0	11.0	100	154	
Vert.	586.041	QP	23.70	18.85	8.52	31.95	0.00	19.12	46.0	26.8	100	302	
Vert.	2483.500	PK	53.04	28.16	14.71	39.62	2.43	58.72	73.9	15.1	126	263	
Vert.	4960.000	PK	45.79	31.83	7.18	39.72	2.43	47.51	73.9	26.3	129	153	
Vert.	7440.000	PK	43.73	37.38	9.04	39.68	2.43	52.90	73.9	21.0	150	0	

Result = Reading + Ant.Fac. + Loss (Cable+(Attenuator or Filter)(below 18 GHz)) - Gain(Amplifier) + Distance factor

Distance factor : 1 GHz - 13 GHz : 20log(3.965 m / 3.0 m) = 2.43 dB

13 GHz - 40 GHz : 20log(1.0 m / 3.0 m) = -9.54 dB

Average measurement value with duty factor

Polarity	Frequency [MHz]	Detector	Reading [dBuV]	Ant.Fac. [dB/m]	Loss [dB]	Gain [dB]	Duty Factor [dB]	Distance Factor [dB]	Result [dBuV/m]	Limit [dBuV/m]	Margin [dB]	Remark
Hori.	2483.500	AV	37.02	28.16	14.71	39.62	4.06	2.43	46.76	53.9	7.1	*1)
Hori.	4960.000	AV	37.88	31.83	7.18	39.72	4.06	2.43	43.66	53.9	10.2	
Hori.	7440.000	AV	35.50	37.38	9.04	39.68	4.06	2.43	48.73	53.9	5.1	
Vert.	2483.500	AV	36.77	28.16	14.71	39.62	4.06	2.43	46.51	53.9	7.3	*1)
Vert.	4960.000	AV	37.43	31.83	7.18	39.72	4.06	2.43	43.21	53.9	10.6	
Vert.	7440.000	AV	35.55	37.38	9.04	39.68	4.06	2.43	48.78	53.9	5.1	

Result = Reading + Ant.Fac. + Loss (Cable+(Attenuator or Filter)(below 18 GHz)) - Gain(Amplifier) + Duty factor + Distance factor

Distance factor : 1 GHz - 13 GHz : 20log(3.965 m / 3.0 m) = 2.43 dB

13 GHz - 40 GHz : 20log(1.0 m / 3.0 m) = -9.54 dB

Duty factor refer to "Duty factor Calculation chart" sheet.

*1) Not out of band emission (Leakage Power)

Radiated Spurious Emission
(Reference Plot for band-edge)

Report No. 12851267S-A-R1
Test place Shonan EMC Lab.
Semi Anechoic Chamber No.1
Date September 3, 2019
Temperature / Humidity 24 deg. C / 51 % RH
Engineer Hiromasa Sato
(1 GHz – 26.5 GHz)
Mode Tx BT LE, 2480 MHz

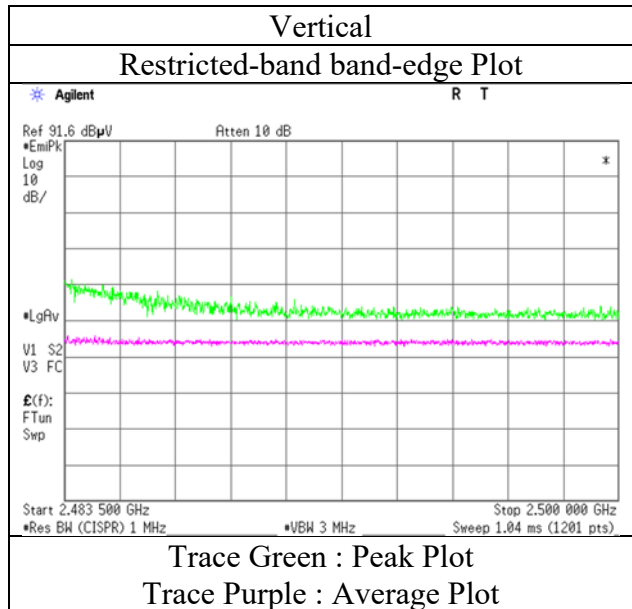
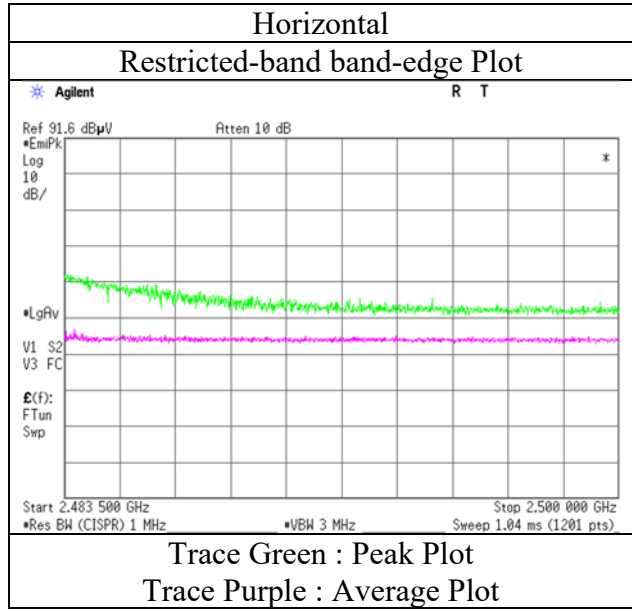

* The measurement was conducted for a sufficiently long enough time to detect any possible spurious emissions.
Final result of restricted band edge was shown in tabular data.

Radiated Spurious Emission
(Plot data, Worst case)

Report No.	12851267S-A-R1	
Test place	Shonan EMC Lab.	
Semi Anechoic Chamber	No.1	No.1
Date	September 2, 2019	September 3, 2019
Temperature / Humidity	23 deg. C / 56 % RH	24 deg. C / 51 % RH
Engineer	Toshinori Yamada	Hiromasa Sato
	(30 MHz - 1000 MHz)	(1 GHz - 26.5 GHz)
Mode	Tx BT LE, 2480 MHz	

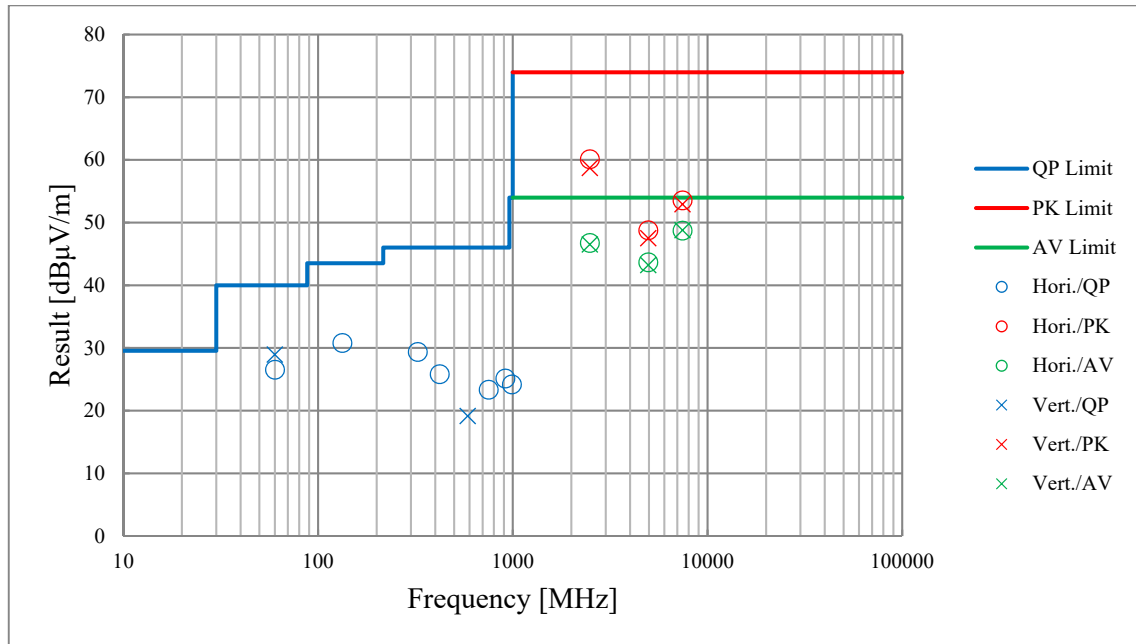

*These plots data contains sufficient number to show the trend of characteristic features for EUT.

Conducted Spurious Emission

Report No. 12851267S-A-R1
 Test place Shonan EMC Lab. No.3 Shielded Room
 Date October 29, 2019
 Temperature / Humidity 23 deg. C / 47 % RH
 Engineer Hiromasa Sato
 Mode Tx BT LE 2480 MHz

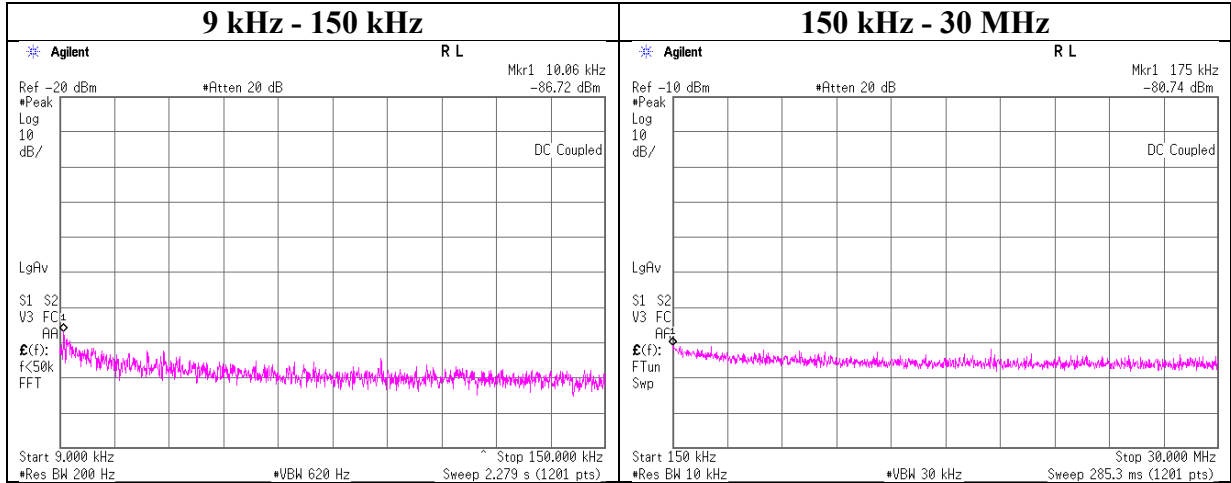

Frequency [kHz]	Reading [dBm]	Cable Loss [dB]	Attenuator Loss [dB]	Antenna Gain* [dBi]	N (Number of Output)	EIRP [dBm]	Distance [m]	Ground bounce [dB]	E (field strength) [dBuV/m]	Limit [dBuV/m]	Margin [dB]	Remark
10.06	-86.72	0.01	9.7	2.0	1	-75.0	300	6.0	-13.7	47.5	61.2	
175.00	-80.74	0.01	9.7	2.0	1	-69.0	300	6.0	-7.7	22.7	30.4	

$$E \text{ [dBuV/m]} = \text{EIRP [dBm]} - 20 \log(\text{Distance [m]}) + \text{Ground bounce [dB]} + 104.8 \text{ [dBuV/m]}$$

$$\text{EIRP [dBm]} = \text{Reading [dBm]} + \text{Cable loss [dB]} + \text{Attenuator Loss [dB]} + \text{Antenna gain [dBi]} + 10 * \log(N)$$

N: Number of output

*2.0 dBi was applied to the test result based on ANSI C63.10 since antenna gain was less than 2.0 dBi.

Power Density

Report No. 12851267S-A-R1
Test place Shonan EMC Lab. No.3 Shielded Room
Date October 29, 2019
Temperature / Humidity 23 deg. C / 47 % RH
Engineer Hiromasa Sato
Mode Tx BT LE

Freq. [MHz]	Reading [dBm]	Cable Loss [dB]	Atten. Loss [dB]	Result [dBm]	Limit [dBm]	Margin [dB]
2402	-26.15	1.28	9.82	-15.05	8.00	23.05
2440	-26.34	1.29	9.82	-15.23	8.00	23.23
2480	-26.66	1.30	9.82	-15.54	8.00	23.54

Sample Calculation:

Result = Reading + Cable Loss (including the cable(s) customer supplied) + Attenuator Loss

Power Density

BT LE

2402 MHz

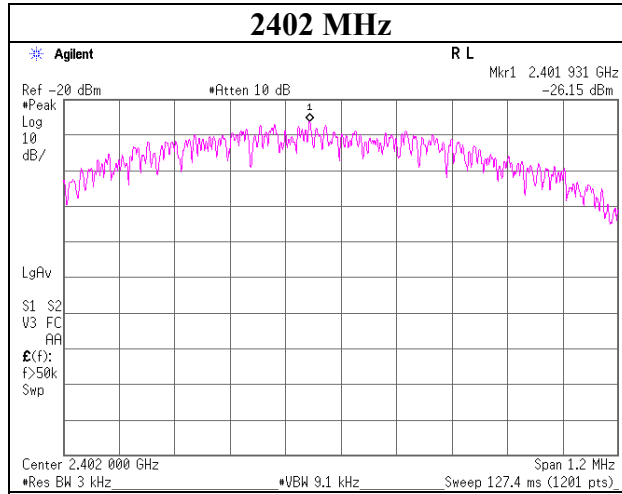

2440 MHz

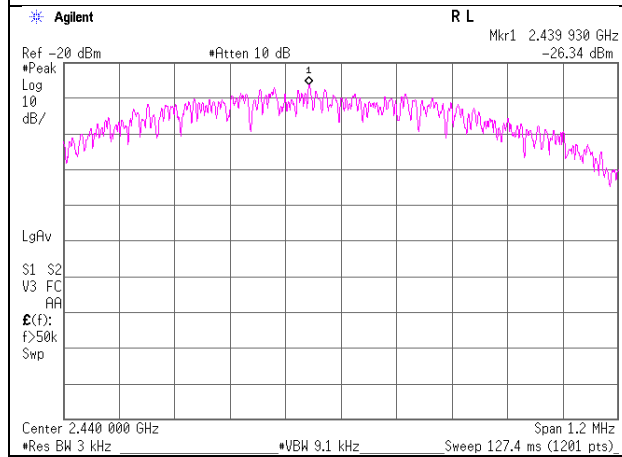

2480 MHz

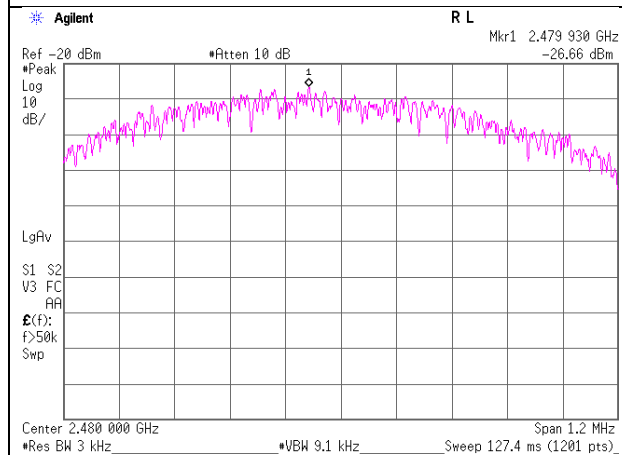

APPENDIX 2: Test instruments

Test Instruments (1 / 2)

Local ID	Test Name	LIMS ID	Description	Manufacturer	Model	Serial	Last Calibration Date	Calibration Due Date	Calibration Interval (Month)
SAT10-14	AT	154591	Attenuator	Weinschel Corp.	54A-10	81595	2019/4/16	2020/4/30	12
SCC-G12	AT	145040	Coaxial Cable	Suhner	SUCOFLEX 102	30790/2	2019/3/27	2020/3/31	12
SOS-06	AT	146294	Humidity Indicator	A&D	AD-5681	4062118	2018/12/5	2019/12/31	12
SPM-07	AT	146247	Power Meter	AGILENT	8990B	MY5100272	2019/7/16	2020/7/31	12
SPSS-04	AT	146310	Power sensor	AGILENT	N1923A	MY5326009	2019/7/16	2020/7/31	12
SRENT-15	AT	160899	Spectrum Analyzer	AGILENT (KEYSIGHT)	E4440A	MY46185516	2019/1/21	2020/1/31	12
COTS-SEMI-5	RE	170932	EMI Software	TSJ	TEPTO-DV3(RE,CE,ME,PE)	-	-	-	-
KAT6-04	RE	144899	Attenuator	Inmet	18N-6dB	-	2018/12/25	2019/12/31	12
KBA-01	RE	146343	Biconical Antenna	Schwarzbeck	BBA9106	1748	2019/6/5	2020/6/30	12
KJM-09	RE	145929	Measure	KOMELON	KMC-36	-	-	-	-
SAEC-01(NSA)	RE	145597	Semi-Anechoic Chamber	TDK	SAEC-01(NSA)	1	2019/4/2	2020/4/30	12
SAEC-01(SVSWR)	RE	145561	Semi-Anechoic Chamber	TDK	SAEC-01(SVSWR)	1	2019/5/6	2020/5/30	12
SAF-01	RE	145003	Pre Amplifier	SONOMA	310N	290211	2019/2/5	2020/2/29	12
SAF-04	RE	145127	Pre Amplifier	Toyo Corporation	TPA0118-36	2072554	2019/6/4	2020/6/30	12
SAF-08	RE	145007	Pre Amplifier	Toyo Corporation	HAP18-26W	19	2019/3/5	2020/3/31	12
SAT10-05	RE	145136	Attenuator(above1GHz)	AGILENT	8493C-010	74864	2018/11/25	2019/11/30	12
SAT3-09	RE	144959	Attenuator	JFW	50HF-003N	-	2019/8/6	2020/8/31	12

UL Japan, Inc.

Shonan EMC Lab.

1-22-3 Megumigaoka, Hiratsuka-shi, Kanagawa-ken, 259-1220 JAPAN

Telephone : +81 463 50 6400

Facsimile : +81 463 50 6401

Test Instruments (2/ 2)

Local ID	Test Name	LIMS ID	Description	Manufacturer	Model	Serial	Last Calibration Date	Calibration Due Date	Calibration Interval (Month)
SCC-A1/A3/A5/A7/A8/A13/SRSE-01	RE	144967	Coaxial Cable&RF Selector	Fujikura/Fujikura/Suhner/Suhner/TOYO	8D2W/12DSFA/141PE/141PE/141PE/141P	-/0901-269(RF Selector)	2019/4/19	2020/4/30	12
SCC-A2/A4/A6/A7/A8/A13/SRSE-01	RE	144968	Coaxial Cable&RF Selector	Fujikura/Fujikura/Suhner/Suhner/TOYO	8D2W/12DSFA/141PE/141PE/141PE/141P	-/0901-269(RF Selector)	2019/4/19	2020/4/30	12
SCC-G05	RE	145039	Coaxial Cable	Junkosha	J12J102207-00	APR-30-15-037	2019/1/25	2020/1/31	12
SCC-G15	RE	145176	Coaxial Cable	Suhner	SUCOFLEX 102	32703/2	2019/3/27	2020/3/31	12
SCC-G41	RE	151617	Coaxial Cable	Junkosha	MWX221-01000NFSN MS/B	1612S006	2019/1/25	2020/1/31	12
SCC-G56	RE	179539	Coaxial Cable	Huber+Suhner	SUCOFLEX 104	803289/4	2019/5/16	2020/5/31	12
SCC-G57	RE	179540	Coaxial Cable	Huber+Suhner	SUCOFLEX 102	802815/2	2019/5/16	2020/5/31	12
SFL-02	RE	145301	Highpass Filter	MICRO-TRONICS	HPM50111	51	2018/11/16	2019/11/30	12
SHA-01	RE	145383	Horn Antenna	Schwarzbeck	BBHA9120D	9120D-725	2019/5/9	2020/5/31	12
SHA-04	RE	145512	Horn Antenna	ETS LINDGREN	3160-09	94868	2019/6/26	2020/6/30	12
SLA-05	RE	145527	Logperiodic Antenna	Schwarzbeck	VUSLP9111B	193	2019/4/1	2020/4/30	12
SOS-01	RE	146316	Humidity Indicator	A&D	AD-5681	4062555	2018/10/25	2019/10/31	12
SSA-02	RE	145800	Spectrum Analyzer	AGILENT	E4448A	MY48250106	2019/4/4	2020/4/30	12
STR-01	RE	145790	Test Receiver	Rohde & Schwarz	ESU40	100093	2019/4/14	2020/4/30	12
STS-01	RE	145792	Digital Hitester	HIOKI	3805-50	80997812	2019/10/1	2020/10/31	12

*Hyphens for Last Calibration Date, Calibration Due Date and Cal Int (month) are instruments that Calibration is not required (e.g. software), or instruments checked in advance before use.

The expiration date of the calibration is the end of the expired month.
All equipment is calibrated with valid calibrations. Each measurement data is traceable to the national or international standards.

As for some calibrations performed after the tested dates, those test equipment have been controlled by means of an unbroken chains of calibrations.

Test item: RE: Radiated Emission test
AT: Antenna terminal conducted test