

FCC Test Report

Report No.: RFCBVX-WTW-P22051015A

FCC ID: YUQ-P991MV01

Test Model: P991MV-01, P991MV-02 (refer to item 3.1 for more details)

Received Date: Sep. 20, 2022

Test Date: Oct. 08, 2022

Issued Date: Nov. 10, 2022

Applicant: Citizen Watch CO., LTD.

Address: 6-1-12 TANASHICHO, NISHITOKYO-SHI, TOKYO 188--8511, JAPAN

Issued By: Bureau Veritas Consumer Products Services (H.K.) Ltd., Taoyuan Branch
Lin Kou Laboratories

Lab Address: No. 47-2, 14th Ling, Chia Pau Vil., Lin Kou Dist., New Taipei City, Taiwan

Test Location: No.19, Hwa Ya 2nd Rd., Wen Hwa Vil., Kwei Shan Dist., Taoyuan City
33383, Taiwan

**FCC Registration /
Designation Number:** 788550 / TW0003



This report is governed by, and incorporates by reference, the Conditions of Testing as posted at the date of issuance of this report at <http://www.bureauveritas.com/home/about-us/our-business/cps/about-us/terms-conditions/> and is intended for your exclusive use. Any copying or replication of this report to or for any other person or entity, or use of our name or trademark, is permitted only with our prior written permission. This report sets forth our findings solely with respect to the test samples identified herein. The results set forth in this report are not indicative or representative of the quality or characteristics of the lot from which a test sample was taken or any similar or identical product unless specifically and expressly noted. Our report includes all of the tests requested by you and the results thereof based upon the information that you provided to us. Measurement uncertainty is only provided upon request for accredited tests. Statements of conformity are based on simple acceptance criteria without taking measurement uncertainty into account, unless otherwise requested in writing. You have 60 days from date of issuance of this report to notify us of any material error or omission caused by our negligence or if you require measurement uncertainty; provided, however, that such notice shall be in writing and shall specifically address the issue you wish to raise. A failure to raise such issue within the prescribed time shall constitute your unqualified acceptance of the completeness of this report, the tests conducted and the correctness of the report contents.

Table of Contents

Release Control Record	3
1 Certificate of Conformity	4
2 Summary of Test Results.....	5
2.1 Measurement Uncertainty.....	6
2.2 Modification Record	6
3 General Information	7
3.1 General Description of EUT	7
3.2 Description of Test Modes.....	8
3.2.1 Test Mode Applicability and Tested Channel Detail.....	9
3.3 Duty Cycle of Test Signal	10
3.4 Description of Support Units	10
3.4.1 Configuration of System under Test	11
3.5 General Description of Applied Standards and References	12
4 Test Types and Results	13
4.1 Radiated Emission and Bandedge Measurement	13
4.1.1 Limits of Radiated Emission and Bandedge Measurement	13
4.1.2 Test Instruments	14
4.1.3 Test Procedures.....	15
4.1.4 Deviation from Test Standard	16
4.1.5 Test Set Up	16
4.1.6 EUT Operating Conditions.....	17
4.1.7 Test Results	18
4.2 Conducted Emission Measurement.....	21
4.2.1 Limits of Conducted Emission Measurement	21
4.2.2 Test Instruments	21
4.2.3 Test Procedures.....	22
4.2.4 Deviation from Test Standard	22
4.2.5 Test Setup.....	22
4.2.6 EUT Operating Condition	22
4.2.7 Test Results	23
5 Pictures of Test Arrangements.....	27
Annex A- Band Edge Measurement	28
Appendix – Information of the Testing Laboratories	29

Release Control Record

Issue No.	Description	Date Issued
RFCBVX-WTW-P22051015A	Original Release	Nov. 10, 2022

1 Certificate of Conformity

Product: CZ Smart, Sport (refer to item 3.1 for more details)

Brand: Citizen

Test Model: P991MV-01, P991MV-02 (refer to item 3.1 for more details)

Sample Status: Engineering Sample

Applicant: Citizen Watch CO., LTD.

Test Date: Oct. 08, 2022

Standards: 47 CFR FCC Part 15, Subpart C (Section 15.247)
ANSI C63.10:2013

The above equipment has been tested by **Bureau Veritas Consumer Products Services (H.K.) Ltd., Taoyuan Branch**, and found compliance with the requirement of the above standards. The test record, data evaluation & Equipment Under Test (EUT) configurations represented herein are true and accurate accounts of the measurements of the sample's RF characteristics under the conditions specified in this report.

Prepared by : *Vera Huang* , **Date:** Nov. 10, 2022
Vera Huang / Specialist

Approved by : *Jeremy Lin* , **Date:** Nov. 10, 2022
Jeremy Lin / Project Engineer

2 Summary of Test Results

47 CFR FCC Part 15, Subpart C (Section 15.247)			
FCC Clause	Test Item	Result	Remarks
15.207	AC Power Conducted Emission	Pass	Meet the requirement of limit. Minimum passing margin is -9.00 dB at 0.46568 MHz.
15.247(a)(1)(iii)	Number of Hopping Frequency Used	N/A	Refer to Note 1
15.247(a)(1)(iii)	Dwell Time on Each Channel	N/A	Refer to Note 1
15.247(a)(1)	1. Hopping Channel Separation 2. Spectrum Bandwidth of a Frequency Hopping Sequence Spread Spectrum System	N/A	Refer to Note 1
15.247(a) (1)	Maximum Peak Output Power	N/A	Refer to Note 1
---	Occupied Bandwidth Measurement	N/A	Refer to Note 1
15.205 & 209	Radiated Emissions	Pass	Meet the requirement of limit. Minimum passing margin is -4.3 dB at 2390.00 MHz.
15.247(d)	Band Edge Measurement	N/A	Refer to Note 1
15.247(d)	Antenna Port Emission	N/A	Refer to Note 1
15.203	Antenna Requirement	N/A	Refer to Note 1

Note:

1. Only worst mode of conducted emission and radiated emissions tests were performed for this addendum. Refer to original report for other test data.
2. For 2.4G band compliance with rule 15.247(d) of the band-edge items, the test plots were recorded in Annex A. Test Procedures refer to report 4.1.3.
3. Determining compliance based on the results of the compliance measurement, not taking into account measurement instrumentation uncertainty.

2.1 Measurement Uncertainty

Where relevant, the following measurement uncertainty levels have been estimated for tests performed on the EUT as specified in CISPR 16-4-2:

Measurement	Frequency	Expanded Uncertainty (k=2) (\pm)
Conducted Emissions at mains ports	150 kHz ~ 30 MHz	2.79 dB
Radiated Emissions up to 1 GHz	9 kHz ~ 30 MHz	3.04 dB
	30 MHz ~ 200 MHz	2.93 dB
	200 MHz ~ 1000 MHz	2.95 dB
Radiated Emissions above 1 GHz	1 GHz ~ 18 GHz	2.26 dB
	18 GHz ~ 40 GHz	1.94 dB

2.2 Modification Record

There were no modifications required for compliance.

3 General Information

3.1 General Description of EUT

Product	CZ Smart, Sport
Brand	Citizen
Test Model	P991MV-01, P991MV-02
Status of EUT	Engineering Sample
Power Supply Rating	5.0 Vdc (adapter or host equipment) 3.88 Vdc (Li-ion battery)
Modulation Type	GFSK, $\pi/4$ -DQPSK, 8DPSK
Transfer Rate	1/2/3 Mbps
Operating Frequency	2402 ~ 2480 MHz
Number of Channel	79
Antenna Type	Refer to Note as below
Antenna Connector	N/A
Accessory Device	Refer to Note as below
Data Cable Supplied	Refer to Note as below

Note:

1. This report is issued as a supplementary report to BV CPS report no.: RFCBVX-WTW-P22051015. The difference compared with the original report is adding one model (P991MV-02) with different appearance, antenna gain, and product name. Therefore, only worst mode of conducted emission and radiated emissions were verified and recorded in this report.
2. All models are listed as below. (New model is marked in boldface)

Product name	Model	Antenna type	Antenna gain (dBi)	Difference
CZ Smart	P991MV-01	PIFA	-5.72	All models are electrically identical, different antenna gain due to the enclosure, and difference model PMNs and model names are for marketing purpose.
Sport	P991MV-02	PIFA	-6.80	

3. The EUT contains following accessory devices.

Product	Brand	Model	Description
Charging Dock	Simula	CB407D-6040-202	Voltage Rating: 5V 0.95m shielded cable w/o core
Battery	Lishen	DAGP382427SA	3.88 Vdc, 300 mAh

4. Detail antenna specification please refer to antenna datasheet or an antenna gain measurement report.
5. The above EUT information is declared by manufacturer and for more detailed features description, please refers to the manufacturer's specifications or User's Manual.

3.2 Description of Test Modes

79 channels are provided to this EUT:

Channel	Freq. (MHz)	Channel	Freq. (MHz)	Channel	Freq. (MHz)	Channel	Freq. (MHz)
0	2402	20	2422	40	2442	60	2462
1	2403	21	2423	41	2443	61	2463
2	2404	22	2424	42	2444	62	2464
3	2405	23	2425	43	2445	63	2465
4	2406	24	2426	44	2446	64	2466
5	2407	25	2427	45	2447	65	2467
6	2408	26	2428	46	2448	66	2468
7	2409	27	2429	47	2449	67	2469
8	2410	28	2430	48	2450	68	2470
9	2411	29	2431	49	2451	69	2471
10	2412	30	2432	50	2452	70	2472
11	2413	31	2433	51	2453	71	2473
12	2414	32	2434	52	2454	72	2474
13	2415	33	2435	53	2455	73	2475
14	2416	34	2436	54	2456	74	2476
15	2417	35	2437	55	2457	75	2477
16	2418	36	2438	56	2458	76	2478
17	2419	37	2439	57	2459	77	2479
18	2420	38	2440	58	2460	78	2480
19	2421	39	2441	59	2461		

3.2.1 Test Mode Applicability and Tested Channel Detail

EUT Configure Mode	Applicable To				Description
	RE \geq 1G	RE $<$ 1G	PLC	APCM	
A	√	√	√	-	EUT + Adapter
B	-	-	√	-	EUT + Notebook

Where **RE \geq 1G**: Radiated Emission above 1 GHz **RE $<$ 1G**: Radiated Emission below 1 GHz
PLC: Power Line Conducted Emission **APCM**: Antenna Port Conducted Measurement

Note:

1. For Radiated emission test, pre-tested GFSK, $\pi/4$ -DQPSK, 8DPSK modulation type and found GFSK was the worse, therefore chosen for the final test and presented in the test report.
2. The EUT had been pre-tested on the positioned of each 3 axis. The worst case was found when positioned on **Z-plane**.
3. "-" means no effect.

Radiated Emission Test (Above 1 GHz):

- Pre-Scan has been conducted to determine the worst-case mode from all possible combinations between available modulations, data rates and antenna ports (if EUT with antenna diversity architecture).
- Following channel(s) was (were) selected for the final test as listed below.

EUT Configure Mode	Available Channel	Tested Channel	Modulation Technology	Modulation Type	Packet Type
A	0 to 78	0	FHSS	GFSK	DH5

Radiated Emission Test (Below 1 GHz):

- Pre-Scan has been conducted to determine the worst-case mode from all possible combinations between available modulations, data rates and antenna ports (if EUT with antenna diversity architecture).
- Following channel(s) was (were) selected for the final test as listed below.

EUT Configure Mode	Available Channel	Tested Channel	Modulation Technology	Modulation Type	Packet Type
A	0 to 78	0	FHSS	GFSK	DH5

Power Line Conducted Emission Test:

- Pre-Scan has been conducted to determine the worst-case mode from all possible combinations between available modulations, data rates and antenna ports (if EUT with antenna diversity architecture).
- Following channel(s) was (were) selected for the final test as listed below.

EUT Configure Mode	Available Channel	Tested Channel	Modulation Technology	Modulation Type	Packet Type
A, B	0 to 78	0	FHSS	GFSK	DH5

Test Condition:

Applicable To	Environmental Conditions	Input Power	Tested by
RE \geq 1G	21.3 deg. C, 70.3 % RH	120 Vac, 60 Hz	Vincent Chen
RE $<$ 1G	25 deg. C, 75 % RH	120 Vac, 60 Hz	Vincent Chen
PLC	23 deg. C, 65 % RH	120 Vac, 60 Hz	Vincent Chen

3.3 Duty Cycle of Test Signal

Duty cycle = $3/100 = 0.03$, Duty factor = $20 * \log(0.03) = -30.5$

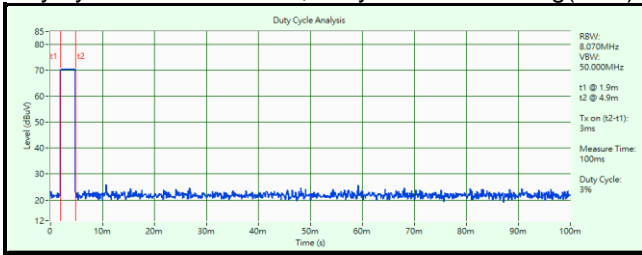

3.4 Description of Support Units

The EUT has been tested as an independent unit together with other necessary accessories or support units. The following support units or accessories were used to form a representative test configuration during the tests.

ID	Product	Brand	Model No.	Serial No.	FCC ID	Remarks
A	Adapter	Liteon	PA-1050-39	NA	NA	Provided by Lab
B	Notebook	DELL	Inspiron 14R	8LRKKW1	NA	Provided by Lab
C	Bluetooth Tester	R&S	CBT	100946	NA	Provided by Lab

Note:

1. All power cords of the above support units are non-shielded (1.8m).
2. Item C acted as a communication partner to transfer data.

ID	Descriptions	Qty.	Length (m)	Shielding (Yes/No)	Cores (Qty.)	Remarks
1.	Charging Cable	1	0.95	Y	0	Accessory of the EUT

3.4.1 Configuration of System under Test

Mode A

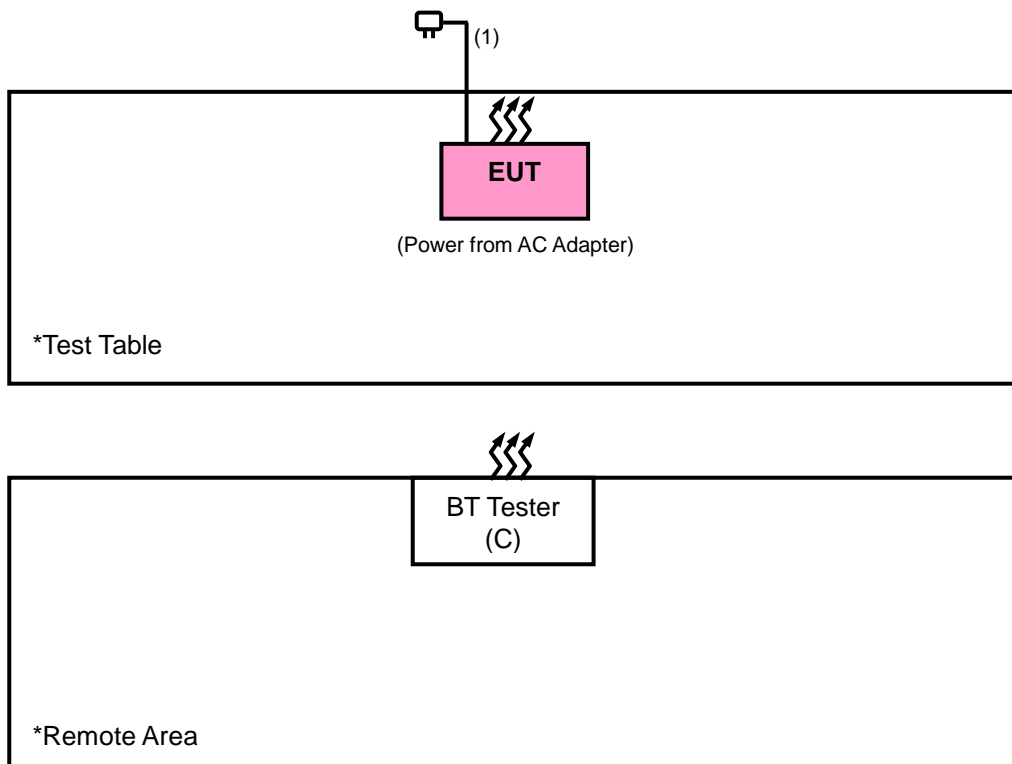

Mode B

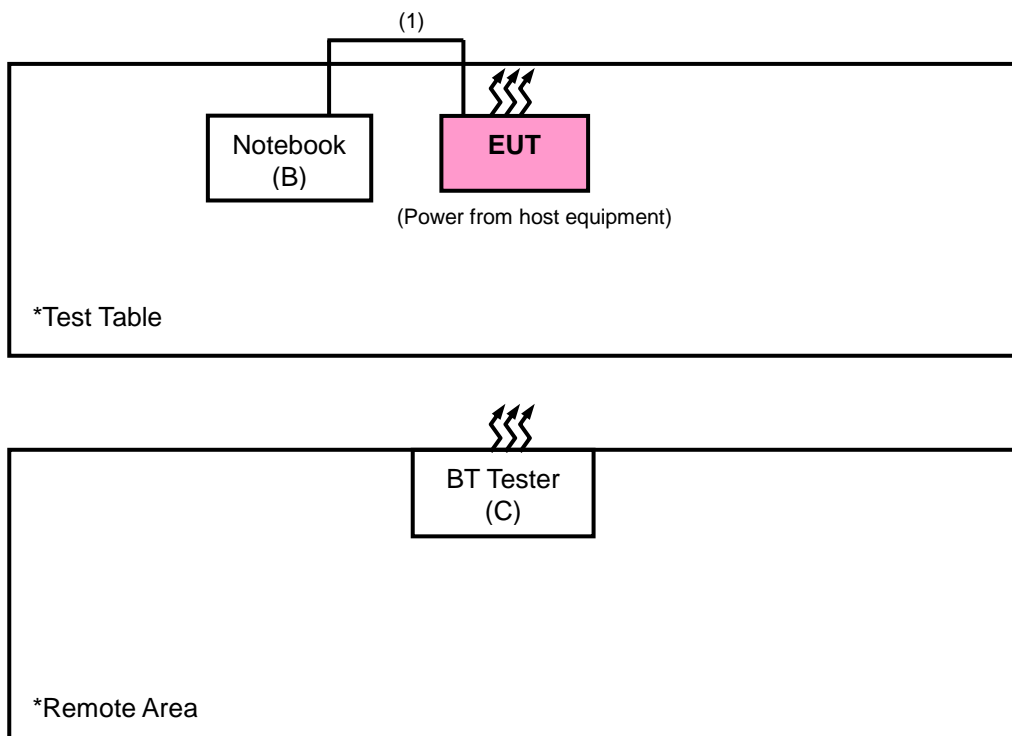

3.5 General Description of Applied Standards and References

The EUT is a RF Product. According to the specifications of the manufacturer, it must comply with the requirements of the following standards and references:

Test Standard:

FCC Part 15, Subpart C (15.247)

ANSI C63.10-2013

All test items have been performed and recorded as per the above standards.

References Test Guidance:

KDB 558074 D01 15.247 Meas Guidance v05r02

All test items have been performed as a reference to the above KDB test guidance.

4 Test Types and Results

4.1 Radiated Emission and Bandedge Measurement

4.1.1 Limits of Radiated Emission and Bandedge Measurement

Radiated emissions which fall in the restricted bands must comply with the radiated emission limits specified as below table. Other emissions shall be at least 20 dB below the highest level of the desired power:

Frequencies (MHz)	Field Strength (microvolts/meter)	Measurement Distance (meters)
0.009 ~ 0.490	2400/F (kHz)	300
0.490 ~ 1.705	24000/F (kHz)	30
1.705 ~ 30.0	30	30
30 ~ 88	100	3
88 ~ 216	150	3
216 ~ 960	200	3
Above 960	500	3

Note:

- a. The lower limit shall apply at the transition frequencies.
- b. Emission level (dBuV/m) = 20 log Emission level (uV/m).
- c. For frequencies above 1000 MHz, the field strength limits are based on average detector, however, the peak field strength of any emission shall not exceed the maximum permitted average limits, specified above by more than 20 dB under any condition of modulation.

4.1.2 Test Instruments

Description & Manufacturer	Model No.	Serial No.	Date of Calibration	Due Date of Calibration
Spectrum Analyzer Agilent	N9038A	MY51210129	Apr. 08, 2022	Apr. 07, 2023
Spectrum Analyzer Agilent	N9010A	MY52220314	Dec. 03, 2021	Dec. 02, 2022
HORN Antenna SCHWARZBECK	BBHA 9170	9170-480	Nov. 14, 2021	Nov. 13, 2022
HORN Antenna SCHWARZBECK	BBHA 9120D	9120D-969	Nov. 14, 2021	Nov. 13, 2022
BILOG Antenna SCHWARZBECK	VULB 9168	9168-472	Oct. 28, 2021	Oct. 27, 2022
Fixed Attenuator WOKEN	MDCS18N-10	MDCS18N-10-01	Apr. 05, 2022	Apr. 04, 2023
Loop Antenna	EM-6879	269	Sep. 19, 2022	Sep. 18, 2023
Preamplifier EMCI	EMC001340	980201	Sep. 23, 2022	Sep. 22, 2023
Preamplifier EMCI	EMC 012645	980115	Oct. 01, 2022	Sep. 30, 2023
Preamplifier EMCI	EMC 330H	980112	Oct. 01, 2022	Sep. 30, 2023
RF Coaxial Cable EMCI	EMC104-SM-SM-8000	171005	Oct. 01, 2022	Sep. 30, 2023
RF Coaxial Cable HUBER+SUHNNER	SUCOFLEX 104	EMC104-SM-SM-1000(140807)	Oct. 01, 2022	Sep. 30, 2023
RF Coaxial Cable WOKEN	8D-FB	Cable-Ch10-01	Oct. 01, 2022	Sep. 30, 2023
Boresight Antenna Fixture	FBA-01	FBA-SIP01	NA	NA
Software BV ADT	E3 6.120103	NA	NA	NA
Antenna Tower MF	MFA-440H	NA	NA	NA
Turn Table MF	MFT-201SS	NA	NA	NA
Antenna Tower & Turn Table Controller MF	MF-7802	NA	NA	NA
Bluetooth Tester	CBT	100946	Aug. 05, 2022	Aug. 04, 2024

- Note: 1. The calibration interval of the above test instruments is 12/24 months and the calibrations are traceable to NML/ROC and NIST/USA.
 2. The test was performed in HwaYa Chamber 10.

4.1.3 Test Procedures

For Radiated Emission below 30 MHz

- a. The EUT was placed on the top of a rotating table 0.8 meters above the ground at a 3 meter chamber room. The table was rotated 360 degrees to determine the position of the highest radiation.
- b. The EUT was set 3 meters away from the interference-receiving antenna, which was mounted on the top of a variable-height antenna tower.
- c. Parallel, perpendicular, and ground-parallel orientations of the antenna are set to make the measurement.
- d. For each suspected emission, the EUT was arranged to its worst case and the rotatable table was turned from 0 degrees to 360 degrees to find the maximum reading.
- e. The test-receiver system was set to Quasi-Peak Detect Function and Specified Bandwidth with Maximum Hold Mode.

Note:

1. The resolution bandwidth and video bandwidth of test receiver/spectrum analyzer is 9 kHz at frequency below 30 MHz.

For Radiated Emission above 30 MHz

- a. The EUT was placed on the top of a rotating table 0.8 meters (for 30 MHz ~ 1 GHz) / 1.5 meters (for above 1 GHz) above the ground at 3 meter chamber room for test. The table was rotated 360 degrees to determine the position of the highest radiation.
- b. The EUT was set 3 meters away from the interference-receiving antenna, which was mounted on the top of a variable-height antenna tower.
- c. The height of antenna is varied from one meter to four meters above the ground to determine the maximum value of the field strength. Both horizontal and vertical polarizations of the antenna are set to make the measurement.
- d. For each suspected emission, the EUT was arranged to its worst case and then the antenna was tuned to heights from 1 meter to 4 meters and the rotatable table was turned from 0 degrees to 360 degrees to find the maximum reading.
- e. The test-receiver system was set to quasi-peak detect function and specified bandwidth with maximum hold mode when the test frequency is below 1 GHz.
- f. The test-receiver system was set to peak and average detected function and specified bandwidth with maximum hold mode when the test frequency is above 1 GHz. If the peak reading value also meets average limit, measurement with the average detector is unnecessary.

Note:

1. The resolution bandwidth and video bandwidth of test receiver/spectrum analyzer is 120 kHz for Quasi-peak detection (QP) at frequency below 1 GHz.
2. The resolution bandwidth of test receiver/spectrum analyzer is 1 MHz and the video bandwidth is 3 MHz for Peak detection (PK) and Average detection (AV) at frequency above 1 GHz.
3. For Fundamental frequency and band edge & harmonic:
The average value of fundamental frequency is : average value = peak value + $20 \cdot \log(\text{Duty cycle})$ where the duty cycle correction factor is calculated from following formula:
 $20 \cdot \log(\text{Duty cycle}) = 20 \cdot \log(3 \text{ ms}/100) = -30.5 \text{ dB}$, please refer to the plotted duty (see section 3.3)
4. All modes of operation were investigated and the worst-case emissions are reported.

4.1.4 Deviation from Test Standard

No deviation.

4.1.5 Test Set Up

<Radiated Emission below 30 MHz>

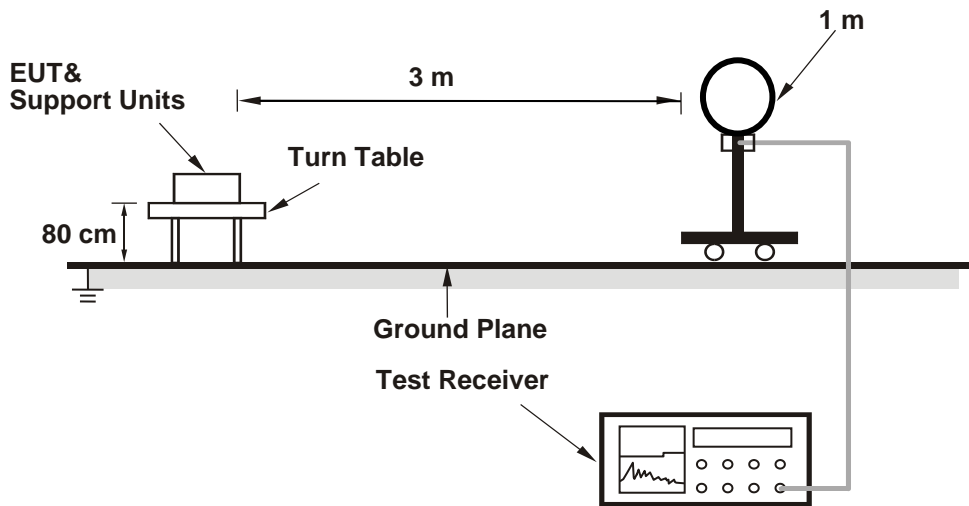

<Radiated Emission 30 MHz to 1 GHz>

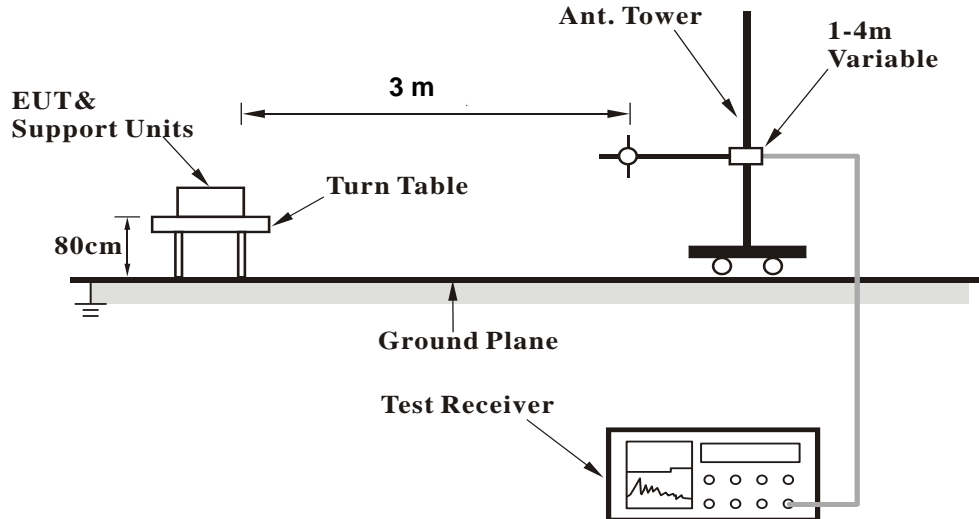

<Radiated Emission above 1 GHz>

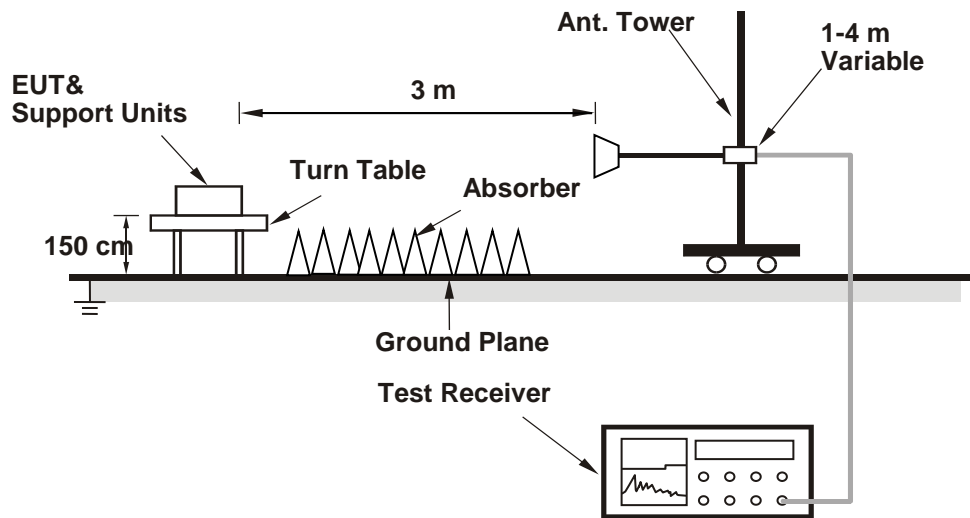

For the actual test configuration, please refer to the attached file (Test Setup Photo).

4.1.6 EUT Operating Conditions

Set the EUT under transmission condition continuously at specific channel frequency.

4.1.7 Test Results

Above 1 GHz Data:

RF Mode	TX BT_GFSK	Channel	CH 0 : 2402 MHz
Frequency Range	1GHz ~ 25GHz	Detector Function	Peak (PK) Average (AV)

Antenna Polarity & Test Distance : Horizontal at 3 m								
No	Frequency (MHz)	Emission Level (dBuV/m)	Limit (dBuV/m)	Margin (dB)	Antenna Height (m)	Table Angle (Degree)	Raw Value (dBuV)	Correction Factor (dB/m)
1	2390.00	58.5 PK	74.0	-15.5	1.31 H	6	26.4	32.1
2	2390.00	49.7 AV	54.0	-4.3	1.31 H	6	17.6	32.1
3	*2402.00	103.2 PK			1.31 H	6	71.2	32.0
4	*2402.00	72.7 AV			1.31 H	6	40.7	32.0
5	4804.00	45.4 PK	74.0	-28.6	3.23 H	257	53.4	-8.0
6	4804.00	14.9 AV	54.0	-39.1	3.23 H	257	22.9	-8.0
Antenna Polarity & Test Distance : Vertical at 3 m								
No	Frequency (MHz)	Emission Level (dBuV/m)	Limit (dBuV/m)	Margin (dB)	Antenna Height (m)	Table Angle (Degree)	Raw Value (dBuV)	Correction Factor (dB/m)
1	2390.00	58.1 PK	74.0	-15.9	3.24 V	92	26.0	32.1
2	2390.00	49.6 AV	54.0	-4.4	3.24 V	92	17.5	32.1
3	*2402.00	97.8 PK			3.24 V	92	65.8	32.0
4	*2402.00	67.3 AV			3.24 V	92	35.3	32.0
5	4804.00	44.1 PK	74.0	-29.9	3.65 V	287	52.1	-8.0
6	4804.00	13.6 AV	54.0	-40.4	3.65 V	287	21.6	-8.0

Remarks:

1. Emission Level(dBuV/m) = Raw Value(dBuV) + Correction Factor(dB/m)
2. Correction Factor(dB/m) = Antenna Factor(dB/m) + Cable Factor(dB) – Pre-Amplifier Factor(dB)
3. Margin value = Emission Level – Limit value
4. The other emission levels were very low against the limit.
5. " * ": Fundamental frequency.

Below 1 GHz Worst-Case Data:

RF Mode	TX BT_GFSK	Channel	CH 0 : 2402 MHz
Frequency Range	9kHz ~ 1GHz	Detector Function	Quasi-Peak (QP)

Antenna Polarity & Test Distance : Horizontal at 3 m								
No	Frequency (MHz)	Emission Level (dBuV/m)	Limit (dBuV/m)	Margin (dB)	Antenna Height (m)	Table Angle (Degree)	Raw Value (dBuV)	Correction Factor (dB/m)
1	54.25	26.0 QP	40.0	-14.0	1.50 H	219	38.9	-12.9
2	140.58	28.1 QP	43.5	-15.4	1.00 H	233	40.7	-12.6
3	430.61	23.6 QP	46.0	-22.4	2.00 H	196	31.6	-8.0
4	600.36	27.0 QP	46.0	-19.0	1.00 H	7	30.5	-3.5
5	863.23	30.6 QP	46.0	-15.4	2.00 H	159	29.4	1.2
6	955.38	30.3 QP	46.0	-15.7	2.00 H	102	27.6	2.7

Remarks:

1. Emission Level(dBuV/m) = Raw Value(dBuV) + Correction Factor(dB/m)
2. Correction Factor(dB/m) = Antenna Factor(dB/m) + Cable Factor(dB) – Pre-Amplifier Factor(dB)
3. Margin value = Emission Level – Limit value
4. The other emission levels were very low against the limit of frequency range 30 MHz ~ 1 GHz.
5. The emission levels were very low against the limit of frequency range 9 kHz ~ 30 MHz: the amplitude of spurious emissions attenuated more than 20 dB below the permissible value to be report.

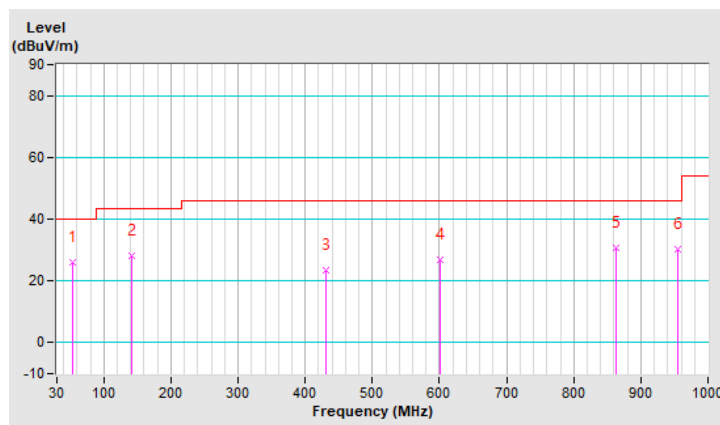

RF Mode	TX BT_GFSK	Channel	CH 0 : 2402 MHz
Frequency Range	9kHz ~ 1GHz	Detector Function	Quasi-Peak (QP)

Antenna Polarity & Test Distance : Vertical at 3 m								
No	Frequency (MHz)	Emission Level (dBuV/m)	Limit (dBuV/m)	Margin (dB)	Antenna Height (m)	Table Angle (Degree)	Raw Value (dBuV)	Correction Factor (dB/m)
1	38.73	24.9 QP	40.0	-15.1	1.50 V	17	38.3	-13.4
2	118.27	27.9 QP	43.5	-15.6	1.00 V	190	42.4	-14.5
3	144.46	27.7 QP	43.5	-15.8	1.50 V	360	40.0	-12.3
4	441.28	24.3 QP	46.0	-21.7	1.00 V	78	31.8	-7.5
5	626.55	27.5 QP	46.0	-18.5	2.00 V	114	30.3	-2.8
6	885.54	29.9 QP	46.0	-16.1	2.00 V	288	28.4	1.5

Remarks:

1. Emission Level(dBuV/m) = Raw Value(dBuV) + Correction Factor(dB/m)
2. Correction Factor(dB/m) = Antenna Factor(dB/m) + Cable Factor(dB) – Pre-Amplifier Factor(dB)
3. Margin value = Emission Level – Limit value
4. The other emission levels were very low against the limit of frequency range 30 MHz ~ 1 GHz.
5. The emission levels were very low against the limit of frequency range 9 kHz ~ 30 MHz: the amplitude of spurious emissions attenuated more than 20 dB below the permissible value to be report.

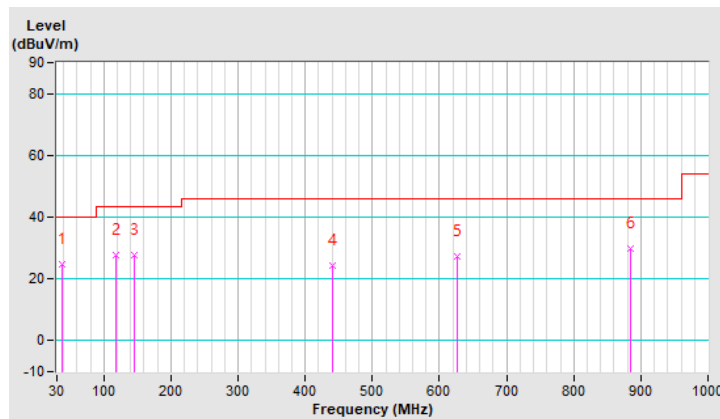

4.2 Conducted Emission Measurement

4.2.1 Limits of Conducted Emission Measurement

Frequency (MHz)	Conducted Limit (dBuV)	
	Quasi-Peak	Average
0.15 - 0.5	66 - 56	56 - 46
0.50 - 5.0	56	46
5.0 - 30.0	60	50

- Note: 1. The lower limit shall apply at the transition frequencies.
 2. The limit decreases in line with the logarithm of the frequency in the range of 0.15 to 0.50 MHz.

4.2.2 Test Instruments

Description & Manufacturer	Model No.	Serial No.	Date of Calibration	Due Date of Calibration
Test Receiver ROHDE & SCHWARZ	ESCI	100613	Dec. 03, 2021	Dec. 02, 2022
RF signal cable Woken	5D-FB	Cable-cond1-01	Jan. 15, 2022	Jan. 14, 2023
LISN/AMN ROHDE & SCHWARZ (EUT)	ENV216	101826	Mar. 14, 2022	Mar. 13, 2023
LISN/AMN ROHDE & SCHWARZ (Peripheral)	ESH3-Z5	100311	Sep. 12, 2022	Sep. 11, 2023
Software ADT	BV ADT_Cond_ V7.3.7.4	NA	NA	NA

- Note: 1. The calibration interval of the above test instruments is 12 months and the calibrations are traceable to NML/ROC and NIST/USA.
 2. The test was performed in HwaYa Shielded Room 1 (Conduction 1).
 3. The VCCI Site Registration No. is C-12040.

4.2.3 Test Procedures

- The EUT was placed 0.4 meters from the conducting wall of the shielded room with EUT being connected to the power mains through a line impedance stabilization network (LISN). Other support units were connected to the power mains through another LISN. The two LISNs provide 50 ohm/ 50 uH of coupling impedance for the measuring instrument.
- Both lines of the power mains connected to the EUT were checked for maximum conducted interference.
- The frequency range from 150 kHz to 30 MHz was searched. Emission levels under (Limit – 20 dB) was not recorded.

Note: The resolution bandwidth and video bandwidth of test receiver is 9 kHz for quasi-peak detection (QP) and average detection (AV) at frequency 0.15 MHz - 30 MHz.

4.2.4 Deviation from Test Standard

No deviation.

4.2.5 Test Setup

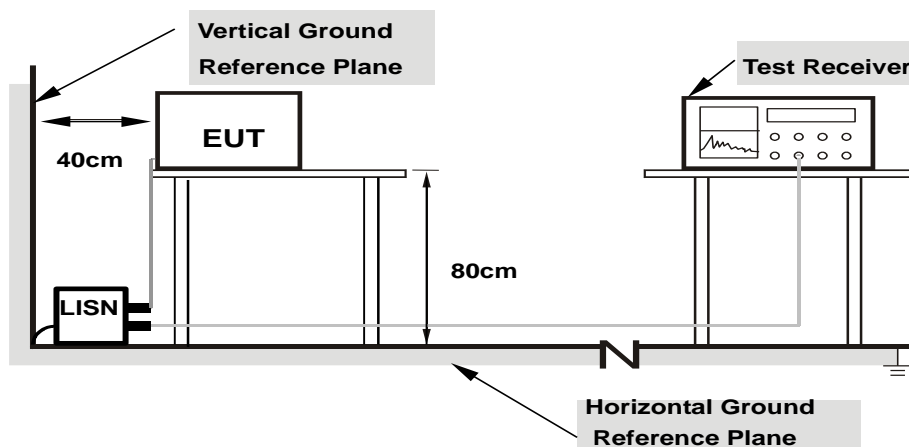

- Note:**
- Support units were connected to second LISN.
 - Both of LISNs (AMN) are 80 cm from EUT and at least 80 from other units and other metal planes

For the actual test configuration, please refer to the attached file (Test Setup Photo).

4.2.6 EUT Operating Condition

Set the EUT under transmission condition continuously at specific channel frequency.

4.2.7 Test Results

Mode A

Frequency Range	150kHz ~ 30MHz	Detector Function & Resolution Bandwidth	Quasi-Peak (QP) / Average (AV), 9kHz
Input Power	120Vac, 60Hz	Environmental Conditions	23 °C, 65% RH
Tested by	Vincent Chen		

Phase Of Power : Line (L)										
No	Frequency (MHz)	Correction Factor (dB)	Reading Value (dBuV)		Emission Level (dBuV)		Limit (dBuV)		Margin (dB)	
			Q.P.	AV.	Q.P.	AV.	Q.P.	AV.	Q.P.	AV.
1	0.18200	9.71	23.10	11.27	32.81	20.98	64.39	54.39	-31.58	-33.41
2	0.22985	9.73	20.07	8.73	29.80	18.46	62.46	52.46	-32.66	-34.00
3	0.46200	9.80	27.56	24.07	37.36	33.87	56.66	46.66	-19.30	-12.79
4	0.67400	9.82	14.44	9.84	24.26	19.66	56.00	46.00	-31.74	-26.34
5	5.29800	9.97	12.11	4.74	22.08	14.71	60.00	50.00	-37.92	-35.29
6	21.13000	10.16	13.40	3.92	23.56	14.08	60.00	50.00	-36.44	-35.92

Remarks:

1. Q.P. and AV. are abbreviations of quasi-peak and average individually.
2. The emission levels of other frequencies were very low against the limit.
3. Margin value = Emission level – Limit value
4. Correction factor = Insertion loss + Cable loss
5. Emission Level = Correction Factor + Reading Value

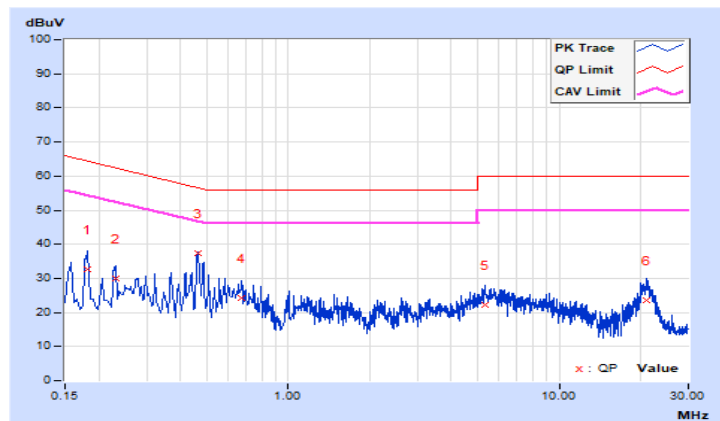

Frequency Range	150kHz ~ 30MHz	Detector Function & Resolution Bandwidth	Quasi-Peak (QP) / Average (AV), 9kHz
Input Power	120Vac, 60Hz	Environmental Conditions	23 °C, 65% RH
Tested by	Vincent Chen		

Phase Of Power : Neutral (N)										
No	Frequency (MHz)	Correction Factor (dB)	Reading Value (dBuV)		Emission Level (dBuV)		Limit (dBuV)		Margin (dB)	
			Q.P.	AV.	Q.P.	AV.	Q.P.	AV.	Q.P.	AV.
1	0.19000	9.71	20.89	13.66	30.60	23.37	64.04	54.04	-33.44	-30.67
2	0.46568	9.82	31.48	27.77	41.30	37.59	56.59	46.59	-15.29	-9.00
3	1.22600	9.87	16.67	9.84	26.54	19.71	56.00	46.00	-29.46	-26.29
4	2.69000	9.94	12.73	7.53	22.67	17.47	56.00	46.00	-33.33	-28.53
5	17.23800	10.16	7.81	0.48	17.97	10.64	60.00	50.00	-42.03	-39.36
6	21.24600	10.20	11.45	3.38	21.65	13.58	60.00	50.00	-38.35	-36.42

Remarks:

1. Q.P. and AV. are abbreviations of quasi-peak and average individually.
2. The emission levels of other frequencies were very low against the limit.
3. Margin value = Emission level – Limit value
4. Correction factor = Insertion loss + Cable loss
5. Emission Level = Correction Factor + Reading Value

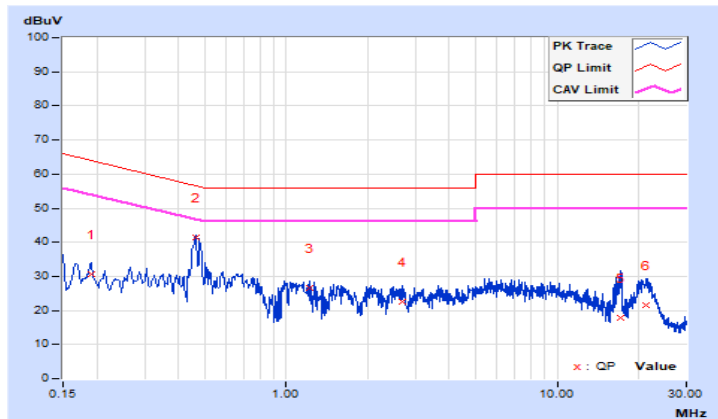

Mode B

Frequency Range	150kHz ~ 30MHz	Detector Function & Resolution Bandwidth	Quasi-Peak (QP) / Average (AV), 9kHz
Input Power	120Vac, 60Hz	Environmental Conditions	23 °C, 65% RH
Tested by	Vincent Chen		

Phase Of Power : Line (L)										
No	Frequency (MHz)	Correction Factor (dB)	Reading Value (dBuV)		Emission Level (dBuV)		Limit (dBuV)		Margin (dB)	
			Q.P.	AV.	Q.P.	AV.	Q.P.	AV.	Q.P.	AV.
1	0.15400	9.62	36.71	18.87	46.33	28.49	65.78	55.78	-19.45	-27.29
2	0.17800	9.63	36.66	20.59	46.29	30.22	64.58	54.58	-18.29	-24.36
3	0.35000	9.68	15.44	4.36	25.12	14.04	58.96	48.96	-33.84	-34.92
4	3.41000	9.74	24.11	16.59	33.85	26.33	56.00	46.00	-22.15	-19.67
5	4.78200	9.76	20.63	15.47	30.39	25.23	56.00	46.00	-25.61	-20.77
6	22.01800	9.87	21.81	11.90	31.68	21.77	60.00	50.00	-28.32	-28.23

Remarks:

1. Q.P. and AV. are abbreviations of quasi-peak and average individually.
2. The emission levels of other frequencies were very low against the limit.
3. Margin value = Emission level – Limit value
4. Correction factor = Insertion loss + Cable loss
5. Emission Level = Correction Factor + Reading Value

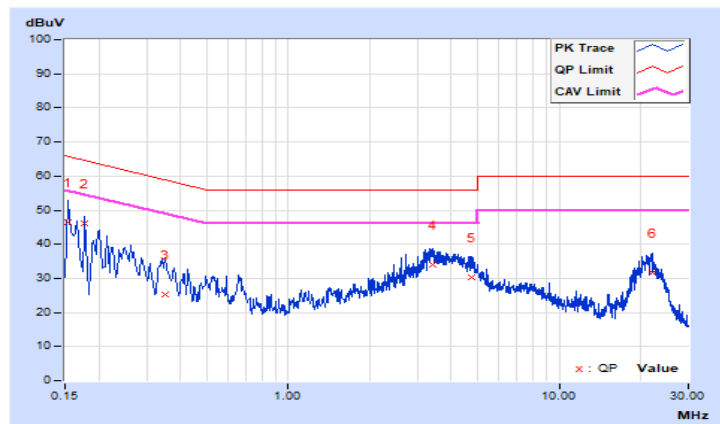

Frequency Range	150kHz ~ 30MHz	Detector Function & Resolution Bandwidth	Quasi-Peak (QP) / Average (AV), 9kHz
Input Power	120Vac, 60Hz	Environmental Conditions	23 °C, 65% RH
Tested by	Vincent Chen		

Phase Of Power : Neutral (N)										
No	Frequency (MHz)	Correction Factor (dB)	Reading Value (dBuV)		Emission Level (dBuV)		Limit (dBuV)		Margin (dB)	
			Q.P.	AV.	Q.P.	AV.	Q.P.	AV.	Q.P.	AV.
1	0.17400	9.63	36.08	19.80	45.71	29.43	64.77	54.77	-19.06	-25.34
2	0.21000	9.64	32.19	14.39	41.83	24.03	63.21	53.21	-21.38	-29.18
3	0.51744	9.69	18.86	10.84	28.55	20.53	56.00	46.00	-27.45	-25.47
4	3.57000	9.75	25.00	18.10	34.75	27.85	56.00	46.00	-21.25	-18.15
5	7.47800	9.78	16.51	11.31	26.29	21.09	60.00	50.00	-33.71	-28.91
6	21.81800	9.89	20.97	11.20	30.86	21.09	60.00	50.00	-29.14	-28.91

Remarks:

1. Q.P. and AV. are abbreviations of quasi-peak and average individually.
2. The emission levels of other frequencies were very low against the limit.
3. Margin value = Emission level – Limit value
4. Correction factor = Insertion loss + Cable loss
5. Emission Level = Correction Factor + Reading Value

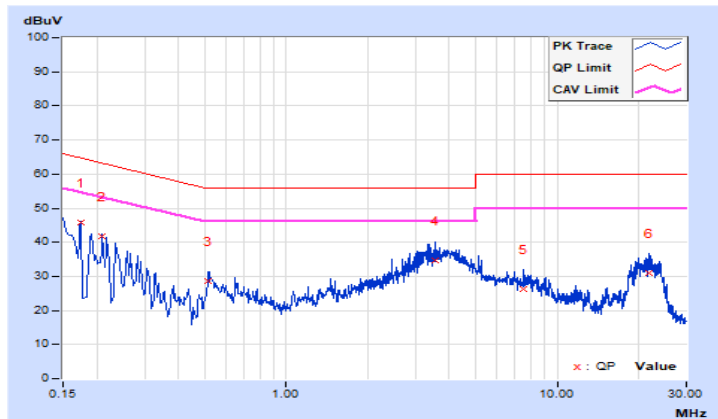

5 Pictures of Test Arrangements

Please refer to the attached file (Test Setup Photo).

Annex A- Band Edge Measurement

BT GFSK Channel 0

Horizontal (Peak)

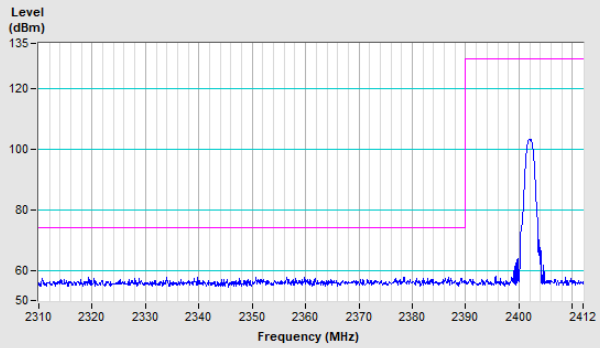

Vertical (Peak)

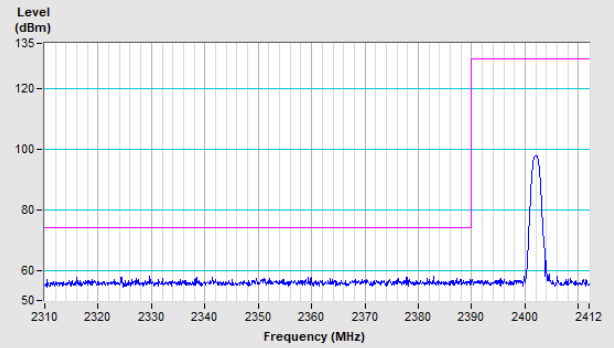

Appendix – Information of the Testing Laboratories

We, Bureau Veritas Consumer Products Services (H.K.) Ltd., Taoyuan Branch, were founded in 1988 to provide our best service in EMC, Radio, Telecom and Safety consultation. Our laboratories are FCC recognized accredited test firms and accredited according to ISO/IEC 17025.

If you have any comments, please feel free to contact us at the following:

Lin Kou EMC/RF Lab

Tel: 886-2-26052180

Fax: 886-2-26051924

Hsin Chu EMC/RF/Telecom Lab

Tel: 886-3-6668565

Fax: 886-3-6668323

Hwa Ya EMC/RF/Safety Lab

Tel: 886-3-3183232

Fax: 886-3-3270892

Email: service.adt@tw.bureauveritas.com

Web Site: www.bureauveritas-adt.com

The address and road map of all our labs can be found in our web site also.

--- END ---