



SPORTON International Inc.

No. 52, Hwa Ya 1st Rd., Kwei-Shan Hsiang, TaoYuan Hsien, Taiwan, R.O.C.
Ph: 886-3-327-3456 / FAX: 886-3-327-0973 / www.sporton.com.tw

FCC RADIO TEST REPORT

Applicant's company	Teldat S.A.
Applicant Address	Isaac Newton, 10, Parque Tecnológico de Madrid, 28760 – Tres Cantos, Madrid, Spain
FCC ID	YUAWMCND03TD
Manufacturer's company	Alpha Networks Inc.
Manufacturer Address	No.8 Li-shing 7th Rd., Science-based Industrial Park, Hsinchu, Taiwan, R.O.C.
Manufacturer's company	Alpha Networks (Dongguan) Co., Ltd.
Manufacturer Address	Xin An District, Chang An Town, DongGuan City, GuangDong Province, China

Product Name	WiFi module
Brand Name	Teldat
Model Name	WMCND03TD
Test Rule Part(s)	47 CFR FCC Part 15 Subpart E § 15.407
Test Freq. Range	5150 ~ 5350MHz / 5470 ~ 5725MHz
Received Date	Jan. 24, 2013
Final Test Date	Feb. 26, 2013
Submission Type	Original Equipment
Operating Mode	Client (without radar detection function)



Statement

Test result included is for the IEEE 802.11n and IEEE 802.11a (5150 ~ 5350MHz / 5470 ~ 5725MHz) of the product.

The test result in this report refers exclusively to the presented test model / sample.

Without written approval of SPORTON International Inc., the test report shall not be reproduced except in full.

The measurements and test results shown in this test report were made in accordance with the procedures and found in compliance with the limit given in **ANSI C63.10-2009**,

47 CFR FCC Part 15 Subpart E, KDB 789033 D01 v01r02 and KDB 662911 D01 v01r02.

The test equipment used to perform the test is calibrated and traceable to NML/ROC.





Table of Contents

1. CERTIFICATE OF COMPLIANCE	1
2. SUMMARY OF THE TEST RESULT	2
3. GENERAL INFORMATION	3
3.1. Product Details	3
3.2. Accessories	5
3.3. Table for Filed Antenna	5
3.4. Table for Carrier Frequencies	6
3.5. Table for Test Modes	7
3.6. Table for Testing Locations.....	8
3.7. Table for Supporting Units	9
3.8. Table for Parameters of Test Software Setting	10
3.9. Test Configurations.....	11
4. TEST RESULT	14
4.1. AC Power Line Conducted Emissions Measurement	14
4.2. 99% Occupied Bandwidth Measurement.....	18
4.3. Maximum Conducted Output Power Measurement.....	34
4.4. Power Spectral Density Measurement.....	38
4.5. Peak Excursion Measurement	47
4.6. Radiated Emissions Measurement.....	55
4.7. Band Edge Emissions Measurement.....	86
4.8. Frequency Stability Measurement.....	97
4.9. Antenna Requirements	99
5. LIST OF MEASURING EQUIPMENTS	100
6. TEST LOCATION	102
APPENDIX A. TEST PHOTOS	A1 ~ A8
APPENDIX B. MAXIMUM PERMISSIBLE EXPOSURE	B1 ~ B3



History of This Test Report

REPORT NO.	VERSION	DESCRIPTION	ISSUED DATE
FR311203-01AB	Rev. 01	Initial issue of report	Mar. 28, 2013
FR311203-01AB	Rev. 02	Revised Applicant Address	Apr. 09, 2013



1. CERTIFICATE OF COMPLIANCE

Product Name : WiFi module
Brand Name : Teldat
Model Name : WMCND03TD
Applicant : Teldat S.A.
Test Rule Part(s) : 47 CFR FCC Part 15 Subpart E § 15.407

Sporton International as requested by the applicant to evaluate the EMC performance of the product sample received on Jan. 24, 2013 would like to declare that the tested sample has been evaluated and found to be in compliance with the tested rule parts. The data recorded as well as the test configuration specified is true and accurate for showing the sample's EMC nature.

A handwritten signature in blue ink that reads 'Sam Chen' is written over a horizontal line.

Sam Chen

SPORTON INTERNATIONAL INC.

2. SUMMARY OF THE TEST RESULT

Applied Standard: 47 CFR FCC Part 15 Subpart E				
Part	Rule Section	Description of Test	Result	Under Limit
4.1	15.207	AC Power Line Conducted Emissions	Complies	10.74 dB
4.2	15.407(a)	26dB Spectrum Bandwidth	Complies	-
4.3	15.407(a)	Maximum Conducted Output Power	Complies	0.08 dB
4.4	15.407(a)	Power Spectral Density	Complies	0.40 dB
4.5	15.407(a)	Peak Excursion	Complies	2.19 dB
4.6	15.407(b)	Radiated Emissions	Complies	1.34 dB
4.7	15.407(b)	Band Edge Emissions	Complies	0.07 dB
4.8	15.407(g)	Frequency Stability	Complies	-
4.9	15.203	Antenna Requirements	Complies	-

Test Items	Uncertainty	Remark
AC Power Line Conducted Emissions	±2.3dB	Confidence levels of 95%
Maximum Conducted Output Power	±0.5dB	Confidence levels of 95%
Power Spectral Density	±0.5dB	Confidence levels of 95%
Peak Excursion	±0.5dB	Confidence levels of 95%
26dB Spectrum Bandwidth / Frequency Stability	±8.5×10 ⁻⁸	Confidence levels of 95%
Radiated Emissions (9kHz~30MHz)	±0.8dB	Confidence levels of 95%
Radiated Emissions (30MHz~1000MHz)	±1.9dB	Confidence levels of 95%
Radiated / Band Edge Emissions (1GHz~18GHz)	±1.9dB	Confidence levels of 95%
Radiated Emissions (18GHz~40GHz)	±1.9dB	Confidence levels of 95%
Temperature	±0.7°C	Confidence levels of 95%
Humidity	±3.2%	Confidence levels of 95%
DC / AC Power Source	±1.4%	Confidence levels of 95%

3. GENERAL INFORMATION

3.1. Product Details

IEEE 802.11n

Items	Description
Product Type	WLAN (2TX, 2RX)
Radio Type	Intentional Transceiver
Power Type	From Host System
Modulation	see the below table for IEEE 802.11n
Data Modulation	OFDM (BPSK / QPSK / 16QAM / 64QAM)
Data Rate (Mbps)	see the below table for IEEE 802.11n
Frequency Range	5150 ~ 5350MHz / 5470 ~ 5725MHz
Channel Number	16 for 20MHz bandwidth ; 7 for 40MHz bandwidth
Channel Band Width (99%)	MCS0 (20MHz): 24.64 MHz ; MCS0 (40MHz): 52.16 MHz
Maximum Conducted Output Power	Band 1: MCS0 (20MHz): 16.87 dBm ; MCS0 (40MHz): 16.41 dBm Band 2: MCS0 (20MHz): 23.92 dBm ; MCS0 (40MHz): 23.66 dBm Band 3: MCS0 (20MHz): 23.75 dBm ; MCS0 (40MHz): 23.85 dBm
Carrier Frequencies	Please refer to section 3.4
Antenna	Please refer to section 3.3

IEEE 802.11a

Items	Description
Product Type	WLAN (2TX, 2RX)
Radio Type	Intentional Transceiver
Power Type	From Host System
Modulation	OFDM for IEEE 802.11a
Data Modulation	OFDM (BPSK / QPSK / 16QAM / 64QAM)
Data Rate (Mbps)	OFDM (6/9/12/18/24/36/48/54/108)
Frequency Range	5150 ~ 5350MHz / 5470 ~ 5725MHz
Channel Number	16
Channel Band Width (99%)	11a: 25.44 MHz
Maximum Conducted Output Power	Band 1: 16.78 dBm ; Band 2: 23.73 dBm ; Band 3: 23.73 dBm
Carrier Frequencies	Please refer to section 3.4
Antenna	Please refer to section 3.3

Antenna & Band width

Antenna	Single (TX)		Two (TX)	
	20 MHz	40 MHz	20 MHz	40 MHz
IEEE 802.11a	X	X	V	X
IEEE 802.11n	X	X	V	V

IEEE 802.11n spec

MCS Index	Nss	Modulation	R	NBPS	NCBPS		NDBPS		Datarate(Mbps)			
					20MHz	40MHz	20MHz	40MHz	800nsGI		400nsGI	
									20MHz	40MHz	20MHz	40MHz
0	1	BPSK	1/2	1	52	108	26	54	6.5	13.5	7.200	15
1	1	QPSK	1/2	2	104	216	52	108	13.0	27.0	14.400	30
2	1	QPSK	3/4	2	104	216	78	162	19.5	40.5	21.700	45
3	1	16-QAM	1/2	4	208	432	104	216	26.0	54.0	28.900	60
4	1	16-QAM	3/4	4	208	432	156	324	39.0	81.0	43.300	90
5	1	64-QAM	2/3	6	312	648	208	432	52.0	108.0	57.800	120
6	1	64-QAM	3/4	6	312	648	234	486	58.5	121.5	65.000	135
7	1	64-QAM	5/6	6	312	648	260	540	65.0	135.0	72.200	150

Symbol	Explanation
NSS	Number of spatial streams
R	Code rate
NBPS	Number of coded bits per single carrier
NCBPS	Number of coded bits per symbol
NDBPS	Number of data bits per symbol
GI	guard interval

3.2. Accessories

N/A

3.3. Table for Filed Antenna

Chain	Brand	Model Name	Antenna Type	Connector	Gain (dBi)	Remark
1	MAG.LAYERS	EDA-8709-25GR2-A9	Omni-directional Antenna	I-PEX	2	TX / RX
2	MAG.LAYERS	EDA-8709-25GR2-A9	Omni-directional Antenna	I-PEX	2	TX / RX

Note: The EUT has two Chains.

Chain 1 and Chain 2 could transmit/receive simultaneously.

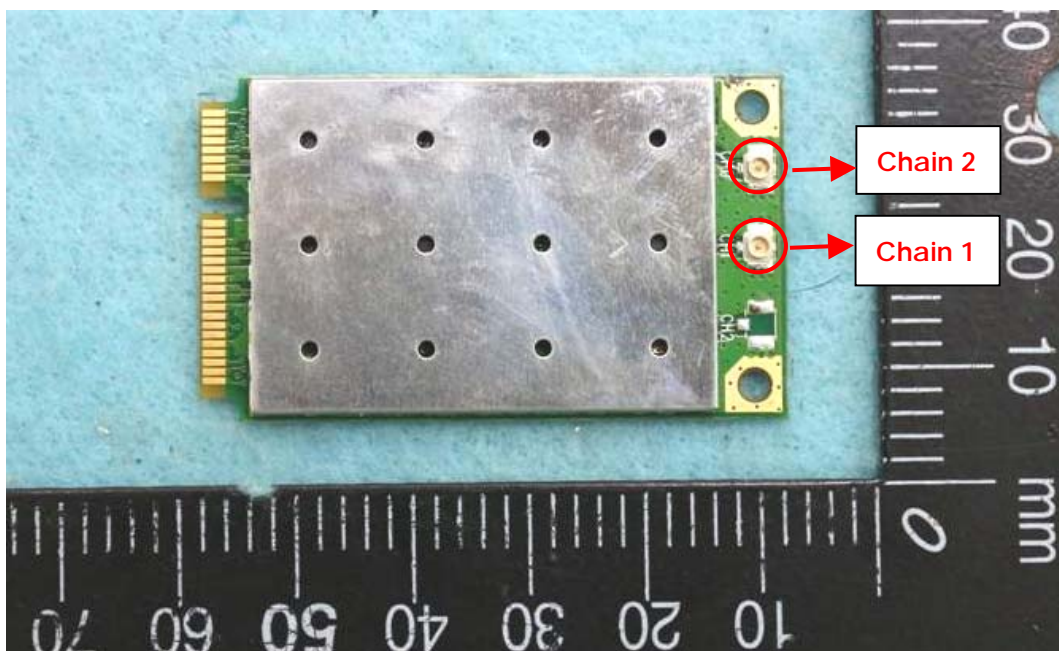

3.4. Table for Carrier Frequencies

For IEEE 802.11a, use Channel 36, 40, 44, 48, 52, 56, 60, 64, 100, 104, 108, 112, 116, 132, 136, 140.

There are two bandwidth systems for IEEE 802.11n.

For both 20MHz bandwidth systems, use Channel 36, 40, 44, 48, 52, 56, 60, 64, 100, 104, 108, 112, 116, 132, 136, 140.

For both 40MHz bandwidth systems, use Channel 38, 46, 54, 62, 102, 110, 134.

Frequency Band	Channel No.	Frequency	Channel No.	Frequency
5150~5250 MHz Band 1	36	5180 MHz	44	5220 MHz
	38	5190 MHz	46	5230 MHz
	40	5200 MHz	48	5240 MHz
5250~5350 MHz Band 2	52	5260 MHz	60	5300 MHz
	54	5270 MHz	62	5310 MHz
	56	5280 MHz	64	5320 MHz
5470~5725 MHz Band 3	100	5500 MHz	116	5580 MHz
	102	5510MHz	132	5660 MHz
	104	5520 MHz	134	5670 MHz
	108	5540 MHz	136	5680 MHz
	110	5550 MHz	140	5700 MHz
	112	5560 MHz	-	-

3.5. Table for Test Modes

Preliminary tests were performed in different data rate to find the worst radiated emission. The data rate shown in the table below is the worst-case rate with respect to the specific test item. Investigation has been done on all the possible configurations for searching the worst cases. The following table is a list of the test modes shown in this test report.

Test Items	Mode		Data Rate	Channel	Chain
AC Power Conducted Emission	Normal Link		Auto	-	-
Max. Conducted Output Power	MCS0/20MHz	Band 1~2	6.5Mbps	36/40/48/52/60/64	1+2
		Band 3	6.5Mbps	100/116/140	1+2
	MCS0/40MHz	Band 1~2	13.5Mbps	38/46/54/62	1+2
		Band 3	13.5Mbps	102/110/134	1+2
	11a/BPSK	Band 1~2	6Mbps	36/40/48/52/60/64	1+2
		Band 3	6Mbps	100/116/140	1+2
Power Spectral Density	MCS0/20MHz	Band 1~2	6.5Mbps	36/40/48/52/60/64	1+2
		Band 3	6.5Mbps	100/116/140	1+2
	MCS0/40MHz	Band 1~2	13.5Mbps	38/46/54/62	1+2
		Band 3	13.5Mbps	102/110/134	1+2
	11a/BPSK	Band 1~2	6Mbps	36/40/48/52/60/64	1+2
		Band 3	6Mbps	100/116/140	1+2
26dB Spectrum Bandwidth 99% Occupied Bandwidth Measurement Peak Excursion	MCS0/20MHz	Band 1~2	6.5Mbps	36/40/48/52/60/64	1+2
		Band 3	6.5Mbps	100/116/140	1+2
	MCS0/40MHz	Band 1~2	13.5Mbps	38/46/54/62	1+2
		Band 3	13.5Mbps	102/110/134	1+2
	11a/BPSK	Band 1~2	6Mbps	36/40/48/52/60/64	1+2
		Band 3	6Mbps	100/116/140	1+2
Radiated Emission Below 1GHz	Normal Link		Auto	-	-
Radiated Emission Above 1GHz	MCS0/20MHz	Band 1~2	6.5Mbps	36/40/48/52/60/64	1+2
		Band 3	6.5Mbps	100/116/140	1+2
	MCS0/40MHz	Band 1~2	13.5Mbps	38/46/54/62	1+2
		Band 3	13.5Mbps	102/110/134	1+2
	11a/BPSK	Band 1~2	6Mbps	36/40/48/52/60/64	1+2
		Band 3	6Mbps	100/116/140	1+2
Band Edge Emission	MCS0/20MHz	Band 1~2	6.5Mbps	36/40/48/52/60/64	1+2
		Band 3	6.5Mbps	100/140	1+2
	MCS0/40MHz	Band 1~2	13.5Mbps	38/46/54/62	1+2

		Band 3	13.5Mbps	102/110/134	1+2
	11a/BPSK	Band 1~2	6Mbps	36/40/48/52/60/64	1+2
		Band 3	6Mbps	100/140	1+2
Frequency Stability	Un-modulation		-	40/60	N/A

3.6. Table for Testing Locations

Test Site No.	Site Category	Location	FCC Reg. No.	IC File No.	VCCI Reg. No
03CH01-CB	SAC	Hsin Chu	262045	IC 4086D	-
CO01-CB	Conduction	Hsin Chu	262045	IC 4086D	-
TH01-CB	OVEN Room	Hsin Chu	-	-	-

Open Area Test Site (OATS); Semi Anechoic Chamber (SAC).

Please refer section 6 for Test Site Address.

3.7. Table for Supporting Units

For Conducted Emission test:

Support Unit	Brand	Model	FCC ID
Notebook	DELL	1200	E2K4965AGNM
Mouse	Logitech	M-U0026	DoC
Earphone	SHYARO CHI	MIC-04	N/A
Wireless AP	Planex	GW-AP54SGX	N/A

For Radiated Emission test:

Support Unit	Brand	Model	FCC ID
Notebook	DELL	E6220	N/A
Mouse	Logitech	M-U0026	DoC
Earphone	SHYARO CHI	MIC-04	N/A
Wireless AP	Planex	GW-AP54SGX	N/A

For 26dB Spectrum Bandwidth, Maximum Conducted Output Power, Power Spectral Density,

Peak Excursion and Frequency Stability test:

Support Unit	Brand	Model	FCC ID
Notebook	DELL	M1330	E2KWM3945ABG

3.8. Table for Parameters of Test Software Setting

During testing, Channel & Power Controlling Software provided by the customer was used to control the operating channel as well as the output power level. The RF output power selection is for the setting of RF output power expected by the customer and is going to be fixed on the firmware of the final end product.

Power Parameters of IEEE 802.11n MCS0 20MHz / Chain 1 + Chain 2 (2TX)

Test Software Version	ART2-GUI Version 2.3								
Frequency	5180 MHz	5200 MHz	5240 MHz	5260 MHz	5300 MHz	5320 MHz	5500 MHz	5580 MHz	5700 MHz
MCS0 20MHz	10.5	11	10.5	19.5	20	17	16.5	22.5	12

Power Parameters of IEEE 802.11n MCS0 40MHz / Chain 1 + Chain 2 (2TX)

Test Software Version	ART2-GUI Version 2.3						
Frequency	5190 MHz	5230 MHz	5270 MHz	5310 MHz	5510 MHz	5550 MHz	5670 MHz
MCS0 40MHz	10	10.5	19	12	14	22.5	17.5

Power Parameters of IEEE 802.11a / Chain 1 + Chain 2 (2TX)

Test Software Version	ART2-GUI Version 2.3								
Frequency	5180 MHz	5200 MHz	5240 MHz	5260 MHz	5300 MHz	5320 MHz	5500 MHz	5580 MHz	5700 MHz
IEEE 802.11a	10	10	10.5	20	20	16.5	16.5	23	13.5

During the test, "ART2-GUI Version 2.3" under WIN XP was executed the test program to control the EUT continuously transmit RF signal.

3.9. Test Configurations

3.9.1. Radiation Emissions Test Configuration

Test Configuration: 30 MHz ~ 1 GHz

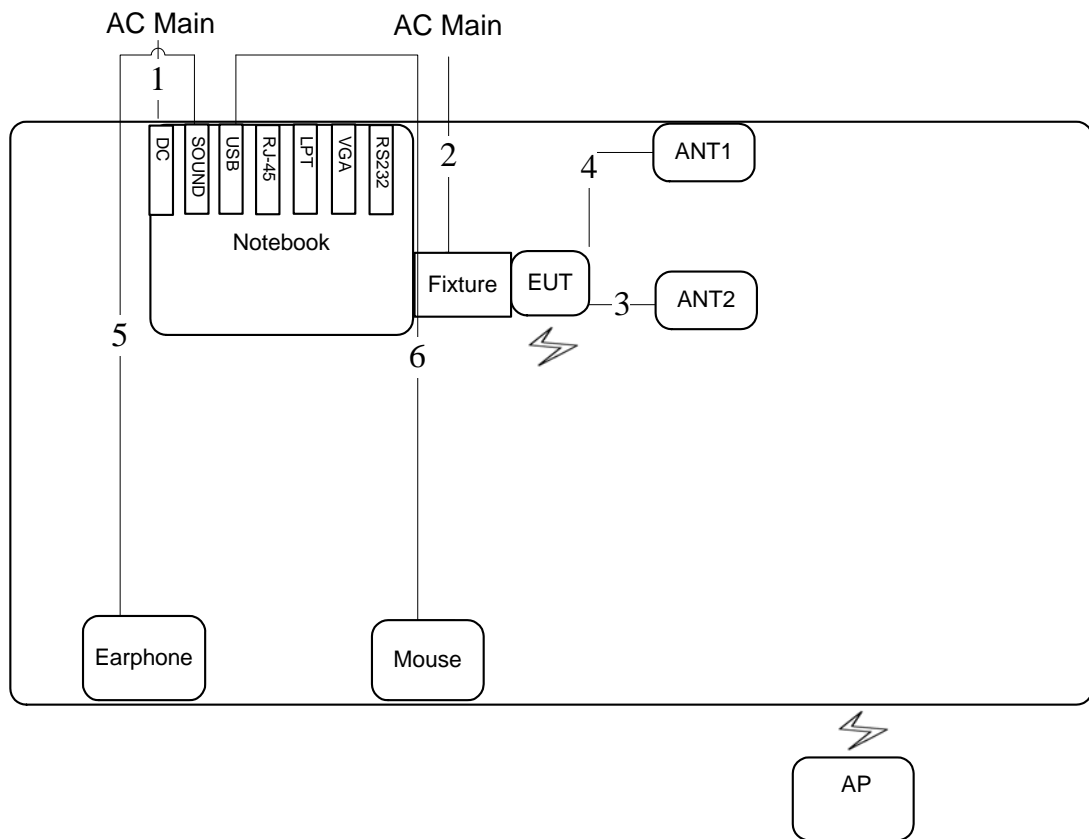

Item	Connection	Shield	Length
1	Power cable	No	1.8m
2	Power cable	No	1.5m
3	Antenna cable	Yes	0.1m
4	Antenna cable	Yes	0.1m
5	Audio cable	No	1.1m
6	USB cable	No	1.5m

Test Configuration: above 1 GHz

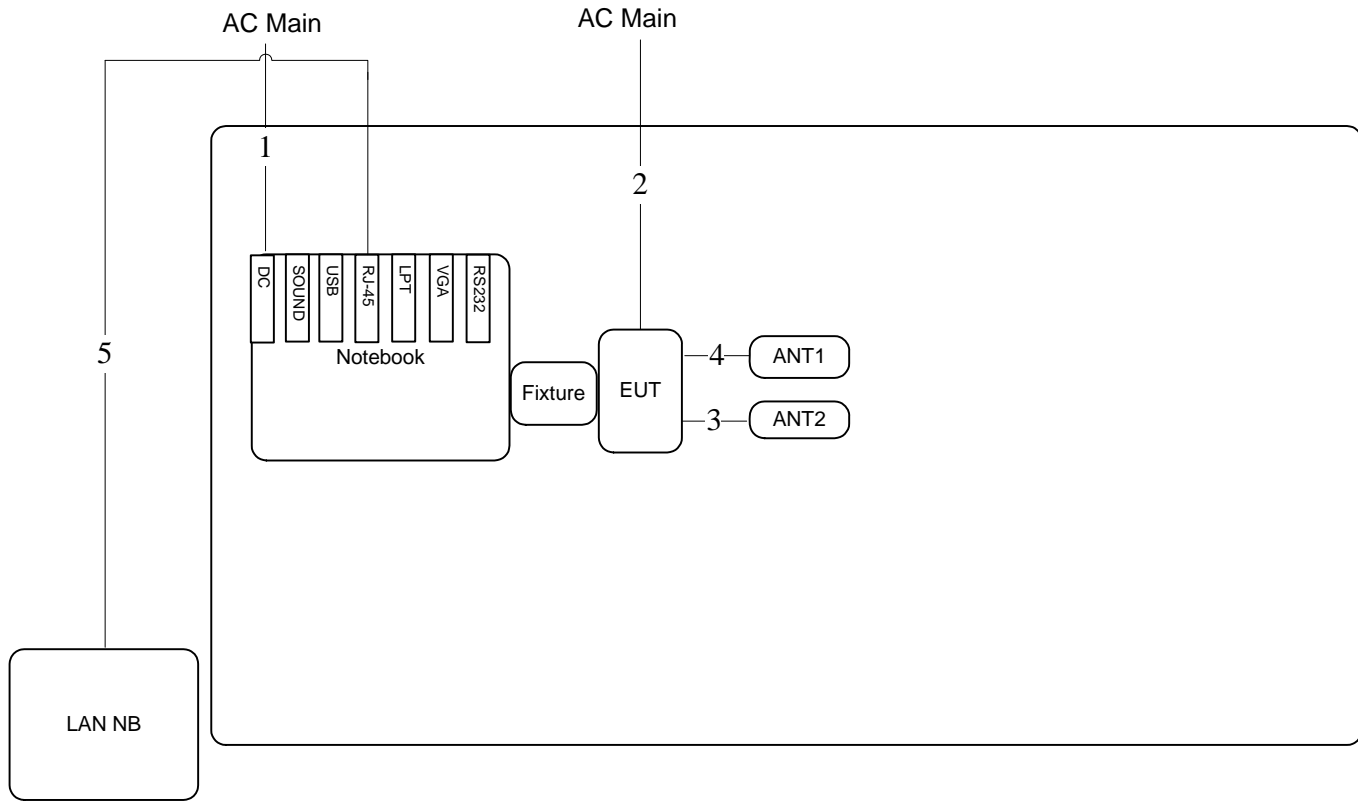

Item	Connection	Shield	Length
1	Power cable	No	1.8m
2	Power cable	No	1.5m
3	Antenna cable	Yes	0.1m
4	Antenna cable	Yes	0.1m
5	RJ-45 cable	No	10m

3.9.2. AC Power Line Conduction Emissions Test Configuration

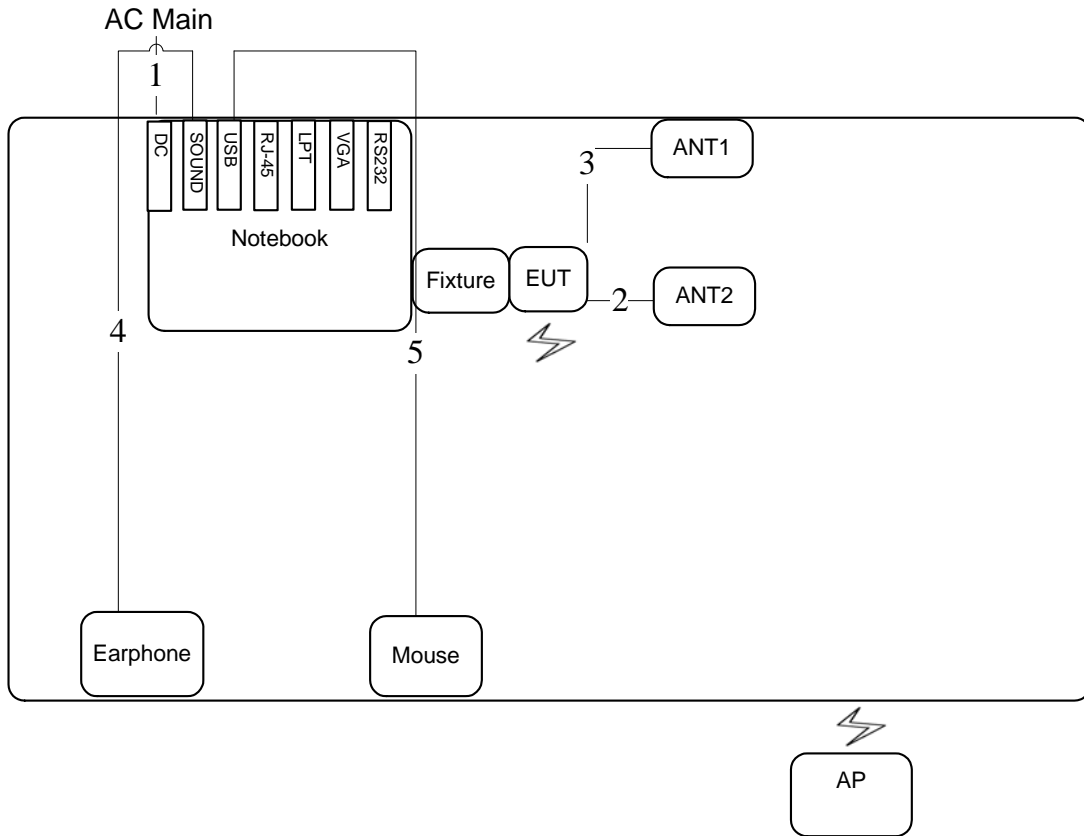

Item	Connection	Shield	Length
1	Power cable	No	1.8m
2	Antenna cable	Yes	0.1m
3	Antenna cable	Yes	0.1m
4	Audio cable	No	1.1m
5	USB cable	No	1.5m

4. TEST RESULT

4.1. AC Power Line Conducted Emissions Measurement

4.1.1. Limit

For this product that is designed to connect to the AC power line, the radio frequency voltage that is conducted back onto the AC power line on any frequency or frequencies within the band 150 kHz to 30 MHz shall not exceed below limits table.

Frequency (MHz)	QP Limit (dBuV)	AV Limit (dBuV)
0.15~0.5	66~56	56~46
0.5~5	56	46
5~30	60	50

4.1.2. Measuring Instruments and Setting

Please refer to section 5 of equipments list in this report. The following table is the setting of the receiver.

Receiver Parameters	Setting
Attenuation	10 dB
Start Frequency	0.15 MHz
Stop Frequency	30 MHz
IF Bandwidth	9 KHz

4.1.3. Test Procedures

1. Configure the EUT according to ANSI C63.10. The EUT or host of EUT has to be placed 0.4 meter far from the conducting wall of the shielding room and at least 80 centimeters from any other grounded conducting surface.
2. Connect EUT or host of EUT to the power mains through a line impedance stabilization network (LISN).
3. All the support units are connected to the other LISNs. The LISN should provide 50uH/50ohms coupling impedance.
4. The frequency range from 150 KHz to 30 MHz was searched.
5. Set the test-receiver system to Peak Detect Function and Specified Bandwidth with Maximum Hold Mode.
6. The measurement has to be done between each power line and ground at the power terminal.

4.1.4. Test Setup Layout

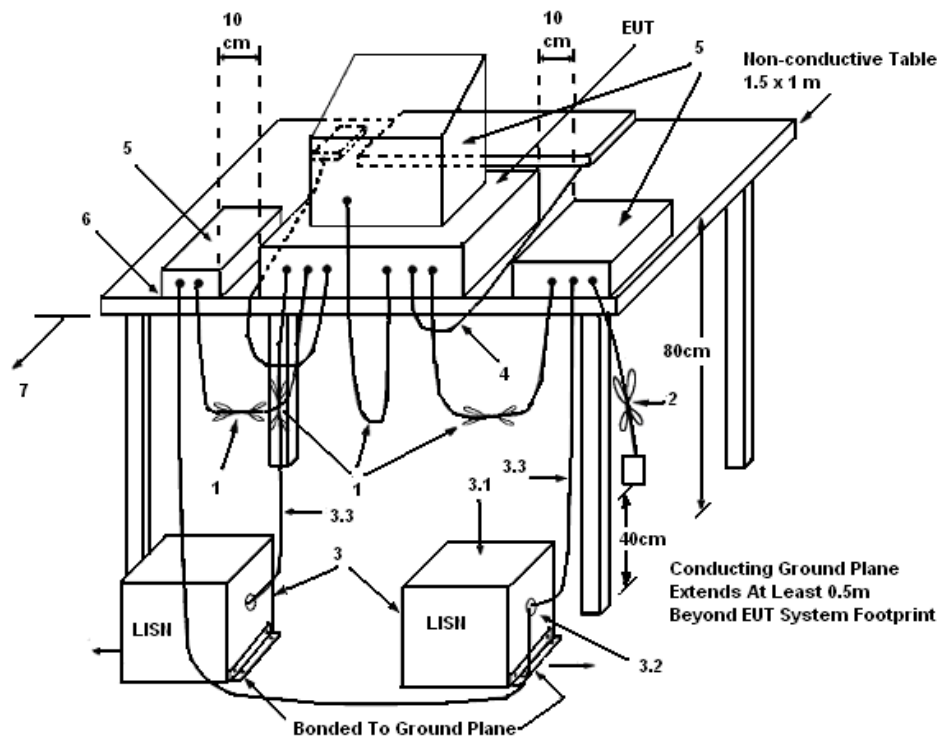

LEGEND:

- (1) Interconnecting cables that hang closer than 40 cm to the ground plane shall be folded back and forth in the center forming a bundle 30 to 40 cm long.
- (2) I/O cables that are not connected to a peripheral shall be bundled in the center. The end of the cable may be terminated, if required, using the correct terminating impedance. The overall length shall not exceed 1 m.
- (3) EUT connected to one LISN. Unused LISN measuring port connectors shall be terminated in 50 Ω . LISN can be placed on top of, or immediately beneath, reference ground plane.
 - (3.1) All other equipment powered from additional LISN(s).
 - (3.2) Multiple outlet strip can be used for multiple power cords of non-EUT equipment.
 - (3.3) LISN at least 80 cm from nearest part of EUT chassis.
- (4) Cables of hand-operated devices, such as keyboards, mice, etc., shall be placed as for normal use.
- (5) Non-EUT components of EUT system being tested.
- (6) Rear of EUT, including peripherals, shall all be aligned and flush with rear of tabletop.
- (7) Rear of tabletop shall be 40 cm removed from a vertical conducting plane that is bonded to the ground plane.

4.1.5. Test Deviation

There is no deviation with the original standard.

4.1.6. EUT Operation during Test

The EUT was placed on the test table and programmed in normal function.

4.1.7. Results of AC Power Line Conducted Emissions Measurement

Temperature	24°C	Humidity	60%
Test Engineer	Hank Yang	Phase	Line
Configuration	Normal Link		

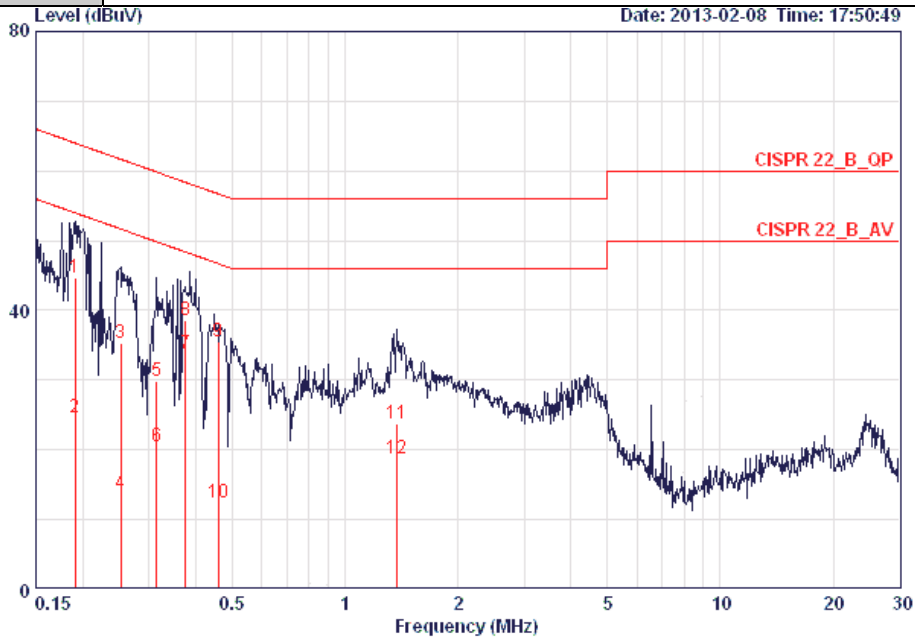

	Freq	Level	Over Limit	Limit Line	Read Level	LISN Factor	Cable Loss	Remark
	MHz	dBuV	dB	dBuV	dBuV	dB	dB	
1	0.19039	44.70	-19.32	64.02	44.35	0.15	0.20	QP
2	0.19039	24.69	-29.33	54.02	24.34	0.15	0.20	AVERAGE
3	0.25211	35.30	-26.39	61.69	34.95	0.15	0.20	QP
4	0.25211	13.68	-38.01	51.69	13.33	0.15	0.20	AVERAGE
5	0.31495	29.87	-29.97	59.84	29.52	0.15	0.20	QP
6	0.31495	20.42	-29.42	49.84	20.07	0.15	0.20	AVERAGE
7	0.37578	33.83	-14.54	48.37	33.48	0.15	0.20	AVERAGE
8	0.37578	38.48	-19.89	58.37	38.13	0.15	0.20	QP
9	0.45878	35.53	-21.18	56.71	35.18	0.15	0.20	QP
10	0.45878	12.48	-34.23	46.71	12.13	0.15	0.20	AVERAGE
11	1.374	23.74	-32.26	56.00	23.35	0.18	0.21	QP
12	1.374	18.65	-27.35	46.00	18.26	0.18	0.21	AVERAGE

Temperature	24°C	Humidity	60%
Test Engineer	Hank Yang	Phase	Neutral
Configuration	Normal Link		

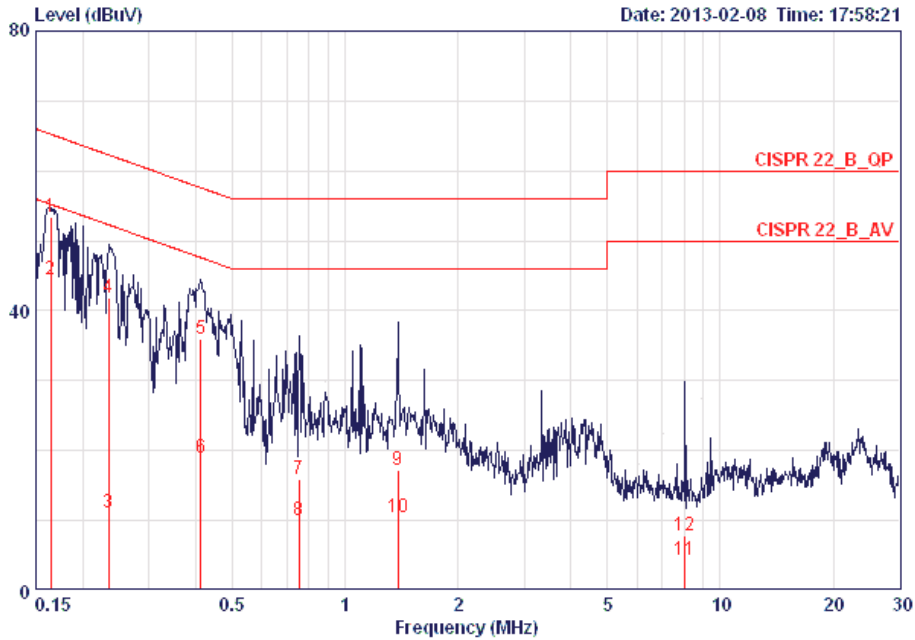

	Freq	Level	Over Limit	Limit Line	Read Level	LISN Factor	Cable Loss	Remark
	MHz	dBuV	dB	dBuV	dBuV	dB	dB	
1	0.16414	53.45	-11.81	65.25	53.18	0.08	0.19	QP
2	0.16414	44.52	-10.74	55.25	44.25	0.08	0.19	AVERAGE
3	0.23409	11.16	-41.14	52.30	10.88	0.08	0.20	AVERAGE
4	0.23409	41.96	-20.34	62.30	41.68	0.08	0.20	QP
5	0.41266	36.06	-21.53	57.59	35.78	0.08	0.20	QP
6	0.41266	18.86	-28.73	47.59	18.58	0.08	0.20	AVERAGE
7	0.75493	15.93	-40.07	56.00	15.64	0.09	0.20	QP
8	0.75493	10.13	-35.87	46.00	9.84	0.09	0.20	AVERAGE
9	1.381	17.22	-38.78	56.00	16.91	0.10	0.21	QP
10	1.381	10.52	-35.48	46.00	10.21	0.10	0.21	AVERAGE
11	8.062	4.28	-45.72	50.00	3.78	0.20	0.30	AVERAGE
12	8.062	7.76	-52.24	60.00	7.26	0.20	0.30	QP

Note:

Level = Read Level + LISN Factor + Cable Loss.

4.2. 99% Occupied Bandwidth Measurement

4.2.1. Limit

No restriction limits. But resolution bandwidth within band edge measurement is 1% of the 99% occupied bandwidth.

4.2.2. Measuring Instruments and Setting

Please refer to section 5 of equipments list in this report. The following table is the setting of the spectrum analyzer.

Spectrum Parameters	Setting
Attenuation	Auto
Span Frequency	> 26dB Bandwidth
RB	Approximately 1% of the emission bandwidth
VB	VBW > RBW
Detector	Peak
Trace	Max Hold
Sweep Time	Auto

4.2.3. Test Procedures

1. The transmitter output (antenna port) was connected to the spectrum analyzer in peak hold mode.
2. The resolution bandwidth of 300 kHz and the video bandwidth of 1000 kHz were used.
3. Measured the spectrum width with power higher than 26dB below carrier.

4.2.4. Test Setup Layout

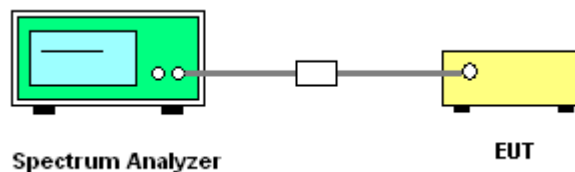

4.2.5. Test Deviation

There is no deviation with the original standard.

4.2.6. EUT Operation during Test

The EUT was programmed to be in continuously transmitting mode.

4.2.7. Test Result of 99% Occupied Bandwidth

Temperature	25°C	Humidity	56%
Test Engineer	Benson Peng	Configurations	IEEE 802.11n

Configuration IEEE 802.11n MCS0 20MHz / Chain 1+ Chain 2 (2TX)

Channel	Frequency	26dB Bandwidth (MHz)	99% Occupied Bandwidth (MHz)
36	5180 MHz	22.88	18.40
40	5200 MHz	23.04	18.40
48	5240 MHz	23.36	18.40
52	5260 MHz	35.20	22.88
60	5300 MHz	35.20	23.04
64	5320 MHz	27.84	18.88
100	5500 MHz	25.12	18.40
116	5580 MHz	36.32	24.64
140	5700 MHz	22.88	18.40

Configuration IEEE 802.11n MCS0 40MHz / Chain 1+ Chain 2 (2TX)

Channel	Frequency	26dB Bandwidth (MHz)	99% Occupied Bandwidth (MHz)
38	5190 MHz	42.24	36.80
46	5230 MHz	43.20	36.48
54	5270 MHz	75.20	38.08
62	5310 MHz	43.84	37.12
102	5510MHz	42.88	36.80
110	5550 MHz	77.44	52.16
134	5670 MHz	61.44	36.48

Temperature	25°C	Humidity	56%
Test Engineer	Benson Peng	Configurations	IEEE 802.11a

Configuration IEEE 802.11a / Chain 1+ Chain 2 (2TX)

Channel	Frequency	26dB Bandwidth (MHz)	99% Occupied Bandwidth (MHz)
36	5180 MHz	20.80	16.16
40	5200 MHz	20.32	16.32
48	5240 MHz	21.76	17.12
52	5260 MHz	36.80	21.44
60	5300 MHz	39.68	21.12
64	5320 MHz	25.76	17.60
100	5500 MHz	24.96	17.12
116	5580 MHz	36.96	25.44
140	5700 MHz	22.08	16.64

26 dB Bandwidth Plot on Configuration IEEE 802.11n MCS0 20MHz / Chain 1+ Chain 2 (2TX) / 5180 MHz

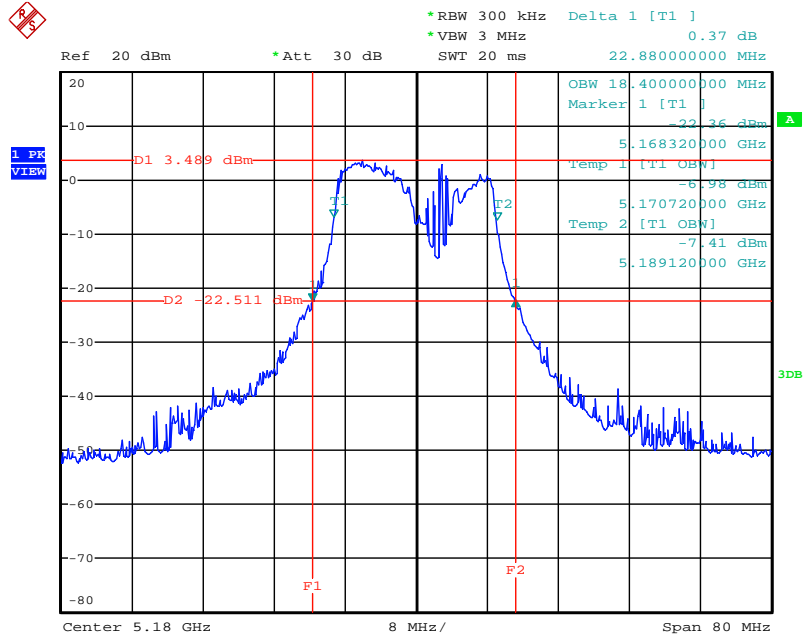

Date: 7.FEB.2013 07:24:36

26 dB Bandwidth Plot on Configuration IEEE 802.11n MCS0 20MHz / Chain 1+ Chain 2 (2TX) / 5200 MHz

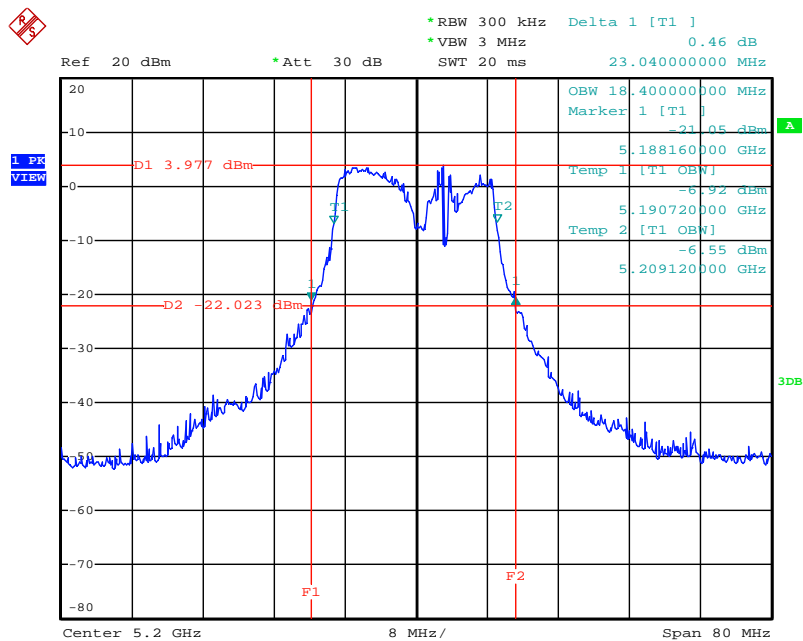

Date: 7.FEB.2013 07:25:25

26 dB Bandwidth Plot on Configuration IEEE 802.11n MCS0 20MHz / Chain 1+ Chain 2 (2TX) / 5240 MHz

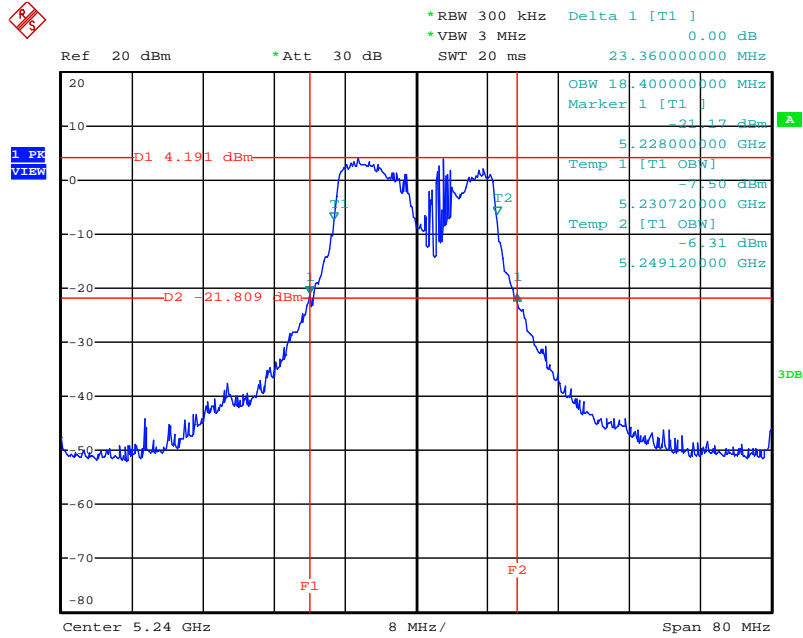

Date: 7.FEB.2013 07:25:56

26 dB Bandwidth Plot on Configuration IEEE 802.11n MCS0 20MHz / Chain 1+ Chain 2 (2TX) / 5260 MHz

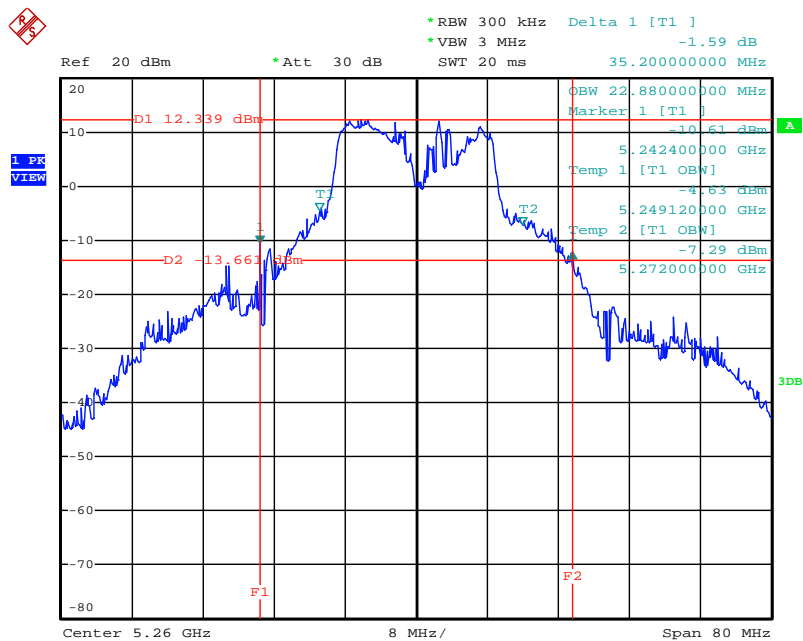

Date: 7.FEB.2013 07:26:46

26 dB Bandwidth Plot on Configuration IEEE 802.11n MCS0 20MHz / Chain 1+ Chain 2 (2TX) / 5300 MHz

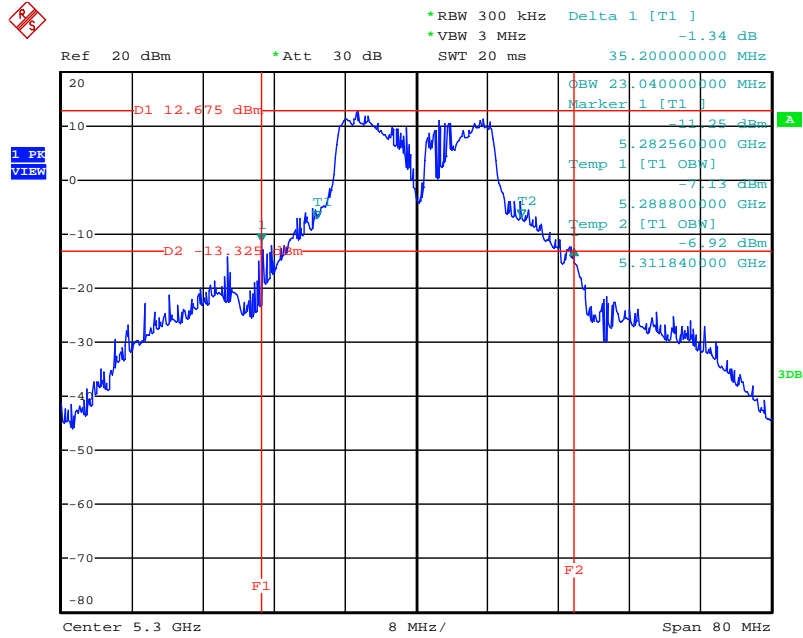

Date: 7.FEB.2013 07:27:11

26 dB Bandwidth Plot on Configuration IEEE 802.11n MCS0 20MHz / Chain 1+ Chain 2 (2TX) / 5320 MHz

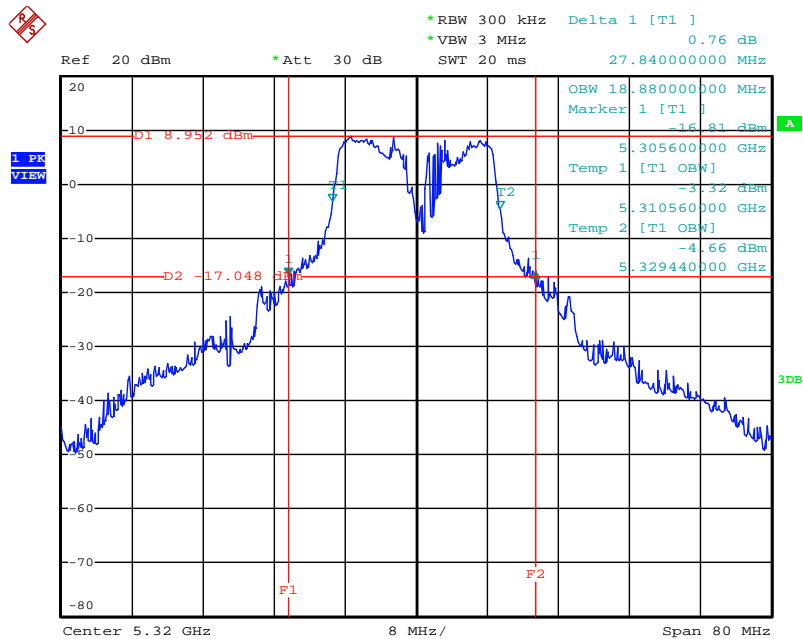

Date: 7.FEB.2013 07:27:43

26 dB Bandwidth Plot on Configuration IEEE 802.11n MCS0 20MHz / Chain 1+ Chain 2 (2TX) / 5500 MHz

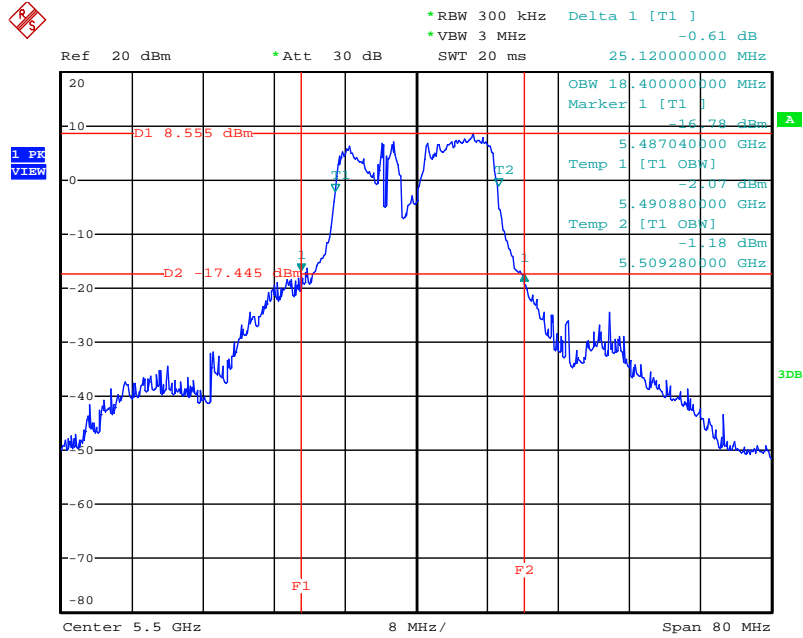

Date: 7.FEB.2013 07:28:34

26 dB Bandwidth Plot on Configuration IEEE 802.11n MCS0 20MHz / Chain 1+ Chain 2 (2TX) / 5580 MHz

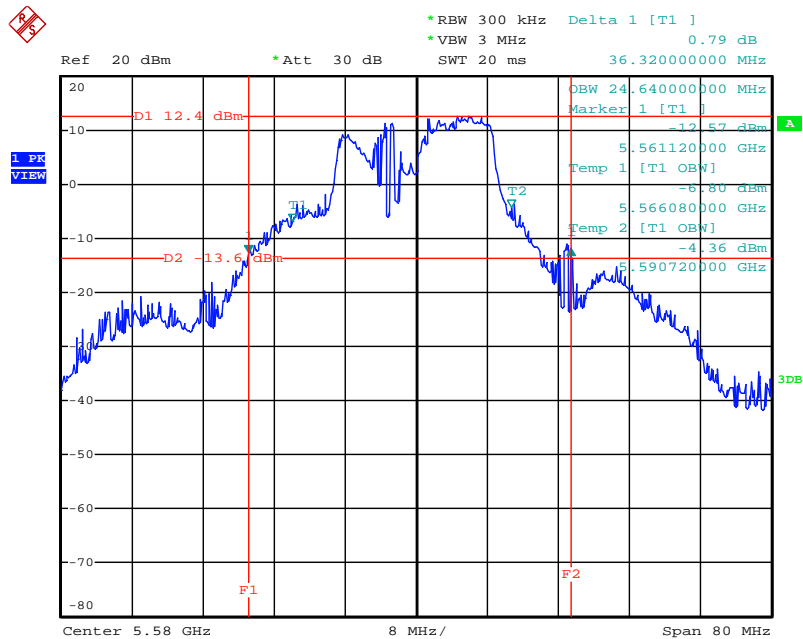

Date: 7.FEB.2013 07:29:22

26 dB Bandwidth Plot on Configuration IEEE 802.11n MCS0 20MHz / Chain 1+ Chain 2 (2TX) / 5700 MHz

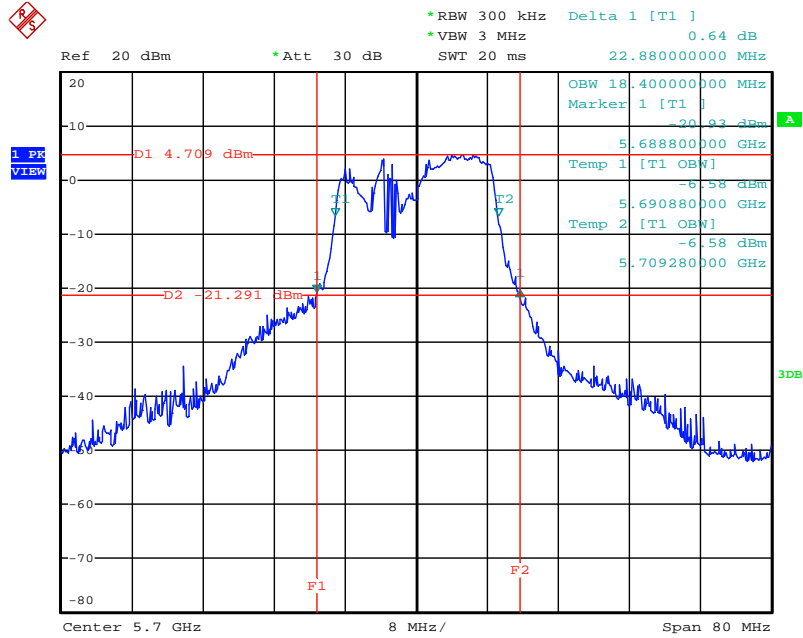

Date: 7.FEB.2013 07:29:59

26 dB Bandwidth Plot on Configuration IEEE 802.11n MCS0 40MHz / Chain 1+ Chain 2 (2TX) / 5190 MHz

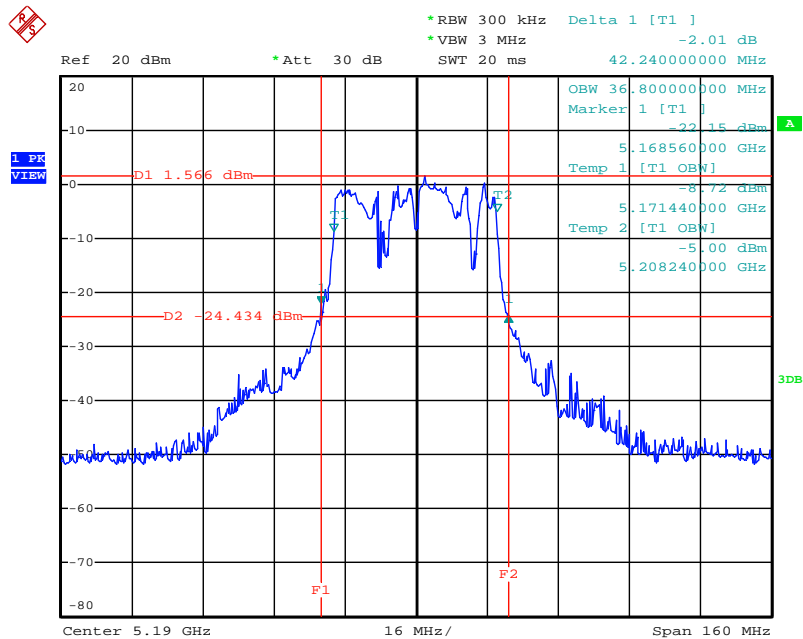

Date: 7.FEB.2013 07:30:51

26 dB Bandwidth Plot on Configuration IEEE 802.11n MCS0 40MHz / Chain 1+ Chain 2 (2TX) / 5230 MHz

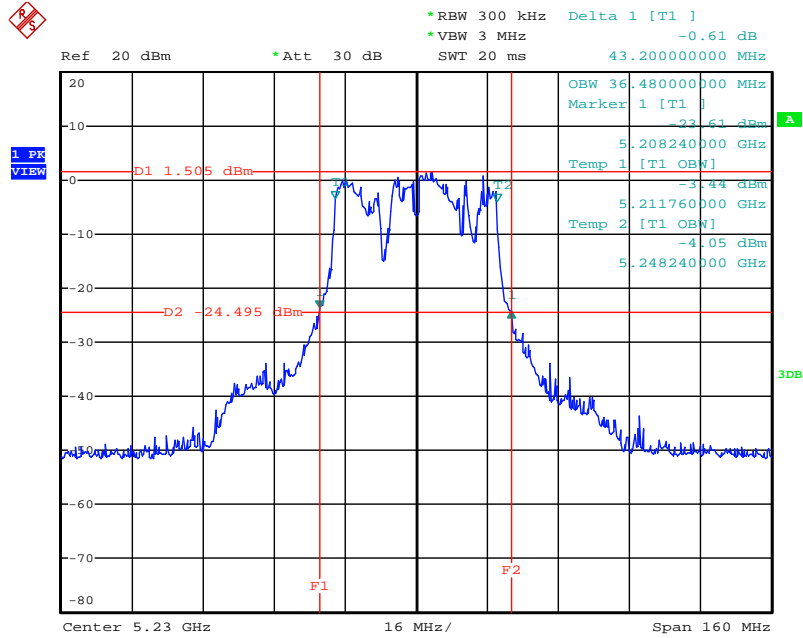

Date: 7.FEB.2013 07:31:27

26 dB Bandwidth Plot on Configuration IEEE 802.11n MCS0 40MHz / Chain 1+ Chain 2 (2TX) / 5270 MHz

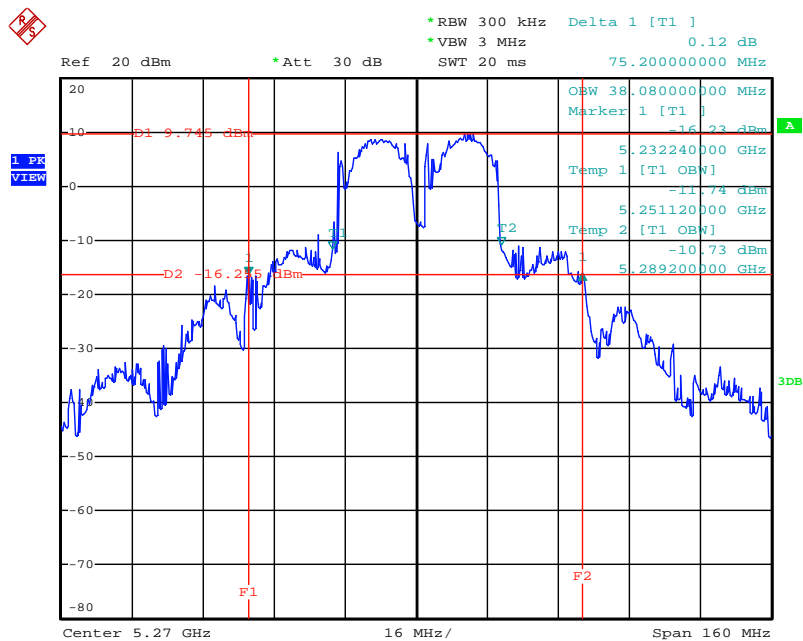

Date: 7.FEB.2013 07:32:38

26 dB Bandwidth Plot on Configuration IEEE 802.11n MCS0 40MHz / Chain 1+ Chain 2 (2TX) / 5310 MHz

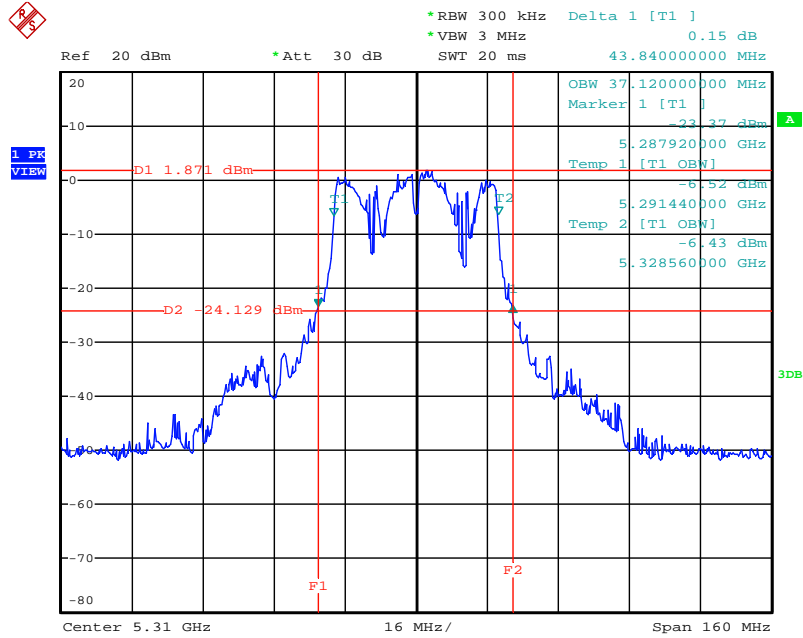

Date: 7.FEB.2013 07:33:15

26 dB Bandwidth Plot on Configuration IEEE 802.11n MCS0 40MHz / Chain 1+ Chain 2 (2TX) / 5510MHz

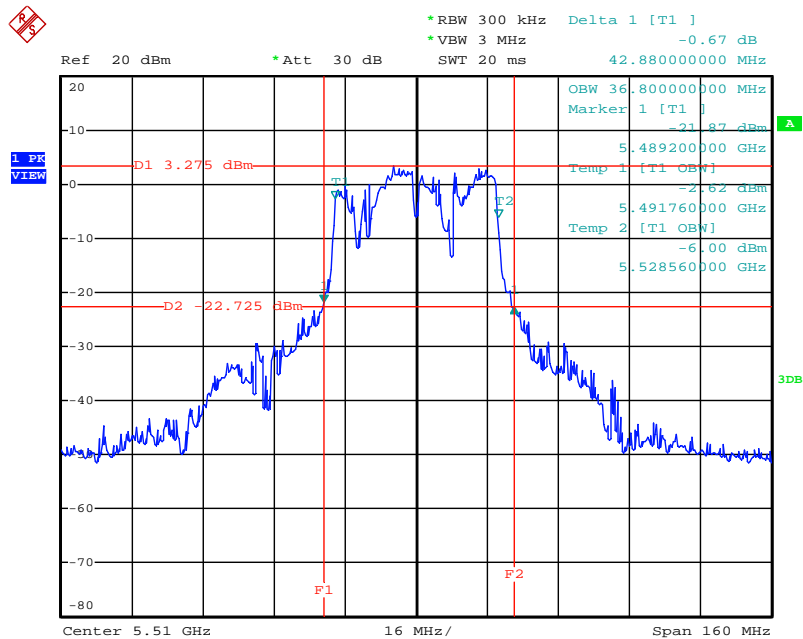

Date: 7.FEB.2013 07:33:50

26 dB Bandwidth Plot on Configuration IEEE 802.11n MCS0 40MHz / Chain 1+ Chain 2 (2TX) / 5550 MHz

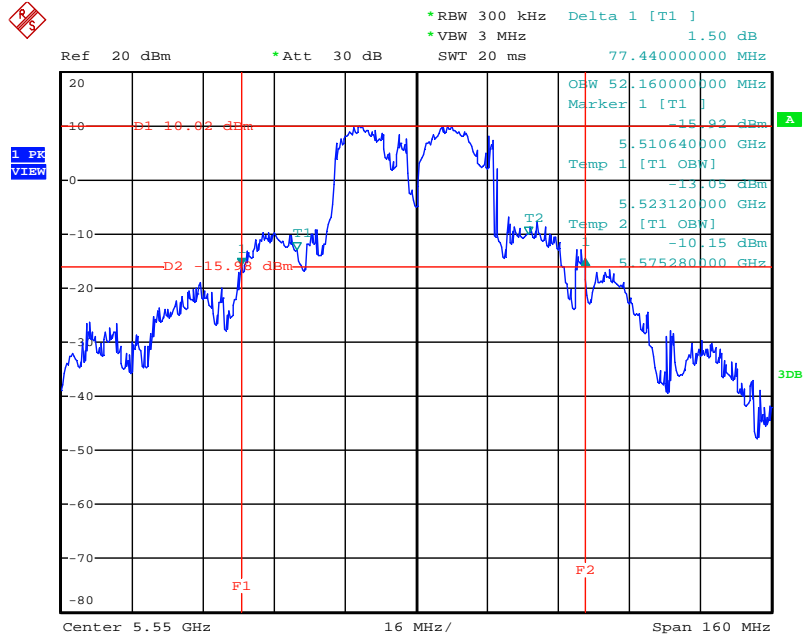

Date: 7.FEB.2013 07:34:26

26 dB Bandwidth Plot on Configuration IEEE 802.11n MCS0 40MHz / Chain 1+ Chain 2 (2TX) / 5670 MHz

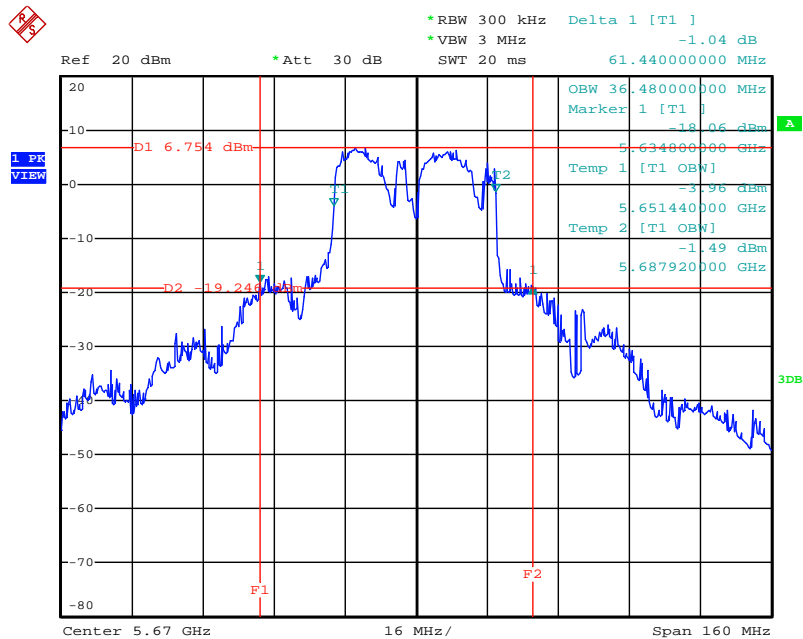

Date: 7.FEB.2013 07:35:01

26 dB Bandwidth Plot on Configuration IEEE 802.11a / Chain 1+ Chain 2 (2TX) / 5180 MHz

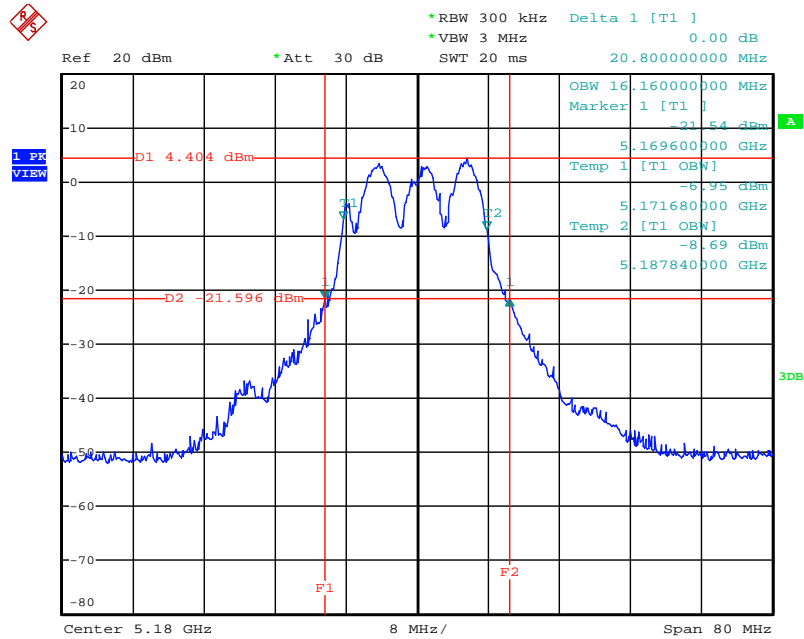

Date: 7.FEB.2013 07:07:47

26 dB Bandwidth Plot on Configuration IEEE 802.11a / Chain 1+ Chain 2 (2TX) / 5200 MHz

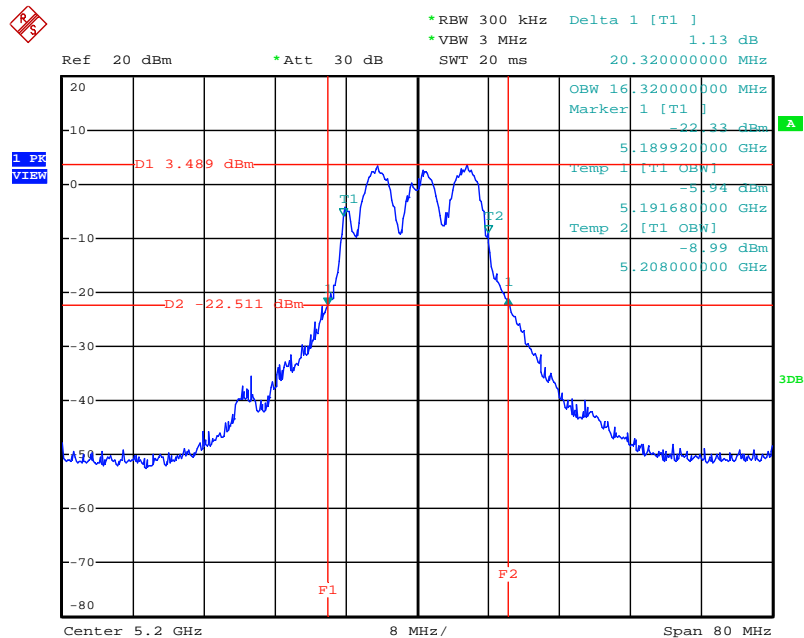

Date: 7.FEB.2013 07:09:26

26 dB Bandwidth Plot on Configuration IEEE 802.11a / Chain 1+ Chain 2 (2TX) / 5240 MHz

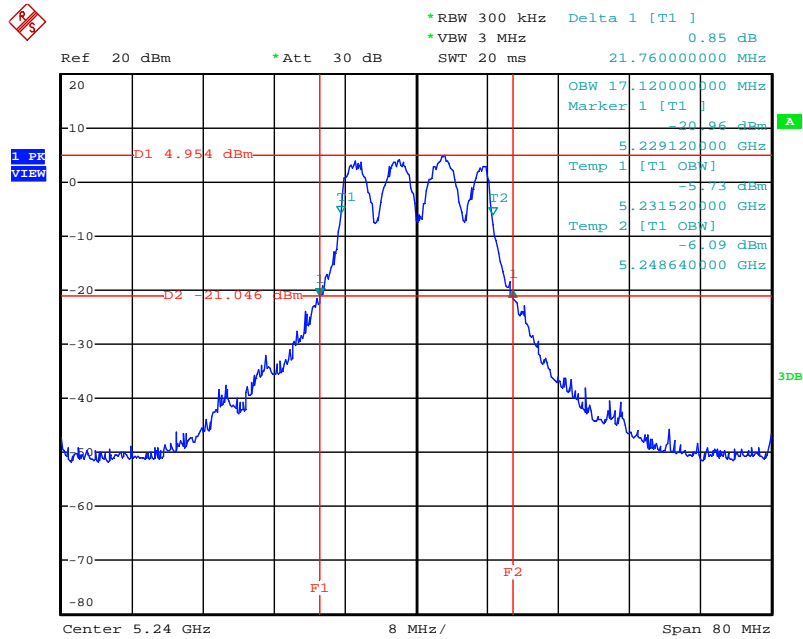

Date: 7.FEB.2013 07:13:25

26 dB Bandwidth Plot on Configuration IEEE 802.11a / Chain 1+ Chain 2 (2TX) / 5260 MHz

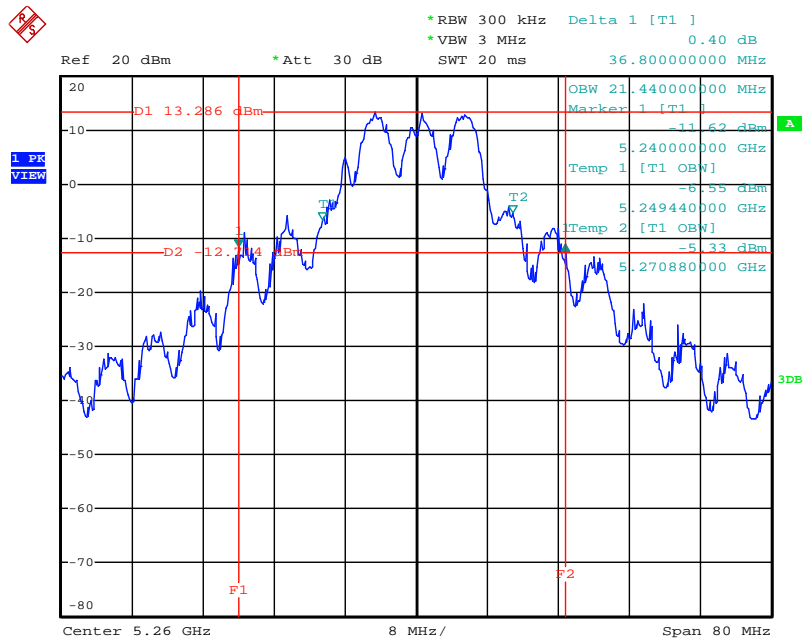

Date: 7.FEB.2013 07:14:05

26 dB Bandwidth Plot on Configuration IEEE 802.11a / Chain 1+ Chain 2 (2TX) / 5300 MHz

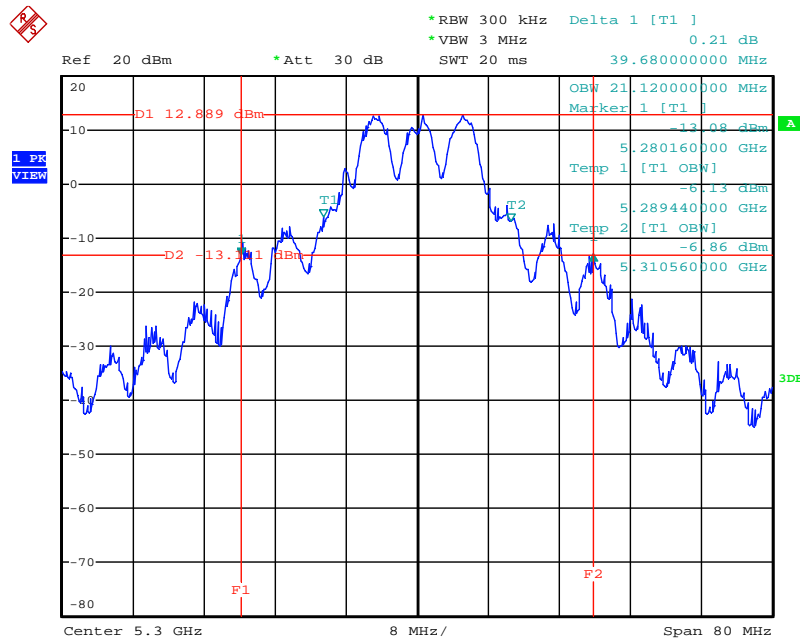

Date: 7.FEB.2013 07:15:04

26 dB Bandwidth Plot on Configuration IEEE 802.11a / Chain 1+ Chain 2 (2TX) / 5320 MHz

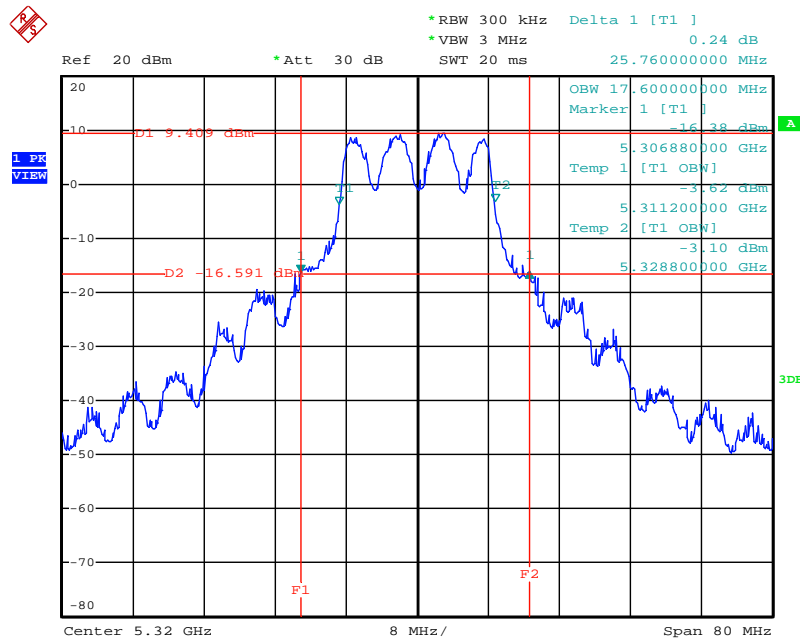

Date: 7.FEB.2013 07:15:35

26 dB Bandwidth Plot on Configuration IEEE 802.11a / Chain 1+ Chain 2 (2TX) / 5500 MHz

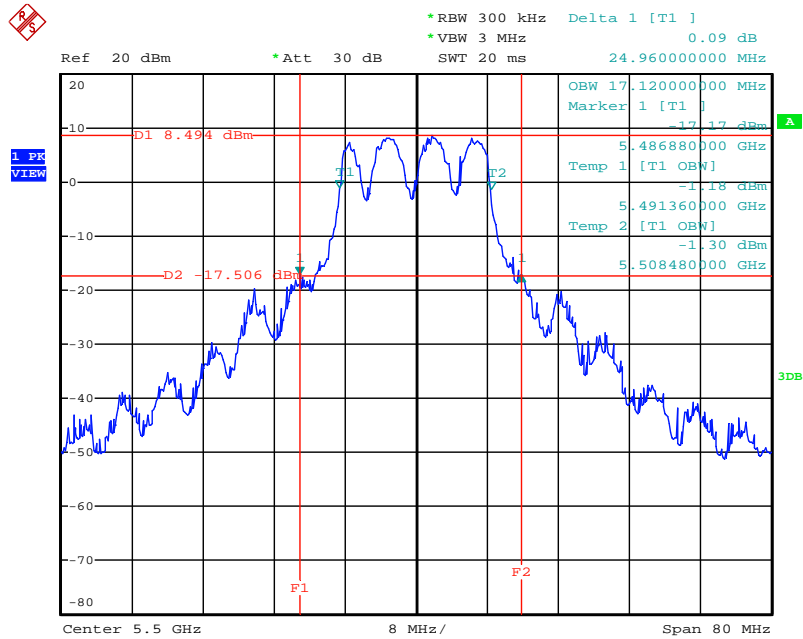

Date: 7.FEB.2013 07:21:44

26 dB Bandwidth Plot on Configuration IEEE 802.11a / Chain 1+ Chain 2 (2TX) / 5580 MHz

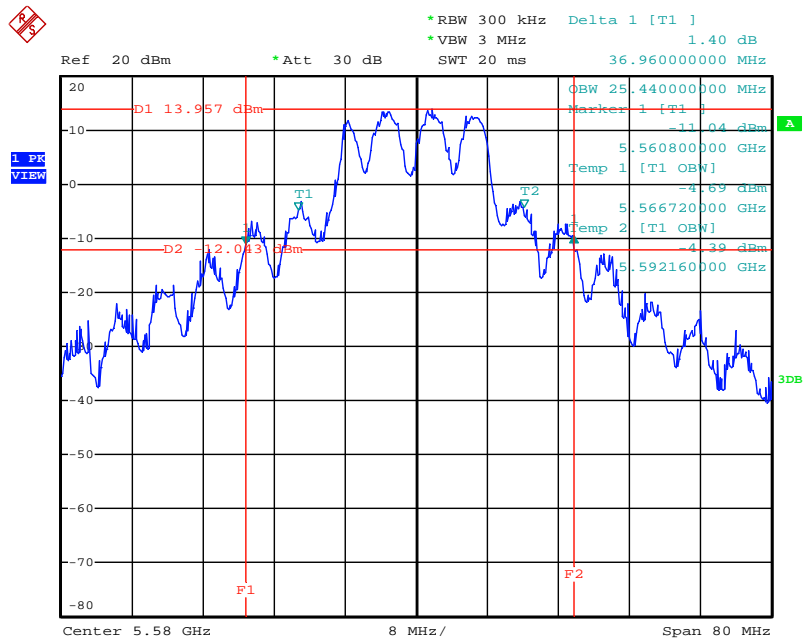

Date: 7.FEB.2013 07:22:23

26 dB Bandwidth Plot on Configuration IEEE 802.11a / Chain 1+ Chain 2 (2TX) / 5700 MHz

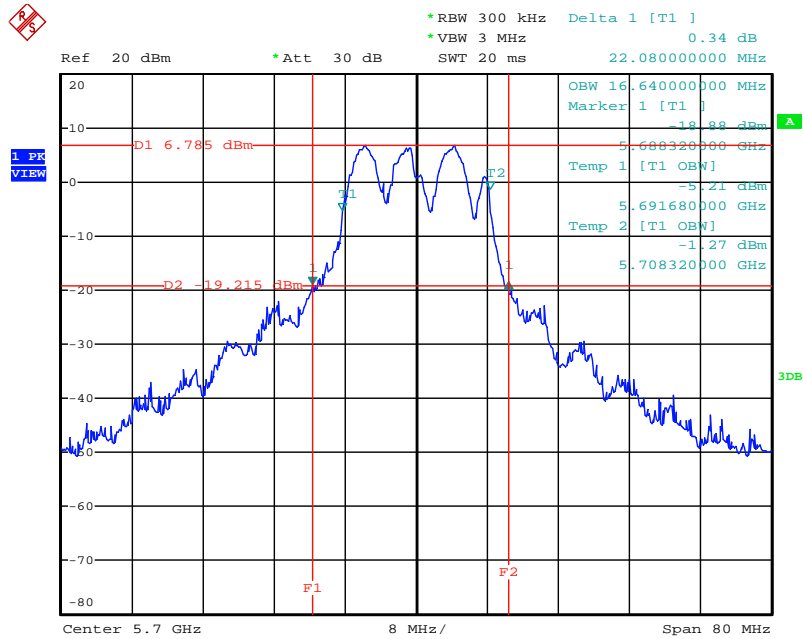

Date: 7.FEB.2013 07:22:58

4.3. Maximum Conducted Output Power Measurement

4.3.1. Limit

For the band 5.15~5.25 GHz, the maximum conducted output power over the frequency band of operation shall not exceed the lesser of 50 mW (17dBm) or $4 \text{ dBm} + 10\log B$, where B is the 26 dB emissions bandwidth in MHz. If transmitting antennas of directional gain greater than 6 dBi are used, both the maximum conducted output power and the peak power spectral density shall be reduced by the amount in dB that the directional gain of the antenna exceeds 6 dBi.

For the 5.25-5.35 GHz and 5.470-5.725 GHz bands, the maximum conducted output power over the frequency bands of operation shall not exceed the lesser of 250 mW (24dBm) or $11 \text{ dBm} + 10\log B$, where B is the 26-dB emission bandwidth in MHz. If transmitting antennas of directional gain greater than 6 dBi are used, both the maximum conducted output power and the peak power spectral density shall be reduced by the amount in dB that the directional gain of the antenna exceeds 6 dBi.

4.3.2. Measuring Instruments and Setting

The following table is the setting of the peak power meter.

Power Meter Parameter	Setting
Bandwidth	50MHz bandwidth is greater than the EUT emission bandwidth
Detector	AVERAGE

4.3.3. Test Procedures

1. The transmitter output (antenna port) was connected to the power meter.
2. Test was performed in accordance with KDB 789033 Guidelines for Compliance Testing of Unlicensed National Information Infrastructure (U-NII) Devices - Part 15, Subpart E, section (C) Maximum conducted output power =>(4) Method PM (Measurement using an RF average power meter) Multiple antenna systems was performed in accordance with KDB 662911 Emissions Testing of Transmitters with Multiple Outputs in the Same Band.
3. When measuring maximum conducted output power with multiple antenna systems, add every result of the values by mathematic formula.

4.3.4. Test Setup Layout

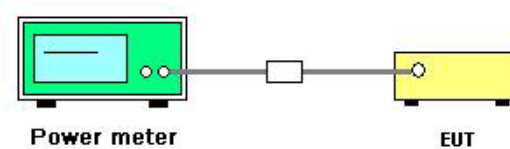

4.3.5. Test Deviation

There is no deviation with the original standard.

4.3.6. EUT Operation during Test

The EUT was programmed to be in continuously transmitting mode.

4.3.7. Test Result of Maximum Conducted Output Power

Temperature	25°C	Humidity	56%
Test Engineer	Benson Peng	Configurations	IEEE 802.11n
Test Date	Feb. 07, 2013		

Configuration IEEE 802.11n MCS0 20MHz / Chain 1+ Chain 2 (2TX)

Channel	Frequency	Conducted Power (dBm)		Total Conducted Output Power (dBm)	Max. Limit (dBm)	Result
		Chain 1	Chain 2			
36	5180 MHz	14.01	13.71	16.87	17.00	Complies
40	5200 MHz	13.69	13.93	16.82	17.00	Complies
48	5240 MHz	13.49	13.42	16.47	17.00	Complies
52	5260 MHz	20.96	20.86	23.92	24.00	Complies
60	5300 MHz	20.61	20.64	23.64	24.00	Complies
64	5320 MHz	18.15	18.52	21.35	24.00	Complies
100	5500 MHz	16.77	16.87	19.83	24.00	Complies
116	5580 MHz	21.08	20.36	23.75	24.00	Complies
140	5700 MHz	15.31	14.42	17.90	24.00	Complies

Configuration IEEE 802.11n MCS0 40MHz / Chain 1+ Chain 2 (2TX)

Channel	Frequency	Conducted Power (dBm)		Total Conducted Output Power (dBm)	Max. Limit (dBm)	Result
		Chain 1	Chain 2			
38	5190 MHz	13.31	13.44	16.39	17.00	Complies
46	5230 MHz	13.52	13.27	16.41	17.00	Complies
54	5270 MHz	20.93	20.35	23.66	24.00	Complies
62	5310 MHz	14.55	14.91	17.74	24.00	Complies
102	5510MHz	14.91	15.15	18.04	24.00	Complies
110	5550 MHz	21.08	20.58	23.85	24.00	Complies
134	5670 MHz	19.00	17.94	21.51	24.00	Complies

Temperature	25°C	Humidity	56%
Test Engineer	Benson Peng	Configurations	IEEE 802.11a
Test Date	Feb. 07, 2013		

Configuration IEEE 802.11a / Chain 1+ Chain 2 (2TX)

Channel	Frequency	Conducted Power (dBm)		Total Conducted Output Power (dBm)	Max. Limit (dBm)	Result
		Chain 1	Chain 2			
36	5180 MHz	13.35	13.68	16.53	17.00	Complies
40	5200 MHz	13.29	13.60	16.46	17.00	Complies
48	5240 MHz	13.78	13.76	16.78	17.00	Complies
52	5260 MHz	20.88	20.55	23.73	24.00	Complies
60	5300 MHz	20.59	20.71	23.66	24.00	Complies
64	5320 MHz	17.77	18.55	21.19	24.00	Complies
100	5500 MHz	16.93	17.15	20.05	24.00	Complies
116	5580 MHz	21.00	20.43	23.73	24.00	Complies
140	5700 MHz	16.39	15.22	18.85	24.00	Complies

4.4. Power Spectral Density Measurement

4.4.1. Limit

The power spectral density is defined as the highest level of power in dBm per MHz generated by the transmitter within the power envelope. The following table is power spectral density limits and decrease power density limit rule refer to section 4.3.1.

Frequency Range	Power Spectral Density limit (dBm/MHz)
5.15~5.25 GHz	4
5.25-5.35 GHz	11
5470-5725	11

4.4.2. Measuring Instruments and Setting

Please refer to section 5 of equipments list in this report. The following table is the setting of the spectrum analyzer.

Spectrum Parameter	Setting
Attenuation	Auto
Span Frequency	Encompass the entire emissions bandwidth (EBW) of the signal
RB	1000 kHz
VB	3000 kHz
Detector	RMS
Trace	AVERAGE
Sweep Time	Auto
Trace Average	100 times

4.4.3. Test Procedures

1. The transmitter output (antenna port) was connected RF switch to the spectrum analyzer.
2. Test was performed in accordance with KDB 789033 Guidelines for Compliance Testing of Unlicensed National Information Infrastructure (U-NII) Devices - Part 15, Subpart E, section (C) Maximum conducted output power => (d) Method SA-2 (trace averaging across on and off times of the EUT transmissions, followed by duty cycle correction).
3. Multiple antenna systems was performed in accordance with KDB 662911 in-Band Power Spectral Density (PSD) Measurements (1) Measure and sum the spectra across the outputs.
4. When measuring first spectral bin of output 1 is summed with that in the first spectral bin of output 2 and that from the first spectral bin of output 3 and so on up to the Nth output to obtain the value for the first frequency bin of the summed spectrum. The summed spectrum value for each of the other frequency bins is computed in the same way.

4.4.4. Test Setup Layout

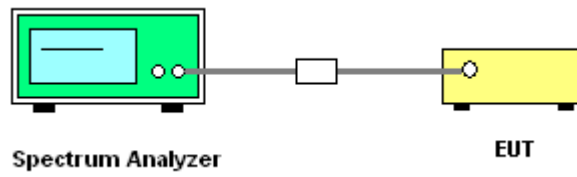

4.4.5. Test Deviation

There is no deviation with the original standard.

4.4.6. EUT Operation during Test

The EUT was programmed to be in continuously transmitting mode.

4.4.7. Test Result of Power Spectral Density

Temperature	25°C	Humidity	56%
Test Engineer	Benson Peng	Configurations	IEEE 802.11n
Test Date	Feb. 07, 2013		

Configuration IEEE 802.11n MCS0 20MHz / Chain 1+ Chain 2 (2TX)

Channel	Frequency	Power Density (dBm/MHz)	Max. Limit (dBm/MHz)	Result
36	5180 MHz	2.57	4.00	Complies
40	5200 MHz	2.62	4.00	Complies
48	5240 MHz	2.19	4.00	Complies
52	5260 MHz	9.64	11.00	Complies
60	5300 MHz	9.33	11.00	Complies
64	5320 MHz	7.02	11.00	Complies
100	5500 MHz	5.82	11.00	Complies
116	5580 MHz	9.81	11.00	Complies
140	5700 MHz	3.15	11.00	Complies

Note: Directional gain = $G_{ant} + 10 \cdot \log(N_{ant}/N_{ss}) = 5.01 \text{ dBi} < 6 \text{ dBi}$, so Limit = 4dBm/MHz.

Directional gain = $G_{ant} + 10 \cdot \log(N_{ant}/N_{ss}) = 5.01 \text{ dBi} < 6 \text{ dBi}$, so Limit = 11dBm/MHz.

Configuration IEEE 802.11n MCS0 40MHz / Chain 1+ Chain 2 (2TX)

Channel	Frequency	Power Density (dBm/MHz)	Max. Limit (dBm/MHz)	Result
38	5190 MHz	-0.89	4.00	Complies
46	5230 MHz	-0.74	4.00	Complies
54	5270 MHz	6.51	11.00	Complies
62	5310 MHz	0.22	11.00	Complies
102	5510MHz	0.86	11.00	Complies
110	5550 MHz	6.66	11.00	Complies
134	5670 MHz	3.92	11.00	Complies

Note: Directional gain = $G_{ant} + 10 \cdot \log(N_{ant}/N_{ss}) = 5.01 \text{ dBi} < 6 \text{ dBi}$, so Limit = 4dBm/MHz.

Directional gain = $G_{ant} + 10 \cdot \log(N_{ant}/N_{ss}) = 5.01 \text{ dBi} < 6 \text{ dBi}$, so Limit = 11dBm/MHz.

Temperature	25°C	Humidity	56%
Test Engineer	Benson Peng	Configurations	IEEE 802.11a
Test Date	Feb. 07, 2013		

Configuration IEEE 802.11a / Chain 1+ Chain 2 (2TX)

Channel	Frequency	Power Density (dBm/MHz)	Max. Limit (dBm/MHz)	Result
36	5180 MHz	3.38	4.00	Complies
40	5200 MHz	2.31	4.00	Complies
48	5240 MHz	2.72	4.00	Complies
52	5260 MHz	10.47	11.00	Complies
60	5300 MHz	9.82	11.00	Complies
64	5320 MHz	7.00	11.00	Complies
100	5500 MHz	6.39	11.00	Complies
116	5580 MHz	10.60	11.00	Complies
140	5700 MHz	5.17	11.00	Complies

Note: Directional gain = $G_{ant} + 10 \cdot \log(N_{ant}/N_{ss}) = 5.01 \text{ dBi} < 6 \text{ dBi}$, so Limit = 4dBm/MHz.

Directional gain = $G_{ant} + 10 \cdot \log(N_{ant}/N_{ss}) = 5.01 \text{ dBi} < 6 \text{ dBi}$, so Limit = 11dBm/MHz.

Note: All the test values were listed in the report.

For plots, only the channel with maximum results was shown.

Power Density Plot on Configuration IEEE 802.11n MCS0 20MHz / Chain 1+ Chain 2 (2TX) / 5200 MHz

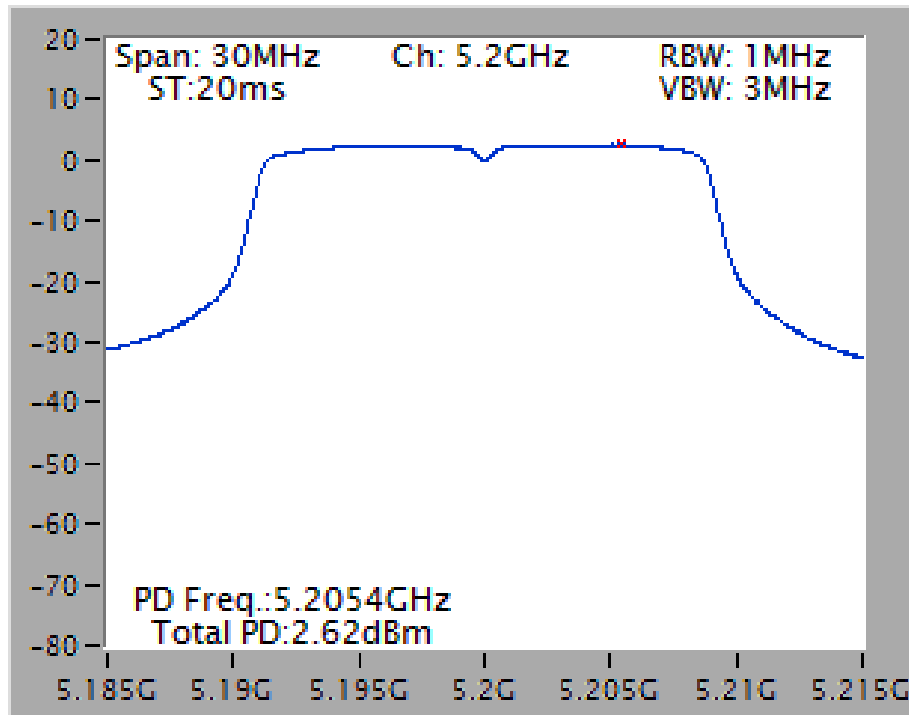

Power Density Plot on Configuration IEEE 802.11n MCS0 20MHz / Chain 1+ Chain 2 (2TX) / 5260 MHz

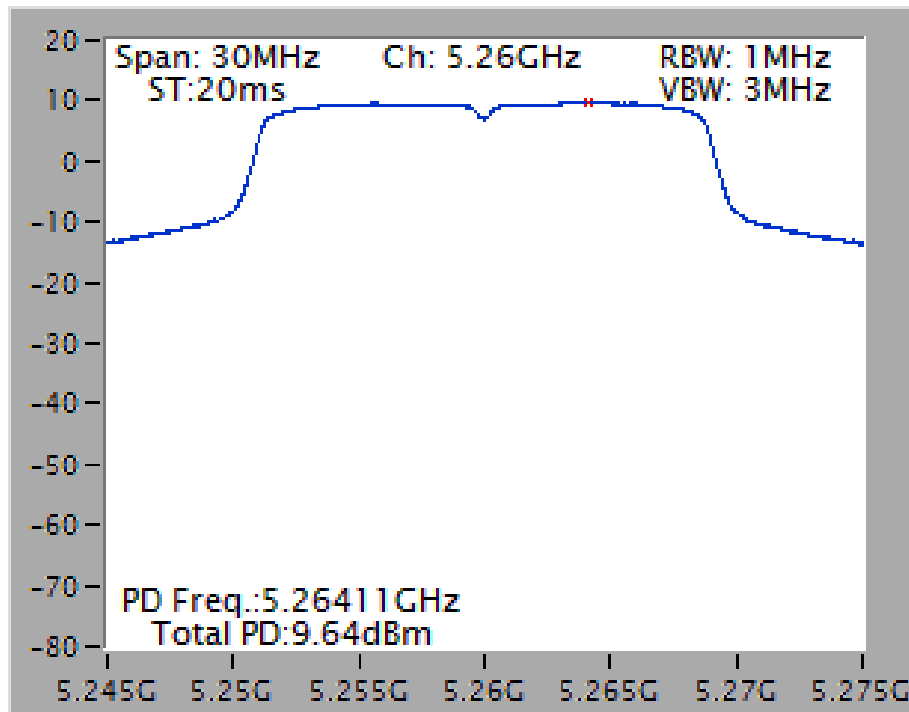

Power Density Plot on Configuration IEEE 802.11n MCS0 20MHz / Chain 1+ Chain 2 (2TX) / 5580 MHz

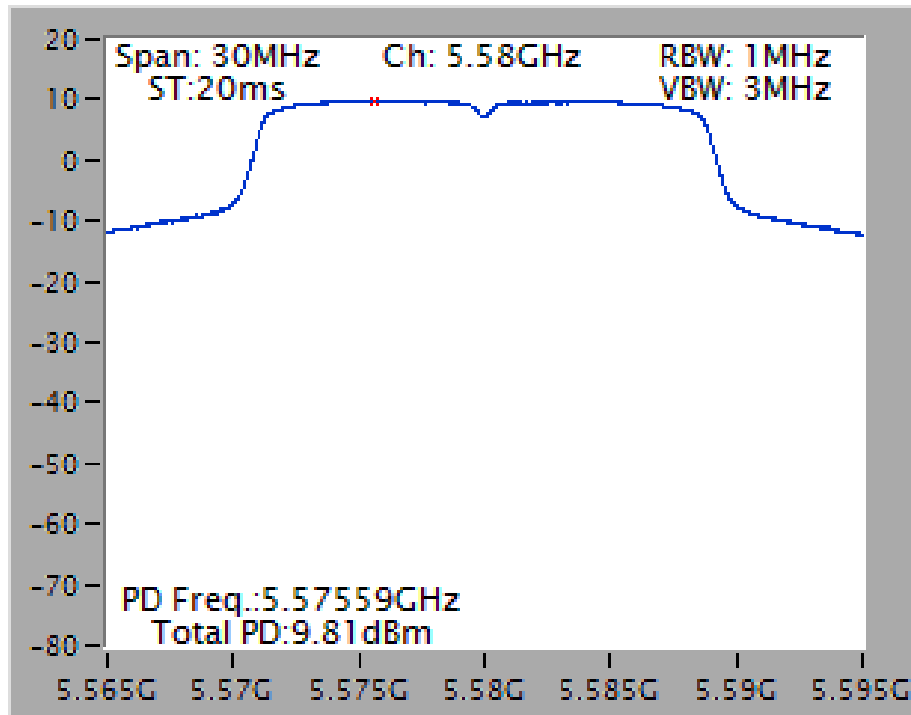

Power Density Plot on Configuration IEEE 802.11n MCS0 40MHz / Chain 1+ Chain 2 (2TX) / 5230 MHz

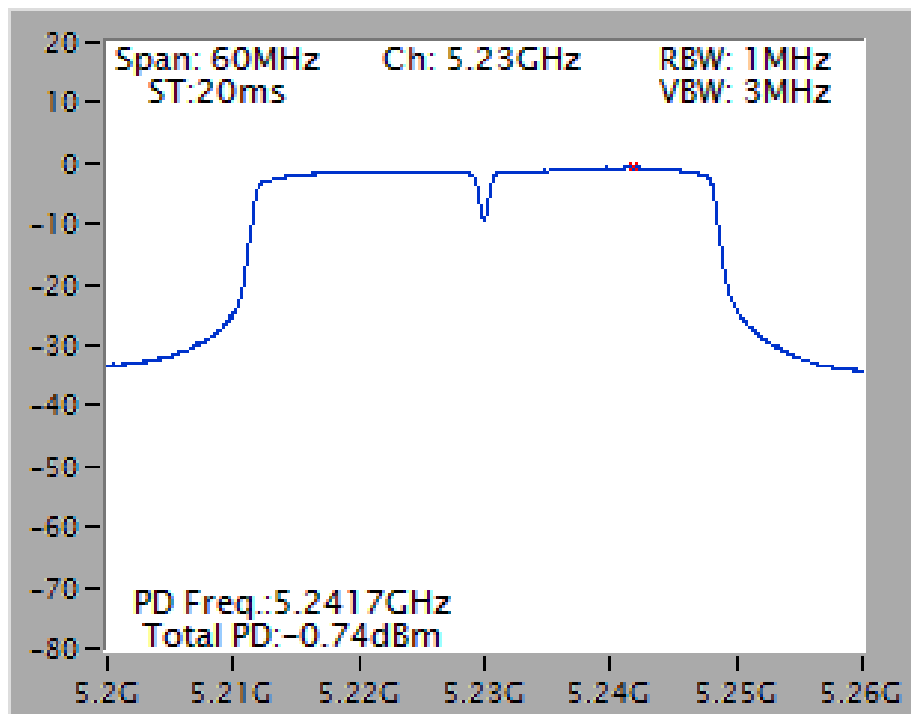

Power Density Plot on Configuration IEEE 802.11n MCS0 40MHz / Chain 1+ Chain 2 (2TX) / 5270 MHz

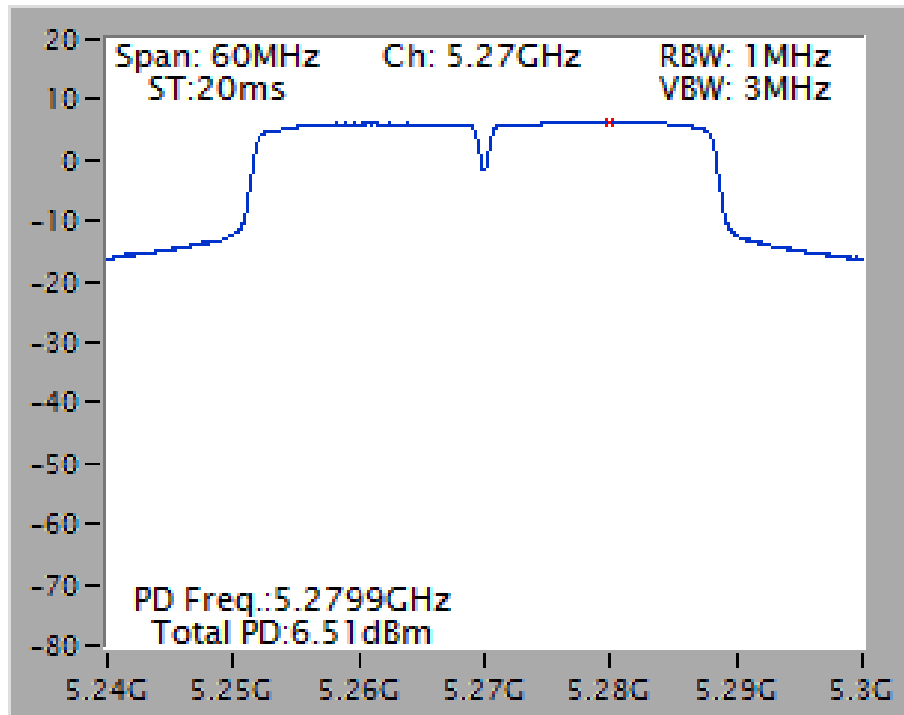

Power Density Plot on Configuration IEEE 802.11n MCS0 40MHz / Chain 1+ Chain 2 (2TX) / 5550 MHz

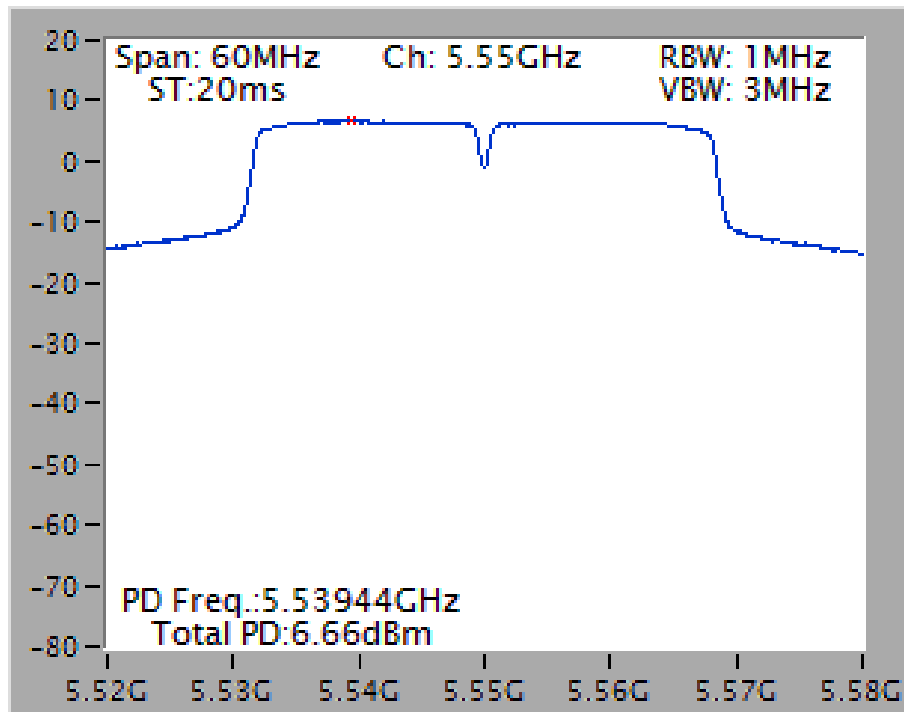

Power Density Plot on Configuration IEEE 802.11a / Chain 1+ Chain 2 (2TX) / 5180 MHz

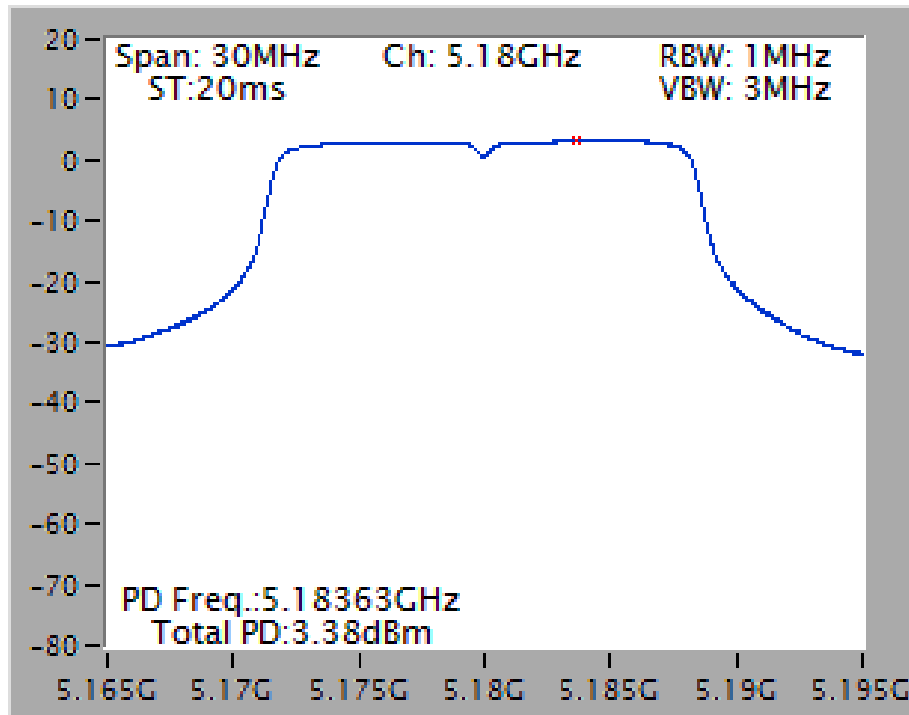

Power Density Plot on Configuration IEEE 802.11a / Chain 1+ Chain 2 (2TX) / 5260 MHz

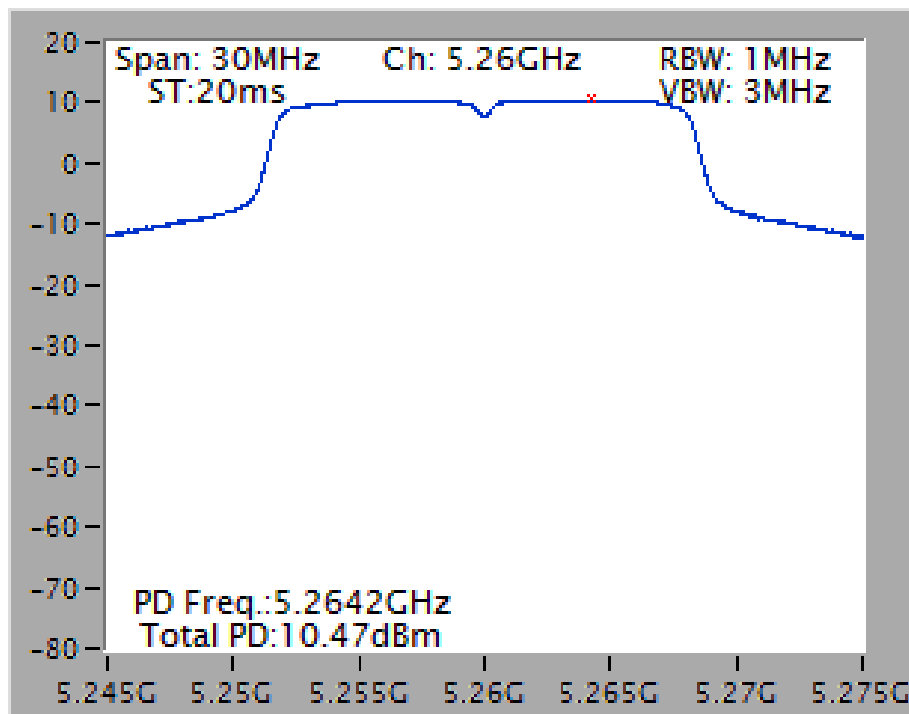

Power Density Plot on Configuration IEEE 802.11a / Chain 1+ Chain 2 (2TX) / 5580 MHz

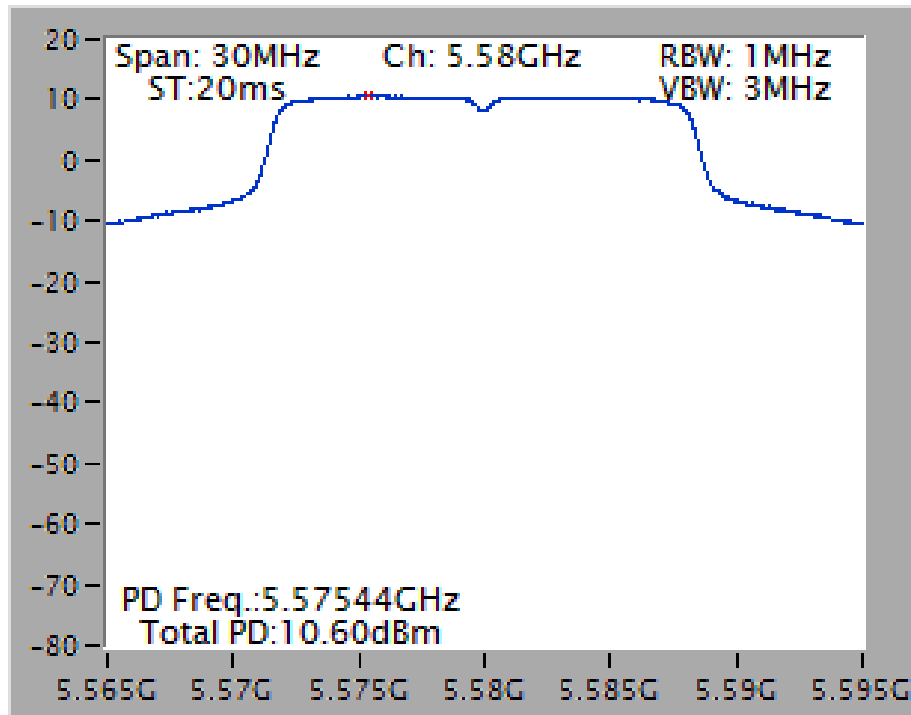

4.5. Peak Excursion Measurement

4.5.1. Limit

The ratio of the peak excursion of the modulation envelope (measured using a peak hold function) to the maximum conducted output power (measured as specified above) shall not exceed 13 dB across any 1 MHz bandwidth or the emissions bandwidth whichever is less.

4.5.2. Measuring Instruments and Setting

Please refer to section 5 of equipments list in this report. The following table is the setting of the spectrum analyzer.

Spectrum Parameter	Setting
Attenuation	Auto
Span Frequency	Encompass the entire emissions bandwidth (EBW) of the signal
RB	1MHz (Peak Trace) / 1MHz (Average Trace)
VB	3MHz (Peak Trace) / 3MHz (Average Trace)
Detector	Peak (Peak Trace) / RMS (Average Trace)
Trace	Peak : Trace :Max hold/Average: Trace Average Sweep Count 100
Sweep Time	AUTO

4.5.3. Test Procedures

1. The test procedure is the same as section 4.6.3.
2. Trace A, Set RBW =1MHz, VBW = 3MHz, Span >26dB bandwidth, Max. hold.
3. Delta Mark trace A Maximum frequency and trace B same frequency.
4. Repeat the above procedure until measurements for all frequencies were complete.

4.5.4. Test Setup Layout

This test setup layout is the same as that shown in section 4.6.4.

4.5.5. Test Deviation

There is no deviation with the original standard.

4.5.6. EUT Operation during Test

The EUT was programmed to be in continuously transmitting mode.

4.5.7. Test Result of Peak Excursion

Temperature	25°C	Humidity	56%
Test Engineer	Benson Peng	Configurations	IEEE 802.11n

Configuration IEEE 802.11n MCS0 20MHz / Chain 1+ Chain 2 (2TX)

Channel	Frequency	Peak Excursion (dB)	Max. Limit (dB)	Result
36	5180 MHz	8.79	13	Complies
52	5260 MHz	9.44	13	Complies
116	5580 MHz	8.87	13	Complies

Configuration IEEE 802.11n MCS0 40MHz / Chain 1+ Chain 2 (2TX)

Channel	Frequency	Peak Excursion (dB)	Max. Limit (dB)	Result
46	5230 MHz	9.51	13	Complies
54	5270 MHz	9.35	13	Complies
110	5550 MHz	10.81	13	Complies

Temperature	25°C	Humidity	56%
Test Engineer	Benson Peng	Configurations	IEEE 802.11a

Configuration IEEE 802.11a / Chain 1+ Chain 2 (2TX)

Channel	Frequency	Peak Excursion (dB)	Max. Limit (dB)	Result
48	5240 MHz	8.81	13	Complies
52	5260 MHz	9.02	13	Complies
116	5580 MHz	9.65	13	Complies

Peak Excursion Plot on Configuration IEEE 802.11n MCS0 20MHz / Chain 1+ Chain 2 (2TX) / 5180 MHz

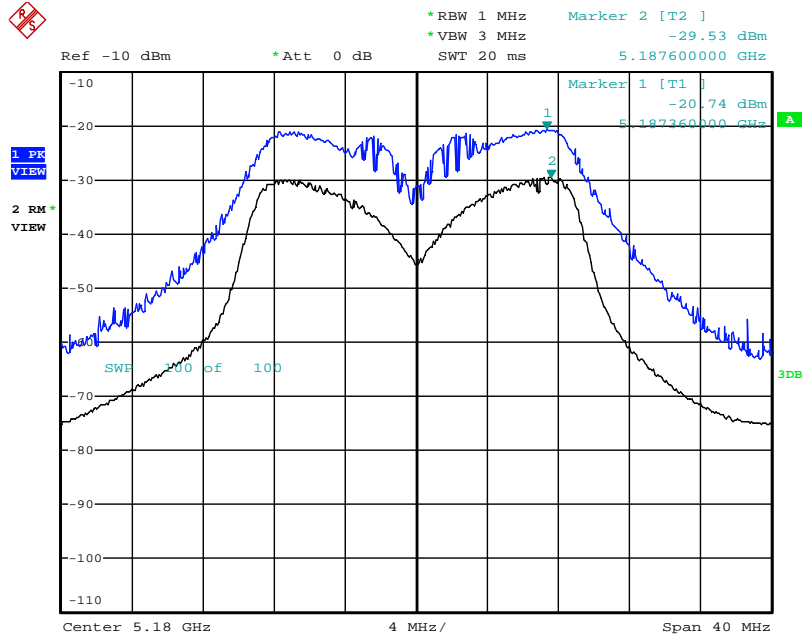

Date: 7.FEB.2013 07:52:54

Peak Excursion Plot on Configuration IEEE 802.11n MCS0 20MHz / Chain 1+ Chain 2 (2TX) / 5260 MHz

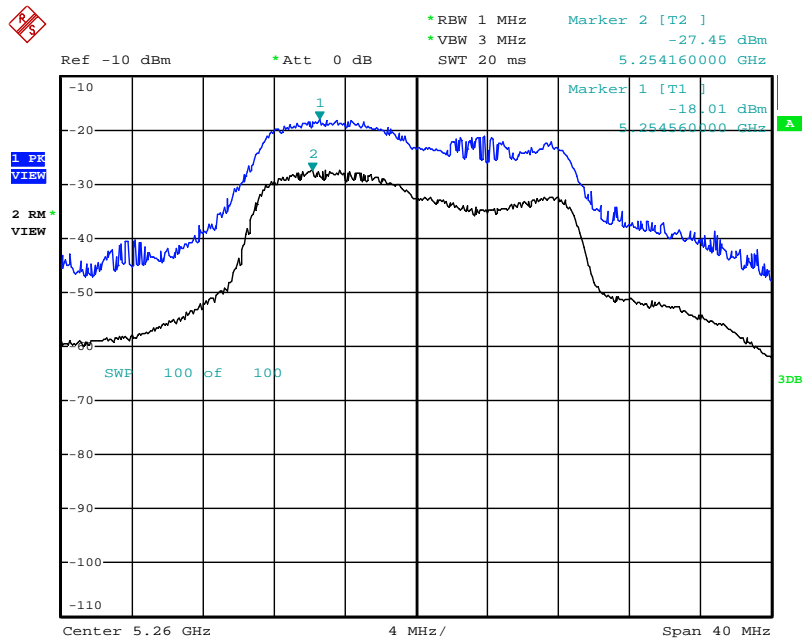

Date: 7.FEB.2013 07:54:34

Peak Excursion Plot on Configuration IEEE 802.11n MCS0 20MHz / Chain 1+ Chain 2 (2TX) / 5580 MHz

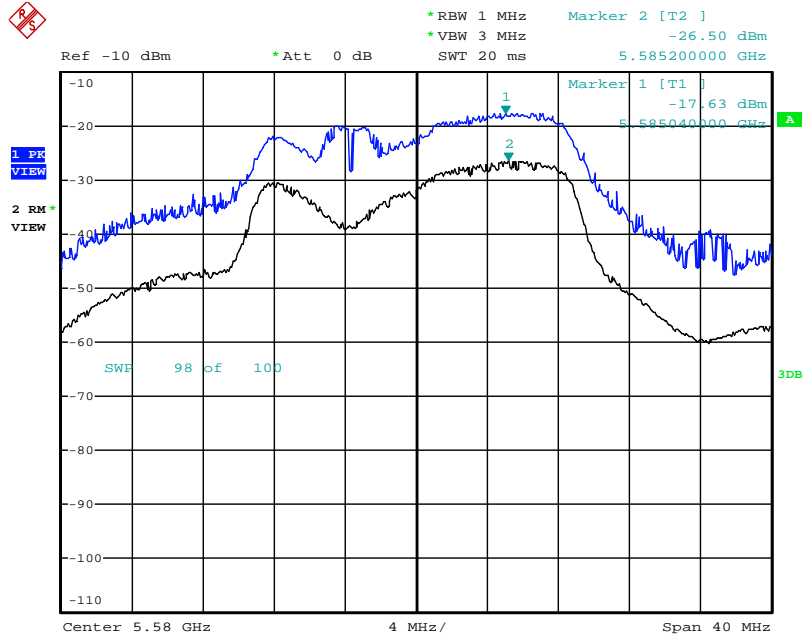

Date: 7.FEB.2013 07:55:21

Peak Excursion Plot on Configuration IEEE 802.11n MCS0 40MHz / Chain 1+ Chain 2 (2TX) / 5230 MHz

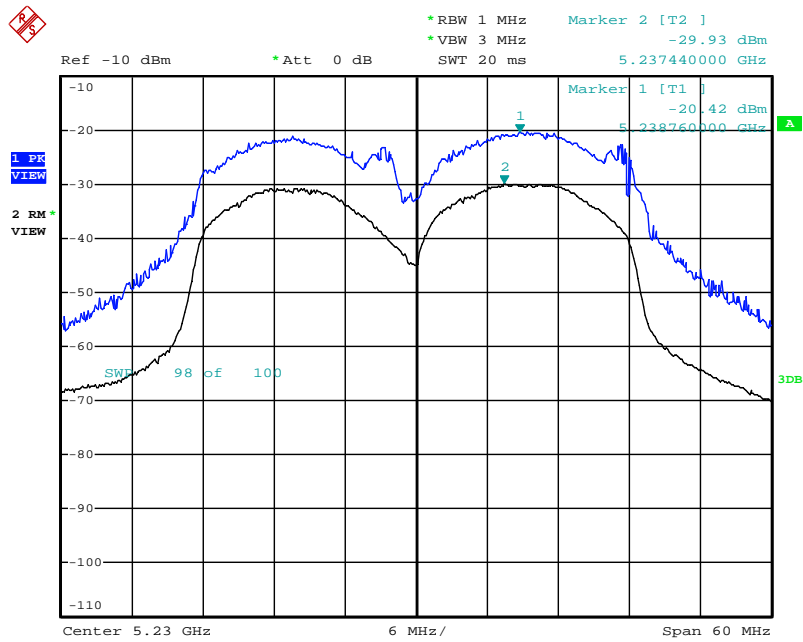

Date: 7.FEB.2013 07:56:32

Peak Excursion Plot on Configuration IEEE 802.11n MCS0 40MHz / Chain 1+ Chain 2 (2TX) / 5270 MHz

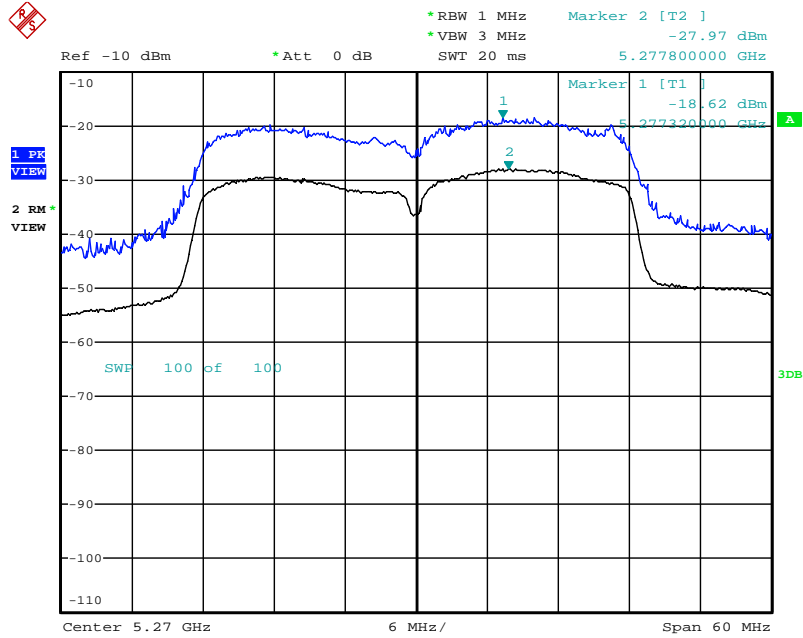

Date: 7.FEB.2013 07:58:01

Peak Excursion Plot on Configuration IEEE 802.11n MCS0 40MHz / Chain 1+ Chain 2 (2TX) / 5550 MHz

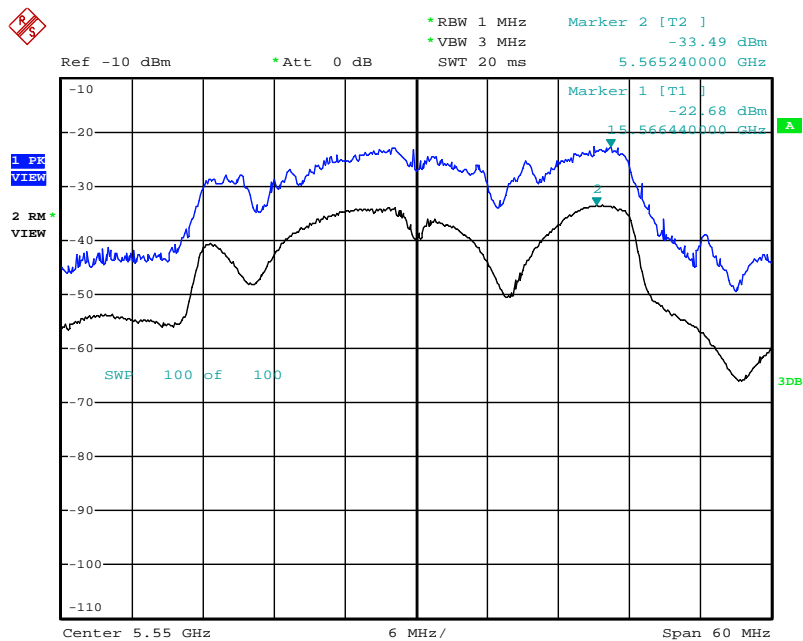

Date: 7.FEB.2013 07:58:46

Peak Excursion Plot on Configuration IEEE 802.11a / Chain 1+ Chain 2 (2TX) / 5240 MHz

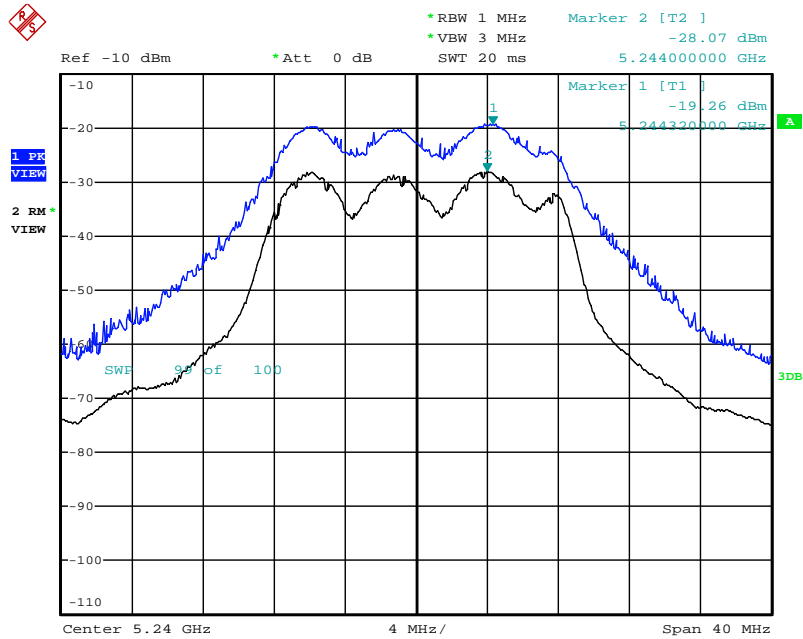

Date: 7.FEB.2013 07:41:48

Peak Excursion Plot on Configuration IEEE 802.11a / Chain 1+ Chain 2 (2TX) / 5260 MHz

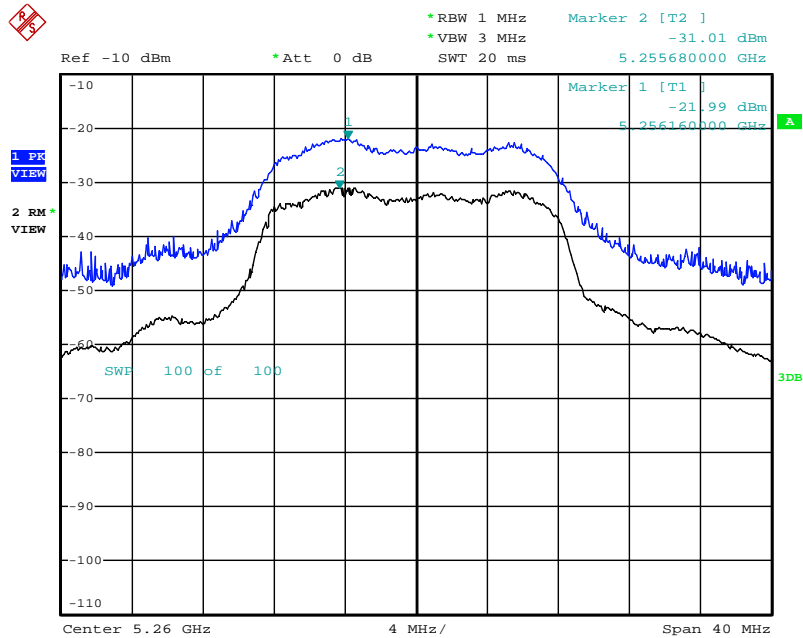

Date: 7.FEB.2013 07:49:52

Peak Excursion Plot on Configuration IEEE 802.11a / Chain 1+ Chain 2 (2TX) / 5580 MHz

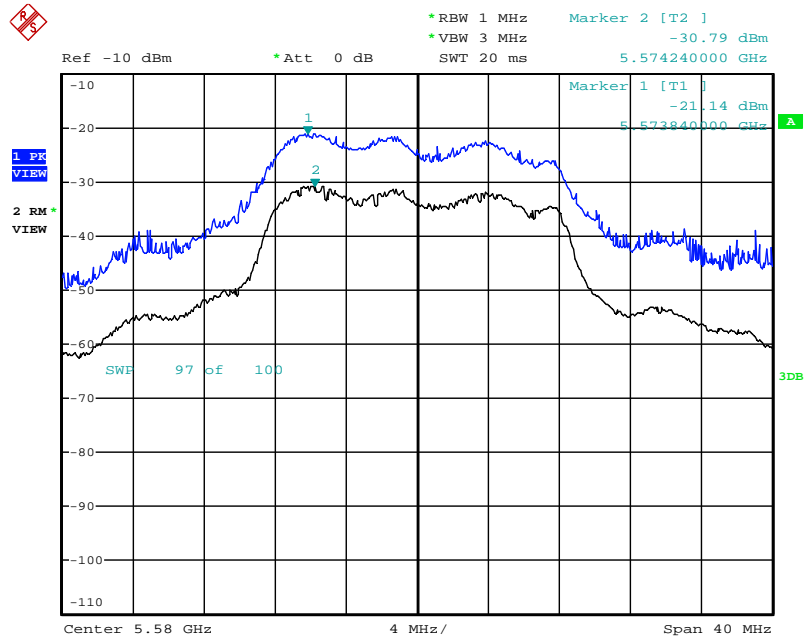

Date: 7.FEB.2013 07:50:38

4.6. Radiated Emissions Measurement

4.6.1. Limit

For transmitters operating in the 5.15-5.35 GHz band: all emissions outside of the 5.15-5.35 GHz band shall not exceed an EIRP of -27 dBm/MHz (68.3dBuV/m at 3m). For transmitters operating in the 5.470-5.725 GHz band: all emissions outside of the 5.470-5.725 GHz band shall not exceed an EIRP of -27 dBm/MHz (68.3dBuV/m at 3m). For frequencies 10 MHz or greater above or below the band edge, emissions shall not exceed an EIRP of -27 dBm/MHz (68.3dBuV/m at 3m). In addition, In case the emission fall within the restricted band specified on 15.205(a), then the 15.209(a) limit in the table below has to be followed.

Frequencies (MHz)	Field Strength (micровolts/meter)	Measurement Distance (meters)
0.009~0.490	2400/F(KHz)	300
0.490~1.705	24000/F(KHz)	30
1.705~30.0	30	30
30~88	100	3
88~216	150	3
216~960	200	3
Above 960	500	3

4.6.2. Measuring Instruments and Setting

Please refer to section 5 of equipments list in this report. The following table is the setting of spectrum analyzer and receiver.

Spectrum Parameter	Setting
Attenuation	Auto
Start Frequency	1000 MHz
Stop Frequency	40 GHz
RB / VB (Emission in restricted band)	1MHz / 3MHz for Peak, 1 MHz / 10Hz for Average
RB / VB (Emission in non-restricted band)	1MHz / 3MHz for peak

Receiver Parameter	Setting
Attenuation	Auto
Start ~ Stop Frequency	9kHz~150kHz / RB 200Hz for QP
Start ~ Stop Frequency	150kHz~30MHz / RB 9kHz for QP
Start ~ Stop Frequency	30MHz~1000MHz / RB 120kHz for QP

4.6.3. Test Procedures

1. Configure the EUT according to ANSI C63.10. The EUT was placed on the top of the turntable 0.8 meter above ground. The phase center of the receiving antenna mounted on the top of a height-variable antenna tower was placed 3 meters far away from the turntable.
2. Power on the EUT and all the supporting units. The turntable was rotated by 360 degrees to determine the position of the highest radiation.
3. The height of the broadband receiving antenna was varied between one meter and four meters above ground to find the maximum emissions field strength of both horizontal and vertical polarization.
4. For each suspected emissions, the antenna tower was scan (from 1 M to 4 M) and then the turntable was rotated (from 0 degree to 360 degrees) to find the maximum reading.
5. Set the test-receiver system to Peak or CISPR quasi-peak Detect Function with specified bandwidth under Maximum Hold Mode.
6. For emissions above 1GHz, use 1MHz VBW and RBW for peak reading. Then 1MHz RBW and 10Hz VBW for average reading in spectrum analyzer.
7. When the radiated emissions limits are expressed in terms of the average value of the emissions, and pulsed operation is employed, the measurement field strength shall be determined by averaging over one complete pulse train, including blanking intervals, as long as the pulse train does not exceed 0.1 seconds. As an alternative (provided the transmitter operates for longer than 0.1 seconds) or in cases where the pulse train exceeds 0.1 seconds, the measured field strength shall be determined from the average absolute voltage during a 0.1 second interval during which the field strength is at its maximum value.
8. If the emissions level of the EUT in peak mode was 3 dB lower than the average limit specified, then testing will be stopped and peak values of EUT will be reported, otherwise, the emissions which do not have 3 dB margin will be repeated one by one using the quasi-peak method for below 1GHz.
9. For testing above 1GHz, the emissions level of the EUT in peak mode was lower than average limit (that means the emissions level in peak mode also complies with the limit in average mode), then testing will be stopped and peak values of EUT will be reported, otherwise, the emissions will be measured in average mode again and reported.
10. In case the emission is lower than 30MHz, loop antenna has to be used for measurement and the recorded data should be QP measured by receiver. High – Low scan is not required in this case.

4.6.4. Test Setup Layout

For radiated emissions below 1GHz

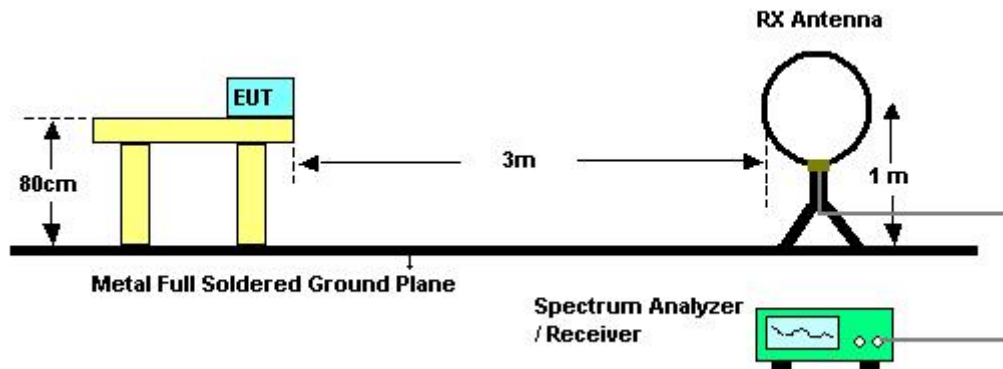

For radiated emissions above 1GHz

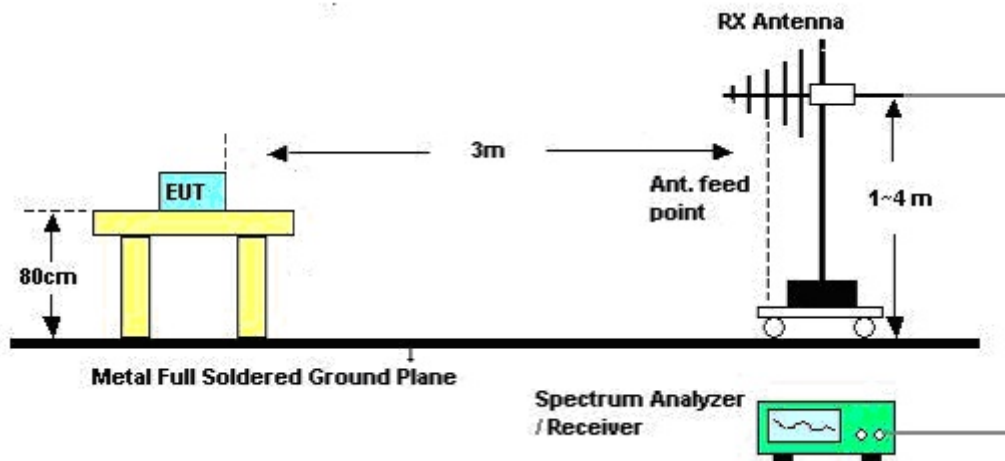

4.6.5. Test Deviation

There is no deviation with the original standard.

4.6.6. EUT Operation during Test

The EUT was programmed to be in continuously transmitting mode.

4.6.7. Results of Radiated Emissions (9kHz~30MHz)

Temperature	26°C	Humidity	60%
Test Engineer	Jim Huang	Configurations	Normal Link
Test Date	Feb. 04, 2013		

Freq. (MHz)	Level (dBuV)	Over Limit (dB)	Limit Line (dBuV)	Remark
-	-	-	-	See Note

Note:

The amplitude of spurious emissions that are attenuated by more than 20dB below the permissible value has no need to be reported.

Distance extrapolation factor = $40 \log(\text{specific distance} / \text{test distance})$ (dB);

Limit line = specific limits (dBuV) + distance extrapolation factor.

4.6.8. Results of Radiated Emissions (30MHz~1GHz)

Temperature	26°C	Humidity	60%
Test Engineer	Jim Huang	Configurations	Normal Link

Horizontal

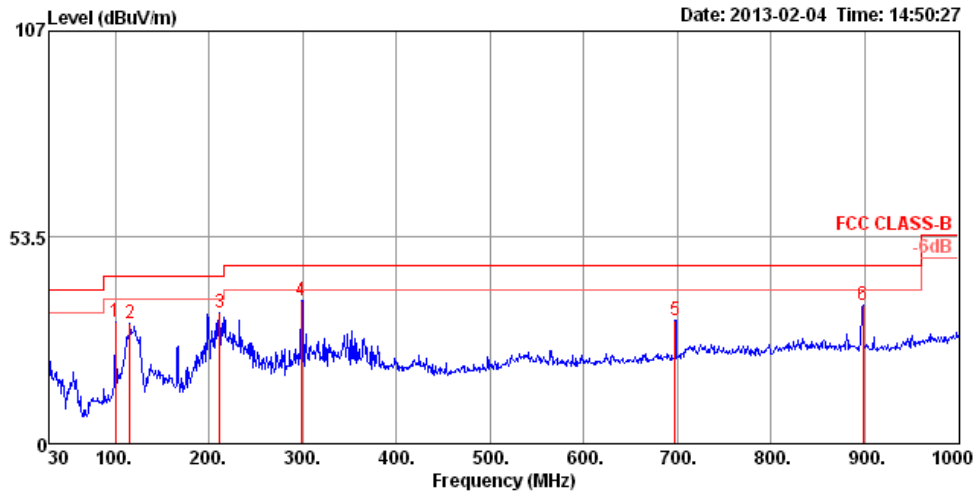

	Freq	Level	Limit Line	Over Limit	Read Level	Cable Loss	Antenna Factor	Preamp Factor	A/Pos	T/Pos	Pol/Phase	Remark
	MHz	dBuV/m	dBuV/m	dB	dBuV	dB	dB/m	dB	cm	deg		
1	99.84	31.58	43.50	-11.92	51.70	1.18	10.31	31.61	300	345	HORIZONTAL	Peak
2	115.36	31.02	43.50	-12.48	49.81	1.27	11.49	31.55	300	360	HORIZONTAL	Peak
3	211.39	33.77	43.50	-9.73	54.97	1.78	8.44	31.42	125	326	HORIZONTAL	Peak
4 pp	298.69	37.17	46.00	-8.83	53.50	2.12	12.98	31.43	100	175	HORIZONTAL	Peak
5	697.36	32.16	46.00	-13.84	41.18	3.40	18.89	31.31	150	66	HORIZONTAL	Peak
6	898.15	35.77	46.00	-10.23	42.37	3.97	20.63	31.20	100	262	HORIZONTAL	Peak

Vertical

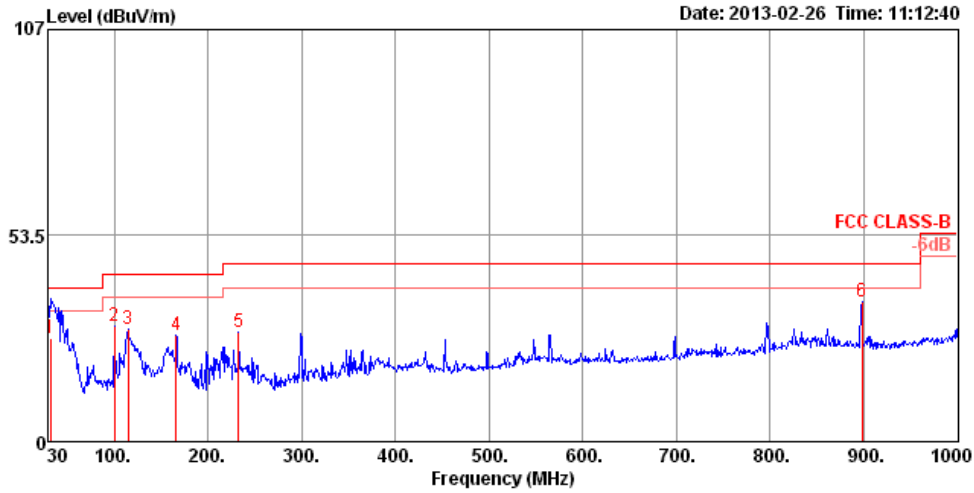

	Freq	Level	Limit Line	Over Limit	Read Level	Cable Loss	Antenna Factor	Preamp Factor	A/Pos	T/Pos	Pol/Phase	Remark
	MHz	dBuV/m	dBuV/m	dB	dBuV	dB	dB/m	dB	cm	deg		
1	qp	31.94	27.03	40.00	-12.97	41.30	0.66	16.91	31.84	100	65 VERTICAL	QP
2		99.84	30.12	43.50	-13.38	50.24	1.18	10.31	31.61	100	12 VERTICAL	Peak
3		114.39	29.37	43.50	-14.13	48.18	1.27	11.47	31.55	100	190 VERTICAL	Peak
4		165.80	27.78	43.50	-15.72	48.38	1.56	9.38	31.54	100	1 VERTICAL	Peak
5		232.73	28.40	46.00	-17.60	47.99	1.84	10.02	31.45	100	202 VERTICAL	Peak
6	pp	898.15	36.39	46.00	-9.61	42.99	3.97	20.63	31.20	125	358 VERTICAL	Peak

Note:

The amplitude of spurious emissions that are attenuated by more than 20dB below the permissible value has no need to be reported.

Emission level (dBuV/m) = 20 log Emission level (uV/m).

Corrected Reading: Antenna Factor + Cable Loss + Read Level - Preamp Factor = Level.

4.6.9. Results for Radiated Emissions (1GHz~40GHz)

Temperature	25.6°C	Humidity	56%
Test Engineer	Andre Tak	Configurations	IEEE 802.11n MCS0 20MHz Ch 36 / Chain 1+ Chain 2 (2TX)
Test Date	Jan. 31, 2013		

Horizontal

	Freq	Level	Limit Line	Over Limit	Read Level	Cable Loss	Antenna Factor	Preamp Factor	Remark	A/Pos	T/Pos	PoI/Phase
	MHz	dBuV/m	dBuV/m	dB	dBuV	dB	dB/m	dB		cm	deg	
1	4959.94	46.10	74.00	-27.90	44.41	3.37	33.33	35.01	Peak	100	284	HORIZONTAL
2	4959.95	38.32	54.00	-15.68	36.63	3.37	33.33	35.01	Average	100	284	HORIZONTAL
3	15533.80	49.92	74.00	-24.08	41.41	6.13	37.67	35.29	Peak	100	313	HORIZONTAL
4	15536.92	37.28	54.00	-16.72	28.77	6.13	37.67	35.29	Average	100	313	HORIZONTAL

Vertical

	Freq	Level	Limit Line	Over Limit	Read Level	Cable Loss	Antenna Factor	Preamp Factor	Remark	A/Pos	T/Pos	PoI/Phase
	MHz	dBuV/m	dBuV/m	dB	dBuV	dB	dB/m	dB		cm	deg	
1	4959.98	44.48	54.00	-9.52	42.79	3.37	33.33	35.01	Average	100	161	VERTICAL
2	4959.99	49.74	74.00	-24.26	48.05	3.37	33.33	35.01	Peak	100	161	VERTICAL
3	15539.80	37.41	54.00	-16.59	28.90	6.13	37.69	35.31	Average	100	229	VERTICAL
4	15546.24	50.71	74.00	-23.29	42.20	6.13	37.69	35.31	Peak	100	229	VERTICAL



Temperature	25.6°C	Humidity	56%
Test Engineer	Andre Tak	Configurations	IEEE 802.11n MCS0 20MHz Ch 40 / Chain 1+ Chain 2 (2TX)
Test Date	Jan. 31, 2013		

Horizontal

	Freq	Level	Limit	Over	Read	CableAntenna	Preamp	Remark	A/Pos	T/Pos	Pol/Phase
	MHz	dBuV/m	dBuV/m	dB	dBuV	dB	dB/m	dB	cm	deg	
1	4959.98	49.01	74.00	-24.99	47.32	3.37	33.33	35.01	Peak	100	134 HORIZONTAL
2	4960.02	40.76	54.00	-13.24	39.07	3.37	33.33	35.01	Average	100	134 HORIZONTAL
3	15599.58	50.60	74.00	-23.40	42.21	6.13	37.60	35.34	Peak	100	257 HORIZONTAL
4	15599.63	37.77	54.00	-16.23	29.38	6.13	37.60	35.34	Average	100	257 HORIZONTAL

Vertical

	Freq	Level	Limit	Over	Read	CableAntenna	Preamp	Remark	A/Pos	T/Pos	Pol/Phase
	MHz	dBuV/m	dBuV/m	dB	dBuV	dB	dB/m	dB	cm	deg	
1	4959.96	48.38	54.00	-5.62	46.69	3.37	33.33	35.01	Average	113	178 VERTICAL
2	4960.06	55.82	74.00	-18.18	54.13	3.37	33.33	35.01	Peak	113	178 VERTICAL
3	15599.82	38.74	54.00	-15.26	30.35	6.13	37.60	35.34	Average	100	158 VERTICAL
4	15600.16	51.22	74.00	-22.78	42.83	6.13	37.60	35.34	Peak	100	158 VERTICAL



Temperature	25.6°C	Humidity	56%
Test Engineer	Andre Tak	Configurations	IEEE 802.11n MCS0 20MHz Ch 48 / Chain 1+ Chain 2 (2TX)
Test Date	Jan. 31, 2013		

Horizontal

	Freq	Level	Limit	Over	Read	Cable	Antenna	Preamp	Remark	A/Pos	T/Pos	Pol/Phase
	MHz	dBuV/m	dBuV/m	dB	dBuV	dB	dB/m	dB		cm	deg	
1	4959.93	41.99	54.00	-12.01	40.30	3.37	33.33	35.01	Average	103	133	HORIZONTAL
2	4959.98	49.92	74.00	-24.08	48.23	3.37	33.33	35.01	Peak	103	133	HORIZONTAL
3	15719.79	49.76	74.00	-24.24	41.53	6.14	37.48	35.39	Peak	100	196	HORIZONTAL
4	15720.05	36.84	54.00	-17.16	28.61	6.14	37.48	35.39	Average	100	196	HORIZONTAL

Vertical

	Freq	Level	Limit	Over	Read	Cable	Antenna	Preamp	Remark	A/Pos	T/Pos	Pol/Phase
	MHz	dBuV/m	dBuV/m	dB	dBuV	dB	dB/m	dB		cm	deg	
1	4959.90	55.92	74.00	-18.08	54.23	3.37	33.33	35.01	Peak	101	177	VERTICAL
2	4959.97	48.83	54.00	-5.17	47.14	3.37	33.33	35.01	Average	101	177	VERTICAL
3	15719.55	51.29	74.00	-22.71	43.06	6.14	37.48	35.39	Peak	100	292	VERTICAL
4	15719.67	37.61	54.00	-16.39	29.38	6.14	37.48	35.39	Average	100	292	VERTICAL



Temperature	25.6°C	Humidity	56%
Test Engineer	Andre Tak	Configurations	IEEE 802.11n MCS0 20MHz Ch 52 / Chain 1+ Chain 2 (2TX)
Test Date	Jan. 31, 2013		

Horizontal

	Freq	Level	Limit	Over	Read	CableAntenna	Preamp	Remark	A/Pos	T/Pos	Pol/Phase
	MHz	dBuV/m	dBuV/m	dB	dBuV	dB	dB/m	dB	cm	deg	
1	4959.94	40.71	54.00	-13.29	39.02	3.37	33.33	35.01	Average	100	200 HORIZONTAL
2	4960.02	46.06	74.00	-27.94	44.37	3.37	33.33	35.01	Peak	100	200 HORIZONTAL
3	15783.20	52.07	74.00	-21.93	43.94	6.14	37.41	35.42	Peak	100	171 HORIZONTAL
4	15787.20	39.07	54.00	-14.93	30.94	6.14	37.41	35.42	Average	100	171 HORIZONTAL

Vertical

	Freq	Level	Limit	Over	Read	CableAntenna	Preamp	Remark	A/Pos	T/Pos	Pol/Phase
	MHz	dBuV/m	dBuV/m	dB	dBuV	dB	dB/m	dB	cm	deg	
1	4959.87	54.54	74.00	-19.46	52.85	3.37	33.33	35.01	Peak	100	173 VERTICAL
2	4959.97	47.05	54.00	-6.95	45.36	3.37	33.33	35.01	Average	100	173 VERTICAL
3	15779.59	52.37	74.00	-21.63	44.24	6.14	37.41	35.42	Peak	100	263 VERTICAL
4	15779.71	39.71	54.00	-14.29	31.58	6.14	37.41	35.42	Average	100	263 VERTICAL



Temperature	25.6°C	Humidity	56%
Test Engineer	Andre Tak	Configurations	IEEE 802.11n MCS0 20MHz Ch 60 / Chain 1+ Chain 2 (2TX)
Test Date	Jan. 31, 2013		

Horizontal

	Freq	Level	Limit	Over	Read	CableAntenna	Preamp	Remark	A/Pos	T/Pos	Pol/Phase
	MHz	dBuV/m	dBuV/m	dB	dBuV	dB	dB/m	dB	cm	deg	
1	4999.95	48.53	74.00	-25.47	46.76	3.39	33.39	35.01	Peak	100	212 HORIZONTAL
2	4999.96	39.16	54.00	-14.84	37.39	3.39	33.39	35.01	Average	100	212 HORIZONTAL
3	10601.28	49.50	74.00	-24.50	41.53	5.01	38.38	35.42	Peak	120	315 HORIZONTAL
4	10602.32	36.37	54.00	-17.63	28.40	5.01	38.38	35.42	Average	120	315 HORIZONTAL
5	15890.96	37.01	54.00	-16.99	29.00	6.15	37.30	35.44	Average	100	109 HORIZONTAL
6	15892.72	50.36	74.00	-23.64	42.35	6.15	37.30	35.44	Peak	100	109 HORIZONTAL

Vertical

	Freq	Level	Limit	Over	Read	CableAntenna	Preamp	Remark	A/Pos	T/Pos	Pol/Phase
	MHz	dBuV/m	dBuV/m	dB	dBuV	dB	dB/m	dB	cm	deg	
1	5000.00	54.76	74.00	-19.24	52.98	3.39	33.40	35.01	Peak	115	55 VERTICAL
2	5000.03	48.28	54.00	-5.72	46.50	3.39	33.40	35.01	Average	115	55 VERTICAL
3	10600.28	38.70	54.00	-15.30	30.73	5.01	38.38	35.42	Average	100	316 VERTICAL
4	10600.80	51.55	74.00	-22.45	43.58	5.01	38.38	35.42	Peak	100	316 VERTICAL
5	15890.08	37.51	54.00	-16.49	29.50	6.15	37.30	35.44	Average	100	184 VERTICAL
6	15898.36	50.13	74.00	-23.87	42.13	6.15	37.29	35.44	Peak	100	184 VERTICAL

Temperature	25.6°C	Humidity	56%
Test Engineer	Andre Tak	Configurations	IEEE 802.11n MCS0 20MHz Ch 64 / Chain 1+ Chain 2 (2TX)
Test Date	Jan. 31, 2013		

Horizontal

	Freq	Level	Limit	Over	Read	Cable	Antenna	Preamp	Remark	A/Pos	T/Pos	PoI/Phase
	MHz	dBuV/m	dBuV/m	dB	dBuV	dB	dB/m	dB		cm	deg	
1	4959.97	39.54	54.00	-14.46	37.85	3.37	33.33	35.01	Average	100	136	HORIZONTAL
2	4960.02	48.12	74.00	-25.88	46.43	3.37	33.33	35.01	Peak	100	136	HORIZONTAL
3	10639.43	47.98	74.00	-26.02	39.99	5.01	38.37	35.39	Peak	100	81	HORIZONTAL
4	10640.80	36.65	54.00	-17.35	28.66	5.01	38.37	35.39	Average	100	81	HORIZONTAL
5	15959.00	37.86	54.00	-16.14	29.92	6.15	37.23	35.44	Average	100	206	HORIZONTAL
6	15959.86	50.57	74.00	-23.43	42.63	6.15	37.23	35.44	Peak	100	206	HORIZONTAL

Vertical

	Freq	Level	Limit	Over	Read	Cable	Antenna	Preamp	Remark	A/Pos	T/Pos	PoI/Phase
	MHz	dBuV/m	dBuV/m	dB	dBuV	dB	dB/m	dB		cm	deg	
1	4959.88	54.74	74.00	-19.26	53.05	3.37	33.33	35.01	Peak	103	57	VERTICAL
2	4959.96	50.95	54.00	-3.05	49.26	3.37	33.33	35.01	Average	103	57	VERTICAL
3	10639.70	47.91	74.00	-26.09	39.92	5.01	38.37	35.39	Peak	107	178	VERTICAL
4	10640.94	37.72	54.00	-16.28	29.73	5.01	38.37	35.39	Average	107	178	VERTICAL
5	15959.40	51.15	74.00	-22.85	43.21	6.15	37.23	35.44	Peak	100	272	VERTICAL
6	15960.31	37.60	54.00	-16.40	29.66	6.15	37.23	35.44	Average	100	272	VERTICAL

Temperature	25.6°C	Humidity	56%
Test Engineer	Andre Tak	Configurations	IEEE 802.11n MCS0 20MHz Ch 100 / Chain 1+ Chain 2 (2TX)
Test Date	Jan. 31, 2013		

Horizontal

	Freq	Level	Limit Line	Over Limit	Read Level	CableAntenna Loss	Antenna Factor	Preamp Factor	Remark	A/Pos	T/Pos	Pol/Phase
	MHz	dBuV/m	dBuV/m	dB	dBuV	dB	dB/m	dB		cm	deg	
1	4959.83	45.89	74.00	-28.11	44.20	3.37	33.33	35.01	Peak	100	176	HORIZONTAL
2	4959.94	38.40	54.00	-15.60	36.71	3.37	33.33	35.01	Average	100	176	HORIZONTAL
3	10999.75	35.29	54.00	-18.71	27.06	5.01	38.32	35.10	Average	100	58	HORIZONTAL
4	11000.46	49.38	74.00	-24.62	41.15	5.01	38.32	35.10	Peak	100	58	HORIZONTAL

Vertical

	Freq	Level	Limit Line	Over Limit	Read Level	CableAntenna Loss	Antenna Factor	Preamp Factor	Remark	A/Pos	T/Pos	Pol/Phase
	MHz	dBuV/m	dBuV/m	dB	dBuV	dB	dB/m	dB		cm	deg	
1	4959.98	47.56	54.00	-6.44	45.87	3.37	33.33	35.01	Average	114	180	VERTICAL
2	4960.05	53.12	74.00	-20.88	51.43	3.37	33.33	35.01	Peak	114	180	VERTICAL
3	11000.00	49.01	74.00	-24.99	40.80	5.01	38.30	35.10	Peak	100	223	VERTICAL
4	11000.17	36.85	54.00	-17.15	28.64	5.01	38.30	35.10	Average	100	223	VERTICAL



Temperature	25.6°C	Humidity	56%
Test Engineer	Andre Tak	Configurations	IEEE 802.11n MCS0 20MHz Ch 116 / Chain 1+ Chain 2 (2TX)
Test Date	Jan. 31, 2013		

Horizontal

	Freq	Level	Limit Line	Over Limit	Read Level	CableAntenna Loss	Antenna Factor	Preamp Factor	Remark	A/Pos	T/Pos	Pol/Phase
	MHz	dBuV/m	dBuV/m	dB	dBuV	dB	dB/m	dB		cm	deg	
1	4959.81	44.67	74.00	-29.33	42.98	3.37	33.33	35.01	Peak	100	138	HORIZONTAL
2	4959.94	36.31	54.00	-17.69	34.62	3.37	33.33	35.01	Average	100	138	HORIZONTAL
3	11156.72	48.54	74.00	-25.46	40.21	5.04	38.45	35.16	Peak	100	223	HORIZONTAL
4	11160.80	35.55	54.00	-18.45	27.21	5.04	38.47	35.17	Average	100	223	HORIZONTAL

Vertical

	Freq	Level	Limit Line	Over Limit	Read Level	CableAntenna Loss	Antenna Factor	Preamp Factor	Remark	A/Pos	T/Pos	Pol/Phase
	MHz	dBuV/m	dBuV/m	dB	dBuV	dB	dB/m	dB		cm	deg	
1	4959.86	52.93	74.00	-21.07	51.24	3.37	33.33	35.01	Peak	132	55	VERTICAL
2	4959.99	47.48	54.00	-6.52	45.79	3.37	33.33	35.01	Average	132	55	VERTICAL
3	11159.80	38.94	54.00	-15.06	30.60	5.04	38.47	35.17	Average	121	305	VERTICAL
4	11161.04	53.31	74.00	-20.69	44.97	5.04	38.47	35.17	Peak	121	305	VERTICAL



Temperature	25.6°C	Humidity	56%
Test Engineer	Andre Tak	Configurations	IEEE 802.11n MCS0 20MHz Ch 140 / Chain 1+ Chain 2 (2TX)
Test Date	Jan. 31, 2013		

Horizontal

	Freq	Level	Limit	Over	Read	CableAntenna	Preamp	Remark	A/Pos	T/Pos	Pol/Phase
	MHz	dBuV/m	dBuV/m	dB	dBuV	dB	dB/m	dB	cm	deg	
1	4959.91	38.58	54.00	-15.42	36.89	3.37	33.33	35.01	Average	115	144 HORIZONTAL
2	4959.94	46.40	74.00	-27.60	44.71	3.37	33.33	35.01	Peak	115	144 HORIZONTAL
3	11399.70	49.96	74.00	-24.04	41.41	5.10	38.70	35.25	Peak	101	109 HORIZONTAL
4	11400.68	36.18	54.00	-17.82	27.63	5.10	38.70	35.25	Average	101	109 HORIZONTAL

Vertical

	Freq	Level	Limit	Over	Read	CableAntenna	Preamp	Remark	A/Pos	T/Pos	Pol/Phase
	MHz	dBuV/m	dBuV/m	dB	dBuV	dB	dB/m	dB	cm	deg	
1	4959.98	49.04	54.00	-4.96	47.35	3.37	33.33	35.01	Average	130	58 VERTICAL
2	4960.02	54.07	74.00	-19.93	52.38	3.37	33.33	35.01	Peak	130	58 VERTICAL
3	11400.34	36.56	54.00	-17.44	28.01	5.10	38.70	35.25	Average	101	275 VERTICAL
4	11400.76	49.77	74.00	-24.23	41.22	5.10	38.70	35.25	Peak	101	360 VERTICAL



Temperature	25.6°C	Humidity	56%
Test Engineer	Andre Tak	Configurations	IEEE 802.11n MCS0 40MHz Ch 38 / Chain 1+ Chain 2 (2TX)
Test Date	Jan. 31, 2013		

Horizontal

	Freq	Level	Limit	Over	Read	CableAntenna	Preamp	Remark	A/Pos	T/Pos	Pol/Phase
	MHz	dBuV/m	dBuV/m	dB	dBuV	dB	dB/m	dB	cm	deg	
1	4959.99	38.01	54.00	-15.99	36.32	3.37	33.33	35.01	Average	100	324 HORIZONTAL
2	4960.04	46.16	74.00	-27.84	44.47	3.37	33.33	35.01	Peak	100	324 HORIZONTAL
3	15569.41	37.25	54.00	-16.75	28.82	6.13	37.63	35.33	Average	109	288 HORIZONTAL
4	15569.65	50.65	74.00	-23.35	42.22	6.13	37.63	35.33	Peak	109	288 HORIZONTAL

Vertical

	Freq	Level	Limit	Over	Read	CableAntenna	Preamp	Remark	A/Pos	T/Pos	Pol/Phase
	MHz	dBuV/m	dBuV/m	dB	dBuV	dB	dB/m	dB	cm	deg	
1	4959.93	52.10	74.00	-21.90	50.41	3.37	33.33	35.01	Peak	114	176 VERTICAL
2	4959.97	46.83	54.00	-7.17	45.14	3.37	33.33	35.01	Average	114	176 VERTICAL
3	15570.09	50.43	74.00	-23.57	41.98	6.13	37.65	35.33	Peak	100	225 VERTICAL
4	15570.38	37.30	54.00	-16.70	28.85	6.13	37.65	35.33	Average	100	225 VERTICAL

Temperature	25.6°C	Humidity	56%
Test Engineer	Andre Tak	Configurations	IEEE 802.11n MCS0 40MHz Ch 46 / Chain 1+ Chain 2 (2TX)
Test Date	Jan. 31, 2013		

Horizontal

	Freq	Level	Limit	Over	Read	CableAntenna	Preamp	Remark	A/Pos	T/Pos	PoI/Phase
	MHz	dBuV/m	dBuV/m	dB	dBuV	dB	dB/m	dB	cm	deg	
1	4959.89	47.76	74.00	-26.24	46.07	3.37	33.33	35.01	Peak	100	301 HORIZONTAL
2	4959.98	40.04	54.00	-13.96	38.35	3.37	33.33	35.01	Average	100	301 HORIZONTAL
3	15689.72	51.42	74.00	-22.58	43.14	6.14	37.51	35.37	Peak	101	196 HORIZONTAL
4	15690.20	38.04	54.00	-15.96	29.76	6.14	37.51	35.37	Average	101	196 HORIZONTAL

Vertical

	Freq	Level	Limit	Over	Read	CableAntenna	Preamp	Remark	A/Pos	T/Pos	PoI/Phase
	MHz	dBuV/m	dBuV/m	dB	dBuV	dB	dB/m	dB	cm	deg	
1	4959.97	49.49	54.00	-4.51	47.80	3.37	33.33	35.01	Average	100	174 VERTICAL
2	4959.99	53.82	74.00	-20.18	52.13	3.37	33.33	35.01	Peak	100	174 VERTICAL
3	15689.30	52.26	74.00	-21.74	43.98	6.14	37.51	35.37	Peak	100	251 VERTICAL
4	15690.72	38.16	54.00	-15.84	29.89	6.14	37.51	35.38	Average	100	251 VERTICAL



Temperature	25.6°C	Humidity	56%
Test Engineer	Andre Tak	Configurations	IEEE 802.11n MCS0 40MHz Ch 54 / Chain 1+ Chain 2 (2TX)
Test Date	Jan. 31, 2013		

Horizontal

	Freq	Level	Limit Line	Over Limit	Read Level	CableAntenna Loss	Antenna Factor	Preamp Factor	Remark	A/Pos	T/Pos	PoI/Phase
	MHz	dBuV/m	dBuV/m	dB	dBuV	dB	dB/m	dB		cm	deg	
1	4959.85	47.02	74.00	-26.98	45.33	3.37	33.33	35.01	Peak	100	150	HORIZONTAL
2	4959.93	39.46	54.00	-14.54	37.77	3.37	33.33	35.01	Average	100	150	HORIZONTAL
3	15810.11	39.27	54.00	-14.73	31.17	6.14	37.39	35.43	Average	107	121	HORIZONTAL
4	15810.54	51.30	74.00	-22.70	43.22	6.14	37.37	35.43	Peak	107	121	HORIZONTAL

Vertical

	Freq	Level	Limit Line	Over Limit	Read Level	CableAntenna Loss	Antenna Factor	Preamp Factor	Remark	A/Pos	T/Pos	PoI/Phase
	MHz	dBuV/m	dBuV/m	dB	dBuV	dB	dB/m	dB		cm	deg	
1	4959.97	46.33	54.00	-7.67	44.64	3.37	33.33	35.01	Average	100	176	VERTICAL
2	4959.98	52.50	74.00	-21.50	50.81	3.37	33.33	35.01	Peak	100	176	VERTICAL
3	15810.14	40.90	54.00	-13.10	32.80	6.14	37.39	35.43	Average	101	162	VERTICAL
4	15810.14	53.42	74.00	-20.58	45.32	6.14	37.39	35.43	Peak	101	162	VERTICAL



Temperature	25.6°C	Humidity	56%
Test Engineer	Andre Tak	Configurations	IEEE 802.11n MCS0 40MHz Ch 62 / Chain 1+ Chain 2 (2TX)
Test Date	Jan. 31, 2013		

Horizontal

	Freq	Level	Limit Line	Over Limit	Read Level	Cable Loss	Antenna Factor	Preamp Factor	Remark	A/Pos	T/Pos	Pol/Phase
	MHz	dBuV/m	dBuV/m	dB	dBuV	dB	dB/m	dB		cm	deg	
1	4959.84	47.79	74.00	-26.21	46.10	3.37	33.33	35.01	Peak	100	133	HORIZONTAL
2	4959.98	39.22	54.00	-14.78	37.53	3.37	33.33	35.01	Average	100	133	HORIZONTAL
3	10581.20	47.59	74.00	-26.41	39.64	5.01	38.38	35.44	Peak	100	224	HORIZONTAL
4	10598.80	35.18	54.00	-18.82	27.21	5.01	38.38	35.42	Average	100	224	HORIZONTAL
5	15841.60	50.65	74.00	-23.35	42.59	6.14	37.36	35.44	Peak	100	144	HORIZONTAL
6	15854.40	38.28	54.00	-15.72	30.25	6.14	37.34	35.45	Average	100	144	HORIZONTAL

Vertical

	Freq	Level	Limit Line	Over Limit	Read Level	Cable Loss	Antenna Factor	Preamp Factor	Remark	A/Pos	T/Pos	Pol/Phase
	MHz	dBuV/m	dBuV/m	dB	dBuV	dB	dB/m	dB		cm	deg	
1	4960.00	52.31	74.00	-21.69	50.62	3.37	33.33	35.01	Peak	102	173	VERTICAL
2	4960.01	48.62	54.00	-5.38	46.93	3.37	33.33	35.01	Average	102	173	VERTICAL
3	10586.40	47.14	74.00	-26.86	39.19	5.01	38.38	35.44	Peak	100	243	VERTICAL
4	10604.00	34.79	54.00	-19.21	26.82	5.01	38.38	35.42	Average	100	243	VERTICAL
5	15882.40	50.48	74.00	-23.52	42.47	6.15	37.30	35.44	Peak	101	165	VERTICAL
6	15912.40	37.71	54.00	-16.29	29.71	6.15	37.29	35.44	Average	101	165	VERTICAL



Temperature	25.6°C	Humidity	56%
Test Engineer	Andre Tak	Configurations	IEEE 802.11n MCS0 40MHz Ch 102 / Chain 1+ Chain 2 (2TX)
Test Date	Jan. 31, 2013		

Horizontal

	Freq	Level	Limit	Over	Read	Cable	Antenna	Preamp	Remark	A/Pos	T/Pos	Pol/Phase
	MHz	dBuV/m	dBuV/m	dB	dBuV	dB	dB/m	dB		cm	deg	
1	4959.98	39.08	54.00	-14.92	37.39	3.37	33.33	35.01	Average	100	313	HORIZONTAL
2	4959.99	46.85	74.00	-27.15	45.16	3.37	33.33	35.01	Peak	100	313	HORIZONTAL
3	11008.40	49.07	74.00	-24.93	40.84	5.01	38.33	35.11	Peak	105	97	HORIZONTAL
4	11038.80	36.39	54.00	-17.61	28.15	5.02	38.34	35.12	Average	105	97	HORIZONTAL

Vertical

	Freq	Level	Limit	Over	Read	Cable	Antenna	Preamp	Remark	A/Pos	T/Pos	Pol/Phase
	MHz	dBuV/m	dBuV/m	dB	dBuV	dB	dB/m	dB		cm	deg	
1	4959.96	53.94	74.00	-20.06	52.25	3.37	33.33	35.01	Peak	143	174	VERTICAL
2	4959.99	48.64	54.00	-5.36	46.95	3.37	33.33	35.01	Average	143	174	VERTICAL
3	11023.20	36.19	54.00	-17.81	27.95	5.02	38.33	35.11	Average	101	203	VERTICAL
4	11077.60	48.91	74.00	-25.09	40.63	5.03	38.38	35.13	Peak	101	203	VERTICAL

Temperature	25.6°C	Humidity	56%
Test Engineer	Andre Tak	Configurations	IEEE 802.11n MCS0 40MHz Ch 110 / Chain 1+ Chain 2 (2TX)
Test Date	Jan. 31, 2013		

Horizontal

	Freq	Level	Limit	Over	Read	CableAntenna	Preamp	Remark	A/Pos	T/Pos	Pol/Phase
	MHz	dBuV/m	dBuV/m	dB	dBuV	dB	dB/m	dB	cm	deg	
1	4959.94	39.49	54.00	-14.51	37.80	3.37	33.33	35.01	Average	100	299 HORIZONTAL
2	4959.97	46.58	74.00	-27.42	44.89	3.37	33.33	35.01	Peak	100	299 HORIZONTAL
3	11099.92	38.01	54.00	-15.99	29.72	5.03	38.40	35.14	Average	100	156 HORIZONTAL
4	11104.28	49.36	74.00	-24.64	41.07	5.03	38.40	35.14	Peak	100	156 HORIZONTAL

Vertical

	Freq	Level	Limit	Over	Read	CableAntenna	Preamp	Remark	A/Pos	T/Pos	Pol/Phase
	MHz	dBuV/m	dBuV/m	dB	dBuV	dB	dB/m	dB	cm	deg	
1	4959.94	47.02	54.00	-6.98	45.33	3.37	33.33	35.01	Average	142	177 VERTICAL
2	4960.03	52.16	74.00	-21.84	50.47	3.37	33.33	35.01	Peak	142	177 VERTICAL
3	11100.28	49.19	74.00	-24.81	40.90	5.03	38.40	35.14	Peak	100	229 VERTICAL
4	11101.44	37.22	54.00	-16.78	28.93	5.03	38.40	35.14	Average	100	229 VERTICAL

Temperature	25.6°C	Humidity	56%
Test Engineer	Andre Tak	Configurations	IEEE 802.11n MCS0 40MHz Ch 134 / Chain 1+ Chain 2 (2TX)
Test Date	Jan. 31, 2013		

Horizontal

	Freq	Level	Limit Line	Over Limit	Read Level	CableAntenna Loss	Antenna Factor	Preamp Factor	Remark	A/Pos	T/Pos	PoI/Phase
	MHz	dBuV/m	dBuV/m	dB	dBuV	dB	dB/m	dB		cm	deg	
1	4959.97	46.90	74.00	-27.10	45.21	3.37	33.33	35.01	Peak	101	319	HORIZONTAL
2	4960.00	38.34	54.00	-15.66	36.65	3.37	33.33	35.01	Average	101	319	HORIZONTAL
3	11346.44	48.90	74.00	-25.10	40.40	5.09	38.65	35.24	Peak	101	294	HORIZONTAL
4	11346.84	35.30	54.00	-18.70	26.80	5.09	38.65	35.24	Average	101	294	HORIZONTAL

Vertical

	Freq	Level	Limit Line	Over Limit	Read Level	CableAntenna Loss	Antenna Factor	Preamp Factor	Remark	A/Pos	T/Pos	PoI/Phase
	MHz	dBuV/m	dBuV/m	dB	dBuV	dB	dB/m	dB		cm	deg	
1	4959.98	49.82	54.00	-4.18	48.13	3.37	33.33	35.01	Average	143	172	VERTICAL
2	4960.08	54.21	74.00	-19.79	52.52	3.37	33.33	35.01	Peak	143	172	VERTICAL
3	11335.56	36.17	54.00	-17.83	27.69	5.08	38.63	35.23	Average	101	259	VERTICAL
4	11347.00	48.58	74.00	-25.42	40.08	5.09	38.65	35.24	Peak	101	259	VERTICAL

Note:

The amplitude of spurious emissions that are attenuated by more than 20dB below the permissible value has no need to be reported.

Emission level (dBuV/m) = 20 log Emission level (uV/m).

Corrected Reading: Antenna Factor + Cable Loss + Read Level - Preamp Factor = Level.



Temperature	25.6°C	Humidity	56%
Test Engineer	Andre Tak	Configurations	IEEE 802.11a Ch 36 / Chain 1+ Chain 2 (2TX)
Test Date	Jan. 31, 2013		

Horizontal

	Freq	Level	Limit	Over	Read	Cable	Antenna	Preamp	Remark	A/Pos	T/Pos	Pol/Phase
	MHz	dBuV/m	dBuV/m	dB	dBuV	Loss	Factor	Factor		cm	deg	
1	15540.04	36.83	54.00	-17.17	28.36	6.13	37.65	35.31	Average	100	141	HORIZONTAL
2	15540.04	48.50	74.00	-25.50	40.03	6.13	37.65	35.31	Peak	100	141	HORIZONTAL

Vertical

	Freq	Level	Limit	Over	Read	Cable	Antenna	Preamp	Remark	A/Pos	T/Pos	Pol/Phase
	MHz	dBuV/m	dBuV/m	dB	dBuV	Loss	Factor	Factor		cm	deg	
1	15539.96	37.03	54.00	-16.97	28.52	6.13	37.69	35.31	Average	100	268	VERTICAL
2	15539.96	47.80	74.00	-26.20	39.29	6.13	37.69	35.31	Peak	100	268	VERTICAL



Temperature	25.6°C	Humidity	56%
Test Engineer	Andre Tak	Configurations	IEEE 802.11a Ch 40 / Chain 1+ Chain 2 (2TX)
Test Date	Jan. 31, 2013		

Horizontal

	Freq	Level	Limit Line	Over Limit	Read Level	Cable Loss	Antenna Factor	Preamp Factor	Remark	A/Pos	T/Pos	Pol/Phase
	MHz	dBuV/m	dBuV/m	dB	dBuV	dB	dB/m	dB		cm	deg	
1	4959.96	42.73	54.00	-11.27	41.04	3.37	33.33	35.01	Average	102	221	HORIZONTAL
2	4959.96	47.80	74.00	-26.20	46.11	3.37	33.33	35.01	Peak	102	221	HORIZONTAL
3	15600.00	37.38	54.00	-16.62	28.99	6.13	37.60	35.34	Average	100	236	HORIZONTAL
4	15600.00	48.75	74.00	-25.25	40.36	6.13	37.60	35.34	Peak	100	236	HORIZONTAL

Vertical

	Freq	Level	Limit Line	Over Limit	Read Level	Cable Loss	Antenna Factor	Preamp Factor	Remark	A/Pos	T/Pos	Pol/Phase
	MHz	dBuV/m	dBuV/m	dB	dBuV	dB	dB/m	dB		cm	deg	
1	4959.97	52.66	54.00	-1.34	50.97	3.37	33.33	35.01	Average	101	188	VERTICAL
2	4959.97	56.97	74.00	-17.03	55.28	3.37	33.33	35.01	Peak	101	188	VERTICAL
3	15600.00	37.18	54.00	-16.82	28.79	6.13	37.60	35.34	Average	100	147	VERTICAL
4	15600.00	48.49	74.00	-25.51	40.10	6.13	37.60	35.34	Peak	100	147	VERTICAL

Temperature	25.6°C	Humidity	56%
Test Engineer	Andre Tak	Configurations	IEEE 802.11a Ch 48 / Chain 1+ Chain 2 (2TX)
Test Date	Jan. 31, 2013		

Horizontal

	Freq	Level	Limit Line	Over Limit	Read Level	Cable Loss	Antenna Factor	Preamp Factor	Remark	A/Pos	T/Pos	Pol/Phase
	MHz	dBuV/m	dBuV/m	dB	dBuV	dB	dB/m	dB		cm	deg	
1	4999.87	44.13	74.00	-29.87	42.36	3.39	33.39	35.01	Peak	100	202	HORIZONTAL
2	4999.95	36.67	54.00	-17.33	34.90	3.39	33.39	35.01	Average	100	202	HORIZONTAL
3	15720.00	38.03	54.00	-15.97	29.80	6.14	37.48	35.39	Average	101	227	HORIZONTAL
4	15720.00	49.00	74.00	-25.00	40.77	6.14	37.48	35.39	Peak	101	227	HORIZONTAL

Vertical

	Freq	Level	Limit Line	Over Limit	Read Level	Cable Loss	Antenna Factor	Preamp Factor	Remark	A/Pos	T/Pos	Pol/Phase
	MHz	dBuV/m	dBuV/m	dB	dBuV	dB	dB/m	dB		cm	deg	
1	4959.92	52.16	74.00	-21.84	50.47	3.37	33.33	35.01	Peak	100	163	VERTICAL
2	4959.97	46.32	54.00	-7.68	44.63	3.37	33.33	35.01	Average	100	163	VERTICAL
3	15720.00	38.26	54.00	-15.74	30.03	6.14	37.48	35.39	Average	101	259	VERTICAL
4	15720.00	48.57	74.00	-25.43	40.34	6.14	37.48	35.39	Peak	101	259	VERTICAL



Temperature	25.6°C	Humidity	56%
Test Engineer	Andre Tak	Configurations	IEEE 802.11a Ch 52 / Chain 1+ Chain 2 (2TX)
Test Date	Jan. 31, 2013		

Horizontal

	Freq	Level	Limit Line	Over Limit	Read Level	Cable Loss	Antenna Factor	Preamp Factor	Remark	A/Pos	T/Pos	Pol/Phase
	MHz	dBuV/m	dBuV/m	dB	dBuV	dB	dB/m	dB		cm	deg	
1	4999.93	36.50	54.00	-17.50	34.73	3.39	33.39	35.01	Average	100	268	HORIZONTAL
2	4999.93	45.01	74.00	-28.99	43.24	3.39	33.39	35.01	Peak	100	268	HORIZONTAL
3	15780.00	38.41	54.00	-15.59	30.28	6.14	37.41	35.42	Average	100	331	HORIZONTAL
4	15780.00	51.75	74.00	-22.25	43.62	6.14	37.41	35.42	Peak	100	331	HORIZONTAL

Vertical

	Freq	Level	Limit Line	Over Limit	Read Level	Cable Loss	Antenna Factor	Preamp Factor	Remark	A/Pos	T/Pos	Pol/Phase
	MHz	dBuV/m	dBuV/m	dB	dBuV	dB	dB/m	dB		cm	deg	
1	4999.95	49.52	54.00	-4.48	47.74	3.39	33.40	35.01	Average	100	189	VERTICAL
2	4999.95	57.35	74.00	-16.65	55.57	3.39	33.40	35.01	Peak	100	189	VERTICAL
3	15780.00	38.63	54.00	-15.37	30.50	6.14	37.41	35.42	Average	100	274	VERTICAL
4	15780.00	50.53	74.00	-23.47	42.40	6.14	37.41	35.42	Peak	100	274	VERTICAL



Temperature	25.6°C	Humidity	56%
Test Engineer	Andre Tak	Configurations	IEEE 802.11a Ch 60 / Chain 1+ Chain 2 (2TX)
Test Date	Jan. 31, 2013		

Horizontal

	Freq	Level	Limit Line	Over Limit	Read Level	Cable Loss	Antenna Factor	Preamp Factor	Remark	A/Pos	T/Pos	Pol/Phase
	MHz	dBuV/m	dBuV/m	dB	dBuV	dB	dB/m	dB		cm	deg	
1	4960.00	37.60	54.00	-16.40	35.91	3.37	33.33	35.01	Average	100	231	HORIZONTAL
2	4960.00	44.65	74.00	-29.35	42.96	3.37	33.33	35.01	Peak	100	231	HORIZONTAL
3	10600.01	35.77	54.00	-18.23	27.80	5.01	38.38	35.42	Average	100	287	HORIZONTAL
4	10600.01	46.60	74.00	-27.40	38.63	5.01	38.38	35.42	Peak	100	287	HORIZONTAL
5	15900.01	37.16	54.00	-16.84	29.16	6.15	37.29	35.44	Average	100	292	HORIZONTAL
6	15900.01	48.97	74.00	-25.03	40.97	6.15	37.29	35.44	Peak	100	292	HORIZONTAL

Vertical

	Freq	Level	Limit Line	Over Limit	Read Level	Cable Loss	Antenna Factor	Preamp Factor	Remark	A/Pos	T/Pos	Pol/Phase
	MHz	dBuV/m	dBuV/m	dB	dBuV	dB	dB/m	dB		cm	deg	
1	4959.98	52.55	54.00	-1.45	50.86	3.37	33.33	35.01	Average	100	189	VERTICAL
2	4959.98	56.98	74.00	-17.02	55.29	3.37	33.33	35.01	Peak	100	189	VERTICAL
3	10600.01	41.17	54.00	-12.83	33.20	5.01	38.38	35.42	Average	100	329	VERTICAL
4	10600.01	52.83	74.00	-21.17	44.86	5.01	38.38	35.42	Peak	100	329	VERTICAL
5	15900.01	37.91	54.00	-16.09	29.91	6.15	37.29	35.44	Average	100	261	VERTICAL
6	15900.01	48.84	74.00	-25.16	40.84	6.15	37.29	35.44	Peak	100	261	VERTICAL



Temperature	25.6°C	Humidity	56%
Test Engineer	Andre Tak	Configurations	IEEE 802.11a Ch 64 / Chain 1+ Chain 2 (2TX)
Test Date	Jan. 31, 2013		

Horizontal

	Freq	Level	Limit Line	Over Limit	Read Level	CableAntenna Loss	Antenna Factor	Preamp Factor	Remark	A/Pos	T/Pos	Pol/Phase
	MHz	dBuV/m	dBuV/m	dB	dBuV	dB	dB/m	dB		cm	deg	
1	5519.98	38.65	54.00	-15.35	35.94	3.54	34.27	35.10	Average	101	217	HORIZONTAL
2	5519.98	45.83	74.00	-28.17	43.12	3.54	34.27	35.10	Peak	101	217	HORIZONTAL
3	10640.00	34.75	54.00	-19.25	26.76	5.01	38.37	35.39	Average	101	219	HORIZONTAL
4	10640.00	45.81	74.00	-28.19	37.82	5.01	38.37	35.39	Peak	101	219	HORIZONTAL

Vertical

	Freq	Level	Limit Line	Over Limit	Read Level	CableAntenna Loss	Antenna Factor	Preamp Factor	Remark	A/Pos	T/Pos	Pol/Phase
	MHz	dBuV/m	dBuV/m	dB	dBuV	dB	dB/m	dB		cm	deg	
1	5520.00	46.21	54.00	-7.79	43.47	3.54	34.30	35.10	Average	101	359	VERTICAL
2	5520.00	52.12	74.00	-21.88	49.38	3.54	34.30	35.10	Peak	101	359	VERTICAL
3	10640.00	35.04	54.00	-18.96	27.05	5.01	38.37	35.39	Average	101	275	VERTICAL
4	10640.00	44.97	74.00	-29.03	36.98	5.01	38.37	35.39	Peak	101	275	VERTICAL



Temperature	25.6°C	Humidity	56%
Test Engineer	Andre Tak	Configurations	IEEE 802.11a Ch 100 / Chain 1+ Chain 2 (2TX)
Test Date	Jan. 31, 2013		

Horizontal

	Freq	Level	Limit	Over	Read	Cable	Antenna	Preamp	Remark	A/Pos	T/Pos	Pol/Phase
	MHz	dBuV/m	dBuV/m	dB	dBuV	Loss	Factor	Factor		cm	deg	
1	11000.00	35.57	54.00	-18.43	27.34	5.01	38.32	35.10	Average	100	215	HORIZONTAL
2	11000.00	45.89	74.00	-28.11	37.66	5.01	38.32	35.10	Peak	100	215	HORIZONTAL

Vertical

	Freq	Level	Limit	Over	Read	Cable	Antenna	Preamp	Remark	A/Pos	T/Pos	Pol/Phase
	MHz	dBuV/m	dBuV/m	dB	dBuV	Loss	Factor	Factor		cm	deg	
1	11000.00	36.24	54.00	-17.76	28.03	5.01	38.30	35.10	Average	100	278	VERTICAL
2	11000.00	46.27	74.00	-27.73	38.06	5.01	38.30	35.10	Peak	100	278	VERTICAL



Temperature	25.6°C	Humidity	56%
Test Engineer	Andre Tak	Configurations	IEEE 802.11a Ch 116 / Chain 1+ Chain 2 (2TX)
Test Date	Jan. 31, 2013		

Horizontal

	Freq	Level	Limit Line	Over Limit	Read Level	Cable Loss	Antenna Factor	Preamp Factor	Remark	A/Pos	T/Pos	PoI/Phase
	MHz	dBuV/m	dBuV/m	dB	dBuV	dB	dB/m	dB		cm	deg	
1	4999.98	39.12	54.00	-14.88	37.35	3.39	33.39	35.01	Average	100	252	HORIZONTAL
2	4999.98	46.44	74.00	-27.56	44.67	3.39	33.39	35.01	Peak	100	252	HORIZONTAL
3	11160.01	36.23	54.00	-17.77	27.89	5.04	38.47	35.17	Average	100	212	HORIZONTAL
4	11160.01	47.58	74.00	-26.42	39.24	5.04	38.47	35.17	Peak	100	212	HORIZONTAL

Vertical

	Freq	Level	Limit Line	Over Limit	Read Level	Cable Loss	Antenna Factor	Preamp Factor	Remark	A/Pos	T/Pos	PoI/Phase
	MHz	dBuV/m	dBuV/m	dB	dBuV	dB	dB/m	dB		cm	deg	
1	4999.98	48.35	54.00	-5.65	46.57	3.39	33.40	35.01	Average	100	235	VERTICAL
2	4999.98	51.79	74.00	-22.21	50.01	3.39	33.40	35.01	Peak	100	235	VERTICAL
3	11160.01	41.60	54.00	-12.40	33.26	5.04	38.47	35.17	Average	100	303	VERTICAL
4	11160.01	52.69	74.00	-21.31	44.35	5.04	38.47	35.17	Peak	100	303	VERTICAL



Temperature	25.6°C	Humidity	56%
Test Engineer	Andre Tak	Configurations	IEEE 802.11a Ch 140 / Chain 1+ Chain 2 (2TX)
Test Date	Jan. 31, 2013		

Horizontal

	Freq	Level	Limit Line	Over Limit	Read Level	Cable Loss	Antenna Factor	Preamp Factor	Remark	A/Pos	T/Pos	PoI/Phase
	MHz	dBuV/m	dBuV/m	dB	dBuV	dB	dB/m	dB		cm	deg	
1	4959.98	38.80	54.00	-15.20	37.11	3.37	33.33	35.01	Average	100	253	HORIZONTAL
2	4959.98	43.54	74.00	-30.46	41.85	3.37	33.33	35.01	Peak	100	253	HORIZONTAL
3	11400.01	35.82	54.00	-18.18	27.27	5.10	38.70	35.25	Average	100	206	HORIZONTAL
4	11400.01	46.88	74.00	-27.12	38.33	5.10	38.70	35.25	Peak	100	206	HORIZONTAL

Vertical

	Freq	Level	Limit Line	Over Limit	Read Level	Cable Loss	Antenna Factor	Preamp Factor	Remark	A/Pos	T/Pos	PoI/Phase
	MHz	dBuV/m	dBuV/m	dB	dBuV	dB	dB/m	dB		cm	deg	
1	4959.97	47.32	54.00	-6.68	45.63	3.37	33.33	35.01	Average	100	174	VERTICAL
2	4959.97	50.25	74.00	-23.75	48.56	3.37	33.33	35.01	Peak	100	174	VERTICAL
3	11400.01	36.69	54.00	-17.31	28.14	5.10	38.70	35.25	Average	100	277	VERTICAL
4	11400.01	47.37	74.00	-26.63	38.82	5.10	38.70	35.25	Peak	100	277	VERTICAL

Note:

The amplitude of spurious emissions that are attenuated by more than 20dB below the permissible value has no need to be reported.

Emission level (dBuV/m) = 20 log Emission level (uV/m).

Corrected Reading: Antenna Factor + Cable Loss + Read Level - Preamp Factor = Level.

4.7. Band Edge Emissions Measurement

4.7.1. Limit

For transmitters operating in the 5.15-5.35 GHz band: all emissions outside of the 5.15-5.35 GHz band shall not exceed an EIRP of -27 dBm/MHz (68.3dBuV/m at 3m). For transmitters operating in the 5.470-5.725 GHz band: all emissions outside of the 5.470-5.725 GHz band shall not exceed an EIRP of -27 dBm/MHz (68.3dBuV/m at 3m). For frequencies 10 MHz or greater above or below the band edge, emissions shall not exceed an EIRP of -27 dBm/MHz (68.3dBuV/m at 3m). In addition, In case the emission fall within the restricted band specified on 15.205(a), then the 15.209(a) limit in the table below has to be followed.

Frequencies (MHz)	Field Strength (micровolts/meter)	Measurement Distance (meters)
0.009~0.490	2400/F(KHz)	300
0.490~1.705	24000/F(KHz)	30
1.705~30.0	30	30
30~88	100	3
88~216	150	3
216~960	200	3
Above 960	500	3

4.7.2. Measuring Instruments and Setting

Please refer to section 5 of equipments list in this report. The following table is the setting of the spectrum analyzer.

Spectrum Parameter	Setting
Attenuation	Auto
Span Frequency	100 MHz
RB / VB (Emission in restricted band)	1MHz / 3MHz for Peak, 1 MHz / 10Hz for Average
RB / VB (Emission in non-restricted band)	1MHz / 3MHz for Peak

4.7.3. Test Procedures

1. The test procedure is the same as section 4.6.3, only the frequency range investigated is limited to 100MHz around bandedges.

4.7.4. Test Setup Layout

This test setup layout is the same as that shown in section 4.6.4.

4.7.5. Test Deviation

There is no deviation with the original standard.

4.7.6. EUT Operation during Test

The EUT was programmed to be in continuously transmitting mode.

4.7.7. Test Result of Band Edge and Fundamental Emissions

Temperature	25.6°C	Humidity	56%
Test Engineer	Andre Tak	Configurations	IEEE 802.11n MCS0 20MHz Ch 36, 40, 48 / Chain 1+ Chain 2 (2TX)
Test Date	Jan. 31, 2013		

Channel 36

	Freq	Level	Limit Line	Over Limit	Read Level	CableAntenna Loss	Antenna Factor	Preamp Factor	Remark	A/Pos	T/Pos	Pol/Phase
	MHz	dBuV/m	dBuV/m	dB	dBuV	dB	dB/m	dB		cm	deg	
1	5149.00	71.55	74.00	-2.45	34.45	3.43	33.67	0.00	Peak	100	340	VERTICAL
2	5150.00	53.66	54.00	-0.34	16.56	3.43	33.67	0.00	Average	130	339	VERTICAL
3	5183.40	126.21			89.04	3.44	33.73	0.00	Peak	100	340	VERTICAL
4	5184.40	104.29			67.12	3.44	33.73	0.00	Average	130	339	VERTICAL

Item 3, 4 are the fundamental frequency at 5180 MHz.

Channel 40

	Freq	Level	Limit Line	Over Limit	Read Level	CableAntenna Loss	Antenna Factor	Preamp Factor	Remark	A/Pos	T/Pos	Pol/Phase
	MHz	dBuV/m	dBuV/m	dB	dBuV	dB	dB/m	dB		cm	deg	
1	5149.60	69.79	74.00	-4.21	32.69	3.43	33.67	0.00	Peak	127	341	VERTICAL
2	5150.00	53.43	54.00	-0.57	16.33	3.43	33.67	0.00	Average	127	341	VERTICAL
3	5194.80	106.28			69.07	3.45	33.76	0.00	Average	127	341	VERTICAL
4	5195.60	117.13			79.92	3.45	33.76	0.00	Peak	127	341	VERTICAL

Item 3, 4 are the fundamental frequency at 5200 MHz.

Channel 48

	Freq	Level	Limit Line	Over Limit	Read Level	CableAntenna Loss	Antenna Factor	Preamp Factor	Remark	A/Pos	T/Pos	Pol/Phase
	MHz	dBuV/m	dBuV/m	dB	dBuV	dB	dB/m	dB		cm	deg	
1	5119.40	42.11	54.00	-11.89	5.07	3.43	33.61	0.00	Average	130	13	VERTICAL
2	5139.80	57.36	74.00	-16.64	20.29	3.43	33.64	0.00	Peak	130	13	VERTICAL
3	5234.00	107.55			70.27	3.46	33.82	0.00	Average	130	13	VERTICAL
4	5234.00	117.96			80.68	3.46	33.82	0.00	Peak	130	13	VERTICAL
5	5350.00	41.69	54.00	-12.31	4.17	3.49	34.03	0.00	Average	130	13	VERTICAL
6	5362.00	54.13	74.00	-19.87	16.61	3.49	34.03	0.00	Peak	130	13	VERTICAL

Item 3, 4 are the fundamental frequency at 5240 MHz.

Temperature	25.6°C	Humidity	56%
Test Engineer	Andre Tak	Configurations	IEEE 802.11n MCS0 20MHz Ch 52, 60, 64 / Chain 1+ Chain 2 (2TX)
Test Date	Jan. 31, 2013		

Channel 52

	Freq	Level	Limit Line	Over Limit	Read Level	CableAntenna Loss	Antenna Factor	Preamp Factor	Remark	A/Pos	T/Pos	PoI/Phase
	MHz	dBuV/m	dBuV/m	dB	dBuV	dB	dB/m	dB		cm	deg	
1	5119.40	40.39	54.00	-13.61	3.35	3.43	33.61	0.00	Average	113	336	VERTICAL
2	5135.60	52.11	74.00	-21.89	15.04	3.43	33.64	0.00	Peak	113	336	VERTICAL
3	5264.80	118.02			80.68	3.46	33.88	0.00	Peak	113	336	VERTICAL
4	5265.40	107.79			70.45	3.46	33.88	0.00	Average	113	336	VERTICAL
5	5354.20	56.80	74.00	-17.20	19.28	3.49	34.03	0.00	Peak	113	336	VERTICAL
6	5400.40	45.63	54.00	-8.37	8.00	3.51	34.12	0.00	Average	113	336	VERTICAL

Item 3, 4 are the fundamental frequency at 5260 MHz.

Channel 60

	Freq	Level	Limit Line	Over Limit	Read Level	CableAntenna Loss	Antenna Factor	Preamp Factor	Remark	A/Pos	T/Pos	PoI/Phase
	MHz	dBuV/m	dBuV/m	dB	dBuV	dB	dB/m	dB		cm	deg	
1	5292.80	117.43			80.05	3.47	33.91	0.00	Peak	111	345	VERTICAL
2	5293.60	106.84			69.46	3.47	33.91	0.00	Average	111	345	VERTICAL
3	5350.00	53.86	54.00	-0.14	16.34	3.49	34.03	0.00	Average	111	345	VERTICAL
4	5352.40	72.07	74.00	-1.93	34.55	3.49	34.03	0.00	Peak	111	345	VERTICAL

Item 1, 2 are the fundamental frequency at 5300 MHz.

Channel 64

	Freq	Level	Limit Line	Over Limit	Read Level	CableAntenna Loss	Antenna Factor	Preamp Factor	Remark	A/Pos	T/Pos	PoI/Phase
	MHz	dBuV/m	dBuV/m	dB	dBuV	dB	dB/m	dB		cm	deg	
1	5324.00	114.96			77.50	3.49	33.97	0.00	Peak	100	319	VERTICAL
2	5325.20	104.83			67.37	3.49	33.97	0.00	Average	100	319	VERTICAL
3	5350.00	53.31	54.00	-0.69	15.79	3.49	34.03	0.00	Average	100	319	VERTICAL
4	5350.40	69.98	74.00	-4.02	32.46	3.49	34.03	0.00	Peak	100	319	VERTICAL

Item 1, 2 are the fundamental frequency at 5320 MHz.



Temperature	25.6°C	Humidity	56%
Test Engineer	Andre Tak	Configurations	IEEE 802.11n MCS0 20MHz Ch 100, 140 / Chain 1+ Chain 2 (2TX)
Test Date	Jan. 31, 2013		

Channel 100

	Freq	Level	Limit Line	Over Limit	Read Level	Cable Loss	Antenna Factor	Preamp Factor	Remark	A/Pos	T/Pos	PoI/Phase
	MHz	dBuV/m	dBuV/m	dB	dBuV	dB	dB/m	dB		cm	deg	
1	5452.40	42.59	54.00	-11.41	4.86	3.52	34.21	0.00	Average	122	196	VERTICAL
2	5453.40	60.55	74.00	-13.45	22.82	3.52	34.21	0.00	Peak	122	196	VERTICAL
3	5470.00	53.40	54.00	-0.60	15.64	3.52	34.24	0.00	Average	122	196	VERTICAL
4	5470.00	72.07	74.00	-1.93	34.31	3.52	34.24	0.00	Peak	122	196	VERTICAL
5	5505.00	114.48			76.66	3.54	34.28	0.00	Peak	122	196	VERTICAL
6	5506.20	104.08			66.26	3.54	34.28	0.00	Average	122	196	VERTICAL

Item 5, 6 are the fundamental frequency at 5500 MHz.

Channel 140

	Freq	Level	Limit Line	Over Limit	Read Level	Cable Loss	Antenna Factor	Preamp Factor	Remark	A/Pos	T/Pos	PoI/Phase
	MHz	dBuV/m	dBuV/m	dB	dBuV	dB	dB/m	dB		cm	deg	
1	5702.40	102.30			64.37	3.59	34.34	0.00	Average	104	8	VERTICAL
2	5702.80	112.52			74.59	3.59	34.34	0.00	Peak	104	8	VERTICAL
3	5725.00	53.78	54.00	-0.22	15.84	3.60	34.34	0.00	Average	104	8	VERTICAL
4	5725.40	72.67	74.00	-1.33	34.73	3.60	34.34	0.00	Peak	104	8	VERTICAL

Item 1, 2 are the fundamental frequency at 5700 MHz.



Temperature	25.6°C	Humidity	56%
Test Engineer	Andre Tak	Configurations	IEEE 802.11n MCS0 40MHz Ch 38, 46 / Chain 1+ Chain 2 (2TX)
Test Date	Jan. 31, 2013		

Channel 38

	Freq	Level	Limit	Over	Read	CableAntenna	Preamp	Remark	A/Pos	T/Pos	PoI/Phase
	MHz	dBuV/m	dBuV/m	dB	dBuV	dB	dB/m	dB	cm	deg	
1	5150.00	53.93	54.00	-0.07	16.83	3.43	33.67	0.00 Average	143	345	VERTICAL
2	5150.00	68.95	74.00	-5.05	31.85	3.43	33.67	0.00 Peak	143	345	VERTICAL
3	5192.00	107.97			70.80	3.44	33.73	0.00 Peak	143	345	VERTICAL
4	5193.20	97.69			60.52	3.44	33.73	0.00 Average	143	345	VERTICAL

Item 3, 4 are the fundamental frequency at 5190 MHz.

Channel 46

	Freq	Level	Limit	Over	Read	CableAntenna	Preamp	Remark	A/Pos	T/Pos	PoI/Phase
	MHz	dBuV/m	dBuV/m	dB	dBuV	dB	dB/m	dB	cm	deg	
1	5150.00	53.80	54.00	-0.20	16.70	3.43	33.67	0.00 Average	127	17	VERTICAL
2	5150.00	68.84	74.00	-5.16	31.74	3.43	33.67	0.00 Peak	127	17	VERTICAL
3	5232.00	104.07			66.79	3.46	33.82	0.00 Average	127	17	VERTICAL
4	5232.00	114.32			77.04	3.46	33.82	0.00 Peak	127	17	VERTICAL

Item 3, 4 are the fundamental frequency at 5230 MHz.

Temperature	25.6°C	Humidity	56%
Test Engineer	Andre Tak	Configurations	IEEE 802.11n MCS0 40MHz Ch 54, 62 / Chain 1+ Chain 2 (2TX)
Test Date	Jan. 31, 2013		

Channel 54

	Freq	Level	Limit	Over	Read	CableAntenna	Preamp	Remark	A/Pos	T/Pos	PoI/Phase
	MHz	dBuV/m	dBuV/m	dB	dBuV	dB	dB/m	dB	cm	deg	
1	5138.00	40.31	54.00	-13.69	3.24	3.43	33.64	0.00 Average	116	201	VERTICAL
2	5145.20	53.53	74.00	-20.47	16.43	3.43	33.67	0.00 Peak	116	201	VERTICAL
3	5280.20	104.24			66.86	3.47	33.91	0.00 Average	116	201	VERTICAL
4	5282.00	114.68			77.30	3.47	33.91	0.00 Peak	116	201	VERTICAL
5	5358.40	53.51	54.00	-0.49	15.99	3.49	34.03	0.00 Average	116	201	VERTICAL
6	5359.60	72.18	74.00	-1.82	34.66	3.49	34.03	0.00 Peak	116	201	VERTICAL

Item 3, 4 are the fundamental frequency at 5270 MHz.

Channel 62

	Freq	Level	Limit	Over	Read	CableAntenna	Preamp	Remark	A/Pos	T/Pos	PoI/Phase
	MHz	dBuV/m	dBuV/m	dB	dBuV	dB	dB/m	dB	cm	deg	
1	5308.80	95.45			58.03	3.48	33.94	0.00 Average	129	203	VERTICAL
2	5327.20	106.77			69.31	3.49	33.97	0.00 Peak	129	203	VERTICAL
3	5350.00	53.83	54.00	-0.17	16.31	3.49	34.03	0.00 Average	129	203	VERTICAL
4	5350.80	72.95	74.00	-1.05	35.43	3.49	34.03	0.00 Peak	129	203	VERTICAL

Item 1, 2 are the fundamental frequency at 5310 MHz.

Temperature	25.6°C	Humidity	56%
Test Engineer	Andre Tak	Configurations	IEEE 802.11n MCS0 40MHz Ch 102, 110, 134 / Chain 1+ Chain 2 (2TX)
Test Date	Jan. 31, 2013		

Channel 102

	Freq	Level	Limit Line	Over Limit	Read Level	Cable Loss	Antenna Factor	Preamp Factor	Remark	A/Pos	T/Pos	Pol/Phase
	MHz	dBuV/m	dBuV/m	dB	dBuV	dB	dB/m	dB		cm	deg	
1	5460.00	49.93	54.00	-4.07	12.20	3.52	34.21	0.00	Average	183	212	VERTICAL
2	5460.00	64.02	74.00	-9.98	26.29	3.52	34.21	0.00	Peak	183	212	VERTICAL
3	5465.20	53.52	54.00	-0.48	15.79	3.52	34.21	0.00	Average	183	212	VERTICAL
4	5465.60	70.14	74.00	-3.86	32.41	3.52	34.21	0.00	Peak	183	212	VERTICAL
5	5502.40	108.82			71.00	3.54	34.28	0.00	Average	183	212	VERTICAL
6	5502.80	97.81			59.99	3.54	34.28	0.00	Average	183	212	VERTICAL

Item 4, 5 are the fundamental frequency at 5510MHz.

Channel 110

	Freq	Level	Limit Line	Over Limit	Read Level	Cable Loss	Antenna Factor	Preamp Factor	Remark	A/Pos	T/Pos	Pol/Phase
	MHz	dBuV/m	dBuV/m	dB	dBuV	dB	dB/m	dB		cm	deg	
1	5451.20	63.58	74.00	-10.42	25.85	3.52	34.21	0.00	Peak	184	204	VERTICAL
2	5453.60	46.48	54.00	-7.52	8.75	3.52	34.21	0.00	Average	184	204	VERTICAL
3	5468.00	70.30	74.00	-3.70	32.54	3.52	34.24	0.00	Peak	184	204	VERTICAL
4	5468.40	53.49	54.00	-0.51	15.73	3.52	34.24	0.00	Average	184	204	VERTICAL
5	5547.60	104.06			66.20	3.55	34.31	0.00	Average	184	204	VERTICAL
6	5548.40	114.33			76.47	3.55	34.31	0.00	Peak	184	204	VERTICAL

Item 4, 5 are the fundamental frequency at 5550 MHz.

Channel 134

	Freq	Level	Limit Line	Over Limit	Read Level	Cable Loss	Antenna Factor	Preamp Factor	Remark	A/Pos	T/Pos	Pol/Phase
	MHz	dBuV/m	dBuV/m	dB	dBuV	dB	dB/m	dB		cm	deg	
1	5662.80	101.50			63.58	3.59	34.33	0.00	Average	103	15	VERTICAL
2	5664.00	111.32			73.40	3.59	34.33	0.00	Peak	103	15	VERTICAL
3	5725.00	53.61	54.00	-0.39	15.67	3.60	34.34	0.00	Average	103	15	VERTICAL
4	5725.40	69.30	74.00	-4.70	31.36	3.60	34.34	0.00	Peak	103	15	VERTICAL

Item 1, 2 are the fundamental frequency at 5670 MHz.

Note:

Emission level (dBuV/m) = 20 log Emission level (uV/m)

Corrected Reading: Antenna Factor + Cable Loss + Read Level - Preamp Factor = Level

Temperature	25.6°C	Humidity	56%
Test Engineer	Andre Tak	Configurations	IEEE 802.11a Ch 36, 40, 48 / Chain 1+ Chain 2 (2TX)
Test Date	Jan. 31, 2013		

Channel 36

	Freq	Level	Limit Line	Over Limit	Read Level	Cable Loss	Antenna Factor	Preamp Factor	Remark	A/Pos	T/Pos	Pol/Phase
	MHz	dBuV/m	dBuV/m	dB	dBuV	dB	dB/m	dB		cm	deg	
1	5150.00	53.19	54.00	-0.81	16.09	3.43	33.67	0.00	Average	115	34	VERTICAL
2	5150.00	69.00	74.00	-5.00	31.90	3.43	33.67	0.00	Peak	115	34	VERTICAL
3	5176.00	104.81			67.67	3.44	33.70	0.00	Average	115	34	VERTICAL
4	5176.40	114.68			77.54	3.44	33.70	0.00	Peak	115	34	VERTICAL

Item 3, 4 are the fundamental frequency at 5180 MHz.

Channel 40

	Freq	Level	Limit Line	Over Limit	Read Level	Cable Loss	Antenna Factor	Preamp Factor	Remark	A/Pos	T/Pos	Pol/Phase
	MHz	dBuV/m	dBuV/m	dB	dBuV	dB	dB/m	dB		cm	deg	
1	5148.80	72.04	74.00	-1.96	34.94	3.43	33.67	0.00	Peak	100	37	VERTICAL
2	5149.20	53.73	54.00	-0.27	16.63	3.43	33.67	0.00	Average	100	37	VERTICAL
3	5199.20	116.73			79.52	3.45	33.76	0.00	Peak	100	37	VERTICAL
4	5203.60	106.69			69.48	3.45	33.76	0.00	Average	100	37	VERTICAL

Item 3, 4 are the fundamental frequency at 5200 MHz.

Channel 48

	Freq	Level	Limit Line	Over Limit	Read Level	Cable Loss	Antenna Factor	Preamp Factor	Remark	A/Pos	T/Pos	Pol/Phase
	MHz	dBuV/m	dBuV/m	dB	dBuV	dB	dB/m	dB		cm	deg	
1	5147.00	55.11	74.00	-18.89	18.01	3.43	33.67	0.00	Peak	128	167	VERTICAL
2	5150.00	40.05	54.00	-13.95	2.95	3.43	33.67	0.00	Average	128	167	VERTICAL
3	5244.80	118.64			81.36	3.46	33.82	0.00	Peak	128	167	VERTICAL
4	5245.40	108.36			71.08	3.46	33.82	0.00	Average	128	167	VERTICAL
5	5363.20	41.86	54.00	-12.14	4.34	3.49	34.03	0.00	Average	128	167	VERTICAL
6	5363.80	54.10	74.00	-19.90	16.58	3.49	34.03	0.00	Peak	128	167	VERTICAL

Item 3, 4 are the fundamental frequency at 5240 MHz.

Temperature	25.6°C	Humidity	56%
Test Engineer	Andre Tak	Configurations	IEEE 802.11a Ch 52, 60, 64 / Chain 1+ Chain 2 (2TX)
Test Date	Jan. 31, 2013		

Channel 52

	Freq	Level	Limit Line	Over Limit	Read Level	Cable Loss	Antenna Factor	Preamp Factor	Remark	A/Pos	T/Pos	Pol/Phase
	MHz	dBuV/m	dBuV/m	dB	dBuV	dB	dB/m	dB		cm	deg	
1	5119.40	42.65	54.00	-11.35	5.61	3.43	33.61	0.00	Average	128	335	VERTICAL
2	5135.60	54.11	74.00	-19.89	17.04	3.43	33.64	0.00	Peak	128	335	VERTICAL
3	5264.80	108.82			71.48	3.46	33.88	0.00	Average	128	335	VERTICAL
4	5264.80	119.98			82.64	3.46	33.88	0.00	Peak	128	335	VERTICAL
5	5356.00	56.92	74.00	-17.08	19.40	3.49	34.03	0.00	Peak	128	335	VERTICAL
6	5400.40	44.19	54.00	-9.81	6.56	3.51	34.12	0.00	Average	128	335	VERTICAL

Item 3, 4 are the fundamental frequency at 5260 MHz.

Channel 60

	Freq	Level	Limit Line	Over Limit	Read Level	Cable Loss	Antenna Factor	Preamp Factor	Remark	A/Pos	T/Pos	Pol/Phase
	MHz	dBuV/m	dBuV/m	dB	dBuV	dB	dB/m	dB		cm	deg	
1	5306.40	107.79			70.37	3.48	33.94	0.00	Average	124	342	VERTICAL
2	5306.40	117.92			80.50	3.48	33.94	0.00	Peak	124	342	VERTICAL
3	5350.80	72.73	74.00	-1.27	35.21	3.49	34.03	0.00	Peak	124	342	VERTICAL
4	5351.60	53.34	54.00	-0.66	15.82	3.49	34.03	0.00	Average	124	342	VERTICAL

Item 1, 2 are the fundamental frequency at 5300 MHz.

Channel 64

	Freq	Level	Limit Line	Over Limit	Read Level	Cable Loss	Antenna Factor	Preamp Factor	Remark	A/Pos	T/Pos	Pol/Phase
	MHz	dBuV/m	dBuV/m	dB	dBuV	dB	dB/m	dB		cm	deg	
1	5326.00	104.91			67.45	3.49	33.97	0.00	Average	111	41	VERTICAL
2	5326.00	115.31			77.85	3.49	33.97	0.00	Peak	111	41	VERTICAL
3	5350.20	70.44	74.00	-3.56	32.92	3.49	34.03	0.00	Peak	111	41	VERTICAL
4	5350.80	53.22	54.00	-0.78	15.70	3.49	34.03	0.00	Average	111	41	VERTICAL

Item 1, 2 are the fundamental frequency at 5320 MHz.



Temperature	25.6°C	Humidity	56%
Test Engineer	Andre Tak	Configurations	IEEE 802.11a Ch 100, 140 / Chain 1+ Chain 2 (2TX)
Test Date	Jan. 31, 2013		

Channel 100

	Freq	Level	Limit	Over	Read	Cable	Antenna	Preamp	Remark	A/Pos	T/Pos	Pol/Phase
	MHz	dBuV/m	dBuV/m	dB	dBuV	dB	dB/m	dB		cm	deg	
1	5460.00	45.16	54.00	-8.84	7.43	3.52	34.21	0.00	Average	125	10	VERTICAL
2	5460.00	62.95	74.00	-11.05	25.22	3.52	34.21	0.00	Peak	125	10	VERTICAL
3	5470.00	53.31	54.00	-0.69	15.55	3.52	34.24	0.00	Average	125	10	VERTICAL
4	5470.00	69.37	74.00	-4.63	31.61	3.52	34.24	0.00	Peak	125	10	VERTICAL
5	5496.00	104.48			66.69	3.53	34.26	0.00	Average	125	10	VERTICAL
6	5505.60	114.16			76.34	3.54	34.28	0.00	Peak	125	10	VERTICAL

Item 5, 6 are the fundamental frequency at 5500 MHz.

Channel 140

	Freq	Level	Limit	Over	Read	Cable	Antenna	Preamp	Remark	A/Pos	T/Pos	Pol/Phase
	MHz	dBuV/m	dBuV/m	dB	dBuV	dB	dB/m	dB		cm	deg	
1	5697.20	102.55			64.62	3.59	34.34	0.00	Average	100	19	VERTICAL
2	5697.60	111.93			74.00	3.59	34.34	0.00	Peak	100	19	VERTICAL
3	5726.60	53.71	54.00	-0.29	15.77	3.60	34.34	0.00	Average	100	19	VERTICAL
4	5727.40	71.75	74.00	-2.25	33.81	3.60	34.34	0.00	Peak	100	19	VERTICAL

Item 1, 2 are the fundamental frequency at 5700 MHz.

Note:

Emission level (dBuV/m) = 20 log Emission level (uV/m)

Corrected Reading: Antenna Factor + Cable Loss + Read Level - Preamp Factor = Level

4.8. Frequency Stability Measurement

4.8.1. Limit

Manufacturers of U-NII devices are responsible for ensuring frequency stability such that an emissions is maintained within the band of operation under all conditions of normal operation as specified in the user's manual or $\pm 20\text{ppm}$ (IEEE 802.11nspecification).

4.8.2. Measuring Instruments and Setting

Please refer to section 5 of equipments list in this report. The following table is the setting of the spectrum analyzer.

Spectrum Parameter	Setting
Attenuation	Auto
Span Frequency	Entire absence of modulation emissions bandwidth
RB	10 kHz
VB	10 kHz
Sweep Time	Auto

4.8.3. Test Procedures

1. The transmitter output (antenna port) was connected to the spectrum analyzer.
2. EUT have transmitted absence of modulation signal and fixed channelize.
3. Set the spectrum analyzer span to view the entire absence of modulation emissions bandwidth.
4. Set RBW = 10 kHz, VBW = 10 kHz with peak detector and maxhold settings.
5. f_c is declaring of channel frequency. Then the frequency error formula is $(f_c - f)/f_c \times 10^6$ ppm and the limit is less than $\pm 20\text{ppm}$ (IEEE 802.11nspecification).
6. The test extreme voltage is to change the primary supply voltage from 85 to 115 percent of the nominal value
7. Extreme temperature rule is $-30^\circ\text{C} \sim 50^\circ\text{C}$.

4.8.4. Test Setup Layout

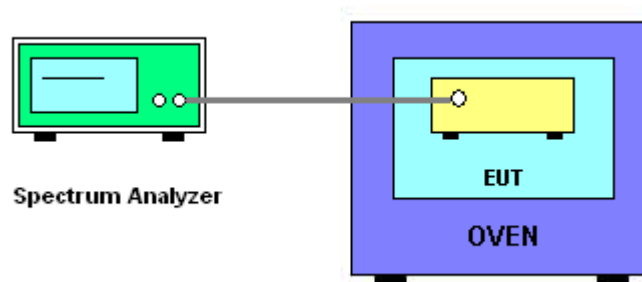

4.8.5. Test Deviation

There is no deviation with the original standard.

4.8.6. EUT Operation during Test

The EUT was programmed to be in continuously un-modulation transmitting mode.

4.8.7. Test Result of Frequency Stability

Voltage vs. Frequency Stability

Voltage	Measurement Frequency (MHz)	
	5200	5300
(V)		
126.50	5199.9856	5299.9844
110.00	5199.9808	5299.9862
93.50	5199.9784	5299.9802
Max. Deviation (MHz)	0.021600	0.019800
Max. Deviation (ppm)	4.15	3.74

Temperature vs. Frequency Stability

Temperature	Measurement Frequency (MHz)	
	5200	5300
(°C)		
-30	5199.9842	5299.9872
-20	5199.9802	5299.9764
-10	5199.9790	5299.9782
0	5199.9754	5299.9788
10	5199.9748	5299.9798
20	5199.9760	5299.9792
30	5199.9724	5299.9786
40	5199.9732	5299.9798
50	5199.9752	5299.9780
Max. Deviation (MHz)	0.027600	0.023600
Max. Deviation (ppm)	5.31	4.4528

4.9. Antenna Requirements

4.9.1. Limit

Except for special regulations, the Low-power Radio-frequency Devices must not be equipped with any jacket for installing an antenna with extension cable. An intentional radiator shall be designed to ensure that no antenna other than that furnished by the responsible party shall be used with the device. The use of a permanently attached antenna or of an antenna that uses a unique coupling to the intentional radiator shall be considered sufficient to comply with the provisions of this Section. The manufacturer may design the unit so that the user can replace a broken antenna, but the use of a standard antenna jack or electrical connector is prohibited. Further, this requirement does not apply to intentional radiators that must be professionally installed.

4.9.2. Antenna Connector Construction

Please refer to section 3.3 in this test report; antenna connector complied with the requirements.

5. LIST OF MEASURING EQUIPMENTS

Instrument	Manufacturer	Model No.	Serial No.	Characteristics	Calibration Date	Remark
EMI Test Receiver	R&S	ESCS 30	100377	9kHz ~ 2.75GHz	Oct. 23, 2012	Conduction (CO01-CB)
LISN	F.C.C.	FCC-LISN-50-16-2	04083	150kHz ~ 100MHz	Nov.26, 2012	Conduction (CO01-CB)
V- LISN	Schwarzbeck	NSLK 8127	8127-478	9kHz ~ 30MHz	Jun. 22, 2012	Conduction (CO01-CB)
Coupling Decoupling Network	TESEQ	ST08	24348	150kHz ~ 230MHz	Dec. 03, 2012	Conduction (CO01-CB)
COND Cable	Woken	Cable	01	0.15MHz-30MHz	Dec. 4, 2012	Conduction (CO01-CB)
Software	Audix	E3	5.410e	-	-	Conduction (CO01-CB)
BILOG ANTENNA	Schaffner	CBL6112D	22021	20MHz ~ 2GHz	Jan. 11, 2012	Radiation (03CH01-CB)
Loop Antenna	Teseq	HLA 6120	24155	9 kHz - 30 MHz	Nov. 05, 2012*	Radiation (03CH01-CB)
forHorn Antenna	EMCO	3115	00075790	750MHz~18GHz	Nov. 27, 2012	Radiation (03CH01-CB)
Horn Antenna	SCHWARZBEAK	BBHA 9170	BBHA9170252	15GHz ~ 40GHz	Nov. 23, 2012	Radiation (03CH01-CB)
Pre-Amplifier	Agilent	8447D	2944A10991	0.1MHz ~ 1.3GHz	Nov. 27, 2012	Radiation (03CH01-CB)
Pre-Amplifier	Agilent	8449B	3008A02310	1GHz ~ 26.5GHz	Nov. 23, 2012	Radiation (03CH01-CB)
Pre-Amplifier	WM	TF-130N-R1	923365	26.5GHz ~ 40GHz	Jul. 31, 2012	Radiation (03CH01-CB)
Spectrum analyzer	R&S	FSP40	100056	9KHz-40GHz	Nov. 16, 2012	Radiation (03CH01-CB)
EMI Test Receiver	R&S	ESCS 30	100355	9KHz ~ 2.75GHz	Mar. 20, 2012	Radiation (03CH01-CB)
Turn Table	INN CO	CO 2000	N/A	0 ~ 360 degree	N.C.R	Radiation (03CH01-CB)
Antenna Mast	INN CO	CO2000	N/A	1 m - 4 m	N.C.R	Radiation (03CH01-CB)
RF Cable-low	Woken	Low Cable-1	N/A	30 MHz - 1 GHz	Nov. 18, 2012	Radiation (03CH01-CB)
RF Cable-high	Woken	High Cable-1	N/A	1 GHz ~ 26.5 GHz	Nov. 18, 2012	Radiation (03CH01-CB)
RF Cable-high	Woken	High Cable-2	N/A	1 GHz ~ 26.5 GHz	Nov. 18, 2012	Radiation (03CH01-CB)
RF Cable-high	Woken	High Cable-3	N/A	1 GHz - 40 GHz	Nov. 18, 2012	Radiation (03CH01-CB)
RF Cable-high	Woken	High Cable-4	N/A	1 GHz - 40 GHz	Nov. 18, 2012	Radiation (03CH01-CB)
Signal analyzer	R&S	FSV40	100979	9KHz-40GHz	Oct. 08, 2012	Conducted (TH01-CB)

Instrument	Manufacturer	Model No.	Serial No.	Characteristics	Calibration Date	Remark
Temp. and Humidity Chamber	Ten Billion	TTH-D3SP	TBN-931011	-30~100 degree	Jun. 05, 2012	Conducted (TH01-CB)
RF Power Divider	Woken	2 Way	0120A02056002D	2GHz ~ 18GHz	Nov. 18, 2012	Conducted (TH01-CB)
RF Power Divider	Woken	3 Way	MDC2366	2GHz ~ 18GHz	Nov. 18, 2012	Conducted (TH01-CB)
RF Power Divider	Woken	4 Way	0120A04056002D	2GHz ~ 18GHz	Nov. 18, 2012	Conducted (TH01-CB)
RF Cable-high	Woken	High Cable-7	-	1 GHz ~ 26.5 GHz	Nov. 19, 2012	Conducted (TH01-CB)
RF Cable-high	Woken	High Cable-8	-	1 GHz ~ 26.5 GHz	Nov. 19, 2012	Conducted (TH01-CB)
RF Cable-high	Woken	High Cable-9	-	1 GHz ~ 26.5 GHz	Nov. 19, 2012	Conducted (TH01-CB)
RF Cable-high	Woken	High Cable-10	-	1 GHz ~ 26.5 GHz	Nov. 19, 2012	Conducted (TH01-CB)
RF Cable-high	Woken	High Cable-11	-	1 GHz ~ 26.5 GHz	Nov. 19, 2012	Conducted (TH01-CB)
Power Sensor	Anritsu	MA2411B	0917223	300MHz~40GHz	Nov. 28, 2012	Conducted (TH01-CB)
Power Meter	Anritsu	ML2495A	1035008	300MHz~40GHz	Nov. 27, 2012	Conducted (TH01-CB)

Note: Calibration Interval of instruments listed above is one year.

“*” Calibration Interval of instruments listed above is two years.

N.C.R. means Non-Calibration required.

6. TEST LOCATION

SHIJR	ADD : 6Fl., No. 106, Sec. 1, Shintai 5th Rd., Shijr City, Taipei, Taiwan 221, R.O.C. TEL : 886-2-2696-2468 FAX : 886-2-2696-2255
HWA YA	ADD : No. 52, Hwa Ya 1st Rd., Kwei-Shan Hsiang, Tao Yuan Hsien, Taiwan, R.O.C. TEL : 886-3-327-3456 FAX : 886-3-318-0055
LINKOU	ADD : No. 30-2, Dingfu Tsuen, Linkou Shiang, Taipei, Taiwan 244, R.O.C TEL : 886-2-2601-1640 FAX : 886-2-2601-1695
DUNGHU	ADD : No. 3, Lane 238, Kangle St., Neihu Chiu, Taipei, Taiwan 114, R.O.C. TEL : 886-2-2631-4739 FAX : 886-2-2631-9740
JUNGHE	ADD : 7Fl., No. 758, Jungjeng Rd., Junghe City, Taipei, Taiwan 235, R.O.C. TEL : 886-2-8227-2020 FAX : 886-2-8227-2626
NEIHU	ADD : 4Fl., No. 339, Hsin Hu 2 nd Rd., Taipei 114, Taiwan, R.O.C. TEL : 886-2-2794-8886 FAX : 886-2-2794-9777
JHUBEI	ADD : No.8, Lane 724, Bo-ai St., Jhubei City, HsinChu County 302, Taiwan, R.O.C. TEL : 886-3-656-9065 FAX : 886-3-656-9085