



SPORTON International Inc.

No. 52, Hwa Ya 1st Rd., Kwei-Shan Hsiang, TaoYuan Hsien, Taiwan, R.O.C.
Ph: 886-3-327-3456 / FAX: 886-3-327-0973 / www.sporton.com.tw

FCC RADIO TEST REPORT

Applicant's company	Teldat S.A.
Applicant Address	Isaac Newton, 10, Parque Tecnológico de Madrid, 28760 – Tres Cantos, Madrid, Spain
FCC ID	YUAWMCND03TD
Manufacturer's company	Alpha Networks Inc.
Manufacturer Address	No.8 Li-shing 7th Rd., Science-based Industrial Park, Hsinchu, Taiwan, R.O.C.
Manufacturer's company	Alpha Networks (Dongguan) Co., Ltd.
Manufacturer Address	Xin An District, Chang An Town, DongGuan City, GuangDong Province, China

Product Name	WiFi module
Brand Name	Teldat
Model Name	WMCND03TD
Test Rule Part(s)	47 CFR FCC Part 15 Subpart C § 15.247
Test Freq. Range	2400 ~ 2483.5MHz / 5725 ~ 5850MHz
Received Date	Jan. 24, 2013
Final Test Date	Feb. 26, 2013
Submission Type	Original Equipment



Statement

Test result included is only for the IEEE 802.11n, IEEE 802.11b/g part and IEEE 802.11a (5725 - 5850MHz) of the product.

The test result in this report refers exclusively to the presented test model / sample.

Without written approval of SPORTON International Inc., the test report shall not be reproduced except in full.

The measurements and test results shown in this test report were made in accordance with the procedures and found in compliance with the limit given in **ANSI C63.10-2009, 47 CFR FCC Part 15 Subpart C, KDB 558074 D01 v02 and KDB 662911 D01 v01r02.**

The test equipment used to perform the test is calibrated and traceable to NML/ROC.





Table of Contents

1. CERTIFICATE OF COMPLIANCE	1
2. SUMMARY OF THE TEST RESULT	2
3. GENERAL INFORMATION	3
3.1. Product Details	3
3.2. Accessories	5
3.3. Table for Filed Antenna	6
3.4. Table for Carrier Frequencies	7
3.5. Table for Test Modes	8
3.6. Table for Testing Locations.....	10
3.7. Table for Supporting Units	10
3.8. Table for Parameters of Test Software Setting	11
3.9. Test Configurations.....	13
4. TEST RESULT	16
4.1. AC Power Line Conducted Emissions Measurement	16
4.2. Maximum Conducted Output Power Measurement.....	20
4.3. Power Spectral Density Measurement.....	23
4.4. 6dB Spectrum Bandwidth Measurement	32
4.5. Radiated Emissions Measurement.....	39
4.6. Emissions Measurement.....	65
4.7. Antenna Requirements	85
5. LIST OF MEASURING EQUIPMENTS	86
6. TEST LOCATION	88
APPENDIX A. TEST PHOTOS	A1 ~ A8
APPENDIX B. MAXIMUM PERMISSIBLE EXPOSURE	B1 ~ B3



History of This Test Report

REPORT NO.	VERSION	DESCRIPTION	ISSUED DATE
FR311203-01AA	Rev. 01	Initial issue of report	Mar. 28, 2013
FR311203-01AA	Rev. 02	Revised Applicant Address	Apr. 09, 2013



1. CERTIFICATE OF COMPLIANCE

Product Name : WiFi module
Brand Name : Teldat
Model Name : WMCND03TD
Applicant : Teldat S.A.
Test Rule Part(s) : 47 CFR FCC Part 15 Subpart C § 15.247

Sporton International as requested by the applicant to evaluate the EMC performance of the product sample received on Jan. 24, 2013 would like to declare that the tested sample has been evaluated and found to be in compliance with the tested rule parts. The data recorded as well as the test configuration specified is true and accurate for showing the sample's EMC nature.

A handwritten signature in blue ink that reads 'Sam Chen' is written over a horizontal line.

Sam Chen

SPORTON INTERNATIONAL INC.

2. SUMMARY OF THE TEST RESULT

Applied Standard: 47 CFR FCC Part 15 Subpart C				
Part	Rule Section	Description of Test	Result	Under Limit
4.1	15.207	AC Power Line Conducted Emissions	Complies	10.74 dB
4.2	15.247(b)(3)	Maximum Conducted Output Power	Complies	5.77 dB
4.3	15.247(e)	Power Spectral Density	Complies	8.12 dB
4.4	15.247(a)(2)	6dB Spectrum Bandwidth	Complies	-
4.5	15.247(d)	Radiated Emissions	Complies	0.12 dB
4.6	15.247(d)	Band Edge Emissions	Complies	0.28 dB
4.7	15.203	Antenna Requirements	Complies	-

Test Items	Uncertainty	Remark
AC Power Line Conducted Emissions	±2.3dB	Confidence levels of 95%
Maximum Conducted Output Power	±0.8dB	Confidence levels of 95%
Power Spectral Density	±0.5dB	Confidence levels of 95%
6dB Spectrum Bandwidth	±8.5×10 ⁻⁸	Confidence levels of 95%
Radiated Emissions (9kHz~30MHz)	±0.8dB	Confidence levels of 95%
Radiated Emissions (30MHz~1000MHz)	±1.9dB	Confidence levels of 95%
Radiated / Band Edge Emissions (1GHz~18GHz)	±1.9dB	Confidence levels of 95%
Radiated Emissions (18GHz~40GHz)	±1.9dB	Confidence levels of 95%
Temperature	±0.7°C	Confidence levels of 95%
Humidity	±3.2%	Confidence levels of 95%
DC / AC Power Source	±1.4%	Confidence levels of 95%

3. GENERAL INFORMATION

3.1. Product Details

IEEE 802.11n

Items	Description
Product Type	WLAN (2TX, 2RX)
Radio Type	Intentional Transceiver
Power Type	From Host System
Modulation	see the below table for IEEE 802.11n
Data Modulation	OFDM (BPSK / QPSK / 16QAM / 64QAM)
Data Rate (Mbps)	see the below table for IEEE 802.11n
Frequency Range	2400 ~ 2483.5MHz / 5725 ~ 5850MHz
Channel Number	For 2.4GHz Band: 11 for 20MHz bandwidth ; 7 for 40MHz bandwidth For 5GHz Band: 5 for 20MHz bandwidth ; 2 for 40MHz bandwidth
Channel Band Width (99%)	For 2.4GHz Band: MCS0 (20MHz): 18.00 MHz ; MCS0 (40MHz): 36.80 MHz For 5GHz Band: MCS0 (20MHz): 28.72 MHz ; MCS0 (40MHz): 63.84 MHz
Maximum Conducted Output Power	For 2.4GHz Band: MCS0 (20MHz): 18.73 dBm ; MCS0 (40MHz): 18.73 dBm For 5GHz Band: MCS0 (20MHz): 23.98 dBm ; MCS0 (40MHz): 24.08 dBm
Carrier Frequencies	Please refer to section 3.4
Antenna	Please refer to section 3.3

802.11a/b/g

Items	Description
Product Type	11b: WLAN (1TX, 2RX) 11a/g: WLAN (2TX, 2RX)
Radio Type	Intentional Transceiver
Power Type	From Host System
Modulation	DSSS for IEEE 802.11b ; OFDM for IEEE 802.11a/g
Data Modulation	DSSS (BPSK / QPSK / CCK) ; OFDM (BPSK / QPSK / 16QAM / 64QAM)
Data Rate (Mbps)	DSSS (1/ 2/ 5.5/11) ; OFDM (6/9/12/18/24/36/48/54)
Frequency Range	2400 ~ 2483.5MHz / 5725 ~ 5850MHz
Channel Number	11b/g: 11 ; 11a: 5
Channel Band Width (99%)	11b: 14.24MHz ; 11g: 16.72 MHz ; 11a: 29.92 MHz
Maximum Conducted Output Power	11b: 20.50 dBm ; 11g: 19.47 dBm ; 11a: 24.23 dBm
Carrier Frequencies	Please refer to section 3.4
Antenna	Please refer to section 3.3

Antenna & Band width

Antenna	Single (TX)		Two (TX)	
	20 MHz	40 MHz	20 MHz	40 MHz
IEEE 802.11a	X	X	V	X
IEEE 802.11b	V	X	X	X
IEEE 802.11g	X	X	V	X
IEEE 802.11n	X	X	V	V

IEEE 802.11n spec

MCS Index	Nss	Modulation	R	NBPS	NCBPS		NDBPS		Datarate(Mbps)			
					20MHz	40MHz	20MHz	40MHz	800nsGI		400nsGI	
									20MHz	40MHz	20MHz	40MHz
0	1	BPSK	1/2	1	52	108	26	54	6.5	13.5	7.200	15
1	1	QPSK	1/2	2	104	216	52	108	13.0	27.0	14.400	30
2	1	QPSK	3/4	2	104	216	78	162	19.5	40.5	21.700	45
3	1	16-QAM	1/2	4	208	432	104	216	26.0	54.0	28.900	60
4	1	16-QAM	3/4	4	208	432	156	324	39.0	81.0	43.300	90
5	1	64-QAM	2/3	6	312	648	208	432	52.0	108.0	57.800	120
6	1	64-QAM	3/4	6	312	648	234	486	58.5	121.5	65.000	135
7	1	64-QAM	5/6	6	312	648	260	540	65.0	135.0	72.200	150

Symbol	Explanation
NSS	Number of spatial streams
R	Code rate
NBPS	Number of coded bits per single carrier
NCBPS	Number of coded bits per symbol
NDBPS	Number of data bits per symbol
GI	guard interval

3.2. Accessories

N/A

3.3. Table for Filed Antenna

Chain	Brand	Model Name	Antenna Type	Connector	Gain (dBi)	Remark
1	MAG.LAYERS	EDA-8709-25GR2-A9	Omni-directional Antenna	I-PEX	2	TX / RX
2	MAG.LAYERS	EDA-8709-25GR2-A9	Omni-directional Antenna	I-PEX	2	TX / RX

Note: The EUT has two Chains.

For IEEE 802.11b mode (1TX/2RX):

Both Chain 1 and Chain 2 can be used as receiving chains.

Only Chain 1 can be use as transmitting chain.

For IEEE 802.11a/g/n mode (2TX/2RX):

Chain 1 and Chain 2 could transmit/receive simultaneously.

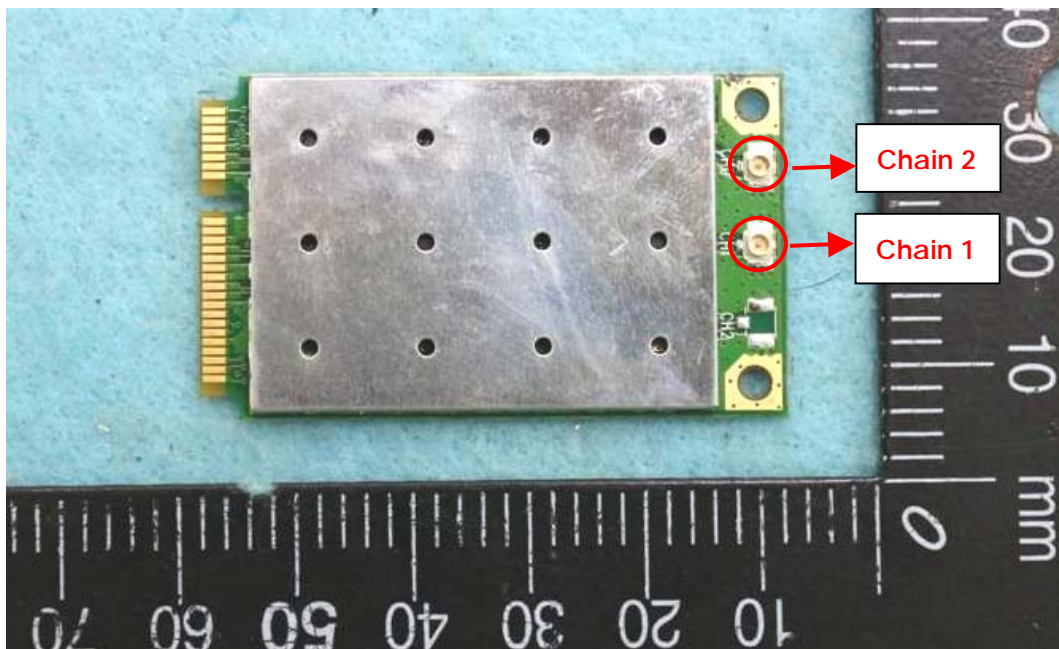

3.4. Table for Carrier Frequencies

For 2.4GHz Band:

For IEEE 802.11b/g, use Channel 1~Channel 11.

There are two bandwidth systems for IEEE 802.11n.

For both 20MHz bandwidth systems, use Channel 1~Channel 11.

For both 40MHz bandwidth systems, use Channel 3~Channel 9.

Frequency Band	Channel No.	Frequency	Channel No.	Frequency
2400~2483.5MHz	1	2412 MHz	7	2442 MHz
	2	2417 MHz	8	2447 MHz
	3	2422 MHz	9	2452 MHz
	4	2427 MHz	10	2457 MHz
	5	2432 MHz	11	2462 MHz
	6	2437 MHz	-	-

For 5GHz Band:

For IEEE 802.11a, use Channel 149, 153, 157, 161, 165.

There are two bandwidth systems for IEEE 802.11n.

For 20MHz bandwidth systems, use Channel 149, 153, 157, 161, 165.

For 40MHz bandwidth systems, use Channel 151, 159.

Frequency Band	Channel No.	Frequency	Channel No.	Frequency
5725~5850 MHz Band 4	149	5745 MHz	159	5795 MHz
	151	5755 MHz	161	5805 MHz
	153	5765 MHz	165	5825 MHz
	157	5785 MHz	-	-

3.5. Table for Test Modes

Preliminary tests were performed in different data rate to find the worst radiated emission. The data rate shown in the table below is the worst-case rate with respect to the specific test item. Investigation has been done on all the possible configurations for searching the worst cases. The following table is a list of the test modes shown in this test report.

For 2.4GHz Band

Test Items	Mode	Data Rate	Channel	Chain
AC Power Line Conducted Emissions	Normal Link	Auto	-	-
Maximum Conducted Output Power	MCS0/20MHz	6.5 Mbps	1/6/11	1+2
	MCS0/40MHz	13.5 Mbps	3/6/9	1+2
	11b/CCK	1 Mbps	1/6/11	1
	11g/BPSK	6 Mbps	1/6/11	1+2
Power Spectral Density	MCS0/20MHz	6.5 Mbps	1/6/11	1+2
	MCS0/40MHz	13.5 Mbps	3/6/9	1+2
	11b/CCK	1 Mbps	1/6/11	1
	11g/BPSK	6 Mbps	1/6/11	1+2
6dB Spectrum Bandwidth	MCS0/20MHz	6.5 Mbps	1/6/11	1+2
	MCS0/40MHz	13.5 Mbps	3/6/9	1+2
	11b/CCK	1 Mbps	1/6/11	1
	11g/BPSK	6 Mbps	1/6/11	1+2
Radiated Emissions Below 1GHz	Normal Link	Auto	-	-
Radiated Emissions Above 1GHz	MCS0/20MHz	6.5 Mbps	1/6/11	1+2
	MCS0/40MHz	13.5 Mbps	3/6/9	1+2
	11b/CCK	1 Mbps	1/6/11	1
	11g/BPSK	6 Mbps	1/6/11	1+2
Band Edge Emissions	MCS0/20MHz	6.5 Mbps	1/6/11	1+2
	MCS0/40MHz	13.5 Mbps	3/6/9	1+2
	11b/CCK	1 Mbps	1/6/11	1
	11g/BPSK	6 Mbps	1/6/11	1+2

For 5GHz Band

Test Items	Mode	Data Rate	Channel	Chain
AC Power Line Conducted Emissions	Normal Link	Auto	-	-
Maximum Conducted Output Power	MCS0/20MHz	6.5 Mbps	149/157/165	1+2
	MCS0/40MHz	13.5 Mbps	151/159	1+2
	11a/BPSK	6 Mbps	149/157/165	1+2
Power Spectral Density	MCS0/20MHz	6.5 Mbps	149/157/165	1+2
	MCS0/40MHz	13.5 Mbps	151/159	1+2
	11a/BPSK	6 Mbps	149/157/165	1+2
6dB Spectrum Bandwidth	MCS0/20MHz	6.5 Mbps	149/157/165	1+2
	MCS0/40MHz	13.5 Mbps	151/159	1+2
	11a/BPSK	6 Mbps	149/157/165	1+2
Radiated Emissions Below 1GHz	Normal Link	Auto	-	-
Radiated Emissions Above 1GHz	MCS0/20MHz	6.5 Mbps	149/157/165	1+2
	MCS0/40MHz	13.5 Mbps	151/159	1+2
	11a/BPSK	6 Mbps	149/157/165	1+2
Band Edge Emissions	MCS0/20MHz	6.5 Mbps	149/157/165	1+2
	MCS0/40MHz	13.5 Mbps	151/159	1+2
	11a/BPSK	6 Mbps	149/157/165	1+2

3.6. Table for Testing Locations

Test Site No.	Site Category	Location	FCC Reg. No.	IC File No.
03CH01-CB	SAC	Hsin Chu	262045	IC 4086D
CO01-CB	Conduction	Hsin Chu	262045	IC 4086D
TH01-CB	OVEN Room	Hsin Chu	-	-

Open Area Test Site (OATS); Semi Anechoic Chamber (SAC).

Please refer section 6 for Test Site Address.

3.7. Table for Supporting Units

For Conducted Emission test:

Support Unit	Brand	Model	FCC ID
Notebook	DELL	1200	E2K4965AGNM
Mouse	Logitech	M-U0026	DoC
Earphone	SHYARO CHI	MIC-04	N/A
Wireless AP	Planex	GW-AP54SGX	N/A

For Radiated Emission test:

Support Unit	Brand	Model	FCC ID
Notebook	DELL	E6220	N/A
Mouse	Logitech	M-U0026	DoC
Earphone	SHYARO CHI	MIC-04	N/A
Wireless AP	Planex	GW-AP54SGX	N/A

For Maximum Conducted Output Power, Power Spectral Density and 6dB Spectrum Bandwidth test:

Support Unit	Brand	Model	FCC ID
Notebook	DELL	M1330	E2KWM3945ABG

3.8. Table for Parameters of Test Software Setting

During testing, Channel & Power Controlling Software provided by the customer was used to control the operating channel as well as the output power level. The RF output power selection is for the setting of RF output power expected by the customer and is going to be fixed on the firmware of the final end product.

For 2.4GHz Band

Power Parameters of IEEE 802.11n MCS0 20MHz / Chain 1 + Chain 2 (2TX)

Test Software Version	ART2-GUI Version 2.3		
Frequency	2412 MHz	2437 MHz	2462 MHz
MCS0 20MHz	12.5	12.5	12.5

Power Parameters of IEEE 802.11n MCS0 40MHz / Chain 1 + Chain 2 (2TX)

Test Software Version	ART2-GUI Version 2.3		
Frequency	2422 MHz	2437 MHz	2452 MHz
MCS0 40MHz	11.5	12.5	10.5

Power Parameters of IEEE 802.11b / Chain 1 (1TX)

Test Software Version	ART2-GUI Version 2.3		
Frequency	2412 MHz	2437 MHz	2462 MHz
IEEE 802.11b	17.5	17.5	17.5

Power Parameters of IEEE 802.11g / Chain 1 + Chain 2 (2TX)

Test Software Version	ART2-GUI Version 2.3		
Frequency	2412 MHz	2437 MHz	2462 MHz
IEEE 802.11g	13	13	13

For 5GHz Band
Power Parameters of IEEE 802.11n MCS0 20MHz / Chain 1 + Chain 2 (2TX)

Test Software Version	ART2-GUI Version 2.3		
Frequency	5745 MHz	5785 MHz	5825 MHz
MCS0 20MHz	23	23	23

Power Parameters of IEEE 802.11n MCS0 40MHz / Chain 1 + Chain 2 (2TX)

Test Software Version	ART2-GUI Version 2.3	
Frequency	5755 MHz	5795 MHz
MCS0 40MHz	23	23

Power Parameters of IEEE 802.11a / Chain 1 + Chain 2 (2TX)

Test Software Version	ART2-GUI Version 2.3		
Frequency	5745 MHz	5785 MHz	5825 MHz
IEEE 802.11a	23	23	23

During the test, "ART2-GUI Version 2.3" under WIN XP was executed the test program to control the EUT continuously transmit RF signal.

3.9. Test Configurations

3.9.1. Radiation Emissions Test Configuration

Test Configuration: 30 MHz ~ 1 GHz

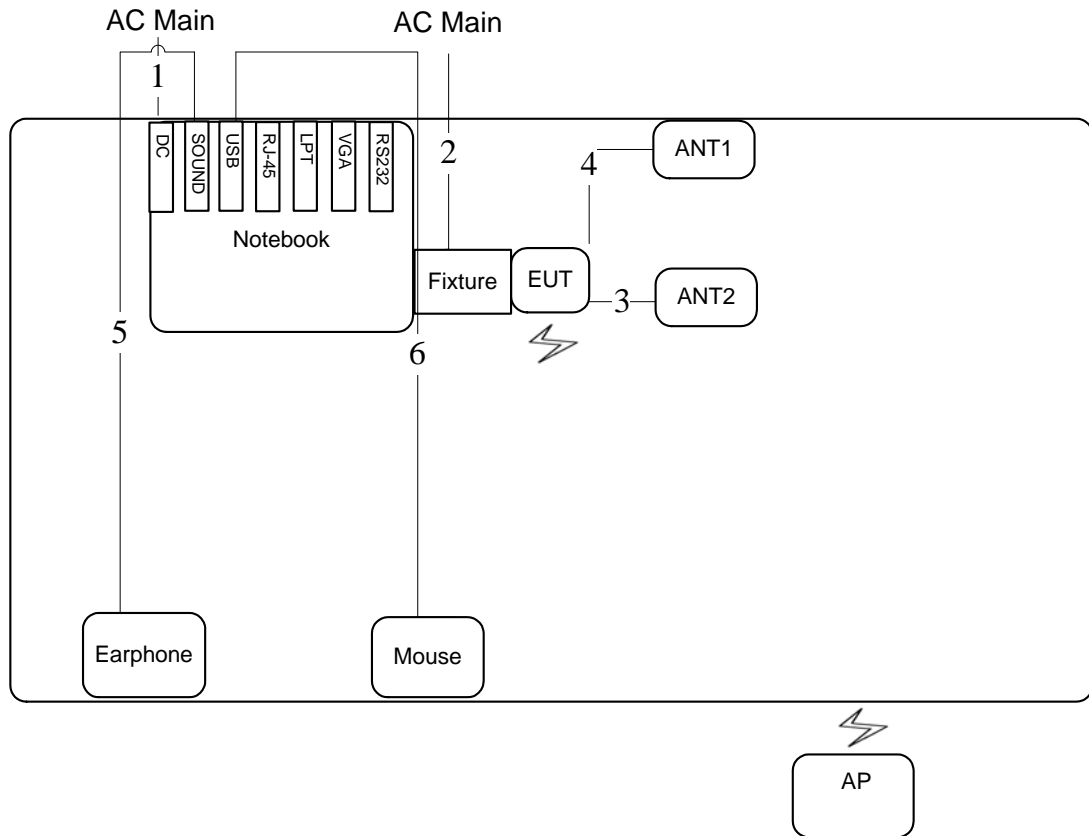

Item	Connection	Shield	Length
1	Power cable	No	1.8m
2	Power cable	No	1.5m
3	Antenna cable	Yes	0.1m
4	Antenna cable	Yes	0.1m
5	Audio cable	No	1.1m
6	USB cable	No	1.5m

Test Configuration: above 1 GHz

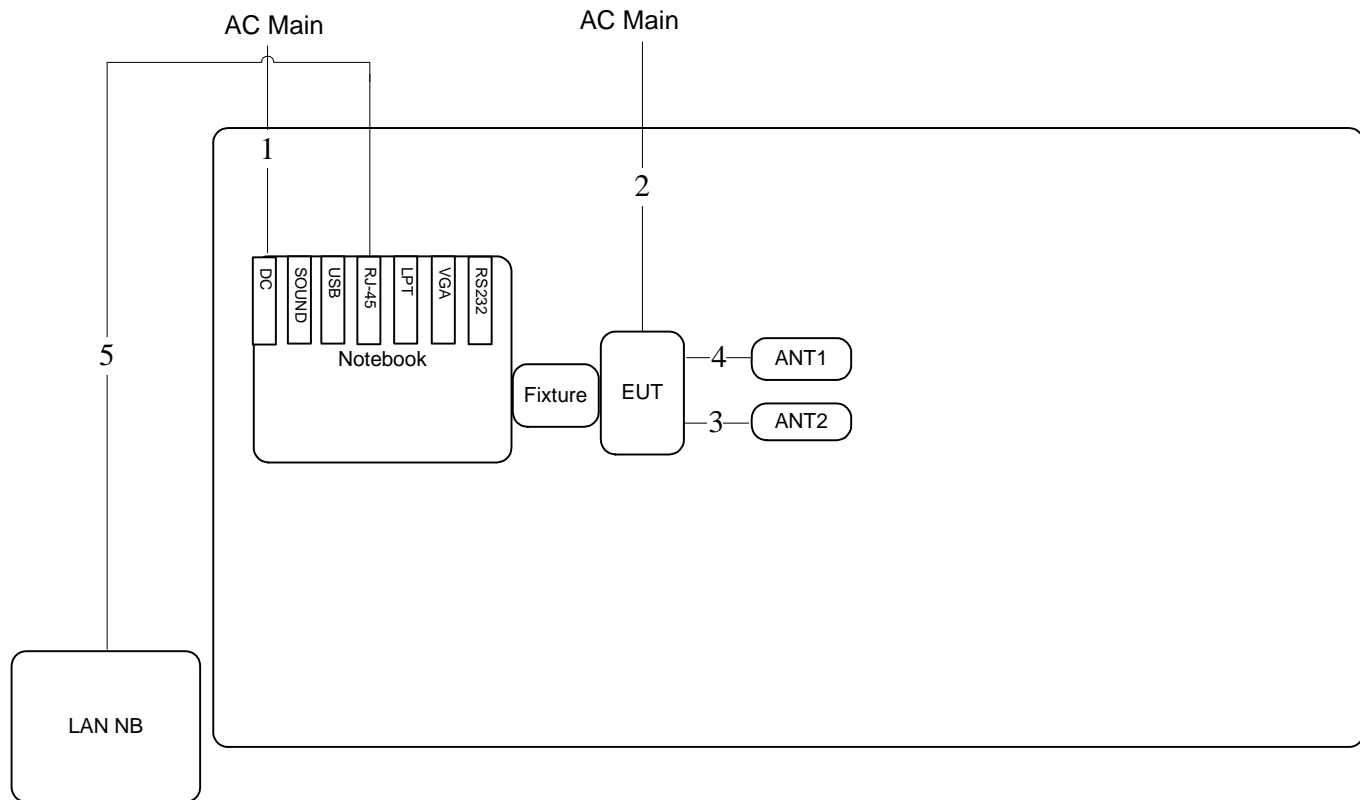

Item	Connection	Shield	Length
1	Power cable	No	1.8m
2	Power cable	No	1.5m
3	Antenna cable	Yes	0.1m
4	Antenna cable	Yes	0.1m
5	RJ-45 cable	No	10m

3.9.2. AC Power Line Conduction Emissions Test Configuration

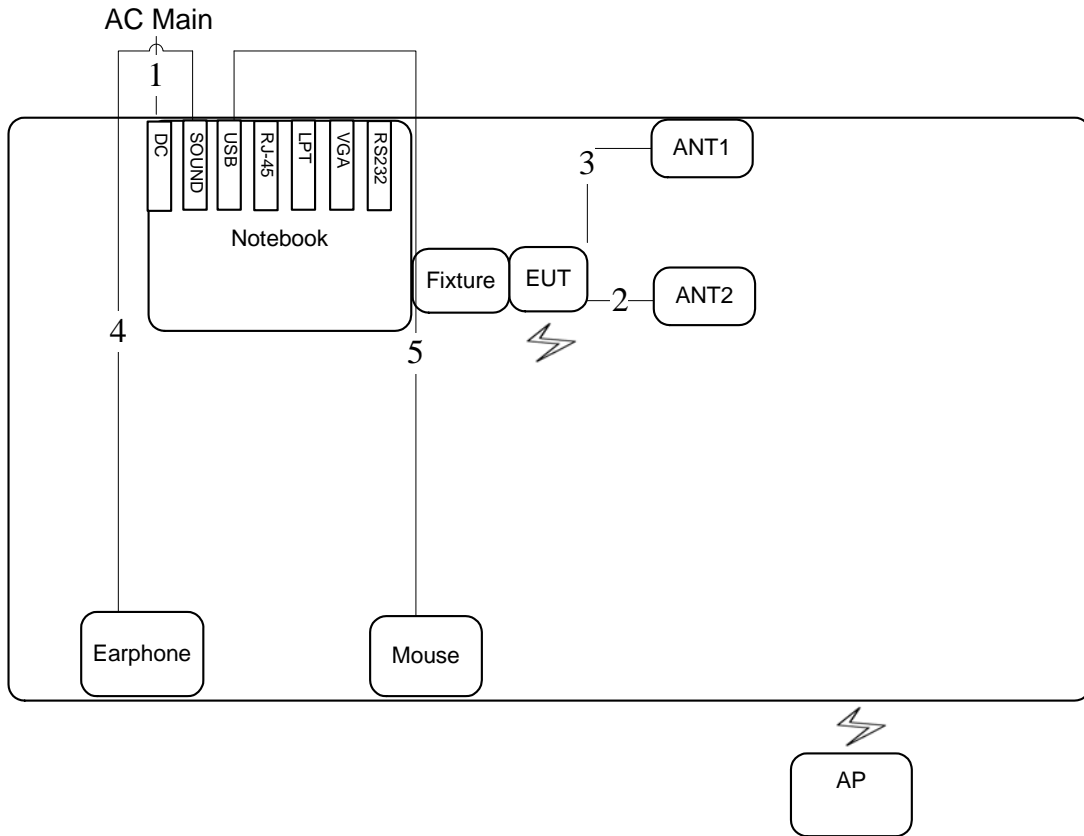

Item	Connection	Shield	Length
1	Power cable	No	1.8m
2	Antenna cable	Yes	0.1m
3	Antenna cable	Yes	0.1m
4	Audio cable	No	1.1m
5	USB cable	No	1.5m

4. TEST RESULT

4.1. AC Power Line Conducted Emissions Measurement

4.1.1. Limit

For this product which is designed to be connected to the AC power line, the radio frequency voltage that is conducted back onto the AC power line on any frequency or frequencies within the band 150 kHz to 30 MHz shall not exceed below limits table.

Frequency (MHz)	QP Limit (dBuV)	AV Limit (dBuV)
0.15~0.5	66~56	56~46
0.5~5	56	46
5~30	60	50

4.1.2. Measuring Instruments and Setting

Please refer to section 5 of equipments list in this report. The following table is the setting of the receiver.

Receiver Parameters	Setting
Attenuation	10 dB
Start Frequency	0.15 MHz
Stop Frequency	30 MHz
IF Bandwidth	9 KHz

4.1.3. Test Procedures

1. Configure the EUT according to ANSI C63.10. The EUT or host of EUT has to be placed 0.4 meter far from the conducting wall of the shielding room and at least 80 centimeters from any other grounded conducting surface.
2. Connect EUT or host of EUT to the power mains through a line impedance stabilization network (LISN).
3. All the support units are connected to the other LISNs. The LISN should provide 50uH/50ohms coupling impedance.
4. The frequency range from 150 KHz to 30 MHz was searched.
5. Set the test-receiver system to Peak Detect Function and Specified Bandwidth with Maximum Hold Mode.
6. The measurement has to be done between each power line and ground at the power terminal.

4.1.4. Test Setup Layout

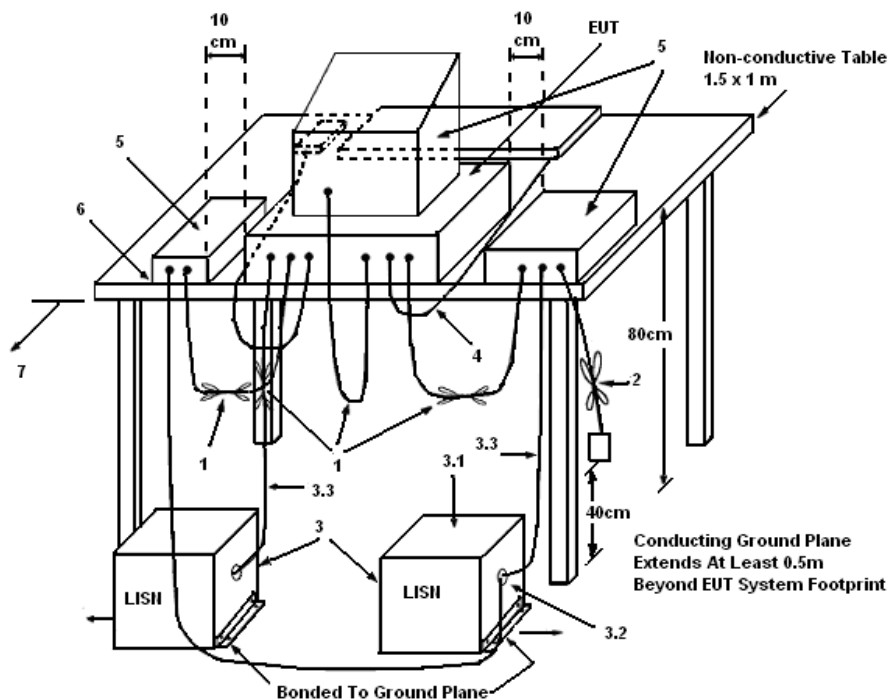

LEGEND:

- (1) Interconnecting cables that hang closer than 40 cm to the ground plane shall be folded back and forth in the center forming a bundle 30 to 40 cm long.
- (2) I/O cables that are not connected to a peripheral shall be bundled in the center. The end of the cable may be terminated, if required, using the correct terminating impedance. The overall length shall not exceed 1 m.
- (3) EUT connected to one LISN. Unused LISN measuring port connectors shall be terminated in 50 Ω . LISN can be placed on top of, or immediately beneath, reference ground plane.
 - (3.1) All other equipment powered from additional LISN(s).
 - (3.2) Multiple outlet strip can be used for multiple power cords of non-EUT equipment.
 - (3.3) LISN at least 80 cm from nearest part of EUT chassis.
- (4) Cables of hand-operated devices, such as keyboards, mice, etc., shall be placed as for normal use.
- (5) Non-EUT components of EUT system being tested.
- (6) Rear of EUT, including peripherals, shall all be aligned and flush with rear of tabletop.
- (7) Rear of tabletop shall be 40 cm removed from a vertical conducting plane that is bonded to the ground plane.

4.1.5. Test Deviation

There is no deviation with the original standard.

4.1.6. EUT Operation during Test

The EUT was placed on the test table and programmed in normal function.

4.1.7. Results of AC Power Line Conducted Emissions Measurement

Temperature	24°C	Humidity	60%
Test Engineer	Hank Yang	Phase	Line
Configuration	Normal Link		

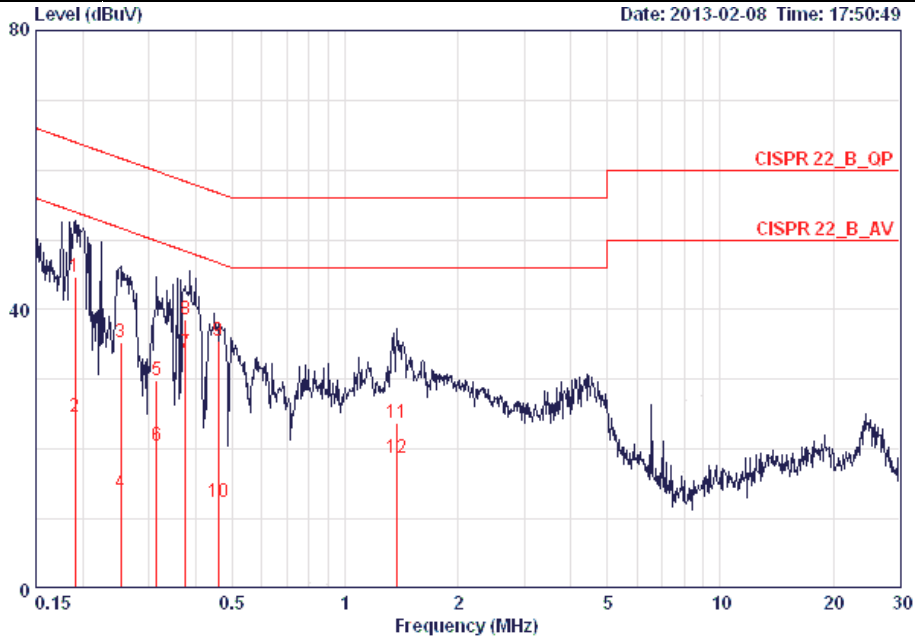

	Freq	Level	Over Limit	Limit Line	Read Level	LISN Factor	Cable Loss	Remark
	MHz	dBuV	dB	dBuV	dBuV	dB	dB	
1	0.19039	44.70	-19.32	64.02	44.35	0.15	0.20	QP
2	0.19039	24.69	-29.33	54.02	24.34	0.15	0.20	AVERAGE
3	0.25211	35.30	-26.39	61.69	34.95	0.15	0.20	QP
4	0.25211	13.68	-38.01	51.69	13.33	0.15	0.20	AVERAGE
5	0.31495	29.87	-29.97	59.84	29.52	0.15	0.20	QP
6	0.31495	20.42	-29.42	49.84	20.07	0.15	0.20	AVERAGE
7 @	0.37578	33.83	-14.54	48.37	33.48	0.15	0.20	AVERAGE
8	0.37578	38.48	-19.89	58.37	38.13	0.15	0.20	QP
9	0.45878	35.53	-21.18	56.71	35.18	0.15	0.20	QP
10	0.45878	12.48	-34.23	46.71	12.13	0.15	0.20	AVERAGE
11	1.374	23.74	-32.26	56.00	23.35	0.18	0.21	QP
12	1.374	18.65	-27.35	46.00	18.26	0.18	0.21	AVERAGE

Temperature	24°C	Humidity	60%
Test Engineer	Hank Yang	Phase	Neutral
Configuration	Normal Link		

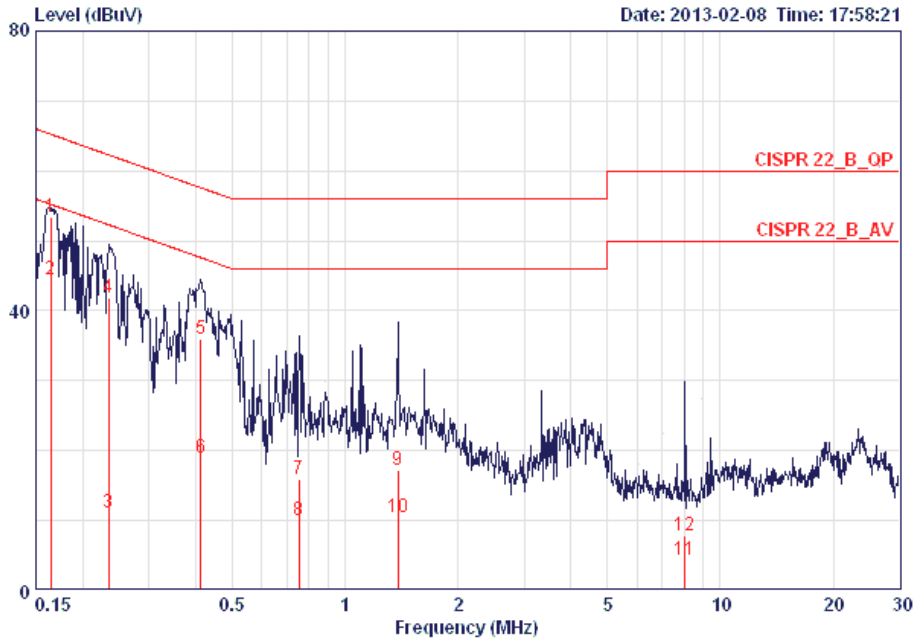

	Freq	Level	Over Limit	Limit Line	Read Level	LISN Factor	Cable Loss	Remark
	MHz	dBuV	dB	dBuV	dBuV	dB	dB	
1	0.16414	53.45	-11.81	65.25	53.18	0.08	0.19	QP
2	0.16414	44.52	-10.74	55.25	44.25	0.08	0.19	AVERAGE
3	0.23409	11.16	-41.14	52.30	10.88	0.08	0.20	AVERAGE
4	0.23409	41.96	-20.34	62.30	41.68	0.08	0.20	QP
5	0.41266	36.06	-21.53	57.59	35.78	0.08	0.20	QP
6	0.41266	18.86	-28.73	47.59	18.58	0.08	0.20	AVERAGE
7	0.75493	15.93	-40.07	56.00	15.64	0.09	0.20	QP
8	0.75493	10.13	-35.87	46.00	9.84	0.09	0.20	AVERAGE
9	1.381	17.22	-38.78	56.00	16.91	0.10	0.21	QP
10	1.381	10.52	-35.48	46.00	10.21	0.10	0.21	AVERAGE
11	8.062	4.28	-45.72	50.00	3.78	0.20	0.30	AVERAGE
12	8.062	7.76	-52.24	60.00	7.26	0.20	0.30	QP

Note:

Level = Read Level + LISN Factor + Cable Loss

4.2. Maximum Conducted Output Power Measurement

4.2.1. Limit

For systems using digital modulation in the 2400-2483.5MHz, the limit for output power is 30dBm. The limited has to be reduced by the amount in dB that the gain of the antenna exceed 6dBi. In case of point-to-point operation, the limit has to be reduced by 1dB for every 3dB that the directional gain of the antenna exceeds 6dBi. Systems operating in the 5725-5850 MHz band that are used exclusively for fixed, point-to-point operations may employ transmitting antennas with directional gain greater than 6 dBi without any corresponding reduction in transmitter output power.

4.2.2. Measuring Instruments and Setting

Please refer to section 5 of equipments list in this report. The following table is the setting of the power meter.

Power Meter Parameter	Setting
Bandwidth	50MHz bandwidth is greater than the EUT emission bandwidth
Detector	Average

4.2.3. Test Procedures

1. Test procedures refer KDB558074 v01 r02 section 8.2.3 option 3.
2. This procedure provides an alternative for determining the RMS output power using a broadband RF average power meter with a thermocouple detector.

4.2.4. Test Setup Layout

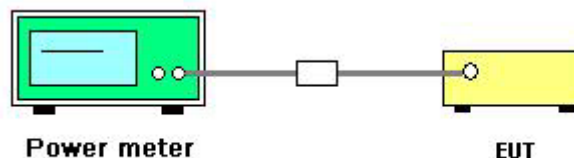

4.2.5. Test Deviation

There is no deviation with the original standard.

4.2.6. EUT Operation during Test

The EUT was programmed to be in continuously transmitting mode.

4.2.7. Test Result of Maximum Conducted Output Power

Temperature	25°C	Humidity	56%
Test Engineer	Robert Chang	Configurations	IEEE 802.11n
Test Date	Feb. 04, 2013		

For 2.4GHz Band

Configuration IEEE 802.11n MCS0 20MHz / Chain 1+ Chain 2 (2TX)

Channel	Frequency	Conducted Power (dBm)		Total Conducted Power (dBm)	Max. Limit (dBm)	Result
		Chain 1	Chain 2			
1	2412 MHz	14.80	15.95	18.42	30.00	Complies
6	2437 MHz	14.61	14.95	17.79	30.00	Complies
11	2462 MHz	15.50	15.92	18.73	30.00	Complies

Configuration IEEE 802.11n MCS0 40MHz / Chain 1 + Chain 2 (2TX)

Channel	Frequency	Conducted Power (dBm)		Total Conducted Power (dBm)	Max. Limit (dBm)	Result
		Chain 1	Chain 2			
3	2422 MHz	14.36	16.30	18.45	30.00	Complies
6	2437 MHz	14.50	16.60	18.69	30.00	Complies
9	2452 MHz	15.50	15.92	18.73	30.00	Complies

For 5GHz Band

Configuration IEEE 802.11n MCS0 20MHz / Chain 1 + Chain 2 (2TX)

Channel	Frequency	Conducted Power (dBm)		Total Conducted Power (dBm)	Max. Limit (dBm)	Result
		Chain 1	Chain 2			
149	5745 MHz	21.34	20.57	23.98	30.00	Complies
157	5785 MHz	21.06	19.71	23.45	30.00	Complies
165	5825 MHz	20.54	18.88	22.80	30.00	Complies

Configuration IEEE 802.11n MCS0 40MHz / Chain 1 + Chain 2 (2TX)

Channel	Frequency	Conducted Power (dBm)		Total Conducted Power (dBm)	Max. Limit (dBm)	Result
		Chain 1	Chain 2			
151	5755 MHz	21.62	20.43	24.08	30.00	Complies
159	5795 MHz	20.92	19.68	23.35	30.00	Complies

Temperature	25°C	Humidity	56%
Test Engineer	Robert Chang	Configurations	IEEE 802.11a/b/g
Test Date	Feb. 04, 2013		

Configuration IEEE 802.11b / Chain 1 (1TX)

Channel	Frequency	Conducted Power (dBm)	Max. Limit (dBm)	Result
1	2412 MHz	20.28	30.00	Complies
6	2437 MHz	20.14	30.00	Complies
11	2462 MHz	20.50	30.00	Complies

Configuration IEEE 802.11g / Chain 1+ Chain 2 (2TX)

Channel	Frequency	Conducted Power (dBm)		Total Conducted Power (dBm)	Max. Limit (dBm)	Result
		Chain 1	Chain 2			
1	2412 MHz	16.30	16.50	19.41	30.00	Complies
6	2437 MHz	15.16	16.16	18.70	30.00	Complies
11	2462 MHz	16.30	16.62	19.47	30.00	Complies

Configuration IEEE 802.11a / Chain 1 + Chain 2 (2TX)

Channel	Frequency	Conducted Power (dBm)		Total Conducted Power (dBm)	Max. Limit (dBm)	Result
		Chain 1	Chain 2			
149	5745 MHz	21.66	20.74	24.23	30.00	Complies
157	5785 MHz	21.12	20.22	23.70	30.00	Complies
165	5825 MHz	20.83	19.20	23.10	30.00	Complies

4.3. Power Spectral Density Measurement

4.3.1. Limit

For digitally modulated systems, the power spectral density conducted from the intentional radiator to the antenna shall not be greater than 8dBm in any 3 kHz band during any time interval of continuous transmission.

4.3.2. Measuring Instruments and Setting

Please refer to section 5 of equipments list in this report. The following table is the setting of the spectrum analyzer.

Spectrum Parameter	Setting
Attenuation	Auto
Span Frequency	Set the span to 1.5 times the DTS channel bandwidth.
RB	100 kHz
VB	300 kHz
Detector	Peak
Trace	Max Hold
Sweep Time	Auto couple

4.3.3. Test Procedures

1. Test procedures refer KDB558074 v01 r02 section 9.1 option 1
2. Spectrum analyzer must be capable of utilizing a number of measurement points in each sweep that is greater than or equal to twice the span/RBW in order to ensure bin-to-bin spacing of $\leq RBW/2$ so that narrowband signals are not lost between frequency bins.
3. Use this procedure when the maximum conducted output power in the fundamental emission is used to demonstrate compliance. The EUT must be configured to transmit continuously at full power over the measurement duration.
4. Ensure that the number of measurement points in the sweep $\geq 2 \times \text{span}/\text{RBW}$ (use of a greater number of measurement points than this minimum requirement is recommended).
5. Use the peak marker function to determine the maximum level in any 100 kHz band segment within the fundamental EBW.
6. Scale the observed power level to an equivalent level in 3 kHz by adjusting (reducing) the measured power by a bandwidth correction factor (BWCF) where: $BWCF = 10\log(3 \text{ kHz}/100 \text{ kHz} = -15.2 \text{ dB})$.
7. The resulting PSD level must be $\leq 8 \text{ dBm}$.
8. When measuring power spectral density with multiple antenna systems, add every result of the values by mathematic formula.

4.3.4. Test Setup Layout

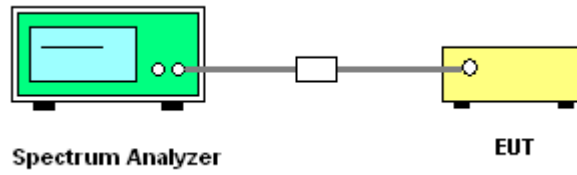

4.3.5. Test Deviation

There is no deviation with the original standard.

4.3.6. EUT Operation during Test

The EUT was programmed to be in continuously transmitting mode.

4.3.7. Test Result of Power Spectral Density

Temperature	25°C	Humidity	56%
Test Engineer	Robert Chang	Configurations	IEEE 802.11n

For 2.4GHz Band

Configuration IEEE 802.11n MCS0 20MHz / Chain 1 + Chain 2 (2TX)

Channel	Frequency	Power Density (dBm/100kHz)		BWCF factor (100kHz to 3kHz)	Power Density (dBm/3kHz)		Single Port Limit (dBm/3kHz)	Result
		Chain 1	Chain 2		Chain 1	Chain 2		
1	2412 MHz	0.07	1.63	-15.23	-15.16	-13.60	4.99	Complies
6	2437 MHz	-0.24	0.67	-15.23	-15.47	-14.56	4.99	Complies
11	2462 MHz	1.09	1.26	-15.23	-14.14	-13.97	4.99	Complies

Note: PSD Limit = (8dBm/3kHz - (10log(2)))=4.99dBm/3kHz

Configuration IEEE 802.11n MCS0 40MHz / Chain 1 + Chain 2 (2TX)

Channel	Frequency	Power Density (dBm/100kHz)		BWCF factor (100kHz to 3kHz)	Power Density (dBm/3kHz)		Single Port Limit (dBm/3kHz)	Result
		Chain 1	Chain 2		Chain 1	Chain 2		
3	2422 MHz	-3.37	-0.67	-15.23	-18.60	-15.90	4.99	Complies
6	2437 MHz	-3.00	-1.20	-15.23	-18.23	-16.43	4.99	Complies
9	2452 MHz	-5.17	-3.92	-15.23	-20.40	-19.15	4.99	Complies

Note: PSD Limit = (8dBm/3kHz - (10log(2)))=4.99dBm/3kHz

For 5GHz Band
Configuration IEEE 802.11n MCS0 20MHz / Chain 1 + Chain 2 (2TX)

Channel	Frequency	Power Density (dBm/100kHz)		BWCF factor (100kHz to 3kHz)	Power Density (dBm/3kHz)		Single Port Limit (dBm/3kHz)	Result
		Chain 1	Chain 2		Chain 1	Chain 2		
149	5745 MHz	11.96	10.95	-15.23	-3.27	-4.28	4.99	Complies
157	5785 MHz	12.10	10.81	-15.23	-3.13	-4.42	4.99	Complies
165	5825 MHz	11.31	10.49	-15.23	-3.92	-4.74	4.99	Complies

Note: PSD Limit = (8dBm/3kHz - (10log(2))) = 4.99dBm/3kHz

Configuration IEEE 802.11n MCS0 40MHz / Chain 1 + Chain 2 (2TX)

Channel	Frequency	Power Density (dBm/100kHz)		BWCF factor (100kHz to 3kHz)	Power Density (dBm/3kHz)		Single Port Limit (dBm/3kHz)	Result
		Chain 1	Chain 2		Chain 1	Chain 2		
151	5755 MHz	8.61	7.58	-15.23	-6.62	-7.65	4.99	Complies
159	5795 MHz	7.92	7.08	-15.23	-7.31	-8.15	4.99	Complies

Note: PSD Limit = (8dBm/3kHz - (10log(2))) = 4.99dBm/3kHz

Temperature	25°C	Humidity	56%
Test Engineer	Robert Chang	Configurations	IEEE 802.11a/b/g

Configuration IEEE 802.11b / Chain 1 (1TX)

Channel	Frequency	Power Density (dBm/100kHz)	BWCF factor (100kHz to 3kHz)	Power Density (dBm/3kHz)	Max. Limit (dBm/3kHz)	Result
1	2412 MHz	10.44	-15.23	-4.79	8.00	Complies
6	2437 MHz	10.29	-15.23	-4.94	8.00	Complies
11	2462 MHz	10.64	-15.23	-4.59	8.00	Complies

Configuration IEEE 802.11g / Chain 1+ Chain 2 (2TX)

Channel	Frequency	Power Density (dBm/100kHz)		BWCF factor (100kHz to 3kHz)	Power Density (dBm/3kHz)		Single Port Limit (dBm/3kHz)	Result
		Chain 1	Chain 2		Chain 1	Chain 2		
1	2412 MHz	0.69	2.53	-15.23	-14.54	-12.70	4.99	Complies
6	2437 MHz	0.72	2.00	-15.23	-14.51	-13.23	4.99	Complies
11	2462 MHz	1.81	2.05	-15.23	-13.42	-13.18	4.99	Complies

Note: PSD Limit = (8dBm/3kHz - (10log(2))) = 4.99dBm/3kHz

Configuration IEEE 802.11a / Chain 1+ Chain 2 (2TX)

Channel	Frequency	Power Density (dBm/100kHz)		BWCF factor (100kHz to 3kHz)	Power Density (dBm/3kHz)		Single Port Limit (dBm/3kHz)	Result
		Chain 1	Chain 2		Chain 1	Chain 2		
149	5745 MHz	12.07	11.38	-15.23	-3.16	-3.85	4.99	Complies
157	5785 MHz	11.26	10.62	-15.23	-3.97	-4.61	4.99	Complies
165	5825 MHz	11.55	10.44	-15.23	-3.68	-4.79	4.99	Complies

Note: PSD Limit = (8dBm/3kHz - (10log(2))) = 4.99dBm/3kHz

Note: All the test values were listed in the report.

For plots, only the channel with maximum results was shown.

Power Density Plot on Configuration IEEE 802.11n MCS0 20MHz / Chain 2 / 2412 MHz

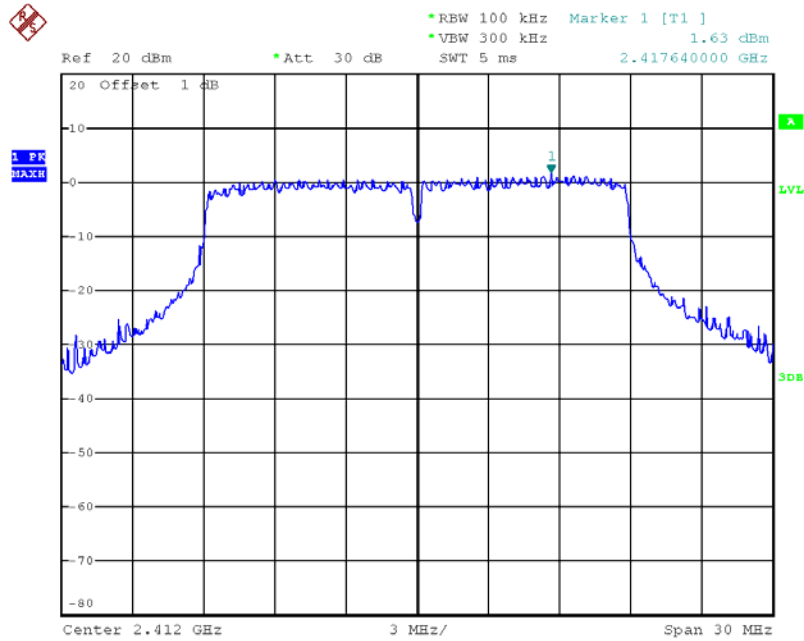

Date: 4.FEB.2013 18:01:35

Power Density Plot on Configuration IEEE 802.11n MCS0 40MHz / Chain 2 / 2422 MHz

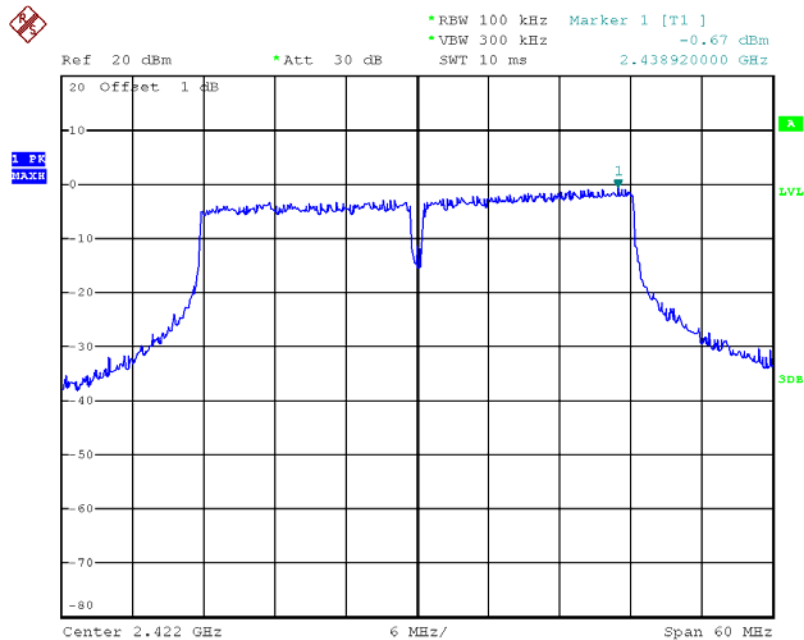

Date: 4.FEB.2013 18:09:19

Power Density Plot on Configuration IEEE 802.11n MCS0 20MHz / Chain 1 / 5785 MHz

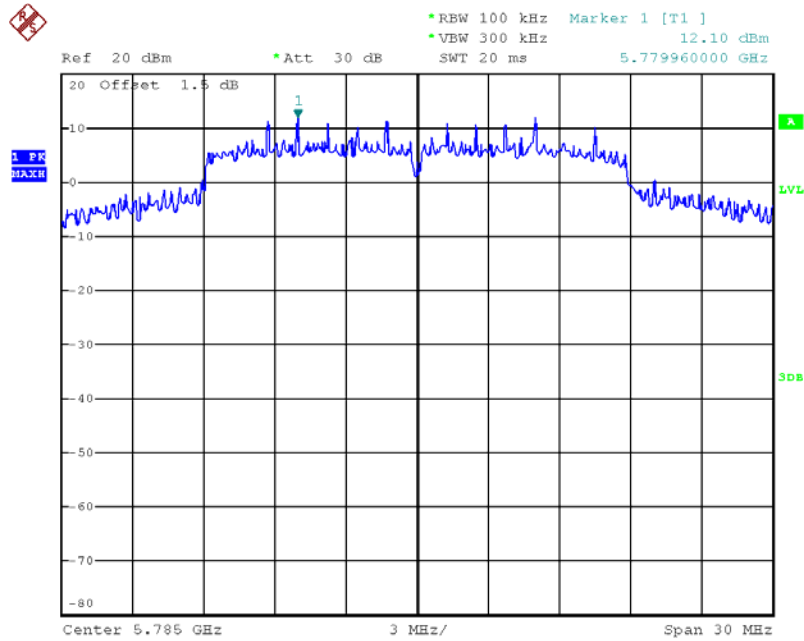

Date: 7.FEB.2013 10:40:15

Power Density Plot on Configuration IEEE 802.11n MCS0 40MHz / Chain 1 / 5755 MHz

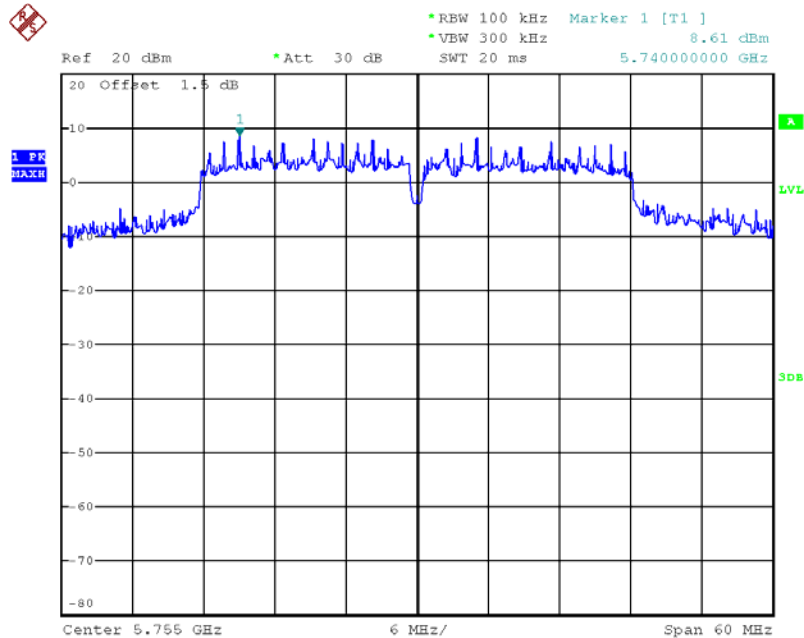

Date: 7.FEB.2013 10:42:38

Power Density Plot on Configuration IEEE 802.11b / Chain 1 / 2462 MHz

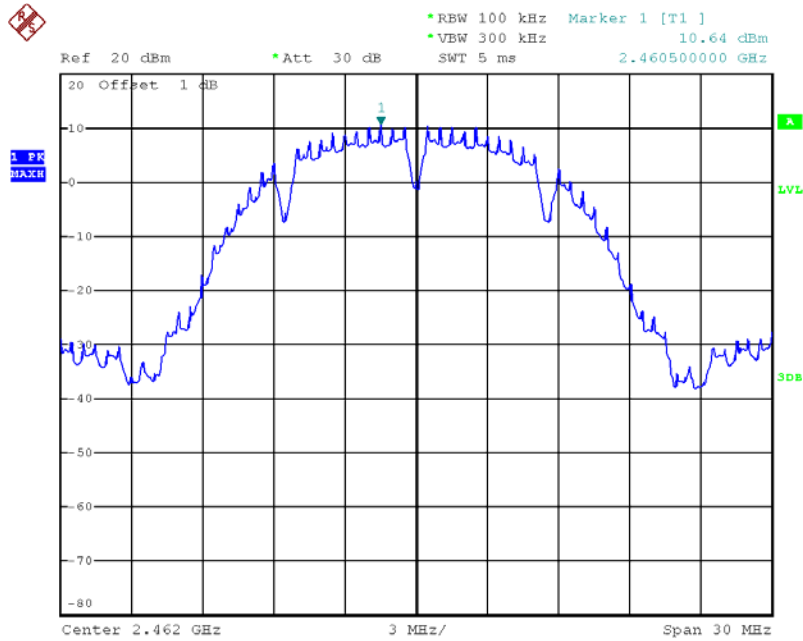

Date: 4.FEB.2013 17:51:43

Power Density Plot on Configuration IEEE 802.11g / Chain 2 / 2412 MHz

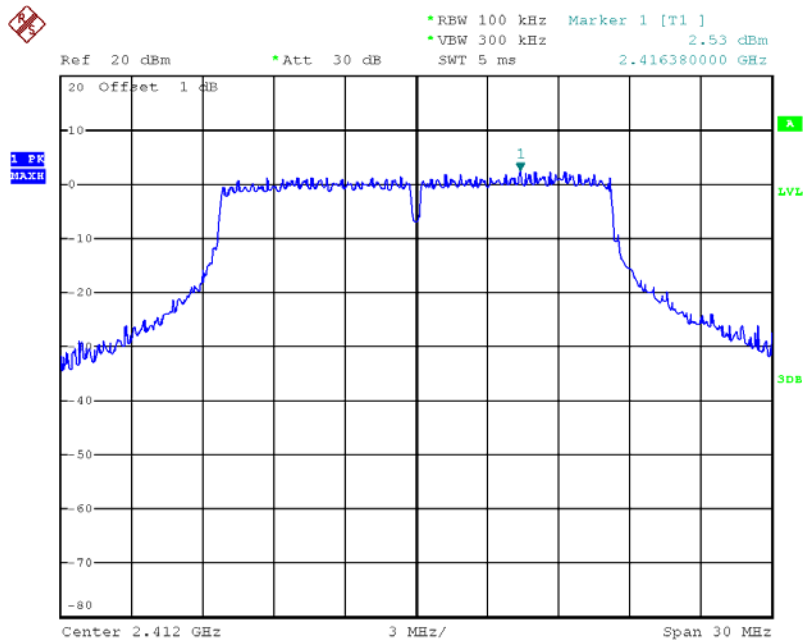

Date: 4.FEB.2013 17:56:44

Power Density Plot on Configuration IEEE 802.11a / Chain 1 / 5745 MHz

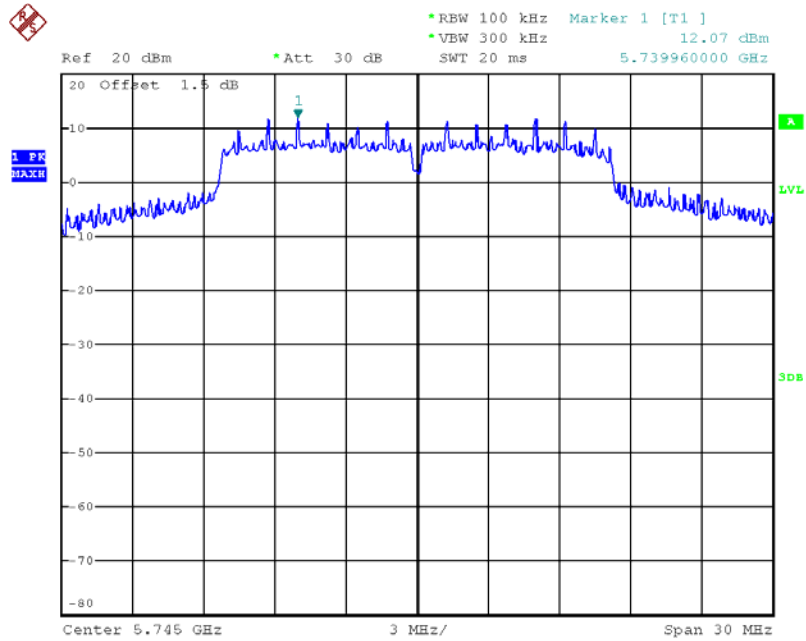

Date: 7.FEB.2013 10:35:13

4.4. 6dB Spectrum Bandwidth Measurement

4.4.1. Limit

For digital modulation systems, the minimum 6dB bandwidth shall be at least 500 kHz.

4.4.2. Measuring Instruments and Setting

Please refer to section 5 of equipments list in this report. The following table is the setting of the spectrum analyzer.

Spectrum Parameters	Setting
Attenuation	Auto
Span Frequency	> 6dB Bandwidth
RB	1-5 % or DTS BW, not exceed 100KHz
VB	$\geq 3 \times \text{RBW}$
Detector	Peak
Trace	Max Hold
Sweep Time	Auto

4.4.3. Test Procedures

1. The transmitter output (antenna port) was connected to the spectrum analyzer in peak hold mode.
2. Test was performed in accordance with KDB 558074 Guidance for Performing Compliance Measurements on Digital Transmission Systems (DTS) Operating Under §15.247 section 5.1.1 EBW Measurement Procedure
3. Multiple antenna system was performed in accordance with KDB 662911 Emissions Testing of Transmitters with Multiple Outputs in the Same Band.
4. Measured the spectrum width with power higher than 6dB below carrier.

4.4.4. Test Setup Layout

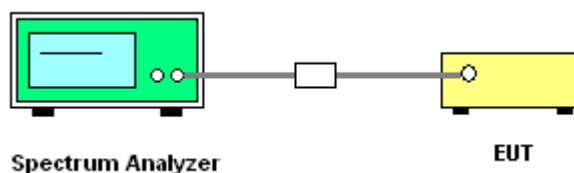

4.4.5. Test Deviation

There is no deviation with the original standard.

4.4.6. EUT Operation during Test

The EUT was programmed to be in continuously transmitting mode.

4.4.7. Test Result of 6dB Spectrum Bandwidth

Temperature	25°C	Humidity	56%
Test Engineer	Robert Chang	Configurations	IEEE 802.11n

For 2.4GHz Band

Configuration IEEE 802.11n MCS0 20MHz / Chain 1 + Chain 2 (2TX)

Channel	Frequency	6dB Bandwidth (MHz)	99% Occupied Bandwidth (MHz)	Min. Limit (kHz)	Test Result
1	2412 MHz	17.84	17.92	500	Complies
6	2437 MHz	17.68	18.00	500	Complies
11	2462 MHz	17.68	17.92	500	Complies

Configuration IEEE 802.11n MCS0 40MH / Chain 1 + Chain 2 (2TX)

Channel	Frequency	6dB Bandwidth (MHz)	99% Occupied Bandwidth (MHz)	Min. Limit (kHz)	Test Result
3	2422 MHz	36.64	36.80	500	Complies
6	2437 MHz	36.48	36.48	500	Complies
9	2452 MHz	36.48	36.64	500	Complies

For 5GHz Band

Configuration IEEE 802.11n MCS0 20MHz / Chain 1 + Chain 2 (2TX)

Channel	Frequency	6dB Bandwidth (MHz)	99% Occupied Bandwidth (MHz)	Min. Limit (kHz)	Test Result
149	5745 MHz	15.36	28.72	500	Complies
157	5785 MHz	16.00	28.32	500	Complies
165	5825 MHz	15.36	27.52	500	Complies

Configuration IEEE 802.11n MCS0 40MHz / Chain 1 + Chain 2 (2TX)

Channel	Frequency	6dB Bandwidth (MHz)	99% Occupied Bandwidth (MHz)	Min. Limit (kHz)	Test Result
151	5755 MHz	35.04	63.84	500	Complies
159	5795 MHz	34.56	62.56	500	Complies

Temperature	25°C	Humidity	56%
Test Engineer	Robert Chang	Configurations	IEEE 802.11a/b/g

Configuration IEEE 802.11b / Chain 1 (1TX)

Channel	Frequency	6dB Bandwidth (MHz)	99% Occupied Bandwidth (MHz)	Min. Limit (kHz)	Test Result
1	2412 MHz	10.00	14.24	500	Complies
6	2437 MHz	10.08	14.08	500	Complies
11	2462 MHz	10.08	14.16	500	Complies

Configuration IEEE 802.11g / Chain 1 + Chain 2 (2TX)

Channel	Frequency	6dB Bandwidth (MHz)	99% Occupied Bandwidth (MHz)	Min. Limit (kHz)	Test Result
1	2412 MHz	16.48	16.72	500	Complies
6	2437 MHz	16.48	16.64	500	Complies
11	2462 MHz	16.40	16.64	500	Complies

Configuration IEEE 802.11a / Chain 1 + Chain 2 (2TX)

Channel	Frequency	6dB Bandwidth (MHz)	99% Occupied Bandwidth (MHz)	Min. Limit (kHz)	Test Result
149	5745 MHz	15.60	29.92	500	Complies
157	5785 MHz	15.68	29.76	500	Complies
165	5825 MHz	15.68	27.92	500	Complies

Note: All the test values were listed in the report.

For plots, only the channel with maximum results was shown.

6 dB Bandwidth Plot on Configuration IEEE 802.11n MCS0 20MHz / Chain 1 + Chain 2 / 2462 MHz

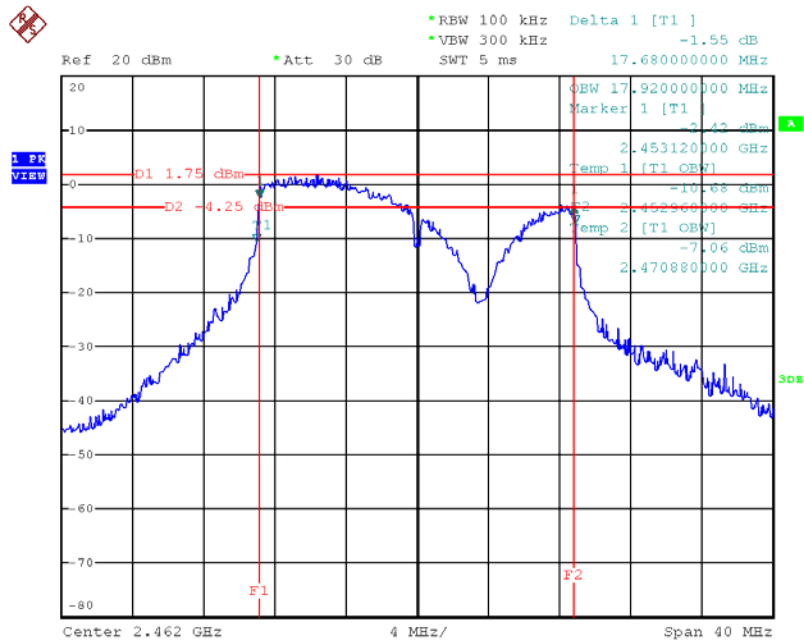

Date: 4.FEB.2013 18:43:31

6 dB Bandwidth Plot on Configuration IEEE 802.11n MCS0 40MHz / Chain 1 + Chain 2 / 2437 MHz

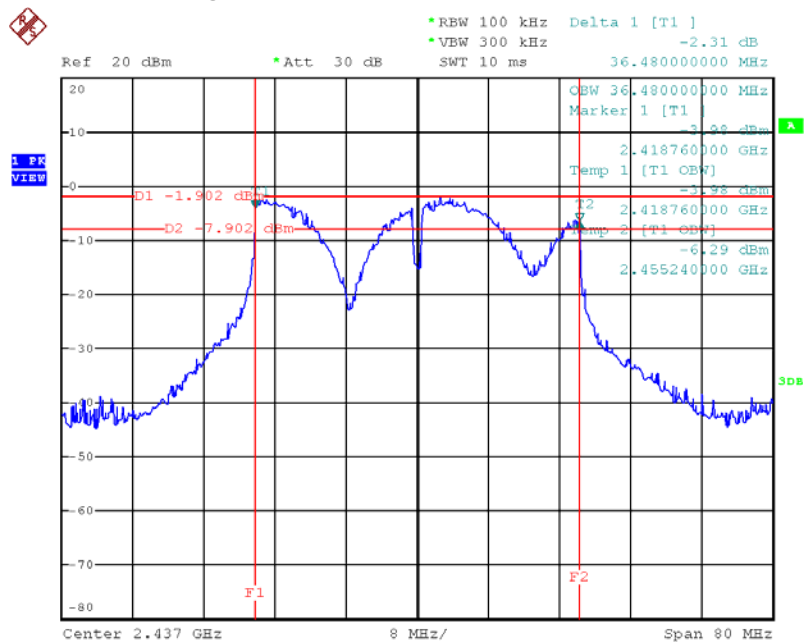

Date: 4.FEB.2013 18:48:03

6 dB Bandwidth Plot on Configuration IEEE 802.11n MCS0 20MHz / Chain 1 + Chain 2 / 5745MHz

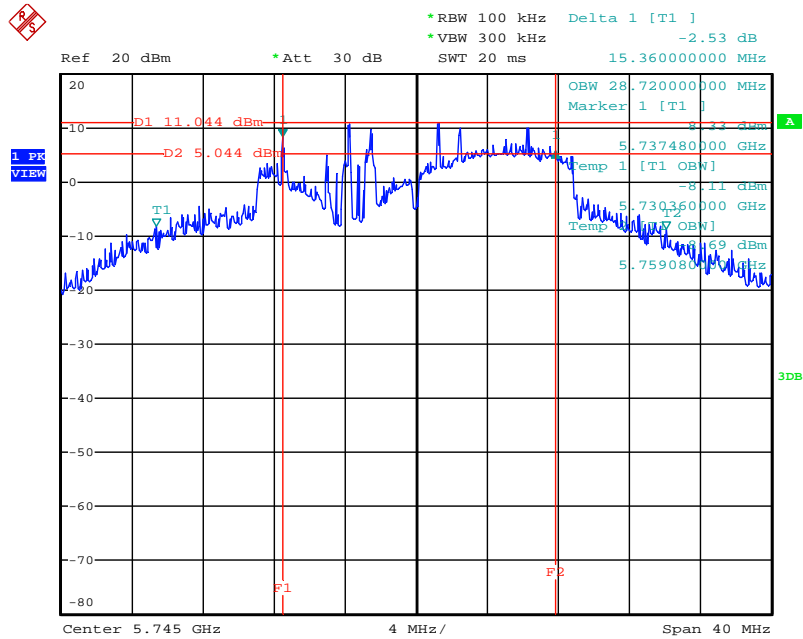

Date: 7.FEB.2013 10:22:24

6 dB Bandwidth Plot on Configuration IEEE 802.11n MCS0 40MHz / Chain 1 + Chain 2 / 5795MHz

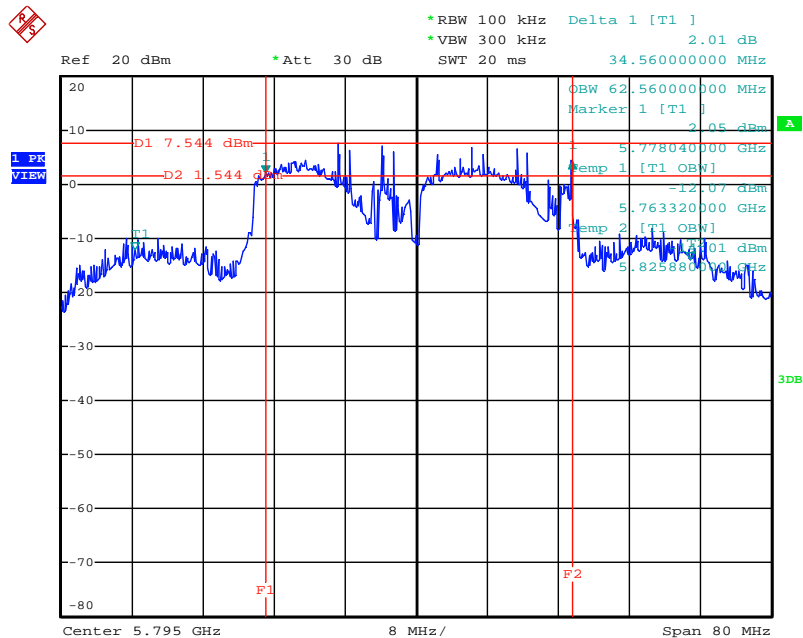

Date: 7.FEB.2013 10:23:51

6 dB Bandwidth Plot on Configuration IEEE 802.11b / Chain 1 / 2412 MHz

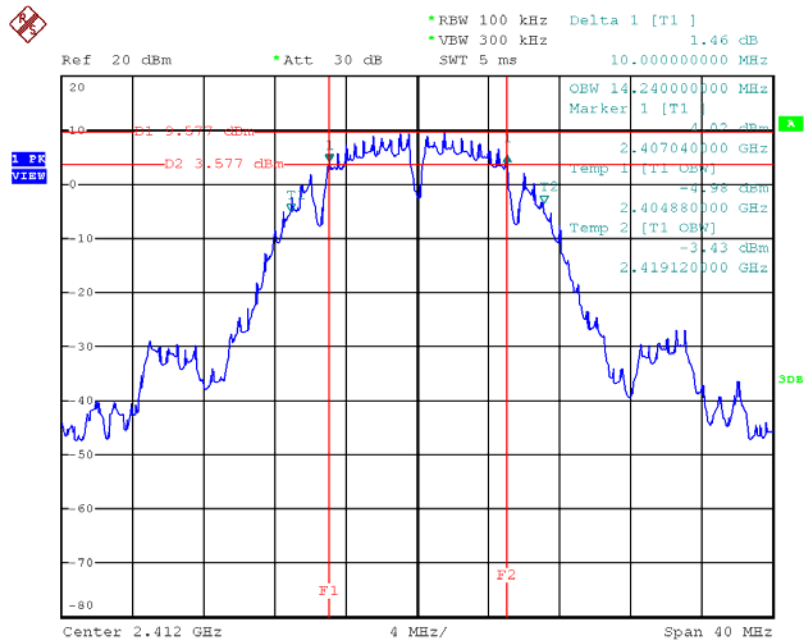

Date: 4.FEB.2013 18:32:00

6 dB Bandwidth Plot on Configuration IEEE 802.11g / Chain 1 + Chain 2 / 2462MHz

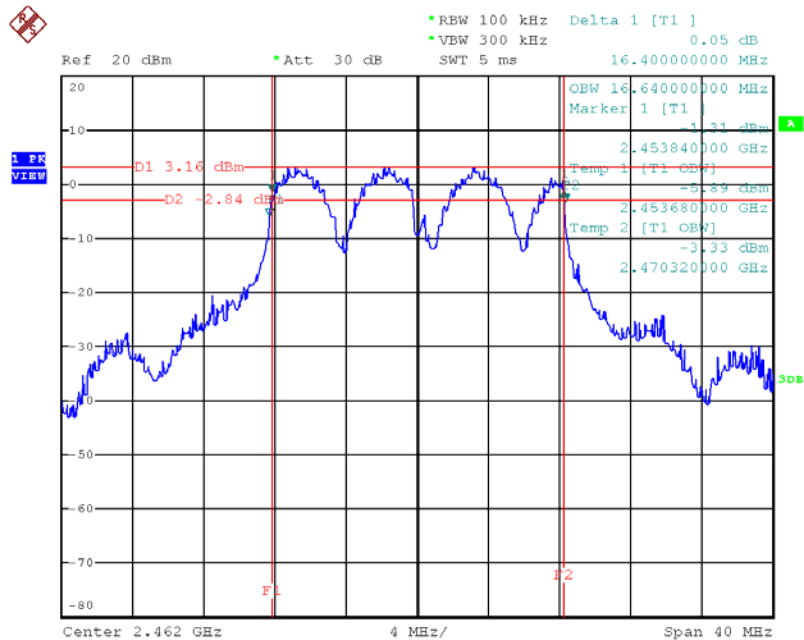

Date: 4.FEB.2013 18:38:36

6 dB Bandwidth Plot on Configuration IEEE 802.11a / Chain 1 + Chain 2 / 5745 MHz

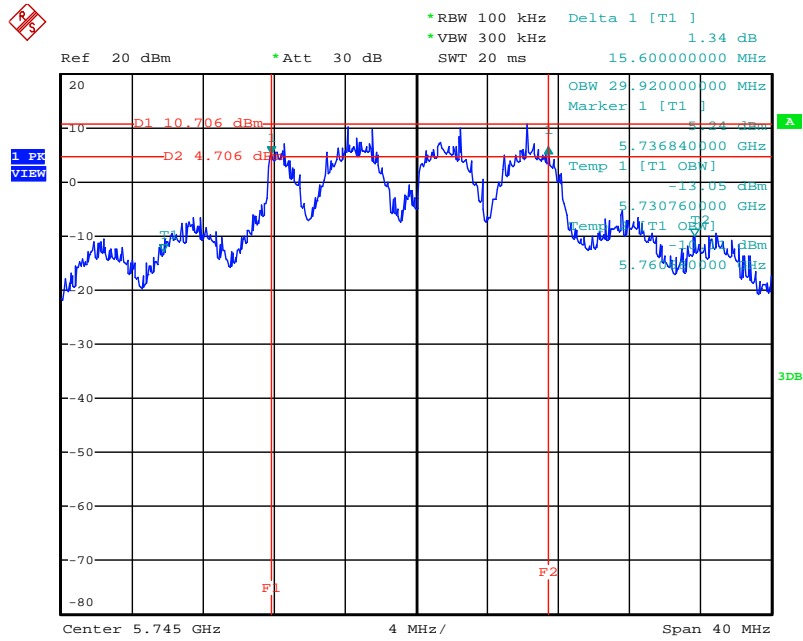

Date: 7.FEB.2013 10:20:22

4.5. Radiated Emissions Measurement

4.5.1. Limit

30dBc in any 100 kHz bandwidth outside the operating frequency band. In case the emission fall within the restricted band specified on 15.205(a), then the 15.209(a) limit in the table below has to be followed.

Frequencies (MHz)	Field Strength (micorvolts/meter)	Measurement Distance (meters)
0.009~0.490	2400/F(KHz)	300
0.490~1.705	24000/F(KHz)	30
1.705~30.0	30	30
30~88	100	3
88~216	150	3
216~960	200	3
Above 960	500	3

4.5.2. Measuring Instruments and Setting

Please refer to section 5 of equipments list in this report. The following table is the setting of spectrum analyzer and receiver.

Spectrum Parameter	Setting
Attenuation	Auto
Start Frequency	1000 MHz
Stop Frequency	10th carrier harmonic
RB / VB (Emission in restricted band)	1MHz / 3MHz for Peak, 1 MHz / 10Hz for Average
RB / VB (Emission in non-restricted band)	100kHz / 300kHz for peak

Receiver Parameter	Setting
Attenuation	Auto
Start ~ Stop Frequency	9kHz~150kHz / RB 200Hz for QP
Start ~ Stop Frequency	150kHz~30MHz / RB 9kHz for QP
Start ~ Stop Frequency	30MHz~1000MHz / RB 120kHz for QP

4.5.3. Test Procedures

1. Configure the EUT according to ANSI C63.10. The EUT was placed on the top of the turntable 0.8 meter above ground. The phase center of the receiving antenna mounted on the top of a height-variable antenna tower was placed 3 meters far away from the turntable.
2. Power on the EUT and all the supporting units. The turntable was rotated by 360 degrees to determine the position of the highest radiation.
3. The height of the broadband receiving antenna was varied between one meter and four meters above ground to find the maximum emissions field strength of both horizontal and vertical polarization.
4. For each suspected emissions, the antenna tower was scan (from 1 M to 4 M) and then the turntable was rotated (from 0 degree to 360 degrees) to find the maximum reading.
5. Set the test-receiver system to Peak or CISPR quasi-peak Detect Function with specified bandwidth under Maximum Hold Mode.
6. For emissions above 1GHz, use 1MHz VBW and 3MHz RBW for peak reading. Then 1MHz RBW and 10Hz VBW for average reading in spectrum analyzer.
7. When the radiated emissions limits are expressed in terms of the average value of the emissions, and pulsed operation is employed, the measurement field strength shall be determined by averaging over one complete pulse train, including blanking intervals, as long as the pulse train does not exceed 0.1 seconds. As an alternative (provided the transmitter operates for longer than 0.1 seconds) or in cases where the pulse train exceeds 0.1 seconds, the measured field strength shall be determined from the average absolute voltage during a 0.1 second interval during which the field strength is at its maximum value.
8. If the emissions level of the EUT in peak mode was 3 dB lower than the average limit specified, then testing will be stopped and peak values of EUT will be reported, otherwise, the emissions which do not have 3 dB margin will be repeated one by one using the quasi-peak method for below 1GHz.
9. For testing above 1GHz, the emissions level of the EUT in peak mode was lower than average limit (that means the emissions level in peak mode also complies with the limit in average mode), then testing will be stopped and peak values of EUT will be reported, otherwise, the emissions will be measured in average mode again and reported.
10. In case the emission is lower than 30MHz, loop antenna has to be used for measurement and the recorded data should be QP measured by receiver. High – Low scan is not required in this case.

4.5.4. Test Setup Layout

For radiated emissions below 1GHz

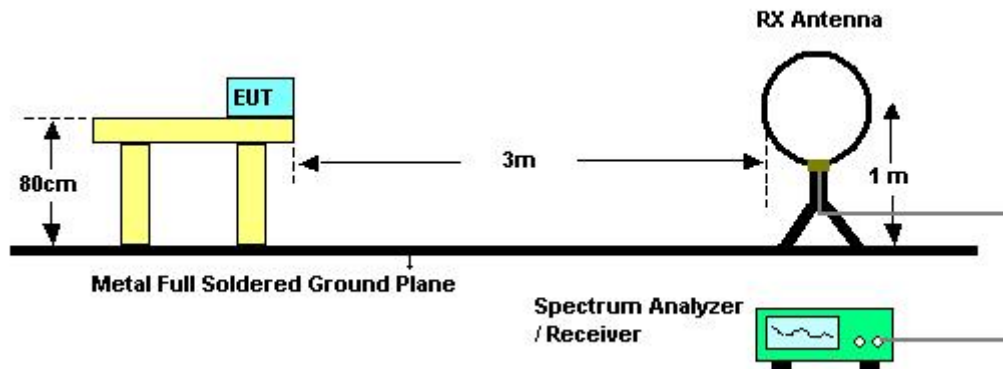

For radiated emissions above 1GHz

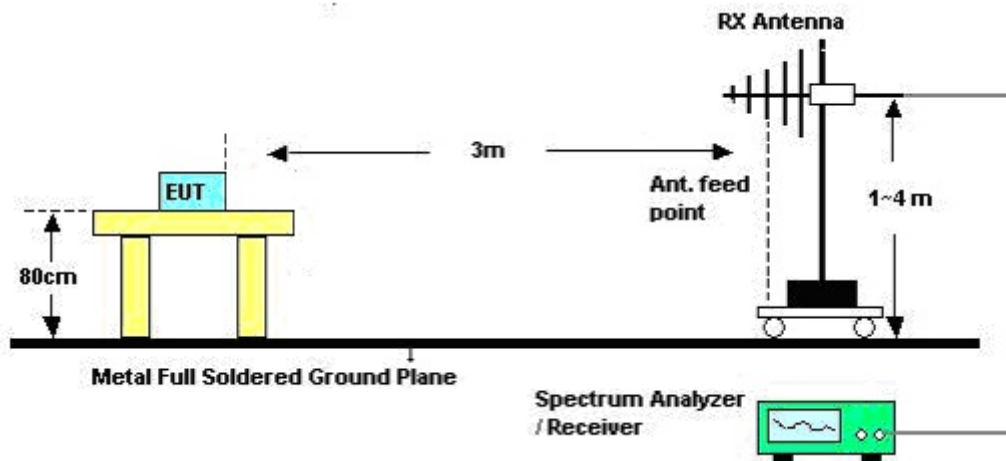

4.5.5. Test Deviation

There is no deviation with the original standard.

4.5.6. EUT Operation during Test

The EUT was programmed to be in continuously transmitting mode.

4.5.7. Results of Radiated Emissions (9kHz~30MHz)

Temperature	26°C	Humidity	60%
Test Engineer	Jim Huang	Configurations	Normal Link
Test Date	Feb. 04, 2013		

Freq. (MHz)	Level (dBuV)	Over Limit (dB)	Limit Line (dBuV)	Remark
-	-	-	-	See Note

Note:

The amplitude of spurious emissions that are attenuated by more than 20 dB below the permissible value has no need to be reported.

Distance extrapolation factor = $40 \log (\text{specific distance} / \text{test distance})$ (dB);

Limit line = specific limits (dBuV) + distance extrapolation factor.

4.5.8. Results of Radiated Emissions (30MHz~1GHz)

Temperature	26°C	Humidity	60%
Test Engineer	Jim Huang	Configurations	Normal Link

Horizontal

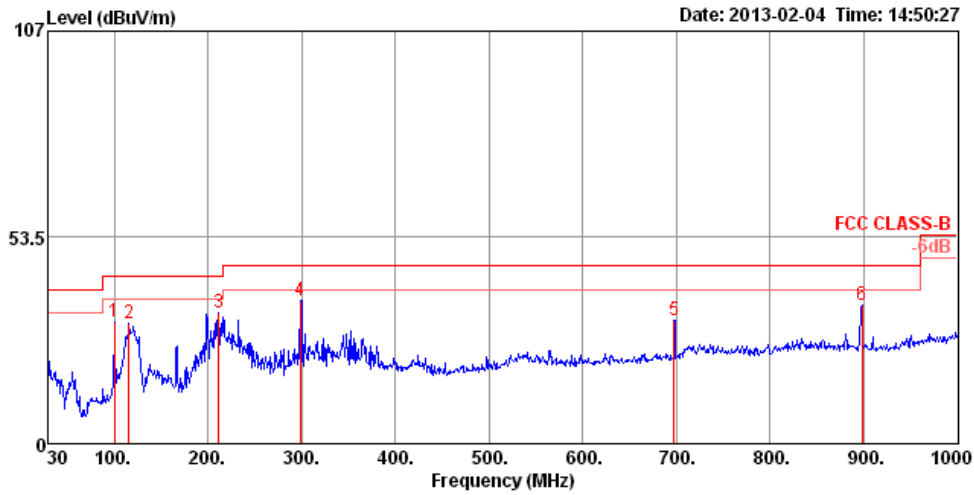

	Freq	Level	Limit Line	Over Limit	Read Level	Cable Loss	Antenna Factor	Preamp Factor	A/Pos	T/Pos	Pol/Phase	Remark
	MHz	dBuV/m	dBuV/m	dB	dBuV	dB	dB/m	dB	cm	deg		
1	99.84	31.58	43.50	-11.92	51.70	1.18	10.31	31.61	300	345	HORIZONTAL	Peak
2	115.36	31.02	43.50	-12.48	49.81	1.27	11.49	31.55	300	360	HORIZONTAL	Peak
3	211.39	33.77	43.50	-9.73	54.97	1.78	8.44	31.42	125	326	HORIZONTAL	Peak
4 pp	298.69	37.17	46.00	-8.83	53.50	2.12	12.98	31.43	100	175	HORIZONTAL	Peak
5	697.36	32.16	46.00	-13.84	41.18	3.40	18.89	31.31	150	66	HORIZONTAL	Peak
6	898.15	35.77	46.00	-10.23	42.37	3.97	20.63	31.20	100	262	HORIZONTAL	Peak

Vertical

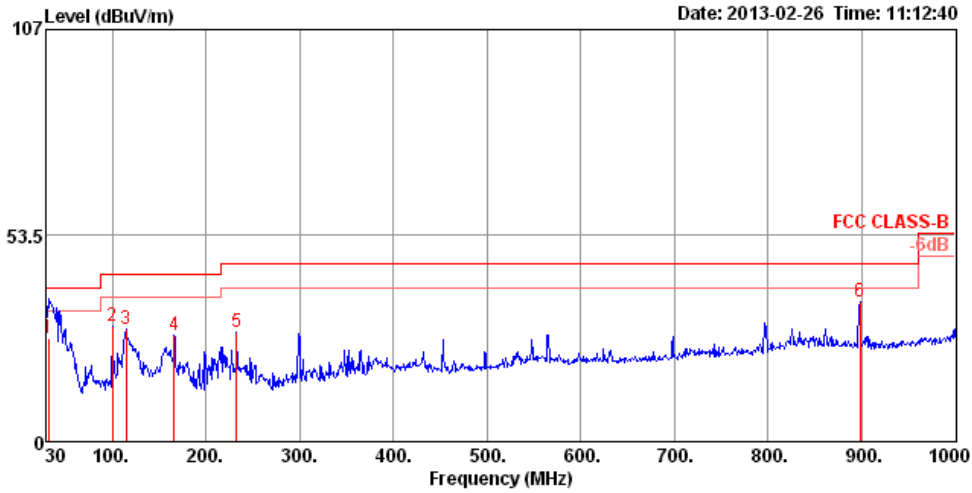

	Freq	Level	Limit	Over	Read	CableAntenna	Preamp	A/Pos	T/Pos	Pol/Phase	Remark	
	MHz	dBuV/m	dBuV/m	dB	dBuV	dB	dB/m	dB	cm	deg		
1	qp	31.94	27.03	40.00	-12.97	41.30	0.66	16.91	31.84	100	65 VERTICAL	QP
2		99.84	30.12	43.50	-13.38	50.24	1.18	10.31	31.61	100	12 VERTICAL	Peak
3		114.39	29.37	43.50	-14.13	48.18	1.27	11.47	31.55	100	190 VERTICAL	Peak
4		165.80	27.78	43.50	-15.72	48.38	1.56	9.38	31.54	100	1 VERTICAL	Peak
5		232.73	28.40	46.00	-17.60	47.99	1.84	10.02	31.45	100	202 VERTICAL	Peak
6	pp	898.15	36.39	46.00	-9.61	42.99	3.97	20.63	31.20	125	358 VERTICAL	Peak

Note:

The amplitude of spurious emissions that are attenuated by more than 20dB below the permissible value has no need to be reported.

Emission level (dBuV/m) = 20 log Emission level (uV/m).

Corrected Reading: Antenna Factor + Cable Loss + Read Level - Preamp Factor = Level.

4.5.9. Results for Radiated Emissions (1GHz~10th Harmonic)

Temperature	25.6°C	Humidity	56%
Test Engineer	Andre Tak	Configurations	IEEE 802.11n MCS0 20MHz Ch 1 / Chain 1 + Chain 2 (2TX)
Test Date	Jan. 31, 2013		

Horizontal

	Freq	Level	Limit Line	Over Limit	Read Level	Cable Loss	Antenna Factor	Preamp Factor	Remark	A/Pos	T/Pos	PoI/Phase
	MHz	dBuV/m	dBuV/m	dB	dBuV	dB	dB/m	dB		cm	deg	
1	2287.98	43.41	54.00	-10.59	48.40	2.17	27.94	35.10	Average	99	353	HORIZONTAL
2	2287.98	48.39	74.00	-25.61	53.38	2.17	27.94	35.10	Peak	99	353	HORIZONTAL
3	4824.00	29.04	54.00	-24.96	27.70	3.31	33.06	35.03	Average	100	298	HORIZONTAL
4	4824.00	38.84	74.00	-35.16	37.50	3.31	33.06	35.03	Peak	100	298	HORIZONTAL

Vertical

	Freq	Level	Limit Line	Over Limit	Read Level	Cable Loss	Antenna Factor	Preamp Factor	Remark	A/Pos	T/Pos	PoI/Phase
	MHz	dBuV/m	dBuV/m	dB	dBuV	dB	dB/m	dB		cm	deg	
1	2287.99	52.95	54.00	-1.05	57.94	2.17	27.94	35.10	Average	100	326	VERTICAL
2	2287.99	56.94	74.00	-17.06	61.93	2.17	27.94	35.10	Peak	100	326	VERTICAL
3	4824.00	29.28	54.00	-24.72	27.94	3.31	33.06	35.03	Average	100	247	VERTICAL
4	4824.00	39.86	74.00	-34.14	38.52	3.31	33.06	35.03	Peak	100	247	VERTICAL



Temperature	25.6°C	Humidity	56%
Test Engineer	Andre Tak	Configurations	IEEE 802.11n MCS0 20MHz Ch 6 / Chain 1 + Chain 2 (2TX)
Test Date	Jan. 31, 2013		

Horizontal

	Freq	Level	Limit Line	Over Limit	Read Level	CableAntenna Loss	Antenna Factor	Preamp Factor	Remark	A/Pos	T/Pos	Pol/Phase
	MHz	dBuV/m	dBuV/m	dB	dBuV	dB	dB/m	dB		cm	deg	
1	2288.03	45.06	54.00	-8.94	50.05	2.17	27.94	35.10	Average	100	216	HORIZONTAL
2	2288.03	48.23	74.00	-25.77	53.22	2.17	27.94	35.10	Peak	100	216	HORIZONTAL
3	4874.00	28.35	54.00	-25.65	26.89	3.33	33.16	35.03	Average	100	306	HORIZONTAL
4	4874.00	39.19	74.00	-34.81	37.73	3.33	33.16	35.03	Peak	100	306	HORIZONTAL

Vertical

	Freq	Level	Limit Line	Over Limit	Read Level	CableAntenna Loss	Antenna Factor	Preamp Factor	Remark	A/Pos	T/Pos	Pol/Phase
	MHz	dBuV/m	dBuV/m	dB	dBuV	dB	dB/m	dB		cm	deg	
1	2287.98	53.16	54.00	-0.84	58.15	2.17	27.94	35.10	Average	100	329	VERTICAL
2	2287.98	56.15	74.00	-17.85	61.14	2.17	27.94	35.10	Peak	100	329	VERTICAL
3	4874.00	28.78	54.00	-25.22	27.32	3.33	33.16	35.03	Average	100	263	VERTICAL
4	4874.00	40.44	74.00	-33.56	38.98	3.33	33.16	35.03	Peak	100	263	VERTICAL



Temperature	25.6°C	Humidity	56%
Test Engineer	Andre Tak	Configurations	IEEE 802.11n MCS0 20MHz Ch 11 / Chain 1 + Chain 2 (2TX)
Test Date	Jan. 31, 2013		

Horizontal

	Freq	Level	Limit Line	Over Limit	Read Level	CableAntenna Loss	Antenna Factor	Preamp Factor	Remark	A/Pos	T/Pos	Pol/Phase
	MHz	dBuV/m	dBuV/m	dB	dBuV	dB	dB/m	dB		cm	deg	
1	2287.98	49.58	74.00	-24.42	54.57	2.17	27.94	35.10	Peak	100	352	HORIZONTAL
2	2287.99	44.59	54.00	-9.41	49.58	2.17	27.94	35.10	Average	100	352	HORIZONTAL
3	4924.00	29.87	54.00	-24.13	28.27	3.35	33.26	35.01	Average	100	305	HORIZONTAL
4	4924.00	41.39	74.00	-32.61	39.79	3.35	33.26	35.01	Peak	100	305	HORIZONTAL

Vertical

	Freq	Level	Limit Line	Over Limit	Read Level	CableAntenna Loss	Antenna Factor	Preamp Factor	Remark	A/Pos	T/Pos	Pol/Phase
	MHz	dBuV/m	dBuV/m	dB	dBuV	dB	dB/m	dB		cm	deg	
1	2287.99	53.62	54.00	-0.38	58.61	2.17	27.94	35.10	Average	100	325	VERTICAL
2	2287.99	57.64	74.00	-16.36	62.63	2.17	27.94	35.10	Peak	100	325	VERTICAL
3	4924.00	30.82	54.00	-23.18	29.22	3.35	33.26	35.01	Average	100	228	VERTICAL
4	4924.00	40.89	74.00	-33.11	39.29	3.35	33.26	35.01	Peak	100	228	VERTICAL

Temperature	25.6°C	Humidity	56%
Test Engineer	Andre Tak	Configurations	IEEE 802.11n MCS0 40MHz Ch 3 / Chain 1 + Chain 2 (2TX)
Test Date	Jan. 31, 2013		

Horizontal

	Freq	Level	Limit Line	Over Limit	Read Level	CableAntenna Loss	Antenna Factor	Preamp Factor	Remark	A/Pos	T/Pos	Pol/Phase
	MHz	dBuV/m	dBuV/m	dB	dBuV	dB	dB/m	dB		cm	deg	
1	2287.98	48.25	74.00	-25.75	53.24	2.17	27.94	35.10	Peak	100	263	HORIZONTAL
2	2288.00	43.49	54.00	-10.51	48.48	2.17	27.94	35.10	Average	100	263	HORIZONTAL
3	4844.00	28.64	54.00	-25.36	27.26	3.32	33.09	35.03	Average	100	191	HORIZONTAL
4	4844.00	40.05	74.00	-33.95	38.67	3.32	33.09	35.03	Peak	100	191	HORIZONTAL

Vertical

	Freq	Level	Limit Line	Over Limit	Read Level	CableAntenna Loss	Antenna Factor	Preamp Factor	Remark	A/Pos	T/Pos	Pol/Phase
	MHz	dBuV/m	dBuV/m	dB	dBuV	dB	dB/m	dB		cm	deg	
1	2287.98	57.39	74.00	-16.61	62.38	2.17	27.94	35.10	Peak	100	329	VERTICAL
2	2287.99	53.20	54.00	-0.80	58.19	2.17	27.94	35.10	Average	100	329	VERTICAL
3	4844.01	29.02	54.00	-24.98	27.64	3.32	33.09	35.03	Average	100	275	VERTICAL
4	4844.01	40.32	74.00	-33.68	38.94	3.32	33.09	35.03	Peak	100	275	VERTICAL



Temperature	25.6°C	Humidity	56%
Test Engineer	Andre Tak	Configurations	IEEE 802.11n MCS0 40MHz Ch 6 / Chain 1 + Chain 2 (2TX)
Test Date	Jan. 31, 2013		

Horizontal

	Freq	Level	Limit Line	Over Limit	Read Level	CableAntenna Loss	Antenna Factor	Preamp Factor	Remark	A/Pos	T/Pos	Pol/Phase
	MHz	dBuV/m	dBuV/m	dB	dBuV	dB	dB/m	dB		cm	deg	
1	2288.00	43.67	54.00	-10.33	48.66	2.17	27.94	35.10	Average	101	201	HORIZONTAL
2	2288.00	47.10	74.00	-26.90	52.09	2.17	27.94	35.10	Peak	101	201	HORIZONTAL
3	4874.00	28.04	54.00	-25.96	26.58	3.33	33.16	35.03	Average	101	119	HORIZONTAL
4	4874.00	40.81	74.00	-33.19	39.35	3.33	33.16	35.03	Peak	101	119	HORIZONTAL

Vertical

	Freq	Level	Limit Line	Over Limit	Read Level	CableAntenna Loss	Antenna Factor	Preamp Factor	Remark	A/Pos	T/Pos	Pol/Phase
	MHz	dBuV/m	dBuV/m	dB	dBuV	dB	dB/m	dB		cm	deg	
1	2287.98	53.74	54.00	-0.26	58.73	2.17	27.94	35.10	Average	100	326	VERTICAL
2	2287.98	56.96	74.00	-17.04	61.95	2.17	27.94	35.10	Peak	100	326	VERTICAL
3	4874.00	28.90	54.00	-25.10	27.44	3.33	33.16	35.03	Average	100	265	VERTICAL
4	4874.00	39.39	74.00	-34.61	37.93	3.33	33.16	35.03	Peak	100	265	VERTICAL

Temperature	25.6°C	Humidity	56%
Test Engineer	Andre Tak	Configurations	IEEE 802.11n MCS0 40MHz Ch 9 / Chain 1 + Chain 2 (2TX)
Test Date	Jan. 31, 2013		

Horizontal

	Freq	Level	Limit Line	Over Limit	Read Level	Cable Loss	Antenna Factor	Preamp Factor	Remark	A/Pos	T/Pos	Pol/Phase
	MHz	dBuV/m	dBuV/m	dB	dBuV	dB	dB/m	dB		cm	deg	
1	2287.98	42.61	54.00	-11.39	47.60	2.17	27.94	35.10	Average	101	201	HORIZONTAL
2	2288.10	47.27	74.00	-26.73	52.26	2.17	27.94	35.10	Peak	101	201	HORIZONTAL
3	4904.00	28.86	54.00	-25.14	27.35	3.34	33.19	35.02	Average	101	140	HORIZONTAL
4	4904.00	39.92	74.00	-34.08	38.41	3.34	33.19	35.02	Peak	101	140	HORIZONTAL

Vertical

	Freq	Level	Limit Line	Over Limit	Read Level	Cable Loss	Antenna Factor	Preamp Factor	Remark	A/Pos	T/Pos	Pol/Phase
	MHz	dBuV/m	dBuV/m	dB	dBuV	dB	dB/m	dB		cm	deg	
1	2288.00	52.65	54.00	-1.35	57.64	2.17	27.94	35.10	Average	101	327	VERTICAL
2	2288.00	55.60	74.00	-18.40	60.59	2.17	27.94	35.10	Peak	101	327	VERTICAL
3	4904.01	28.88	54.00	-25.12	27.37	3.34	33.19	35.02	Average	101	241	VERTICAL
4	4904.01	41.08	74.00	-32.92	39.57	3.34	33.19	35.02	Peak	101	241	VERTICAL



Temperature	25.6°C	Humidity	56%
Test Engineer	Andre Tak	Configurations	IEEE 802.11n MCS0 20MHz Ch 149 / Chain 1 + Chain 2 (2TX)
Test Date	Jan. 31, 2013		

Horizontal

	Freq	Level	Limit	Over	Read	Cable	Antenna	Preamp	Remark	A/Pos	T/Pos	Pol/Phase
	MHz	dBuV/m	dBuV/m	dB	dBuV	dB	dB/m	dB		cm	deg	
1	4999.96	43.87	74.00	-30.13	42.10	3.39	33.39	35.01	Peak	101	139	HORIZONTAL
2	4999.98	38.30	54.00	-15.70	36.53	3.39	33.39	35.01	Average	101	139	HORIZONTAL
3	11491.76	50.04	74.00	-23.96	41.43	5.11	38.78	35.28	Peak	100	30	HORIZONTAL
4	11493.00	37.90	54.00	-16.10	29.29	5.11	38.78	35.28	Average	100	30	HORIZONTAL

Vertical

	Freq	Level	Limit	Over	Read	Cable	Antenna	Preamp	Remark	A/Pos	T/Pos	Pol/Phase
	MHz	dBuV/m	dBuV/m	dB	dBuV	dB	dB/m	dB		cm	deg	
1	4999.01	48.94	54.00	-5.06	47.16	3.39	33.40	35.01	Average	103	62	VERTICAL
2	4999.04	54.72	74.00	-19.28	52.94	3.39	33.40	35.01	Peak	103	62	VERTICAL
3	11486.48	56.07	74.00	-17.93	47.46	5.11	38.78	35.28	Peak	122	199	VERTICAL
4	11486.92	43.50	54.00	-10.50	34.89	5.11	38.78	35.28	Average	122	199	VERTICAL

Temperature	25.6°C	Humidity	56%
Test Engineer	Andre Tak	Configurations	IEEE 802.11n MCS0 20MHz Ch 157 / Chain 1 + Chain 2 (2TX)
Test Date	Jan. 31, 2013		

Horizontal

	Freq	Level	Limit Line	Over Limit	Read Level	CableAntenna Loss	Antenna Factor	Preamp Factor	Remark	A/Pos	T/Pos	Pol/Phase
	MHz	dBuV/m	dBuV/m	dB	dBuV	dB	dB/m	dB		cm	deg	
1	4999.11	48.19	74.00	-25.81	46.42	3.39	33.39	35.01	Peak	100	135	HORIZONTAL
2	4999.96	41.02	54.00	-12.98	39.25	3.39	33.39	35.01	Average	100	135	HORIZONTAL
3	11568.32	37.86	54.00	-16.14	29.20	5.13	38.83	35.30	Average	100	86	HORIZONTAL
4	11576.12	49.44	74.00	-24.56	40.77	5.14	38.83	35.30	Peak	100	86	HORIZONTAL

Vertical

	Freq	Level	Limit Line	Over Limit	Read Level	CableAntenna Loss	Antenna Factor	Preamp Factor	Remark	A/Pos	T/Pos	Pol/Phase
	MHz	dBuV/m	dBuV/m	dB	dBuV	dB	dB/m	dB		cm	deg	
1	4999.92	58.12	74.00	-15.88	56.34	3.39	33.40	35.01	Peak	100	61	VERTICAL
2	4999.96	52.12	54.00	-1.88	50.34	3.39	33.40	35.01	Average	100	61	VERTICAL
3	11562.08	41.50	54.00	-12.50	32.85	5.13	38.82	35.30	Average	106	194	VERTICAL
4	11568.80	55.61	74.00	-18.39	46.95	5.13	38.83	35.30	Peak	106	194	VERTICAL

Temperature	25.6°C	Humidity	56%
Test Engineer	Andre Tak	Configurations	IEEE 802.11n MCS0 20MHz Ch 165 / Chain 1 + Chain 2 (2TX)
Test Date	Jan. 31, 2013		

Horizontal

	Freq	Level	Limit	Over	Read	CableAntenna	Preamp	Remark	A/Pos	T/Pos	PoI/Phase
	MHz	dBuV/m	dBuV/m	dB	dBuV	dB	dB/m	dB	cm	deg	
1	4999.98	41.97	54.00	-12.03	40.20	3.39	33.39	35.01	Average	100	140 HORIZONTAL
2	4999.98	48.23	74.00	-25.77	46.46	3.39	33.39	35.01	Peak	100	140 HORIZONTAL
3	11642.74	37.64	54.00	-16.36	28.92	5.16	38.86	35.30	Average	100	87 HORIZONTAL
4	11652.70	49.65	74.00	-24.35	40.93	5.16	38.86	35.30	Peak	100	87 HORIZONTAL

Vertical

	Freq	Level	Limit	Over	Read	CableAntenna	Preamp	Remark	A/Pos	T/Pos	PoI/Phase
	MHz	dBuV/m	dBuV/m	dB	dBuV	dB	dB/m	dB	cm	deg	
1	4999.93	58.96	74.00	-15.04	57.18	3.39	33.40	35.01	Peak	100	62 VERTICAL
2	4999.97	52.52	54.00	-1.48	50.74	3.39	33.40	35.01	Average	100	62 VERTICAL
3	11640.40	52.89	74.00	-21.11	44.17	5.16	38.86	35.30	Peak	101	222 VERTICAL
4	11644.24	41.37	54.00	-12.63	32.65	5.16	38.86	35.30	Average	101	222 VERTICAL



Temperature	25.6°C	Humidity	56%
Test Engineer	Andre Tak	Configurations	IEEE 802.11n MCS0 40MHz Ch 151 / Chain 1 + Chain 2 (2TX)
Test Date	Jan. 31, 2013		

Horizontal

	Freq	Level	Limit Line	Over Limit	Read Level	CableAntenna Loss	Antenna Factor	Preamp Factor	Remark	A/Pos	T/Pos	PoI/Phase
	MHz	dBuV/m	dBuV/m	dB	dBuV	dB	dB/m	dB		cm	deg	
1	4999.99	38.35	54.00	-15.65	36.58	3.39	33.39	35.01	Average	100	88	HORIZONTAL
2	5000.01	45.01	74.00	-28.99	43.24	3.39	33.39	35.01	Peak	100	88	HORIZONTAL
3	11502.80	37.38	54.00	-16.62	28.75	5.12	38.79	35.28	Average	100	117	HORIZONTAL
4	11529.90	50.36	74.00	-23.64	41.72	5.13	38.80	35.29	Peak	100	117	HORIZONTAL

Vertical

	Freq	Level	Limit Line	Over Limit	Read Level	CableAntenna Loss	Antenna Factor	Preamp Factor	Remark	A/Pos	T/Pos	PoI/Phase
	MHz	dBuV/m	dBuV/m	dB	dBuV	dB	dB/m	dB		cm	deg	
1	4999.97	48.54	54.00	-5.46	46.76	3.39	33.40	35.01	Average	101	66	VERTICAL
2	5000.01	53.12	74.00	-20.88	51.34	3.39	33.40	35.01	Peak	101	66	VERTICAL
3	11508.00	39.19	54.00	-14.81	30.56	5.12	38.79	35.28	Average	114	201	VERTICAL
4	11523.30	51.71	74.00	-22.29	43.07	5.13	38.80	35.29	Peak	114	201	VERTICAL



Temperature	25.6°C	Humidity	56%
Test Engineer	Andre Tak	Configurations	IEEE 802.11n MCS0 40MHz Ch 159 / Chain 1 + Chain 2 (2TX)
Test Date	Jan. 31, 2013		

Horizontal

	Freq	Level	Limit	Over	Read	Cable	Antenna	Preamp	Remark	A/Pos	T/Pos	Pol/Phase
	MHz	dBuV/m	dBuV/m	dB	dBuV	dB	dB/m	dB		cm	deg	
1	4999.94	48.52	74.00	-25.48	46.75	3.39	33.39	35.01	Peak	100	146	HORIZONTAL
2	5000.01	41.56	54.00	-12.44	39.79	3.39	33.39	35.01	Average	100	146	HORIZONTAL
3	11589.95	49.53	74.00	-24.47	40.86	5.14	38.83	35.30	Peak	100	98	HORIZONTAL
4	11590.66	36.76	54.00	-17.24	28.09	5.14	38.83	35.30	Average	100	98	HORIZONTAL

Vertical

	Freq	Level	Limit	Over	Read	Cable	Antenna	Preamp	Remark	A/Pos	T/Pos	Pol/Phase
	MHz	dBuV/m	dBuV/m	dB	dBuV	dB	dB/m	dB		cm	deg	
1	4999.95	57.90	74.00	-16.10	56.12	3.39	33.40	35.01	Peak	100	67	VERTICAL
2	4999.96	52.39	54.00	-1.61	50.61	3.39	33.40	35.01	Average	100	67	VERTICAL
3	11581.80	40.96	54.00	-13.04	32.29	5.14	38.83	35.30	Average	100	203	VERTICAL
4	11600.90	52.55	74.00	-21.45	43.87	5.15	38.83	35.30	Peak	100	203	VERTICAL

Temperature	25.6°C	Humidity	56%
Test Engineer	Andre Tak	Configurations	IEEE 802.11b Ch 1 / Chain 1 (1TX)
Test Date	Jan. 31, 2013		

Horizontal

	Freq	Level	Limit	Over	Read	Cable	Antenna	Preamp	Remark	A/Pos	T/Pos	Pol/Phase
	MHz	dBuV/m	dBuV/m	dB	dBuV	Loss	Factor	Factor		cm	deg	
1	2287.98	43.21	54.00	-10.79	48.20	2.17	27.94	35.10	Average	100	126	HORIZONTAL
2	2288.09	49.69	74.00	-24.31	54.68	2.17	27.94	35.10	Peak	100	126	HORIZONTAL
3	4823.97	37.24	54.00	-16.76	35.90	3.31	33.06	35.03	Average	101	140	HORIZONTAL
4	4823.97	44.16	74.00	-29.84	42.82	3.31	33.06	35.03	Peak	101	140	HORIZONTAL

Vertical

	Freq	Level	Limit	Over	Read	Cable	Antenna	Preamp	Remark	A/Pos	T/Pos	Pol/Phase
	MHz	dBuV/m	dBuV/m	dB	dBuV	Loss	Factor	Factor		cm	deg	
1	2288.02	52.56	54.00	-1.44	57.55	2.17	27.94	35.10	Average	100	321	VERTICAL
2	2288.02	58.59	74.00	-15.41	63.58	2.17	27.94	35.10	Peak	100	321	VERTICAL
3	4824.00	46.72	54.00	-7.28	45.38	3.31	33.06	35.03	Average	104	191	VERTICAL
4	4824.02	49.85	74.00	-24.15	48.51	3.31	33.06	35.03	Peak	104	191	VERTICAL

Temperature	25.6°C	Humidity	56%
Test Engineer	Andre Tak	Configurations	IEEE 802.11b Ch 6 / Chain 1 (1TX)
Test Date	Jan. 31, 2013		

Horizontal

	Freq	Level	Limit	Over	Read	Cable	Antenna	Preamp	Remark	A/Pos	T/Pos	Pol/Phase
	MHz	dBuV/m	dBuV/m	dB	dBuV	Loss	Factor	Factor		cm	deg	
1	2287.97	48.70	74.00	-25.30	53.69	2.17	27.94	35.10	Peak	100	128	HORIZONTAL
2	2287.99	43.70	54.00	-10.30	48.69	2.17	27.94	35.10	Average	100	128	HORIZONTAL
3	4873.97	35.62	54.00	-18.38	34.16	3.33	33.16	35.03	Average	100	204	HORIZONTAL
4	4874.00	43.88	74.00	-30.12	42.42	3.33	33.16	35.03	Peak	100	204	HORIZONTAL

Vertical

	Freq	Level	Limit	Over	Read	Cable	Antenna	Preamp	Remark	A/Pos	T/Pos	Pol/Phase
	MHz	dBuV/m	dBuV/m	dB	dBuV	Loss	Factor	Factor		cm	deg	
1	2287.99	53.59	54.00	-0.41	58.58	2.17	27.94	35.10	Average	100	321	VERTICAL
2	2288.08	57.95	74.00	-16.05	62.94	2.17	27.94	35.10	Peak	100	321	VERTICAL
3	4873.98	49.84	74.00	-24.16	48.38	3.33	33.16	35.03	Peak	101	192	VERTICAL
4	4873.98	46.62	54.00	-7.38	45.16	3.33	33.16	35.03	Average	101	192	VERTICAL

Temperature	25.6°C	Humidity	56%
Test Engineer	Andre Tak	Configurations	IEEE 802.11b Ch 11 / Chain 1 (ITX)
Test Date	Jan. 31, 2013		

Horizontal

	Freq	Level	Limit	Over	Read	Cable	Antenna	Preamp	Remark	A/Pos	T/Pos	Pol/Phase
	MHz	dBuV/m	dBuV/m	dB	dBuV	Loss	Factor	Factor		cm	deg	
1	2288.00	44.31	54.00	-9.69	49.30	2.17	27.94	35.10	Average	101	264	HORIZONTAL
2	2288.01	49.99	74.00	-24.01	54.98	2.17	27.94	35.10	Peak	101	264	HORIZONTAL
3	4923.98	47.15	74.00	-26.85	45.55	3.35	33.26	35.01	Peak	100	234	HORIZONTAL
4	4923.99	40.17	54.00	-13.83	38.57	3.35	33.26	35.01	Average	100	234	HORIZONTAL

Vertical

	Freq	Level	Limit	Over	Read	Cable	Antenna	Preamp	Remark	A/Pos	T/Pos	Pol/Phase
	MHz	dBuV/m	dBuV/m	dB	dBuV	Loss	Factor	Factor		cm	deg	
1	2287.98	53.88	54.00	-0.12	58.87	2.17	27.94	35.10	Average	100	325	VERTICAL
2	2287.98	59.41	74.00	-14.59	64.40	2.17	27.94	35.10	Peak	100	325	VERTICAL
3	4923.97	50.66	54.00	-3.34	49.06	3.35	33.26	35.01	Average	102	192	VERTICAL
4	4923.97	53.00	74.00	-21.00	51.40	3.35	33.26	35.01	Peak	102	192	VERTICAL

Temperature	25.6°C	Humidity	56%
Test Engineer	Andre Tak	Configurations	IEEE 802.11g Ch 1 / Chain 1 + Chain 2 (2TX)
Test Date	Jan. 31, 2013		

Horizontal

	Freq	Level	Limit Line	Over Limit	Read Level	Cable Loss	Antenna Factor	Preamp Factor	Remark	A/Pos	T/Pos	Pol/Phase
	MHz	dBuV/m	dBuV/m	dB	dBuV	dB	dB/m	dB		cm	deg	
1	2287.99	43.51	54.00	-10.49	48.50	2.17	27.94	35.10	Average	100	350	HORIZONTAL
2	2288.05	48.95	74.00	-25.05	53.94	2.17	27.94	35.10	Peak	100	350	HORIZONTAL
3	4824.00	28.75	54.00	-25.25	27.41	3.31	33.06	35.03	Average	100	286	HORIZONTAL
4	4824.00	40.22	74.00	-33.78	38.88	3.31	33.06	35.03	Peak	100	286	HORIZONTAL

Vertical

	Freq	Level	Limit Line	Over Limit	Read Level	Cable Loss	Antenna Factor	Preamp Factor	Remark	A/Pos	T/Pos	Pol/Phase
	MHz	dBuV/m	dBuV/m	dB	dBuV	dB	dB/m	dB		cm	deg	
1	2287.98	53.62	54.00	-0.38	58.61	2.17	27.94	35.10	Average	100	326	VERTICAL
2	2287.98	58.76	74.00	-15.24	63.75	2.17	27.94	35.10	Peak	100	326	VERTICAL
3	4824.00	29.51	54.00	-24.49	28.17	3.31	33.06	35.03	Average	100	232	VERTICAL
4	4824.00	41.40	74.00	-32.60	40.06	3.31	33.06	35.03	Peak	100	232	VERTICAL

Temperature	25.6°C	Humidity	56%
Test Engineer	Andre Tak	Configurations	IEEE 802.11g Ch 6 / Chain 1 + Chain 2 (2TX)
Test Date	Jan. 31, 2013		

Horizontal

	Freq	Level	Limit	Over	Read	CableAntenna	Preamp	Remark	A/Pos	T/Pos	Pol/Phase
	MHz	dBuV/m	dBuV/m	dB	dBuV	dB	dB/m	dB	cm	deg	
1	2287.99	43.45	54.00	-10.55	48.44	2.17	27.94	35.10	Average	100	351 HORIZONTAL
2	2287.99	48.13	74.00	-25.87	53.12	2.17	27.94	35.10	Peak	100	351 HORIZONTAL
3	4874.01	28.56	54.00	-25.44	27.10	3.33	33.16	35.03	Average	100	290 HORIZONTAL
4	4874.01	40.31	74.00	-33.69	38.85	3.33	33.16	35.03	Peak	100	290 HORIZONTAL

Vertical

	Freq	Level	Limit	Over	Read	CableAntenna	Preamp	Remark	A/Pos	T/Pos	Pol/Phase
	MHz	dBuV/m	dBuV/m	dB	dBuV	dB	dB/m	dB	cm	deg	
1	2287.99	53.03	54.00	-0.97	58.02	2.17	27.94	35.10	Average	100	326 VERTICAL
2	2288.01	56.98	74.00	-17.02	61.97	2.17	27.94	35.10	Peak	100	326 VERTICAL
3	4874.01	29.04	54.00	-24.96	27.58	3.33	33.16	35.03	Average	100	261 VERTICAL
4	4874.01	40.49	74.00	-33.51	39.03	3.33	33.16	35.03	Peak	100	261 VERTICAL



Temperature	25.6°C	Humidity	56%
Test Engineer	Andre Tak	Configurations	IEEE 802.11g Ch 11 / Chain 1 + Chain 2 (2TX)
Test Date	Jan. 31, 2013		

Horizontal

	Freq	Level	Limit	Over	Read	CableAntenna	Preamp	Remark	A/Pos	T/Pos	Pol/Phase	
	MHz	dBuV/m	dBuV/m	dB	dBuV	dB	dB/m	dB	cm	deg		
1	2287.99	46.26	54.00	-7.74	51.25	2.17	27.94	35.10	Average	151	247	HORIZONTAL
2	2287.99	49.63	74.00	-24.37	54.62	2.17	27.94	35.10	Peak	151	247	HORIZONTAL
3	4924.00	29.69	54.00	-24.31	28.09	3.35	33.26	35.01	Average	100	313	HORIZONTAL
4	4924.00	40.87	74.00	-33.13	39.27	3.35	33.26	35.01	Peak	100	313	HORIZONTAL

Vertical

	Freq	Level	Limit	Over	Read	CableAntenna	Preamp	Remark	A/Pos	T/Pos	Pol/Phase	
	MHz	dBuV/m	dBuV/m	dB	dBuV	dB	dB/m	dB	cm	deg		
1	2287.98	53.75	54.00	-0.25	58.74	2.17	27.94	35.10	Average	100	327	VERTICAL
2	2287.98	57.59	74.00	-16.41	62.58	2.17	27.94	35.10	Peak	100	327	VERTICAL
3	4924.00	31.60	54.00	-22.40	30.00	3.35	33.26	35.01	Average	100	273	VERTICAL
4	4924.00	41.09	74.00	-32.91	39.49	3.35	33.26	35.01	Peak	100	273	VERTICAL

Temperature	25.6°C	Humidity	56%
Test Engineer	Andre Tak	Configurations	IEEE 802.11a Ch 149 / Chain 1 + Chain 2 (2TX)
Test Date	Jan. 31, 2013		

Horizontal

	Freq	Level	Limit	Over	Read	CableAntenna	Preamp	Remark	A/Pos	T/Pos	PoI/Phase
	MHz	dBuV/m	dBuV/m	dB	dBuV	dB	dB/m	dB	cm	deg	
1	4999.92	46.00	74.00	-28.00	44.23	3.39	33.39	35.01	100	143	HORIZONTAL
2	4999.98	37.76	54.00	-16.24	35.99	3.39	33.39	35.01	100	143	HORIZONTAL
3	11493.40	37.98	54.00	-16.02	29.36	5.12	38.78	35.28	100	205	HORIZONTAL
4	11494.20	50.68	74.00	-23.32	42.06	5.12	38.78	35.28	100	205	HORIZONTAL

Vertical

	Freq	Level	Limit	Over	Read	CableAntenna	Preamp	Remark	A/Pos	T/Pos	PoI/Phase
	MHz	dBuV/m	dBuV/m	dB	dBuV	dB	dB/m	dB	cm	deg	
1	4999.95	53.46	74.00	-20.54	51.68	3.39	33.40	35.01	101	64	VERTICAL
2	4999.99	48.37	54.00	-5.63	46.59	3.39	33.40	35.01	101	64	VERTICAL
3	11488.40	42.23	54.00	-11.77	33.62	5.11	38.78	35.28	100	194	VERTICAL
4	11489.40	55.14	74.00	-18.86	46.53	5.11	38.78	35.28	100	194	VERTICAL



Temperature	25.6°C	Humidity	56%
Test Engineer	Andre Tak	Configurations	IEEE 802.11a Ch 157 / Chain 1 + Chain 2 (2TX)
Test Date	Jan. 31, 2013		

Horizontal

	Freq	Level	Limit	Over	Read	CableAntenna	Preamp	Remark	A/Pos	T/Pos	PoI/Phase
	MHz	dBuV/m	dBuV/m	dB	dBuV	dB	dB/m	dB	cm	deg	
1	4999.89	49.17	74.00	-24.83	47.40	3.39	33.39	35.01	Peak	101	84 HORIZONTAL
2	4999.96	42.29	54.00	-11.71	40.52	3.39	33.39	35.01	Average	101	84 HORIZONTAL
3	11567.80	37.39	54.00	-16.61	28.73	5.13	38.83	35.30	Average	100	201 HORIZONTAL
4	11573.40	48.98	74.00	-25.02	40.31	5.14	38.83	35.30	Peak	100	201 HORIZONTAL

Vertical

	Freq	Level	Limit	Over	Read	CableAntenna	Preamp	Remark	A/Pos	T/Pos	PoI/Phase
	MHz	dBuV/m	dBuV/m	dB	dBuV	dB	dB/m	dB	cm	deg	
1	4999.97	51.93	54.00	-2.07	50.15	3.39	33.40	35.01	Average	100	64 VERTICAL
2	5000.00	57.19	74.00	-16.81	55.41	3.39	33.40	35.01	Peak	100	64 VERTICAL
3	11573.20	39.38	54.00	-14.62	30.71	5.14	38.83	35.30	Average	118	191 VERTICAL
4	11578.90	52.26	74.00	-21.74	43.59	5.14	38.83	35.30	Peak	118	191 VERTICAL



Temperature	25.6°C	Humidity	56%
Test Engineer	Andre Tak	Configurations	IEEE 802.11a Ch 165 / Chain 1 + Chain 2 (2TX)
Test Date	Jan. 31, 2013		

Horizontal

	Freq	Level	Limit Line	Over Limit	Read Level	Cable Loss	Antenna Factor	Preamp Factor	Remark	A/Pos	T/Pos	PoI/Phase
	MHz	dBuV/m	dBuV/m	dB	dBuV	dB	dB/m	dB		cm	deg	
1	5000.00	41.20	54.00	-12.80	39.43	3.39	33.39	35.01	Average	100	85	HORIZONTAL
2	5000.00	48.52	74.00	-25.48	46.75	3.39	33.39	35.01	Peak	100	85	HORIZONTAL
3	11652.40	37.19	54.00	-16.81	28.47	5.16	38.86	35.30	Average	100	121	HORIZONTAL
4	11654.90	49.34	74.00	-24.66	40.62	5.16	38.86	35.30	Peak	100	121	HORIZONTAL

Vertical

	Freq	Level	Limit Line	Over Limit	Read Level	Cable Loss	Antenna Factor	Preamp Factor	Remark	A/Pos	T/Pos	PoI/Phase
	MHz	dBuV/m	dBuV/m	dB	dBuV	dB	dB/m	dB		cm	deg	
1	4999.96	57.03	74.00	-16.97	55.25	3.39	33.40	35.01	Peak	100	64	VERTICAL
2	4999.98	52.22	54.00	-1.78	50.44	3.39	33.40	35.01	Average	100	64	VERTICAL
3	11652.00	40.76	54.00	-13.24	32.04	5.16	38.86	35.30	Average	100	33	VERTICAL
4	11652.60	52.81	74.00	-21.19	44.09	5.16	38.86	35.30	Peak	100	33	VERTICAL

Note:

The amplitude of spurious emissions that are attenuated by more than 20dB below the permissible value has no need to be reported.

Emission level (dBuV/m) = 20 log Emission level (uV/m).

Corrected Reading: Antenna Factor + Cable Loss + Read Level - Preamp Factor = Level.

4.6. Emissions Measurement

4.6.1. Limit

30dBc in any 100 kHz bandwidth outside the operating frequency band. In case the emission fall within the restricted band specified on 15.205(a), then the 15.209(a) limit in the table below has to be followed.

Frequencies (MHz)	Field Strength (micorvolts/meter)	Measurement Distance (meters)
0.009~0.490	2400/F(KHz)	300
0.490~1.705	24000/F(KHz)	30
1.705~30.0	30	30
30~88	100	3
88~216	150	3
216~960	200	3
Above 960	500	3

4.6.2. Measuring Instruments and Setting

Please refer to section 5 of equipments list in this report. The following table is the setting of the spectrum analyzer.

Spectrum Parameter	Setting
Attenuation	Auto
Span Frequency	100 MHz
RB / VB (Emission in restricted band)	1MHz / 3MHz for Peak, 1 MHz / 10Hz for Average
RB / VB (Emission in non-restricted band)	100 kHz / 300 kHz for Peak

4.6.3. Test Procedures

For Radiated band edges Measurement:

1. The test procedure is the same as section 4.5.3, only the frequency range investigated is limited to 100MHz around band edges.

For Conducted Out of Band Emission Measurement:

1. Test was performed in accordance with KDB 558074 v02 Guidance for Performing Compliance Measurements on Digital Transmission Systems (DTS) Operating Under §15.247 section 10.1 Unwanted Emissions into Non-Restricted Frequency Bands Measurement Procedure
2. The conducted emission test is performed on each TX port of operating mode without summing or adding 10log (N) since the limit is relative emission limit.

Only worst data of each operating mode is presented.

4.6.4. Test Setup Layout

For Radiated band edges Measurement:

This test setup layout is the same as that shown in section 4.5.4.

For Conducted Out of Band Emission Measurement:

This test setup layout is the same as that shown in section 4.4.4.

4.6.5. Test Deviation

There is no deviation with the original standard.

4.6.6. EUT Operation during Test

The EUT was programmed to be in continuously transmitting mode.

4.6.7. Test Result of Band Edge and Fundamental Emissions

Temperature	25.6°C	Humidity	56%
Test Engineer	Andre Tak	Configurations	IEEE 802.11n MCS0 20MHz Ch 1, 6, 11 / Chain 1 + Chain 2 (2TX)
Test Date	Jan. 30, 2013		

Channel 1

	Freq	Level	Limit Line	Over Limit	Read Level	CableAntenna Loss	Antenna Factor	Preamp Factor	Remark	A/Pos	T/Pos	PoI/Phase
	MHz	dBuV/m	dBuV/m	dB	dBuV	dB	dB/m	dB		cm	deg	
1	2390.00	53.39	54.00	-0.61	23.00	2.22	28.17	0.00	Average	100	30	VERTICAL
2	2390.00	71.69	74.00	-2.31	41.30	2.22	28.17	0.00	Peak	100	30	VERTICAL
3	2415.00	102.45			72.02	2.22	28.21	0.00	Average	100	30	VERTICAL
4	2415.20	111.90			81.47	2.22	28.21	0.00	Peak	100	30	VERTICAL

Item 3, 4 are the fundamental frequency at 2412 MHz.

Channel 6

	Freq	Level	Limit Line	Over Limit	Read Level	CableAntenna Loss	Antenna Factor	Preamp Factor	Remark	A/Pos	T/Pos	PoI/Phase
	MHz	dBuV/m	dBuV/m	dB	dBuV	dB	dB/m	dB		cm	deg	
1	2354.80	60.99	74.00	-13.01	30.70	2.19	28.10	0.00	Peak	100	28	VERTICAL
2	2355.60	49.52	54.00	-4.48	19.23	2.19	28.10	0.00	Average	100	28	VERTICAL
3	2431.00	103.57			73.09	2.23	28.25	0.00	Average	100	28	VERTICAL
4	2431.80	113.95			83.47	2.23	28.25	0.00	Peak	100	28	VERTICAL
5	2483.50	45.42	54.00	-8.58	14.79	2.26	28.37	0.00	Average	100	28	VERTICAL
6	2483.50	56.60	74.00	-17.40	25.97	2.26	28.37	0.00	Peak	100	28	VERTICAL

Item 3, 4 are the fundamental frequency at 2437MHz.

Channel 11

	Freq	Level	Limit Line	Over Limit	Read Level	CableAntenna Loss	Antenna Factor	Preamp Factor	Remark	A/Pos	T/Pos	PoI/Phase
	MHz	dBuV/m	dBuV/m	dB	dBuV	dB	dB/m	dB		cm	deg	
1	2465.40	110.69			80.12	2.24	28.33	0.00	Peak	100	28	VERTICAL
2	2466.00	101.01			70.44	2.24	28.33	0.00	Average	100	28	VERTICAL
3	2483.50	53.12	54.00	-0.88	22.49	2.26	28.37	0.00	Average	100	28	VERTICAL
4	2484.10	72.79	74.00	-1.21	42.16	2.26	28.37	0.00	Peak	100	28	VERTICAL

Item 1, 2 are the fundamental frequency at 2462 MHz.

Temperature	25.6°C	Humidity	56%
Test Engineer	Andre Tak	Configurations	IEEE 802.11n MCS0 40MHz Ch 3, 6, 9 / Chain 1 + Chain 2 (2TX)
Test Date	Jan. 30, 2013		

Channel 3

	Freq	Level	Limit Line	Over Limit	Read Level	CableAntenna Loss	Antenna Factor	Preamp Factor	Remark	A/Pos	T/Pos	Pol/Phase
	MHz	dBuV/m	dBuV/m	dB	dBuV	dB	dB/m	dB		cm	deg	
1	2390.00	53.45	54.00	-0.55	23.06	2.22	28.17	0.00	Average	100	208	VERTICAL
2	2390.00	70.25	74.00	-3.75	39.86	2.22	28.17	0.00	Peak	100	208	VERTICAL
3	2438.00	100.70			70.18	2.23	28.29	0.00	Average	100	208	VERTICAL
4	2438.40	109.94			79.42	2.23	28.29	0.00	Peak	100	208	VERTICAL

Item 3, 4 are the fundamental frequency at 2422 MHz.

Channel 6

	Freq	Level	Limit Line	Over Limit	Read Level	CableAntenna Loss	Antenna Factor	Preamp Factor	Remark	A/Pos	T/Pos	Pol/Phase
	MHz	dBuV/m	dBuV/m	dB	dBuV	dB	dB/m	dB		cm	deg	
1	2390.00	48.14	54.00	-5.86	17.75	2.22	28.17	0.00	Average	100	23	VERTICAL
2	2390.00	63.46	74.00	-10.54	33.07	2.22	28.17	0.00	Peak	100	23	VERTICAL
3	2438.60	109.57			79.05	2.23	28.29	0.00	Peak	100	23	VERTICAL
4	2439.00	100.41			69.89	2.23	28.29	0.00	Average	100	23	VERTICAL
5	2483.50	53.69	54.00	-0.31	23.06	2.26	28.37	0.00	Average	100	23	VERTICAL
6	2483.50	69.09	74.00	-4.91	38.46	2.26	28.37	0.00	Peak	100	23	VERTICAL

Item 3, 4 are the fundamental frequency at 2437MHz.

Channel 9

	Freq	Level	Limit Line	Over Limit	Read Level	CableAntenna Loss	Antenna Factor	Preamp Factor	Remark	A/Pos	T/Pos	Pol/Phase
	MHz	dBuV/m	dBuV/m	dB	dBuV	dB	dB/m	dB		cm	deg	
1	2464.80	98.55			67.98	2.24	28.33	0.00	Average	101	24	VERTICAL
2	2467.60	108.31			77.72	2.26	28.33	0.00	Peak	101	24	VERTICAL
3	2483.50	53.72	54.00	-0.28	23.09	2.26	28.37	0.00	Average	101	24	VERTICAL
4	2483.50	73.28	74.00	-0.72	42.65	2.26	28.37	0.00	Peak	101	24	VERTICAL

Item 1, 2 are the fundamental frequency at 2452 MHz.

Note:

Emission level (dBuV/m) = 20 log Emission level (uV/m).

Corrected Reading: Antenna Factor + Cable Loss + Read Level - Preamp Factor = Level.

Temperature	25.6°C	Humidity	56%
Test Engineer	Andre Tak	Configurations	IEEE 802.11b Ch 1, 6, 11 / Chain 1 (ITX)
Test Date	Jan. 30, 2013		

Channel 1

	Freq	Level	Limit Line	Over Limit	Read Level	CableAntenna Loss	Antenna Factor	Preamp Factor	Remark	A/Pos	T/Pos	Pol/Phase
	MHz	dBuV/m	dBuV/m	dB	dBuV	dB	dB/m	dB		cm	deg	
1	2390.00	53.63	54.00	-0.37	23.24	2.22	28.17	0.00	Average	100	276	VERTICAL
2	2390.00	62.28	74.00	-11.72	31.89	2.22	28.17	0.00	Peak	100	276	VERTICAL
3	2410.20	109.00			78.57	2.22	28.21	0.00	Average	100	276	VERTICAL
4	2411.00	112.74			82.31	2.22	28.21	0.00	Peak	100	276	VERTICAL

Item 3, 4 are the fundamental frequency at 2412 MHz.

Channel 6

	Freq	Level	Limit Line	Over Limit	Read Level	CableAntenna Loss	Antenna Factor	Preamp Factor	Remark	A/Pos	T/Pos	Pol/Phase
	MHz	dBuV/m	dBuV/m	dB	dBuV	dB	dB/m	dB		cm	deg	
1	2350.44	53.62	54.00	-0.38	23.33	2.19	28.10	0.00	Average	100	23	VERTICAL
2	2351.00	62.60	74.00	-11.40	32.31	2.19	28.10	0.00	Peak	100	23	VERTICAL
3	2436.20	112.69			82.17	2.23	28.29	0.00	Peak	100	23	VERTICAL
4	2438.60	108.79			78.27	2.23	28.29	0.00	Average	100	23	VERTICAL
5	2483.50	44.42	54.00	-9.58	13.79	2.26	28.37	0.00	Average	100	23	VERTICAL
6	2483.50	56.07	74.00	-17.93	25.44	2.26	28.37	0.00	Peak	100	23	VERTICAL

Item 3, 4 are the fundamental frequency at 2437 MHz.

Channel 11

	Freq	Level	Limit Line	Over Limit	Read Level	CableAntenna Loss	Antenna Factor	Preamp Factor	Remark	A/Pos	T/Pos	Pol/Phase
	MHz	dBuV/m	dBuV/m	dB	dBuV	dB	dB/m	dB		cm	deg	
1	2460.20	108.28			77.71	2.24	28.33	0.00	Average	100	23	VERTICAL
2	2461.20	111.93			81.36	2.24	28.33	0.00	Peak	100	23	VERTICAL
3	2483.50	52.46	54.00	-1.54	21.83	2.26	28.37	0.00	Average	100	23	VERTICAL
4	2483.50	60.21	74.00	-13.79	29.58	2.26	28.37	0.00	Peak	100	23	VERTICAL

Item 1, 2 are the fundamental frequency at 2462 MHz.

Temperature	25.6°C	Humidity	56%
Test Engineer	Andre Tak	Configurations	IEEE 802.11g Ch 1, 6, 11 / Chain 1 + Chain 2 (2TX)
Test Date	Jan. 30, 2013		

Channel 1

	Freq	Level	Limit Line	Over Limit	Read Level	CableAntenna Loss	Antenna Factor	Preamp Factor	Remark	A/Pos	T/Pos	Pol/Phase
	MHz	dBuV/m	dBuV/m	dB	dBuV	dB	dB/m	dB		cm	deg	
1	2389.20	72.80	74.00	-1.20	42.42	2.21	28.17	0.00	Peak	100	25	VERTICAL
2	2390.00	52.67	54.00	-1.33	22.28	2.22	28.17	0.00	Average	100	25	VERTICAL
3	2410.00	103.19			72.76	2.22	28.21	0.00	Average	100	25	VERTICAL
4	2410.20	113.62			83.19	2.22	28.21	0.00	Peak	100	25	VERTICAL

Item 3, 4 are the fundamental frequency at 2412 MHz.

Channel 6

	Freq	Level	Limit Line	Over Limit	Read Level	CableAntenna Loss	Antenna Factor	Preamp Factor	Remark	A/Pos	T/Pos	Pol/Phase
	MHz	dBuV/m	dBuV/m	dB	dBuV	dB	dB/m	dB		cm	deg	
1	2355.60	50.56	54.00	-3.44	20.27	2.19	28.10	0.00	Average	100	28	VERTICAL
2	2355.60	63.23	74.00	-10.77	32.94	2.19	28.10	0.00	Peak	100	28	VERTICAL
3	2430.20	104.04			73.56	2.23	28.25	0.00	Average	100	28	VERTICAL
4	2430.20	113.98			83.50	2.23	28.25	0.00	Peak	100	28	VERTICAL
5	2483.50	46.74	54.00	-7.26	16.11	2.26	28.37	0.00	Average	100	28	VERTICAL
6	2485.90	59.69	74.00	-14.31	29.02	2.26	28.41	0.00	Peak	100	28	VERTICAL

Item 3, 4 are the fundamental frequency at 2437 MHz.

Channel 11

	Freq	Level	Limit Line	Over Limit	Read Level	CableAntenna Loss	Antenna Factor	Preamp Factor	Remark	A/Pos	T/Pos	Pol/Phase
	MHz	dBuV/m	dBuV/m	dB	dBuV	dB	dB/m	dB		cm	deg	
1	2460.00	103.80			73.23	2.24	28.33	0.00	Average	100	23	VERTICAL
2	2460.20	113.38			82.81	2.24	28.33	0.00	Peak	100	23	VERTICAL
3	2484.50	51.87	54.00	-2.13	21.24	2.26	28.37	0.00	Average	100	23	VERTICAL
4	2484.50	71.30	74.00	-2.70	40.67	2.26	28.37	0.00	Peak	100	23	VERTICAL

Item 1, 2 are the fundamental frequency at 2462 MHz.

For Emission not in Restricted Band

Plot on Configuration IEEE 802.11n MCS0 20MHz / Reference Level

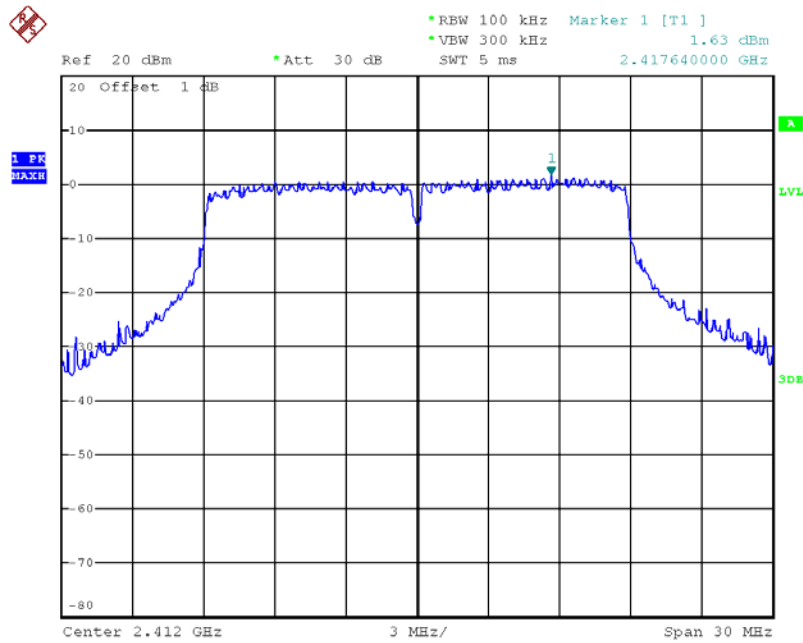

Date: 4.FEB.2013 18:01:35

Plot on Configuration IEEE 802.11n MCS0 20MHz / CH 1 (down 30dBc)

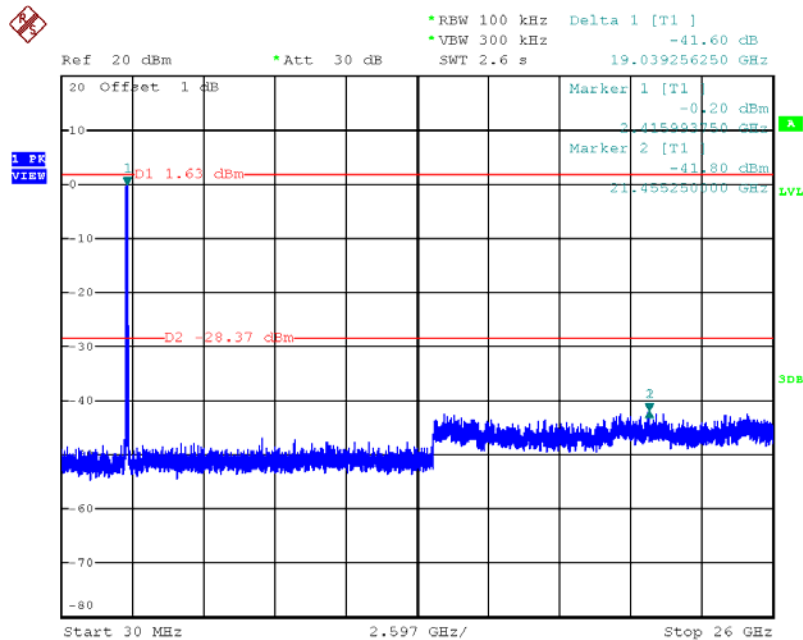

Date: 4.FEB.2013 18:22:03

Plot on Configuration IEEE 802.11n MCS0 20MHz / CH 6 (down 30dBc)

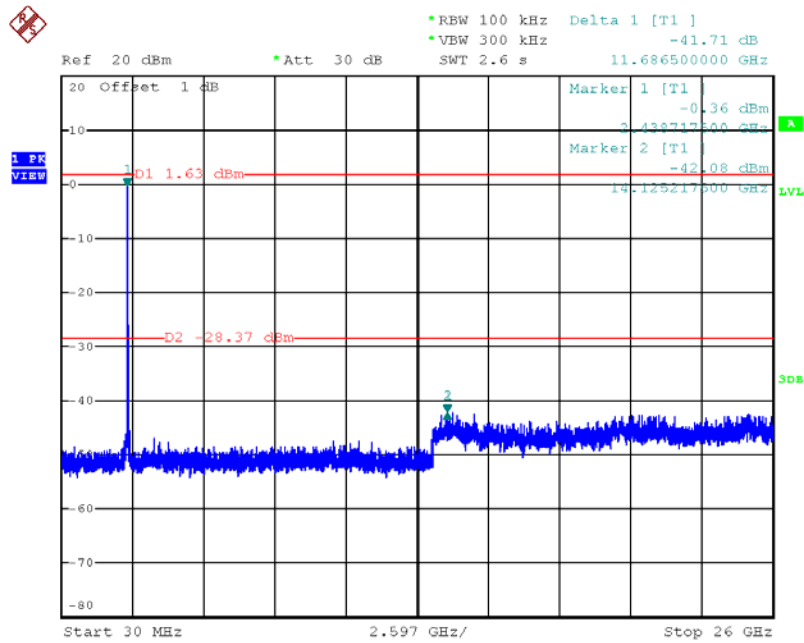

Date: 4.FEB.2013 18:21:02

Plot on Configuration IEEE 802.11n MCS0 20MHz / CH 11 (down 30dBc)

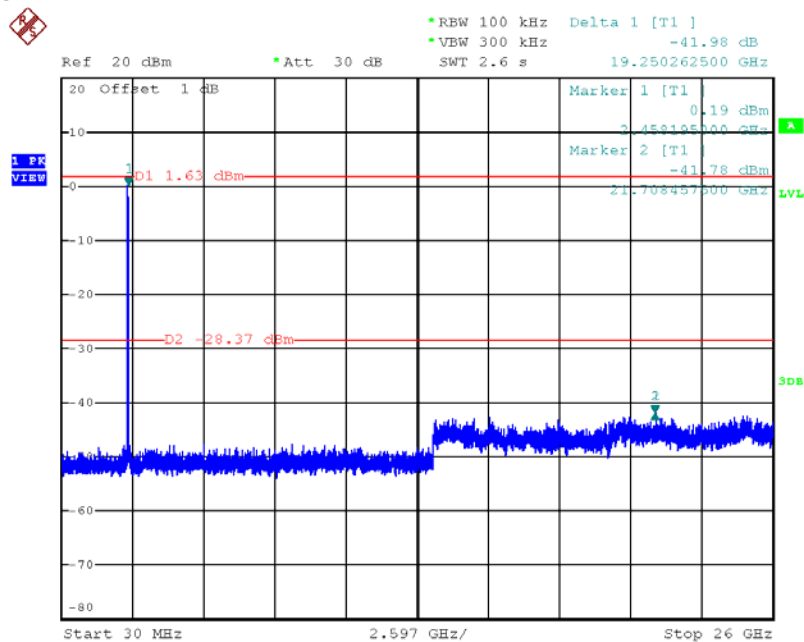

Date: 4.FEB.2013 18:20:29

Plot on Configuration IEEE 802.11n MCS0 40MHz / Reference Level

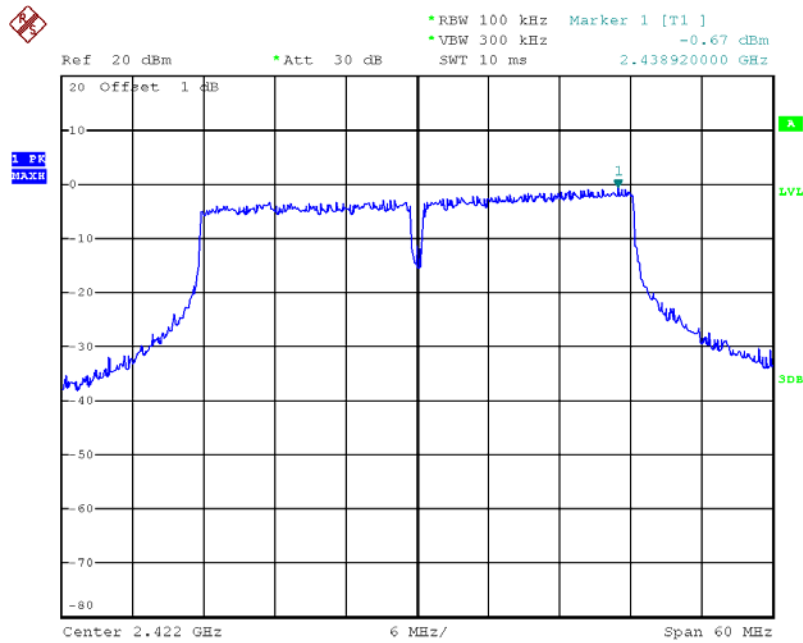

Date: 4.FEB.2013 18:09:19

Plot on Configuration IEEE 802.11n MCS0 40MHz / CH 3 (down 30dBc)

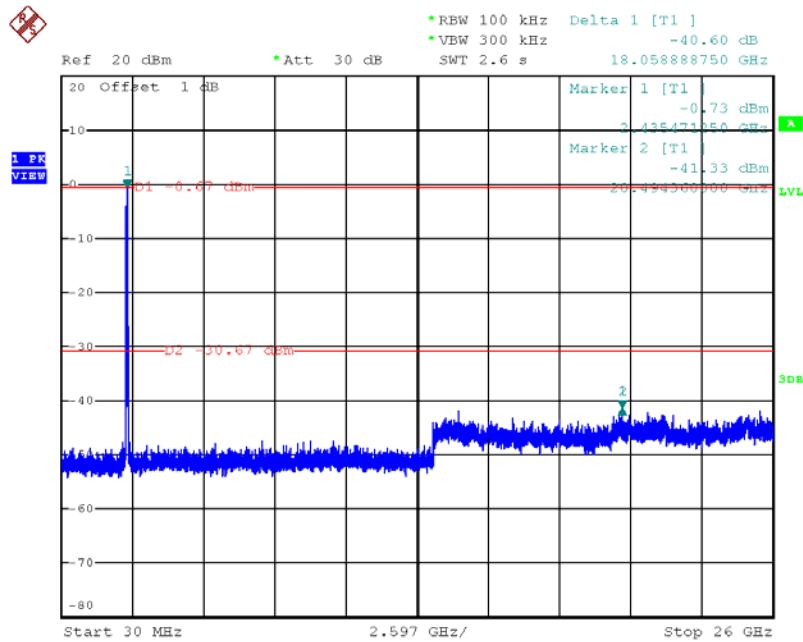

Date: 4.FEB.2013 18:16:59

Plot on Configuration IEEE 802.11n MCS0 40MHz / CH 6 (down 30dBc)

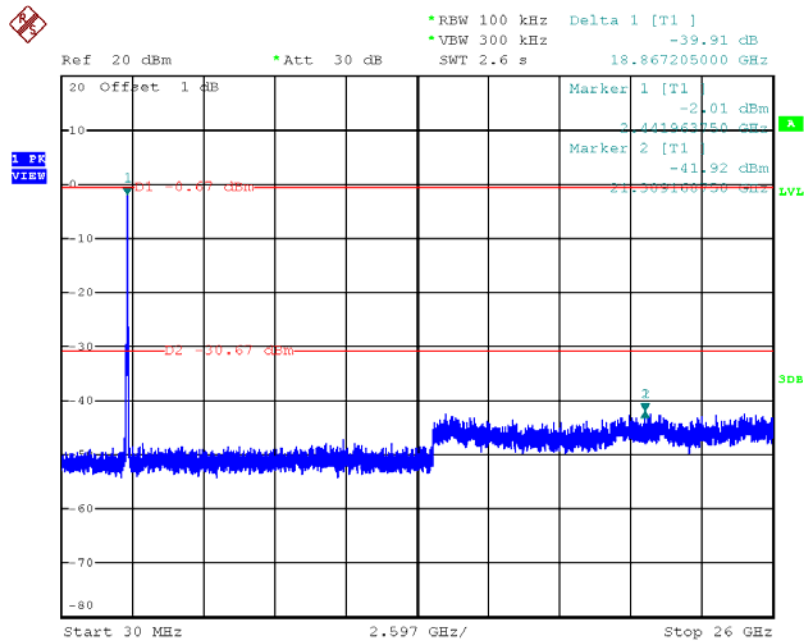

Date: 4.FEB.2013 18:18:13

Plot on Configuration IEEE 802.11n MCS0 40MHz / CH 9 (down 30dBc)

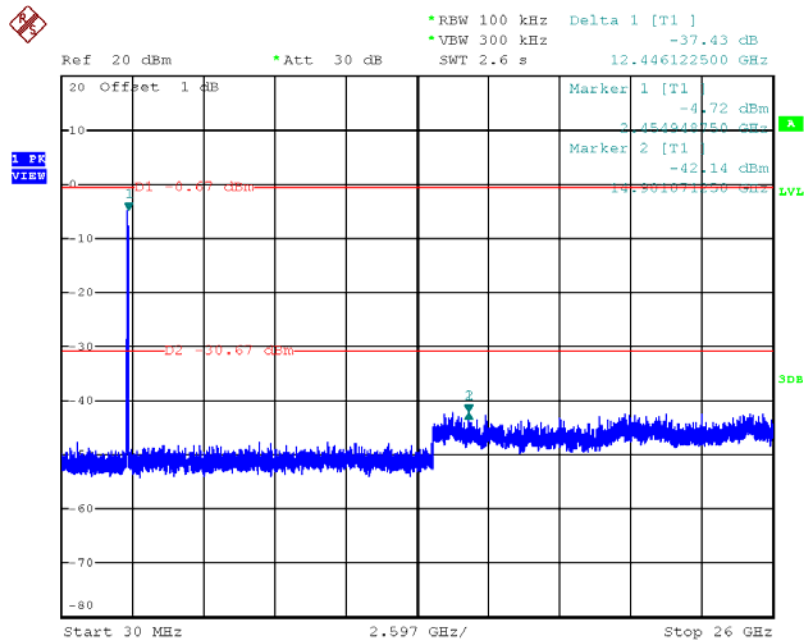

Date: 4.FEB.2013 18:19:01

Plot on Configuration IEEE 802.11n MCS0 20MHz / Reference Level

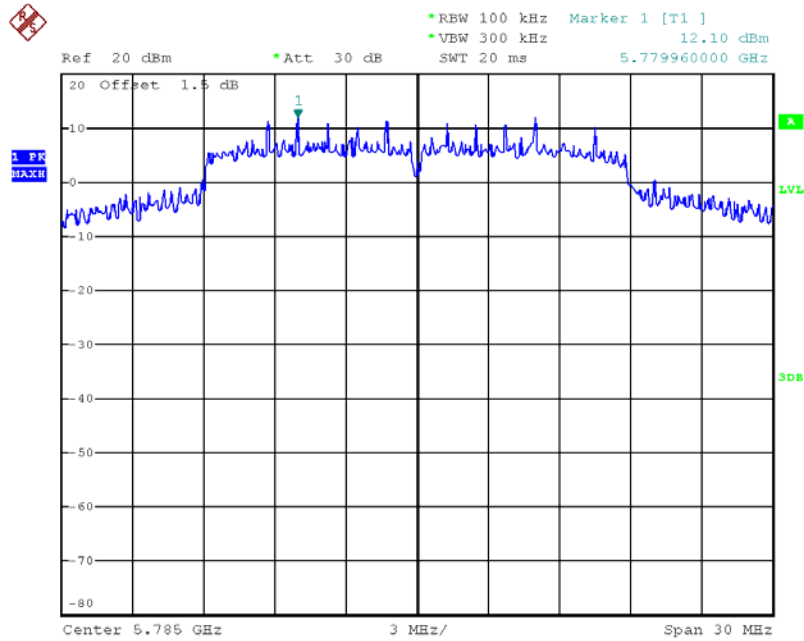

Date: 7.FEB.2013 10:40:15

Plot on Configuration IEEE 802.11n MCS0 20MHz / CH 149 (down 30dBc)

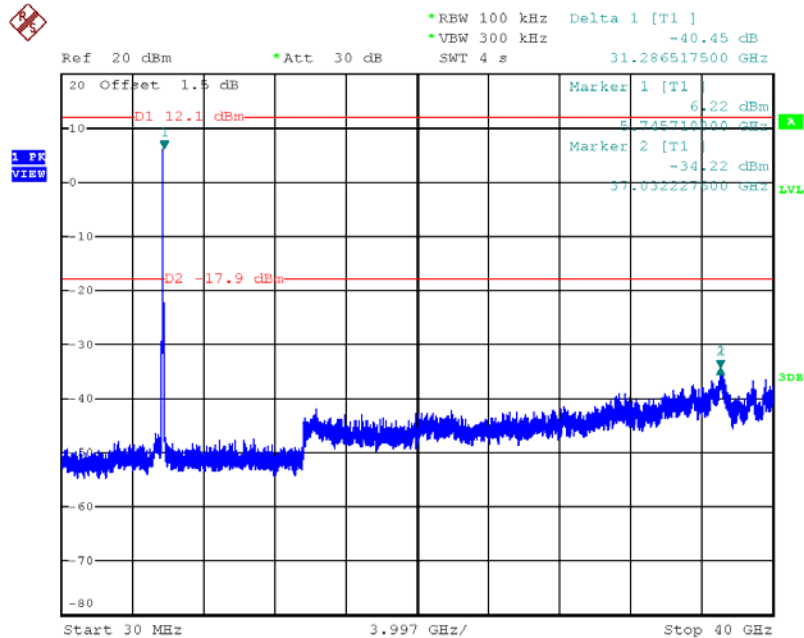

Date: 7.FEB.2013 10:49:36

Plot on Configuration IEEE 802.11n MCS0 40MHz / Reference Level

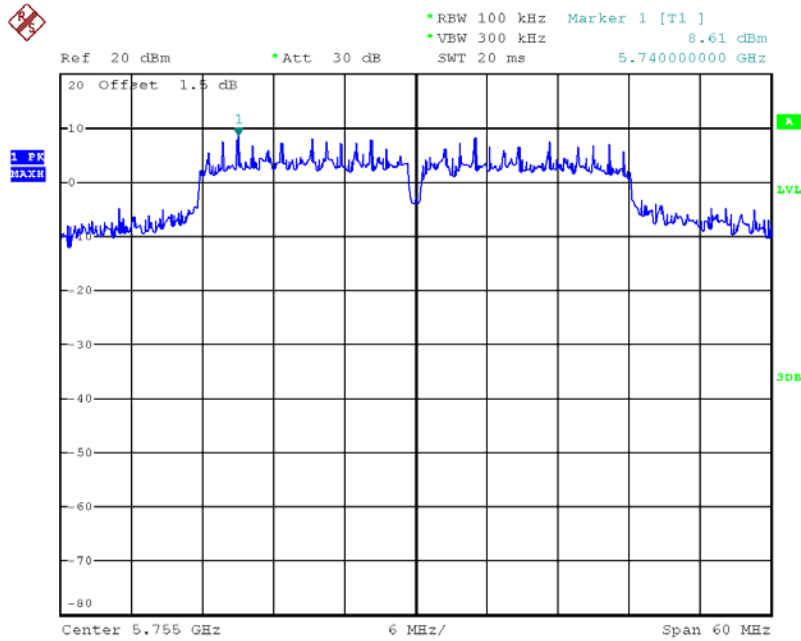

Date: 7.FEB.2013 10:42:38

Plot on Configuration IEEE 802.11n MCS0 40MHz / CH 151 (down 30dBc)

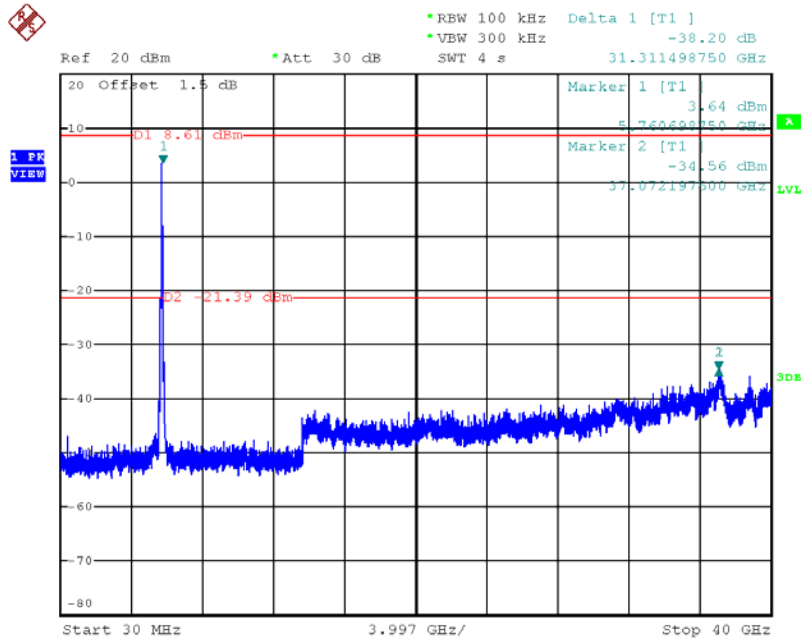

Date: 7.FEB.2013 10:52:13

Plot on Configuration IEEE 802.11b / Reference Level

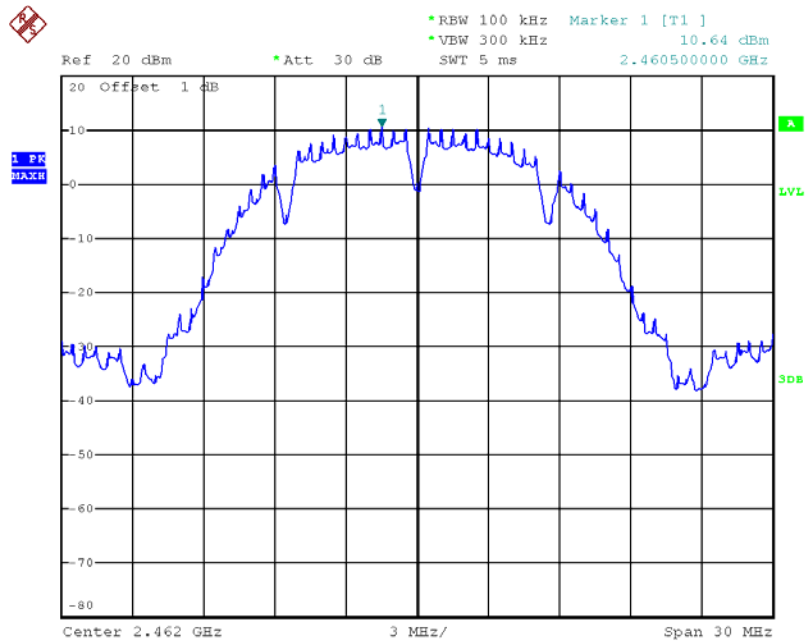

Date: 4.FEB.2013 17:51:43

Plot on Configuration IEEE 802.11b / CH 1 (down 30dBc)

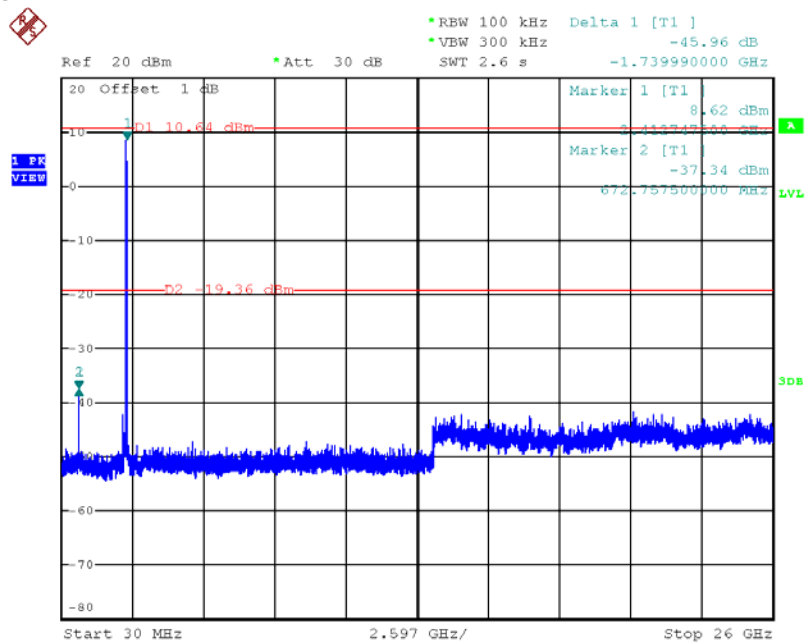

Date: 4.FEB.2013 18:29:25

Plot on Configuration IEEE 802.11b / CH 6 (down 30dBc)

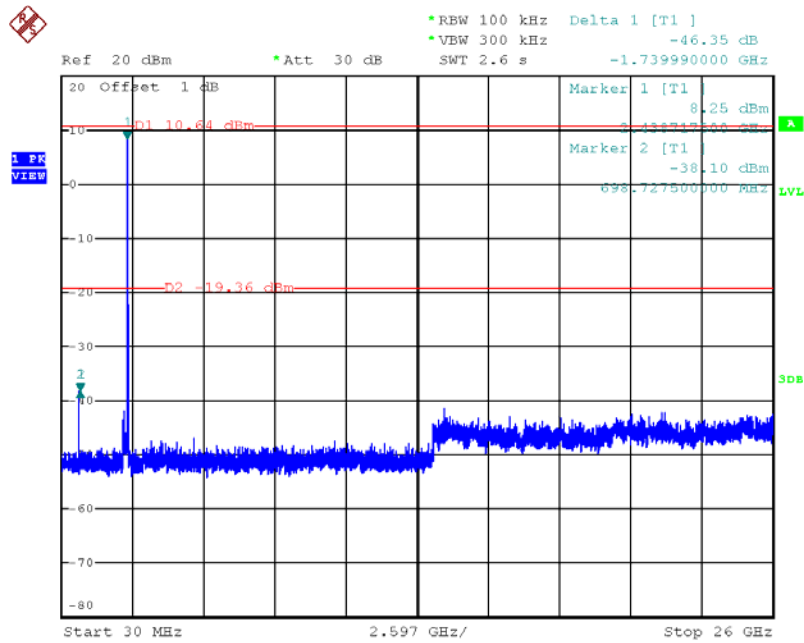

Date: 4.FEB.2013 18:28:37

Plot on Configuration IEEE 802.11b / CH 11 (down 30dBc)

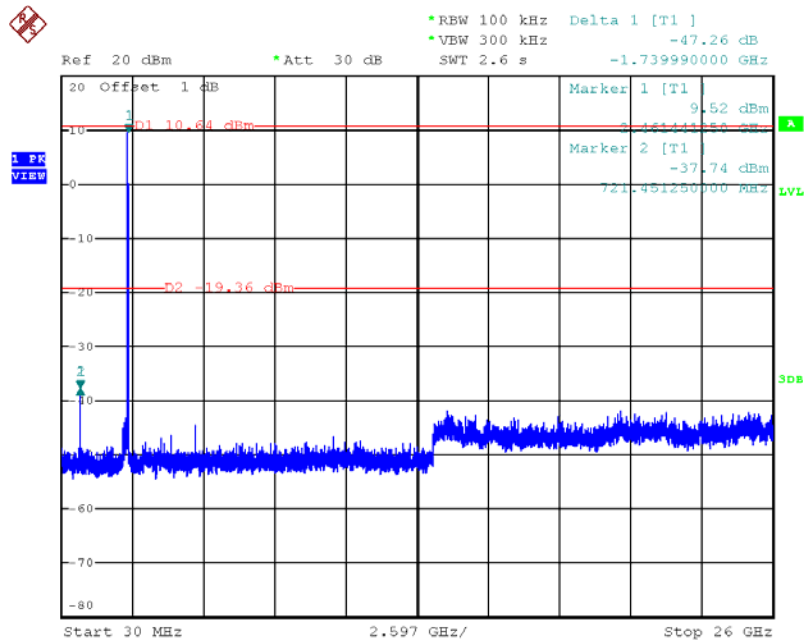

Date: 4.FEB.2013 18:26:43

Plot on Configuration IEEE 802.11g / Reference Level

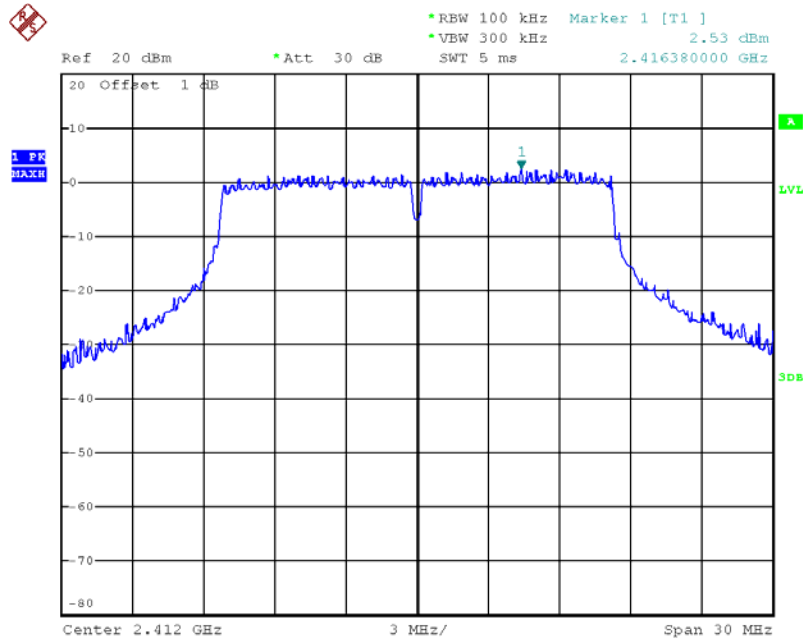

Date: 4.FEB.2013 17:56:44

Plot on Configuration IEEE 802.11g / CH 1 (down 30dBc)

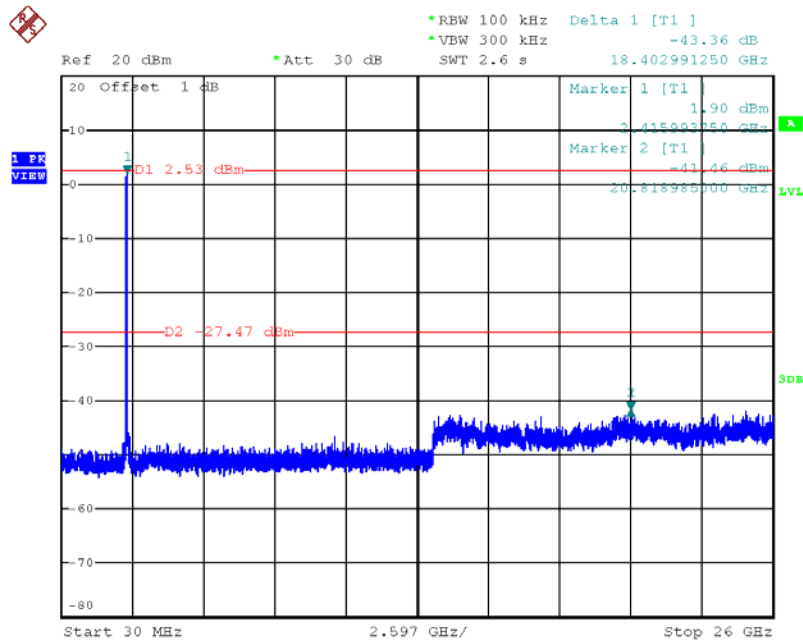

Date: 4.FEB.2013 18:23:42

Plot on Configuration IEEE 802.11g / CH 6 (down 30dBc)

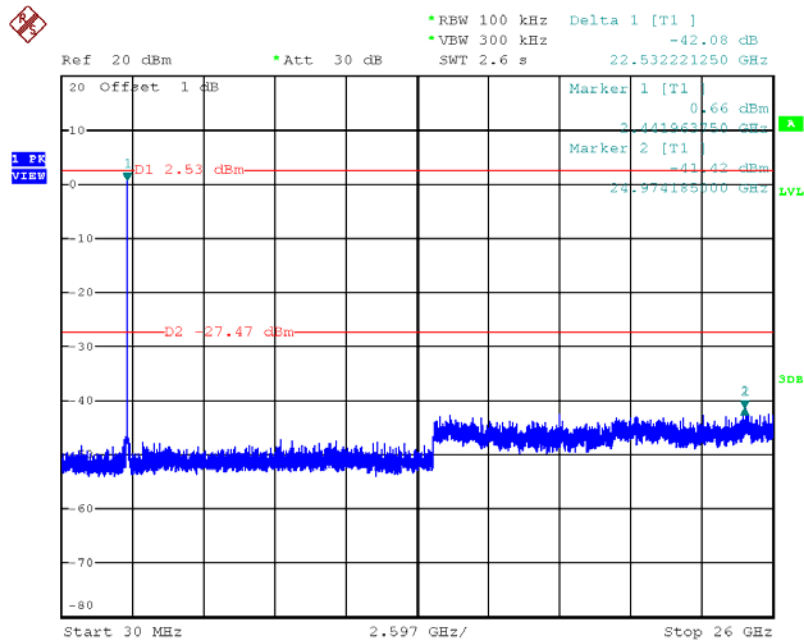

Date: 4.FEB.2013 18:24:11

Plot on Configuration IEEE 802.11g / CH 11 (down 30dBc)

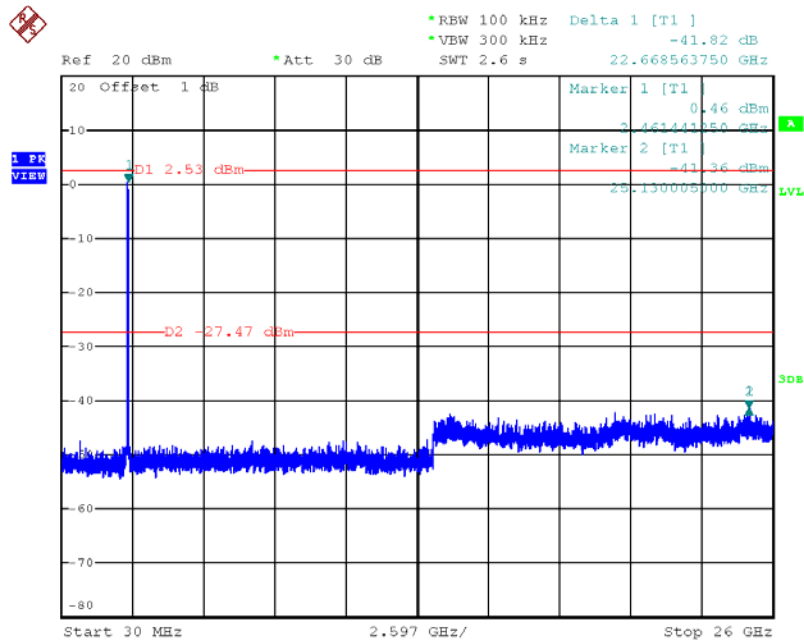

Date: 4.FEB.2013 18:24:36

Plot on Configuration IEEE 802.11a / Reference Level

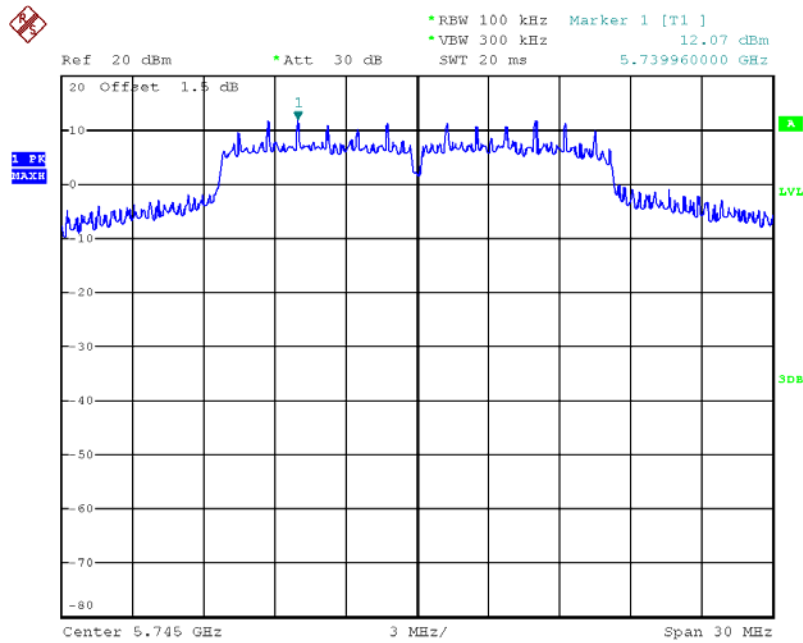

Date: 7.FEB.2013 10:35:13

Plot on Configuration IEEE 802.11a / CH 149 (down 30dBc)

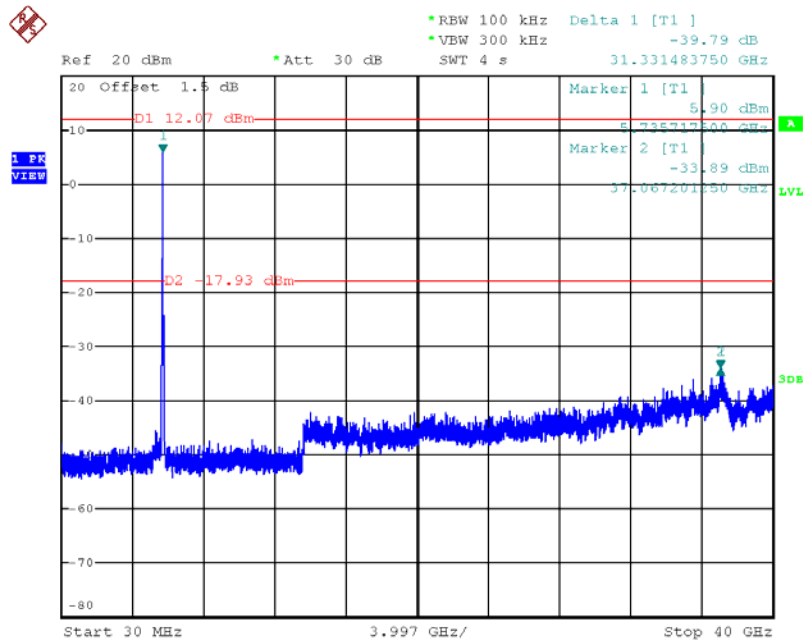

Date: 7.FEB.2013 10:47:13

Plot on Configuration IEEE 802.11a / CH 157 (down 30dBc)

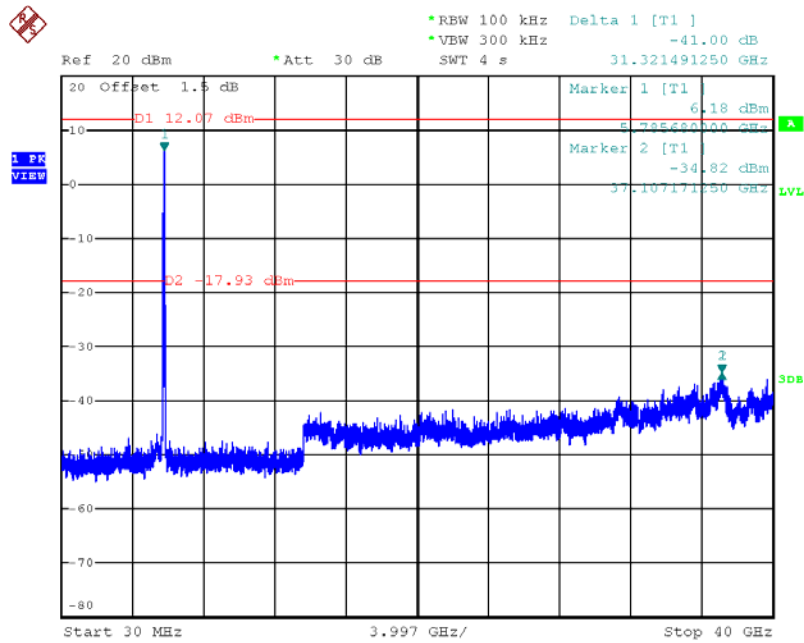

Date: 7.FEB.2013 10:47:37

Plot on Configuration IEEE 802.11a / CH 165 (down 30dBc)

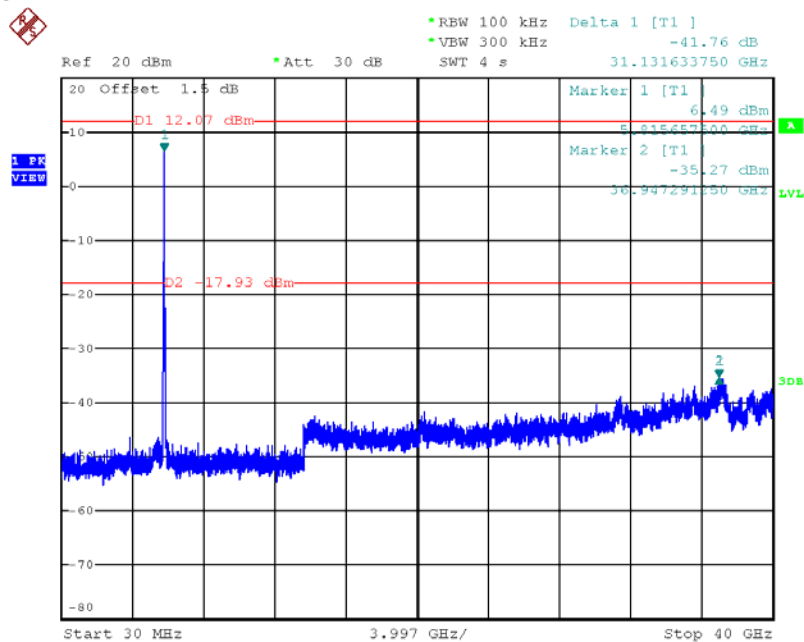

Date: 7.FEB.2013 10:47:57

4.7. Antenna Requirements

4.7.1. Limit

Except for special regulations, the Low-power Radio-frequency Devices must not be equipped with any jacket for installing an antenna with extension cable. An intentional radiator shall be designed to ensure that no antenna other than that furnished by the responsible party shall be used with the device. The use of a permanently attached antenna or of an antenna that uses a unique coupling to the intentional radiator shall be considered sufficient to comply with the provisions of this Section. The manufacturer may design the unit so that the user can replace a broken antenna, but the use of a standard antenna jack or electrical connector is prohibited. Further, this requirement does not apply to intentional radiators that must be professionally installed.

4.7.2. Antenna Connector Construction

Please refer to section 3.3 in this test report; antenna connector complied with the requirements.

5. LIST OF MEASURING EQUIPMENTS

Instrument	Manufacturer	Model No.	Serial No.	Characteristics	Calibration Date	Remark
EMI Test Receiver	R&S	ESCS 30	100377	9kHz ~ 2.75GHz	Oct. 23, 2012	Conduction (CO01-CB)
LISN	F.C.C.	FCC-LISN-50-16-2	04083	150kHz ~ 100MHz	Nov.26, 2012	Conduction (CO01-CB)
V- LISN	Schwarzbeck	NSLK 8127	8127-478	9kHz ~ 30MHz	Jun. 22, 2012	Conduction (CO01-CB)
Coupling Decoupling Network	TESEQ	ST08	24348	150kHz ~ 230MHz	Dec. 03, 2012	Conduction (CO01-CB)
COND Cable	Woken	Cable	01	0.15MHz~30MHz	Dec. 4, 2012	Conduction (CO01-CB)
Software	Audix	E3	5.410e	-	-	Conduction (CO01-CB)
BILOG ANTENNA	Schaffner	CBL6112D	22021	20MHz ~ 2GHz	Jan. 11, 2013	Radiation (03CH01-CB)
Loop Antenna	Teseq	HLA 6120	24155	9 kHz - 30 MHz	Nov. 05, 2012*	Radiation (03CH01-CB)
forHorn Antenna	EMCO	3115	00075790	750MHz~18GHz	Nov. 27, 2012	Radiation (03CH01-CB)
Horn Antenna	SCHWARZBEAK	BBHA 9170	BBHA9170252	15GHz ~ 40GHz	Nov. 23, 2012	Radiation (03CH01-CB)
Pre-Amplifier	Agilent	8447D	2944A10991	0.1MHz ~ 1.3GHz	Nov. 27, 2012	Radiation (03CH01-CB)
Pre-Amplifier	Agilent	8449B	3008A02310	1GHz ~ 26.5GHz	Nov. 23, 2012	Radiation (03CH01-CB)
Pre-Amplifier	WM	TF-130N-R1	923365	26.5GHz ~ 40GHz	Jul. 31, 2012	Radiation (03CH01-CB)
Spectrum analyzer	R&S	FSP40	100056	9KHz~40GHz	Nov. 16, 2012	Radiation (03CH01-CB)
EMI Test Receiver	R&S	ESCS 30	100355	9KHz ~ 2.75GHz	Mar. 20, 2012	Radiation (03CH01-CB)
Turn Table	INN CO	CO 2000	N/A	0 ~ 360 degree	N.C.R	Radiation (03CH01-CB)
Antenna Mast	INN CO	CO2000	N/A	1 m - 4 m	N.C.R	Radiation (03CH01-CB)
RF Cable-low	Woken	Low Cable-1	N/A	30 MHz - 1 GHz	Nov. 18, 2012	Radiation (03CH01-CB)
RF Cable-high	Woken	High Cable-1	N/A	1 GHz – 26.5 GHz	Nov. 18, 2012	Radiation (03CH01-CB)
RF Cable-high	Woken	High Cable-2	N/A	1 GHz – 26.5 GHz	Nov. 18, 2012	Radiation (03CH01-CB)
RF Cable-high	Woken	High Cable-3	N/A	1 GHz - 40 GHz	Nov. 18, 2012	Radiation (03CH01-CB)
RF Cable-high	Woken	High Cable-4	N/A	1 GHz - 40 GHz	Nov. 18, 2012	Radiation (03CH01-CB)
Signal analyzer	R&S	FSV40	100979	9KHz~40GHz	Oct. 08, 2012	Conducted (TH01-CB)

Instrument	Manufacturer	Model No.	Serial No.	Characteristics	Calibration Date	Remark
Temp. and Humidity Chamber	Ten Billion	TTH-D3SP	TBN-931011	-30~100 degree	Jun. 05, 2012	Conducted (TH01-CB)
RF Power Divider	Woken	2 Way	0120A02056002D	2GHz ~ 18GHz	Nov. 18, 2012	Conducted (TH01-CB)
RF Power Divider	Woken	3 Way	MDC2366	2GHz ~ 18GHz	Nov. 18, 2012	Conducted (TH01-CB)
RF Power Divider	Woken	4 Way	0120A04056002D	2GHz ~ 18GHz	Nov. 18, 2012	Conducted (TH01-CB)
RF Cable-high	Woken	High Cable-7	-	1 GHz – 26.5 GHz	Nov. 19, 2012	Conducted (TH01-CB)
RF Cable-high	Woken	High Cable-8	-	1 GHz – 26.5 GHz	Nov. 19, 2012	Conducted (TH01-CB)
RF Cable-high	Woken	High Cable-9	-	1 GHz – 26.5 GHz	Nov. 19, 2012	Conducted (TH01-CB)
RF Cable-high	Woken	High Cable-10	-	1 GHz – 26.5 GHz	Nov. 19, 2012	Conducted (TH01-CB)
RF Cable-high	Woken	High Cable-11	-	1 GHz – 26.5 GHz	Nov. 19, 2012	Conducted (TH01-CB)
Power Sensor	Anritsu	MA2411B	0917223	300MHz~40GHz	Nov. 28, 2012	Conducted (TH01-CB)
Power Meter	Anritsu	ML2495A	1035008	300MHz~40GHz	Nov. 27, 2012	Conducted (TH01-CB)

Note: Calibration Interval of instruments listed above is one year.

“**” Calibration Interval of instruments listed above is two years.

N.C.R. means Non-Calibration required.

6. TEST LOCATION

SHIJR	ADD : 6Fl., No. 106, Sec. 1, Shintai 5th Rd., Shijr City, Taipei, Taiwan 221, R.O.C. TEL : 886-2-2696-2468 FAX : 886-2-2696-2255
HWA YA	ADD : No. 52, Hwa Ya 1st Rd., Kwei-Shan Hsiang, Tao Yuan Hsien, Taiwan, R.O.C. TEL : 886-3-327-3456 FAX : 886-3-318-0055
LINKOU	ADD : No. 30-2, Dingfu Tsuen, Linkou Shiang, Taipei, Taiwan 244, R.O.C TEL : 886-2-2601-1640 FAX : 886-2-2601-1695
DUNGHU	ADD : No. 3, Lane 238, Kangle St., Neihu Chiu, Taipei, Taiwan 114, R.O.C. TEL : 886-2-2631-4739 FAX : 886-2-2631-9740
JUNGHE	ADD : 7Fl., No. 758, Jungjeng Rd., Junghe City, Taipei, Taiwan 235, R.O.C. TEL : 886-2-8227-2020 FAX : 886-2-8227-2626
NEIHU	ADD : 4Fl., No. 339, Hsin Hu 2 nd Rd., Taipei 114, Taiwan, R.O.C. TEL : 886-2-2794-8886 FAX : 886-2-2794-9777
JHUBEI	ADD : No.8, Lane 724, Bo-ai St., Jhubei City, HsinChu County 302, Taiwan, R.O.C. TEL : 886-3-656-9065 FAX : 886-3-656-9085