

# M8-Smart

## Installation Manual

Copyright© Teldat Dm654-I Version 1.1 05/2019 Teldat S.A.

## **Legal Notice**

### Warranty

This publication is subject to change.

Teldat S.A. offers no warranty whatsoever for information contained in this manual.

Teldat S.A. is not liable for any direct, indirect, collateral, consequential or any other damage connected to the delivery, supply or use of this manual.

# Table of Contents

I	Related Documents . . . . .	1
Chapter 1	About This Guide . . . . .	2
1.1	Supported Devices . . . . .	2
1.2	Who should read this manual? . . . . .	2
1.3	When should this manual be read? . . . . .	2
1.4	What is in this manual? . . . . .	2
1.5	What is not in this manual? . . . . .	2
1.6	How is the information organized? . . . . .	2
1.7	Technical Support . . . . .	3
Chapter 2	M8-Smart . . . . .	4
2.1	Characteristics . . . . .	4
2.1.1	Power Supply . . . . .	4
2.1.2	Hardware Monitoring . . . . .	4
Chapter 3	Components and Power Supply . . . . .	5
3.1	Components . . . . .	5
3.1.1	Front Panel . . . . .	5
3.1.2	Rear Panel . . . . .	7
3.1.3	Side Panels . . . . .	10
3.1.4	Underside Panel . . . . .	11
3.2	Mounting an Anti-Theft Security Cable. . . . .	11
3.3	Rack installation . . . . .	11
3.3.1	Standalone . . . . .	12
3.3.2	Wall mounting . . . . .	12
3.4	Plug-in Modules . . . . .	12
3.5	Power Source . . . . .	12
3.5.1	Power Source . . . . .	13
3.6	RST Button . . . . .	13
3.6.1	Rebooting the device . . . . .	13
3.6.2	Default Configuration . . . . .	14
3.7	Data connections . . . . .	14
3.7.1	4-port Ethernet switch Connections . . . . .	14
3.7.2	WAN Connections . . . . .	14
3.7.3	WWAN Antenna Connection (Cell connector). . . . .	15

3.7.4	Connecting the GPS antenna . . . . .	17
3.7.5	Wireless LAN internal antennas . . . . .	17
3.7.6	Connecting for Configuration . . . . .	17
3.8	Installing the SIM card. . . . .	18
<b>Chapter 4</b>	<b>Compliance . . . . .</b>	<b>21</b>
4.1	Manufacturer Information . . . . .	21
4.2	Risk identification . . . . .	21
4.3	Safety Warnings . . . . .	21
4.4	WEEE Information . . . . .	23
4.5	REACH . . . . .	23
4.6	Power Usage and Energy Efficiency . . . . .	23
4.7	EC Declaration of Conformity (No Radio version) . . . . .	24
4.8	EC Declaration of Conformity (Radio version) . . . . .	25
4.9	CE Marking . . . . .	25
4.10	National Restrictions . . . . .	25
4.11	FCC Statements . . . . .	25
4.11.1	Interference . . . . .	26
4.11.2	Radiation Exposure . . . . .	26
4.11.3	Radio Frequency Interference Requirements . . . . .	26
4.12	Operating Frequency . . . . .	26
4.13	Intended use of the equipment . . . . .	26
<b>Appendix A</b>	<b>Technical Information. . . . .</b>	<b>27</b>
A.1	Troubleshooting . . . . .	27
A.2	Updating the software . . . . .	28
A.3	Connecting to the device . . . . .	28
A.3.1	Connecting using the local console (Aux connector) . . . . .	28
A.4	Connectors . . . . .	29
A.4.1	LAN Connector (Switch) . . . . .	29
A.4.2	WAN Base-T Connector . . . . .	29
A.4.3	WAN SFP Connector . . . . .	29
A.4.4	WWAN Connector . . . . .	29
A.4.5	GPS Connector . . . . .	30
A.4.6	Configuration Connector . . . . .	30
A.4.7	Power Supply Connector . . . . .	30
A.5	Technical Specifications . . . . .	30
A.5.1	Hardware Architecture . . . . .	30

A.5.2	LAN Interface . . . . .	31
A.5.3	WAN Base-T Interface . . . . .	31
A.5.4	WAN SFP Interface . . . . .	31
A.5.5	Wireless WAN interface . . . . .	33
A.5.6	GPS interface . . . . .	33
A.5.7	Wireless LAN Interface (Radio 1) . . . . .	34
A.5.8	Wireless LAN Interface (Radio 2) . . . . .	35
A.5.9	Configuration Interface . . . . .	35
A.5.10	Power Supply . . . . .	35
A.5.11	Dimensions and weight . . . . .	36
A.5.12	Environmental Specifications . . . . .	36
Appendix B	CE Radio Information. . . . .	37
B.1	RF WAN specifications . . . . .	37
B.2	WIFI specifications . . . . .	38
Appendix C	FCC Radio Information . . . . .	39
C.1	LTE EM7455 WWAN Frequency Requirements . . . . .	39

## I Related Documents

Teldat Dm704-I Configuration and Monitoring

Teldat Dm748-I Software Updating

Teldat Dm781-I Cellular Interface

Teldat Dm812-I GPS

Teldat Dm830-I MNGPLAT Feature

bintec Next Generation WLAN Manual

# Chapter 1 About This Guide

This installation guide for the **M8-Smart** router contains information on how to correctly install the device in a working environment.

## 1.1 Supported Devices

The information provided in this installation guide only applies to the **M8-Smart** router.



### Note

The WiFi version includes an embedded bintec WE2022ac access point.

For more information on the latter, please refer to manual "*bintec Next Generation WLAN*".

## 1.2 Who should read this manual?

This manual should be read by the support personnel who need to configure, maintain and monitor the device.

## 1.3 When should this manual be read?

Read this guide as soon as you are ready to familiarize yourself with the device and its components.

This manual will help you understand your new device in greater depth.

## 1.4 What is in this manual?

This installation guide contains the following information:

- A description of the features available in the **M8-Smart** router.
- Technical specifications.
- Power supply requirements.
- Elements that can be connected when the router is operating.
- How to install and uninstall the modules and power sources.
- A description of the device LEDs and connectors.
- Troubleshooting.

## 1.5 What is not in this manual?

This manual does not contain information relative to the device software or its configuration. For information on how to configure this device, please see the relevant protocol manuals found in the Teldat website: <http://www.teldat.com>



### Note

For information on how to configure the bintec WE2022ac WiFi access point, refer to manual "*bintec Next Generation WLAN*".

## 1.6 How is the information organized?

Each chapter focuses on a specific part of the hardware and its components. All descriptive and technical specifications, as well as information on a given component, can be found in the relevant chapter.

## 1.7 Technical Support

Teldat S.A. offers a technical support service. Device software can be upgraded on a regular basis for maintenance purposes and in case new features are developed.

Contact information:

Web: <http://www.teldat.com> - Email: [support@teldat.com](mailto:support@teldat.com)

Tel.: +34 918 076 565 - Fax: +34 918 076 566



## Chapter 2 M8-Smart

### 2.1 Characteristics

#### 2.1.1 Power Supply

For further information on the different **M8-Smart** power supplies, please see [Components and Power Supply](#) on page 5, [Power Source](#) on page 12.

#### 2.1.2 Hardware Monitoring

The LEDs on the front panel are used to monitor the hardware in the **M8-Smart** router. These LEDs provide visual information on the state of the device and reference the condition of the hardware components, indicating whether there is connectivity, data flow, etc.

For further information on the LEDs panel, please see [Components](#) on page 5.

## Chapter 3 Components and Power Supply

The following chapter provides detailed information on the chassis of the **M8-Smart** router and its components. This information includes:

- Components.
- Information on assembly.
- Power supply.
- RST button.
- Data connection.
- SIM cards installation.
- Embedded Access Point.

### 3.1 Components

#### 3.1.1 Front Panel

The following figure shows the front panel.



Fig. 1: Front Panel of the M8-Smart device



Fig. 2: Front Panel of the M8-Smart-WiFi device



The front panel elements are as follows:







#### FRONT PANEL ELEMENTS





Item	Description
A	LEDs panel.

The LEDs panel provides information on the status of the components (if they are active or not) and on network activity.

#### LEDs

LED	Definition	Status Indication
Power 	Power / Switch On-Off	Off -> No power through PSU. On -> Powered through PSU.
Status 	General Status / Default Configuration Process	Off -> System off. Red -> Error, component operating incorrectly. Green -> System initialized and operating.

		Amber (blink) -> Default configuration.
WAN-1 	Base-T / SFP	Off -> No link or not used. Green -> Link (1G). Blinking: traffic activity. Amber -> Link (<1G). Blinking: traffic activity. Red -> Error. Interface failure.
WAN-2 	Base-T / SFP	Off -> No link or not Used. Green -> Link (1G). Blinking: traffic activity. Amber -> Link (<1G). Blinking: traffic activity. Red -> Error. Interface failure.
LAN Switch 	LAN switch interface activity	Green -> connected (all connected ports at 1G). Blinking: connection data activity. Amber -> connected (at least one port at <1G). Blinking: connection data activity. Red -> Disconnected. Off -> Interface off.
WLAN-1  (Depending on the model)	Access Point 2.4 GHz radio	Off -> Radio module and/or SSIDs inactive. Red -> No connection or disabled (shutdown). Amber -> Enabled but no associated STAs. Green -> Connected. Blinking: connection data activity.
WLAN-2  (Depending on the model)	Access Point 5 GHz radio	Off -> Radio module and/or SSIDs inactive. Red -> No connection or disabled (shutdown). Amber -> Enabled but no associated STAs. Green -> Connected. Blinking: connection data activity.
Cell (Depending on the model)	Status 	Off -> System stopped. Red -> Interface is unavailable because it is installing, disabled (shutdown) or due to auto-test failure. Amber -> Idle: <ul style="list-style-type: none"> <li>• Rapid blinking. It has not registered in the network or the quality is insufficient.</li> <li>• Slow blinking. GSM connection (GPRS).</li> <li>• Steady. WCDMA (UMTS / HSDPA) connection.</li> </ul> Green -> Connected. Blinking: connection data activity.
	RSSI. Coverage indication 	Off -> No coverage. 1-to-4 LEDs -> Level of coverage.

	SIM-1 	Off -> SIM-1 not used. ON -> SIM-1 in use.
	SIM-2 	Off -> SIM-2 not used. ON -> SIM-2 in use.
GPS (Depending on the model) 	GPS Status	Off -> GPS not available or not configured. Green -> GPS coordinates have been acquired. Blinking: NMEA data. Amber -> Bad quality (HDOP). Red -> Error.
Cloud 	Cloud Information	Off -> No Cloud configuration. Green -> Registering /connecting to the Cloud. Amber -> Connected to the Cloud. Blinking: traffic exchange with the Cloud controller. Red -> Cloud registration error.

### 3.1.2 Rear Panel

The following figure shows the rear panel. Here you will find the majority of the **M8-Smart** router connectors.

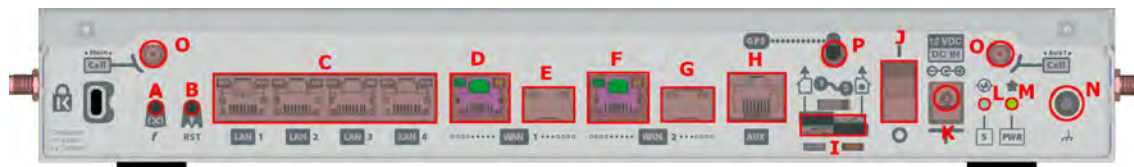

Fig. 16: Rear panel

The following table provides information on each connector, as well as a description:

#### Rear panel elements

Item	Description
A	Function.
B	RST. Reset button. For further information on how the reset button works, please see <a href="#">RST Button</a> on page 13.
C	4-port Gigabit Ethernet switch. For more information about the LAN interface, refer to: - <a href="#">4-port Ethernet switch Connections</a> on page 14 - <a href="#">LAN Connector (Switch)</a> on page 29 - <a href="#">LAN Interface</a> on page 31
D	Eth WAN-1 Base-T. WAN Gigabit Ethernet. For more information about the WAN interface, refer to:

	<ul style="list-style-type: none"> <li>- <a href="#">WAN Connections</a> on page 14</li> <li>- <a href="#">WAN Base-T Connector</a> on page 29</li> <li>- <a href="#">WAN Base-T Interface</a> on page 31</li> </ul>
E	<p>Eth WAN-1 SFP.</p> <p>For more information about the SFP interface, refer to:</p> <ul style="list-style-type: none"> <li>- <a href="#">WAN Connections</a> on page 14</li> <li>- <a href="#">WAN SFP Connector</a> on page 29</li> <li>- <a href="#">WAN SFP Interface</a> on page 31</li> </ul>
F	<p>Eth WAN-2 Base-T. WAN Gigabit Ethernet.</p> <p>For more information about the WAN interface, refer to:</p> <ul style="list-style-type: none"> <li>- <a href="#">WAN Connections</a> on page 14</li> <li>- <a href="#">WAN Base-T Connector</a> on page 29</li> <li>- <a href="#">WAN Base-T Interface</a> on page 31</li> </ul>
G	<p>Eth WAN-2 SFP.</p> <p>For more information about the SFP interface, refer to:</p> <ul style="list-style-type: none"> <li>- <a href="#">WAN Connections</a> on page 14</li> <li>- <a href="#">WAN SFP Connector</a> on page 29</li> <li>- <a href="#">WAN SFP Interface</a> on page 31</li> </ul>
H	<p>Aux. Provides access to the <b>M8-Smart</b> local console for configuration and monitoring purposes.</p> <p>For more information about the Aux connector, refer to:</p> <ul style="list-style-type: none"> <li>- <a href="#">Connecting for Configuration</a> on page 17</li> <li>- <a href="#">Configuration Connector</a> on page 30</li> <li>- <a href="#">Configuration Interface</a> on page 35</li> </ul>
I	<p>SIM Card 1-2. Slot where you can insert the SIM cards for the G modules.</p> <p>Refer to <a href="#">Installing the SIM card</a> on page 18 for more information about SIM installation.</p>
J	<p>On/Off switch.</p>
K	<p>Power source connection (PSU).</p> <p>Refer to <a href="#">Power Source</a> on page 12 for more information about Power connection and <a href="#">Power Supply</a> on page 35 for power specifications applicable to the <b>M8-Smart</b> device.</p>
L	<p>LED S (Status). Refer to <a href="#">LEDs</a> on page 5 for more information.</p>
M	<p>LED PWR (Power). Refer to <a href="#">LEDs</a> on page 5 for more information.</p>
N	<p>Functional earthing. Usually disconnected.</p>

O	<p>Cell connectors. Depending on the model.</p> <p>For more information about Cellular interface, refer to:</p> <ul style="list-style-type: none"> <li>- <a href="#">WWAN Antenna Connection (Cell connector)</a> on page 15</li> <li>- <a href="#">WWAN Connector</a> on page 29</li> <li>- <a href="#">Wireless WAN interface</a> on page 33</li> </ul>
P	<p>GPS connector. Depending on the model.</p> <p>For more information about the GPS interface, refer to:</p> <ul style="list-style-type: none"> <li>- <a href="#">Connecting the GPS antenna</a> on page 17</li> <li>- <a href="#">GPS Connector</a> on page 30</li> <li>- <a href="#">GPS interface</a> on page 33</li> </ul>

In addition to the foregoing, the rear panel also has LEDs linked to the Switch Ethernet interfaces.

### 3.1.2.1 LEDs

The following figure shows the router's Ethernet switch LED indicators:



**Fig. 17: Switch LEDs**  
**Switch LED indicators**

LED	Description
Yellow	<p>Connected to 10 M:</p> <ul style="list-style-type: none"> <li>- Steady: Not transferring data.</li> <li>- Blinking: Transferring data.</li> </ul>
Yellow + Green	<p>Connected to 100 M:</p> <ul style="list-style-type: none"> <li>- Steady: Not transferring data.</li> <li>- Blinking: Transferring data.</li> </ul>
Green	<p>Connected to 1000 M:</p> <ul style="list-style-type: none"> <li>- Steady: Not transferring data.</li> <li>- Blinking: Transferring data.</li> </ul>
None	<p>The interface is either unavailable, not installed or not registered.</p>

The following figure shows the router's WAN LED indicators, only for the Base-T connector:



Fig. 18: WAN LEDs  
WAN LED indicators

LED	Description
Yellow	Connected to 10 M: - Steady: Not transferring data. - Blinking: Transferring data.
Yellow + Green	Connected to 100 M: - Steady: Not transferring data. - Blinking: Transferring data.
Green	Connected to 1000 M: - Steady: Not transferring data. - Blinking: Transferring data.
None	Interface is either unavailable, not installed or not registered.

### 3.1.3 Side Panels

Two antenna connectors are located on the side panels.

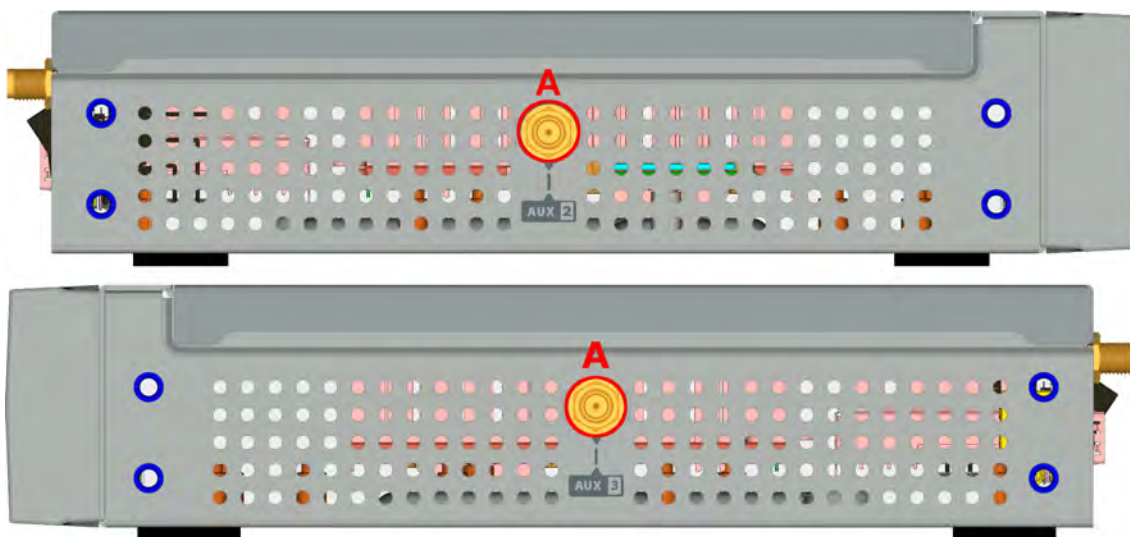

Fig. 19: Left and right side panels

The connectors are as follows:

#### Side panel connectors

Item	Description
A	Aux 2 and Aux 3 connectors. Reserved for future use.

### 3.1.4 Underside Panel

The following elements are located on the underside panel:



Fig. 20: Underside panel

#### UNDERSIDE PANEL ELEMENTS

Item	Description
A	Adhesive rubber feet (these are not required for rack mounting).

### 3.2 Mounting an Anti-Theft Security Cable

The **M8-Smart** devices have been equipped with a standard Kensington security slot to which a security cable can be attached. The T-bar lock of the security cable allows the device to be attached to an anchor point, thus preventing potential thefts.

The security slot is located on the rear panel of the housing, as shown in the following figure:

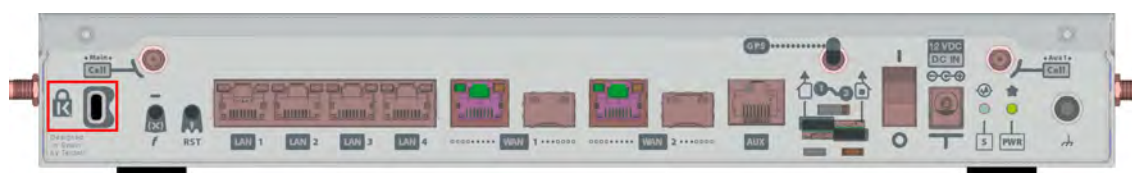

Fig. 21: Security Slot

### 3.3 Rack installation

The **M8-Smart** device can be installed in a 19" rack. The necessary strips and screws are not provided by default and must be acquired separately.

Both strips are attached to the device by means of 5 screws, as shown in the following figure:





Fig. 22: **Rack anchor bolts**

### 3.3.1 Standalone

**M8-Smart** devices can be placed as standalones on a flat, stable surface. The adhesive rubber feet must be stuck to the underside panel to prevent the router from sliding.

Make sure there is enough space around the router (for ventilation purposes) and check that the power cord and data cables can easily reach it.

### 3.3.2 Wall mounting

The **M8-Smart** cannot be mounted on a wall.

## 3.4 Plug-in Modules

The **M8-Smart** does not have plug-in modules.

## 3.5 Power Source

The **M8-Smart** router is powered through an external AC/DC power adapter.



#### Warning

The equipment must be used with the power supply provided by the manufacturer.

#### Workplace conditions. Main characteristics

- Avoid humid and/or dusty locations.
- Direct exposure to sunlight and other heat sources should be avoided. The device should not be placed amongst papers, magazines or other elements that could hinder natural air circulation.
- The device should not be placed close to strong electromagnetic fields (such as speakers, engines, etc.).
- Knocks and/or strong vibrations should be avoided during transport, operation and storage.



#### Warning

The electric current in power cables, telephone lines and communication cables is dangerous. To prevent electric shocks, before installing, handling or opening the equipment covers, connect and disconnect the cables following the steps set forth in [Connecting](#) on page 13 and [Disconnecting](#) on page 13.

### 3.5.1 Power Source

To connect the power supply to the device, please follow the steps set out in [Connecting](#) on page 13.

To avoid electric shocks, residual current circulation and other unwanted effects that affect communications, the following is recommended:



#### Warning

For safety and EMC purposes, the external power supply must be connected to a grounded power outlet.



#### Note

We recommended plugging all interconnected communication devices to the same grounded power outlet.

#### 3.5.1.1 Connecting

- Ensure that the on/off power supply switch is in the OFF position (0).
- Make sure the power supply is NOT connected to the mains or to the device.
- Connect all data cables.
- Connect the external adapter power cable to the device.
- Connect the adapter power cable to the main supply (wall socket).
- Set the device's on/off power supply switch in the ON position (1).

#### 3.5.1.2 Disconnecting

- Set the on/off power supply switch in the OFF position (0).
- Disconnect the adapter power cable to the main supply (wall socket).
- Remove the power supply cable from the device.
- Disconnect the data cables.

## 3.6 RST Button

The different RST button features are described below.



Fig. 23: RST button

### 3.6.1 Rebooting the device

Once the device is operating normally, pressing the RST button will force a restart.



#### Note

It will also force a restart of the embedded Access Point (if present).

### 3.6.2 Default Configuration

The RST button allows you to boot the device with its default configuration (including the embedded Access Point, if present) through the following steps:

- With the device switched off, press and hold the RST button down while you turn on the router using the ON/OFF switch (1).
- The PWR LED (green) will light up and LED 'S' will begin to blink (amber). It will carry on blinking for 10 seconds.
- To boot the device with the default configuration, release the RST button while LED 'S' is still blinking (i.e. before the 10-second period expires).

The router's default configuration establishes the following access IP and mask address:

- IP address: 192.168.1.1
- IP mask: 255.255.255.0

If available, the embedded access point's default configuration establishes the following parameters:

- IP address: DHCP client with no. 192.168.0.252/24 as default
- Credentials: admin / admin
- Only GUI access enabled



#### Note

Some devices leave the factory with customized settings. This personalization means your router's default configuration (and that of the embedded access point, where applicable) may be different from the one shown above.

## 3.7 Data connections

The **M8-Smart** router has the following data connections.

### 3.7.1 4-port Ethernet switch Connections

The **M8-Smart** router incorporates a 4-port 10/100/1000 Base-T switch with automatic MDI/MDIX to connect to a local area network (LAN).

Please pay careful attention to the labeling to avoid mistaking this switch for other types of ports:



Fig. 24: LAN switch ports



#### Note

Only the LAN 1 connector is available during booting and in BIOS mode.

### 3.7.2 WAN Connections

The **M8-Smart** has 4 Ethernet interfaces for WAN connection. These ports have 2 connectors - SFP for an optical link and RJ45 for a 10/100/1000 Base-T link - but they cannot work simultaneously. These interfaces are totally independent from the switch and are handled as every other interface.

Please pay careful attention to the labeling to avoid mistaking these ports for other types of ports:

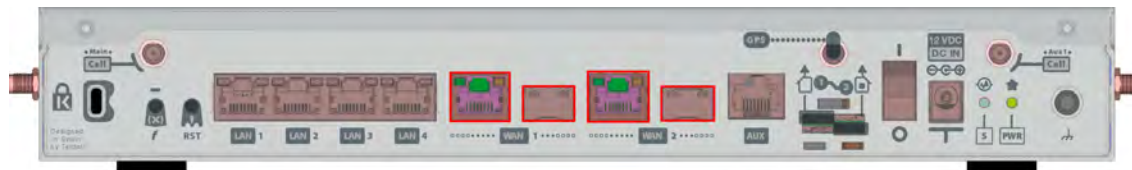

Fig. 25: WAN connectors



#### Note

WAN connectors do not work during booting and in BIOS mode.

### 3.7.2.1 Laser information



Chose SFP transceivers that meet the following regulations

- Class 1
- IEC/EN60825-1:2007 2nd Edition or later, European standard
- FCC 21 CFR Chapter 1, Subchapter J (in accordance with FDA and CDRH requirements)
- Application of CE marking in accordance with the 2014/30/EU EMC Directive and the 2014/35/EU Low Voltage Directive
- UL and/or CSA registered component for North America
- 47 CFR Part 15, Class A



#### Warning

Laser Radiation. Do not use optical instruments directly or without proper protection. CLASS 1 LASER PRODUCT

The SFP modules to be installed in the card socket should be class 1 devices that comply with the IEC/EN 60825-1:2007 standard

### 3.7.3 WWAN Antenna Connection (Cell connector)

The **M8-Smart** has two connectors for WWAN antennas in the rear panel and two connectors for WWAN antennas in the side panels (on models equipped with this interface).

To assemble or dismantle the antennas, simply screw or unscrew them into or out of the connectors labeled *Cell* (located on the rear panel and side panels of the router).

Installing these antennas in the **M8-Smart** is essential to improve the quality of the signal received and transmitted by the cellular model.



#### Note

To achieve high-quality performance, the router should always have the WWAN antennas installed.

For the *cellular* interface to work, the router needs the corresponding software license.

Some cellular telephony technologies use the antenna diversity technique to improve the quality of the signal received. The **M8-Smart** router family incorporates several WWAN connectors for this.



Fig. 27: WWAN Main and Aux 1 antennas

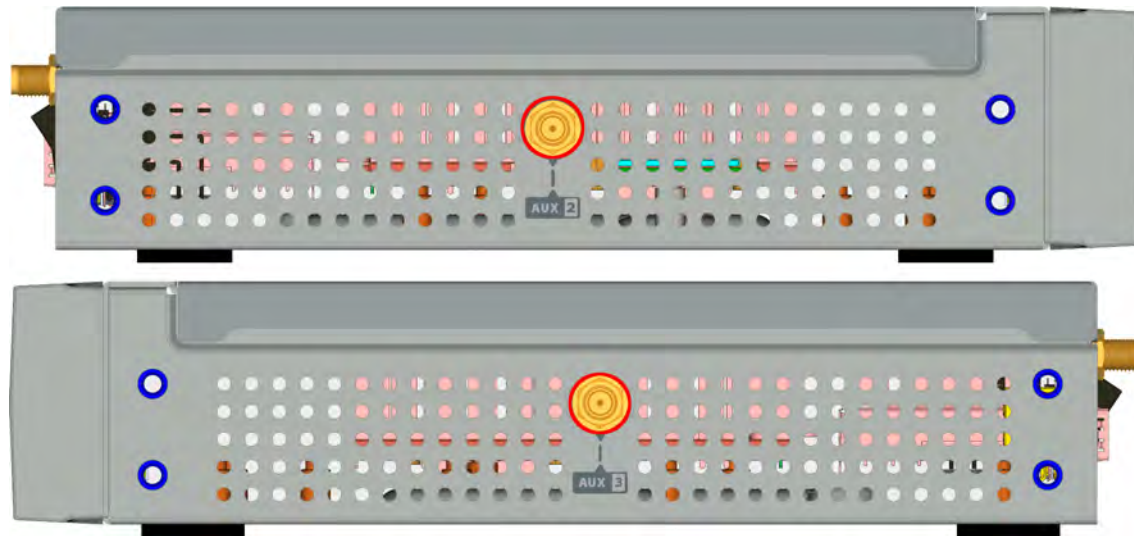

Fig. 28: WWAN Aux 2 and Aux 3 antennas (future use)

When the Main and Aux 1 antennas are not directly connected to the router but installed through extension cords, the minimum distance between the two must be 7 cm. The maximum recommended distance between them is 25 cm.

To achieve optimum performance, the radio frequency accessories installed (antennas and cables) should be those recommended by Teldat.

Teldat offers a range of suitable accessories (90° mount antennas, antennas for outdoor installation, antennas for ceiling installation, extension cables, etc.) for different locations.

### 3.7.3.1 Placing the Antenna

The orientation of the antenna and its location with respect to other wireless devices and radiation sources (such as communication devices, personal computers, etc.) can influence device performance.

Antennas transmit and receive radio signals. Environmental factors (such as the distance between the device and the base station), physical obstacles and other RF interferences can impact their performance.

For optimum coverage, follow these steps:

- Whenever possible, place the antenna where there are no physical obstacles. Obstacles between the antenna and the base station degrade the wireless signal. Place the antenna above ground level facing the nearest base station.
- Density of materials also affects antennas. Place them away from any type of wall, metal screens, mirrors, etc.
- Do not place the antenna near columns, which may throw shadows and reduce the coverage area.
- Keep the antenna away from metal pipes (such as canals, air-conditioning, etc.).
- Please bear in mind that other wireless devices such as telephones, microwaves, etc., can temporarily interfere with the quality of the radio signal.
- We do not recommend installing antennas near, or between, racks containing communication devices, computers, etc. Use an extension cable and place the device outside.

The following recommendations are applicable to all wireless devices:

- Do not touch or move the antenna while the device is transmitting or receiving.
- When the antenna is transmitting, do not touch any equipment that contains devices that radiate very close to, or touching, any exposed part of the body (particularly face and eyes).

- Do not install the device in areas where the atmosphere is potentially explosive.
- Wireless devices can cause interferences in other devices. Do not use the device in areas where medical equipment is installed.

### 3.7.4 Connecting the GPS antenna

The **M8-Smart** has an SMA connector to connect a passive GPS antenna (on models equipped with this interface).

The cable used to connect the antennas must be valid for radio frequency (RF) signal communications of up to 1.5 GHz and impedances of 50 Ohms. Please note that the quality and length of an antenna cable can affect the RF signal quality (both transmitted and received). This, in turn, will affect the device's coverage and data exchange rates.

The following image shows the position of the GPS antenna connector.

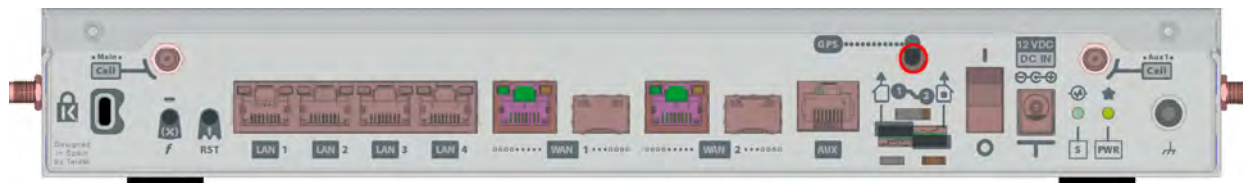

Fig. 29: GPS antenna connector



#### Note

The GPS will not work properly unless you install a valid SIM card.



#### Note

The device is shipped without a GPS antenna. Please, contact your dealer for a list of recommended GPS antennas.

For further information on GPS configuration, please see the following manual: Teldat Dm812-I GPS.

### 3.7.5 Wireless LAN internal antennas

The **M8-Smart** has two integrated antennas for a Wireless LAN module covering both the 2.4 GHz and 5 GHz bands.

The WLAN module is internal and is only available for the **M8-Smart-WiFi** version.



Fig. 30: M8-Smart-WiFi version

### 3.7.6 Connecting for Configuration

The **M8-Smart** has a RJ45 female connector on the front panel (labeled "Aux.") that provides access to the device's local console

For further information, please see [Connecting to the device](#) on page 28.





Fig. 31: Aux. Connector

### 3.8 Installing the SIM card

The **M8-Smart** is equipped with two Wireless WAN interfaces that may need a SIM card (or two) to operate. Certain services (CDMA) provided by some carriers in several countries do not require SIM cards.

The **M8-Smart** is equipped with two SIM trays located on the rear panel of the router, as shown in the following figure.



Fig. 32: SIM trays

To insert the SIM cards in the SIM trays, first remove the cover following these steps:

- (1) Insert a screwdriver in the slot.

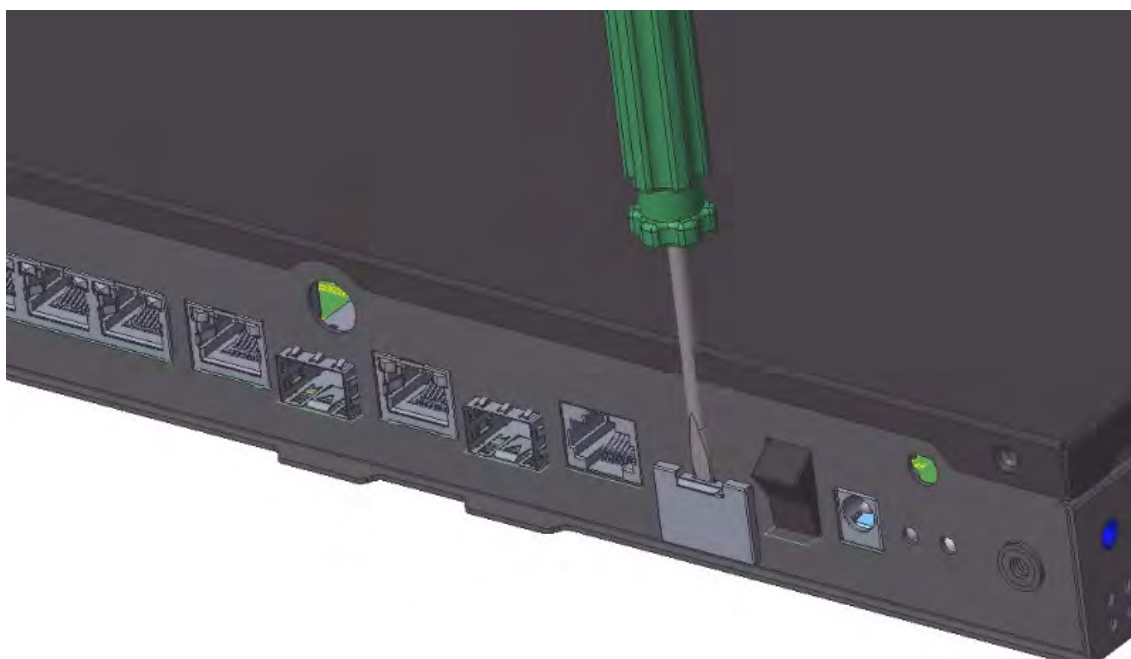
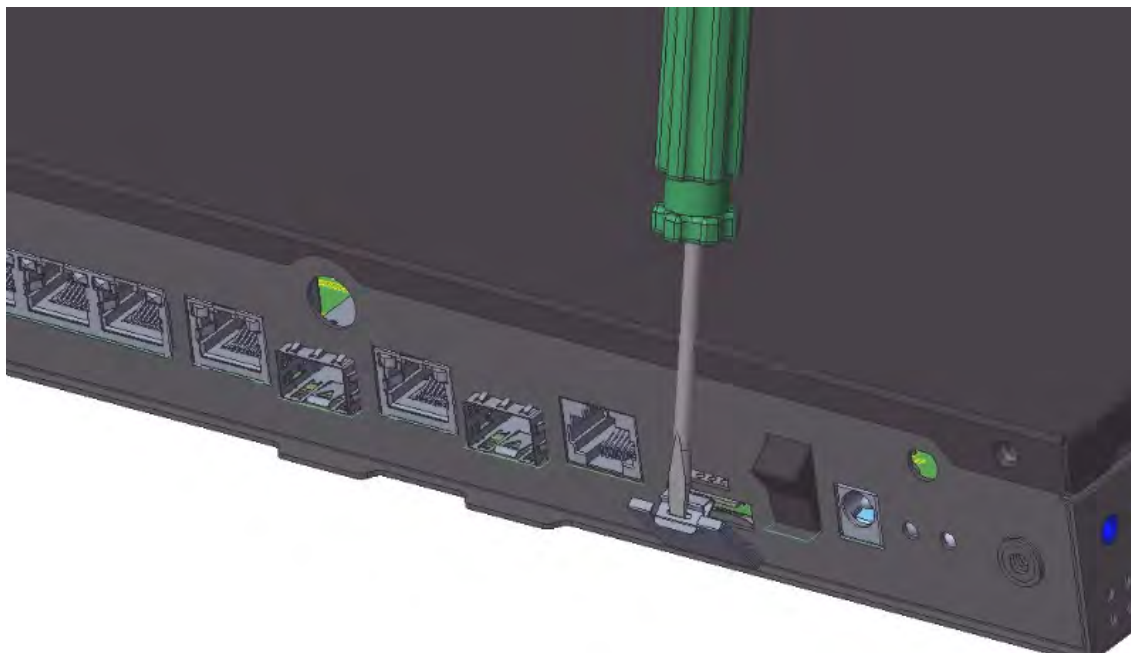

Fig. 33: Insert the screwdriver in the slot

- (2) Press to open the cover.



*Fig. 34: Press to open the SIM trays cover*

- (3) Insert the SIM card into the selected tray



*Fig. 35: Press to insert the SIM card into the tray*

- (4) Press to remove the SIM card from the tray





Fig. 36: Press to remove the SIM card from the tray



#### Warning

Never install the SIM cards when the device is switched on.

Always disconnect the device from the main power supply before installing the SIM cards.

Always disconnect the device before removing the casing to access the trays.

When inserting the SIM cards, please protect yourself against electrostatic discharges (ESD).

Do not touch the SIM card connectors.

## Chapter 4 Compliance

### 4.1 Manufacturer Information

<i>Brand</i>	Teldat
<i>Manufacturer</i>	Teldat S.A.
<i>Country</i>	Spain
<i>Postal Address</i>	Isaac Newton, 10 Parque Tecnológico de Madrid, 28760 Tres Cantos, Madrid, Spain
<i>International Phone</i>	+34 91 807 65 65

### 4.2 Risk identification



WARNING: Signal word used to designate a potentially dangerous situation that may cause severe injuries or death if not avoided.

### 4.3 Safety Warnings



The equipment must be used with the power supply provided by the manufacturer.

Das Gerät muss mit dem vom Hersteller gelieferten Netzteil betrieben werden.

El equipo debe ser usado con la fuente de alimentación proporcionada por el fabricante.



The electric current in power cables, telephone lines and communication cables is dangerous. To prevent electric shocks, before installing, handling or opening the equipment covers, connect and disconnect the cables following the steps set forth in [Connecting](#) on page 13 and [Disconnecting](#) on page 13.



Der elektrische Strom in Strom-, Telefon- und Datenkabeln ist gefährlich. Um Elektroschocks zu vermeiden, trennen Sie vor der Installation, der Bedienung oder dem Öffnen des Geräts die Kabel wie in den Abschnitten Verbinden und Trennen beschrieben.

La tensión eléctrica de los cables de alimentación, de los cables de la línea telefónica y de los cables de comunicación es peligrosa. Para evitar descargas, antes de instalar, mover o abrir las cubiertas de este equipo, conecte y desconecte los cables siguiendo el orden que se detalla en "Conectar" y "Desconectar".



For safety and EMC purposes, the external power supply must be connected to a grounded power outlet.

Aus Sicherheits- und EMV-Gründen muss das externe Netzteil an eine geerdete Steckdose

	angeschlossen werden.
	Para cumplir con las recomendaciones de seguridad y EMC, la fuente de alimentación se debe conectar a una toma con tierra.
	<p>Laser Radiation. Do not use optical instruments directly or without proper protection. CLASS 1 LASER PRODUCT</p> <p>The SFP modules to be installed in the card socket should be class 1 devices that comply with the IEC/EN 60825-1:2007 standard.</p>
	<p>Laserstrahlung. Nicht direkt mit optischen Instrumenten hineinsehen. LASERPRODUKT DER KLASSE 1</p> <p>SFP-Module, die im Kartenschacht installiert werden sollen, sollten Klasse-1-Geräte in Übereinstimmung mit IEC/EN 60825-1:2007 sein.</p>
	<p>Radiación laser. No mirar directamente con instrumentos ópticos. Producto LASER CLASE 1.</p> <p>Los módulos SFP que se instalen en el socket de la tarjeta deben ser dispositivos de CLASE 1 de acuerdo con la norma IEC/EN 60825-1:2007.</p>
	<p>Never install the SIM cards when the device is switched on.</p> <p>Always disconnect the device from the main power supply before installing the SIM cards.</p> <p>Always disconnect the device before removing the casing to access the trays.</p> <p>When inserting the SIM cards, please protect yourself against electrostatic discharges (ESD).</p> <p>Do not touch the SIM card connectors.</p>
	<p>Installieren Sie keine SIM-Karten, solange das Gerät eingeschaltet ist.</p> <p>Trennen Sie das Gerät immer von der Stromversorgung, bevor Sie eine SIM-Karte installieren.</p> <p>Trennen Sie das Gerät immer von der Stromversorgung, bevor Sie das Gehäuse für einen Zugang zu den SIM-Halterungen öffnen.</p> <p>Schützen Sie sich gegen elektrostatische Entladung (ESD), wenn Sie eine SIM-Karte installieren.</p> <p>Berühren Sie die SIM-Karten-Kontakte nicht.</p>
	<p>No instale nunca las tarjetas SIM con el equipo encendido.</p> <p>Desconecte siempre el equipo de la red antes de instalar las tarjetas SIM.</p> <p>Desconecte siempre el equipo antes de desmontar la carcasa para acceder a las bandejas.</p> <p>Al insertar las tarjetas SIM, protéjase contra descargas electroestáticas (ESD).</p> <p>No toque los conectores de las tarjetas SIM.</p>

## 4.4 WEEE Information



The waste container symbol with the >X< indicates that the device must be disposed of separately from normal domestic waste at the end of its useful service life. Please use an appropriate waste disposal facility.

Das auf dem Gerät befindliche Symbol mit dem durchgekreuzten Müllcontainer bedeutet, dass das Gerät am Ende der Nutzungsdauer bei den hierfür vorgesehenen Entsorgungsstellen getrennt vom normalen Hausmüll zu entsorgen ist.

El símbolo del contenedor con la cruz, que se encuentra en el aparato, significa que cuando el equipo haya llegado al final de su vida útil, deberá ser llevado a los centros de recogida previstos, y que su tratamiento debe estar separado del de los residuos urbanos.

## 4.5 REACH

In compliance with the REACH Candidate List, the delivered product and product packaging do not contain chemical substances above a concentration limit of 0.1% weight by weight (w/w). This declaration will be updated whenever any changes occur or other chemical substances are added to the REACH Candidate List. Information is currently provided to consumers upon request.

## 4.6 Power Usage and Energy Efficiency

This device is an Energy Related Product (ErP) with High Network Availability (HiNA), and automatically switches to a power-saving Network Standby mode when no packets have been transmitted for 10 minutes (default set).

It can also be turned off through a power switch to save energy when it is not needed.

Network Standby:

- No Radio version: 6.1 W
- Radio Version: 6.5W

All the interfaces can be shutdown individually:

- Interfaces controlled by M8 Smart (all but WiFi): refer to CIT configuration manuals to learn how to disable each interface.
- WiFi interfaces: refer to the "*bintec Next Generation WLAN Manual*" to learn how to disable each of the radio interfaces.

## 4.7 EC Declaration of Conformity (No Radio version)

English (EN)	<p>Hereby, Teldat S.A. declares that telecommunications equipment <b>M8-Smart</b> complies with:</p> <p>Directive 2014/30/EU (EMC)</p> <p>Directive 2014/35/EU (LVD)</p> <p>Directive 2009/125/EC (ErP)</p> <p>Directives 2011/65/EU and 2015/863/EU (RoHS)</p> <p>of the European Parliament and of the Council.</p>
German (DE) Deutsch	<p>Hiermit erklärt Teldat S.A. die Übereinstimmung des Geräts <b>M8-Smart</b> mit:</p> <p>Richtlinie 2014/30/EU (EMC)</p> <p>Richtlinie 2014/35/EU (LVD)</p> <p>Richtlinie 2009/125/EG (ErP)</p> <p>Richtlinien 2011/65/EU und 2015/863/EU (RoHS)</p> <p>des Europäischen Parlaments.</p>
Spanish (ES) Español	<p>Por la presente, Teldat S.A. declara que el tipo de equipo de telecomunicaciones <b>M8-Smart</b> es conforme con:</p> <p>Directiva 2014/30/UE (EMC)</p> <p>Directiva 2014/35/UE (LVD)</p> <p>Directiva 2009/125/CE (ErP)</p> <p>Directivas 2011/65/UE y 2015/863/UE (RoHS)</p> <p>del Parlamento Europeo y del Consejo.</p>

The EC declaration of conformity and additional product documentation can be accessed here:

<http://www.teldat.com/conformity>

## 4.8 EC Declaration of Conformity (Radio version)

English (EN)	<p>Hereby, Teldat S.A. declares that radio equipment <b>M8-Smart</b> complies with:</p> <p>Directive 2014/53/EU (RED)</p> <p>Directive 2009/125/EC (ErP)</p> <p>Directives 2011/65/EU and 2015/863/EU (RoHS)</p> <p>of the European Parliament and of the Council.</p>
German (DE) Deutsch	<p>Hiermit erklärt Teldat S.A. die Übereinstimmung des Geräts <b>M8-Smart</b> mit:</p> <p>Richtlinie 2014/53/EU (RED)</p> <p>Richtlinie 2009/125/EG (ErP)</p> <p>Richtlinien 2011/65/EU und 2015/863/EU (RoHS)</p> <p>des Europäischen Parlaments.</p>
Spanish (ES) Español	<p>Por la presente, Teldat S.A. declara que el tipo de equipo radioeléctrico <b>M8-Smart</b> es conforme con:</p> <p>Directiva 2014/53/UE (RED)</p> <p>Directiva 2009/125/CE (ErP)</p> <p>Directivas 2011/65/UE y 2015/863/UE (RoHS)</p> <p>del Parlamento Europeo y del Consejo.</p>

The EC declaration of conformity and additional product documentation can be accessed here:

<http://www.teldat.com/conformity>

## 4.9 CE Marking

This equipment is in conformity with the CE procedures and marking.



## 4.10 National Restrictions

In accordance with Article 10 of 2014/53/EU, we inform you that national restrictions and requirements may apply when it comes to authorization. These can evolve with time. Teldat S.A. recommends that you check with local authorities what the latest status of national regulations is.

This product is supplied with antennas in order to fulfill local regulations. Do not choose other antennas. To comply with power limits and RF exposure requirements, the antennas used for this transmitter must be installed so that people keep a separation distance of, at least, 20 cm.

## 4.11 FCC Statements

### 4.11.1 Interference

This equipment has been tested and found to comply with the limits for a Class B digital device, pursuant to Part 15 of the FCC Rules. These limits are designed to provide reasonable protection against harmful interference in a residential installation.

This equipment generates, uses and can radiate radio frequency energy and, if not installed and used in accordance with the instructions, may cause harmful interference to radio communications. However, there is no guarantee that interference will not occur in a particular installation. If this equipment does cause harmful interference to radio or television reception, which can be determined by turning the equipment off and on, the user is encouraged to try to correct the interference by one of the following measures:

- Reorient or relocate the receiving antenna.
- Increase the separation between the equipment and receiver.
- Connect the equipment into an outlet on a circuit different from that to which the receiver is connected.
- Consult the dealer or an experienced radio/TV technician for help.

FCC Caution: Any changes or modifications not expressly approved by the party responsible for compliance could void the user's authority to operate this equipment.

This device complies with Part 15 of the FCC Rules. Operation is subject to the following two conditions: (1) this device may not cause harmful interference, and (2) this device must accept any interference received, including interference that may cause undesired operation.

This device is restricted for indoor use.

### 4.11.2 Radiation Exposure

This equipment complies with FCC radiation exposure limits set forth for an uncontrolled environment. This equipment should be installed and operated with minimum distance 20cm between the radiator & your body.

### 4.11.3 Radio Frequency Interference Requirements

This device is restricted to indoor use due to its operation in the 5.15 to 5.25 GHz frequency range.

The FCC requires this product to be used indoors to reduce the potential for harmful interference to co-channel Mobile Satellite systems.

High power radars are allocated as primary users of the 5.25 to 5.35 GHz and 5.65 to 5.85 GHz bands. These radar stations can cause interference with and/or damage this device.

## 4.12 Operating Frequency

To find out more about operating frequencies and the maximum radio-frequency power transmitted in the frequency bands in which the radio equipment operates, see appendix [RF WAN specifications](#) on page 37 and [WIFI specifications](#) on page 38.

## 4.13 Intended use of the equipment

The **M8-Smart** can be deployed as a Customer Premises Equipment (CPE) in enterprise branch offices or in environments managed by the service provider.

This product must only be used indoors.

## Appendix A Technical Information

### A.1 Troubleshooting

The following table can help you solve problems when installing the device. If you cannot resolve the issue, please contact your dealer for more information.

Symptom	Solution
None of the LEDs lights up on the router.	Check the power supply to the router (power source, ON/OFF switch, main power outlet).
You have forgotten the router's access password.	Ignore the configuration through the RST button (as explained in the relevant section).
The <i>LAN switch</i> LED never lights up in green.	Check the Ethernet cable and the connection to the network.
The <i>Eth WAN</i> LED never lights up in green.	Check the Ethernet cable and the connection to the network. Check the appropriate license is available for use.
The <i>Wi-Fi</i> LED never lights up in green.	Check the router configuration and that of the remote station(s). Check the appropriate license is available for use.
The <i>Cell</i> LED never lights up.	If the device has a cellular interface, check the SIM installation, PIN setting and network configuration: APN and Authentication parameters. For further information, please see manual: "Teldat <i>Dm781-I Cellular Interface</i> ".
None <i>RSSI</i> LED lights up.	Check the antenna connection. Make sure the SMA connector is correctly threaded and tightened. Check the signal strength. Make sure that the device location has enough coverage. If you use external antennas, change their position and check if RSSI is improved. Check if there is service availability in your area. For further information, please see manual: "Teldat <i>Dm781-I Cellular Interface</i> ".
None <i>SIM</i> LED lights up.	Check that the SIM card is correctly inserted in the corresponding tray. If the SIM is protected by a PIN, verify it has been properly configured. For further information, please see manual: "Teldat <i>Dm781-I Cellular Interface</i> ".
The <i>GPS</i> LED never lights up in green.	Check the antenna connection. Make sure the SMA connector is correctly threaded and tightened. Check the antenna location, change their position and check if HDOP is improved. Check if the SIM is properly installed. For further information, please see manual: "Teldat <i>Dm812-I GPS</i> ".
The <i>Cloud</i> LED never lights up in green.	Check if the server configuration has a valid management endpoint configured (feature management platform).



For further information, please see manual: "Teldat *Dm830-I MNGPLAT feature*".

## A.2 Updating the software

The **M8-Smart** router can be updated to new versions. Please contact your dealer for further details on new releases.

There are several ways to update a Teldat router. For further information, please see manual: "Teldat *Dm748-I Software Updating*".

The software required to update Teldat routers is supplied in a format known as **distribution**, which contains all the files needed to update your device and in-depth information on their content.

The embedded access point (if available) can also be updated to new versions. Please contact your dealer for further details on new releases for the embedded access point.

## A.3 Connecting to the device

### A.3.1 Connecting using the local console (Aux connector)

The **M8-Smart** router has a RJ45 female connector on the front panel, known as **Aux**, which provides access to the device's local console.



Fig. 38: **Aux Connector**

To configure this, you must connect the **Aux** port to an asynchronous terminal (or to a PC with terminal emulation).



#### Note

The configuration for the terminal must be:

- Speed: 9600 bps.
- Eight data bits.
- One stop bit.
- No parity bit.
- No type of flow control.

Connection to the configuration port can be carried out using the the RJ45 connector cable, supplied with the device, and an RJ45 female-DB9 female adapter (also provided).

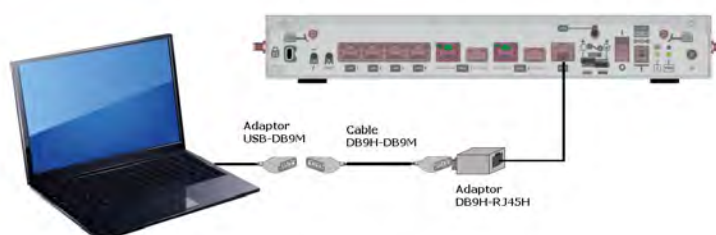
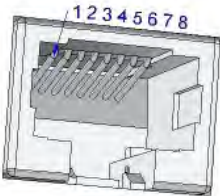

Fig. 39: **Connecting for Configuration**

For further information, please see manual: "Teldat *Dm704-I Configuration and Monitoring*".

## A.4 Connectors

### A.4.1 LAN Connector (Switch)

RJ45 LAN	RJ45 PIN	FE Signals	GE Signals
	1	BI-DA+	BI-DA+
	2	BI-DA-	BI-DA-
	3	BI-DB+	BI-DB+
	4	--	BI-DC+
	5	--	BI-DC-
	6	BI-DB-	BI-DB-
	7	--	BI-DD+
	8	--	BI-DD-

### A.4.2 WAN Base-T Connector

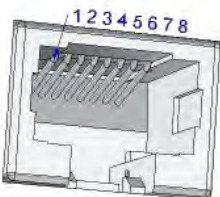
RJ45 WAN	RJ45 PIN	FE Signals	GE Signals
	1	BI-DA+	BI-DA+
	2	BI-DA-	BI-DA-
	3	BI-DB+	BI-DB+
	4	--	BI-DC+
	5	--	BI-DC-
	6	BI-DB-	BI-DB-
	7	--	BI-DD+
	8	--	BI-DD-

### A.4.3 WAN SFP Connector

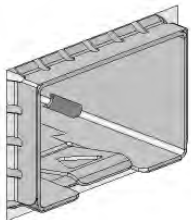
SFP	
	Standard SFP connector

### A.4.4 WWAN Connector

Devices equipped with this interface have up to four SMA female connectors installed.

SMA Female	PIN	ANT
	Internal	RF in/out
	External	GND

### A.4.5 GPS Connector

Devices equipped with this interface have one SMA female connector installed.

SMA Female	PIN	ANT
	Internal	RF in/out
	External	GND

### A.4.6 Configuration Connector

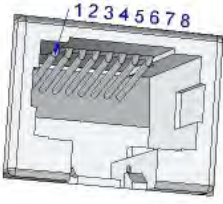
RJ45 CONFIGURATION	RJ45 PIN	CONF
	1	--
	2	RxD
	3	GND
	4	--
	5	--
	6	GND
	7	TxD
	8	--

### A.4.7 Power Supply Connector

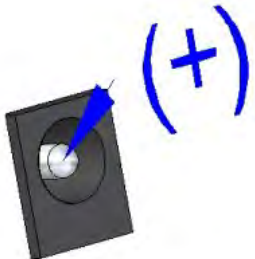
Jack 5.5/2.5mm	PIN
	Internal -> POSITIVE
	External -> NEGATIVE

## A.5 Technical Specifications

### A.5.1 Hardware Architecture

PROCESSORS	Freescale QorIQ.
MEMORY	1 Gbyte in SDRAM.
STORAGE UNIT	FLASH Memory (32 Mbytes).

### A.5.2 LAN Interface

PROTOCOLS	Ethernet (802.3).
PORTS	4 port switch managed with MDI/MDX auto-detection.
SPEED	10/100/1000 Mbps (Base-T).
CONNECTOR	RJ45 female.

### A.5.3 WAN Base-T Interface

STANDARDS	Ethernet (802.3).
SPEED	10/100/1000 Mbps (Base-T).
CONNECTOR	RJ45 female.

### A.5.4 WAN SFP Interface

STANDARDS	802.1Q (VLAN). 1000-Base-X. MSA and SFF 8472 compliant
SPEED	1000 Mbps full duplex.
TYPES	LX/LH (single-mode 1310 nm). SX (multi-mode 850 nm). ZX (single-mode 1550 nm).
CONNECTOR	Standard SFP connector.

### A.5.5 Wireless WAN interface

<p>WWAN Standard/Bands</p>	<p>EM7455:</p> <ul style="list-style-type: none"> <li>• LTE:             <ul style="list-style-type: none"> <li>• FDD: B1-B5, B7, B12, B13, B17, B20, B25, B26, B29, B30</li> <li>• TDD: B41</li> <li>• 2xCA :                 <ul style="list-style-type: none"> <li>• B1 + B8;</li> <li>• B2 + B2/B5/B12/B13/B29;</li> <li>• B3 + B7/B20;</li> <li>• B4 + B4/B5/B12/B13/B29;</li> <li>• B5 + B2/B4/B30;</li> <li>• B7 + B3/B7/B20;</li> <li>• B8 + B1;</li> <li>• B12 + B2/B4/B30;</li> <li>• B13 + B2/B4;</li> <li>• B20 + B3/B7;</li> <li>• B30 + B5/B12;</li> <li>• B41 + B41</li> </ul> </li> </ul> </li> <li>• WCDMA: B1, B2, B3, B4, B5, B8</li> </ul> <p>EM7430:</p> <ul style="list-style-type: none"> <li>• LTE:             <ul style="list-style-type: none"> <li>• FDD: B1, B3, B5, B7, B8, B18, B19, B21, B28</li> <li>• TDD: B38-B41</li> <li>• 2xCA :                 <ul style="list-style-type: none"> <li>• B1 + B8/B18/B19/B21;</li> <li>• B3 + B5/B7/B19/B28;</li> <li>• B5 + B3/B7;</li> <li>• B7 + B3/B5/B7/B28;</li> <li>• B8 + B1;</li> <li>• B18 + B1;</li> <li>• B21 + B1/B19;</li> <li>• B28 + B3/B7;</li> <li>• B38 + B38</li> <li>• B39 + B39</li> <li>• B40 + B40</li> <li>• B41 + B41</li> </ul> </li> </ul> </li> </ul>
<p>Speed (DL/UL)</p>	<p>EM7455:</p> <ul style="list-style-type: none"> <li>• LTE Cat 6.             <ul style="list-style-type: none"> <li>• FDD: 300Mbps/50Mbps</li> <li>• TDD: 222Mbps/26Mbps</li> </ul> </li> <li>• HSPA+ Cat 24/6: 42Mbps/5.76Mbps</li> </ul> <p>EM7430:</p> <ul style="list-style-type: none"> <li>• LTE Cat 6.</li> </ul>

	<ul style="list-style-type: none"> <li>• FDD: 300Mbps/50Mbps</li> <li>• TDD: 222Mbps/26Mbps</li> <li>• HSPA+ Cat 24/6: 42Mbps/5.76Mbps</li> </ul>
GNSS	GPS/GLONASS/BeiDou/Galileo/QZSS
CONNECTOR	Three SMA connectors.
SIM Slots	2 Mini-SIM (2FF) ISO/IEC 7810:2003, ID-000 (1.8V / 3V)
ANTENNA	Devices equipped with this interface are shipped with two multiband swivel-mount dipole antennas.

### A.5.6 GPS interface

STANDARDS	NMEA.
GNSS	<ul style="list-style-type: none"> <li>• GPS (L1, 1559-1610 MHz)</li> <li>• GLONASS (G1, 1559-1610 MHz)</li> <li>• BeiDou (B1, 1559-1610 MHz)</li> <li>• Galileo (E1, 1559-1610 MHz)</li> </ul>
SATELLITE CHANNELS	<ul style="list-style-type: none"> <li>• 16 GPS</li> <li>• 14 GLONASS</li> <li>• 16 BeiDou</li> <li>• 12 Galileo</li> </ul> <p>Simultaneous tracking.</p>
CONNECTOR	SMA female.
ANTENNA	Active and Passive.

### A.5.7 Wireless LAN Interface (Radio 1)

WLAN standards	802.11b; 802.11g; 802.11n (MIMO 2x2) 2.4 GHz
Frequency bands 2.4 GHz indoor/outdoor (EU)	2.4 GHz Indoor/Outdoor (2412-2484 MHz) max. 100 mW EIRP (20dBm).
WLAN modes	2.4 GHz Operation: 802.11b only; 802.11g only; 802.11b/g; 802.11b/g/n; 802.11g/n.
Modulation Techniques	OFDM: BPSK, QPSK, DBPSK, DQPSK, 16-QAM, 64-QAM, 256-QAM.
Automatic Rate Selection (ARS)	Available.
Transmission rate	Automatic.
Data rates	802.11b/g: 11, 5.5, 2 and 1 Mbps (DSSS modulation); 54, 48, 36, 24, 18, 12, 9 and 6 Mbps (OFDM modulation).  802.11n (20 MHz channel bandwidth): MCS0-15 allow up to 150 Mbps PHY rate at 20 MHz channel bandwidth, 2 streams, Short guard Intervall. Up to 173.3 Mbps (QAM-256) together with clients there support QAM-256.  802.11n (40 MHz channel bandwidth): MCS0-15 allow up to 300 Mbps PHY rate at 40 MHz channel bandwidth, 2 streams, Short guard Intervall. Up to 400 Mbps (QAM-256) together with clients there support QAM-256.
Short guard interval (802.11n)	On/off switchable; increase of throughput by reduction of the guard intervals from 800ns to 400ns
Output power limitation	Adjustable
Output Power @ 2.4 GHz	Max. 16,35 dBm
Bandwidth (802.11n)	20 MHz / (40MHz with coexistence check under preparation)
Antenna	Integrated directional dual-band MIMO array with 3.65 dB peak gain @ 2.4 GHz

### A.5.8 Wireless LAN Interface (Radio 2)

WLAN standards	IEEE 802.11ac/an; MU-MIMO 2x2; 20/40/80 MHz; 5 GHz
Frequency bands 5 GHz indoor (EU)	5 GHz indoor (5150-5350 MHz) max. 200 mW EIRP allowed
Frequency bands 5 GHz outdoor (EU)	5 GHz outdoor (5470-5725 MHz) max. 1000 mW EIRP allowed
WLAN modes	5 GHz Operation: 802.11a only; 802.11a/n; 802.11n.
Modulation Techniques	OFDM: BPSK, QPSK, DBPSK, DQPSK, 16-QAM, 64-QAM, 256-QAM.
Automatic Rate Selection (ARS)	Available.
Transmission rate	Automatic.
Data rates	802.11a,h (5 GHz): 54, 48, 36, 24, 18, 12, 9 and 6 Mbps (OFDM modulation)  802.11n, 20 MHz channel bandwidth: MCS0-15 allow up to 150 Mbps PHY rate at 20 MHz channel bandwidth, 2 streams, Short guard interval  802.11n, 40 MHz channel bandwidth: MCS0-15 allow up to 300 Mbps PHY rate at 40 MHz channel bandwidth, 2 streams, Short guard interval  802.11ac, 20 MHz channel bandwidth: Allow up to 173 Mbps PHY rate with two streams or up to 87 Mbps PHY with one stream  802.11ac, 40 MHz channel bandwidth: Allow up to 400 Mbps PHY rate with two streams or up to 200 Mbps PHY with one stream  802.11ac, 80 MHz channel bandwidth: Allow up to 867 Mbps PHY rate with two streams or up to 433 Mbps PHY with one stream
Short guard interval (802.11n)	On/off switchable; increase of throughput by reduction of the guard intervals from 800ns to 400ns
Output power limitation	Adjustable
Output power @ 5 GHz	Max. 18,12 dBm (200mW EIRP)
Bandwidth (802.11ac)	20/40/80 MHz
Antenna	Integrated directional dual-band MIMO array with 4.88 dB peak gain @ 5 GHz

### A.5.9 Configuration Interface

LOCAL TERMINAL	RS-232 9600-8-N-1 without flow control.
CONNECTOR	RJ45 female on the rear panel.

### A.5.10 Power Supply

INPUT VOLTAGE	+12V DC.
INPUT CURRENT	1.3 A (No radio model), 2.1 A (Radio model).
CONNECTOR	Jack 5.5/2.5 mm.



### A.5.11 Dimensions and weight

TYPE	Desktop / chassis for a 1 U high Rack mount enclosure.
LENGTH x WIDTH x HEIGHT	No WiFi version: 310 x 180 x 45 mm. WiFi version: 310 x 197 x 45 mm.
WEIGHT	No WiFi version: 1.68 Kg WiFi version: 2.04 Kg.

### A.5.12 Environmental Specifications

TEMPERATURE	OPERATING NORMALLY: 0 °C to 45 °C. STORED: -25 °C to 70 °C.
RELATIVE HUMIDITY	5 % to 90 %.

## Appendix B CE Radio Information

This section includes some of the European radio frequencies that comply with the CE regulatory requirements. Customers may obtain additional country-specific bands upon request.

### B.1 RF WAN specifications

LTE/WCDMA connectivity is provided by Sierra Wireless modules. The exact modules installed will depend on your particular router model.

Technology: LTE. EM7455 specifications.

Bands	Frequencies	Conducted Transmit Power
Band 1	Tx: 1920-1980 MHz Rx: 2110-2170 MHz	+23 dBm $\pm$ 1 dB
Band 3	Tx: 1710-1785 MHz Rx: 1805-1880 MHz	+23 dBm $\pm$ 1 dB
Band 7	Tx: 2500-2570 MHz Rx: 2620-2690 MHz	+22 dBm $\pm$ 1 dB
Band 20	Tx: 832-862 MHz Rx: 791-821 MHz	+23 dBm $\pm$ 1 dB

Technology: LTE. EM7430 specifications.

Bands	Frequencies	Conducted Transmit Power
Band 1	Tx: 1920-1980 MHz Rx: 2110-2170 MHz	+23 dBm $\pm$ 1 dB
Band 3	Tx: 1710-1785 MHz Rx: 1805-1880 MHz	+23 dBm $\pm$ 1 dB
Band 7	Tx: 2500-2570 MHz Rx: 2620-2690 MHz	+22 dBm $\pm$ 1 dB

Technology: UMTS(WCDMA)/ HSDPA/ HSUPA/ HSPA+/ DC-HSPA+. EM7455 specifications.

Bands	Frequencies	Conducted Transmit Power
Band 1	Tx: 1920-1980 MHz Rx: 2110-2170 MHz	+23 dBm $\pm$ 1 dB
Band 3	Tx: 170-1785 MHz Rx: 1805-1880 MHz	+23 dBm $\pm$ 1 dB
Band 8	Tx: 880-915 MHz Rx: 925-960 MHz	+23 dBm $\pm$ 1 dB

Technology: UMTS(WCDMA)/ HSDPA/ HSUPA/ HSPA+/ DC-HSPA+. EM7430 specifications.

Bands	Frequencies	Conducted Transmit Power
Band 1	Tx: 1920–1980 MHz Rx: 2110–2170 MHz	+23 dBm ± 1 dB
Band 8	Tx: 880–915 MHz Rx: 925–960 MHz	+23 dBm ± 1 dB

## B.2 WIFI specifications

This product is supplied with internal antennas.

Technology: WLAN 802.11a/b/g/n/ac.

Frequency Range	802.11b/g/n-HT20: 2412 ~ 2472MHz; 802.11n-HT40: 2422 ~ 2462MHz; 802.11a /n-HT20/ac-VHT20: 5180~5240 MHz, 5260~5320 MHz, 5500~5700 MHz; 802.11n-HT40/ac-VHT40: 5190~5230 MHz, 5270~5310 MHz, 5510~5670 MHz; 802.11ac-VHT80: 5210 MHz, 5290 MHz, 5530 MHz, 5610 MHz.
Number of Channels	802.11a/n-HT20/ac-VHT20: 19 802.11n-HT40/ac-VHT40: 9 802.11ac-VHT80: 4
Type of modulation	<b>2.4 GHz:</b> 802.11b: DSSS 802.11g/n: OFDM. <b>5.0 GHz:</b> 802.11a/n/ac: OFDM.

## Appendix C FCC Radio Information

### C.1 LTE EM7455 WWAN Frequency Requirements

This device contains FCC ID: N7NEM7455.

This device is restricted to mobile and fixed applications and must not be co-located or operating in conjunction with any other antenna or transmitter except in accordance with FCC multi-transmitter evaluation procedures as documented in this filing.

This device has 5 MHz and 10 MHz bandwidth modes for LTE Bands 13 and 30 (700/2300 MHz); 1.4 MHz, 3 MHz, 5 MHz and 10 MHz bandwidth modes for LTE Bands 5 and 12 (850/700 MHz); 1.4 MHz, 3 MHz, 5 MHz, 10 MHz and 15 MHz modes for LTE Band 26 (850 MHz); 1.4 MHz, 3 MHz, 5 MHz, 10 MHz, 15 MHz and 20 MHz bandwidth modes for LTE Bands 2, 25 and 4 (1900 and 1700 MHz); 5 MHz, 10 MHz, 15 MHz and 20 MHz bandwidth modes for LTE Bands 7 and 41 (2500/2600 MHz).

The following table shows output power conducted at the antenna terminal:

FCC Rule Part	Frequency Range	Output
22H	824.0 - 849.0 MHz	0.224 W
27	1710.0 - 1755.0 MHz	0.221 W
24E	1850.0 - 1910.0 MHz	0.231 W
27	699.0 - 716.0 MHz	0.248 W
27	699.0 - 716.0 MHz	0.215 W
27	777.0 - 787.0 MHz	0.247 W
27	777.0 - 787.0 MHz	0.227 W
90	814.0 - 824.0 MHz	0.242 W
90	814.0 - 824.0 MHz	0.212 W
90	814.0 - 824.0 MHz	0.136 W
22H	824.0 - 849.0 MHz	0.25 W
22H	824.0 - 849.0 MHz	0.188 W
22H	824.0 - 849.0 MHz	0.24 W
22H	824.0 - 849.0 MHz	0.144 W
27	1710.0 - 1755.0 MHz	0.251 W
27	1710.0 - 1755.0 MHz	0.186 W
27	1710.0 - 1755.0 MHz	0.234 W
27	1710.0 - 1755.0 MHz	0.145 W
24E	1850.0 - 1915.0 MHz	0.251 W
24E	1850.0 - 1915.0 MHz	0.248 W
24E	1850.0 - 1915.0 MHz	0.227 W
27	2305.0 - 2315.0 MHz	0.197 W
27	2305.0 - 2315.0 MHz	0.191 W

27	2305.0 - 2315.0 MHz	0.175 W
27	2496.0 - 2690.0 MHz	0.197 W
27	2496.0 - 2690.0 MHz	0.171 W
27	2496.0 - 2690.0 MHz	0.109 W
27	2500.0 - 2570.0 MHz	0.196 W
27	2500.0 - 2570.0 MHz	0.133 W
27	2500.0 - 2570.0 MHz	0.167 W
27	2500.0 - 2570.0 MHz	0.105 W