



LCIE

Accreditation  
N° 1-0312  
Scope  
available on  
www.cofrac.fr



# TEST REPORT

Number  
Composition of document

# RADIO

N° 106440-611204-E-Cr-2012-01-10  
52 pages

**FCC Part 15 of September 9, 2009**  
**RSS 243 Issue 2 (2005)**  
**FCC Part 95 Subpart I (2008)**  
**RSS-102 of November 2005**  
**RSS-210 of June 2007**

## Issued to

SORIN CRM  
Parc d'affaires NOVEOS  
4, Avenue Réaumur  
92140 CLAMART Cedex

Mme de JESO

## Apparatus under test

Trade mark  
Manufacturer  
Type  
Serial number  
FCC ID

SMARTVIEW MONITOR  
SORIN GROUP  
SELCO EOLANE COMBREE  
SMARTVIEW MONITOR KA 960 (US version with RTC)  
HB1107001S  
YSGKA960

## Test date

May 2<sup>nd</sup> to June 14<sup>th</sup>, 2011

## Tests performed by

Stéphane PHOUDIAH

## Test site

LCIE Fontenay aux Roses (92) and Moret/Loing (77)

## Initial date of issue

December 7<sup>th</sup>, 2011

## Date of correction

January 10<sup>th</sup>, 2012

## Date of issue

January 10<sup>th</sup>, 2012

Approved by :  
**Philippe SISSOKO**

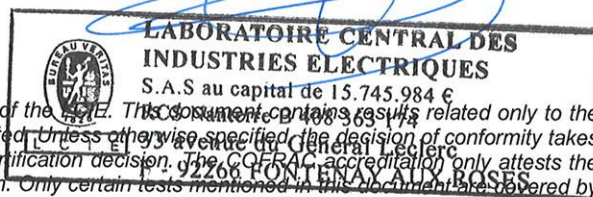

*This document shall not be reproduced, except in full, without the written approval of the LCIE. This document contains results related only to the item tested. It does not imply the conformity of the whole production to the items tested. Unless otherwise specified, the decision of conformity takes into account the uncertainty of measures. This document doesn't anticipate any certification decision. The COFRAC accreditation only attests the technical capability of the testing laboratory for the tests covered by the accreditation. Only certain tests mentioned in this document are covered by the accreditation. They are identified by the symbol (\*)*



## SUMMARY

1.	REFERENCE DOCUMENTS .....	3
2.	EQUIPMENT UNDER TEST DESCRIPTION .....	4
3.	SMARTVIEW MONITOR FUNCTIONAL DESCRIPTION ET OPERATING MODES .....	8
4.	TEST PROGRAM .....	9
5.	TRANSMITTER - FREQUENCY ERROR.....	11
6.	TRANSMITTER – EFFECTIVE RADIATED POWER OF FUNDAMENTAL EMISSION.....	13
7.	TRANSMITTER - EMISSION BANDWIDTH.....	15
8.	UNWANTED EMISSIONS - BAND EDGE COMPLIANCE- SPURIOUS RADIATION.....	17
9.	MEASUREMENT OF CONDUCTED DISTURBANCE: POWER SUPPLY .....	19
10.	SPECTRUM ACCESS .....	20
11.	MONITORING SYSTEM THRESHOLD POWER LEVEL .....	22
12.	MONITORING SYSTEM BANDWIDTH.....	23
13.	SCAN CYCLE TIME.....	24
14.	MINIMUM CHANNEL MONITORING PERIOD.....	25
15.	CHANNEL ACCESS .....	26
16.	DISCONTINUATION OF MEDRADIO SESSION .....	27
17.	ANNEX 1: UNCERTAINTIES CHART .....	28
18.	ANNEX 2 (GRAPHICS).....	29
19.	ANNEX 3 (TEST EQUIPMENT LIST).....	52

**1. REFERENCE DOCUMENTS**

- **47 CFR Part 15 of September 9, 2009:** Code of federal regulations – Telecommunication –Radiofrequency devices
  
- **Radio performance tests procedures given in part 15:**
  - Paragraph 33: frequency range of radiated measurements
  - Paragraph 35: measurement detector functions and bandwidths
  - Paragraph 203: antenna requirement
  - Paragraph 205: restricted bands of operation
  - Paragraph 207: conducted limits
  - Paragraph 209: radiated emission limits; general requirements
  
- **RSS-Gen of June 2007:** General Requirements and Information for the Certification of Radiocommunication Equipment
  
- **RSS-102 of November 2010:** Radio Frequency Exposure Compliance of Radiocommunication Apparatus
  
- **RSS-210 of June 2007 -** Low-power Licence-exempt Radiocommunication Devices (All Frequency Bands): Category I Equipment
  
- **RSS-243 of November 2005:** - Active Medical Implants Operating in the 402-405 MHz Band
  
- **ANSI C63.4 of December 11, 2003:** American national standard for methods of measurement of radio noise emissions from low-voltage electrical and electronic equipment in the range of 9 kHz to 40 GHz.
  
- **PART 95—PERSONAL RADIO SERVICES -** Equipment Description

**2. EQUIPMENT UNDER TEST DESCRIPTION**

The SmartView Monitor (SM) is intended to collect patient's clinical data from an Implantable Medical Device (IMD) and transfer them to data management system (Back Office server).

The IMD is implanted into the patient's body. The SmartView Monitor is installed at patient Home and is intended to collect data from the IMD remotely in absence of physician according to scheduled operation. It is not intended to act as emergency response system.

The connection between the SmartView Monitor and the implant is achieved through Radio-Frequency (RF) telemetry while the connection to the server is performed through the telephone line (fix or mobile net).

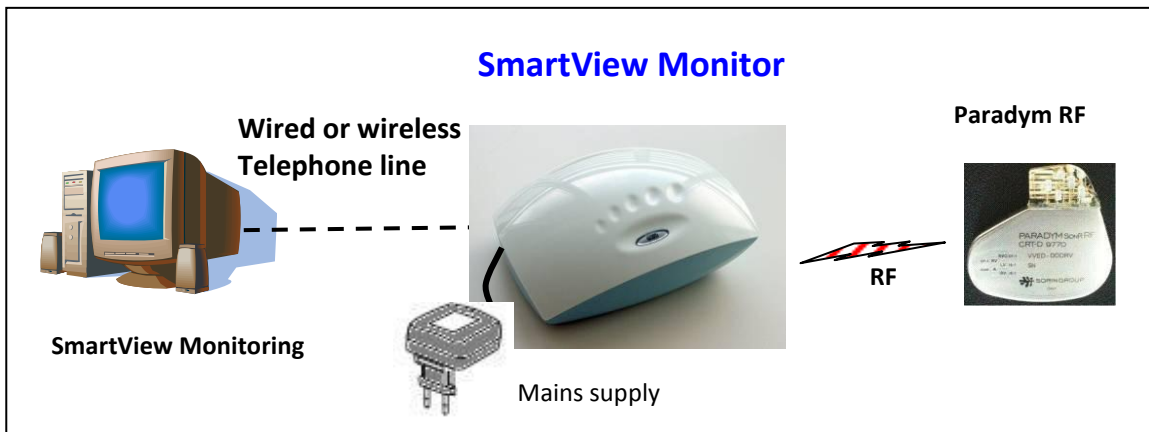

<b>Applicant</b>	<b>SORIN CRM</b> Parc d'affaires NOVEOS 4, Avenue Réaumur 92140 CLAMART Cedex
<b>Manufacturer</b>	<b>SELCO EOLANE COMBREE</b> Le Val d'Ombrée 49520 Combrée France
<b>Dimensions</b>	
<b>Frequencies band</b>	402-405 MHz 2400-2483 MHz
<b>Number of channel</b>	10 for 402-405 MHz band 15 for 2400-2483.5 band
<b>Channel spacing</b>	-
<b>Modulation</b>	FSK for 402-405 MHz band OOK for 2400-2483.5 band
<b>User power adjustment</b>	No
<b>Is the operation point to point?</b>	Yes
<b>Power supply</b>	Power Supply manufactured by FRIWO, model FW 7660M/05: 100-240V~ 50-60Hz 250mA, Output 5Vdc 1.6A
<b>I/O cables used for testing</b>	USB cable (only for test configuration) Telecommunication Cable (phone line)

Equipment photograph



Marking plate

Marking on PS



Marking on SMARTVIEW MONITOR

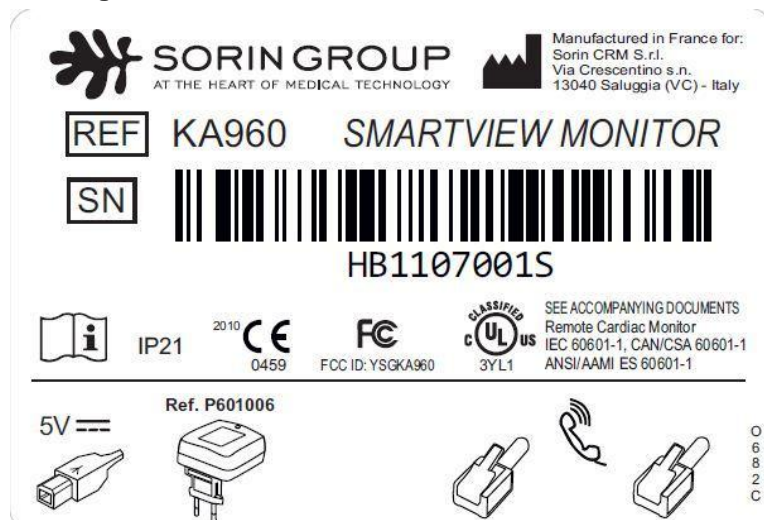



Block part	Description
<b>User interface</b>	<ul style="list-style-type: none"><li>- One pushbutton to allow the user to force a data transmission on demand,</li><li>- One status LED indicating overall system health,</li><li>- 5 LEDs showing the data collection and transmission progress</li></ul>
<b>RF</b>	<ul style="list-style-type: none"><li>- Unidirectional link from RM to implant in the ISM band (2.45 GHz) to wake up the implant. Chipcon CC2500 chip,</li><li>- Bidirectional link between the RM and the implant in the MEDRADIO band (402-405 MHz) for patient data transmission (Zarlink ZL70101 chip)</li></ul>
<b>Power Supply</b>	External 100-240V to 5V AC/DC adapter Power Supply manufactured by FRIWO, model FW 7660M/05: 100-240V~ 50-60Hz 250mA, Output 5Vdc 1.6A
<b>Ethernet module</b>	To be used in production for RM investigation
<b>Analog modem</b>	Mutitech MT56000 module, standard V92 SocketModem, telecom approved in 39 countries
<b>Processor</b>	Freescale MCIMX27L chip, ARM9-based 32-bit RISC
<b>Real time clock / Battery</b>	Maxim DS1391 RTC chip with a CR1620 backup lithium cell (60 mAh)
<b>USB cable</b>	Allow connection to the RM via USB
<b>Memory (DRAM, code, data &amp; boot FLASH)</b>	<ul style="list-style-type: none"><li>- DRAM memory: Micron MT46H16M16 chip, 32 MB DDR SDRAM memory</li><li>- Flash memories: Samsung K9F5608R0D chip, 32 MB NAND flash memory</li></ul>



**Antenna Type**

SmartView Monitor (Wake-up operating mode – ISM band):

-Monopole antenna (customized by Sorin CRM)

This antenna is internal and can not be removed.

- HP Max gain: -1dBi max

- VP Max gain: +2dBi max

-IFA antenna (customized by Sorin CRM)

This antenna is internal and can not be removed.

- HP Max gain: -6dBi max

- VP Max gain: -8dBi max

SmartView Monitor (Data transmission operating mode – MEDRADIO band)

This antenna is internal and can not be removed.

- HP Max gain: 1,4dBi max

- VP Max gain: 1,4dBi max



### 3. SMARTVIEW MONITOR FUNCTIONAL DESCRIPTION ET OPERATING MODES

In the following sections the SmartView Monitor is described, highlighting its Features and Operation.

Note: IMD is also described through this section as a slave of the SM.

#### **SmartView Monitor Operation**

The summary of mission / operation of the SmartView Monitor is the following:

- SM is a device to be installed in Patient Home.
  - Connection to power line (wall plug adapter)
  - Connection to telephone line (RTC version)
- SM shall be activated after connecting it to power supply. Executes:
  - bootstrap;
  - self-diagnostic;
  - implant pairing (at first boot)
- SM is paired through an automatic procedure to the Implant present at first boot
- SM shall collect patient's clinical data from Implanted device and transfer them to data management system (Back Office server).
- The Implant data collection shall be performed according to 3 use cases:
  - Scheduled Patient Home Follow-up
  - On Alert event/status evidenced by the Implant diagnostic features
  - On-Demand by Patient (if enabled)
- SM shall give indication to user about its correct operation and the function in progress:
  - SM health is ok (HW and code)
  - Patient should stay close to SM
  - Communication to IMD or BO is in progress
  - Error in IMD or BO communication

#### **SM Operating modes**

The SmartView Monitor is installed at patient Home in the context of RMS. The PSTN modem is connected to Back Office through the fix telephone line.

The SmartView Monitor communicates with the implanted device on two wireless RF bands:

- ISM band (2.45- GHz) for communication initialization (implant wake-up)
- MEDRADIO (402-405 MHz) band for data transfer

#### **IMD Operating modes**

The IMD communicates with the SmartView Monitor on two wireless RF bands:

- ISM band (2.45 GHz) for communication initialization (implant wake-up)
- MEDRADIO (402-405 MHz) band for data transfer

#### **IMD Hardware**

RF bi-band communication is done using the same ultra low consumption transceiver module connected through a stripe line and a hermetic bipolar feed-thru to a unique RF antenna loop embedded to the external connector of the device. The transceiver is driven by the CPU of the device upon dedicated interrupt request raised by the RF module.



**4. TEST PROGRAM****Transmitter requirement in 400 MHz band:**

Test Description	FCC	RSS 243	Test result	Remarks
- Frequency error	95.628(e)	3.3	Pass	
- Emission bandwidth	95.633(e)	3.2	Pass	
- Effective isotropic radiated power	95.639(f)	5.4	Pass	
- Unwanted Emissions – Band Edge Compliance	95.635(d)	3.4	Pass	
- Conducted emissions	15.207		Pass	

**Receiver requirement in 400 MHz band:**

Test Description	FCC	RSS 243	Test result	Remarks
– Spurious radiation	15.209	3.5	Pass	
– Monitoring system threshold power level	95.628(a) (3)	5.7.1	Pass	
– Monitoring system bandwidth	95.628 (a) (1)	5.7.2	Pass	
– Scan cycle time	95.628 (a) (2)	5.7.3	Pass	
– Minimum channel monitoring period	95.628 (a) (2)	5.7.4	Pass	
– Channel access	95.628 (a) (4)	5.7.5	Pass	
– Discontinuation of MEDRADIO session	95.628 (a) (4)	5.7.6 (f)	Pass	
– Use of pre-scanned alternate channel	95.628 (a) (5)	5.7.7	Pass	

Pass: EUT complies with standard's requirement

Fail: EUT does not comply with standard's requirement

N/A: Not Applicable

## 5. TRANSMITTER - FREQUENCY ERROR

### 5.1. TEST CONDITIONS

Test performed by : Stéphane Phoudiah  
Date of test : 2011/05/09  
Ambient temperature : 20°C  
Relative humidity : 40%

### 5.2. TEST SETUP

The test is performed on EUT in permanent emission without modulation on 402,15MHz; 403,65MHz and 404,85MHz.

#### Qualification measurements in a climatic chamber

For measurement under normal and extreme test conditions, the Equipment under Test is installed in the climatic chamber. A test fixture has been used.



**5.3. TEST SEQUENCE AND RESULTS****Method of measurement** FCC 95.628(e) – RSS 243 §3.3

Temperature	Channel	0°C	+20°C	+55°C
<b>Voltage: 253V, 230V &amp; 207V</b> Frequency Drift (kHz)	Fmin	9	0	-14
<b>Voltage: 253V, 230V &amp; 207V</b> Frequency Drift (kHz)	Fo	-6	0	8
<b>Voltage: 253V, 230V &amp; 207V</b> Frequency Drift (kHz)	Fmax	-6	0	8

See graphics N°1 to N°9 in annex 2

**Limit:** → 402 MHz to 405 MHz band shall not exceed  $\pm 100$  ppm ( $\pm 40,32$  kHz)

**Result:** Maximum frequency drift measured is 14kHz when the temperature is varied from 0°C to +55°C and when the power voltage is varied from 207 Vac to 253 Vac.

**5.4. CONCLUSION**

Frequency error test performed on the sample "SMARTVIEW MONITOR KA960" show levels below the FCC 95.628(e) limits.

## 6. TRANSMITTER – EFFECTIVE RADIATED POWER OF FUNDAMENTAL EMISSION

### 6.1. TEST CONDITIONS

Test performed by : Stéphane Phoudiah  
Date of test : 2011/05/02  
Ambient temperature : 22°C  
Relative humidity : 34%

### 6.2. TEST SETUP

The test is performed on EUT in permanent emission without modulation on 402,15MHz; 403,65MHz and 404,85MHz.

#### Method of measurement

FCC 95.639(f) – RSS 243 § 5.4

#### Configuration

RF field:  Unmodulated  
 Modulated

#### Qualification measurements in the 3 meters full anechoic chamber

The setup is 1.5m above the ground reference plane on a wooden table. Distance between measuring antenna and the EUT is 3 meters. The measuring antenna is in vertical and then in horizontal polarization. Continuous linear turntable azimuth search was performed with 360 degrees range. The substitution antenna replaces the equipment under test for Effective Radiated Power (ERP) measurement. Power is measured for the same level of radiated field strength obtained on the measuring antenna.

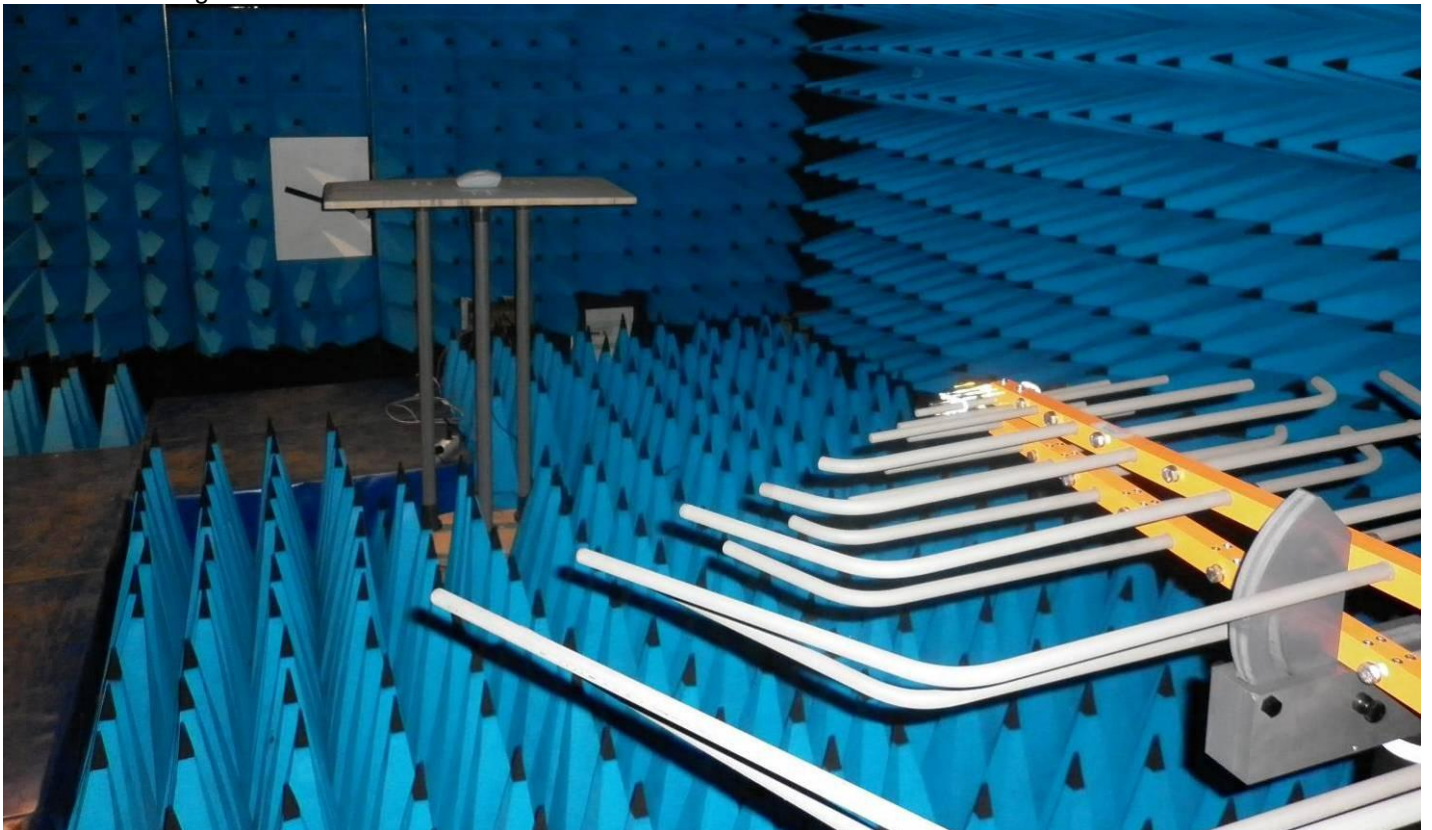





### 6.3. TEST SEQUENCE AND RESULTS

#### **Measurement result under normal test conditions:**

Measurements are performed in normal test conditions. The measuring bandwidth of the spectrum analyzer is 120 kHz and the detector type is Peak.

#### **Result:**

Channel	Frequency (MHz)	EIRP (dBm) Vertical polarization	EIRP ( $\mu$ W) Vertical polarization	Limit (dBm or $\mu$ W)	Comments
Fmin	402,15	-19,94	10,14	-16 dBm or 25 $\mu$ W	Pass
F0	403,65	-19,66	10,81	-16 dBm or 25 $\mu$ W	Pass
Fmax	404,85	-19,46	11,32	-16 dBm or 25 $\mu$ W	Pass

### 6.4. CONCLUSION

Effective Radiated Power test, performed on the sample "SMARTVIEW MONITOR KA960" show levels below the FCC 95.639(f) – RSS 243 §5.4 limits.

## 7. TRANSMITTER - EMISSION BANDWIDTH

### 7.1. TEST CONDITIONS

Test performed by : Stéphane Phoudiah  
Date of test : 2011/05/02  
Ambient temperature : 21°C  
Relative humidity : 34%

### 7.2. TEST SETUP

The test is performed on EUT in permanent emission with modulation on 402,15MHz; 403,65MHz and 404,85MHz.

#### Method of measurement

Emission bandwidth FCC 95.633(e) or RSS 243 §3.2

#### Qualification measurements on a table

Emission bandwidth is measured with a spectrum analyzer on the EUT RF conducted access.





Channel	Frequency (MHz)	Emission Bandwidth (kHz)	Limit (kHz)	Comments
Fmin	402,15	211,6	300	Pass
F0	403,65	207,6	300	Pass
Fmax	404,85	211,6	300	Pass

**7.3. TEST SEQUENCE AND RESULTS****Normal test****conditions – Transmitter modulation bandwidth**

The transmitter range of modulation bandwidth is measured 20dB below the peak power.

**Result:**

See graphics N°10 to N°12 in annex 2

**7.4. CONCLUSION**

Modulation bandwidth test performed on the sample "SMARTVIEW MONITOR KA960" show levels below the FCC 95.633(e) or RSS 243 §3.2 limits.



**8. UNWANTED EMISSIONS - BAND EGDE COMPLIANCE- SPURIOUS RADIATION****8.1. TEST CONDITIONS**

Test performed by : Stéphane Phoudiah  
Date of test : 2011/06/14  
Ambient temperature : 21°C  
Relative humidity : 32%

**8.2. TEST SETUP**

The test is performed on EUT in permanent emission with modulation on 402,15MHz; 403,65MHz and 404,85MHz.

**Method of measurement**

- Unwanted emission FCC 95.633(d) or RSS 243 §3.2
- Out of-band emission: FCC 95.635(d)(1) or RSS 243 §3.2
- In band emission: FCC 95.635(d)(4) or RSS 243 §3.2

**Characterization in semi-anechoic chamber (30MHz to 5 GHz):**

The setup is 1.5m above the ground reference plane on a wooden table.  
Distance between measuring antenna and the EUT is 3 meters.  
The measuring antenna is in vertical and then in horizontal polarization. Measurement bandwidth was 100 kHz.  
Continuous linear turntable azimuth search was performed with 360 degrees range.

**8.3. TEST SEQUENCE AND RESULTS****Normal test conditions – Unwanted emission – Spurious radiation****Characterization in semi-anechoic chamber (30MHz to 5 GHz):**

Frequency (MHz)	Measure (dBµV/m)	Limit (dBµV/m)
30.1	28.3	40
42.5	24.5	40
43.7	26.1	40
66.4	21.9	40
88.6	26.8	43.5
91.1	29.8	43.5
94.2	27.7	43.5
96	29.3	43.5
98.5	30.2	43.5
100.6	29.1	43.5
100.9	28.8	43.5
182.1	28.5	43.5
233.8	30.1	46
1885.2	37.1	53.5
2367	38.6	53.5
2128	35.5	53.5
2284	48.9	53.5
2362	46.1	53.5
2381	42.6	53.5
2518	47.1	53.5
2596	45.6	53.5
2615	42.1	53.5
5366	39.7	53.5

See graphics N°13 to N°15 in annex 2



**Limit FCC 95.635 (d)(1) and FCC 15.209**

Frequency (MHz)	Field strength (µV/m)	Measurement distance (m)
30 à 88	100	3
88 à 216	150	3
216 à 960	200	3
> 960	500	3

**Normal test conditions – In band emission**

The “In band emission” is measured 20dB below the peak power.

Channel	Measure (kHz)	Limit (kHz)	Comments
Fmin	102,8	150	Pass
F0	103,8	150	Pass
Fmax	104,8	150	Pass

**Limit FCC 95.635(d)(4)**

Emissions within the MEDRADIO band (402 – 405 MHz) more than 150 kHz away from the center frequency of the spectrum the transmission is intended to occupy will be attenuated below the transmitter output power by at least 20 dB.

**Normal test conditions – Band-edge emission**

The “Band edge emission” is measured 20dB below the peak power.

Channel	Measure (MHz)	Limit (MHz)	Comments
Fmin	402,05	Above 401,75	Pass
Fmax	404,96	Below 405,25	Pass

See graphics N°10 and N°12 in annex 2

**Band-edge emissions: FCC 95.635(d)(5)**

Emissions 250 kHz or less that are above and below the MEDRADIO band (402 – 405 MHz) will be attenuated below the maximum permitted output power by at least 20 dB (-16 dBm or 25 µW e.i.r.p.).

**8.4. CONCLUSION**

Unwanted emission, spurious radiation and band edge emission tests performed on the sample “SMARTVIEW MONITOR KA960” show levels below the FCC limits.

**9. MEASUREMENT OF CONDUCTED DISTURBANCE: POWER SUPPLY**

Specifications	
Test method according <b>FCC Part 15 (2009)</b>	FCC Part 15.207
Frequency	0.15 – 30 MHz
Limit	See summary table <span style="float: right;">Power supply : Class B</span>
Detector	Peak , Quasi Peak and average <span style="float: right;">RBW 9 kHz</span>

Operating conditions	
Comments	The measurement is performed on power supply with a LISN and telecommunication lines with RSI or current clamp for shielded cables.
Equipment list	See at the end of the paragraph
Deviation method	No
Product installation	The EUT is installed on a wooden table 80 cm above the reference plane, 40 cm from vertical plane, at 80cm of the LISN.
Operating mode	Nominal

**Conclusion**  
**The product is compliant with the standard**

Measure on main power supply			
Line	Operating mode	Graphics	Comments
Phase	Nominal	N°16	Pass
Neutral	Nominal	N°17	Pass

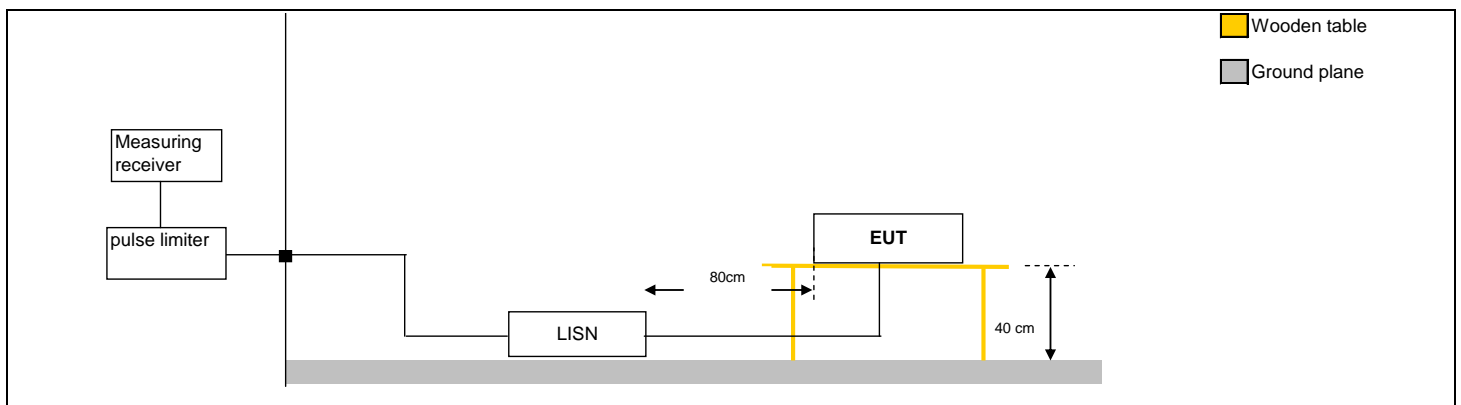

**Test set up of conducted emission on power supply**

**10. SPECTRUM ACCESS**

**10.1. TEST CONDITIONS**

Test performed by : Stéphane PHOUDIAH  
 Date of test : 2011/05/05 and 2011/05/06  
 Ambient temperature : 22°C  
 Relative humidity : 37%

**10.2. TEST SETUP**

**Method of measurement**

For these tests, a blocking band was created using 10 signal generators and transmits by antenna or by conduction.

Frequency	(MHz)
F0	402,15
F1	402,45
F2	402,75
F3	403,05
F4	403,35
F5	403,65
F6	403,95
F7	404,25
F8	404,55
F9	404,85

*A spectrum analyzer (listed in test equipment list) is used to adjust the level and the frequency. For traceability, this analyzer is the reference for level and frequency generated from 9 signals used for this test.*

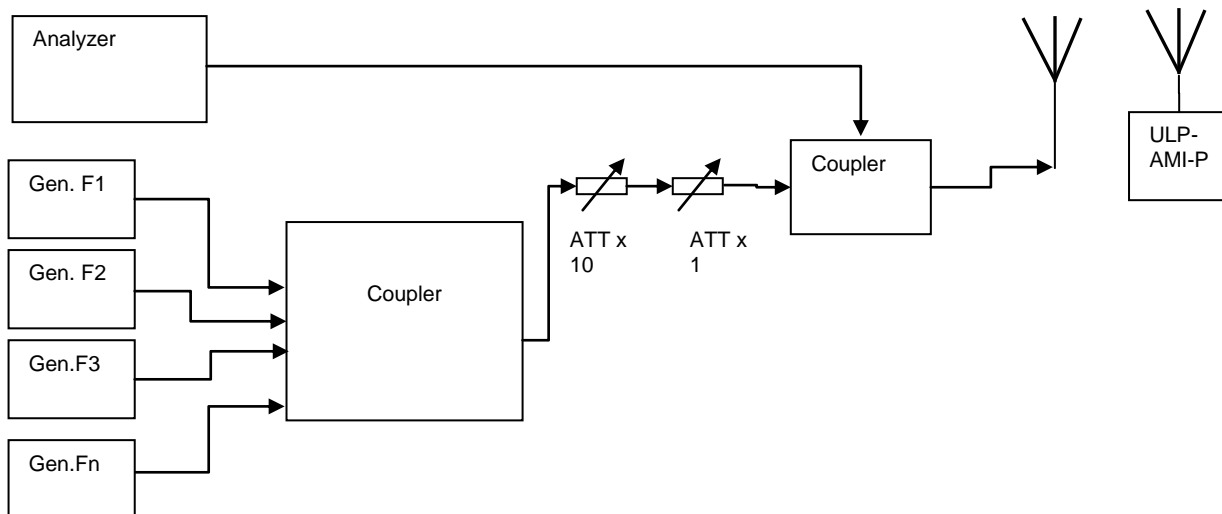

**Spectrum access test set up**

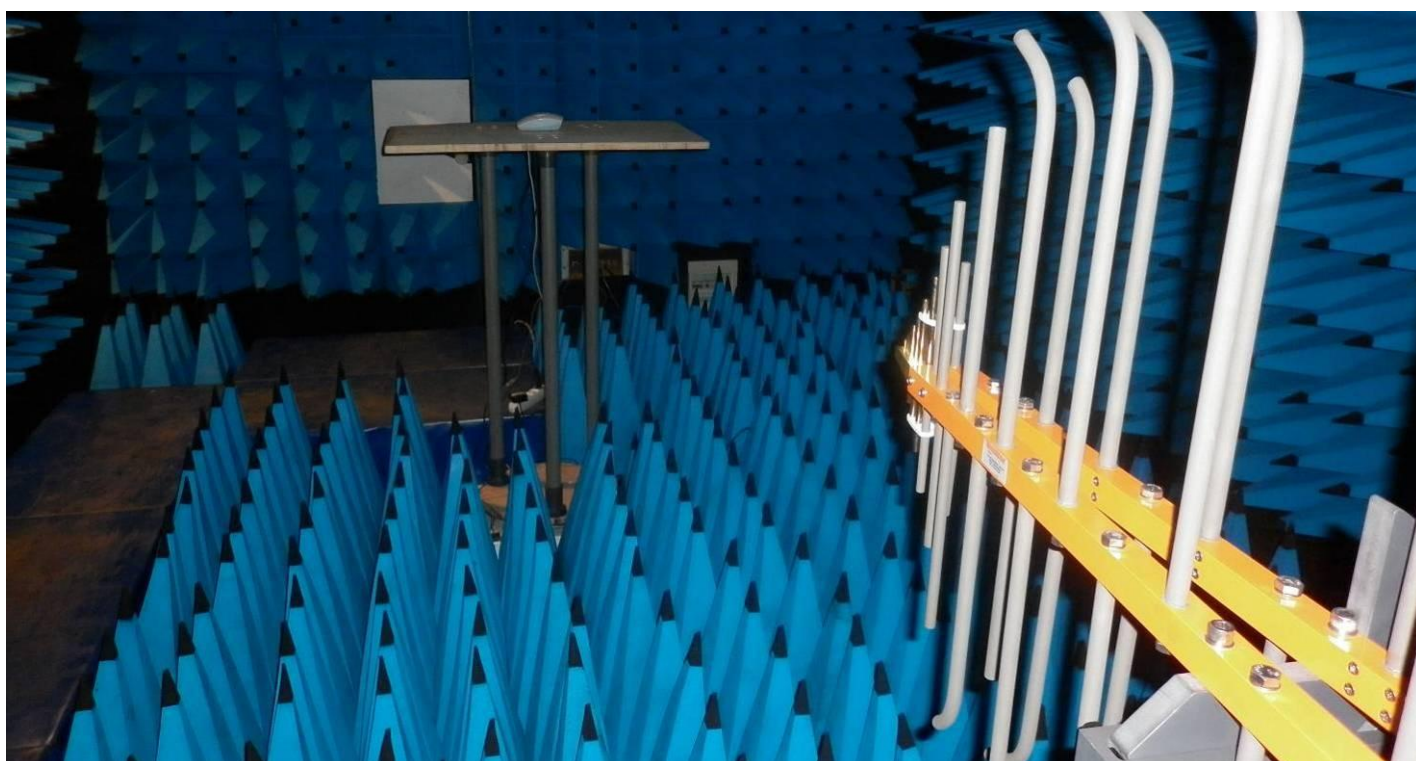

**11. MONITORING SYSTEM THRESHOLD POWER LEVEL**

**11.1. TEST CONDITIONS**

Test performed by : Stéphane PHOUDIAH  
 Date of test : 2011/05/05 and 2011/05/06  
 Ambient temperature : 22°C  
 Relative humidity : 37%

**11.2. TEST SETUP**

**Method of measurement**

For these tests, a blocking band was created using 10 signal generators and transmits by antenna.

**FCC 95.628 (a) (3)**

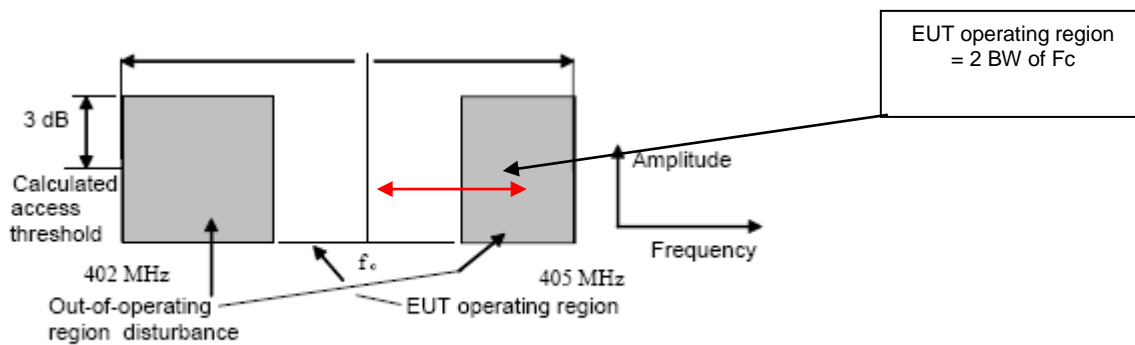

Figure 1: Spectrum Mask for Test of clauses 10.1.1 and 10.1.2

The monitoring system threshold power level,  $Thp$  shall not be greater than the calculated level given by the equation:

$$Thp = 10 \log B(\text{Hz}) - 150 \text{ (dBm/Hz)} + G \text{ (dBi)}$$

Emission Bandwidth (Hz)	Antenna gain (dBi)	Pth (dBm)
213600	1,4	-95,4

**11.3. CONCLUSION**

Monitoring system threshold power level test performed on the sample "SMARTVIEW MONITOR KA960" show levels below the FCC 95.628 (a) (3) limits.

**12. MONITORING SYSTEM BANDWIDTH****12.1. TEST CONDITIONS**

Test performed by : Stéphane PHOUDIAH  
Date of test : 2011/05/05 and 2011/05/06  
Ambient temperature : 22°C  
Relative humidity : 37%

**12.2. TEST SETUP****Method of measurement**

For these tests, a blocking band was created using 10 signal generators and transmits by antenna.

**FCC 95.628 (a) (1)**

The intent of this requirement is to insure that the EUT measures the power in a bandwidth that is equal to or greater than the emission bandwidth of the transmitter with the widest emission that it will participate with in a MEDRADIO communications session.

Measure of bandwidth where a channel is occupied, the bandwidth should be at least so big as the emission bandwidth.

**Bandwidth = 207,6 kHz**

**12.3. RESULTS****Result:**

	Frequency (MHz)	Interferer level (dBm)
Fc	403,65	-90
Flow	403,5472	-90
Fhigh	404,7528	-78

	Level (dB)	Limit (dB)	Comments
PFlow- PFc	0	20	Pass
PFhigh-PFc	12	20	Pass

See graphics N°18 to N°20 in annex 2

**12.4. CONCLUSION**

Monitoring system bandwidth test performed on the sample "SMARTVIEW MONITOR KA960" show levels below the FCC 95.628 (a) (1) limits.

**13. SCAN CYCLE TIME****13.1. TEST CONDITIONS**

Test performed by : Stéphane PHOUDIAH  
Date of test : 2011/05/05 and 2011/05/06  
Ambient temperature : 22°C  
Relative humidity : 37%

**13.2. TEST SETUP****Method of measurement**

For these tests, a blocking band was created using 10 signal generators and transmits by antenna.

**FCC 95.628 (a) (2)**

The intent of this requirement is to ensure that the monitoring system updates the detected power levels by scanning the ULP-AMI band at a rate less 5s. Within 5s prior to initiating a communication session, circuitry associated with medical implant programmer/control transmitter shall monitor the channels.

This test is done 4 times

**13.3. RESULTS**

Frequency (MHz)	Scan cycle time (s)	Limit (s)	Comments
403,65	1,19	5	Pass

See graphic N°21 in annex 2

**13.4. CONCLUSION**

Monitoring system scan cycle time test performed on the sample "SMARTVIEW MONITOR KA960" show levels below the FCC 95.628 (a) (2) limits.



**14. MINIMUM CHANNEL MONITORING PERIOD****14.1. TEST CONDITIONS**

Test performed by : Stéphane PHOUDIAH  
Date of test : 2011/05/05 and 2011/05/06  
Ambient temperature : 22°C  
Relative humidity : 37%

**14.2. TEST SETUP****Method of measurement**

For these tests, a blocking band was created using 10 signal generators and transmits by conduction.

**FCC 95.628 (a) (2)**

The intent of this requirement is to ensure that the monitoring period on each channel is 10ms or longer to detect transmissions that may have silent periods between data that are less than 10ms in duration.

**Minimum channel monitoring period:**

all channels occupied, except Channel Fc → Level shall be > 3dB than Threshold Power Level  
Channel 9 with pulsed Interferer → Pulse 100µs on, 9,9ms off

**14.3. RESULTS**

The communication is performed on the Channel 9.

**Result: Pass**

**See graphic N°22 in annex 2**

**Limit:** The EUT should not initiate a communication session on a frequency different from channel Fc

**14.4. CONCLUSION**

**Minimum channel monitoring period test performed on the sample "SMARTVIEW MONITOR KA960" show levels above the FCC 95.628 (a) (2) limits.**

**15. CHANNEL ACCESS****15.1. TEST CONDITIONS**

Test performed by : Stéphane PHOUDIAH  
Date of test : 2011/05/05 and 2011/05/06  
Ambient temperature : 22°C  
Relative humidity : 37%

**15.2. TEST SETUP****Method of measurement**

For these tests, a blocking band was created using 10 signal generators and transmits by antenna.

**FCC 95.628 (a) (4)**

MEDRADIO programmer/control transmitters are permitted to initiate a connection to an implant transmitter if the ambient signal level is below the maximum permitted threshold. If no channel is available with an ambient power level at or below the maximum permitted threshold, spectrum access is permitted based on the channel with the lowest ambient power level referred to as the LIC or "Least interfered channel".

Check, whether the channel disturbed least is selected if all channels are occupied.  
All channels are occupied except channel Fc. Channel 2 shall be 3dB above the Threshold Power  
All other channels shall be 10dB above the Threshold Power Level.  
Level of continuous Interferer adjusts on channel Fc, 3dB below the Threshold Power Level;  
Level of continuous Interferer increases at 9dB on channel Fc;

**15.3. RESULTS**

The communication switched on the least interfered channel (Channel 2) after the 9dB increasing level of Fc

**Result: Pass**

**See graphic N°23 in annex 2**

**Limit:** The EUT should access and transmit on the least interfered channel after the 9dB increasing level of Fc

**15.4. CONCLUSION**

**Channel Access test performed on the sample "SMARTVIEW MONITOR KA960" show levels below the FCC 95.628 (a) (4) limits.**

**16. DISCONTINUATION OF MEDRADIO SESSION****16.1. TEST CONDITIONS**

Test performed by : Stéphane PHOUDIAH  
Date of test : 2011/05/05 and 2011/05/06  
Ambient temperature : 22°C  
Relative humidity : 37%

**16.2. TEST SETUP****Method of measurement**

For these tests, a blocking band was created using 10 signal generators and transmits by antenna.

**FCC 95.628 (a) (4)**

MEDRADIO system shall cease transmission in the event that the communication session is interrupted for a period of 5s or more.

Check, whether communication switching off, after 5s break  
All channels are occupied, except channel 2.  
Measure time up to communication switching off.

**16.3. RESULTS**

Discontinuation of MEDRADIO session (s)	Limit (s)	Comments
4,5	5	Pass

**16.4. CONCLUSION**

Discontinuation of MEDRADIO session test performed on the sample "SMARTVIEW MONITOR KA960" show levels below the FCC 95.628 (a) (4) limits.



**17. ANNEX 1: UNCERTAINTIES CHART**

**Maximum measurement uncertainties**

<i>Kind of test</i>	<i>Wide uncertainty laboratory (k=2) ±x(dB) / (Hz)</i>	<i>uncertainty limit ±y(dB)</i>
<b>TRANSMITTER REQUIREMENTS</b>		
<i>Frequency error</i>	±10kHz	
<i>Carrier power (conducted)</i>		±4 dB
<i>Effective radiated Power</i> <ul style="list-style-type: none"> <li>• <i>Frequency &lt; 1000 MHz</i></li> <li>• <i>Frequency &gt; 1000 MHz</i></li> </ul>	±5.72 dB ±5.69 dB  ±5.72 dB ±5.69 dB	±6 dB
<i>Frequency deviation</i>		
<i>Modulation Depth</i>		
<i>Adjacent channel power</i>		±3 dB
<i>Range of modulation bandwidth for wide band equipment</i>		
<i>Spurious emissions (§8.7)</i> <ul style="list-style-type: none"> <li>• <i>Frequency &lt; 1000 MHz</i></li> <li>• <i>Frequency &gt; 1000 MHz</i></li> </ul>	±5.72 dB ±5.46 dB  ±5.72 dB ±5.46 dB	±6 dB
<i>Frequency stability under low-voltage conditions</i>	±2.10 <sup>-8</sup> Hz	±1.10 <sup>-7</sup> Hz
<i>Duty cycle</i>	--	--
<b>RECEIVER REQUIREMENTS</b>		
<i>Adjacent channel selectivity-in band</i>	±2.89 dB	--
<i>Adjacent band selectivity</i>	±2.89 dB	--
<i>Blocking or desensitization</i>	±2.89 dB	--
<i>Spurious emissions (§9.4)</i> <ul style="list-style-type: none"> <li>• <i>Frequency &lt; 1000 MHz</i></li> <li>• <i>Frequency &gt; 1000 MHz</i></li> </ul>	±5.72 dB ±5.46 dB  ±5.72 dB ±5.46 dB	±6 dB

**18. ANNEX 2 (GRAPHICS)**

Graphic N°1  
 Frequency error  
 207Vdc, 230Vdc & 253Vdc  
 402,15MHz  
 0°C



\* Att 10 dB                      \* RBW 300 Hz                      **M1[1]**                      **-17.50 dBm**  
 Batt Ref -10.0 dBm              VBW 1 kHz                      **402.15600000 MHz**  
 SWT 5.6s

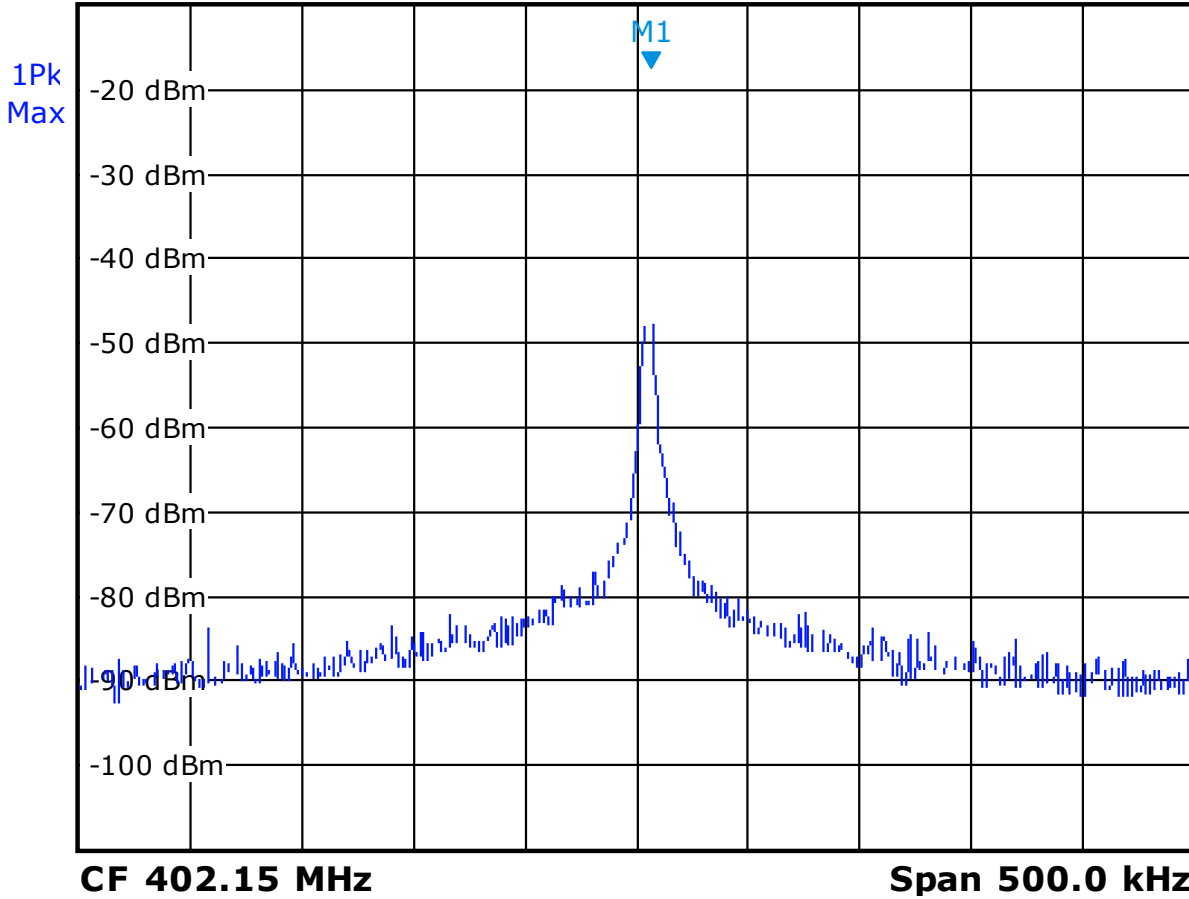



Graphic N°2  
Frequency error  
207Vdc, 230Vdc & 253Vdc  
403,65MHz  
0°C



\* Att 10 dB                      \* RBW 300 Hz                      M1[1]                      -17.74 dBm  
Batt Ref -10.0 dBm                      VBW 1 kHz                      403.64800000 MHz  
SWT 5.6s

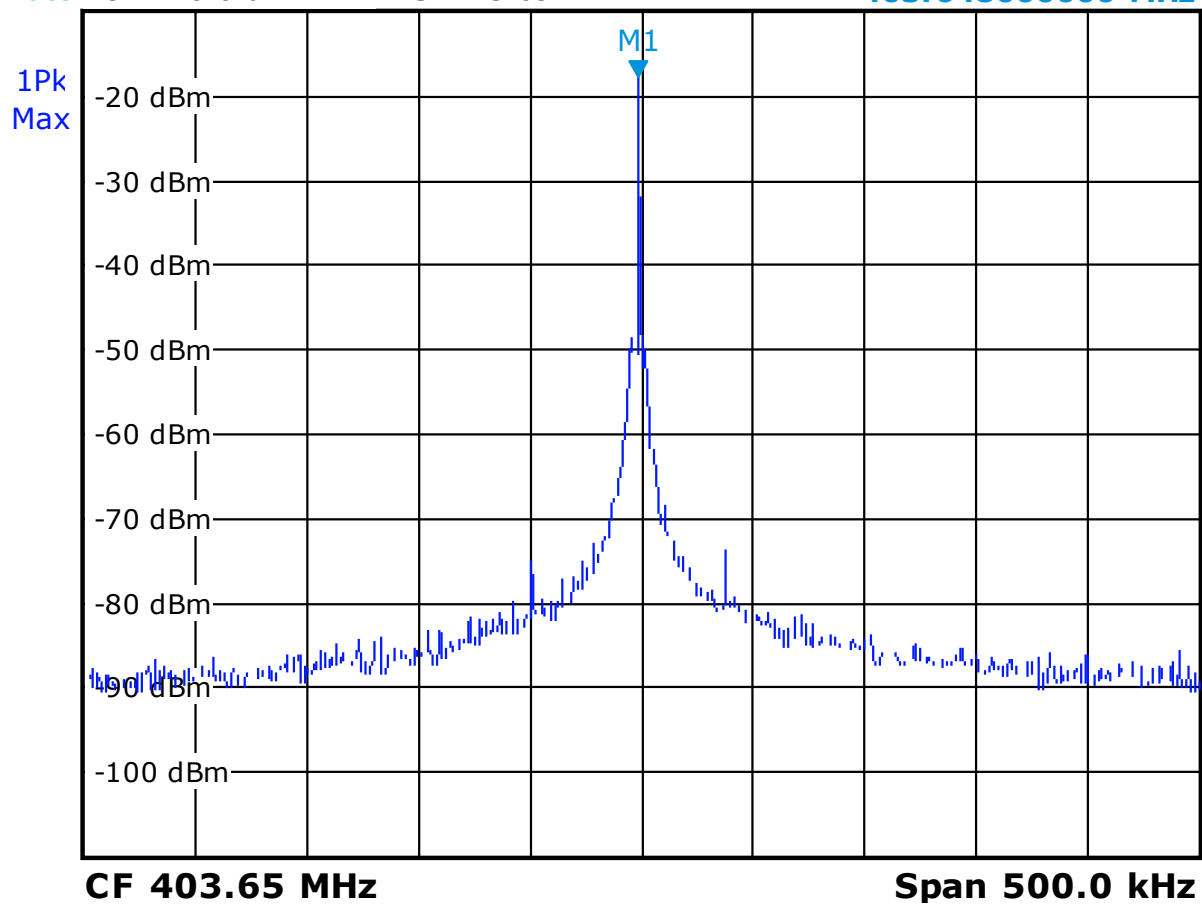



L C I E

Graphic N°3  
Frequency error  
207Vdc, 230Vdc & 253Vdc  
404,85MHz  
0°C



\* Att 10 dB                      \* RBW 300 Hz  
Batt Ref -10.0 dBm              VBW 1 kHz                      M1[1]                      -17.77 dBm  
SWT 5.6s                              404.84800000 MHz

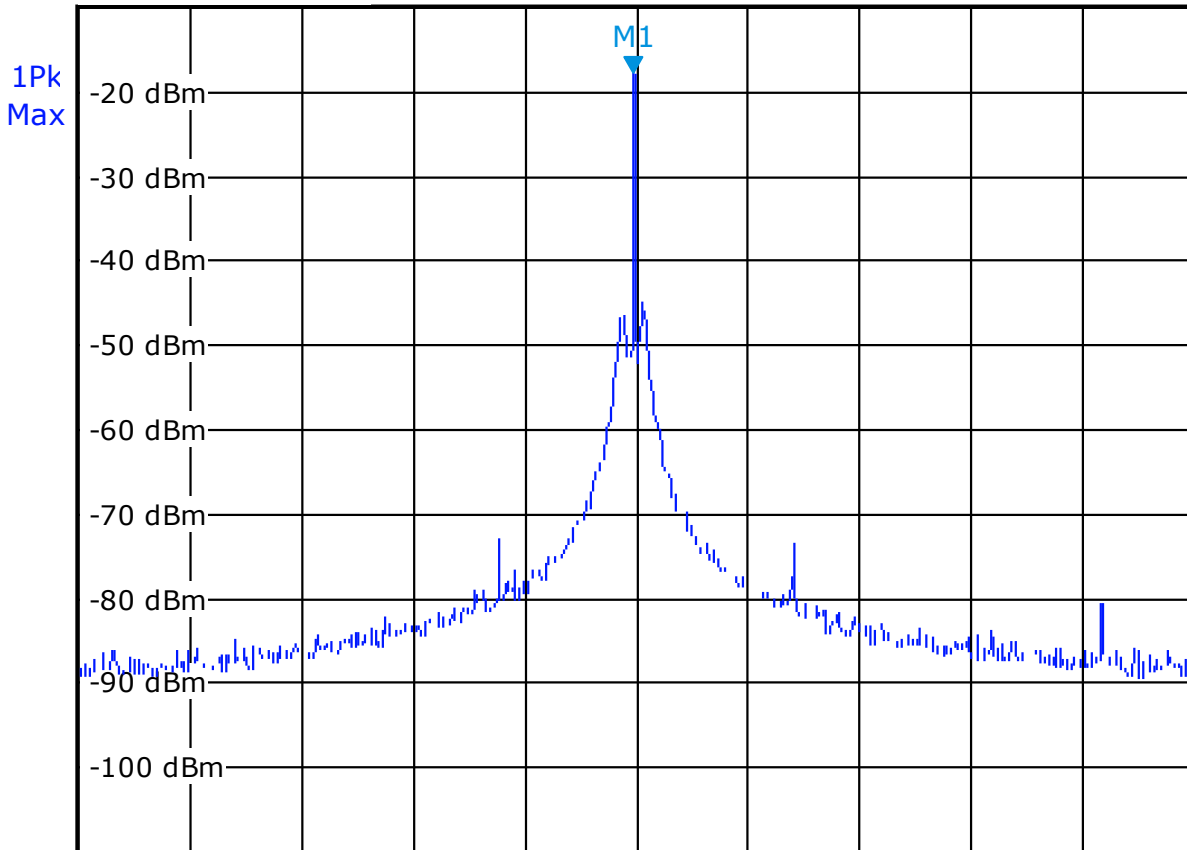

CF 404.85 MHz

Span 500.0 kHz



Graphic N°4  
Frequency error  
207Vdc, 230Vdc & 253Vdc  
402,15MHz  
20°C



\* Att 10 dB                      \* RBW 300 Hz                      **M1[1]**                      **-18.38 dBm**  
Batt Ref -10.0 dBm                      VBW 1 kHz                      **402.14700000 MHz**  
SWT 5.6s

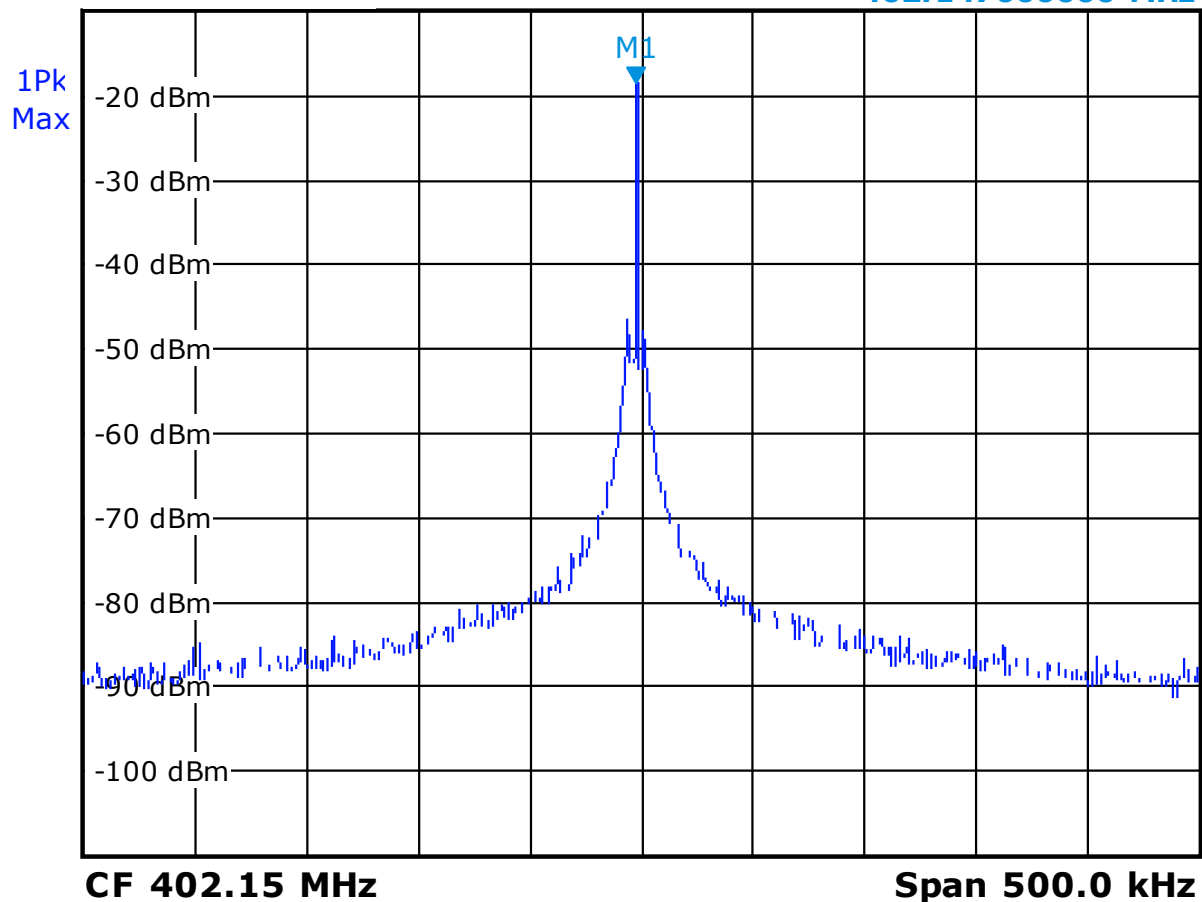





Graphic N°5  
Frequency error  
207Vdc, 230Vdc & 253Vdc  
403,65MHz  
20°C



\* Att 10 dB                      \* RBW 300 Hz  
Batt Ref -10.0 dBm              VBW 1 kHz                      M1[1]                      -18.61 dBm  
SWT 5.6s                              403.65400000 MHz

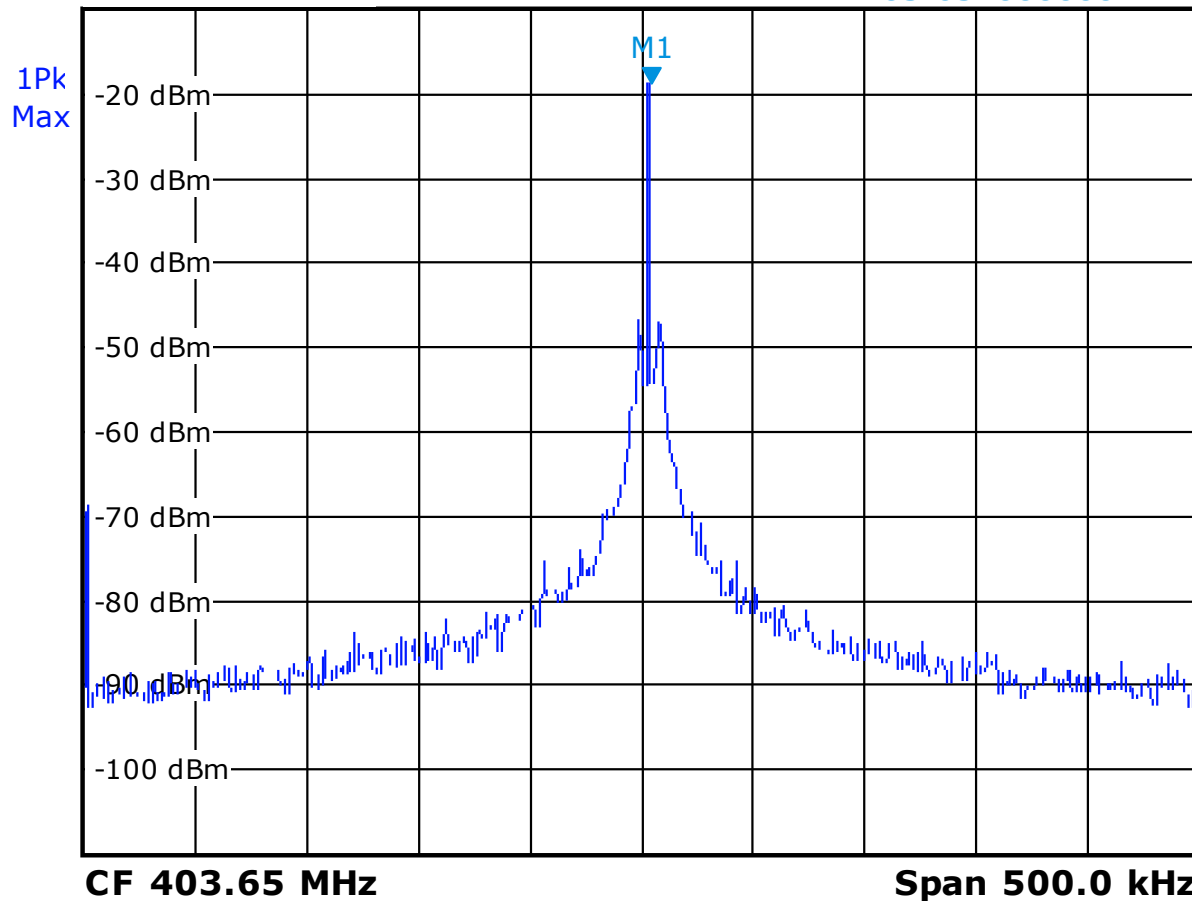



Graphic N°6  
Frequency error  
207Vdc, 230Vdc & 253Vdc  
404,85MHz  
20°C



\* Att 10 dB                               \* RBW 300 Hz                               M1[1]                               -18.77 dBm  
Batt Ref -10.0 dBm                       VBW 1 kHz                               404.85400000 MHz  
SWT 5.6s

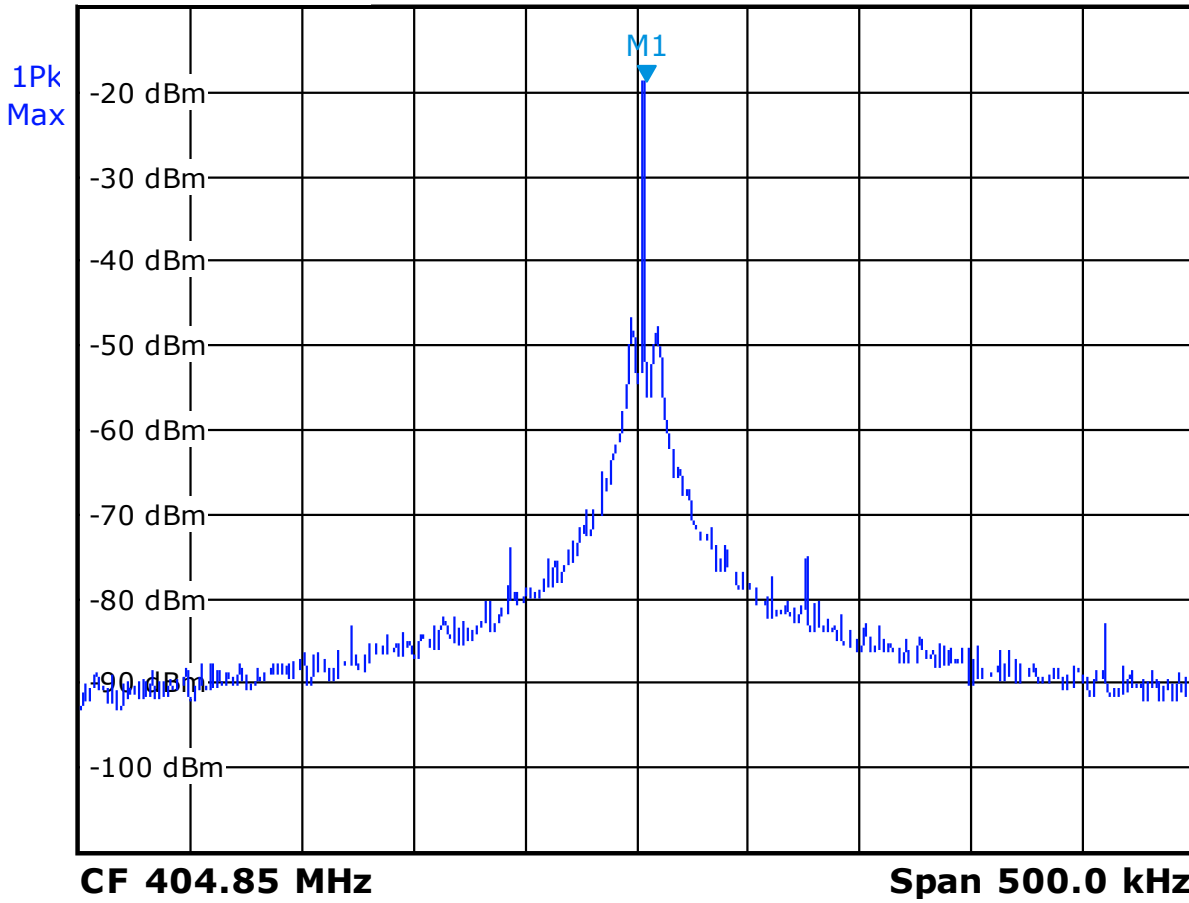



Graphic N°7  
Frequency error  
207Vdc, 230Vdc & 253Vdc  
402,15MHz  
55°C



\* Att 10 dB                      \* RBW 300 Hz                      **M1[1]**                      **-19.92 dBm**  
Batt Ref -10.0 dBm              VBW 1 kHz                      **402.13300000 MHz**  
SWT 5.6s

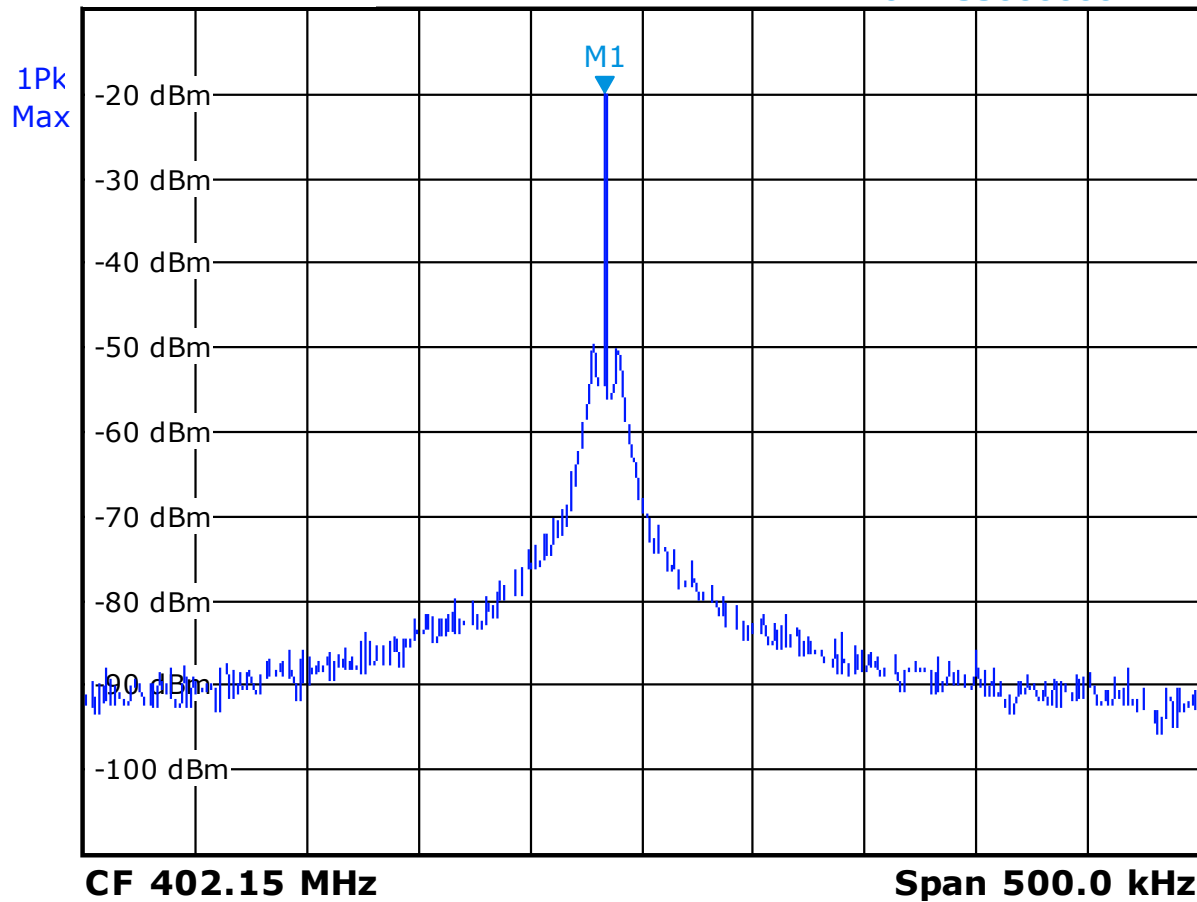



L C I E

TEST REPORT N°106440-611204-E-Cr-2012-01-10

Graphic N°8  
Frequency error  
207Vdc, 230Vdc & 253Vdc  
403,65MHz  
55°C



\* Att 10 dB                    \* RBW 300 Hz                    M1[1]                    -19.96 dBm  
Batt Ref -10.0 dBm            VBW 1 kHz                    403.66200000 MHz  
SWT 5.6s

1Pk  
Max

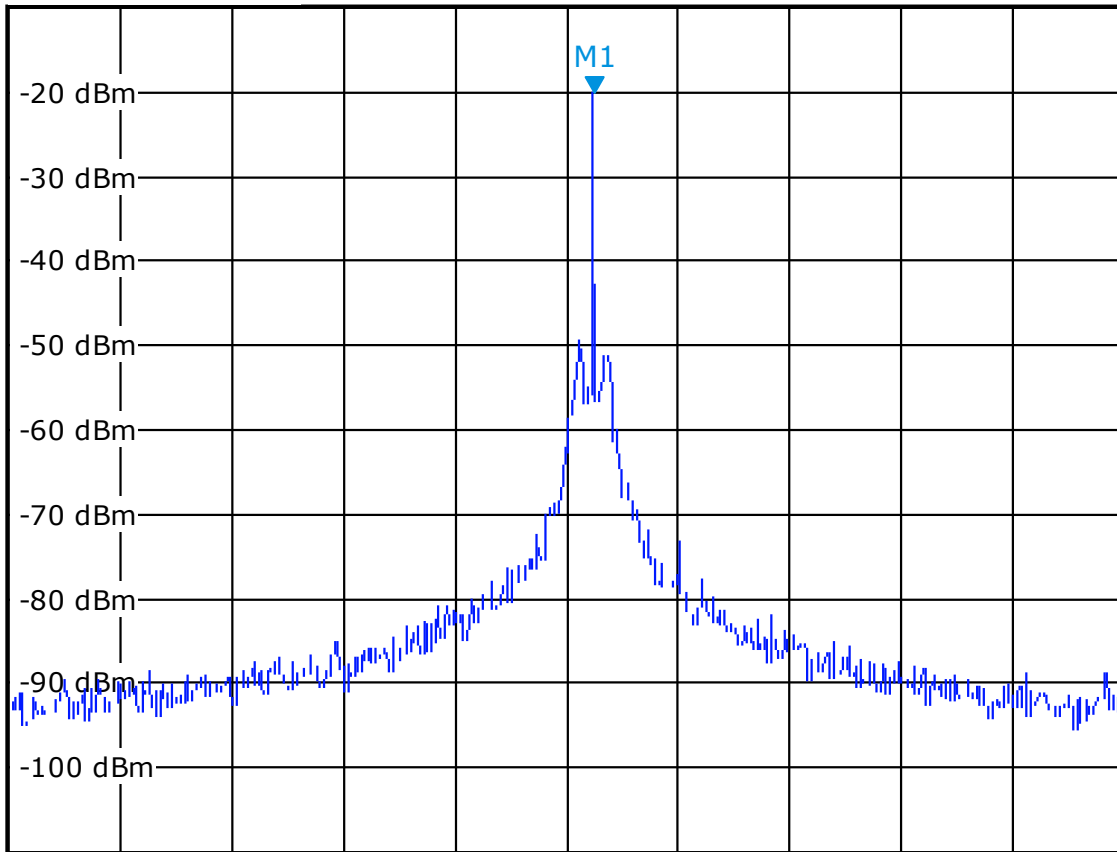

CF 403.65 MHz

Span 500.0 kHz



Graphic N°9  
Frequency error  
207Vdc, 230Vdc & 253Vdc  
404,85MHz  
55°C



\* Att 10 dB                      \* RBW 300 Hz  
Batt Ref -10.0 dBm              VBW 1 kHz                      M1[1]                      -20.22 dBm  
    SWT 5.6s                      404.86200000 MHz

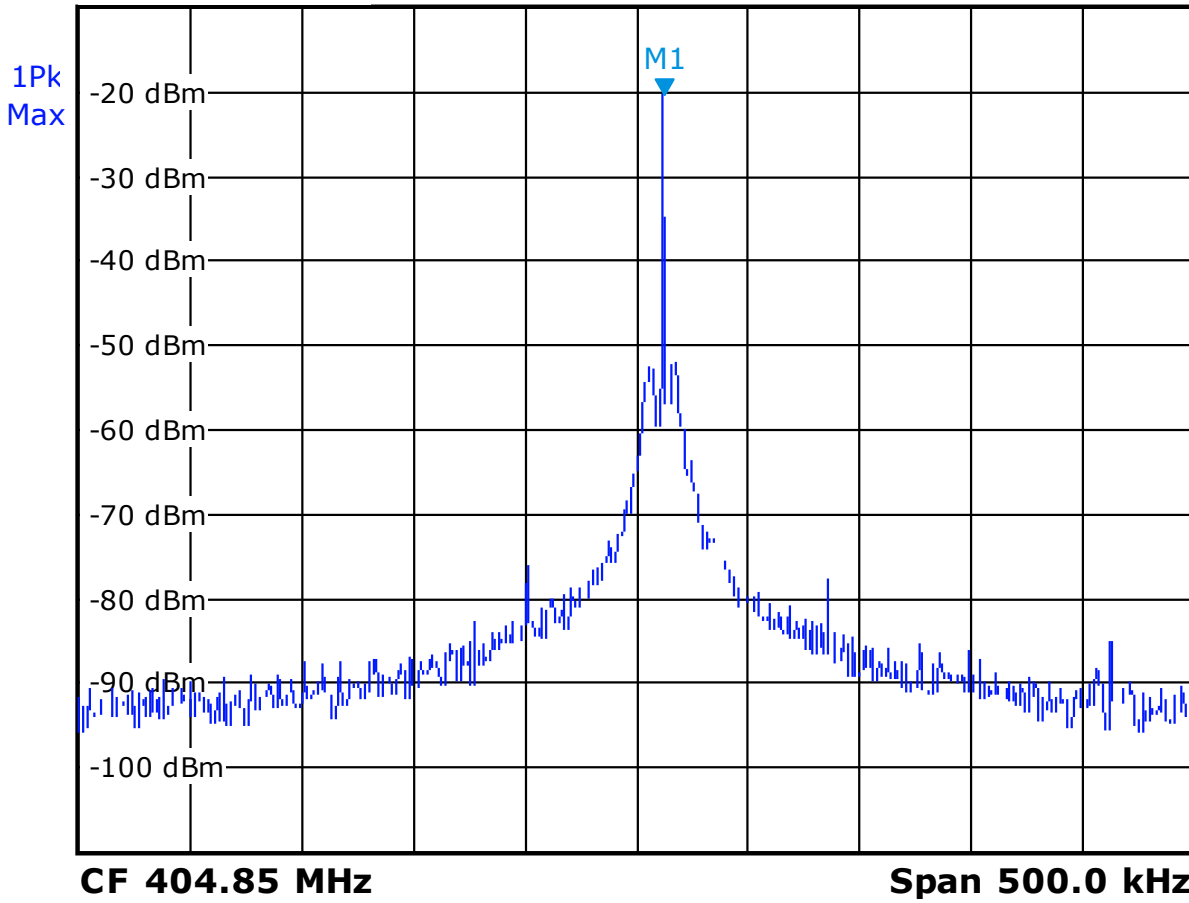



Graphic N°10  
Emission Bandwidth  
230Vdc  
402,15MHz  
21°C

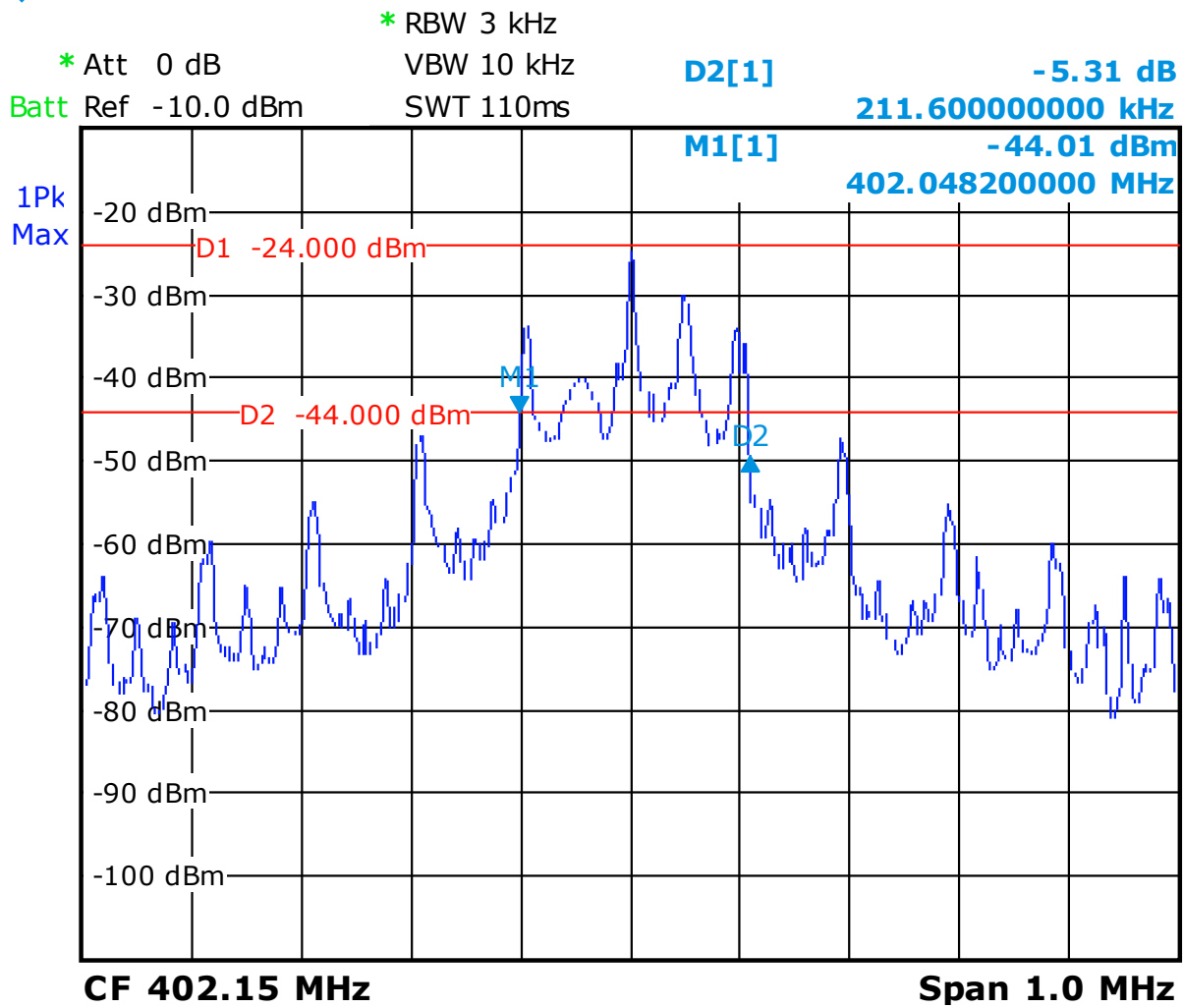



Graphic N°11  
Emission Bandwidth  
230Vdc  
403,65MHz  
21°C

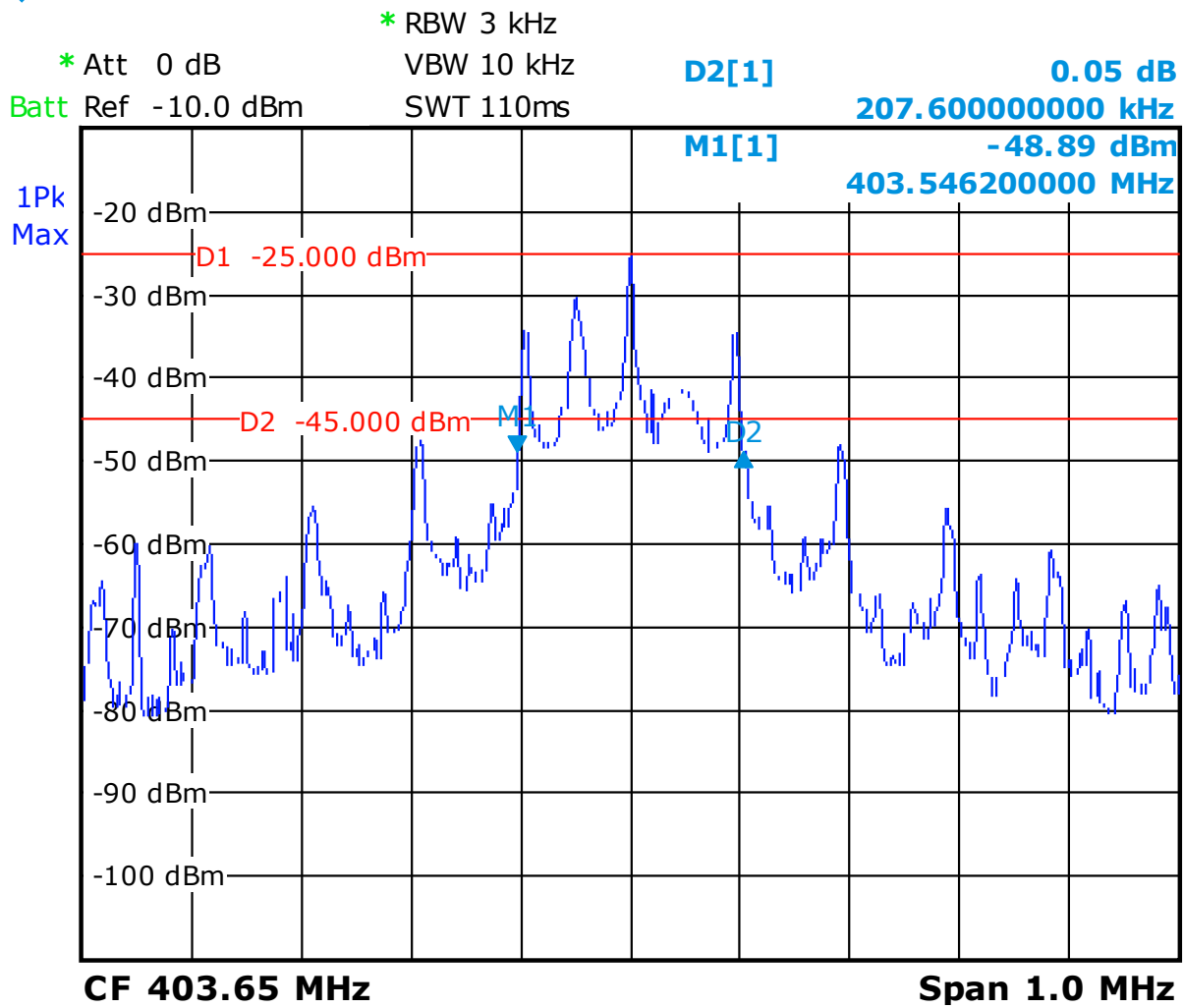



Graphic N°12  
Emission Bandwidth  
230Vdc  
404,85MHz  
21°C

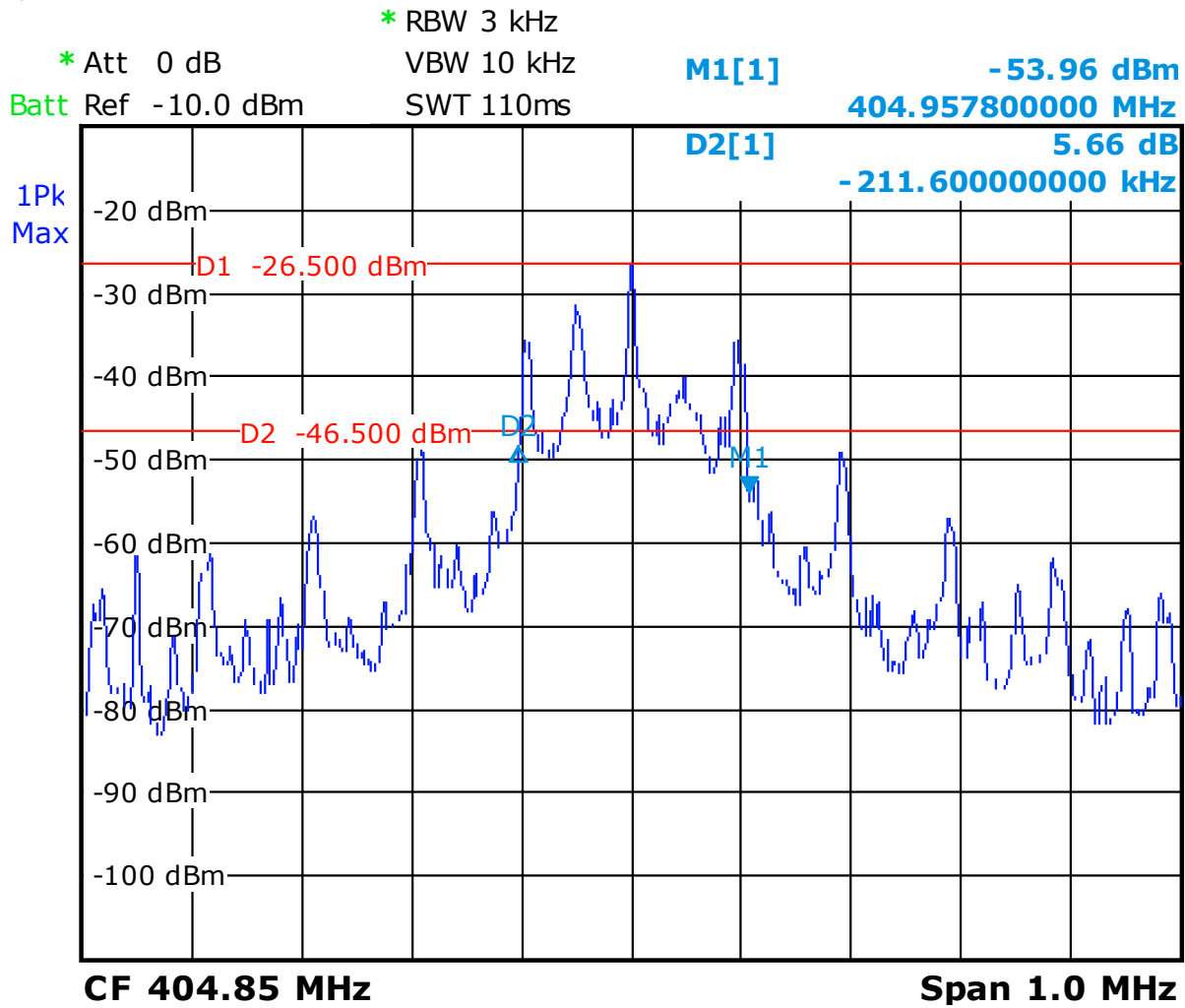



Graphic N°13  
 Unwanted emissions and spurious radiation (402,15MHz + 2412MHz)  
 Vertical + Horizontal Polarization  
 230Vdc  
 21°C

— FCC 15.209 >30M - Classe:1 - QCrête/3.0m/  
 — Channel Low (Horizontal)  
 — Channel Low (Vertical)

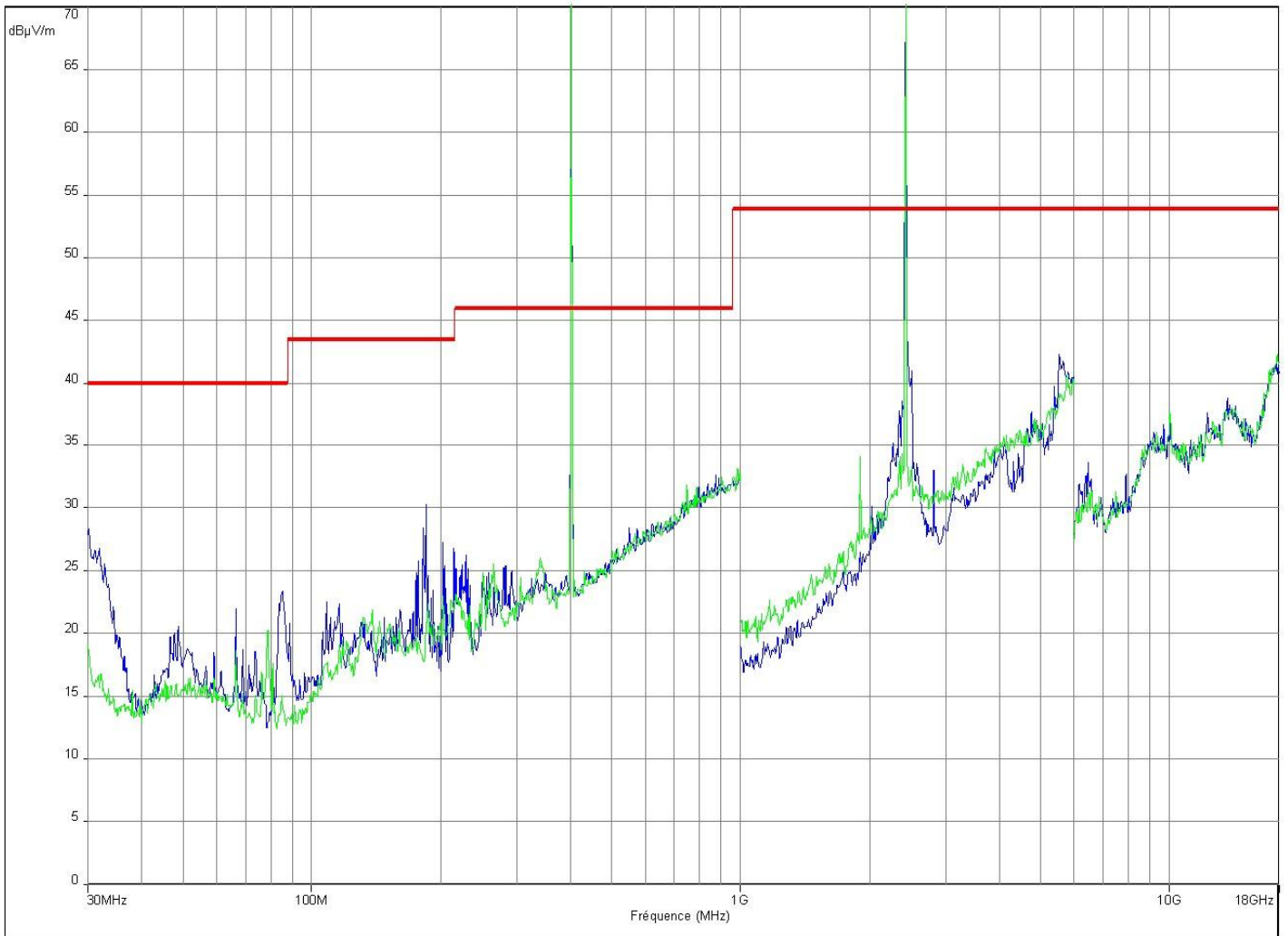

Graphic N°14  
Unwanted emissions and spurious radiation (403,65MHz + 2440MHz)  
Vertical + Horizontal Polarization  
230Vdc  
21°C

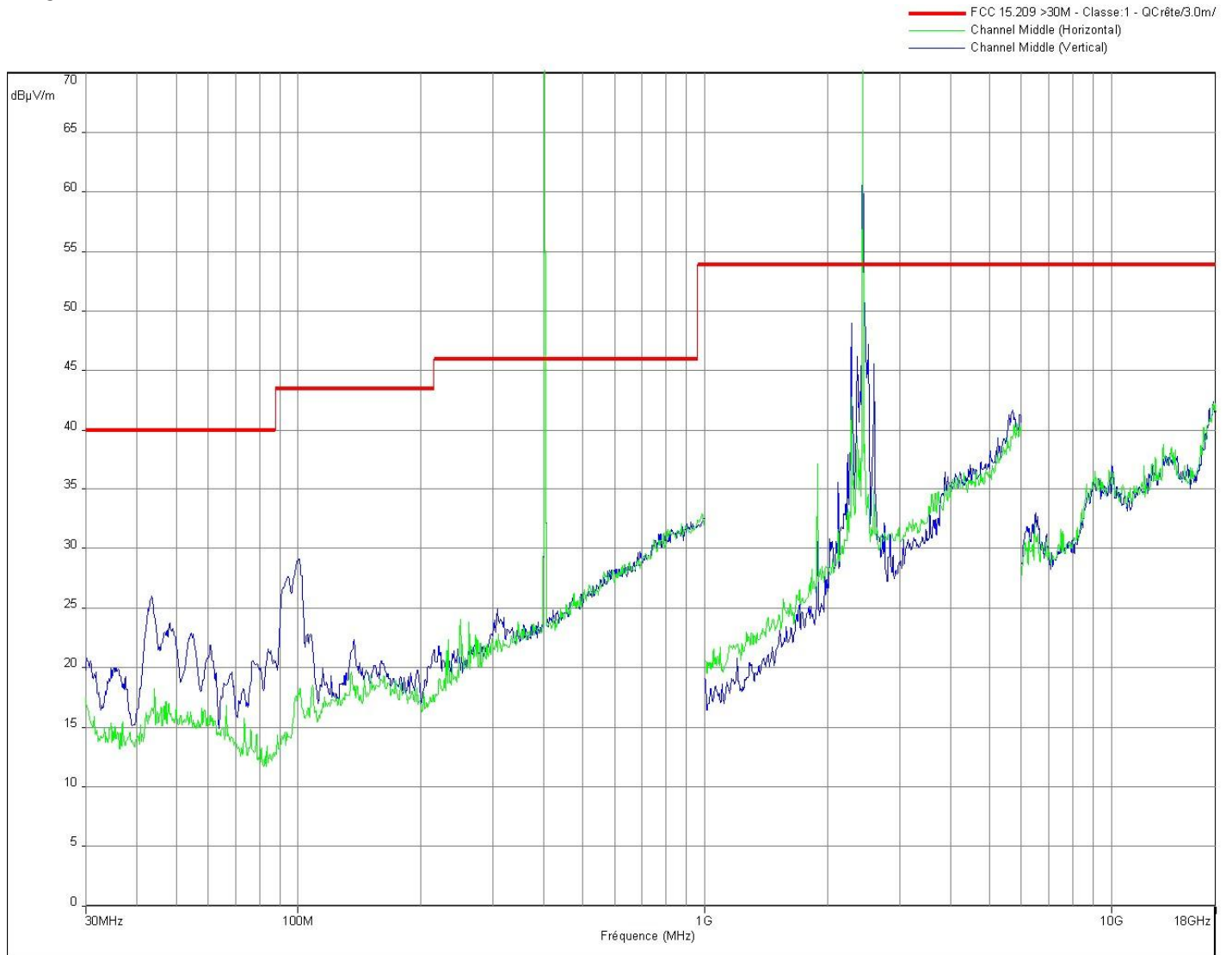

Graphic N°15  
Unwanted emissions and spurious radiation (404,85MHz + 2459MHz)  
Vertical + Horizontal Polarization  
230Vdc  
21°C

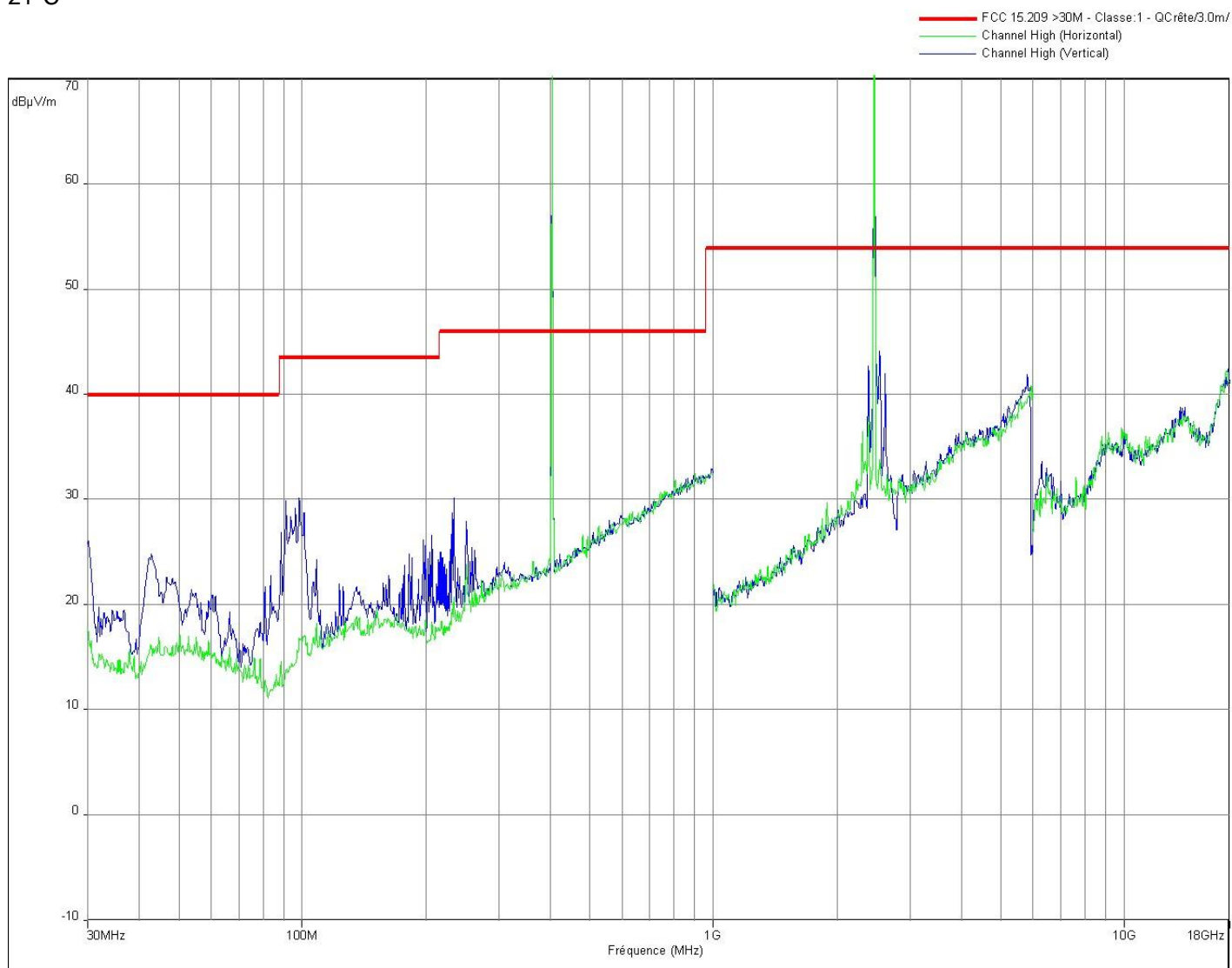



L C I E

TEST REPORT N°106440-611204-E-Cr-2012-01-10

Graphic N°16  
Conducted emission  
Phase line  
110V/60Hz

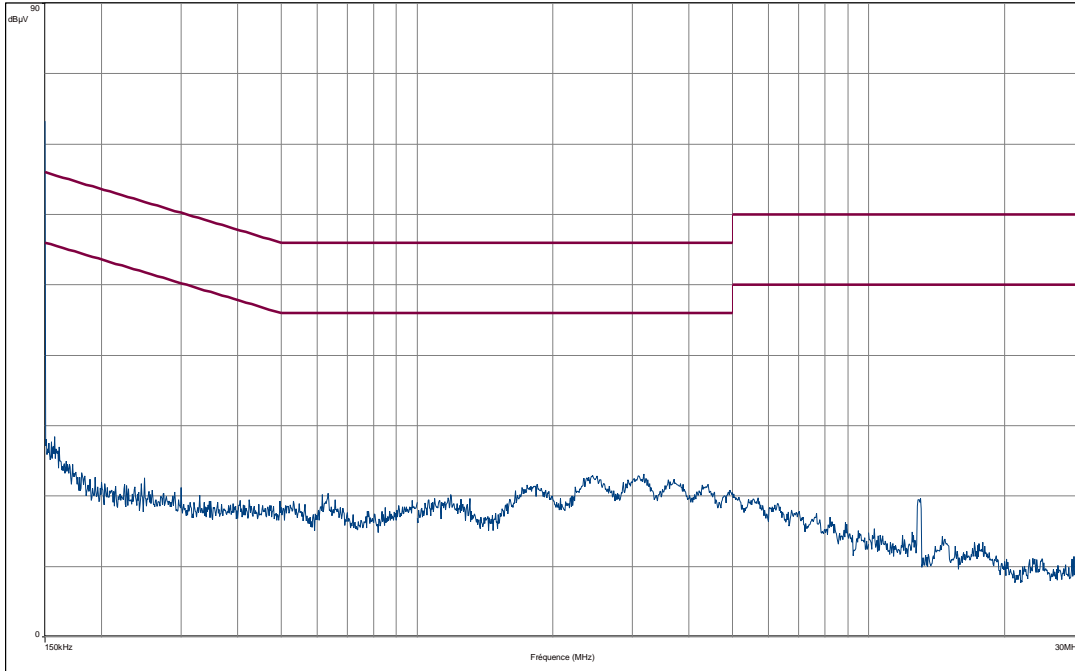

Graphic N°17  
Conducted emission  
Neutral line  
110V/60Hz

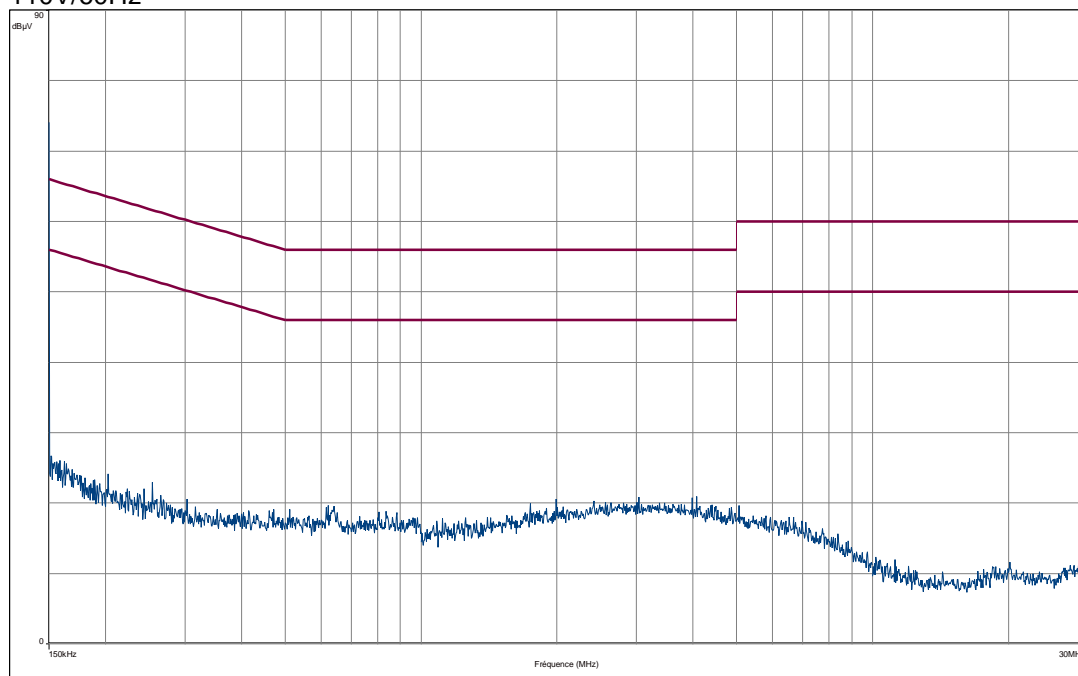



Graphic N°18  
Monitoring System Bandwidth  
230Vdc  
22°C



Offs -29.9 dB      \* RBW 100 kHz  
Att 0 dB            \* VBW 10 kHz      **M1[1]**                      -90.42 dBm  
Batt Ref -49.9 dBm      SWT 10ms                      **403.649700000 MHz**

1Pk  
Clrw

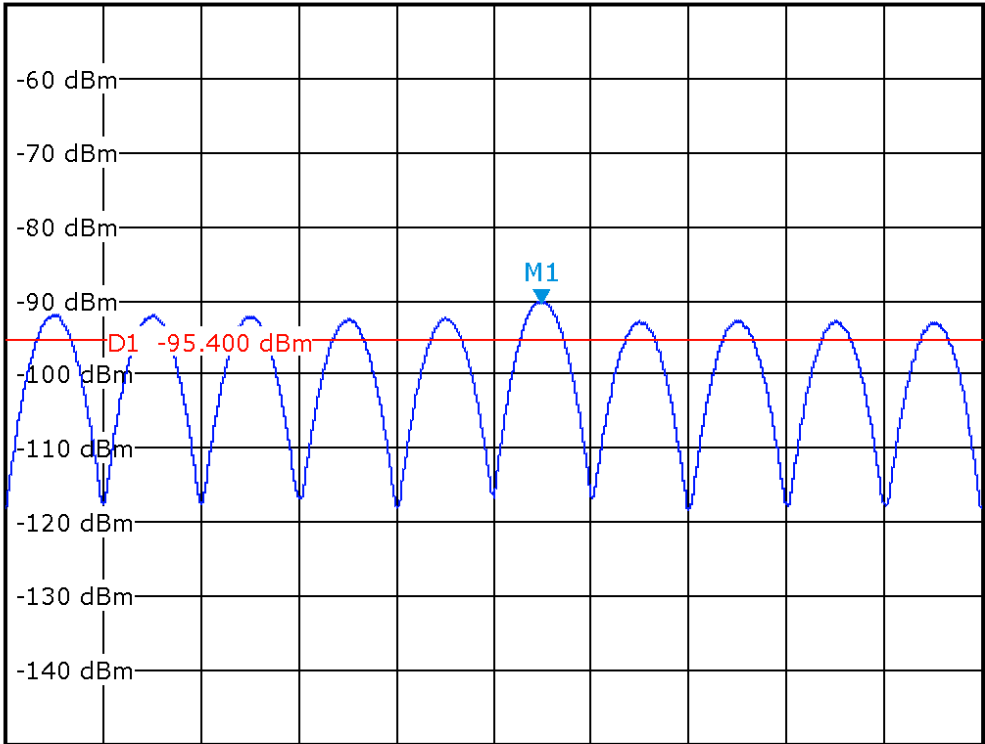

CF 403.5 MHz

Span 3.0 MHz



Graphic N°19  
Monitoring System Bandwidth  
230Vdc  
22°C



Offs -29.9 dB      \* RBW 100 kHz  
Att 0 dB          \* VBW 10 kHz  
Batt Ref -49.9 dBm      SWT 10ms

M1[1]      -90.34 dBm  
403.547900000 MHz

1Pk  
ClrW

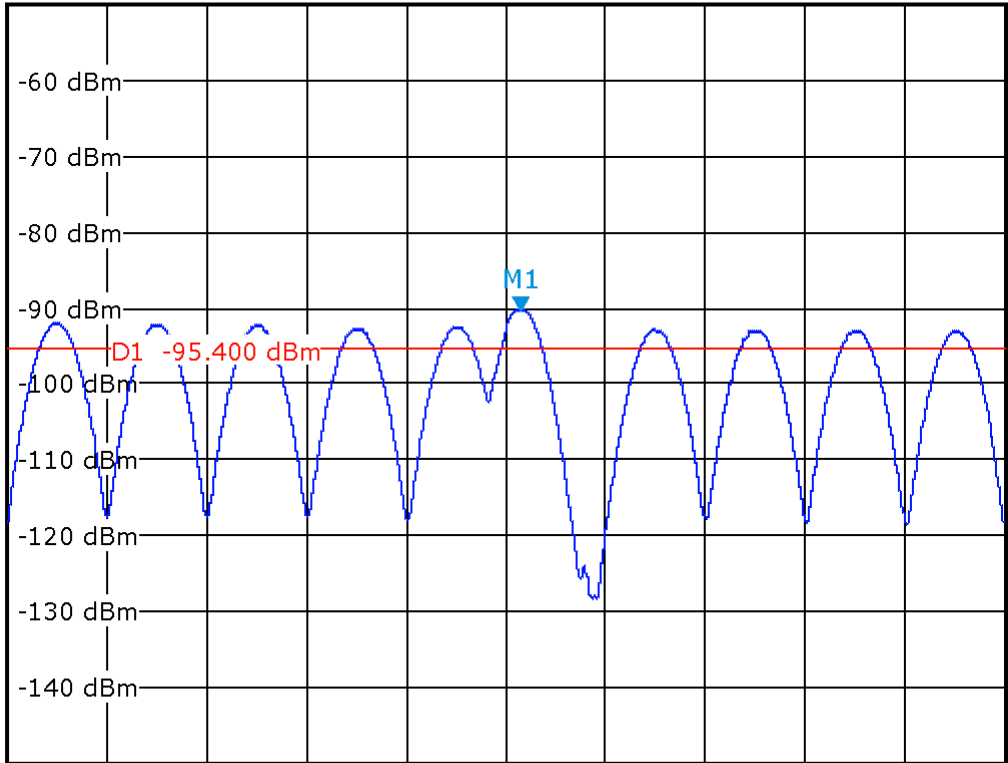

CF 403.5 MHz

Span 3.0 MHz



Graphic N°20  
Monitoring System Bandwidth  
230Vdc  
22°C



Offs -29.9 dB \* RBW 100 kHz  
Att 0 dB \* VBW 10 kHz  
Batt Ref -49.9 dBm SWT 10ms

M1[1] -78.25 dBm  
403.75750000 MHz

1Pk  
Clrw

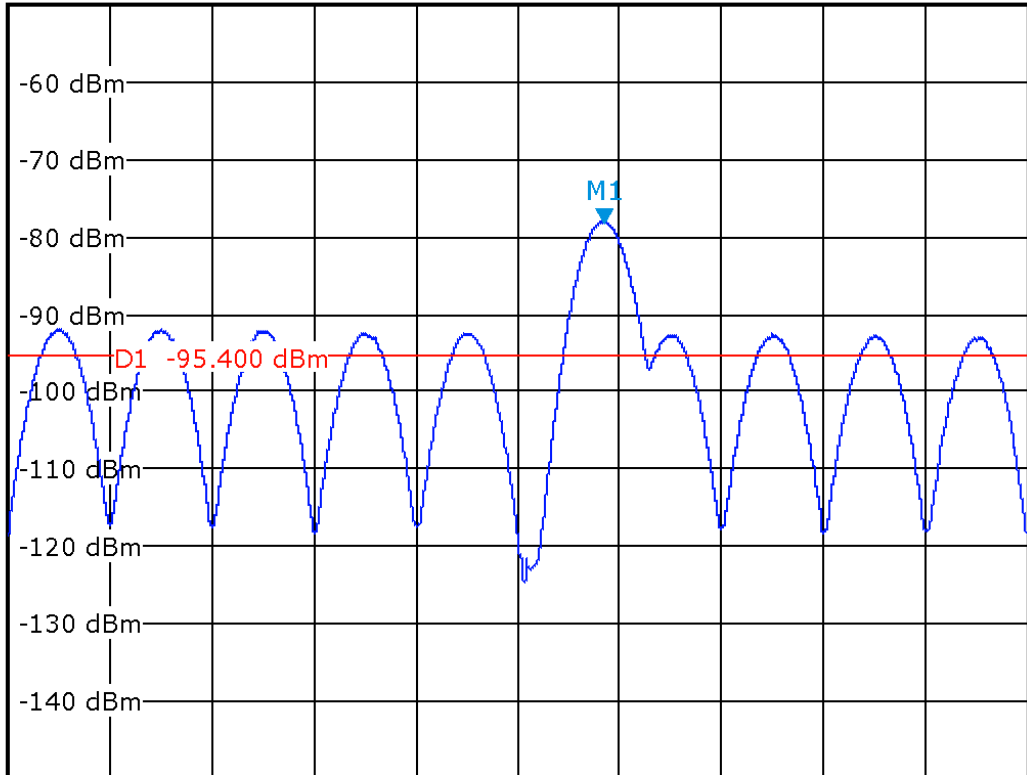

CF 403.5 MHz

Span 3.0 MHz





Graphic N°21  
Scan Cycle Time  
230Vdc  
22°C



Offs -29.9 dB \* RBW 100 kHz  
Att 0 dB \* VBW 300 kHz  
Batt Ref -49.9 dBm \* SWT 5s

D2[1] -11.93 dB

1.189999800 s

M1[1] -83.04 dBm

-29.999800000 ms

1Pk  
Clrw

SGL  
Trg  
Vid

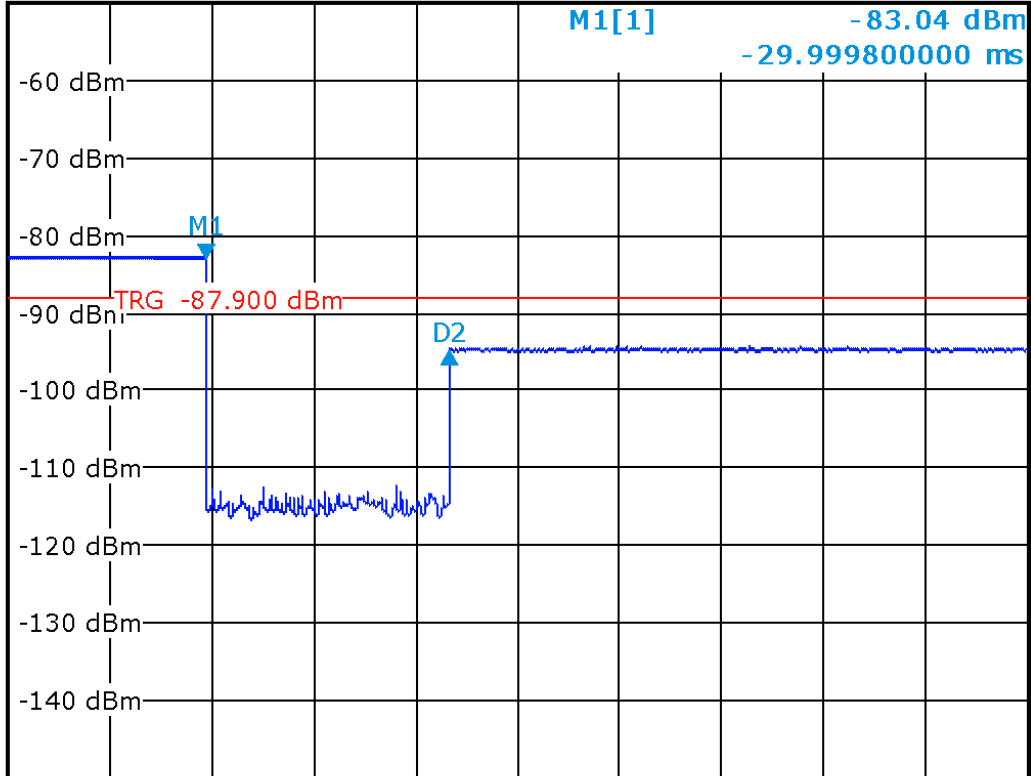

CF 403.65 MHz

500.0 ms/



Graphic N°22  
Minimum Channel Monitoring Period  
230Vdc  
22°C



Offs -20.6 dB \* RBW 100 kHz

Att 0 dB \* VBW 3 kHz

Batt Ref -50.0 dBm

SWT 20ms

M1[1]

-84.08 dBm

402.15870000 MHz

1Pk  
View

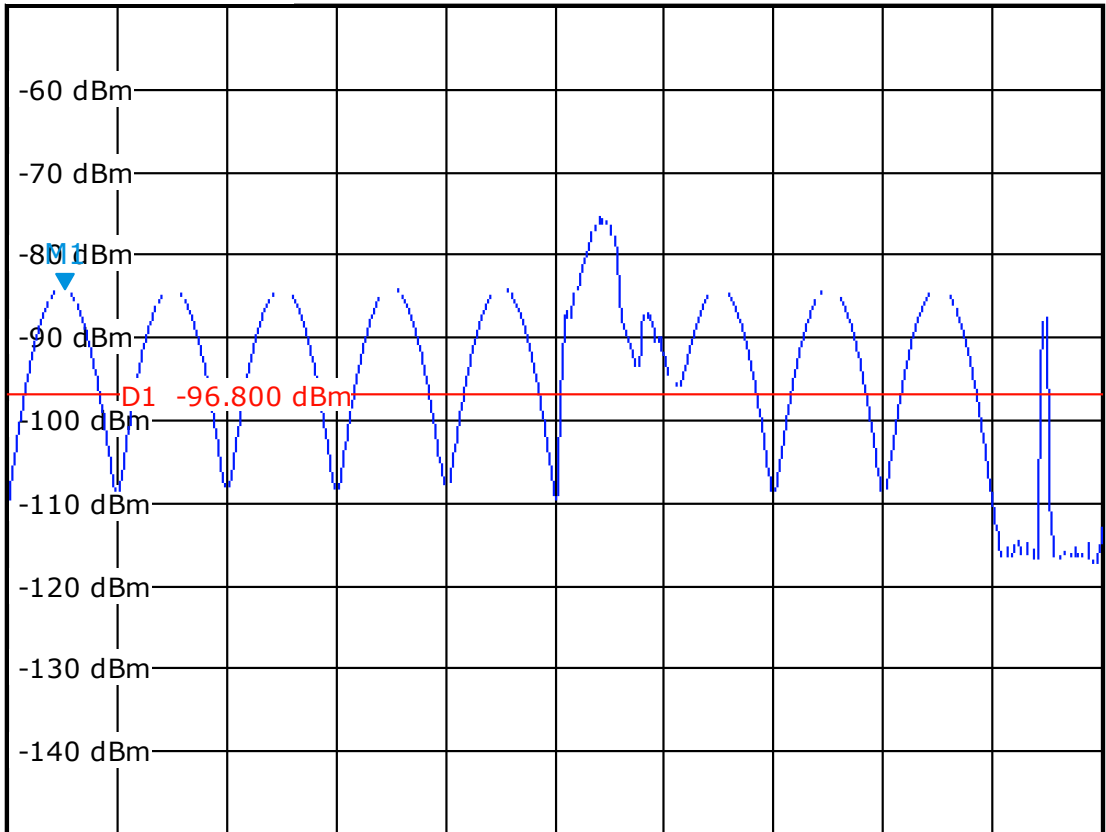

CF 403.5 MHz

Span 3.0 MHz



Graphic N°23  
Channel Access  
230Vdc  
22°C



Offs -29.9 dB \* RBW 100 kHz

Att 0 dB \* VBW 300 kHz

Batt Ref -49.9 dBm \* SWT 50ms

M3[1] -92.15 dBm

402.745508982 MHz

M1[1] -88.96 dBm

403.649700000 MHz

M2[1] -84.95 dBm

403.350299401 MHz

1Pk  
Clrw

SGL

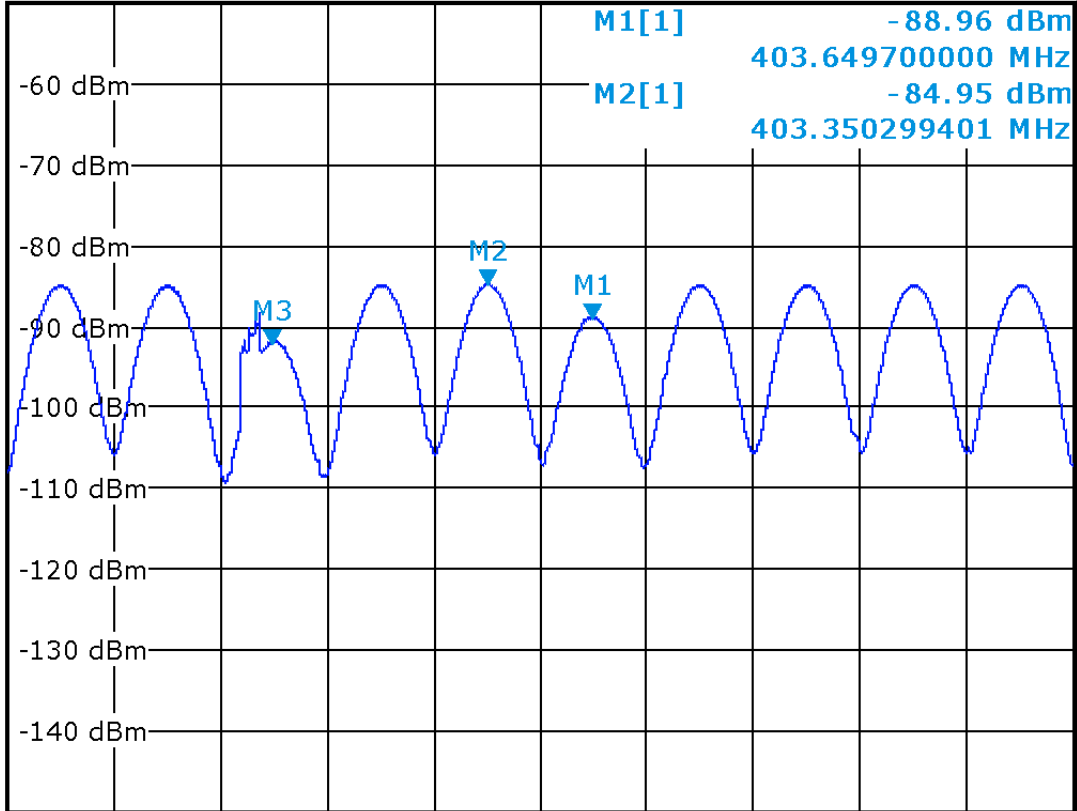

CF 403.5 MHz

Span 3.0 MHz



**19. ANNEX 3 (TEST EQUIPMENT LIST)**

Test	Apparatus	Trade Mark	Type	Registration number
X	Signal generator	HP	8657B	A5442024
X	RF step attenuator 139dB	ROHDE & SCHWARZ	DPSP	A7122105
X	Full anechoic chamber	SIEPEL	S36	D3044019
X	Signal generator	HP	8648B	A5442033
X	Signal generator	HP	8648B	A5442032
X	Signal generator	HP	8648B	A5442031
X	Signal generator	HP	E4433B	A5488014
X	Signal generator	ROHDE & SCHWARZ	SMIQ	A5442039
X	Bilog Antenna	CHASE	CBL 6111C	C2040124
X	Signal generator	HP	8657B	A5442023
X	Double Ridge Guide Horn Antenna	AH SYSTEMS	SAS-S71	C2042041
X	Logperiodic antenna	AMPLIFIER RESEARCH	ATR80M6G	C2040149
X	Preamplifier	BONN Elektronik	BLNA 3018-8F30S	A7080053
X	Climatic Chamber	SECASI Technologies	SLT-34	D1024029
X	Horn antenna	EMCO	.3115	C2042016
X	Signal Generator	ROHDE & SCHWARZ	SMY02	A5442013
X	Signal Generator	HP	8656B	E5400003
X	Bilog antenna	CHASE	CBL 6112A	C2040040
X	Semi anechoic chamber	SIEPEL	C01	D3044008
X	Signal Generator	HP	8657B	A5442019
X	Coupler	Mini circuit	ZB8PD	
X	Receiver	RHODE & SCHWARZ	ESU	A2642018
X	V ISLN	RHODE & SCHWARZ	ESH2-Z5	C2322001
X	RSI	TESEQ	TLISN-T4	C2320097
X	Spectrum analyzer	FSL6	R & S	A4060032
X	EMI Test Receiver	ROHDE & SCHWARZ	ESMI	A2642009
X	Power supply	1501L	CALIFORNIA INSTRUMENT	A7042261

*End of this test report*