



**L C I E**

## TEST REPORT

Number  
Composition of document

## RADIO

112624-622708-F-Cr2012-10-22  
45 pages

### Standards

ETSI EN 301 839-1 V1.2.1  
ETSI EN 301 839-2 V1.3.1  
FCC RULES PART 95I  
FCC RULES PART 15  
FCC RYLES PART 2  
IC RADIO STANDARDS RSS-243  
Specified low-power radio equipment (Item 8 of Article 2 Paragraph 1 of Certification Ordinance)

### Issued to

SORIN CRM  
Parc d'affaires NOVEOS  
4, Avenue Réaumur  
92140 Clamart Cedex , FRANCE

Mme DE JESO

### Apparatus under test

Trade mark  
Manufacturer  
Type  
Serial number

Syndeli RF implantable cardioverter defibrillator  
SORIN Group  
SORIN BIOMEDICA CRM  
PARADYM RF — CRT-D model 9750  
148YY028

### Test date

2012/03/20 and 2012/03/26 to 2012/03/30

### Tests performed by

Stéphane PHOUDIAH & Laurent DENEUX

### Test site

Fontenay Aux Roses & Ecuelles

### File issued on

2012/10/22

### File corrected on

2012/10/22

### File initially issued on

2012/04/18

Written by :  
**Stéphane PHOUDIAH & Laurent DENEUX**  
Tests operator

Approved by :  
**Marc CANCOUET**  
Technical manager

This document shall not be reproduced, except in full, without the written approval of the LCIE. This document contains results related only to the item tested. It does not imply the conformity of the whole production to the items tested. Unless otherwise specified, the decision of conformity takes into account the uncertainty of measures.

LCIE  
Laboratoire Central  
des Industries Electriques  
Une société de Bureau Veritas

33, av du Général Leclerc  
BP 8  
92266 Fontenay-aux-Roses cedex  
France

Tel : +33 1 40 95 60 60  
Fax : +33 1 40 95 86 56  
contact@lcie.fr  
www.lcie.fr

Société par Actions Simplifiée  
au capital de 15 745 984 €  
RCS Nanterre B 408 363 174



**SUMMARY**

|     |   |    |
|-----|---|----|
| 1.  | TEST PROGRAM .....  | 3  |
| 2.  | EQUIPMENT DESCRIPTION.....  | 5  |
| 3.  | FREQUENCY ERROR & FREQUENCY STABILITY.....  | 8  |
| 4.  | EFFECTIVE RADIATED POWER, MAXIMUM TRANSMITTER POWER & ANTENNA POWER .....         | 9  |
| 5.  | EMISSION BANDWIDTH & OCCUPIED BANDWIDTH.....                                      | 10 |
| 6.  | SPURIOUS EMISSIONS OF TRANSMITTER & TOLERANCE OF UNWANTED EMISSION INTENSITY..... | 11 |
| 7.  | UNWANTED RADIATION .....  | 14 |
| 8.  | RECEIVER SPURIOUS RADIATION & SECONDARY RADIATED EMISSION .....                   | 17 |
| 9.  | RADIATION EMISSIONS.....  | 20 |
| 10. | TEST EQUIPMENT LIST .....   | 22 |
| 11. | UNCERTAINTIES CHART .....   | 23 |
| 12. | ANNEX 1 (GRAPHS) .....  | 24 |
| 13. | ANNEX 2 (FLUID DATA SHEET MSL 450).....   | 43 |



**1. TEST PROGRAM**

• **References**

Standards : ETSI EN 301 839-1 V1.3.1  
 ETSI EN 301 839-2 V1.2.1  
 ERC Recommendation 70-03  
 FCC RULES PART 95I  
 FCC RULES PART 15  
 FCC RULES PART 2  
 IC RADIO STANDARDS RSS-243  
 Specified low-power radio equipment (Item 8 of Article 2 Paragraph 1 of Certification Ordinance)

• **Transmitter requirement:**

| Clause (ETSI EN 301 839-1)<br>Clause (FCC PART 95I)<br>Clause (RSS 243)<br>Clause (Specified low-power radio equipment (Item 8 of Article 2 Paragraph 1 of Certification Ordinance))<br>Test Description   | TEST RESULT - Comments  |
|--|---|
| EN § 8.1 – Frequency error<br>FCC § 95.627 (e) – Frequency stability<br>FCC § 2.1055 – Measurements required: Frequency stability<br>RSS § 3.3 – Frequency stability<br>Specified low-power radio equipment (Item 8 of Article 2 Paragraph 1 of Certification Ordinance) –Tolerance of frequency                                     | PASS<br>PASS<br>PASS<br>PASS<br>PASS  |
| EN § 8.3 – Effective radiated power of the fundamental emission<br>FCC § 95.639 (f) – Maximum transmitter power<br>FCC § 2.1046 – Measurements required: RF power output<br>RSS § 5.4 – Maximum transmitter power<br>Specified low-power radio equipment (Item 8 of Article 2 Paragraph 1 of Certification Ordinance) – Antenna gain | PASS<br>PASS<br>PASS<br>PASS<br>PASS  |
| EN § 8.2 – Emission bandwidth<br>FCC § 95.633 (e) – Emission bandwidth<br>FCC § 2.1049 – Measurements required: Occupied bandwidth<br>RSS § 3.2 – Occupied bandwidth<br>Specified low-power radio equipment (Item 8 of Article 2 Paragraph 1 of Certification Ordinance) – Tolerance of occupied bandwidth                           | PASS<br>PASS<br>PASS<br>PASS<br>PASS  |
| EN § 8.5 – Frequency stability under low voltage conditions  | N/A (EUT hermetically sealed: See last paragraph in clause 5.2.2 of ETSI EN 301 839-1 V1.3.1) |
| EN § 8.4 – Spurious emissions of transmitter<br>Specified low-power radio equipment (Item 8 of Article 2 Paragraph 1 of Certification Ordinance) – Tolerance of unwanted emission intensity  | PASS<br>PASS  |
| FCC § 95.635 (d) – Unwanted radiation<br>FCC § 2.1053 – Measurements required: Field strength of spurious radiation<br>RSS § 3.4 – Unwanted radiation<br>Specified low-power radio equipment (Item 8 of Article 2 Paragraph 1 of Certification Ordinance) – Limit of secondary radiated emission                                     | PASS<br>PASS<br>PASS<br>PASS  |
| 15.207 – Conducted emission  | N/A (Equipment powered by battery)  |
| FCC § 2.1047 – Measurements required: Modulation characteristics   | PASS ( please refer to §2.1 Equipment information p.5)  |
| FCC § 2.1057 – Frequency spectrum to be investigated   | PASS (see §2.1 Equipment information p.5)   |



• **Receiver requirement:**

| <b>Clause (ETSI EN 301 839-1)</b><br><b>Clause (FCC PART 15) (only for 400MHz receiver)</b><br><b>Clause (FCC PART 95I)</b><br><b>Clause (RSS 243-243)</b><br><b>Test Description</b>  | <b>TEST RESULT -</b><br><b>Comments</b> |
|--|---|
| <b>EN § 9.1</b> – Spurious radiation of receivers<br><b>FCC § 2.1053</b> – Measurements required: Field strength of spurious radiation   | PASS<br>PASS                            |
| <b>FCC § 15.109</b> – Radiated emissions<br><b>RSS § 3.5</b> – Radiated emissions  | PASS<br>PASS                            |
| <b>EN § 10.1</b> – Monitoring system threshold power level<br><b>FCC § 95.627 (a)(3)</b> – Monitoring system threshold power level<br><b>RSS § 5.7.1</b> – Monitoring system threshold power level   | N/A<br>N/A<br>N/A                       |
| <b>EN § 10.2</b> – Monitoring system bandwidth<br><b>FCC § 95.627 (a)(1)</b> – Monitoring system bandwidth<br><b>RSS § 5.7.2</b> – Monitoring system bandwidth   | N/A<br>N/A<br>N/A                       |
| <b>EN § 10.3.1.1 &amp; 10.3.3.1</b> – Scan cycle time<br><b>FCC § 95.627 (a)(2)</b> – Scan cycle time<br><b>RSS § 5.7.3</b> – Scan cycle time  | N/A<br>N/A<br>N/A                       |
| <b>EN § 10.3.1.2 &amp; 10.3.3.2</b> – Minimum channel monitoring period<br><b>FCC § 95.627 (a)(2)</b> – Minimum channel monitoring period<br><b>RSS § 5.7.4</b> – Minimum channel monitoring period  | N/A<br>N/A<br>N/A                       |
| <b>EN § 10.4</b> – Channel access<br><b>FCC § 95.627 (a)(4)</b> – Channel access<br><b>RSS § 5.7.5</b> – Channel access  | N/A<br>N/A<br>N/A                       |
| <b>EN § 10.5</b> – Discontinuation of MICS session<br><b>95.627 (a)(4)</b> – Discontinuation of MICS session<br><b>RSS § 5.7.6</b> – Discontinuation of MICS session<br><b>Specified low-power radio equipment (Item 8 of Article 2 Paragraph 1 of Certification Ordinance)</b> – Transmission suspension function due to interruption of communications | N/A<br>N/A<br>N/A<br>N/A                |
| <b>EN § 10.6</b> – Use of pre-scanned alternate channel<br><b>FCC § 95.627 (a)(5)</b> – Use of pre-scanned alternate channel<br><b>RSS § 5.7.7</b> – Use of pre-scanned alternate channel  | N/A<br>N/A<br>N/A                       |

PASS: EUT complies with standard's requirement  
 FAIL: EUT does not comply with standard's requirement  
 N/A: Not Applicable  
 N/P: Test Not Performed

**Remark:** The equipment is: - transmitter and receiver at 400MHz  
 - only receiver at 2400 MHz.

## 2. EQUIPMENT DESCRIPTION

### 2.1. HARDWARE IDENTIFICATION

- **Equipment under test (EUT):**



The EUT is housed in a single cabinet that cannot be readily opened because the enclosure is hermetically sealed.

- **Auxiliary equipment used for testing:**

- Human torso simulator
- Fluid corresponding to human tissue characteristics at that frequency.
- Lead IS-1 LV
- Lead IS-1 A
- Lead IS-1 RV
- Lead DF-1 SVC
- Lead DF-1 RV

- **Equipment information:**

- External antenna connector: No
- Frequency band allocated: 402MHz to 405MHz
- Frequency used for test:
  - Fmin: 402,15MHz
  - Fnom: 403,65MHz
  - Fmax: 404,85MHz
- Modulation: 2 FSK
- Data rate: 200kb/s
- Number of channel: 10
- Antenna type: Integral
- Equipment intended for use as a mobile station
- Equipment designed for continuous operation
- Stand By mode: No
- Extreme temperature range:
  - Tmin: 25°C
  - Tnom: 37°C
  - Tmax: 45°C
- Extreme test source voltage: -Vnom: BOL: 3.25 V. ERI: 2.66 V. EOL: 2.5 V (Internal Battery)

## 2.2. RUNNING MODE

The EUT is set in the following modes during tests:

- Permanent emission with modulation
- Permanent emission without modulation
- Permanent reception

## 2.3. EQUIPEMENT SET UP AND TESTING CONFIGURATION

Equipment (ULP-AMIs) intended to be implanted in a human body shall be tested in a simulated man constructed as follows in order to simulate operation of the ULP-AMI under actual operation conditions as shown in figure A.2 of EN 301 489-1.

An appropriate simulator for testing ULP-AMI consists of a cylindrical acrylic container with an outside diameter of 300 mm, a sidewall thickness of 6 mm, and a fluid-filled height of 760 mm. It shall be filled with a material that is sufficiently fluid that it will flow around the AIMD without any voids. The dielectric and conductivity properties of this material shall match the dielectric and conductivity properties of human muscle tissue at 403,5 MHz (conductivity = 0,93 and relative permittivity = 57,2). Simple saline solutions do not meet the dielectric and conductivity requirements for use as a substitute for human tissue. All emissions measurements will be made using the above specification with the tissue substitute material at a nominal temperature between 22 °C and 38 °C.

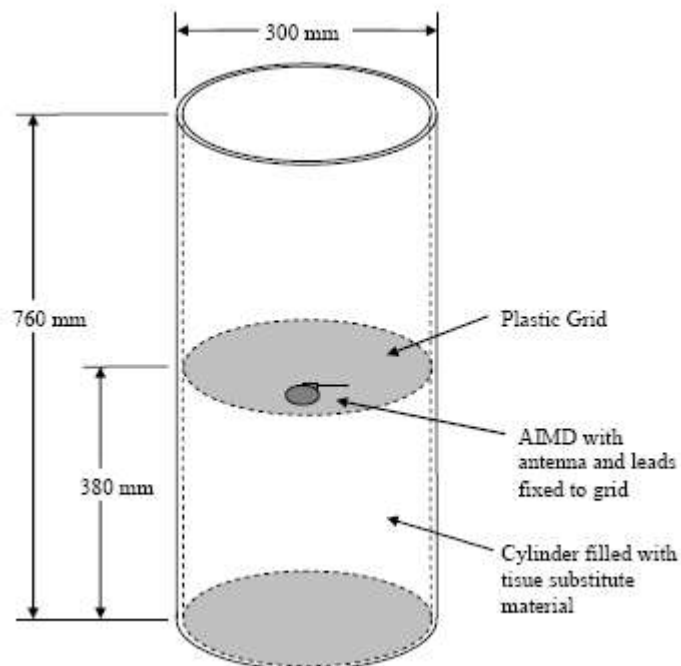

For the testing, the equipment under test (EUT) was suspended in a Plexiglas torso simulator as specified above. The simulator used was constructed in accordance with FCC 95.627(g)(3)(i), EN 301 839-1 (A.113) and EN 301 489-27 annex B.

During the test, the EUT was centred vertically in Plexiglas cylinder. The torso simulator was filled with a fluid formulated in accordance with the specification by using tissue material corresponding to human tissue characteristics at that frequency. The fluid temperature was maintained between 20° to 25° C. There are also the reference for simulator fluid (see annex 2).

#### 2.4. EQUIPEMENT LABELLING



#### 2.5. EQUIPMENT MODIFICATIONS

No equipment modification has been necessary during testing.



### 3. FREQUENCY ERROR & FREQUENCY STABILITY

#### 3.1. TEST CONDITIONS

Test performed by : Stéphane PHOUDIAH  
Date of test : 2012/03/27  
Ambient temperature : 24°C  
Relative humidity : 32%

#### 3.2. TEST SETUP

FCC 95.627(e)  
RSS 243 §3.3  
ETSI EN 301 839-1 §8.1  
Specified low-power radio equipment (Item 8 of Article 2 Paragraph 1 of Certification Ordinance)

The test is performed on EUT in permanent emission without modulation mode.  
For measurement under normal and extreme test conditions, the Equipment Under Test is installed in the climatic chamber. A test fixture is created to perform the measurement.

#### 3.3. RESULTS

Frequency: Fmin

| Temperature                | Tmin        | Tnom       | Tmax       |
|----------------------------|-------------|------------|------------|
| <b>Power voltage: Vnom</b> |             |            |            |
| Frequency (MHz)            | 402,1498    | 402,1512   | 402,1522   |
| Frequency Drift (ppm)      | -0,49732687 | 2,98396121 | 5,47059555 |

Frequency: Fnom

| Temperature                | Tmin       | Tnom       | Tmax   |
|----------------------------|------------|------------|--------|
| <b>Power voltage: Vnom</b> |            |            |        |
| Frequency (MHz)            | 403,65399  | 403,6536   | 403,65 |
| Frequency Drift (ppm)      | 9,88480119 | 8,91861761 | 0      |

Frequency: Fmax

| Temperature                | Tmin       | Tnom       | Tmax       |
|----------------------------|------------|------------|------------|
| <b>Power voltage: Vnom</b> |            |            |            |
| Frequency (MHz)            | 404,85399  | 404,8516   | 404,8538   |
| Frequency Drift (ppm)      | 9,85550204 | 3,95208102 | 9,38619242 |

See graphics in annex 1

Result: **PASS**

Limit: → ± 100 ppm



**4. EFFECTIVE RADIATED POWER, MAXIMUM TRANSMITTER POWER & ANTENNA POWER****4.1. TEST CONDITIONS**

Test performed by : Stéphane PHOUDIAH  
Date of test : 2012/03/26  
Ambient temperature : 24°C  
Relative humidity : 28%

**4.2. TEST SETUP**

FCC 95.639(f)  
RSS 243 §5.4  
ETSI EN 301 839-1 §8.3  
Specified low-power radio equipment (Item 8 of Article 2 Paragraph 1 of Certification Ordinance)

The test is performed on EUT in permanent emission without modulation mode on vertically and horizontally position. The setup is 1.5m above the ground reference plane on a wooden table. Distance between measuring antenna and the EUT is 3 meters. The measuring antenna is in vertical and then in horizontal polarization. Measurement bandwidth was 100kHz. Continuous linear turntable azimuth search was performed with 360 degrees range.

The substitution method is used to obtain the effective isotropic radiated power and effective radiated power. (KDB 412172 D01 Determining ERP and EIRP)

**4.3. RESULTS**

Maximum values for both polarizations:

| Frequency (MHz) | Generator (dBm) | Cables loss (dB) | Antenna Gain (dBi) | EIRP (dBm) | EIRP (µW) | ERP (dBm) | ERP (µW) |
|-----------------|-----------------|------------------|--------------------|------------|-----------|-----------|----------|
| Fmin            | -35,5           | 1,6              | 6,6                | -40,5      | 0,089     | -42,64    | 0,054    |
| Fnom            | -35,3           | 1,7              | 6,6                | -40,2      | 0,095     | -42,34    | 0,058    |
| Fmax            | -37,2           | 1,8              | 6,6                | -42        | 0,063     | -44,14    | 0,038    |

Result: **PASS**

Limit: → 25µW or -16dBm

**5. EMISSION BANDWIDTH & OCCUPIED BANDWIDTH****5.1. TEST CONDITIONS**

Test performed by : Stéphane PHOUDIAH  
Date of test : 2012/03/28  
Ambient temperature : 25°C  
Relative humidity : 30%

**5.2. TEST SETUP**

FCC 95.633(e)  
RSS 243 §3.2  
ETSI EN 301 839-1 §8.2  
Specified low-power radio equipment (Item 8 of Article 2 Paragraph 1 of Certification Ordinance)

The test is performed on EUT in permanent emission with modulation. the Equipment Under Test is installed in the climatic chamber. A test fixture is created to perform the measurement. RBW was 3kHz and VBW was 10kHz. The Emission Bandwidth is measured 20dB below the peak power.

**5.3. RESULTS**

| Frequency (MHz) | Emission Bandwidth (kHz) | Occupied Bandwidth (kHz) |
|-----------------|--------------------------|--------------------------|
| Fmin            | 206,9                    | 219,88                   |
| Fnom            | 208,6                    | 213,41                   |
| Fmax            | 208,6                    | 206,95                   |

See graphics in annex 1

Result: **PASS**

Limit: → Shall not exceed 300kHz

**6. SPURIOUS EMISSIONS OF TRANSMITTER & TOLERANCE OF UNWANTED EMISSION INTENSITY****6.1. TEST CONDITIONS**

Test performed by : Stéphane PHOUDIAH  
Date of test : 2012/03/26  
Ambient temperature : 23°C  
Relative humidity : 30%

**6.2. TEST SETUP**

ETSI EN 301 839-1 §8.2

Specified low-power radio equipment (Item 8 of Article 2 Paragraph 1 of Certification Ordinance)

The test is performed on EUT in permanent emission with modulation mode.

- **Method of measurement**

- Effective Radiated Power, cabinet radiation
- Effective Radiated Power, cabinet and antenna radiation

- **Qualification measurements on an open test site (25MHz to 200MHz):**

The setup is 1.5m above the ground reference plane.

Distance between measuring antenna and the EUT is 10meters for frequency 30MHz to 200MHz.

Test is performed in horizontal (H) and vertical (V) polarization with a bilog antenna below 1GHz and with a horn antenna above 1GHz. Measurement bandwidth was 100kHz. Continuous linear turntable azimuth search was performed with 360 degrees range. Vertical search was performed between 1m and 4m with the measuring antenna.

The Substitution Method is applied on the maximum values observed during the azimuth and vertical search in order to obtain the spurious radiated emission.

- **Qualification measurements in full anechoic chamber (200MHz to 4GHz):**

The setup is 1.5m above the ground reference plane.

Distance between measuring antenna and the EUT is 3meters for frequency 200MHz to 4GHz.

Test is performed in horizontal (H) and vertical (V) polarization with a bilog antenna below 1GHz and with a horn antenna above 1GHz. Measurement bandwidth was 100kHz for measurement below 1GHz and 1MHz for measurement above 1GHz. Continuous linear turntable azimuth search was performed with 360 degrees range.

The Normalized Site Attenuation (NSA) is added to the maximum values observed during the azimuth search in order to obtain the spurious radiated emission.

**6.3. RESULTS**

- **Characterization on open test site (25MHz to 200MHz):**

Vertical antenna

| Operating       |                     |             |
|-----------------|---------------------|-------------|
| Frequency (MHz) | Measure E.R.P (dBm) | Limit (dBm) |
| 32.2            | -62                 | -36         |
| 33.3            | -62                 | -36         |
| 34.5            | -65                 | -36         |
| 35.3            | -66                 | -36         |
| 36.1            | -65                 | -36         |
| 37.4            | -67                 | -36         |
| 39              | -66                 | -36         |
| 40              | -65                 | -36         |
| 41.3            | -70                 | -36         |
| 44.7            | -64                 | -36         |
| 48              | -62                 | -54         |
| 49.9            | -68                 | -54         |
| 52.9            | -67                 | -54         |
| 60              | -62                 | -54         |
| 64              | -65                 | -54         |
| 67.1            | -67                 | -54         |
| 72              | -64                 | -54         |
| 77.1            | -68                 | -36         |
| 80              | -65                 | -36         |
| 116             | -64                 | -54         |
| 120             | -64                 | -36         |
| 144.4           | -66                 | -36         |
| 156.4           | -67                 | -36         |
| 166.6           | -69                 | -36         |
| 175.9           | -65                 | -54         |
| 199.8           | -65                 | -54         |



Horizontal antenna

| Operating       |                     |             |
|-----------------|---------------------|-------------|
| Frequency (MHz) | Measure E.R.P (dBm) | Limit (dBm) |
| 32.9            | -62                 | -36         |
| 40              | -65                 | -36         |
| 50.3            | -68                 | -54         |
| 59.3            | -69                 | -54         |
| 67.1            | -65                 | -54         |
| 74.5            | -69                 | -36         |
| 133             | -66                 | -36         |
| 144             | -67                 | -36         |
| 166             | -69                 | -36         |
| 200.3           | -68                 | -54         |

- **Characterization in full anechoic chamber (200MHz to 4GHz):**

| Operating       |                     |                       |
|-----------------|---------------------|-----------------------|
| Frequency (MHz) | Measure E.R.P (dBm) | Measure E.I.R.P (dBm) |
| 794,8           | -71,63              | -69,63                |
| 3771,7          | -47,75              | -45,75                |

**Result: PASS**

ETSI EN 301 839-1 §8.2

**Limit:** → 25MHz to 47MHz: -36dBm (operating)/ -57dBm (Standby)  
47MHz to 74MHz: -54dBm (operating)/ -57dBm (Standby)  
74MHz to 87,5MHz: -36dBm (operating)/ -57dBm (Standby)  
87,5MHz to 118MHz: -54dBm (operating)/ -57dBm (Standby)  
118MHz to 174MHz: -36dBm (operating)/ -57dBm (Standby)  
174MHz to 230MHz: -54dBm (operating)/ -57dBm (Standby)  
230MHz to 470MHz: -36dBm (operating)/ -57dBm (Standby)  
470MHz to 862MHz: -54dBm (operating)/ -57dBm (Standby)  
862MHz to 1GHz: -36dBm (operating)/ -57dBm (Standby)  
1GHz to 4GHz: -30dBm (operating)/ -47dBm (Standby)

Specified low-power radio equipment (Item 8 of Article 2 Paragraph 1 of Certification Ordinance)

**Limit:** → -36dBm (operating)

**See graphics in annex 1**



## 7. UNWANTED RADIATION

### 7.1. TEST CONDITIONS

Test performed by : Laurent DENEUX  
Date of test : 2012/03/20  
Ambient temperature : 21°C  
Relative humidity : 48%

### 7.2. TEST SETUP

FCC 95.635(d)  
RSS 243 §3.4

The test is performed on EUT in permanent emission with modulation mode.

- **Method of measurement**

- Effective Radiated Power, cabinet radiation
- Effective Radiated Power, cabinet and antenna radiation

The setup is 1.5m above the ground reference plane.

Distance between measuring antenna and the EUT is 10 meters for frequency 30MHz to 25GHz.

Test is performed in horizontal (H) and vertical (V) polarization with a bilog antenna below 1GHz and with a horn antenna above 1GHz . Measurement bandwidth was 100kHz and 1MHz for measurement above 1GHz. Continuous linear turntable azimuth search was performed with 360 degrees range. Vertical and horizontal search was performed between 1m and 4m with the measuring antenna.



### 7.3. RESULTS

#### Out-Of-Band Emissions

- Characterization on open test site (30MHz to 25GHz):

Fcc Part.15 CLASS B

SORIN  
IMPLANT  
MODEL : PARADYM RF CRT D 9750  
400 Tx

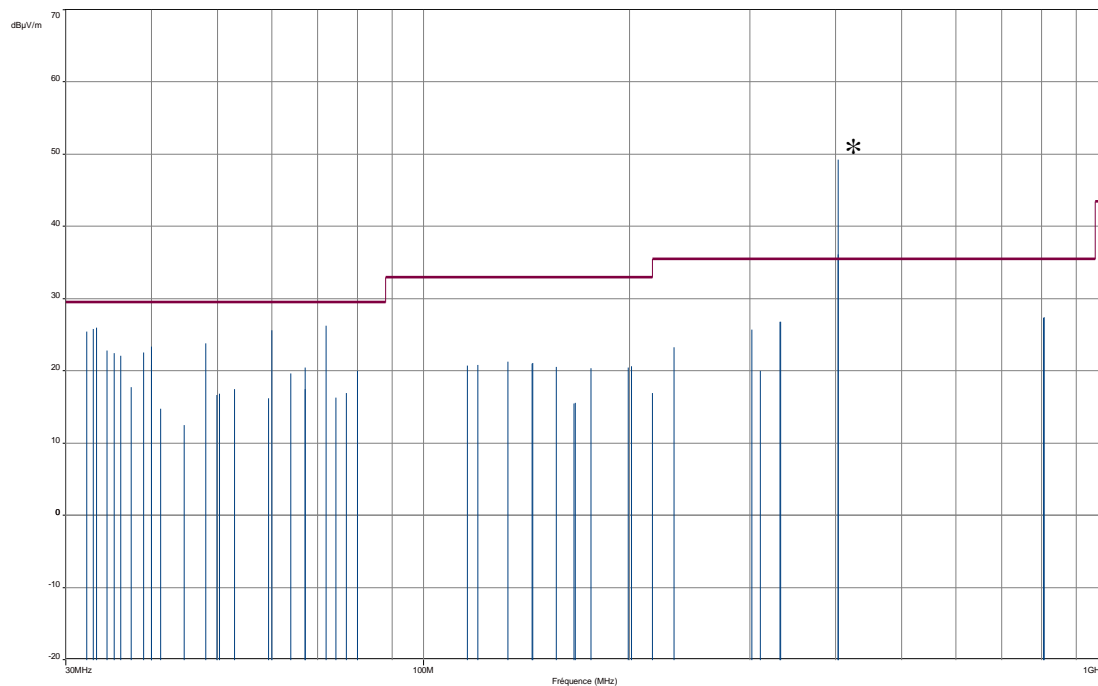

— Limit level

\* Transmitter frequency

**Remark:** During the Scan, no unwanted emission has been detected in the frequency range 1 GHz to 25 GHz.

**Result:** **PASS**

**Limit:** → 30MHz to 88MHz: 29.5dBμV/m or 100μV/m  
88MHz to 216MHz: 33dBμV/m or 150μV/m  
216MHz to 960MHz: 35.5dBμV/m or 200μV/m  
Above 960MHz: 43.5dBμV/m or 500μV/m

**In-Band Emissions**

The "In band emission" is measured 20dB below the peak power. RBW=3kHz VBW=10kHz

| Frequency (MHz) | Measure (kHz) | Limit (kHz) |
|-----------------|---------------|-------------|
| Fmin            | <b>103,5</b>  | 150         |
| Fnom            | <b>103,5</b>  | 150         |
| Fmax            | <b>103,5</b>  | 150         |

**Result: PASS**

**Limit:** → Emissions within the MEDRADIO band (402 – 405 MHz) more than 150 kHz away from the center frequency of the spectrum the transmission is intended to occupy will be attenuated below the transmitter output power by at least 20 dB

**See graphics in annex 1**

**Band-Edge Emissions**

The "In band emission" is measured 20dB below the peak power. RBW=3kHz VBW=10kHz

| Frequency (MHz) | Measure (MHz)  | Limit (MHz)  |
|-----------------|----------------|--------------|
| Fmin            | <b>402,046</b> | Above 401,75 |
| Fmax            | <b>404,95</b>  | Below 405,25 |

**Result: PASS**

**Limit:** → Emissions 250 kHz or less that are above and below the MEDRADIO band (402 – 405 MHz) will be attenuated below the maximum permitted output power by at least 20 dB.

**See graphics in annex 1**





## 8. RECEIVER SPURIOUS RADIATION & SECONDARY RADIATED EMISSION

### 8.1. TEST CONDITIONS

Test performed by : Stéphane PHOUDIAH  
Date of test : 2012/03/26  
Ambient temperature : 23°C  
Relative humidity : 30%

### 8.2. TEST SETUP

ETSI EN 301 839-1 §9.1

Specified low-power radio equipment (Item 8 of Article 2 Paragraph 1 of Certification Ordinance)

The test is performed on EUT in reception mode.

- **Method of measurement**

- Effective Radiated Power, cabinet radiation
- Effective Radiated Power, cabinet and antenna radiation

- **Qualification measurements on an open test site (25MHz to 200MHz):**

The setup is 1.5m above the ground reference plane.

Distance between measuring antenna and the EUT is 10 meters for frequency 30MHz to 200MHz.

Test is performed in horizontal (H) and vertical (V) polarization with a bilog antenna below 1GHz and with a horn antenna above 1GHz. Measurement bandwidth was 100kHz. Continuous linear turntable azimuth search was performed with 360 degrees range. Vertical search was performed between 1m and 4m with the measuring antenna.

The Substitution Method is applied on the maximum values observed during the azimuth and vertical search in order to obtain the spurious radiated emission.

- **Qualification measurements in full anechoic chamber (200MHz to 4GHz):**

The setup is 1.5m above the ground reference plane.

Distance between measuring antenna and the EUT is 3meters for frequency 200MHz to 4GHz.

Test is performed in horizontal (H) and vertical (V) polarization with a bilog antenna below 1GHz and with a horn antenna above 1GHz. Measurement bandwidth was 100kHz for measurement below 1GHz and 1MHz for measurement above 1GHz. Continuous linear turntable azimuth search was performed with 360 degrees range.

The Normalized Site Attenuation (NSA) is added to the maximum values observed during the azimuth search in order to obtain the spurious radiated emission.

**8.3. RESULTS****• Characterization on open test site (25MHz to 200MHz):**

Vertical antenna

| Operating       |                     |             |
|-----------------|---------------------|-------------|
| Frequency (MHz) | Measure E.R.P (dBm) | Limit (dBm) |
| 32.2            | -64                 | -57         |
| 33.3            | -65                 | -57         |
| 34.5            | -65                 | -57         |
| 35.3            | -66                 | -57         |
| 36.1            | -65                 | -57         |
| 37.4            | -67                 | -57         |
| 39              | -66                 | -57         |
| 40              | -65                 | -57         |
| 41.3            | -70                 | -57         |
| 44.7            | -67                 | -57         |
| 48              | -65                 | -57         |
| 49.9            | -68                 | -57         |
| 52.9            | -67                 | -57         |
| 60              | -62                 | -57         |
| 64              | -65                 | -57         |
| 67.1            | -67                 | -57         |
| 72              | -66                 | -57         |
| 77.1            | -68                 | -57         |
| 80              | -65                 | -57         |
| 116             | -64                 | -57         |
| 120             | -64                 | -57         |
| 144.4           | -66                 | -57         |
| 156.4           | -67                 | -57         |
| 166.6           | -69                 | -57         |
| 175.9           | -65                 | -57         |
| 199.8           | -65                 | -57         |



Horizontal antenna

| Operating       |                     |             |
|-----------------|---------------------|-------------|
| Frequency (MHz) | Measure E.R.P (dBm) | Limit (dBm) |
| 32.9            | -65                 | -57         |
| 40              | -64                 | -57         |
| 50.3            | -68                 | -57         |
| 59.3            | -69                 | -57         |
| 67.1            | -65                 | -57         |
| 74.5            | -69                 | -57         |
| 133             | -64                 | -57         |
| 144             | -64                 | -57         |
| 166             | -69                 | -57         |
| 200.3           | -64                 | -57         |

- **Characterization in full anechoic chamber (200MHz to 4GHz):**

| Frequency (MHz) | Measure E.R.P (dBm) | Measure E.I.R.P (dBm) |
|-----------------|---------------------|-----------------------|
| 3966,7          | -57,71              | 55,71                 |
| 3506,6          | -58,70              | -56,70                |
| 986,9           | -68,37              | -66,37                |

**Limit:** → -57dBm below 1000 MHz  
-47dBm above 1000 MHz

Specified low-power radio equipment (Item 8 of Article 2 Paragraph 1 of Certification Ordinance)

**Limit:** → -54dBm

**Result:** **PASS**

See graphics in annex 1



## 9. RADIATION EMISSIONS

### 9.1. TEST CONDITIONS

Test performed by : Laurent DENEUX  
Date of test : 2012/03/20  
Ambient temperature : 21°C  
Relative humidity : 48%

### 9.2. TEST SETUP

FCC 15.109  
RSS 243 §3.5

The test is performed on EUT in reception mode.

- **Method of measurement**

- Effective Radiated Power, cabinet radiation
- Effective Radiated Power, cabinet and antenna radiation

- **Qualification measurements on an open test site (30MHz to 25GHz):**

The setup is 1.5m above the ground reference plane.

Distance between measuring antenna and the EUT is 10 meters for frequency 30MHz to 25GHz.

Test is performed in horizontal (H) and vertical (V) polarization with a bilog antenna below 1GHz and with a horn antenna above 1GHz . Measurement bandwidth was 100kHz and 1MHz for measurement above 1GHz. Continuous linear turntable azimuth search was performed with 360 degrees range. Vertical and horizontal search was performed between 1m and 4m with the measuring antenna.



**9.3. RESULTS**

• **Characterization on open test site (30MHz to 25GHz):**

Fcc Part.15 CLASS B

SORIN  
IMPLANT  
MODEL : PARADYM RF CRT D 9750  
400 Rx

Quasi peak measurement

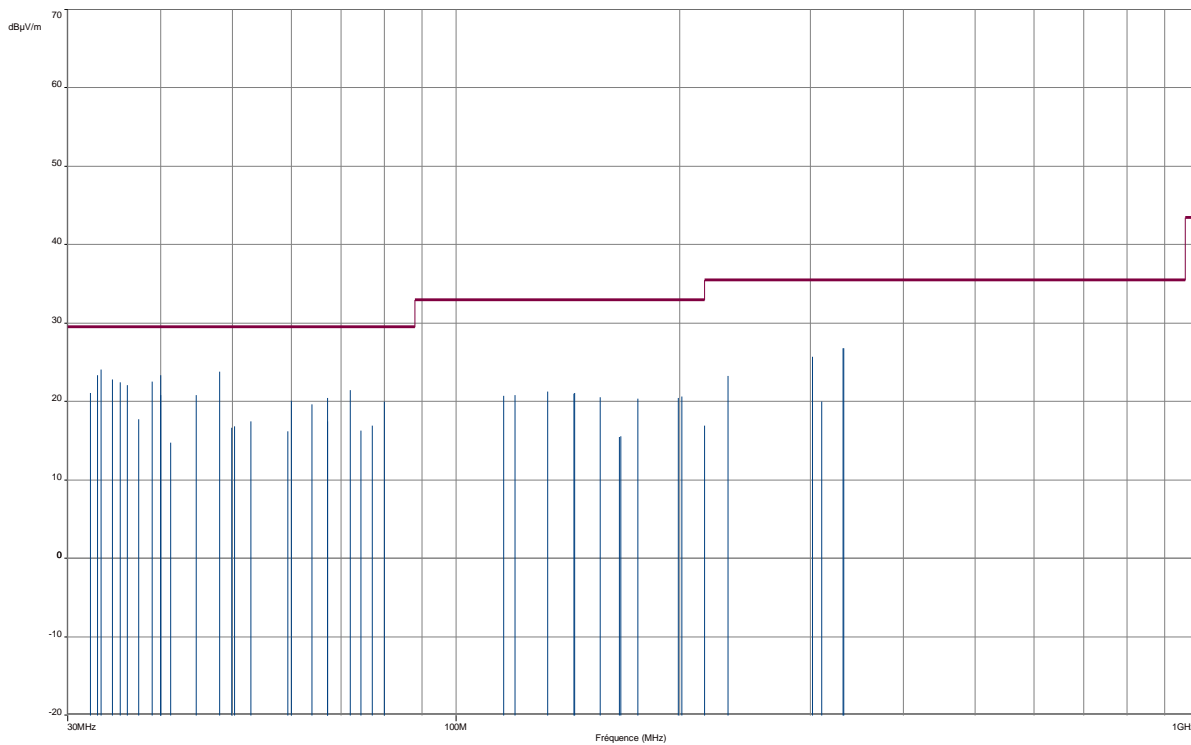

— Limit level

**Remark:** During the Scan, no radiated emission has been detected in the frequency range 1 GHz to 25 GHz.

**Result:** **PASS**

**Limit:** → 30MHz to 88MHz: 29.5BµV/m or 100µV/m  
88MHz to 216MHz: 33dBµV/m or 150µV/m  
216MHz to 960MHz: 35.5dBµV/m or 200µV/m  
Above 960MHz: 43.5dBµV/m or 500µV/m



**10. TEST EQUIPMENT LIST**

| Test  | Apparatus             | Trade Mark          | Type            | Registration number |
|---|-----------------------|---------------------|-----------------|---------------------|
| <b>Effective Radiated Power Of The Fundamental Emission, Maximum Transmitter Power, Antenna Power</b> |                       |                     |                 |                     |
| X   | Full anechoic chamber | SIEPEL              | S36             | D3044019            |
| X   | Logperiodic antenna   | AMPLIFIER RESEARCH  | ATR80M6G        | C2040149            |
| X   | EMI Test Receiver     | ROHDE & SCHWARZ     | ESMI            | A2642009            |
| X   | Signal Generator      | ROHDE & SCHWARZ     | SMIQ03b         | A5442039            |
| X   | Logperiodic antenna   | AMPLIFIER RESEARCH  | AT1000          | C2040002            |
| X   | Substitution Cable    | -                   | CNJ01           | A5329393            |
| X   | Substitution Cable    | -                   | CNS1E 04        | A5329434            |
| X   | Horn Antenna          | A.H. SYSTEMS        | SAS-571         | C2042041            |
| X   | Horn Antenna          | EMCO                | 3117            | C2042031            |
| X   | Dipole Antenna        | SCHWARZBECK         | VHAP            | C2040020            |
| X   | Dipole Antenna        | SCHWARZBECK         | UHAP            | C2040022            |
| <b>Emission Bandwidth, Occupied Bandwidth, Band-Edge Emissions, In-Band Emissions</b>                 |                       |                     |                 |                     |
| X   | Antenna               | KATHREIN            | -               | -                   |
| X   | Climatic Chamber      | SECASI Technologies | SLT-34          | D1024029            |
| X   | Spectrum Analyser     | ROHDE & SCHWARZ     | FSL             | A4060032            |
| <b>Frequency error &amp; Frequency stability</b>  |                       |                     |                 |                     |
| X   | Spectrum Analyser     | ROHDE & SCHWARZ     | FSL             | A4060032            |
| X   | Antenna               | KATHREIN            | -               | -                   |
| X   | Climatic Chamber      | SECASI Technologies | SLT-34          | D1024029            |
| <b>Transmitter Spurious Emissions &amp; Unwanted Emissions</b>  |                       |                     |                 |                     |
| X   | Full anechoic chamber | SIEPEL              | S36             | D3044019            |
| X   | EMI Test Receiver     | ROHDE & SCHWARZ     | ESMI            | A2642009            |
| X   | Preamplifier          | BONN Elektronik     | BLNA 3018-8F30S | A7080053            |
| X   | Horn Antenna          | A.H. SYSTEMS        | SAS-571         | C2042041            |
| X   | Logperiodic antenna   | AMPLIFIER RESEARCH  | ATR80M6G        | C2040149            |
| X   | Signal Generator      | ROHDE & SCHWARZ     | SMR             | A5444002            |
| X   | Signal Generator      | ROHDE & SCHWARZ     | SMIQ03b         | A5442039            |
| X   | Dipole Antenna        | SCHWARZBECK         | VHAP            | C2040020            |
| X   | Dipole Antenna        | SCHWARZBECK         | UHAP            | C2040022            |
| X   | Open test site        | LCIE                | -               | F2000400            |
| X   | EMI Test Receiver     | ROHDE & SCHWARZ     | ESU             | A2642018            |
| X   | Preamplifier          | HEWLETT PACKARD     | 8449B           | A4069002            |
| X   | Bilog antenna         | CHASE               | CBL 6112A       | C2040040            |
| X   | Dipole                | ROHDE & SCHWARZ     | HUF-Z1          | C2040011            |
| X   | Logperiodic antenna   | ROHDE & SCHWARZ     | HL 023 A2       | C2040001            |
| X   | Horn antenna          | EMV                 | 3115            | C2040023            |
| X   | Horn antenna          | AH SYSTEMS          | SAS-572         | C2042026            |
| X   | Horn antenna          | EMCO                | .3115           | C2042016            |
| X   | Signal Generator      | ROHDE & SCHWARZ     | SMP02           | B2163019            |
| X   | Signal Generator      | ROHDE & SCHWARZ     | SMY02           | A5442014            |
| <b>Receiver Spurious Emissions &amp; Radiated Emissions</b>   |                       |                     |                 |                     |
| X   | Full anechoic chamber | SIEPEL              | S36             | D3044019            |
| X   | EMI Test Receiver     | ROHDE & SCHWARZ     | ESMI            | A2642009            |
| X   | Preamplifier          | BONN Elektronik     | BLNA 3018-8F30S | A7080053            |
| X   | Horn Antenna          | A.H. SYSTEMS        | SAS-571         | C2042041            |
| X   | Logperiodic antenna   | AMPLIFIER RESEARCH  | ATR80M6G        | C2040149            |
| X   | Signal Generator      | ROHDE & SCHWARZ     | SMR             | A5444002            |
| X   | Signal Generator      | ROHDE & SCHWARZ     | SMIQ03b         | A5442039            |
| X   | Dipole Antenna        | SCHWARZBECK         | VHAP            | C2040020            |
| X   | Dipole Antenna        | SCHWARZBECK         | UHAP            | C2040022            |
| X   | Open test site        | LCIE                | -               | F2000400            |
| X   | EMI Test Receiver     | ROHDE & SCHWARZ     | ESU             | A2642018            |
| X   | Preamplifier          | HEWLETT PACKARD     | 8449B           | A4069002            |
| X   | Bilog antenna         | CHASE               | CBL 6112A       | C2040040            |
| X   | Dipole                | ROHDE & SCHWARZ     | HUF-Z1          | C2040011            |
| X   | Logperiodic antenna   | ROHDE & SCHWARZ     | HL 023 A2       | C2040001            |
| X   | Horn antenna          | EMV                 | 3115            | C2040023            |



|   |                  |                 |         |          |
|---|------------------|-----------------|---------|----------|
| X | Horn antenna     | AH SYSTEMS      | SAS-572 | C2042026 |
| X | Horn antenna     | EMCO            | .3115   | C2042016 |
| X | Signal Generator | ROHDE & SCHWARZ | SMP02   | B2163019 |

**11. UNCERTAINTIES CHART**

|   | Measurement uncertainties<br>(k=2) ±x(dB) / (Hz) | Limit for uncertainties<br>±y(dB) |
|---|--|-----------------------------------|
| <b>TRANSMITTER REQUIREMENTS</b>   |  |                                   |
| Frequency Error   | ±2.10 <sup>-8</sup> Hz                           | ±1.10 <sup>-7</sup> Hz            |
| Modulation Bandwidth  | ± 100 kHz  | -                                 |
| Effective Radiated Power  | ±3.9 dB  | ±6 dB                             |
| Adjacent Channel Power  | ±1.6 dB  | ±3 dB                             |
| Spurious emissions <ul style="list-style-type: none"> <li>• Frequency &lt; 1000 MHz</li> <li>• Frequency &gt; 1000 MHz</li> </ul> | ±3.9 dB<br>±3.1 dB                               | ±6 dB                             |
| Conducted power   | ±0.6 dB  | ±1.5 dB                           |
| Spectral density in conduction  | ±0.6 dB  | ±1.5 dB                           |
| Spurious emissions in conduction  | ±1.6 dB  | ±3 dB                             |
| Temperature   | ±0.5°C   | ±1°C                              |
| Humidity  | ±2.5 %   | ±5 %                              |
| <b>RECEIVER REQUIREMENTS</b>  |  |                                   |
| Spurious emissions <ul style="list-style-type: none"> <li>• Frequency &lt; 1000 MHz</li> <li>• Frequency &gt; 1000 MHz</li> </ul> | ±3.9 dB<br>±3.1 dB                               | ±6 dB                             |
| Spurious emissions in conduction  | ±0.6 dB  | ±3 dB                             |



**12. ANNEX 1 (GRAPHS)**

Frequency: Fmin  
Frequency error  
Temperature: Tmin  
Voltage: Vnom

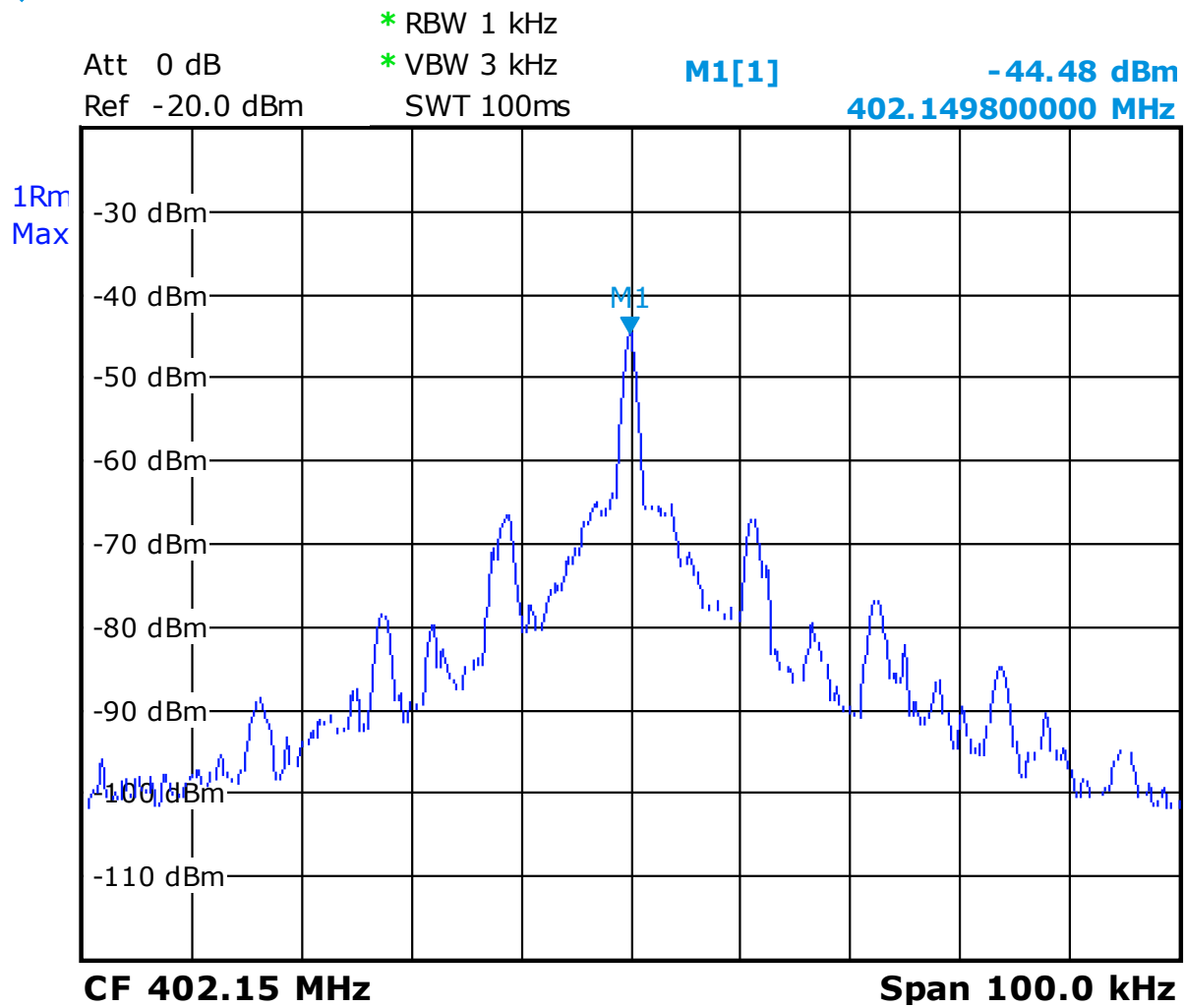

Date: 30.MAR.2012 10:48:10





Frequency: Fmin  
Frequency error  
Temperature: Tnom  
Voltage: Vnom



\* RBW 1 kHz

\* VBW 3 kHz

Att 0 dB

Ref -20.0 dBm

SWT 100ms

M1[1]

-46.27 dBm

402.15120000 MHz

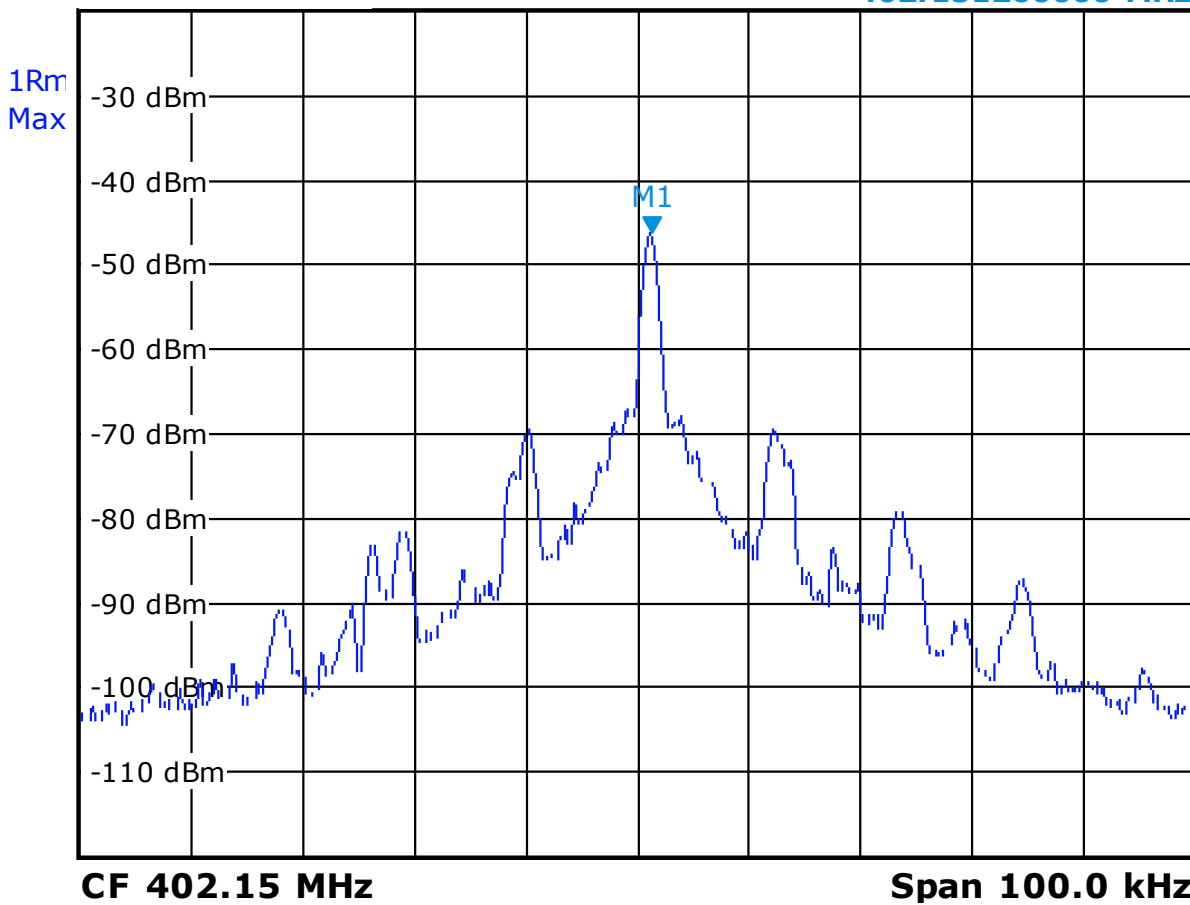

Date: 30.MAR.2012 14:57:10



Frequency: Fmin  
Frequency error  
Temperature: Tmax  
Voltage: Vnom



Att 0 dB      \* RBW 1 kHz  
Ref -20.0 dBm      \* VBW 3 kHz      **M1[1]**      **-47.27 dBm**  
SWT 100ms      **402.15220000 MHz**

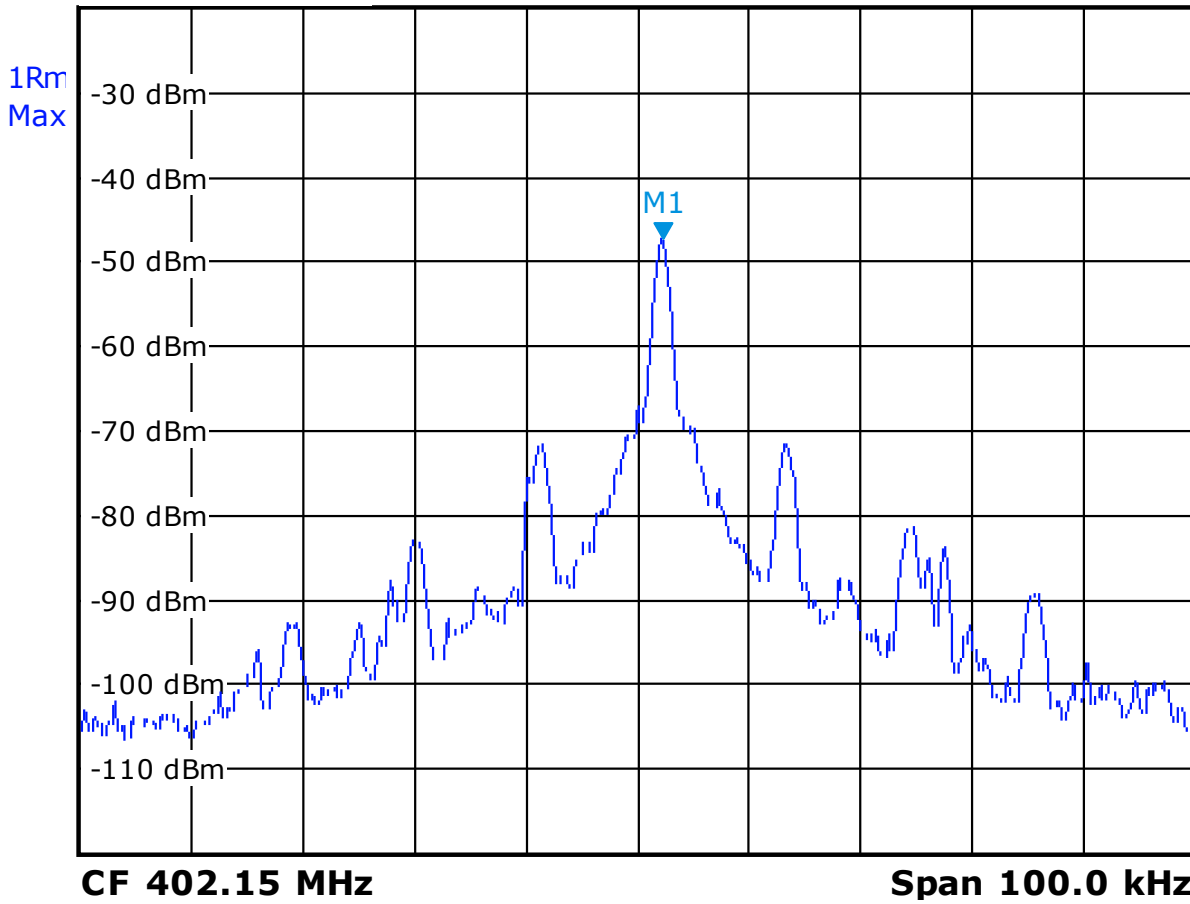

Date: 30.MAR.2012 16:45:40



Frequency: Fnom  
Frequency error  
Temperature: Tmin  
Voltage: Vnom



\* RBW 1 kHz

\* VBW 3 kHz

Att 0 dB

Ref -20.0 dBm

SWT 100ms

M1[1]

-44.92 dBm

403.65399000 MHz

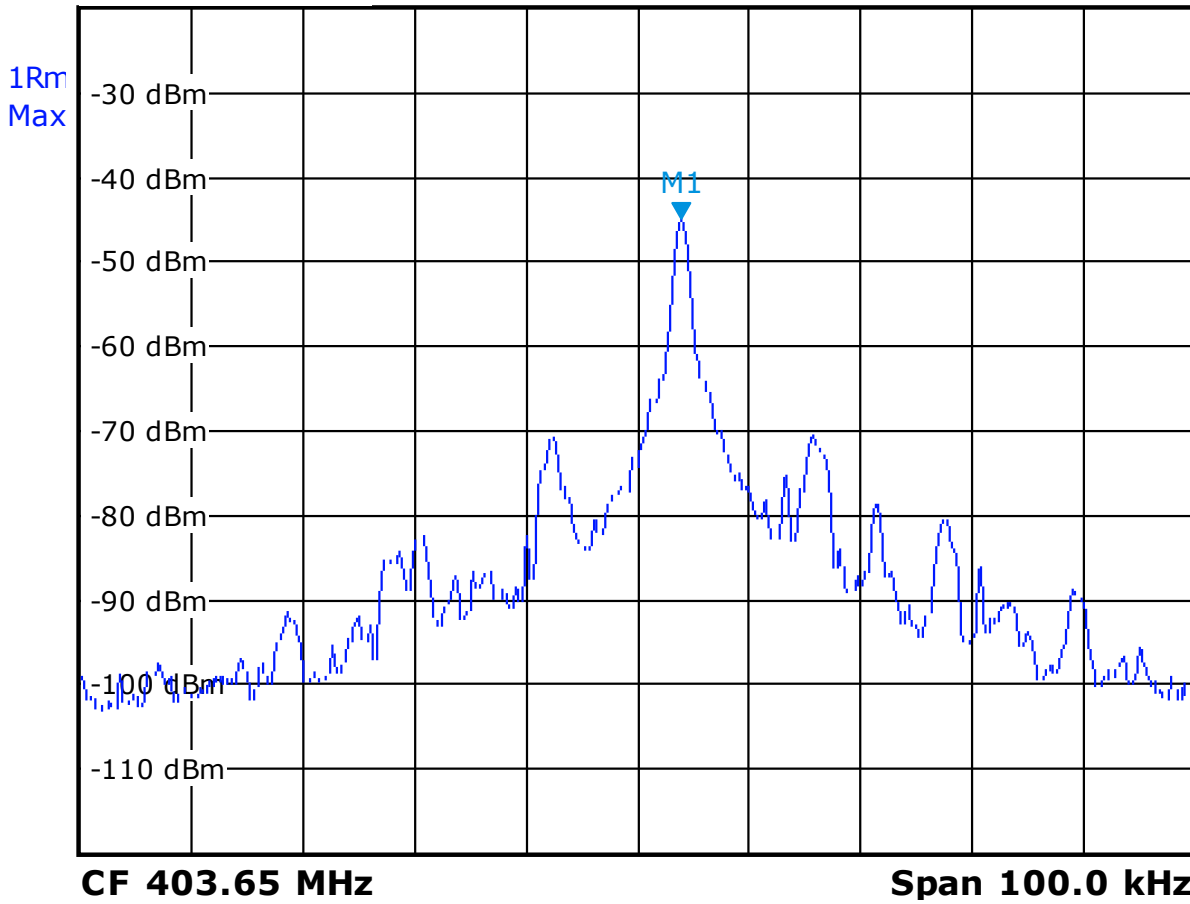

Date: 30.MAR.2012 10:51:37



Frequency: Fnom  
Frequency error  
Temperature: Tnom  
Voltage: Vnom



\* RBW 1 kHz

\* VBW 3 kHz

Att 0 dB

Ref -20.0 dBm

SWT 100ms

M1[1]

-48.37 dBm

403.65359000 MHz

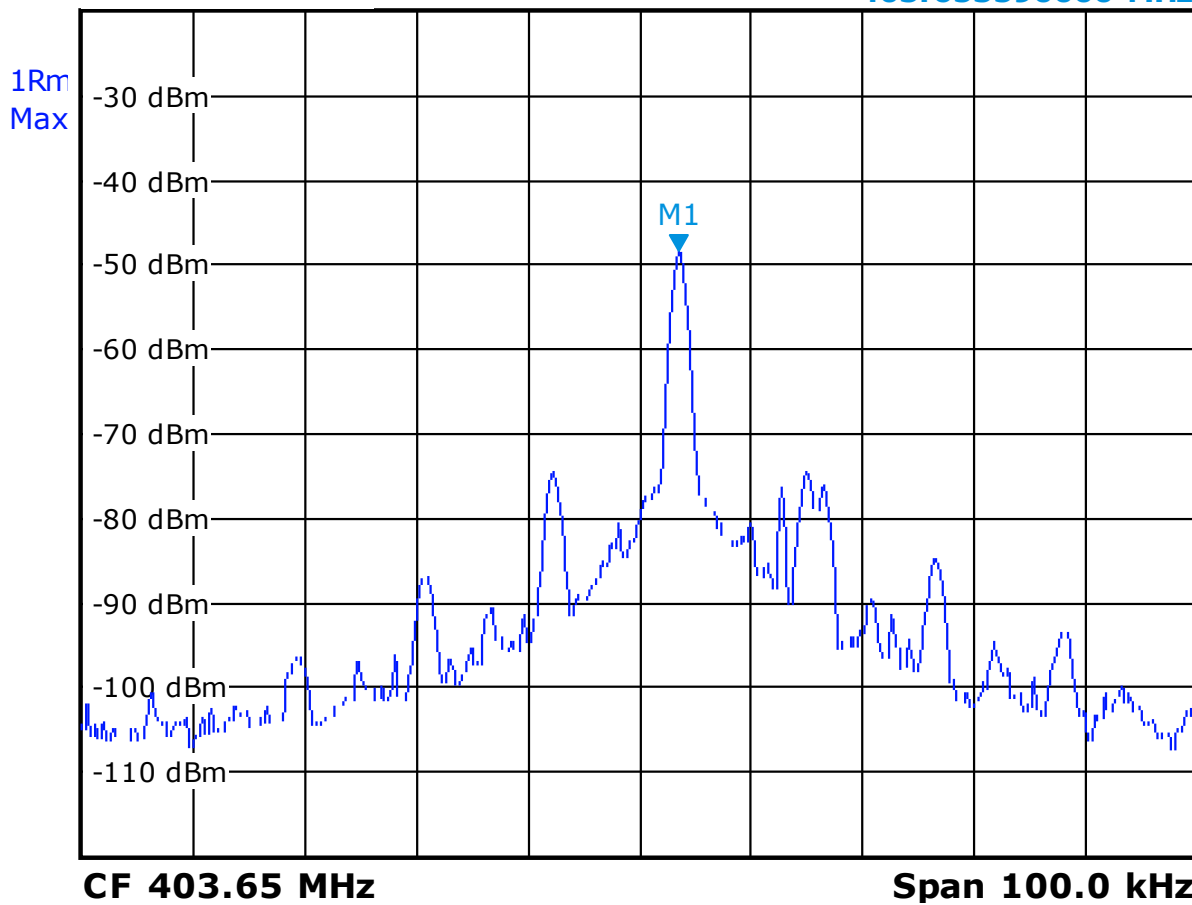

Date: 30.MAR.2012 14:59:23



Frequency: Fnom  
Frequency error  
Temperature: Tmax  
Voltage: Vnom



Att 0 dB      \* RBW 1 kHz      **M1[1]**      **-45.26 dBm**  
Ref -20.0 dBm      \* VBW 3 kHz      **403.65000000 MHz**  
SWT 100ms

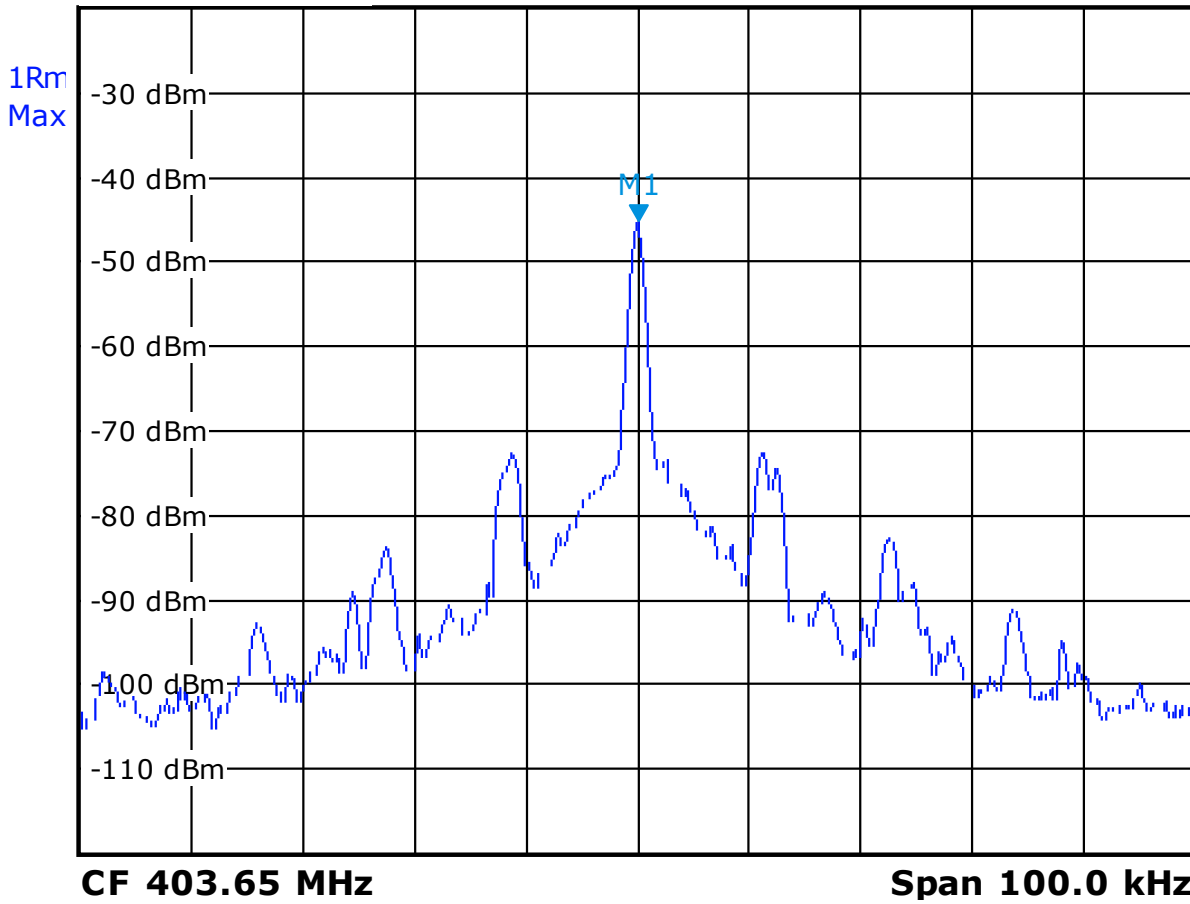



Frequency: Fmax  
Frequency error  
Temperature: Tmin  
Voltage: Vnom



Att 0 dB      \* RBW 1 kHz  
Ref -20.0 dBm      \* VBW 3 kHz      **M1[1]**      **-45.73 dBm**  
SWT 100ms      **404.85399000 MHz**

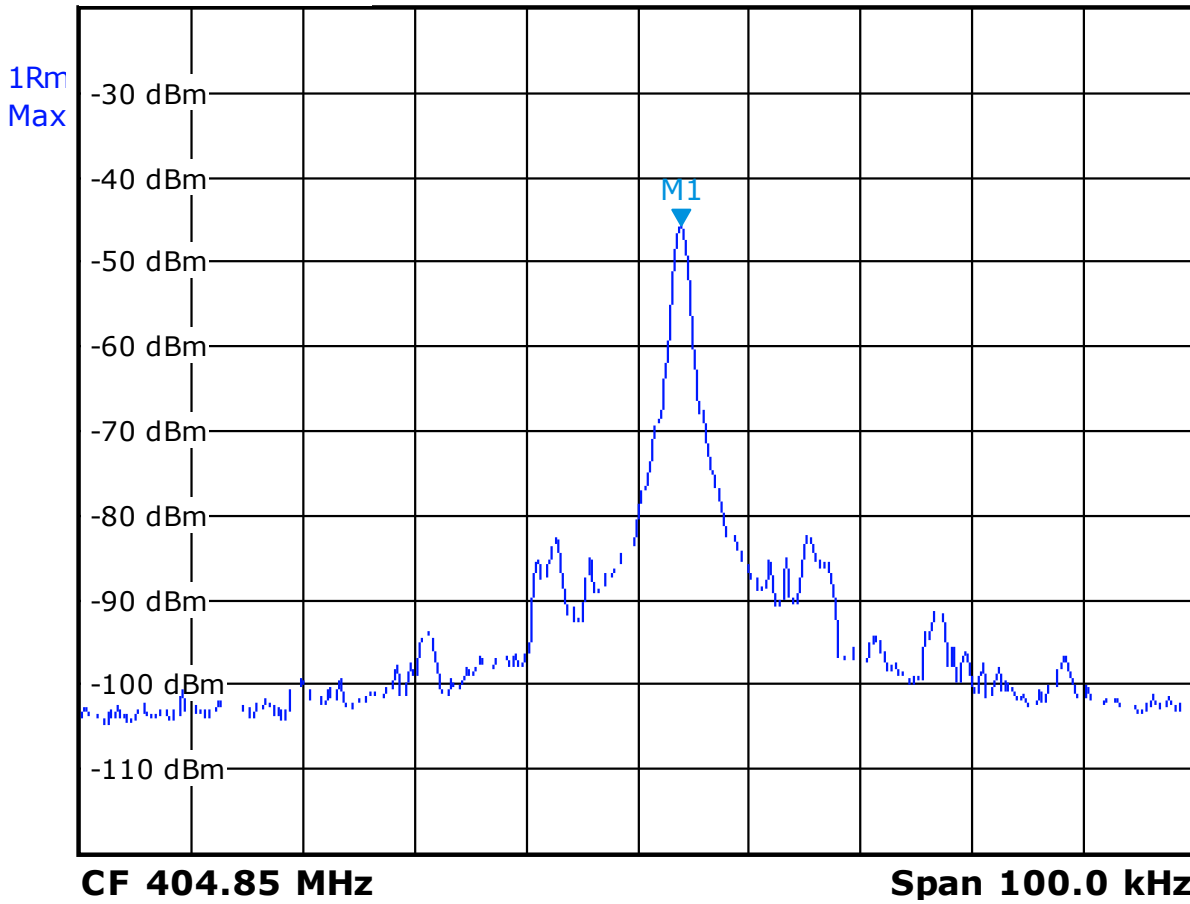

Date: 30.MAR.2012 10:54:06



Frequency: Fmax  
Frequency error  
Temperature: Tnom  
Voltage: Vnom



Att 0 dB      \* RBW 1 kHz  
Ref -20.0 dBm      \* VBW 3 kHz      **M1[1]**      **-47.03 dBm**  
SWT 100ms      **404.85160000 MHz**

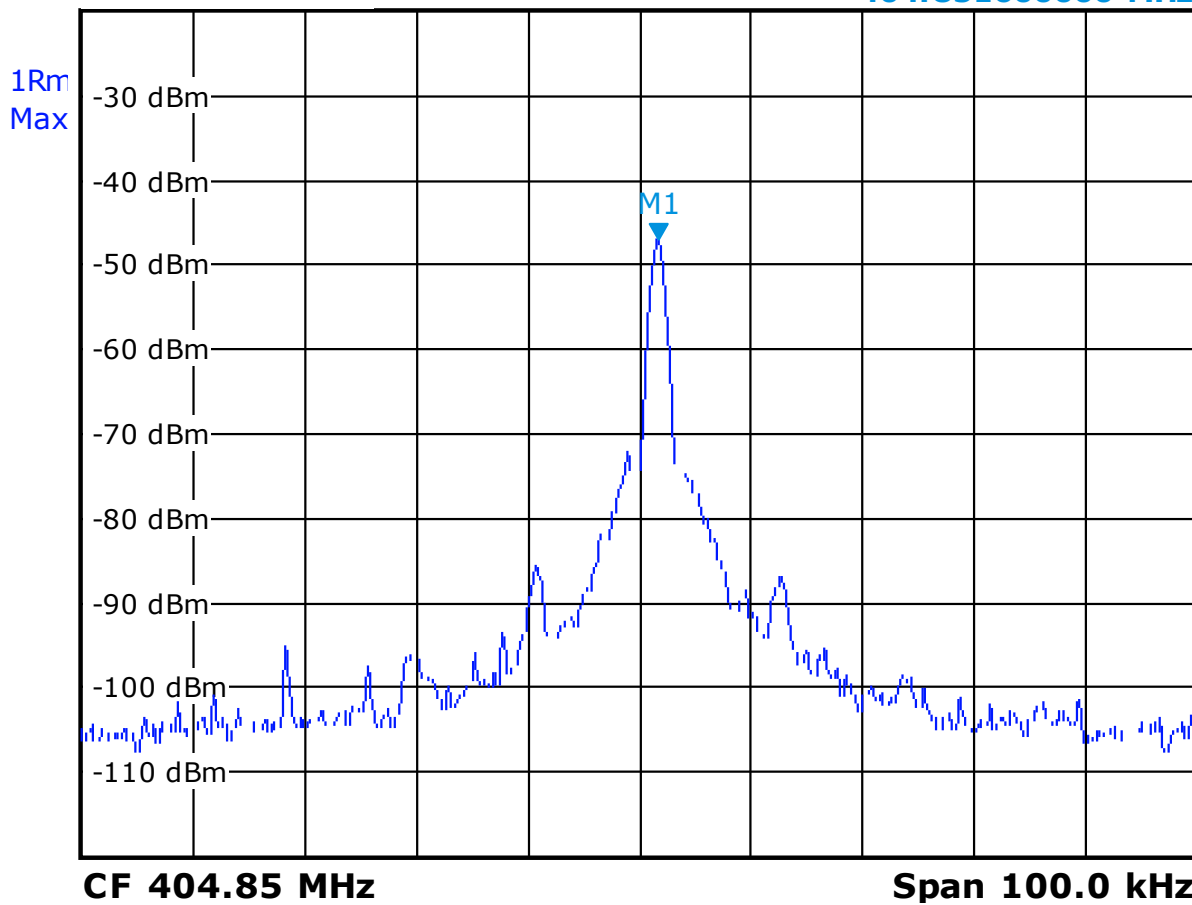

Date: 30.MAR.2012 15:01:46



Frequency: Fmax  
Frequency error  
Temperature: Tmax  
Voltage: Vnom



Att 0 dB      \* RBW 1 kHz  
Ref -20.0 dBm      \* VBW 3 kHz      **M1[1]**      **-47.35 dBm**  
SWT 100ms      **404.853790000 MHz**

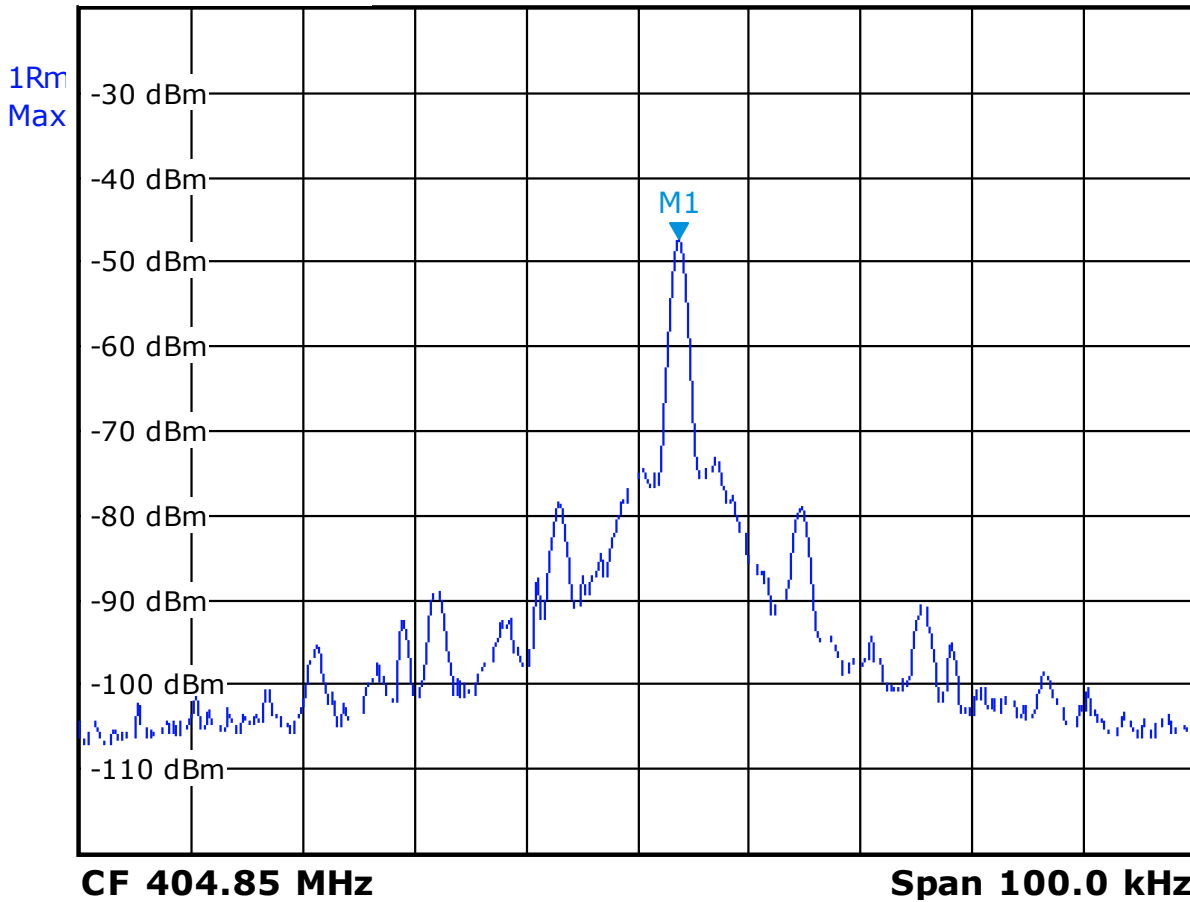



Spurious emissions  
Operating mode  
Vertical polarisation

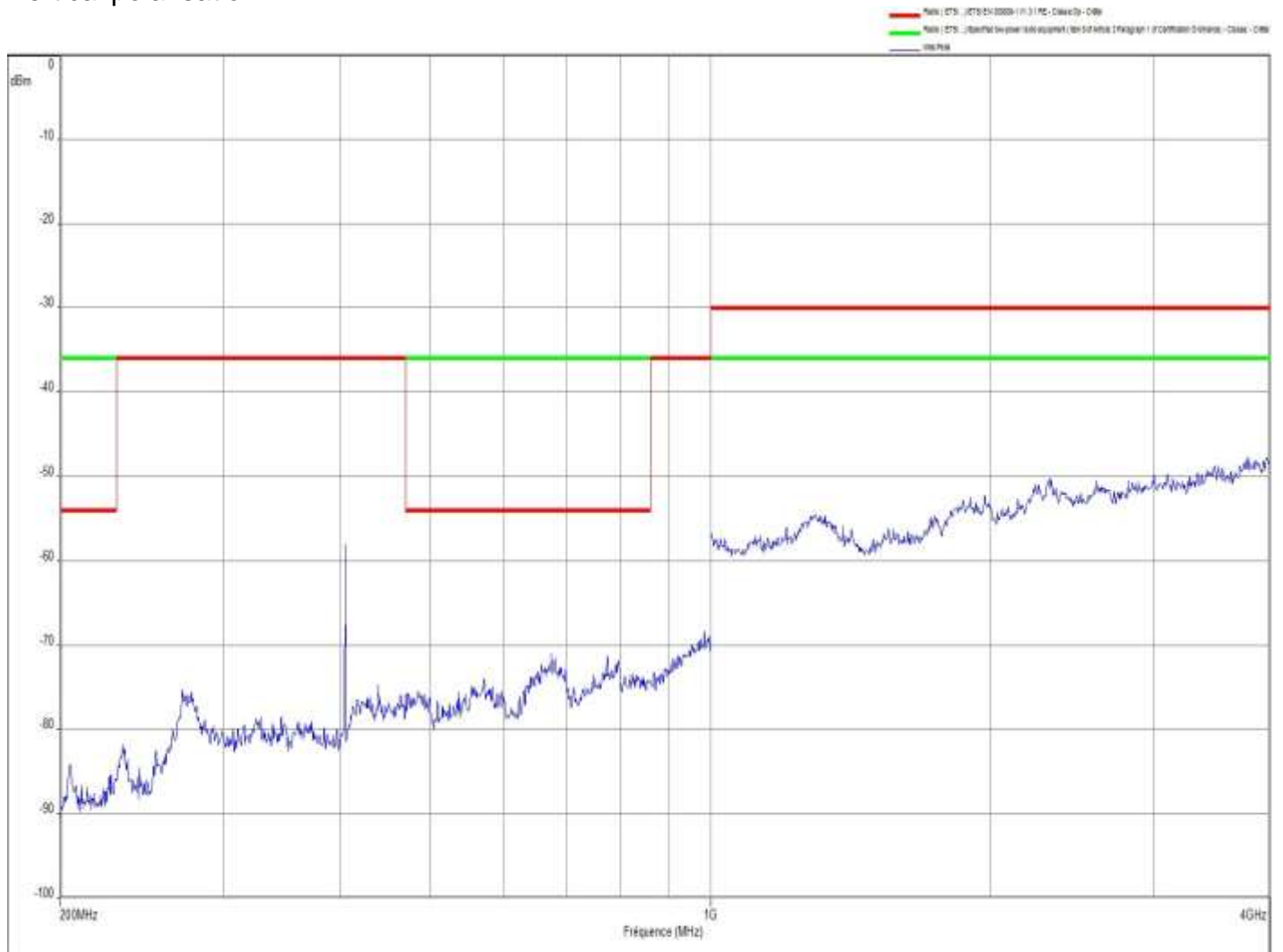

Spurious emissions  
 Operating mode  
 Horizontal polarisation

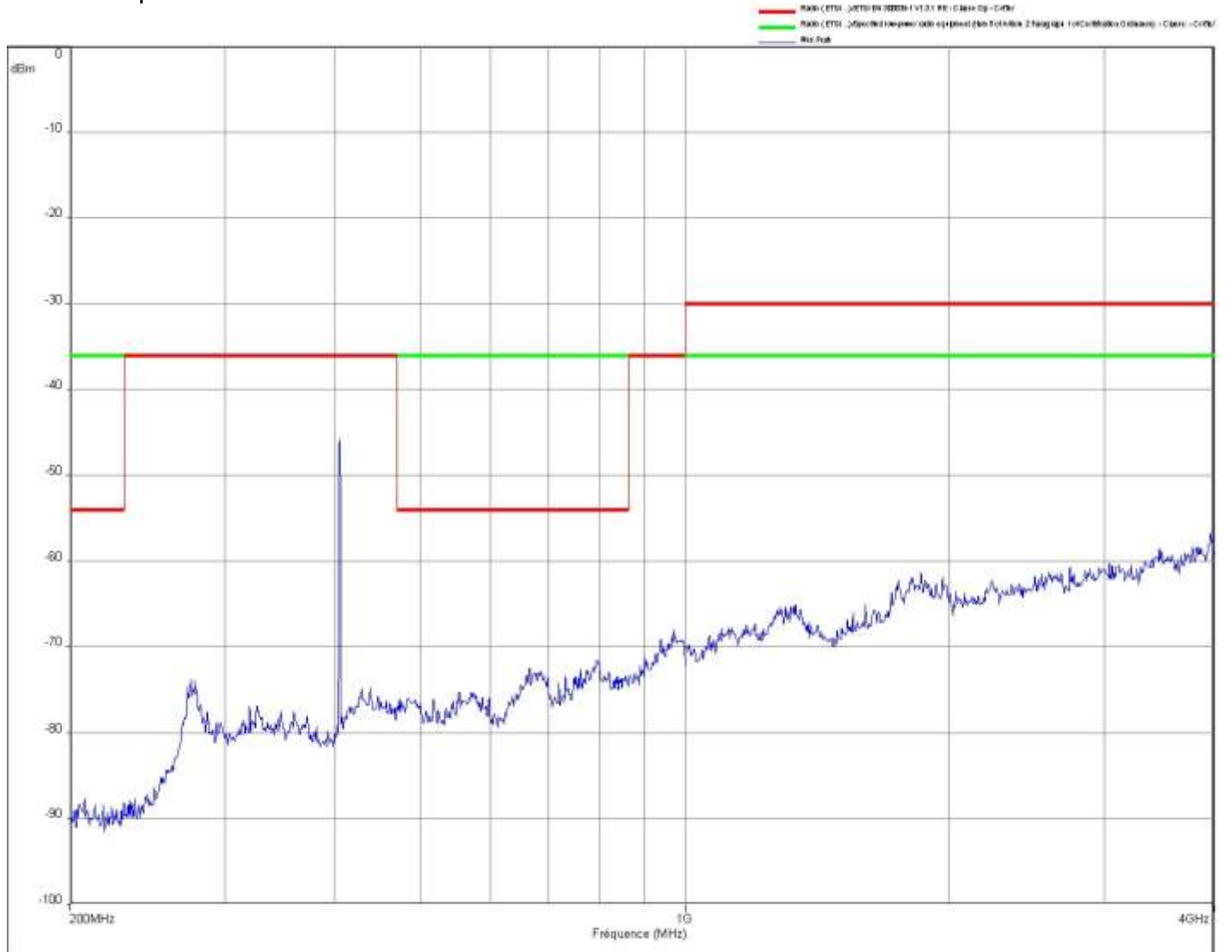



Spurious emissions  
Receiver mode  
Vertical polarisation



Spurious emissions  
Receiver mode  
Horizontal polarisation

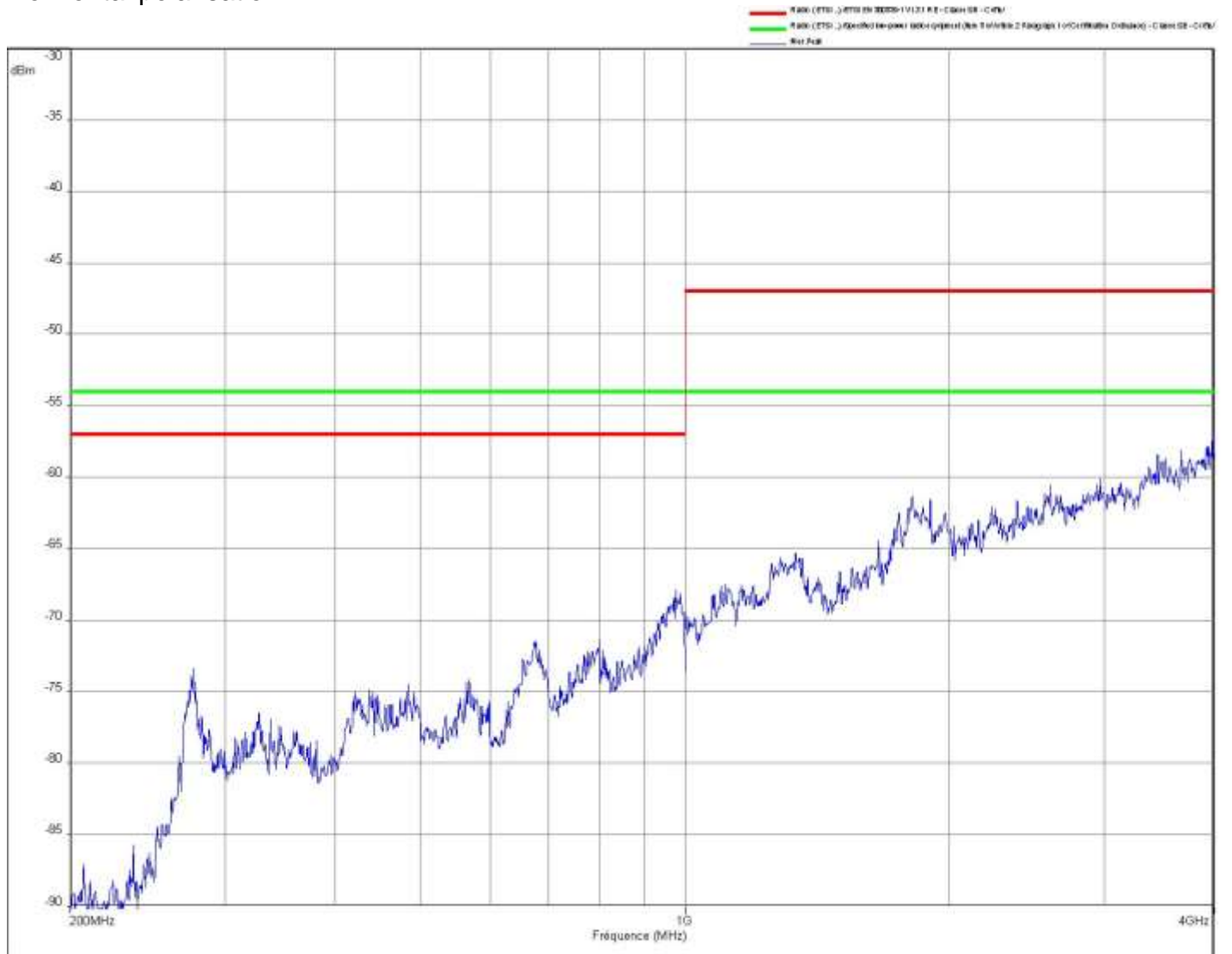



Frequency: Fmin  
Emission Bandwidth  
Band-Edge Emissions  
In-Band Emissions

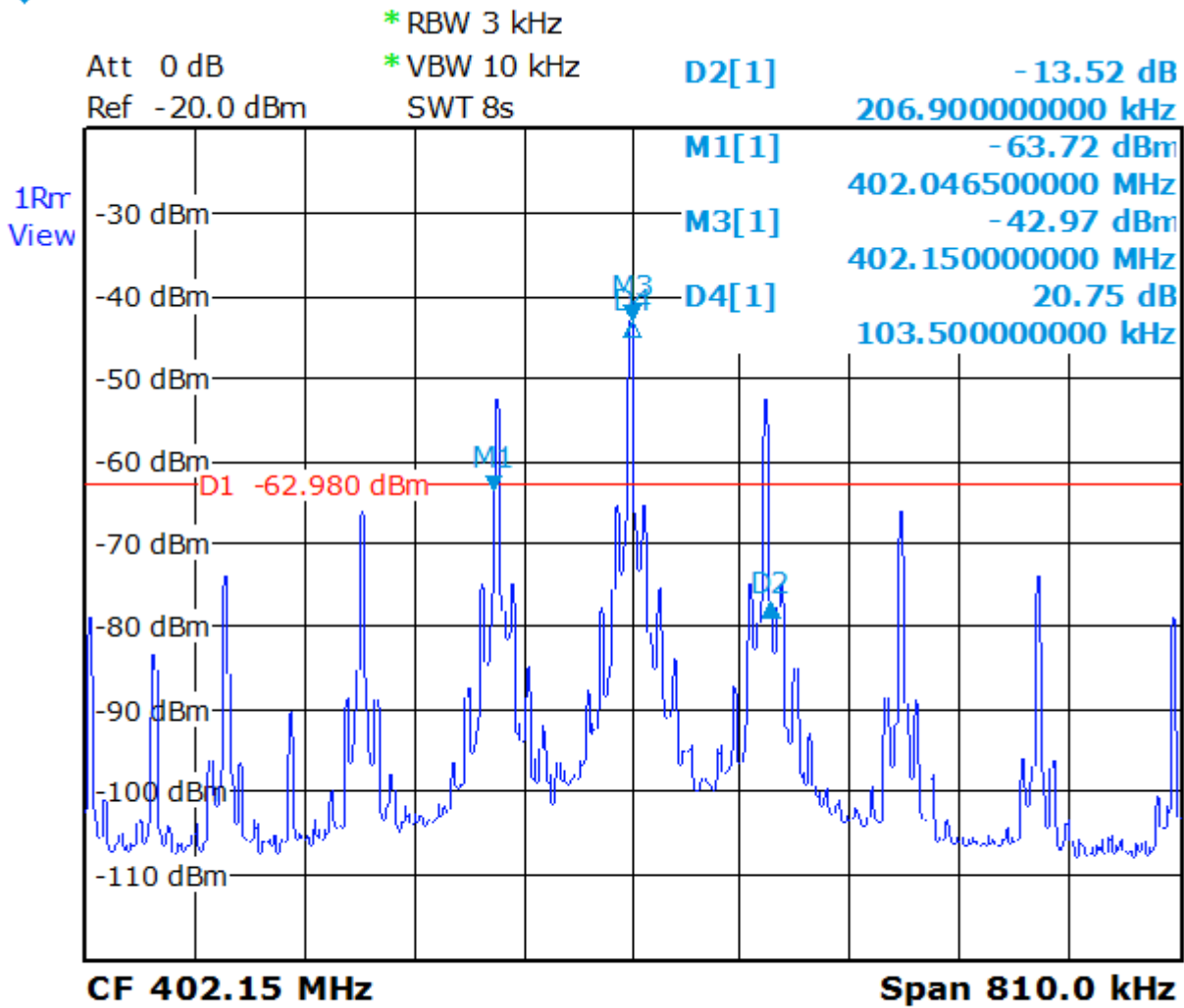

Date: 29.MAR.2012 11:39:59



Frequency: From  
Emission Bandwidth  
In-Band Emissions

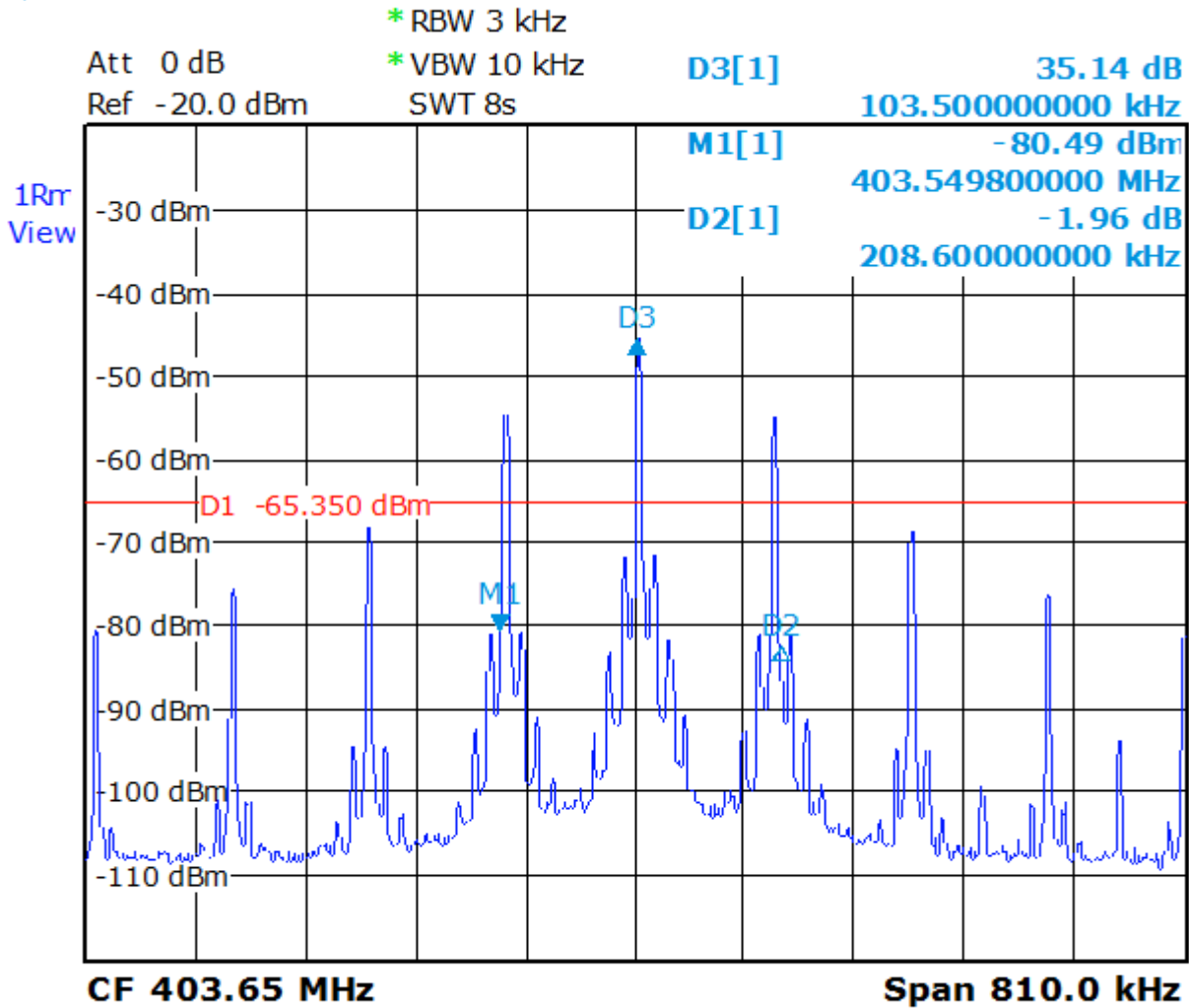

Date: 29.MAR.2012 12:49:02



Frequency: Fmax  
Emission Bandwidth  
Band-Edge Emissions  
In-Band Emission

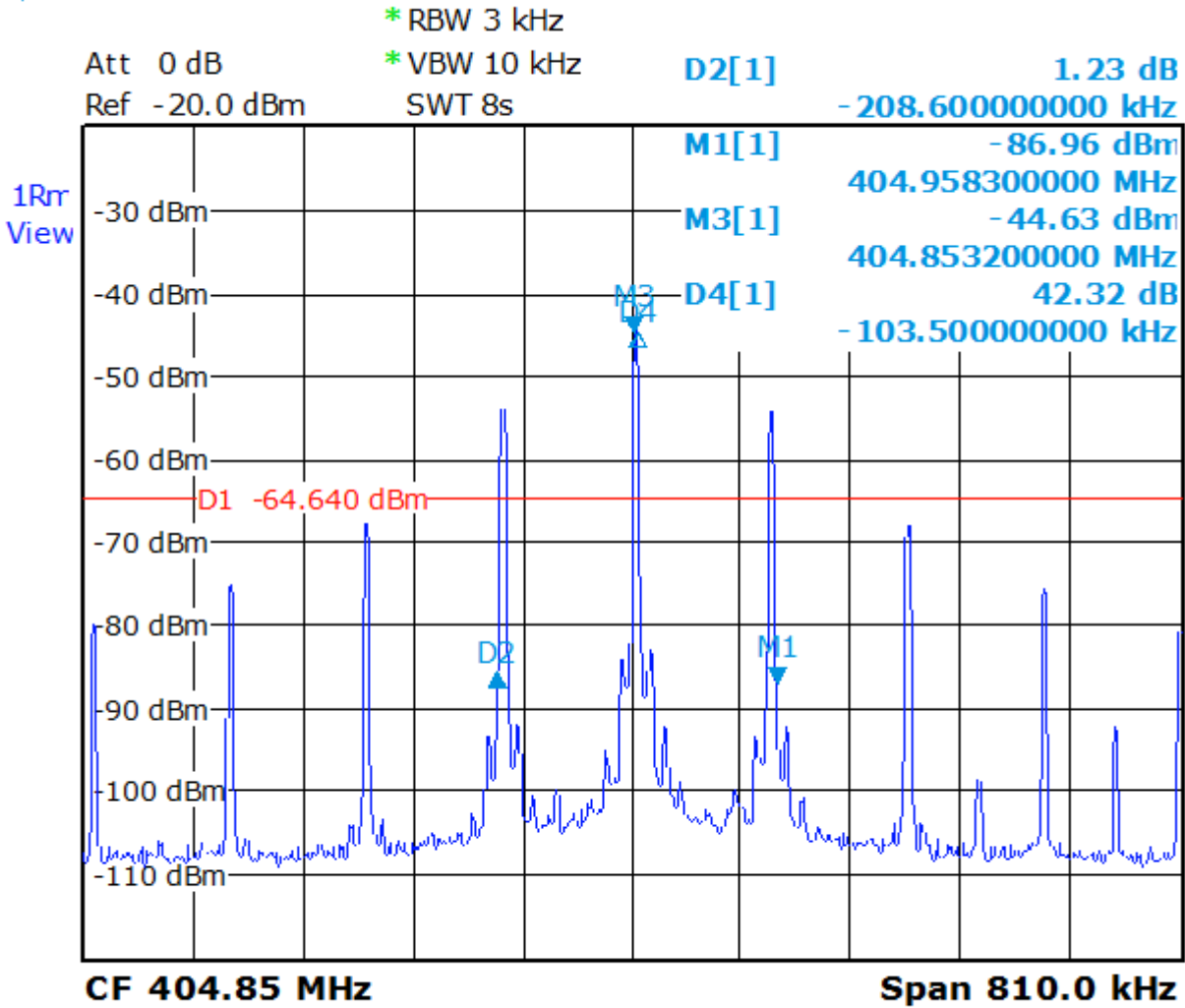

Date: 29.MAR.2012 12:41:20



Frequency: Fmin  
Occupied Bandwidth

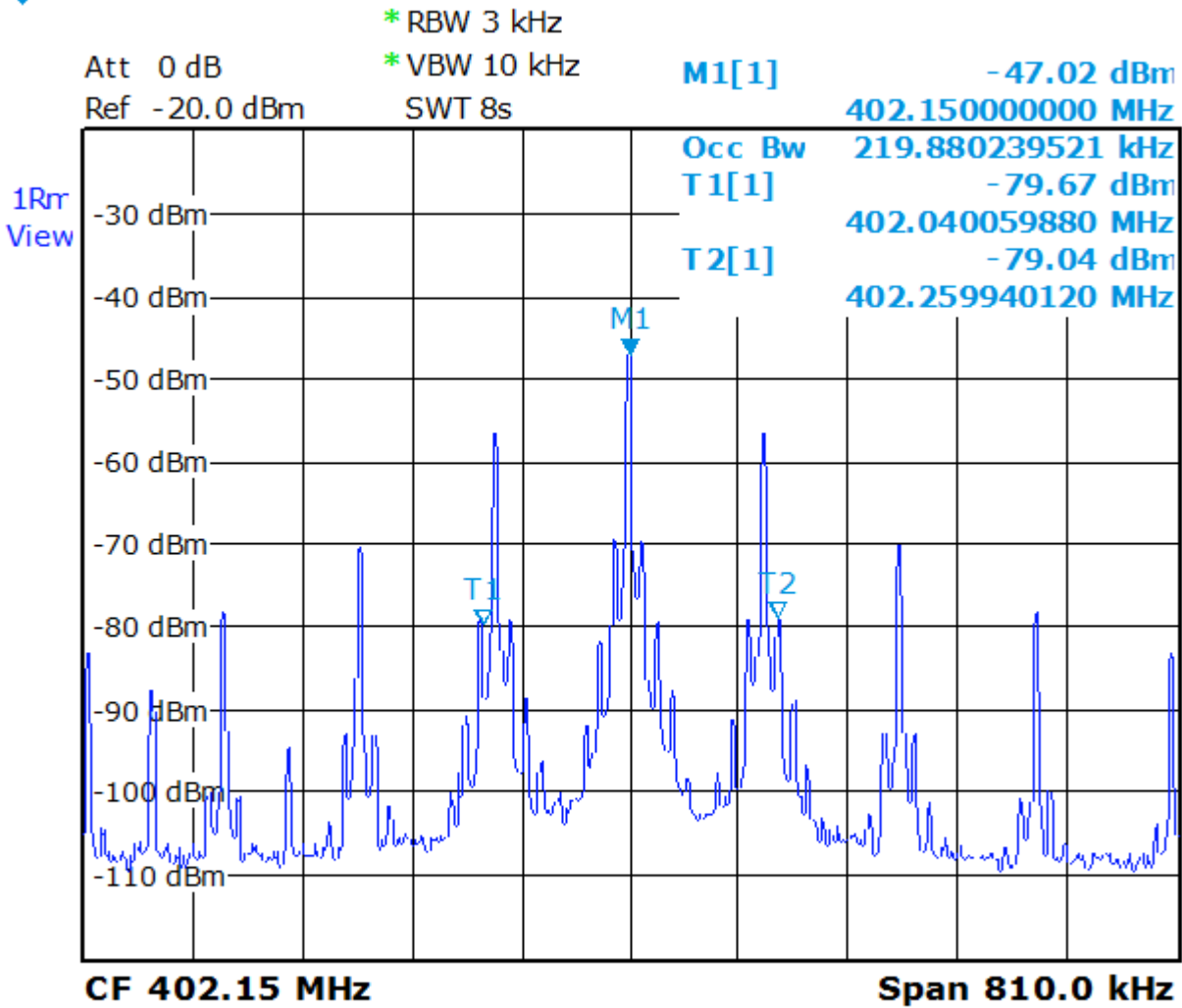

Date: 29.MAR.2012 11:28:04





Frequency: From  
Occupied Bandwidth

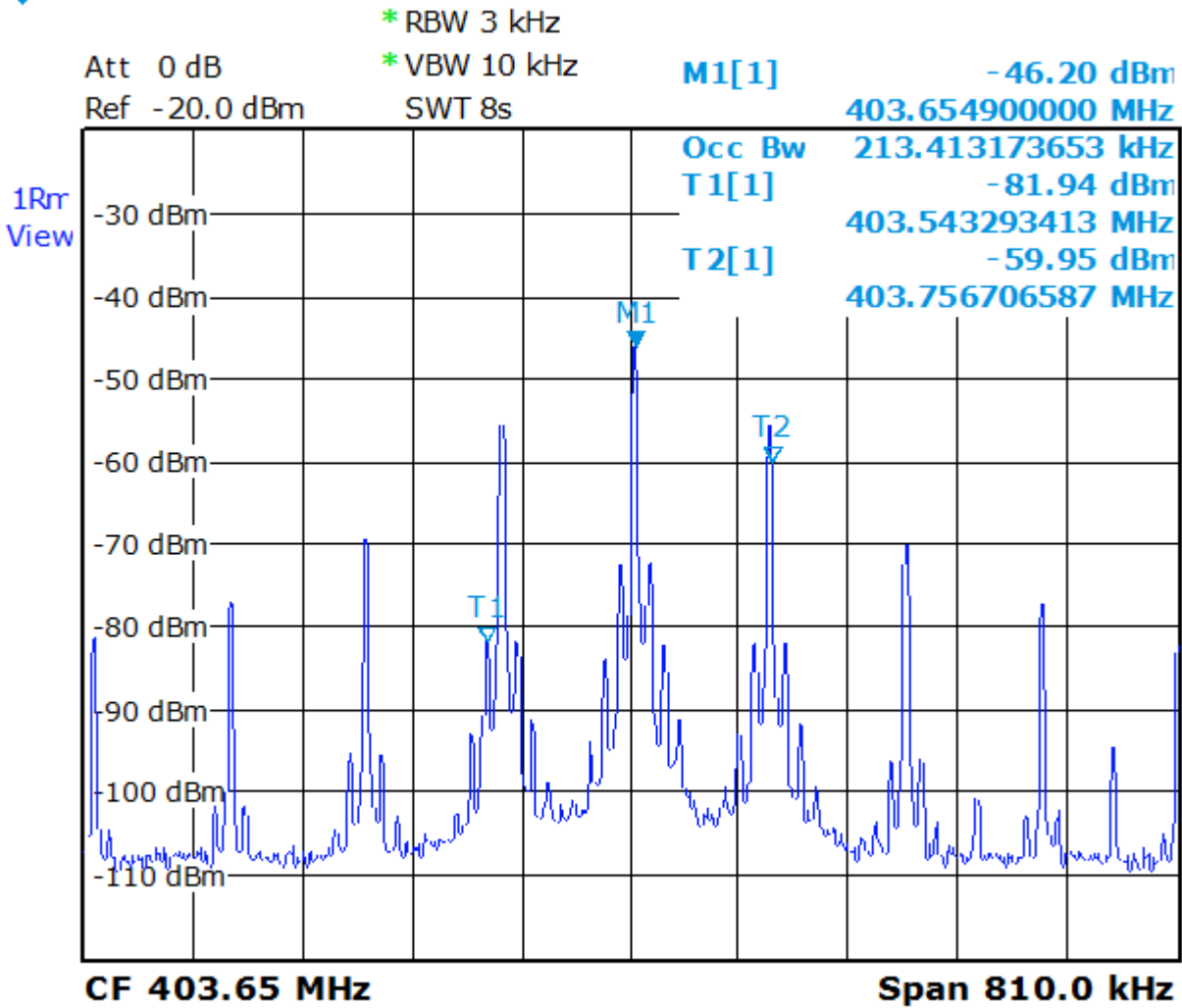

Date: 29.MAR.2012 11:22:51



Frequency: Fmax  
Occupied Bandwidth

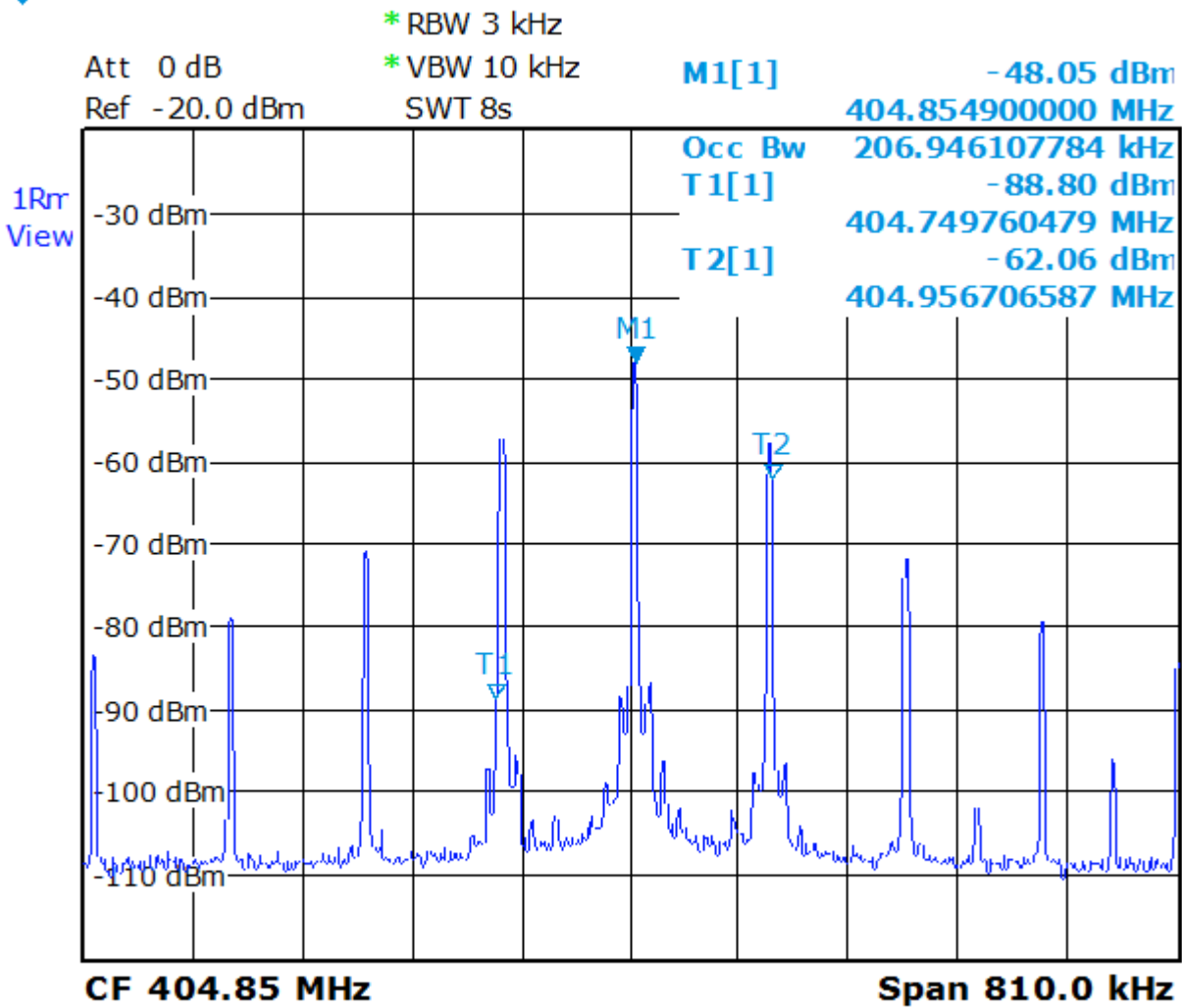

Date: 29.MAR.2012 11:20:42

**13. ANNEX 2 (FLUID DATA SHEET MSL 450)**

Schmid &amp; Partner Engineering AG

**s p e a g**

Zeughausstrasse 43, 8004 Zurich, Switzerland  
Phone +41 44 245 9700, Fax +41 44 245 9779  
info@speag.com, http://www.speag.com

**Material Safety Data Sheet****1 Identification of the substance and of the manufacturer / origin**

|                       |   |
|-----------------------|---|
| Item                  | Brain Tissue Simulation Liquids B900<br>Head Tissue Simulation Liquids HSL 175, HSL300, HSL450, HSL750,<br>HSL900<br>Muscle Tissue Simulation Liquids MBL450, MBL 750, MBL900 |
| Type No               | SL AAB 090<br>SL AAH 017, SL AAH 030, SL AAH 045, SL AAH 075, SL AAH 090<br>SL AAM 045, SL AAM 075, SL AAM 090  |
| Series No             | N/A   |
| Manufacturer / Origin | Schmid & Partner Engineering AG<br>Zeughausstrasse 43<br>8004 Zürich<br>Switzerland<br>Phone +41 44 245 9700, Fax +41 44 245 9779, support@speag.com                          |

Use of the substance:

Liquid simulating physical parameters of Brain, Head or Muscle Tissue in the RF range below 2GHz.

**2 Composition / Information on ingredients**

The Item is composed of the following ingredients:

|                        |   |
|------------------------|---|
| H <sub>2</sub> O       | Water, 35 – 55%   |
| Sucrose                | Sugar, white, refined, 40 – 60%   |
| NaCl                   | Sodium Chloride, 0 – 6%   |
| Hydroxyethyl-cellulose | Medium Viscosity (CAS# 9004-62-0), <0.3%  |
| Preventol-D7           | Preservative: aqueous preparation, (CAS# 55965-84-9), containing<br>5-chloro-2-methyl-3(2H)-isothiazolone and 2-methyl-3(2H)-isothiazolone,<br>0.1 – 0.7% |

Relevant for safety; Refer to the respective Safety Data Sheet".

**3 Hazards identification**

|            |       |   |
|------------|-------|---|
| Symbol     | XI    | Irritant                                |
| R-phrases: | 36/38 | Irritating to eyes and skin             |
|            | 43    | May cause sensitization by skin contact |

**4 First aid measures**

|                     |   |
|---------------------|---|
| After skin contact: | Wash off with plenty of water and soap  |
| After eye contact:  | Rinse out with plenty of water with the eyelid held open, call an ophthalmologist                           |
| After swallowing:   | Make victim drink plenty of water, the mouth should be rinsed out several times.<br>Do not induce vomiting. |

**5 Fire-fighting measures**

Not required

**6 Accidental release measures**

Do not allow to enter sewerage system in large quantities, clean up affected area, forward for disposal. The preservative can be destroyed with sodiumhydrogensulfite. Add plenty of water if spilled.

**7 Handling and storage**

Handling: Keep in open container only for minimum required time in order to avoid water evaporation.  
Storage: No special measures against fire or explosion required.



## 8 Exposure controls / personal protection

Eye protection: goggles

Hand protection: e.g. rubber or plastic gloves

Avoid contact with skin and eyes. Wash hands after working with substance.

## 9 Physical and chemical properties

Form: liquid  
Colour: yellowish to light brown, transparent  
Odour: odourless  
pH-Value: neutral, with tendency to lower pH values.  
Boiling point: 100°C  
Density: 1.2 - 1.4 g/cm<sup>3</sup>

## 10 Stability and reactivity

No hazardous decomposition products expected.

## 11 Toxicological information

Irritation to skin and eyes; tendency to corrosive reaction.

In susceptible people, sensitization is possible.

## 12 Ecological information

Do not allow to enter waters, waste water, or soil.

In order to avoid adverse effects on the degradation activity of a sewage plant due to the preservative contained, the preservative concentration must not exceed 3mg/l, which up to 1000 times lower than the amount contained. Considerable amounts of water must therefore be added to amounts spilled into sewers or waste water.

## 13 Disposal considerations

Product: Chemicals must be disposed of in compliance with the respective national regulations.

Packing: Product packing must be disposed of in compliance with respect national regulations.

## 14 Transport information

Not subject to transport regulations.

No UN number is applicable

Avoid temperatures below 0°C. Keep separated from foodstuffs.

## 15 Regulatory information

Labelling according to EC Directives

|            |             |  |
|------------|-------------|--|
| Symbol     | Xn          | Irritant   |
| R-phrases: | 36/38<br>43 | Irritating to eyes and skin<br>May cause sensitization by skin contact |

MAK value for the preservative is 0.05mg/m<sup>3</sup>, corresponding to a concentration of <25mg/m<sup>3</sup> of the final product.

## 16 Other information

\* Safety relevant information bases on:

[1] MSDS for Preventol D7 (Art.Nr.: 329049/08 by Bayer AG, Leverkusen, Germany )

Release date: 11.09.2009

Responsible: FB



Schmid & Partner Engineering AG

**s p e a g**

Zeughausstrasse 43, 8004 Zurich, Switzerland  
 Phone +41 44 245 9700, Fax +41 44 245 9779  
 info@speag.com, http://www.speag.com

**Measurement Certificate / Material Test**

|              |   |
|--------------|---|
| Item Name    | Body Tissue Simulating Liquid (MSL 450) |
| Product No.  | SL AAM 045 BC-A (Charge: 120206-1)      |
| Manufacturer | SPEAG                                   |

**Measurement Method**

TSL dielectric parameters measured using calibrated OCP probe (type DAK).

**Target Parameters**

Target parameters as defined in the IEEE 1528 and IEC 62209 compliance standards.

**Test Condition**

Ambient Condition 22°C ; 30% humidity  
 TSL Temperature 22°C  
 Test Date 8-Feb-12

**Additional Information**

TSL Density 1.226 g/cm<sup>3</sup>  
 TSL Heat-capacity 3.001 kJ/(kg\*K)

**Results**

| f [MHz]    | Measured    |              |             | Target      |             | Diff. to Target [%] |            |
|------------|-------------|--------------|-------------|-------------|-------------|---------------------|------------|
|            | HP-e'       | HP-e''       | sigma       | eps         | sigma       | Δ-eps               | Δ-sigma    |
| 300        | 58.0        | 51.08        | 0.85        | 58.2        | 0.92        | 0.7                 | -7.3       |
| 325        | 58.1        | 48.44        | 0.87        | 58.0        | 0.92        | 0.2                 | -5.5       |
| 350        | 57.5        | 45.81        | 0.89        | 57.7        | 0.93        | -0.3                | -3.8       |
| 363        | 57.3        | 44.81        | 0.90        | 57.6        | 0.93        | -0.5                | -2.9       |
| 375        | 57.1        | 43.81        | 0.91        | 57.5        | 0.93        | -0.6                | -2.0       |
| 386        | 56.9        | 42.81        | 0.92        | 57.3        | 0.93        | -0.6                | -1.2       |
| 400        | 56.6        | 41.82        | 0.93        | 57.2        | 0.93        | -1.0                | -0.3       |
| 413        | 56.4        | 41.08        | 0.94        | 57.1        | 0.93        | -1.1                | 0.7        |
| 425        | 56.2        | 40.34        | 0.95        | 57.0        | 0.94        | -1.3                | 1.6        |
| 438        | 56.0        | 39.60        | 0.95        | 56.8        | 0.94        | -1.5                | 2.6        |
| <b>450</b> | <b>55.8</b> | <b>38.86</b> | <b>0.97</b> | <b>56.7</b> | <b>0.94</b> | <b>-1.6</b>         | <b>3.5</b> |
| 463        | 55.6        | 38.28        | 0.98        | 56.7        | 0.94        | -1.8                | 4.5        |
| 475        | 55.4        | 37.70        | 0.99        | 56.6        | 0.94        | -2.1                | 5.6        |
| 488        | 55.2        | 37.11        | 1.01        | 56.6        | 0.94        | -2.3                | 6.6        |
| 500        | 55.0        | 36.53        | 1.02        | 56.5        | 0.94        | -2.6                | 7.7        |
| 513        | 54.9        | 36.04        | 1.03        | 56.5        | 0.94        | -2.8                | 8.7        |
| 525        | 54.7        | 35.56        | 1.04        | 56.4        | 0.95        | -3.1                | 9.7        |
| 538        | 54.5        | 35.07        | 1.05        | 56.4        | 0.95        | -3.3                | 10.6       |
| 550        | 54.3        | 34.58        | 1.06        | 56.3        | 0.95        | -3.6                | 11.6       |
| 563        | 54.1        | 34.20        | 1.07        | 56.3        | 0.95        | -3.8                | 12.7       |
| 575        | 54.0        | 33.82        | 1.08        | 56.2        | 0.95        | -4.0                | 13.8       |
| 600        | 53.6        | 33.05        | 1.10        | 56.1        | 0.95        | -4.4                | 15.9       |

