



LCIE



Accreditation
N°1-1633
Scope available on
www.cofrac.fr

Template : September 15th, 2023

TEST REPORT

N°: 21019537-796750-C(FILE#6633628)

Version: 03

Subject

Radio spectrum tests according to the standards:
FCC CFR 47 Part 15.247 & ANSI C63.10
RSS-247 & RSS-Gen

Issued to

MICROPORT CRM
4 AVENUE REAUMUR
92140 - CLAMART
FRANCE

Apparatus under test

- ↪ Product
- ↪ Trade mark
- ↪ Manufacturer
- ↪ Family range
- ↪ Model under test
- ↪ Serial number
- ↪ FCCID
- ↪ IC

Defibrillator
MICROPORT CRM
MICROPORT CRM s.r.l
ENERGYA 4LV CRT-D 3744
ENERGYA 4LV CRT-D 3744
Q19JG037 , Q19D503E
YSGCRTD3744
NC

Conclusion

See Test Program chapter

Test date January 16, 2024 to February 01, 2024
Test location LCIE Grenoble
FCC Test site FR0008 - 918017 (MOI)
ISED Test site 6500A (MOI)
Sample receipt date January 15, 2024
Composition of document 50 pages
Document issued on July 01, 2024

Written by :

Akram HAKKARI
Tests operator

Approved by :

Majid MOURZAGH
Technical manager



This document shall not be reproduced, except in full, without the written approval of the LCIE. This document contains results related only to the items tested. It does not imply the conformity of the whole production to the items tested. Unless otherwise specified or rule defined by the test method, the decision of conformity doesn't take into account the uncertainty of measures. This document doesn't anticipate any certification decision. The COFRAC accreditation attests the technical capability of the testing laboratory for the only tests covered by the accreditation. If some tests mentioned in this report are carried out outside the framework of COFRAC accreditation, they are indicated by the symbol

LCIE
Laboratoire Central des Industries Electriques
Une société Bureau Veritas

Z.I Centr'alp
170, Rue de Chatagnon
38430 Moirans
FRANCE

Tél. + 33 4 76 07 36 36
contact@lcie.fr
www.lcie.fr



PUBLICATION HISTORY

Version	Date	Author	Modification
01	March 20, 2024	Akram HAKKARI	Creation of the document
02	March 28, 2024	Akram HAKKARI	Add informations on tables equipment list
03	July 01, 2024	Akram HAKKARI	Correction limi PSD on page

Each new edition of this test report replaces and cancels the previous edition. The control of the old editions of report is under responsibility of client.



L C I E

SUMMARY

1.	TEST PROGRAM	4
2.	EQUIPMENT UNDER TEST: CONFIGURATION (DECLARED BY PROVIDER).....	5
3.	6DB BANDWIDTH	12
4.	MAXIMUM CONDUCTED OUTPUT POWER	16
5.	POWER SPECTRAL DENSITY	21
6.	UNWANTED EMISSIONS IN NON-RESTRICTED FREQUENCY BANDS	25
7.	UNWANTED EMISSIONS IN RESTRICTED FREQUENCY BANDS	30
8.	UNCERTAINTIES CHART	50



1. TEST PROGRAM

References

- 47 CFR Part 15.247 (2023)
- RSS 247 Issue 3
- RSS Gen Issue 5
- KDB 558074 D01 DTS Meas Guidance v05r02 [🔗](#)
- KDB 662911 D01 Multiple Transmitter Output v02r01 [🔗](#)
- ANSI C63.10 (2013)

Radio requirement:

Clause - Test Description		Test result - Comments
6dB Bandwidth	<i>FCC & ISED</i>	PASS
Maximum Conducted Output Power	<i>FCC & ISED</i>	PASS
Power Spectral Density	<i>FCC & ISED</i>	PASS
Unwanted Emissions in Non-Restricted Frequency Bands	<i>FCC & ISED</i>	PASS
Unwanted Emissions in Restricted Frequency Bands	<i>FCC & ISED</i>	PASS
Receiver Radiated Emissions	<i>ISED</i>	PASS(2)
This table is a summary of test report, see conclusion of each clause of this test report for detail.		

(1) Limited program

(2) Testing covered the receive mode, and receiver spurious emissions are considered to be the same as transmitter.

PASS: EUT complies with standard's requirement

FAIL: EUT does not comply with standard's requirement

NA: Not Applicable

NP: Test Not Performed

2. EQUIPMENT UNDER TEST: CONFIGURATION (DECLARED BY PROVIDER)

2.1. HARDWARE IDENTIFICATION (EUT AND AUXILIARIES):

Equipment under test (EUT):

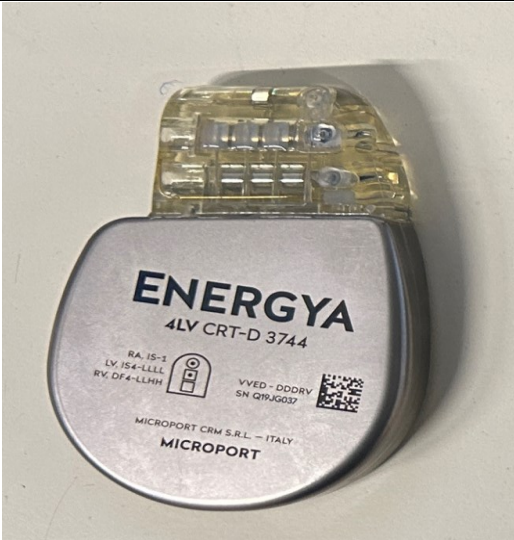
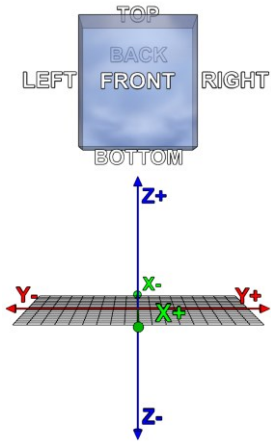
Model under test:	ENERGYA 4LV CRT-D 3744 / Hybrid IS4		
Serial Number:	Q19JG037 , Q19D503E		
			
Dimensions:	5.5cm x 7.6 cm x 0.7cm (Length x Width x Height)		
Type:	Table-Top		

Power supply:

Name	Type	Rating	Reference / Sn	Comments
Supply1	Battery	3.24 VDC	-	-

NC: Not communicated by provider



L C I E

Auxiliary equipment used during test:

Type	Reference	Sn	Comments
Laptop	DELL	-	-
Inductive telemetry Head	CPR3	CM1610029S	-
USB adapter to RS232	Sorin	XA1311038E	-

NC: Not communicated by provider



Equipment information (declaration of provider):

Bluetooth Low Energy:	v4.2
Chipset / RF Module	Nordic nRF52832
Frequency band:	[2400 – 2483.5] MHz
Spectrum Modulation:	DSSS (Tested like it – international agreements)
Number of Channel:	40
Spacing channel:	2MHz
Channel bandwidth:	1MHz
Antenna Type:	Internal
Antenna connector:	Temporary for tests
Antenna requirements §15.203	The transmitter uses an integral antenna and it permanently connected
Transmit chains:	1
Receiver chains	1

CHANNEL PLAN			
Channel	Frequency (MHz)	Channel	Frequency (MHz)
Cmin: 0	2402	Cmid: 20	2442
1	2404	21	2444
2	2406	22	2446
3	2408	23	2448
4	2410	24	2450
5	2412	25	2452
6	2414	26	2454
7	2416	27	2456
8	2418	28	2458
9	2420	29	2460
10	2422	30	2462
11	2424	31	2464
12	2426	32	2466
13	2428	33	2468
14	2430	34	2470
15	2432	35	2472
16	2434	36	2474
17	2436	37	2476
18	2438	38	2478
19	2440	Cmax: 39	2480

DATA RATE			
Available	Data Rate (Mbps)	Modulation Type	Worst Case Modulation
<input type="checkbox"/>	0.25	GFSK (1MHz)	<input type="checkbox"/>
<input checked="" type="checkbox"/>	1	GFSK (1MHz)	<input checked="" type="checkbox"/>
<input type="checkbox"/>	2	GFSK (2MHz)	<input type="checkbox"/>



L C I E

Antenna Characteristic			
Antenna reference	Gain (dBi)	Frequency Band (MHz)	Impedance(Ω)
GA25B	-25.4	[2400 – 2483.5] MHz	50

Hardware information			
Highest internal frequency (PLL, Quartz, Clock, Microprocessor...):	F_{Highest}:	NC	MHz
Firmware (if applicable):	V:	Platinum-V2.8.1	
Software (if applicable):	V:	NC	
Equipment intended:	Mobile		
Type of equipment:	Stand-alone		
Equipment sample:	Production model		
Duty cycle:	Continuous duty		
Operating temperature range:	T_{min} :	32 °C	
	T_{nom} :	37 °C	
	T_{max} :	42 °C	
Operating voltage:	V_{min} (85% V_{nom}):	2.62 VDC	
	V_{nom} :	3.24 VDC	
	V_{max} (115% V_{nom}):	3.3 VDC	

NC: Not communicated by provider

2.2. RUNNING MODE

Test mode	Description of test mode
Test mode 1	Permanent emission with modulation on a fixed channel in the data rate that produced the highest power. Refer to : PLAN 15076C
Test mode 2	Permanent reception Refer to : PLAN 15076C

Test	Running mode
6dB Bandwidth	Test mode 1
Maximum Conducted Output Power	Test mode 1
Power Spectral Density	Test mode 1
Conducted Spurious Emission at the Band Edge	Test mode 1
Unwanted Emissions in Non-Restricted Frequency Bands	Test mode 1
Unwanted Emissions in Restricted Frequency Bands	Test mode 1

(1) Testing covered the receive mode, and receiver spurious emissions are considered to be the same as transmitter.

2.3. EQUIPMENT LABELLING

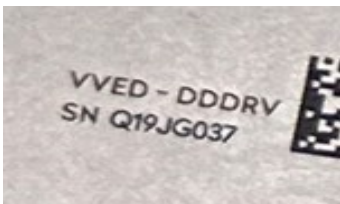
Label

2.4. EQUIPMENT MODIFICATIONS DURING THE TESTS

None



2.5. FIELD STRENGTH CALCULATION

The field strength is calculated by adding the Antenna Factor and Cable Factor, and subtracting the Amplifier Gain (if any) from the measured reading. The basic equation with a sample calculation is as follow:

$$FS = RA + AF + CF - AG$$

Where:

FS = Field Strength

RA = Receiver Amplitude

AF = Antenna Factor

CF = Cable Factor

AG = Amplifier Gain

Example:

Assume a receiver reading of 52.5dB μ V is obtained. The antenna factor of 7.4 and a cable factor of 1.1 are added. The amplifier gain of 29dB is subtracted, giving a field strength of 32 dB μ V/m.

$$FS = 52.5 + 7.4 + 1.1 - 29 = 32 \text{ dB}\mu\text{V/m}$$

The 32 dB μ V/m value can be mathematically converted to its corresponding level in μ V/m.

$$\text{Level in } \mu\text{V/m} = \text{Common Antilogarithm } [(32\text{dB}\mu\text{V/m})/20] = 39.8 \mu\text{V/m.}$$

2.6. TEST DISTANCE EXTRAPOLATION – FCC/ISED

The field strength is extrapolated to the new measurement distance using formula from FCC Part15.31 (f) and §6.5-6.6 RSS-GEN:

Below 30MHz,

$$FS_{\text{limit}} = FS_{\text{max}} - 40 \log \left(\frac{d_{\text{limit}}}{d_{\text{measure}}} \right)$$

Above 30MHz,

$$FS_{\text{limit}} = FS_{\text{max}} - 20 \log \left(\frac{d_{\text{limit}}}{d_{\text{measure}}} \right)$$

Where:

FS_{limit} is the calculation of field strength at the limit distance, expressed in dB μ V/m

FS_{max} is the measured field strength, expressed in dB μ V/m

d_{measure} is the distance of the measurement point from the EUT

d_{limit} is the reference limit distance

2.7. CALIBRATION DATE

The calibration intervals are extended at 12+2 months. This extended interval is based on the fact that there is sufficient calibration data to statistically establish a trend or based on experience of use of the test equipment to assure good measurement results for a longer period.

2.8. METHOD TO DETERMINATE THE SPURIOUS RADIATED EMISSION

The Normalized Site Attenuation (NSA) is added to the maximum values observed during the azimuth search in order to obtain the spurious radiated emission. For spurious above -6dB from the limit found with the NSA, the Substitution Method is applied.



The substitution antenna replaces the equipment under test (EUT) for Effective Radiated Power (ERP) or Effective Isotropically Radiated Power (EIRP) measurement following the standard. Power is measured for a high level and calculated for the same level of radiated field strength obtained on the measuring antenna and EUT.

3. 6dB BANDWIDTH

3.1. TEST CONDITIONS

Date of test : January 24, 2024
 Test performed by : Akram HAKKARI
 Relative humidity (%) : 33
 Ambient temperature (°C) : 21

3.2. TEST SETUP

The Equipment Under Test is installed in an anechoic chamber.
 Measurement is performed with a spectrum analyzer in conducted method.

The EUT is turned ON, the center frequency of the spectrum analyzer is set to the fundamental frequency. The captured power is measured and recorded; the measurement is repeated until all frequencies required were complete.

Test Procedure:

KDB 558074 D01 DTS Meas Guidance v05r02 § 8.2

- Set resolution bandwidth (RBW) = 100kHz.
- Set the video bandwidth (VBW) $\geq 3 \times$ RBW.
- Detector = Peak.
- Trace mode = max hold.
- Sweep = auto couple.
- Allow the trace to stabilize.
- Measure the maximum width of the emission that is constrained by the frequencies associated with the two outermost amplitude points (upper and lower) that are attenuated by 6 dB relative to the maximum level measured in the fundamental emission. Compare the resultant bandwidth with the RBW setting of the analyzer.

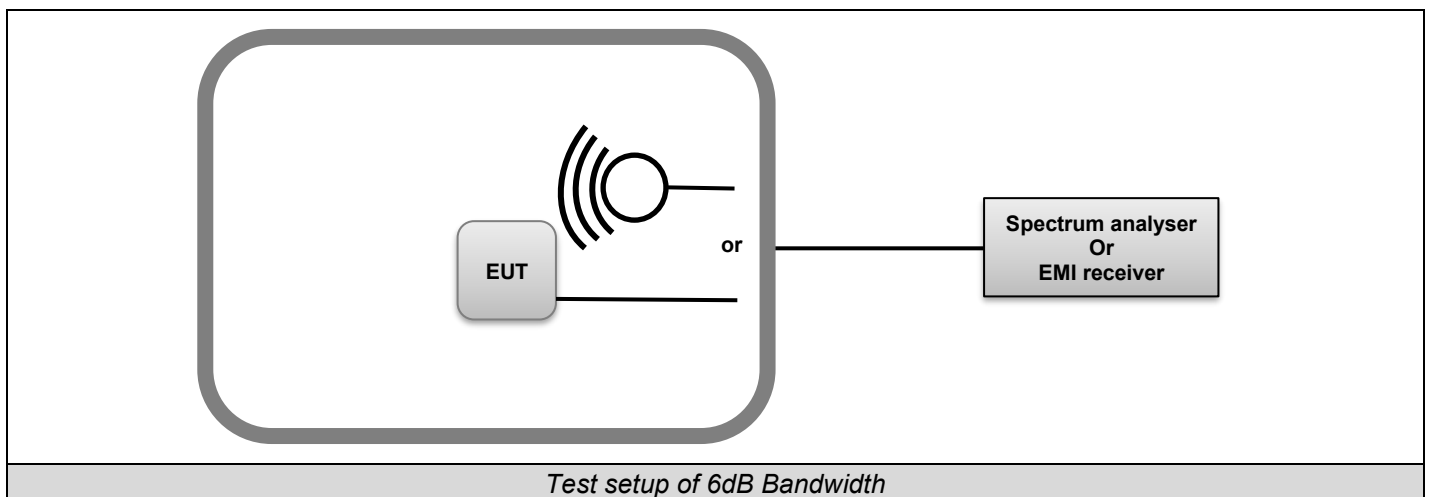

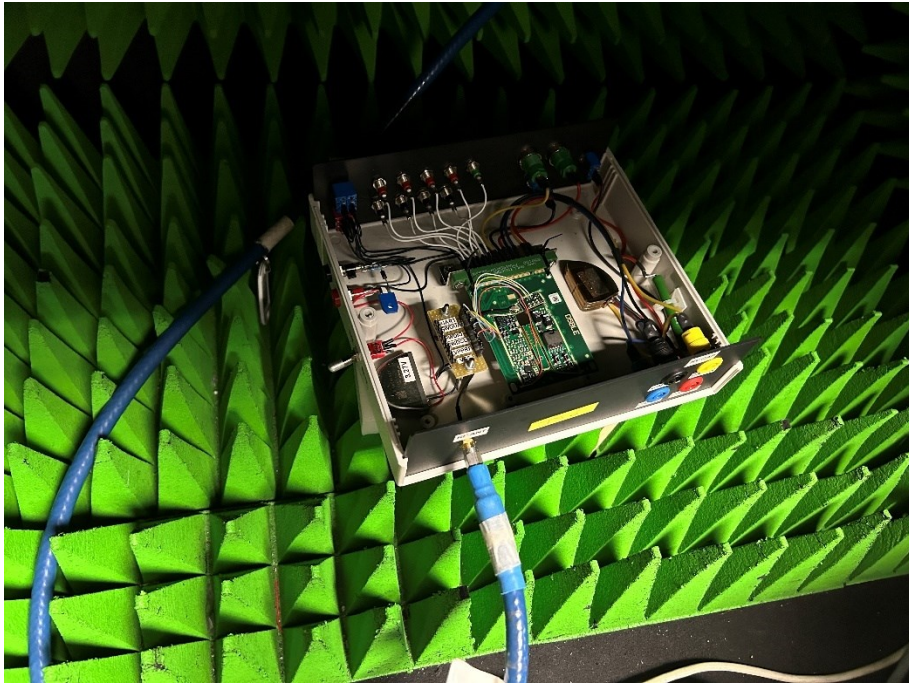

Photo of 6dB bandwidth

3.3. LIMIT

Frequency range	6dB bandwidth
902-928MHz 2400MHz to 2483.5MHz 5725-5850 MHz	≥500kHz



3.4. TEST EQUIPMENT LIST

TEST EQUIPMENT USED					
Description	Manufacturer	Model	Identifier	Cal_Date	Cal_Due
Attenuator 10dB	AEROFLEX	_	A7122267	10/23	10/25
DC Power Supply	RS PRO	RS3005P	A7042314	N/A	N/A
Multimeter - CEM	FLUKE	87	A1240251	10/23	10/25
Emission Cable (SMA 1m)	TELEDYNE	26GHz	A5329874	08/22	08/25
Full Anechoic Room	SIEPEL	_	D3044024	N/A	N/A
SMA 1.5m	SUCOFLEX	18GHz	A5329864	10/23	10/24
Spectrum analyzer	ROHDE & SCHWARZ	FSV 40	A4060059	11/21	03/24*
Thermo-hygrometer	TESTO	608-H1	B4204120	03/23	03/25

N/A: Not applicable

*: Under derogation

3.5. DIVERGENCE, ADDITION OR SUPPRESSION ON THE TEST SPECIFICATION

None



3.6. RESULTS

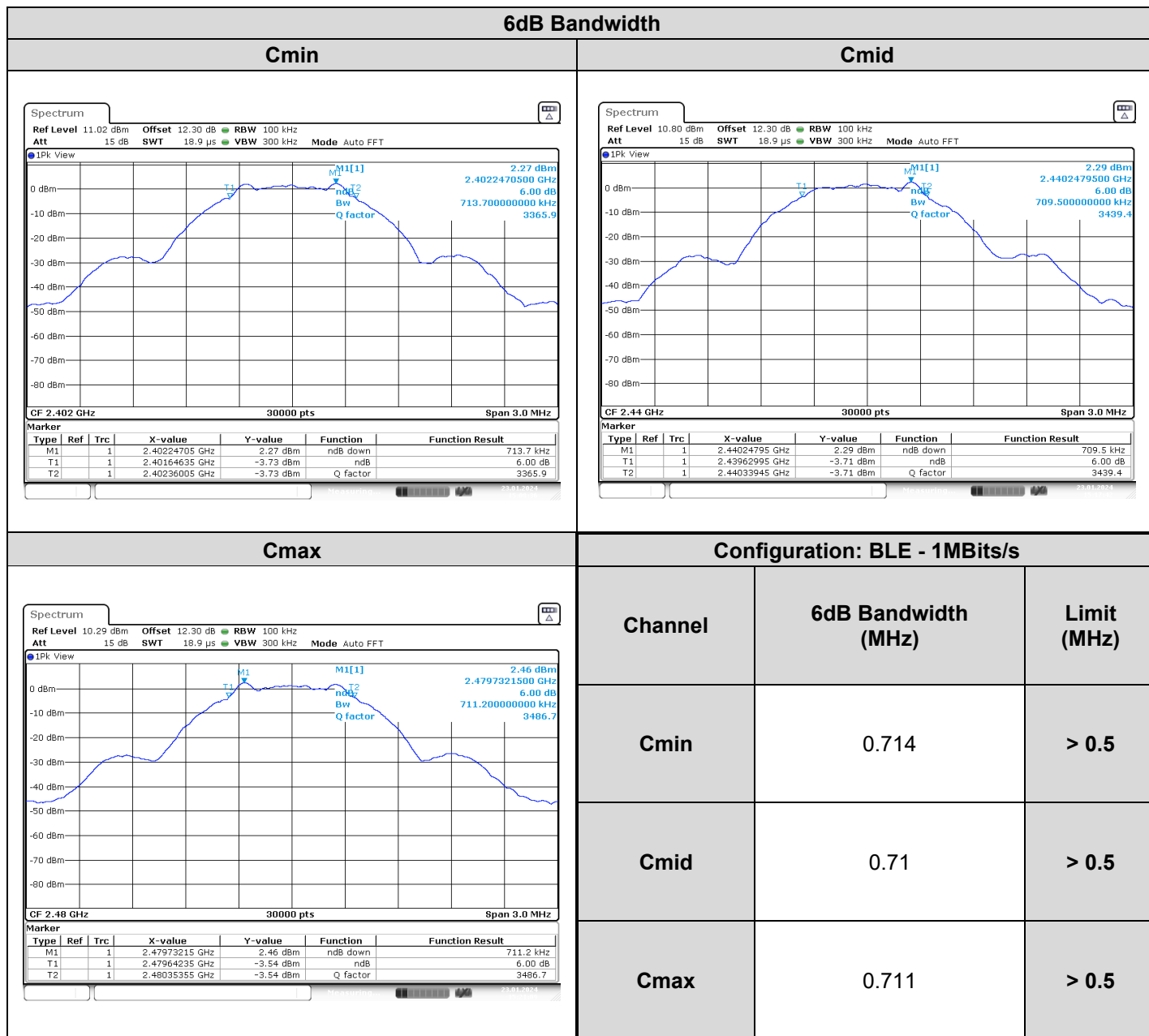

3.7. CONCLUSION

6dB Bandwidth measurement performed on the sample of the product **ENERGYA 4LV CRT-D 3744**, Sn: **Q19JG037** , **Q19D503E**, in configuration and description presented in this test report, show levels compliant to the **47 CFR PART 15.247 & RSS 247** limits.



4. MAXIMUM CONDUCTED OUTPUT POWER

4.1. TEST CONDITIONS

Date of test : January 24, 2024
Test performed by : Akram HAKKARI
Relative humidity (%) : 33
Ambient temperature (°C) : 21

4.2. TEST SETUP

The Equipment Under Test is installed in an anechoic chamber.
Measurement is performed with a spectrum analyzer in conducted method.

The EUT is turned ON, the center frequency of the spectrum analyzer is set to the fundamental frequency. The captured power is measured and recorded; the measurement is repeated until all frequencies required were complete.

Test Procedure used: KDB 558074 D01 DTS Meas Guidance v05r02 § 8.3.1.1
KDB 558074 D01 DTS Meas Guidance v05r02 § 8.3.1.1

This procedure shall be used when the measurement instrument has available a resolution bandwidth that is greater than the DTS bandwidth.

- Set the RBW \geq DTS bandwidth.
- Set VBW \geq 3 x RBW.
- Set span \geq 3 x RBW
- Sweep time = auto couple.
- Detector = peak.
- Trace mode = max hold.
- Allow trace to fully stabilize.
- Use peak marker function to determine the peak amplitude level.

KDB 558074 D01 DTS Meas Guidance v05r02 § 8.3.1.2

This procedure may be used when the maximum available RBW of the measurement instrument is less than the DTS bandwidth.

- Set the RBW = 1 MHz.
- Set the VBW \geq 3 x RBW
- Set the span \geq 1.5 x DTS bandwidth.
- Detector = peak.
- Sweep time = auto couple.
- Trace mode = max hold.
- Allow trace to fully stabilize.
- Use the instrument's band/channel power measurement function with the band limits set equal to the DTS bandwidth edges

KDB 558074 D01 DTS Meas Guidance v05r02 § 8.3.2.2(Method AVGSA-1)

Subclause 11.9.2.2 of ANSI C63.10 is applicable, Method AVGSA-1 uses trace averaging with the EUT transmitting at full power throughout each sweep.

- a) Set span to at least 1.5 times the OBW.
- b) Set RBW = 1% to 5% of the OBW, not to exceed 1 MHz.
- c) Set VBW \geq [3 x RBW].
- d) Number of points in sweep \geq [2 x span / RBW]. (This gives bin-to-bin spacing \leq RBW / 2, so that narrowband signals are not lost between frequency bins.)
- e) Sweep time = auto.

- o f) Detector = RMS (i.e., power averaging), if available. Otherwise, use sample detector mode.
- o g) If transmit duty cycle < 98%, use a sweep trigger with the level set to enable triggering only on full power pulses. The transmitter shall operate at the maximum power control level for the entire duration of every sweep. If the EUT transmits continuously (i.e., with no OFF intervals) or at duty cycle $\geq 98\%$, and if each transmission is entirely at the maximum power control level, then the trigger shall be set to “free run.”
- o h) Trace average at least 100 traces in power averaging (rms) mode.
- o i) Compute power by integrating the spectrum across the OBW of the signal using the instrument’s band power measurement function, with band limits set equal to the OBW band edges. If the instrument does not have a band power function, sum the spectrum levels (in power units) at intervals equal to the RBW extending across the entire OBW of the spectrum.

KDB 558074 D01 DTS Meas Guidance v05r02 § 8.3.2.2(Method AVGSA-2)

Subclause 11.9.2.2 of ANSI C63.10 is applicable.

Method AVGSA-2 uses trace averaging across ON and OFF times of the EUT transmissions, followed by duty cycle correction. The procedure for this method is as follows:

- o a) Measure the duty cycle D of the transmitter output signal as described in 11.6.
- o b) Set span to at least 1.5 times the OBW.
- o c) Set RBW = 1% to 5% of the OBW, not to exceed 1 MHz.
- o d) Set VBW $\geq [3 \times \text{RBW}]$.
- o e) Number of points in sweep $\geq [2 \times \text{span} / \text{RBW}]$. (This gives bin-to-bin spacing $\leq \text{RBW} / 2$, so that narrowband signals are not lost between frequency bins.)
- o f) Sweep time = auto.
- o g) Detector = RMS (i.e., power averaging), if available. Otherwise, use the sample detector mode.
- o h) Do not use sweep triggering. Allow the sweep to “free run.”
- o i) Trace average at least 100 traces in power averaging (rms) mode; however, the number of traces to be averaged shall be increased above 100 as needed such that the average accurately represents the true average over the ON and OFF periods of the transmitter.
- o j) Compute power by integrating the spectrum across the OBW of the signal using the instrument’s band power measurement function with band limits set equal to the OBW band edges. If the instrument does not have a band power function, then sum the spectrum levels (in power units) at intervals equal to the RBW extending across the entire OBW of the spectrum.
- o k) Add $[10 \log (1 / D)]$, where D is the duty cycle, to the measured power to compute the average power during the actual transmission times (because the measurement represents an average over both the ON and OFF times of the transmission). For example, add $[10 \log (1/0.25)] = 6 \text{ dB}$ if the duty cycle is 25%.

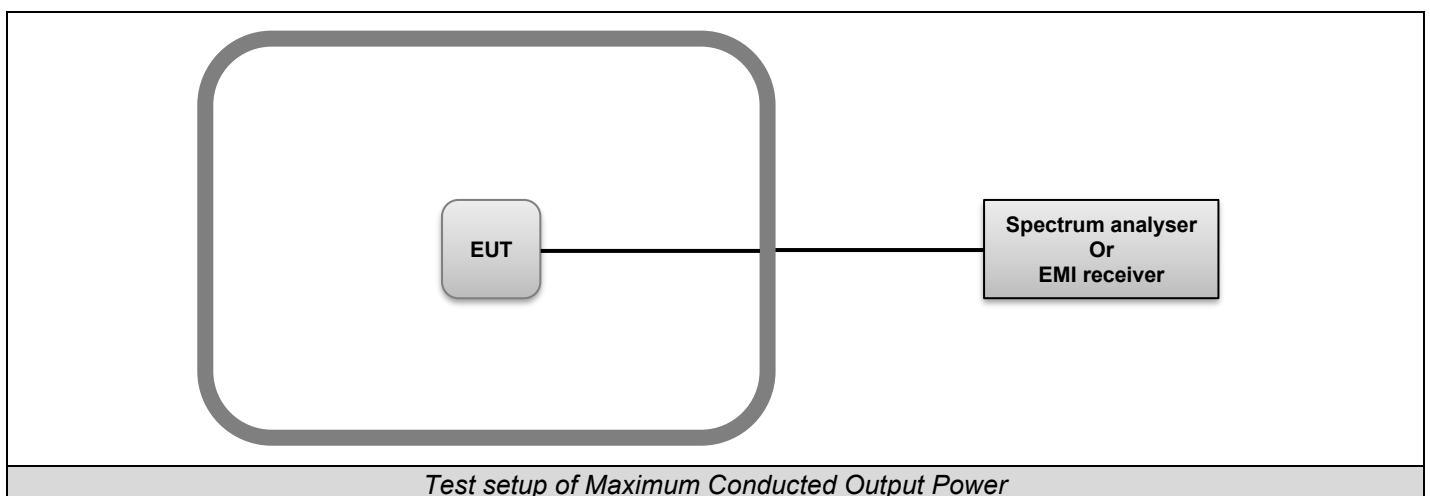



L C I E

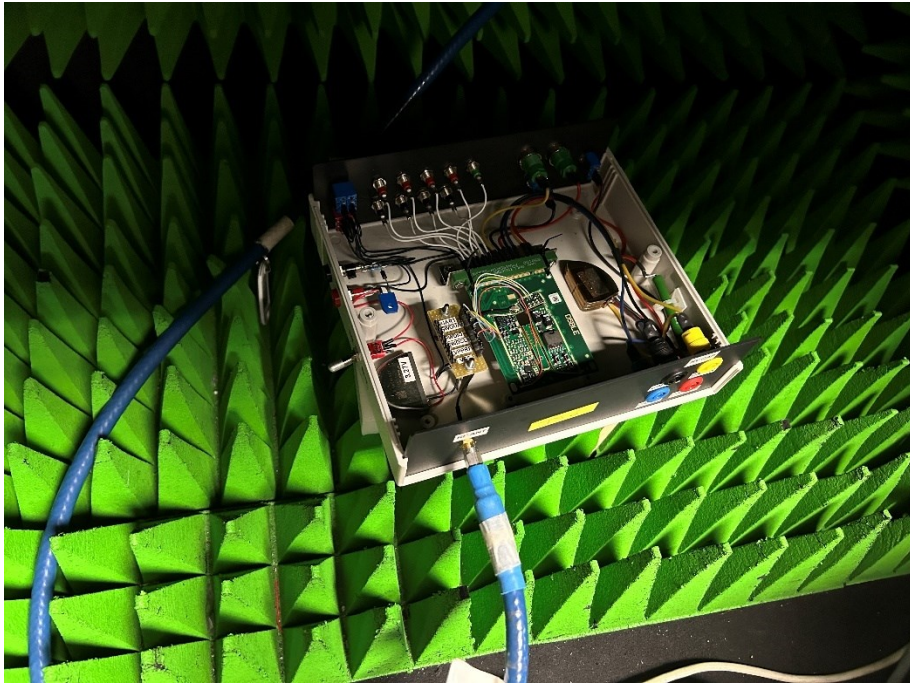

Photo of Maximum Conducted Output Power



4.3. LIMIT

Frequency range	Maximum Conducted Output Power
902-928MHz 2400MHz to 2483.5MHz 5725-5850 MHz	≤30dBm*

*Remark: Limits are reduced by G-6dBi if Overall Antenna Gain above 6dBi

4.4. TEST EQUIPMENT LIST

TEST EQUIPMENT USED					
Description	Manufacturer	Model	Identifier	Cal_Date	Cal_Due
Attenuator 10dB	AEROFLEX	_	A7122267	10/23	10/25
DC Power Supply	RS PRO	RS3005P	A7042314	N/A	N/A
Multimeter - CEM	FLUKE	87	A1240251	10/23	10/25
Emission Cable (SMA 1m)	TELEDYNE	26GHz	A5329874	08/22	08/25
Full Anechoic Room	SIEPEL	_	D3044024	N/A	N/A
SMA 1.5m	SUCOFLEX	18GHz	A5329864	10/23	10/24
Spectrum analyzer	ROHDE & SCHWARZ	FSV 40	A4060059	11/21	03/24*
Thermo-hygrometer	TESTO	608-H1	B4204120	03/23	03/25

N/A: Not applicable

*: Under derogation

4.5. DIVERGENCE, ADDITION OR SUPPRESSION ON THE TEST SPECIFICATION

None

4.6. RESULTS

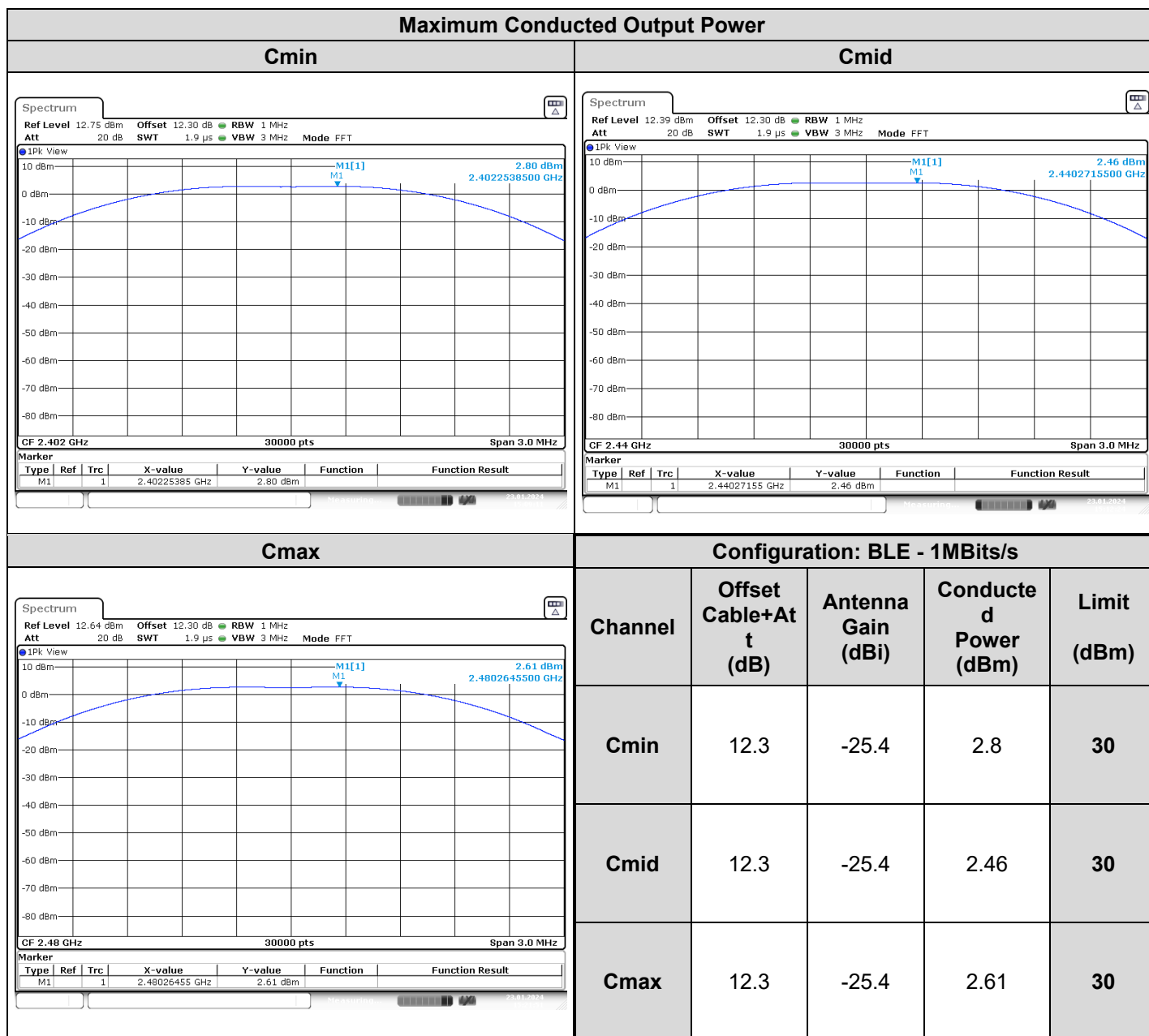

4.7. CONCLUSION

Maximum Output Conducted Power measurement performed on the sample of the product **ENERGYA 4LV CRT-D 3744**, Sn: **Q19JG037**, **Q19D503E**, in configuration and description presented in this test report, show levels **compliant** to the **47 CFR PART 15.247 & RSS 247** limits.



5. POWER SPECTRAL DENSITY

5.1. TEST CONDITIONS

Date of test : January 25, 2024
Test performed by : Akram HAKKARI
Relative humidity (%) : 33
Ambient temperature (°C) : 22

5.2. TEST SETUP

The Equipment Under Test is installed in an anechoic chamber.
Measurement is performed with a spectrum analyzer in conducted method.

The EUT is turned ON, the center frequency of the spectrum analyzer is set to the fundamental frequency. The captured power is measured and recorded; the measurement is repeated until all frequencies required were complete.

Test Procedure used: KDB 558074 D01 DTS Meas Guidance v05r02 § 8.4 (Method PKPSD)
KDB 558074 D01 DTS Meas Guidance v05r02 § 8.4 (Method PKPSD)

Subclause 11.10 of ANSI C63.10 is applicable

- Set analyzer center frequency to DTS channel center frequency.
- Set the span to 1.5 times the DTS bandwidth.
- Set the RBW to: 3 kHz.
- Set the VBW $\geq 3 \times$ RBW.
- Detector = peak.
- Sweep time = auto couple.
- Trace mode = max hold.
- Allow trace to fully stabilize.
- Use the peak marker function to determine the maximum amplitude level within the RBW.
- If measured value exceeds limit, reduce RBW (no less than 3 kHz) and repeat.

KDB 558074 D01 DTS Meas Guidance v05r02 § 8.4 (Method AVGPS-1)

Subclause 11.10 of ANSI C63.10 is applicable

Method AVGPS-1 uses trace averaging with EUT transmitting at full power throughout each sweep. The following procedure may be used when the maximum (average) conducted output power was used to determine compliance to the fundamental output power limit. This is the baseline method for determining the maximum (average) conducted PSD level. If the instrument has a power averaging (rms) detector, then it must be used; otherwise, use the sample detector. The EUT must be configured to transmit continuously ($D \geq 98\%$), or else sweep triggering/signal gating must be implemented to ensure that measurements are made only when the EUT is transmitting at its maximum power control level (no transmitter OFF time to be considered):

- a) Set instrument center frequency to DTS channel center frequency.
- b) Set span to at least 1.5 times the OBW.
- c) Set RBW to: $3 \text{ kHz} \leq \text{RBW} \leq 100 \text{ kHz}$.
- d) Set VBW $\geq [3 \times \text{RBW}]$.
- e) Detector = power averaging (rms) or sample detector (when rms not available).
- f) Ensure that the number of measurement points in the sweep $\geq [2 \times \text{span} / \text{RBW}]$.
- g) Sweep time = auto couple.
- h) Employ trace averaging (rms) mode over a minimum of 100 traces.
- i) Use the peak marker function to determine the maximum amplitude level.
- j) If the measured value exceeds requirement, then reduce RBW (but no less than 3 kHz) and repeat (note that this may require zooming in on the emission of interest and reducing the span to meet the minimum measurement point requirement as the RBW is reduced).

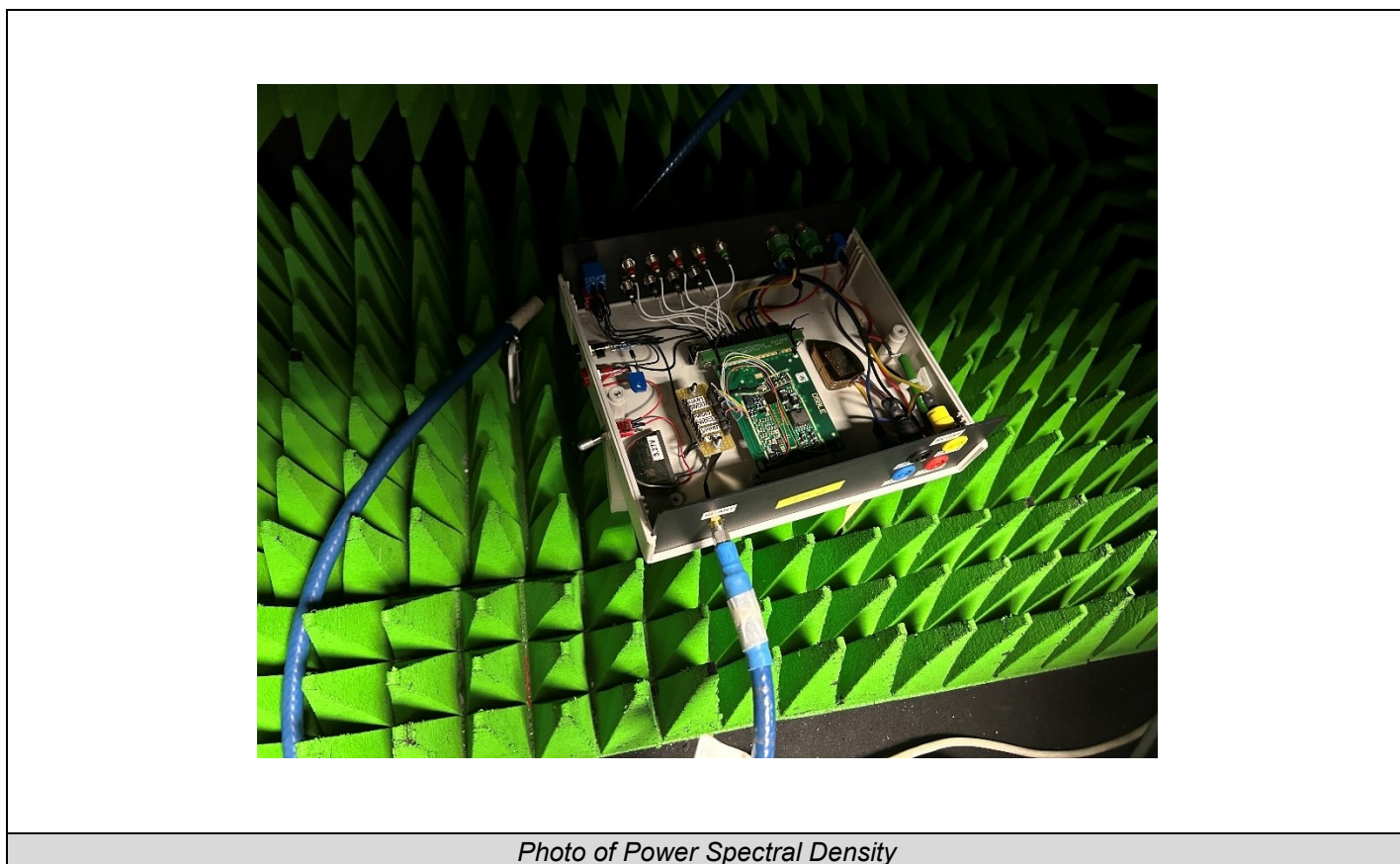
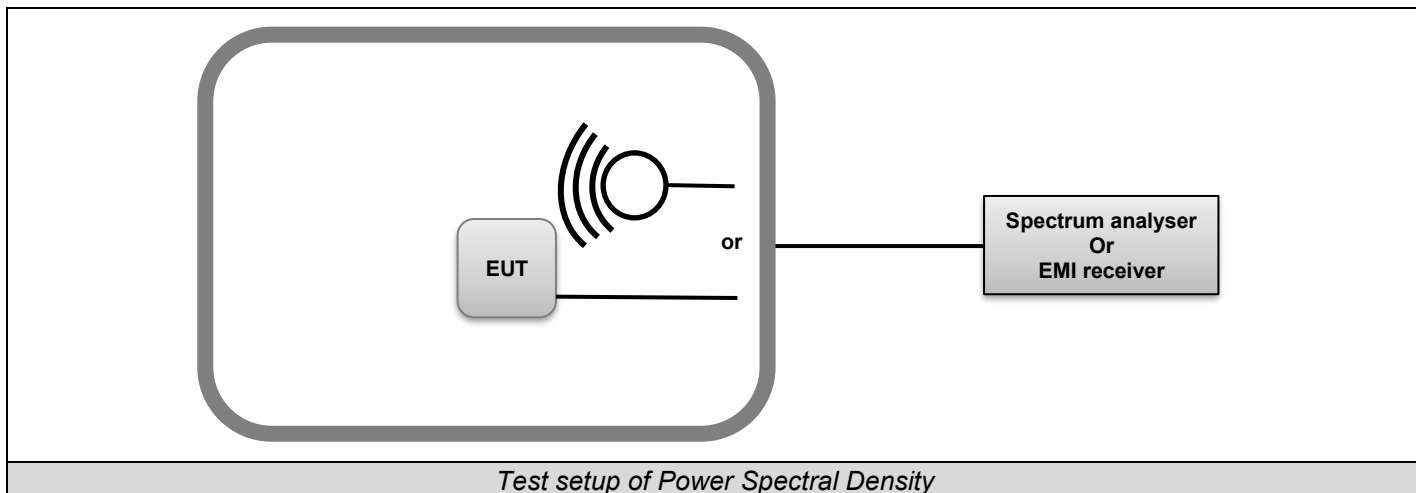



5.3. LIMIT

Frequency range	Power Spectral Density
902-928MHz 2400MHz to 2483.5MHz 5725-5850 MHz	≤8dBm / 3kHz *

*Remark: Limits are reduced by G-6dBi if Overall Antenna Gain above 6dBi

5.4. TEST EQUIPMENT LIST

TEST EQUIPMENT USED					
Description	Manufacturer	Model	Identifier	Cal_Date	Cal_Due
Attenuator 10dB	AEROFLEX	_	A7122267	10/23	10/25
DC Power Supply	RS PRO	RS3005P	A7042314	N/A	N/A
Multimeter - CEM	FLUKE	87	A1240251	10/23	10/25
Emission Cable (SMA 1m)	TELEDYNE	26GHz	A5329874	08/22	08/25
Full Anechoic Room	SIEPEL	_	D3044024	N/A	N/A
SMA 1.5m	SUCOFLEX	18GHz	A5329864	10/23	10/24
Spectrum analyzer	ROHDE & SCHWARZ	FSV 40	A4060059	11/21	03/24*
Thermo-hygrometer	TESTO	608-H1	B4204120	03/23	03/25

N/A: Not applicable

*: Under derogation

5.5. DIVERGENCE, ADDITION OR SUPPRESSION ON THE TEST SPECIFICATION

None

5.6. RESULTS

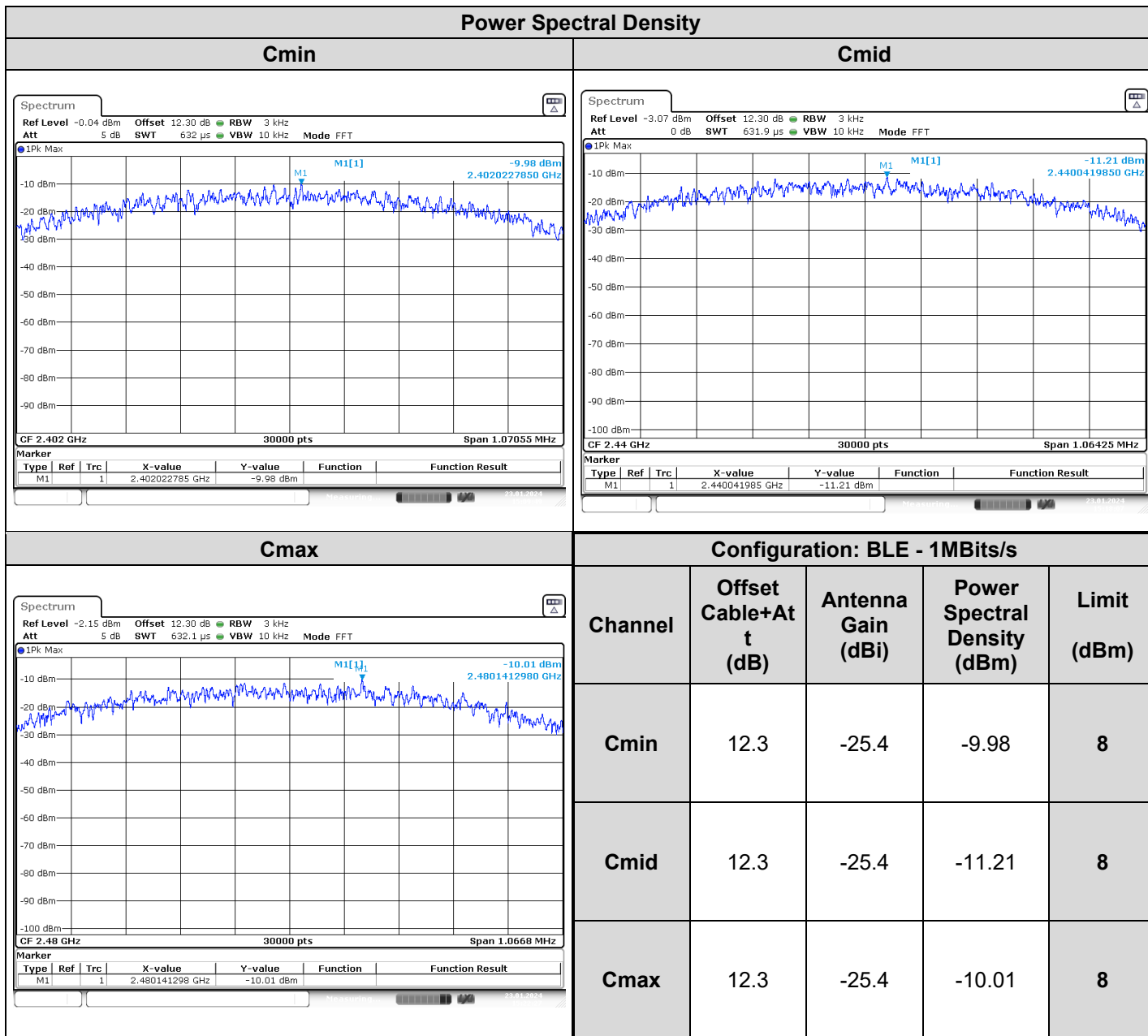

5.7. CONCLUSION

Power Spectral Density measurement performed on the sample of the product **ENERGYA 4LV CRT-D 3744**, Sn: **Q19JG037** , **Q19D503E**, in configuration and description presented in this test report, show levels **compliant** to the **47 CFR PART 15.247 & RSS 247** limits.

6. UNWANTED EMISSIONS IN NON-RESTRICTED FREQUENCY BANDS

6.1. TEST CONDITIONS

Date of test : January 23, 2024
 Test performed by : Akram HAKKARI
 Relative humidity (%) : 32
 Ambient temperature (°C) : 22

6.2. TEST SETUP

The Equipment Under Test is installed in an anechoic chamber.
 Measurement is performed with a spectrum analyzer in conducted method.

The EUT is turned ON, the captured power is measured and recorded; the measurement is repeated until all frequencies required were complete.

Test Procedure:
KDB 558074 D01 DTS Meas Guidance v05r02 § 8.5

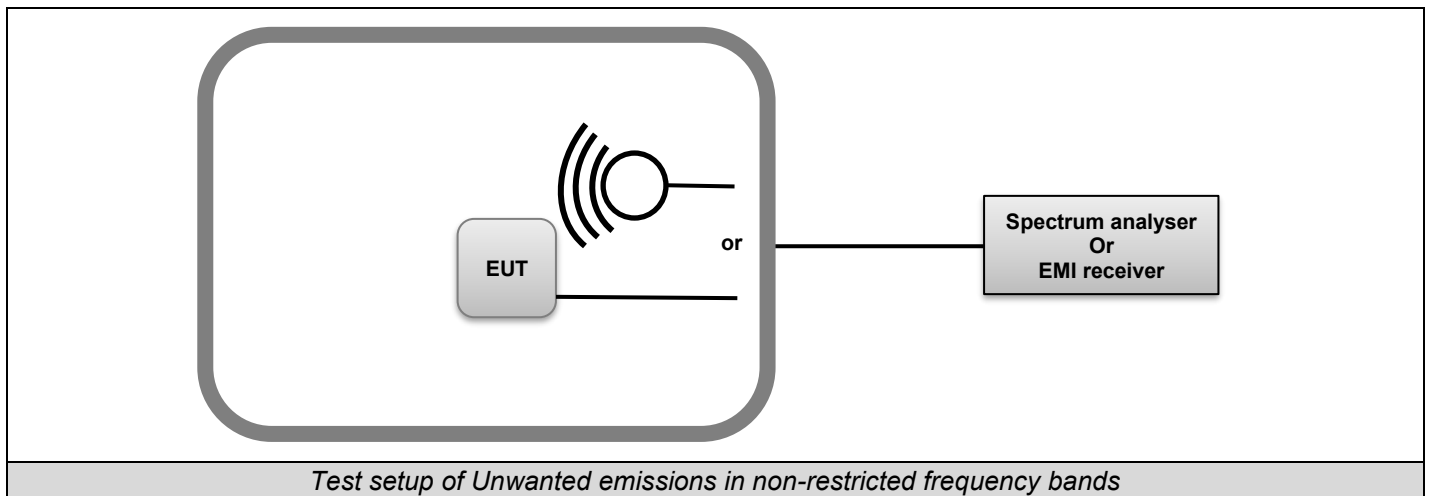

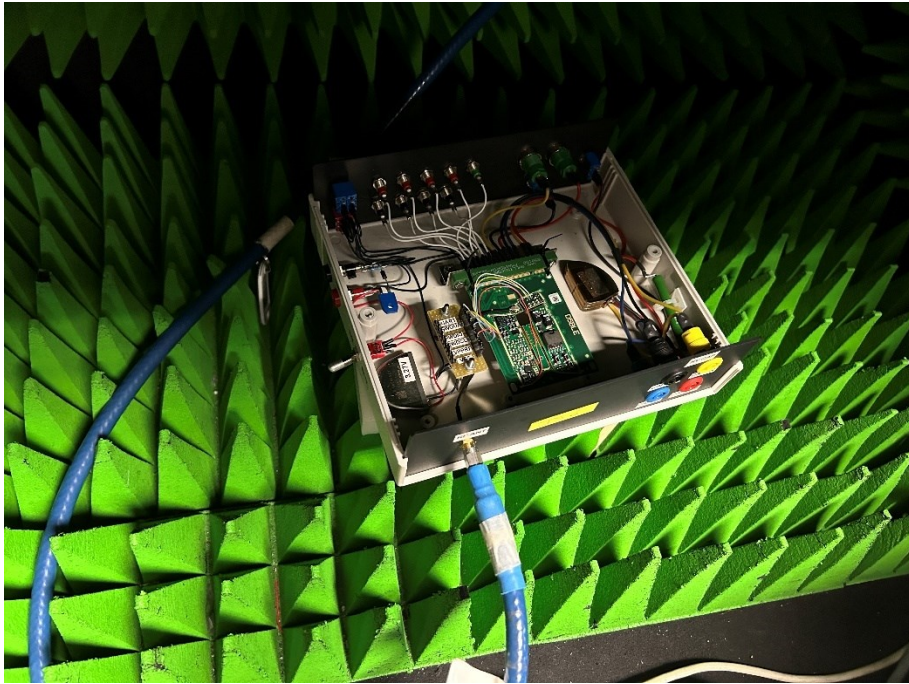

Photo of Unwanted emissions in non-restricted frequency bands



6.3. LIMIT

All Spurious Emissions must be at least 20dB below the Fundamental Radiator Level at the Band Edge of operating frequency band and in non-restricted bands.

6.4. TEST EQUIPMENT LIST

TEST EQUIPMENT USED					
Description	Manufacturer	Model	Identifier	Cal_Date	Cal_Due
Attenuator 10dB	AEROFLEX	_	A7122267	10/23	10/25
DC Power Supply	RS PRO	RS3005P	A7042314	N/A	N/A
Multimeter - CEM	FLUKE	87	A1240251	10/23	10/25
Emission Cable (SMA 1m)	TELEDYNE	26GHz	A5329874	08/22	08/25
Full Anechoic Room	SIEPEL	_	D3044024	N/A	N/A
SMA 1.5m	SUCOFLEX	18GHz	A5329864	10/23	10/24
Spectrum analyzer	ROHDE & SCHWARZ	FSV 40	A4060059	11/21	03/24*
Thermo-hygrometer	TESTO	608-H1	B4204120	03/23	03/25

N/A: Not applicable

*: Under derogation

6.5. DIVERGENCE, ADDITION OR SUPPRESSION ON THE TEST SPECIFICATION

None



6.6. RESULTS

6.6.1. At the band edge

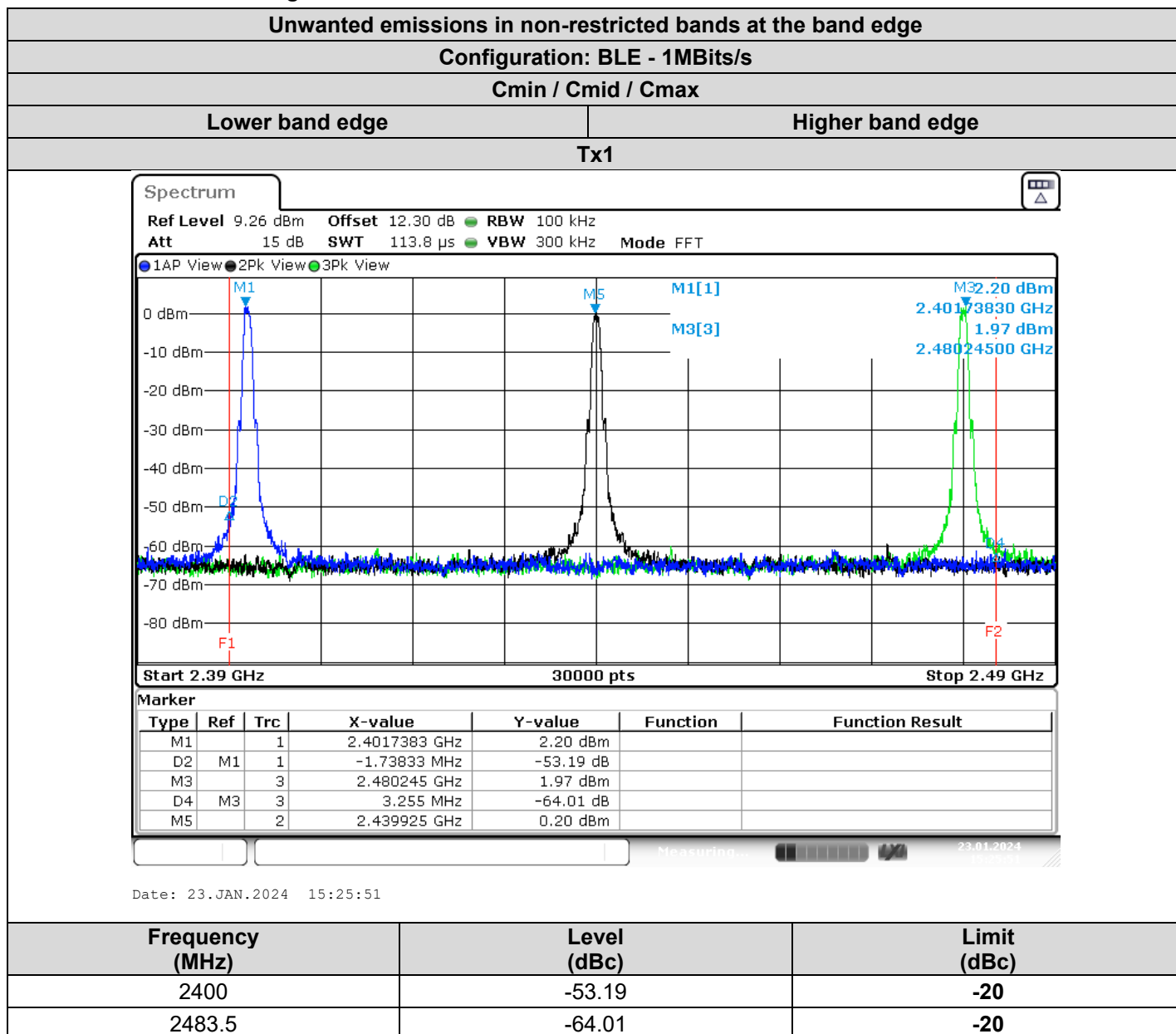

6.6.2. Non restricted frequency bands

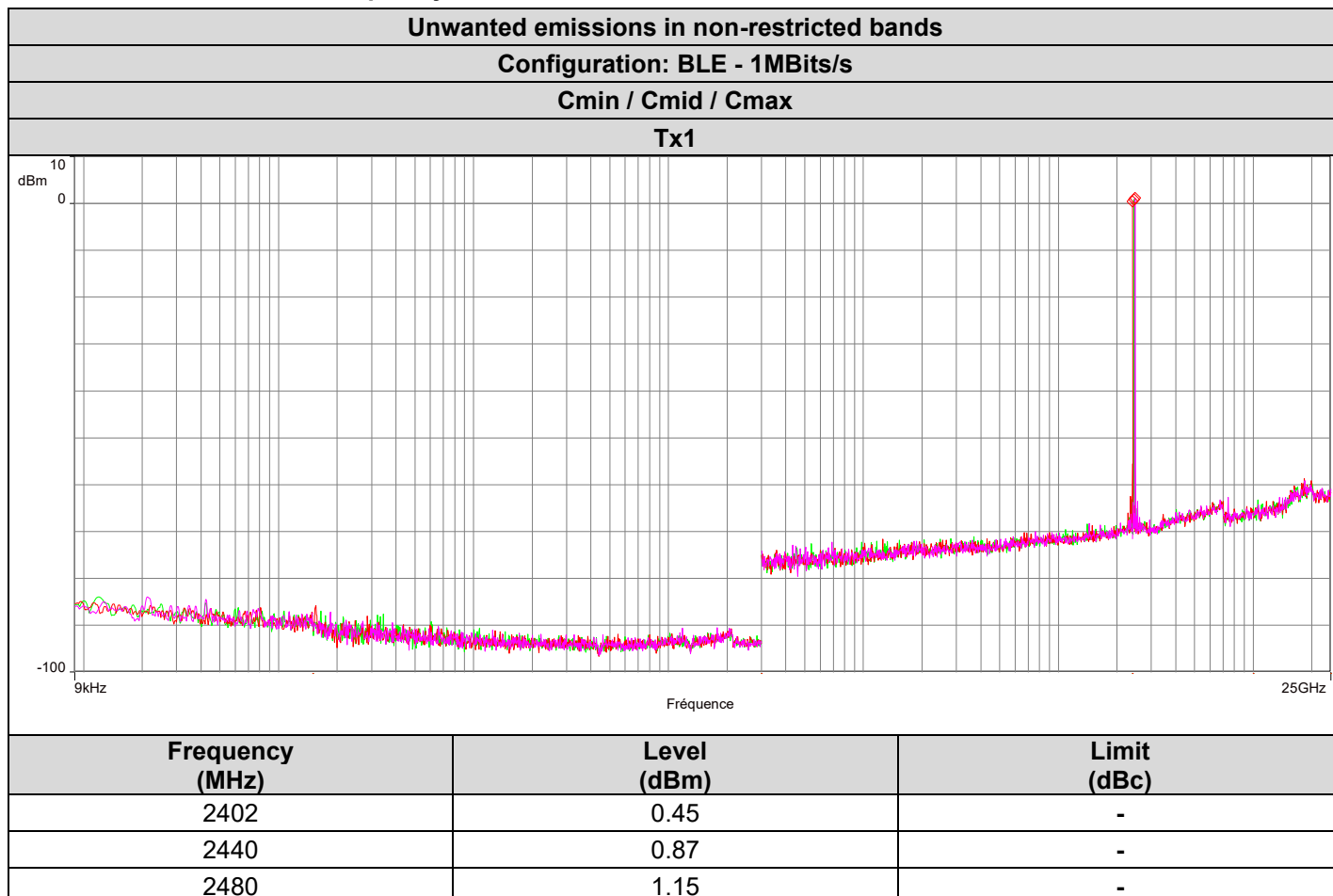

6.7. CONCLUSION

Unwanted emissions in non-restricted bands and at the band edge measurement performed on the sample of the product **ENERGYA 4LV CRT-D 3744**, Sn: **Q19JG037** , **Q19D503E**, in configuration and description presented in this test report, show levels **compliant** to the **47 CFR PART 15.247 & RSS 247** limits.



7. UNWANTED EMISSIONS IN RESTRICTED FREQUENCY BANDS

7.1. TEST CONDITIONS

Date of test : January 24, 2024
 Test performed by : Akram HAKKARI
 Relative humidity (%) : 33
 Ambient temperature (°C) : 22

7.2. TEST SETUP

Test procedure:
 ANSI C63.10 & FCC Part 15 subpart C

Following frequency ranges, test setup parameters are different and specified in this table:

Frequency range:	9kHz to 30MHz	
Test:	Pre-Characterization	Qualification
Antenna Polarization:	Parallel, Perpendicular and Ground parallel	
Antenna Height:	1m	1m
Antenna Type:	Loop	
RBW Filter:	200Hz below 150kHz / 9kHz above 150kHz	
Maximization:	Turntable rotation of 360 degrees range	
EUT height:	1.5m	1.0m
Test site:	Full Anechoic Chamber	Open Aera Test Site
Distance EUT - Antenna:	3m	10m
Detector:	Peak	QPeak

Frequency range:	30MHz to 1GHz	
Test:	Pre-Characterization	Qualification
Antenna Polarization:	Horizontal and Vertical	
Antenna Height:	Centered on EUT (§6.6.5 ANSI C63-10)	Varied from 1m to 4m
Antenna Type:	Bi-Log	
RBW Filter:	120kHz	
Maximization:	Turntable rotation of 360 degrees range	
EUT height:	1.5m	0.8m
Test site:	Full Anechoic Chamber	Open Aera Test Site
Distance EUT - Antenna:	3m	3m
Detector:	Peak	QPeak



Frequency range:	1GHz to 14GHz	
Test:	Pre-Characterization	Qualification
Antenna Polarization:	Horizontal and Vertical	
Antenna Height:	Centered on EUT (§6.6.5 ANSI C63-10)	Centered on EUT (§6.6.5 ANSI C63-10)
Antenna Type:	Horn	
RBW Filter:	1MHz	
Maximization:	Turntable rotation of 360 degrees range	
EUT height:	1.5m	1.5m
Test site:	Full Anechoic Chamber	Full Anechoic Chamber
Distance EUT - Antenna:	3m	3m
Detector:	Peak & Average	Peak & Average

Frequency range:	14GHz to 25GHz	
Test:	Pre-Characterization	Qualification
Antenna Polarization:	Horizontal and Vertical	
Antenna Height:	Centered on EUT (§6.6.5 ANSI C63-10)	Centered on EUT (§6.6.5 ANSI C63-10)
Antenna Type:	Horn	
RBW Filter:	1MHz	
Maximization:	Turntable rotation of 360 degrees range	
EUT height:	1.5m	1.5m
Test site:	Full Anechoic Chamber	Full Anechoic Chamber
Distance EUT - Antenna:	1m	1m
Detector:	Peak & Average	Peak & Average



L C I E

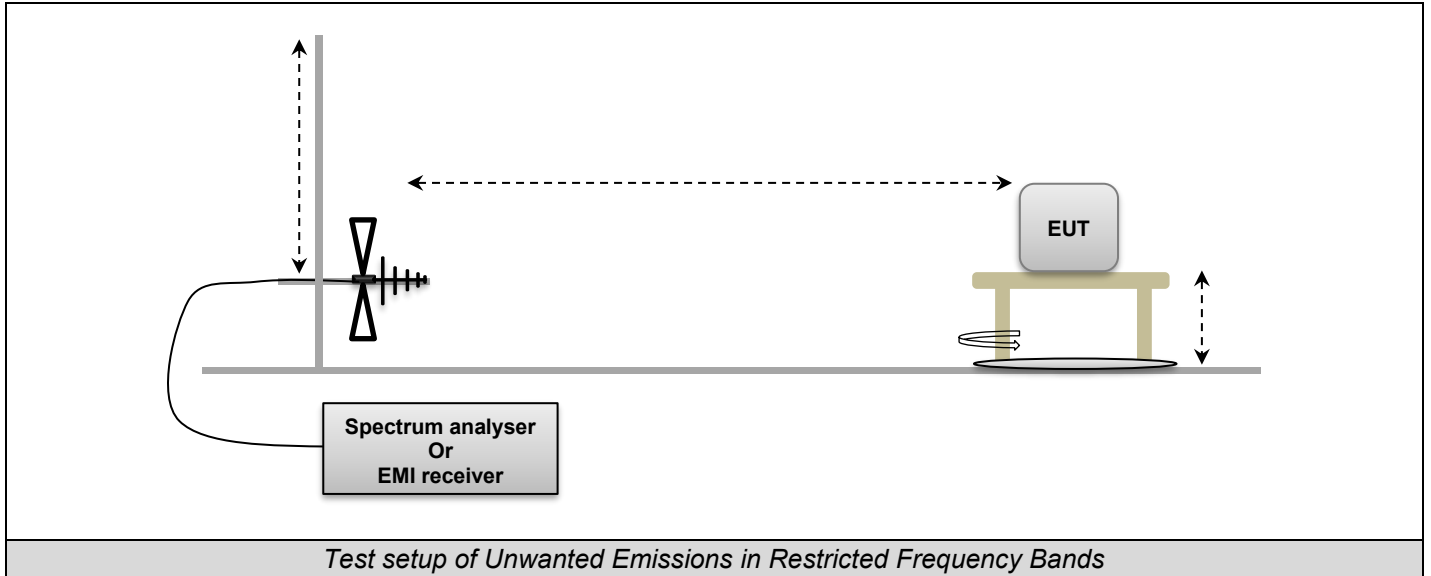



L C I E



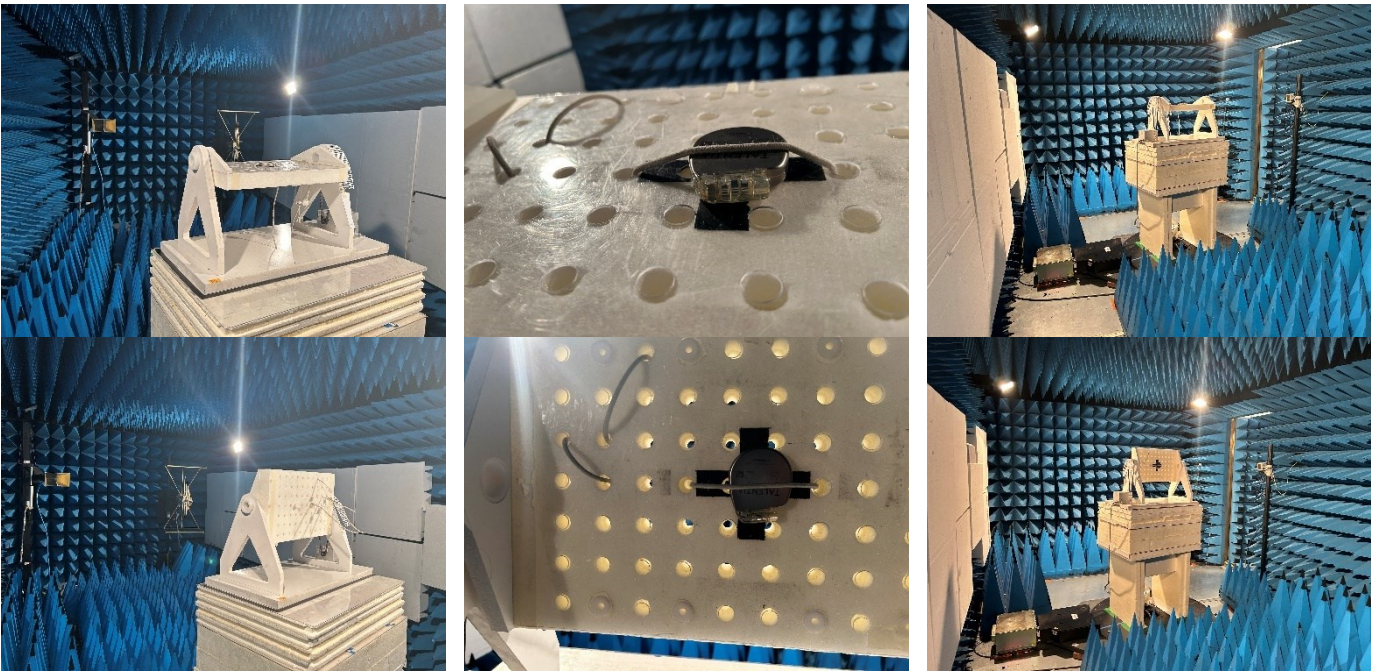

Photo of Unwanted Emissions in Restricted Frequency Bands



7.3. LIMIT

Measure at 300m		
Frequency range	Level	Detector
9kHz-490kHz	67.6dB μ V/m /F(kHz)	QPeak
Measure at 30m		
Frequency range	Level	Detector
490kHz-1.705MHz	87.6dB μ V/m /F(kHz)	QPeak
1.705MHz-30MHz	29.5dB μ V/m	QPeak
Measure at 10m		
Frequency range	Level	Detector
30MHz to 88MHz	29.5dB μ V/m	QPeak
88MHz to 216MHz	33dB μ V/m	QPeak
216MHz to 960MHz	35.5B μ V/m	QPeak
960MHz to 1000MHz	43.5dB μ V/m	QPeak
Above 1000MHz	63.5dB μ V/m	Peak
	43.5dB μ V/m	Average
Measure at 3m		
Frequency range	Level	Detector
30MHz to 88MHz	40dB μ V/m	QPeak
88MHz to 216MHz	43.5dB μ V/m	QPeak
216MHz to 960MHz	46B μ V/m	QPeak
960MHz to 1000MHz	54dB μ V/m	QPeak
Above 1000MHz	74dB μ V/m	Peak
	54dB μ V/m	Average



LCIE

7.4. TEST EQUIPMENT LIST

TEST EQUIPMENT USED					
Description	Manufacturer	Model	Identifier	Cal_Date	Cal_Due
Amplifier 10MHz - 18GHz	LCIE SUD EST	-	A7102082	05/22	05/24
Antenna Bi-log	AH System	SAS-521-7	C2040180	05/23	05/25
Antenna horn 18GHz	EMCO	3115	C2042029	03/22	03/25
BAT EMC	NEXIO	v3.21.0.32	L1000115	N/A	N/A
Cable 0.75m	-	18GHz	A5329900	08/22	08/24
Comb EMR HF	YORK	CGE01	A3169114	N/A	N/A
CONTROLLER	INSCO	CO3000	D3044034	N/A	N/A
Filter Matrice	LCIE SUD EST	Combined filters	A7484078	03/23	03/25
Multimeter - CEM	FLUKE	87	A1240251	10/23	10/25
Rehausse Table C3	LCIE	-	F2000507	N/A	N/A
Rehausse Table C3	LCIE	-	F2000511	N/A	N/A
Semi-Anechoic chamber #3 (BF)	SIEPEL	-	D3044017_BF	04/22	04/25
Semi-Anechoic chamber #3 (VSWR)	SIEPEL	-	D3044017_VSWR	04/22	04/25
SMA Cable 18GHz 0.5m	TELEDYNE	18GHz	A5330059	02/23	02/24
SMA Cable 18GHz 0.5m	TELEDYNE	18GHz	A5330060	02/23	02/24
SMA Cable 18GHz 0.6m	TELEDYNE	18GHz	A5330055	02/23	02/24
SMA Cable 18GHz 3.5m	TELEDYNE	18GHz	A5330058	02/23	02/24
SMA Cable 18GHz 6m	TELEDYNE	18GHz	A5330057	02/23	02/24
Spectrum analyzer	ROHDE & SCHWARZ	FSU 26	A4060058	09/23	09/25
Table C3	LCIE	-	F2000461	N/A	N/A
Thermo-hygrometer (PM1/2/3)	KIMO	HQ 210	B4206022	05/23	05/25
TILT	INSCO	TILT	D3044033	N/A	N/A
Turntable chamber (Cage#3)	ETS Lingren	Model 2165	F2000371	N/A	N/A
Turntable controller (Cage#3)	ETS Lingren	Model 2090	F2000444	N/A	N/A
Antenna horn 40GHz	SCHWARZBECK	BBHA 9170	C2042028	06/22	06/25
Cable 1m 40GHz	INTELLICONNECT	C-KPKP-1503-1M	A5329987	04/21	04/24
Emission Cable 0.5m (Ampl <-> receptor)	INTELLICONNECT	C-KPKP-1503-500MM	A5329988	04/23	04/26
Emission Cable 0.6m (Ampl <-> receptor)	TELEDYNE	A90-010-0.6MTR	A5330056	04/23	04/24
PRE-AMPLIFIER	LCIE SUD EST	PRE-AMPLIFIER (40GHz)	A7080078	09/22	09/24
SMK 1.2m (Ampl <-> chamber)	HUBER-SUHNER	SUCOFLEX 102	A5330062	04/23	04/26
SMK 1.2m Emission Cable 0.5m (Ampl <-> Chamber)	HUBER-SUHNER	SUCOFLEX 102	A5330063	04/23	04/24
Spectrum analyzer	ROHDE & SCHWARZ	FSV 40	A4060059	11/21	11/23



Antenna loop	ELECTRO-METRICS	EM-6879	C2040294	08/22	08/24
Antenna Mat (OATS)	ETS Lingren	2071-2	F2000392	N/A	N/A
Biconic Antenna	EATON	94455-1	C2040234	05/23	05/25
Cable (OATS)	-	1GHz	A5329623	09/23	09/24
Emission Cable	MICRO-COAX	1GHz	A5329656	09/23	09/24
Emission Cable	RADIALEX		A5329061	07/23	07/24
Emission Cable	CABELTEL	6GHz	A5329069	05/22	09/23
OATS	-	-	F2000409	08/23	08/24
Rehausse Table C1/OATS	LCIE	-	F2000512	N/A	N/A
Table C1/OATS	LCIE	-	F2000445	N/A	N/A
Turntable (OATS)	ETS Lingren	Model 2187	F2000403	N/A	N/A
Turntable / Mast controller (OATS)	ETS Lingren	Model 2066	F2000372	N/A	N/A

N/A: Not applicable

7.5. DIVERGENCE, ADDITION OR SUPPRESSION ON THE TEST SPECIFICATION

None



7.6. RESULTS

For all following measurements, worst case is presented with different configurations and modulations of EUT.

7.6.1. 9kHz to 26GHz

Graphs – Pre characterization:

Graph identifier	Polarization	Mode	Channel	EUT position	Comments
Emr# 1	0°/90°	TX	Single	Axis XY/Z	9KHz – 30MHz
Emr# 2	180°	TX	Single	Axis XY/Z	9KHz – 30MHz
Emr# 3	H/V	TX	Cmin	Axis XY/Z	30MHz - 14 GHZ
Emr# 4	H/V	TX	Cmid	Axis XY/Z	30MHz - 14 GHZ
Emr# 5	H/V	TX	Cmax	Axis XY/Z	30MHz - 14 GHZ
Emr# 6	H/V	TX	Cmin	Axis XY/Z	14 GHZ – 26GHz
Emr# 7	H/V	TX	Cmid	Axis XY/Z	14 GHZ – 26GHz
Emr# 8	H/V	TX	Cmax	Axis XY/Z	14 GHZ – 26GHz



L C I E

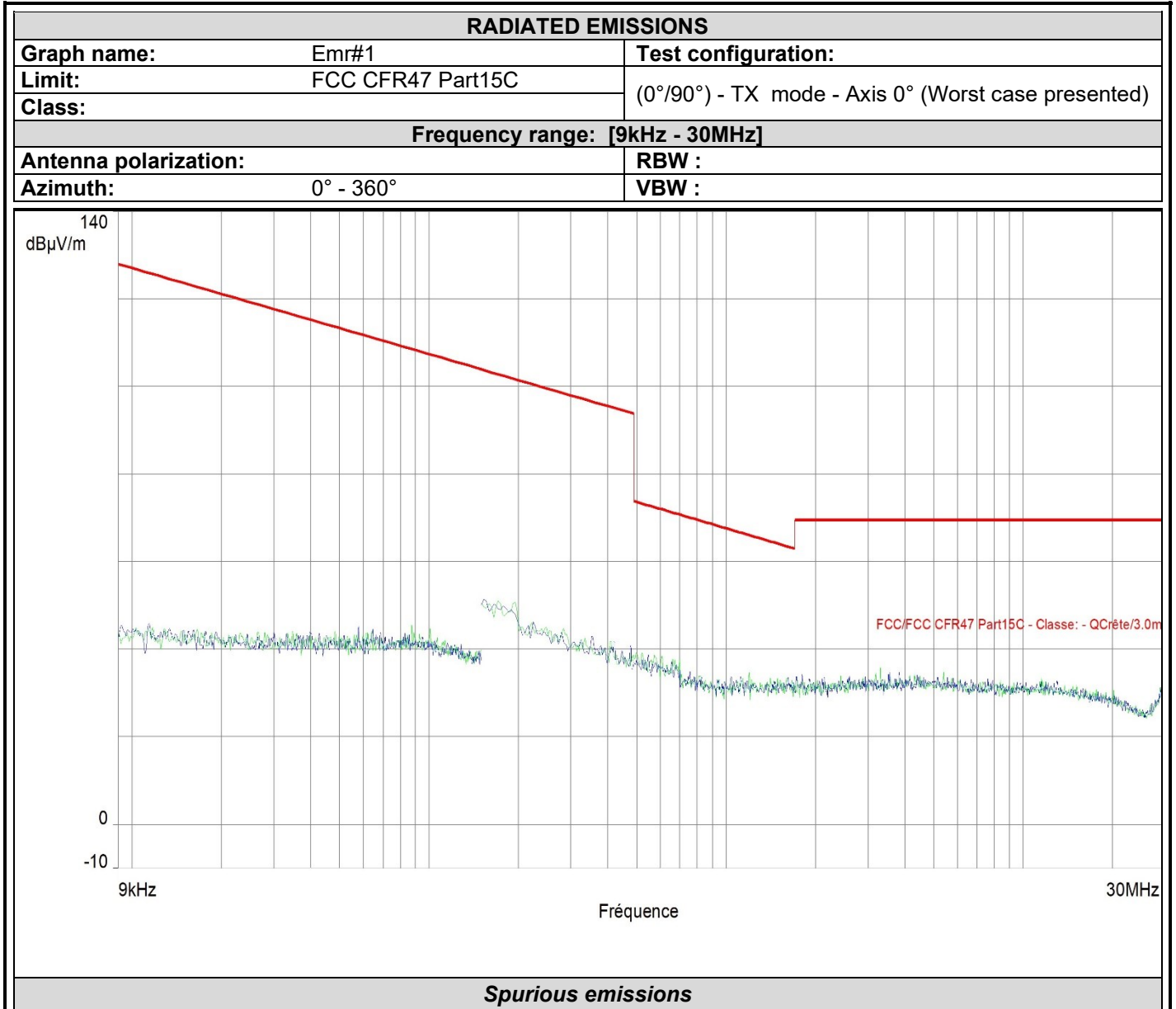

No significative frequency observed



L C I E

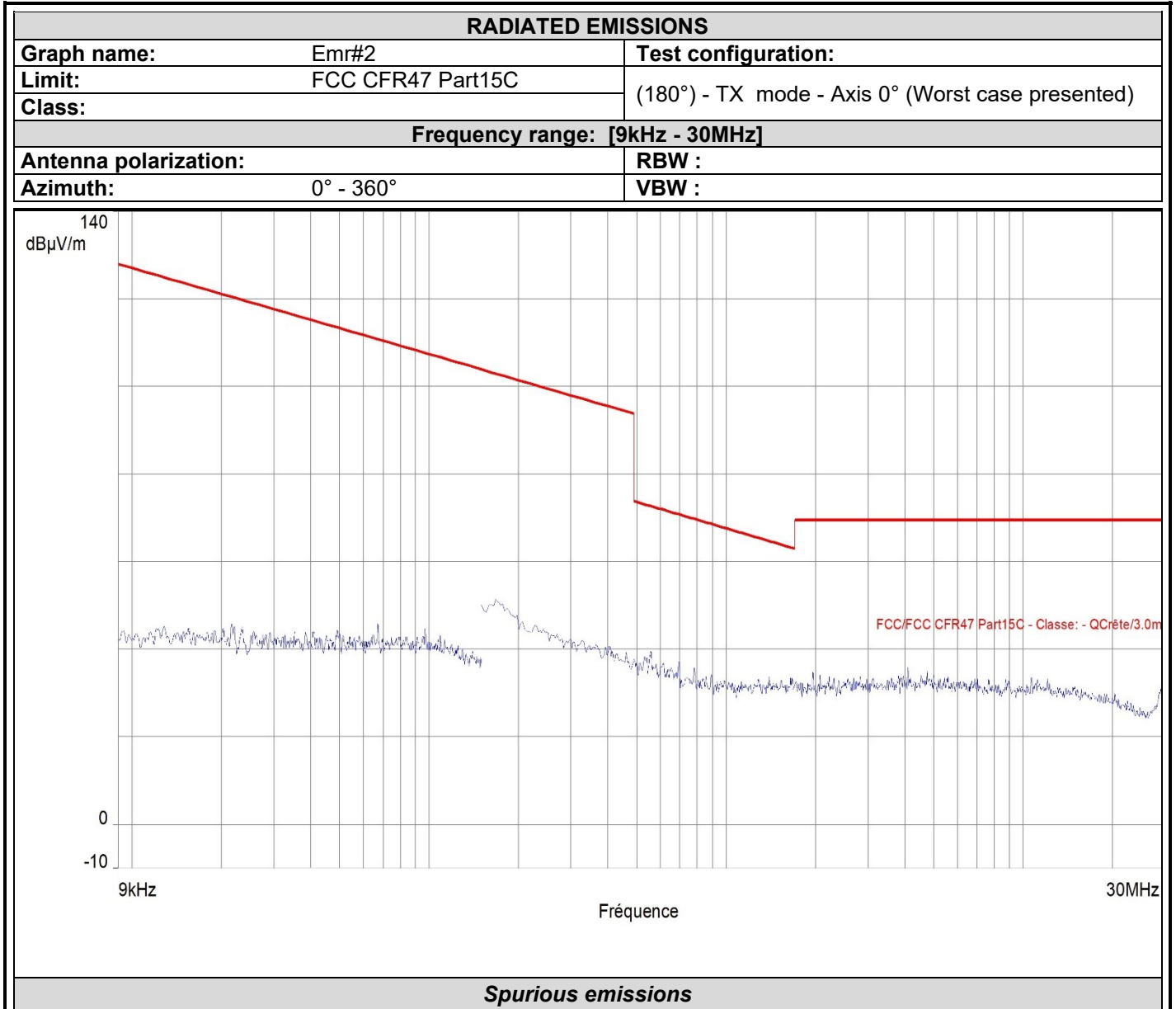

No significative frequency observed



L C I E

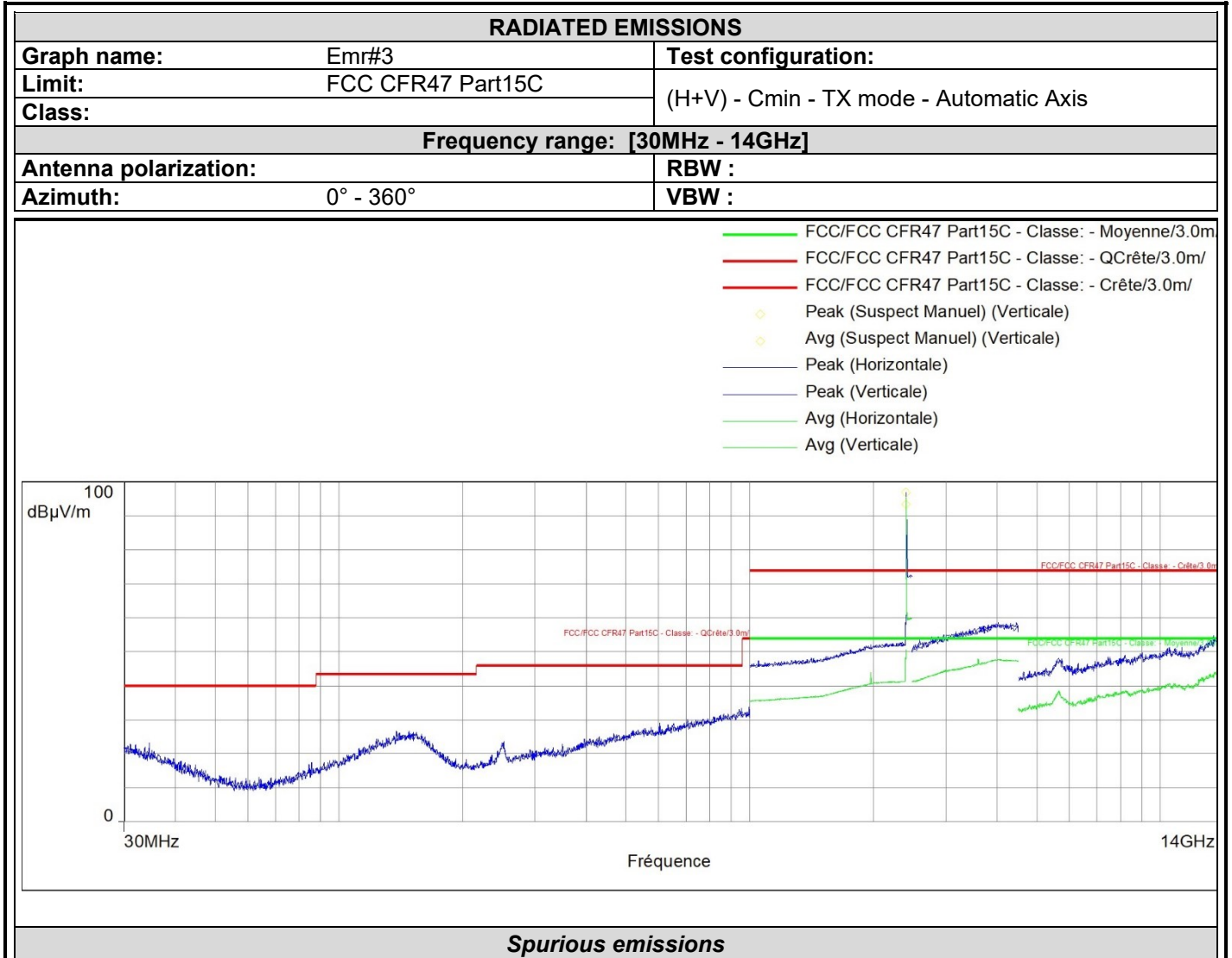

Frequency (MHz)	Peak (dBµV/m)	Lim.Peak (dBµV/m)	Avg (dBµV/m)	Lim.Avg (dBµV/m)	Polarization	Correction (dB)
2402.296*	96.8	74.0	93.4	54.0	Vertical	35.0

*Carrier frequency
No significant frequency observed due to RF module



L C I E

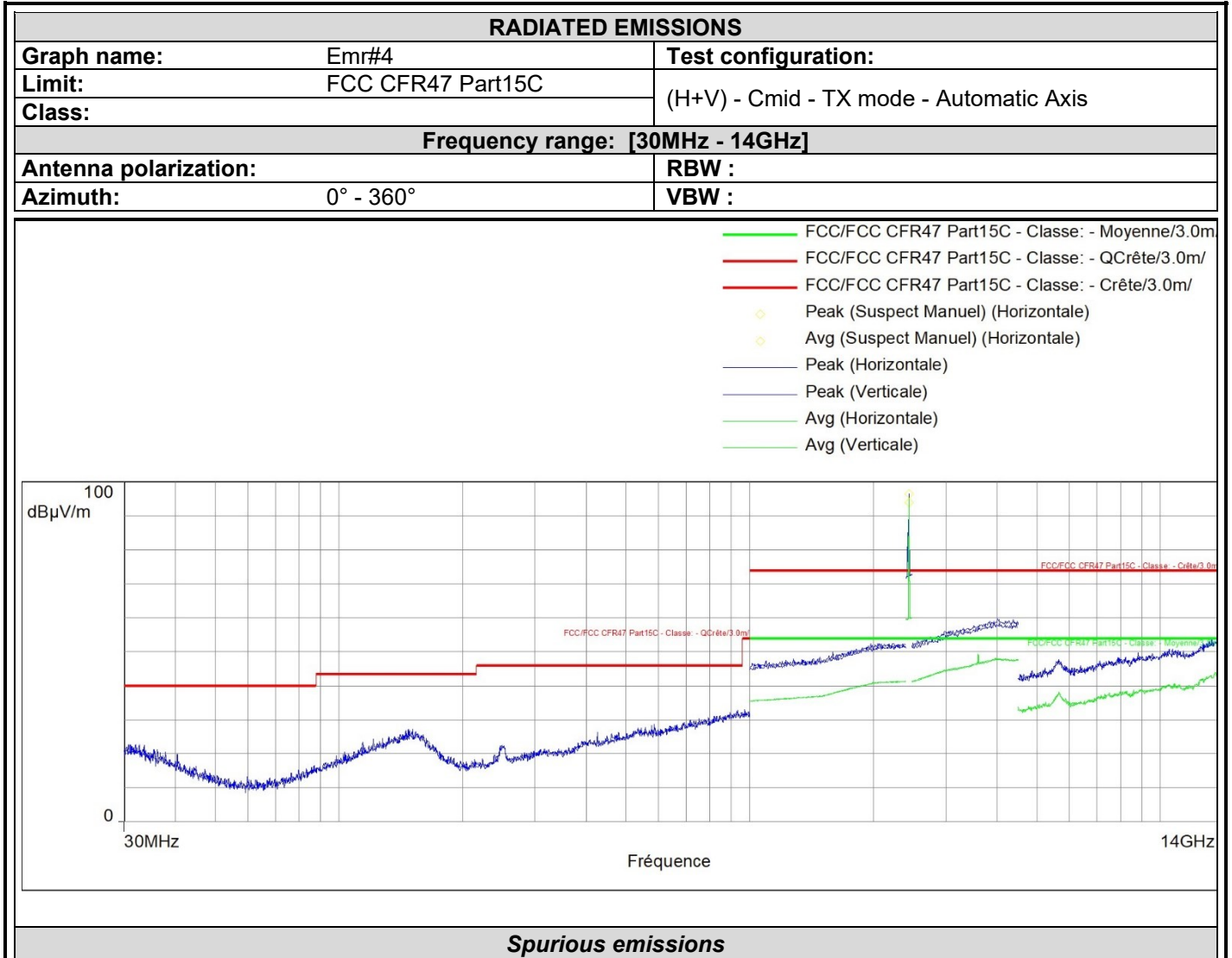

Frequency (MHz)	Peak (dBµV/m)	Lim.Peak (dBµV/m)	Avg (dBµV/m)	Lim.Avg (dBµV/m)	Polarization	Correction (dB)
2439.746*	96.5	74.0	94.0	54.0	Horizontal	35.1

*Carrier frequency
No significant frequency observed due to RF module



L C I E

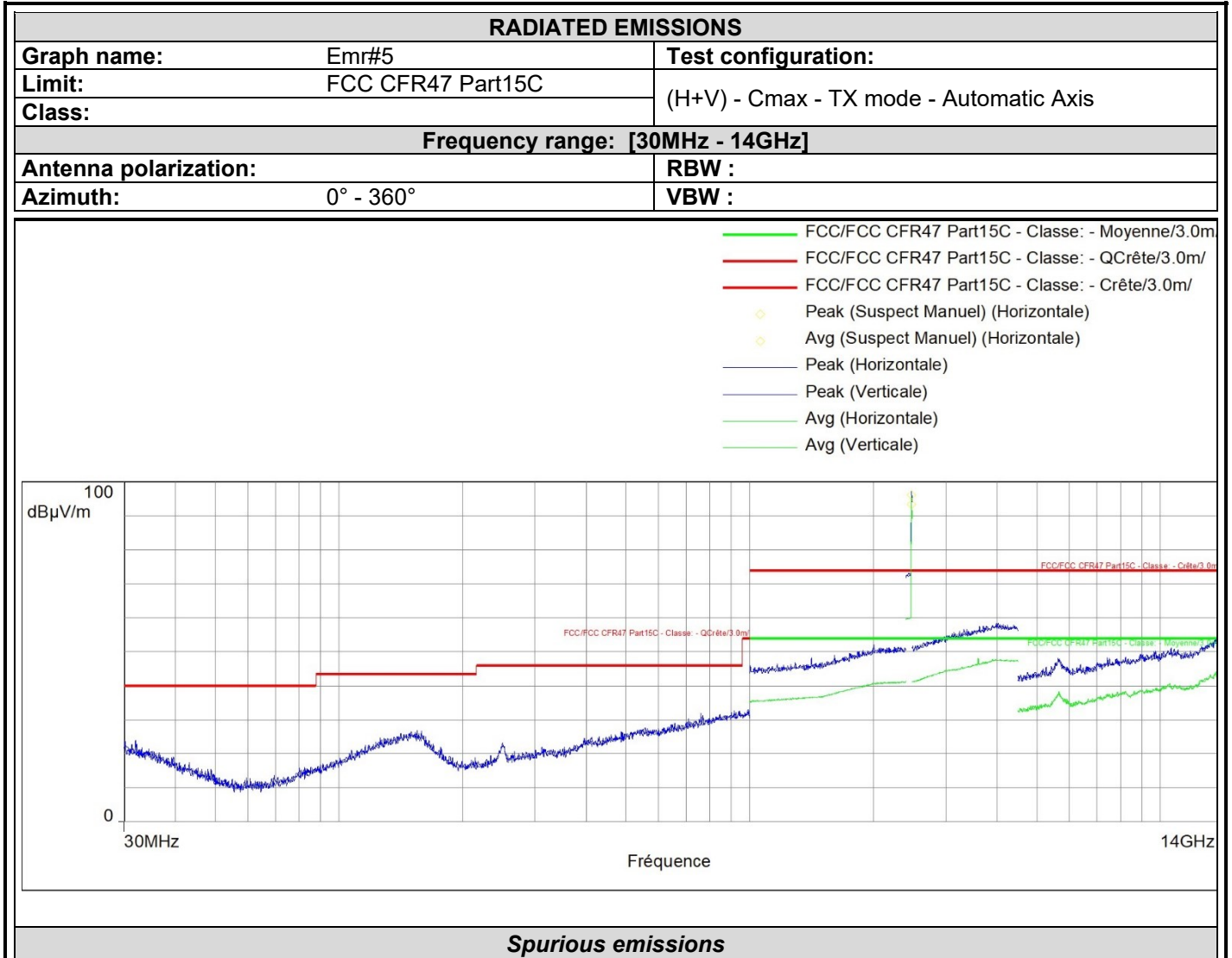

Frequency (MHz)	Peak (dBµV/m)	Lim.Peak (dBµV/m)	Avg (dBµV/m)	Lim.Avg (dBµV/m)	Polarization	Correction (dB)
2479.742*	96.2	74.0	93.4	54.0	Horizontal	35.1

*Carrier frequency
No significant frequency observed due to RF module



L C I E

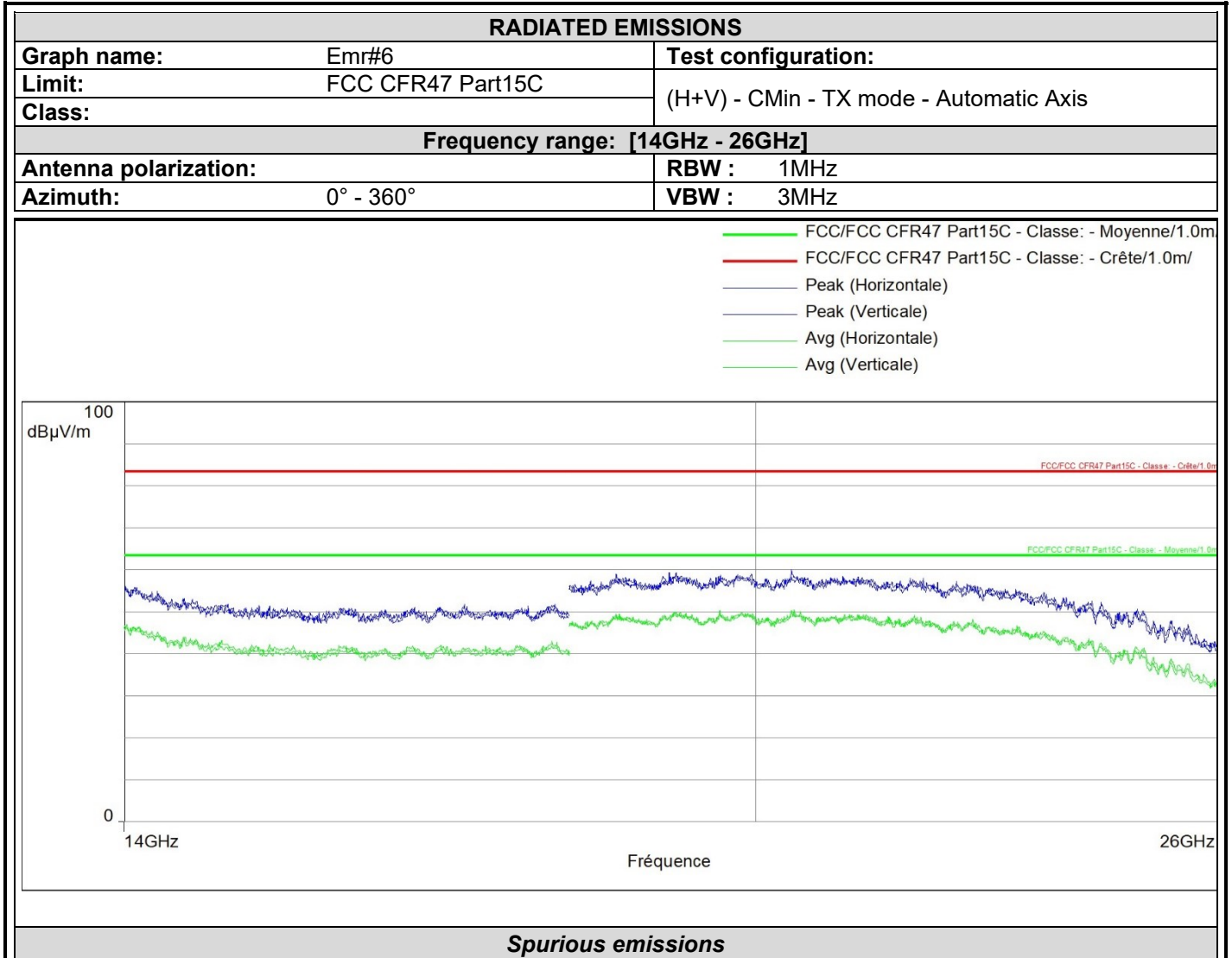

Spurious emissions

No significant frequency observed



L C I E

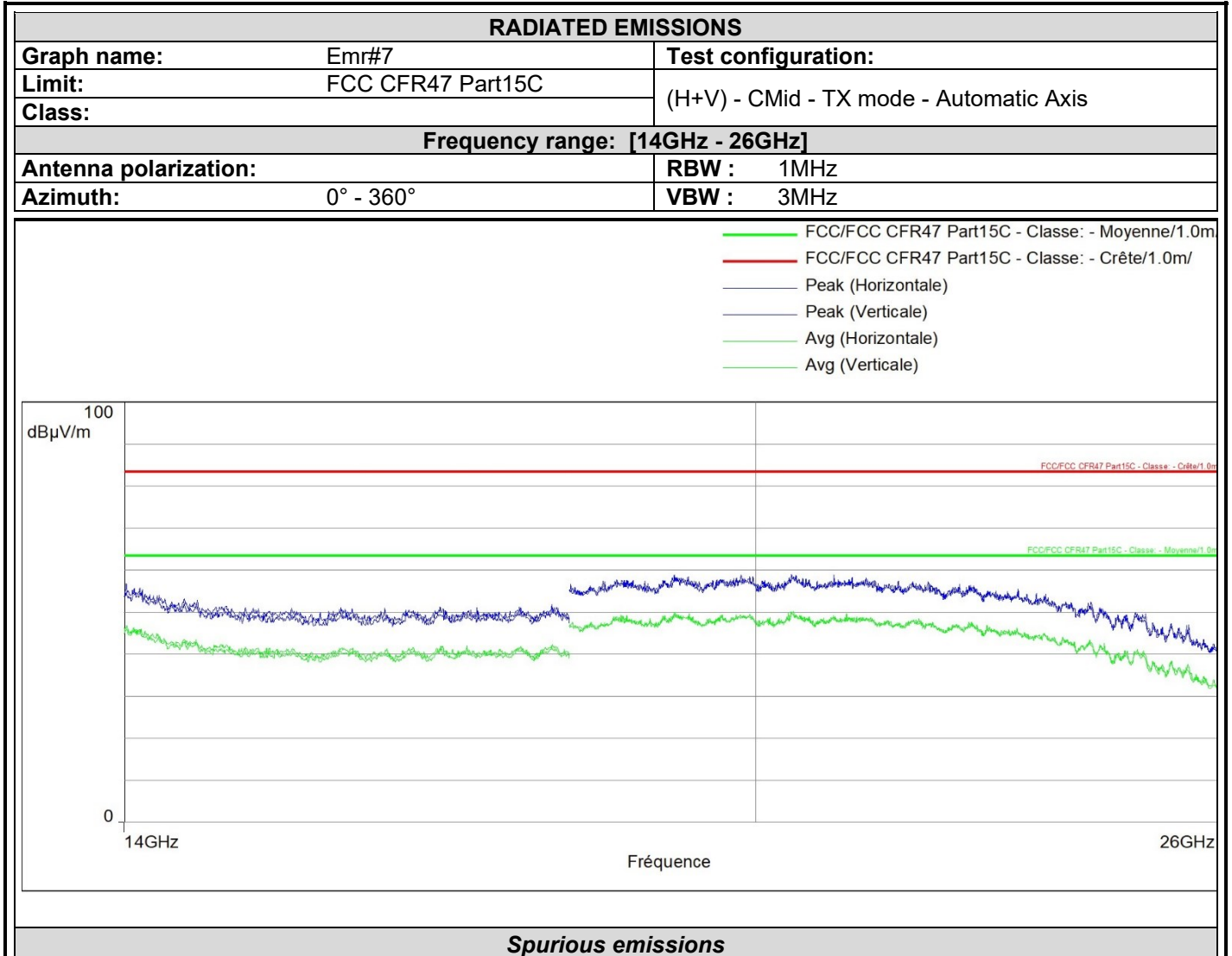

Spurious emissions

No significant frequency observed



L C I E

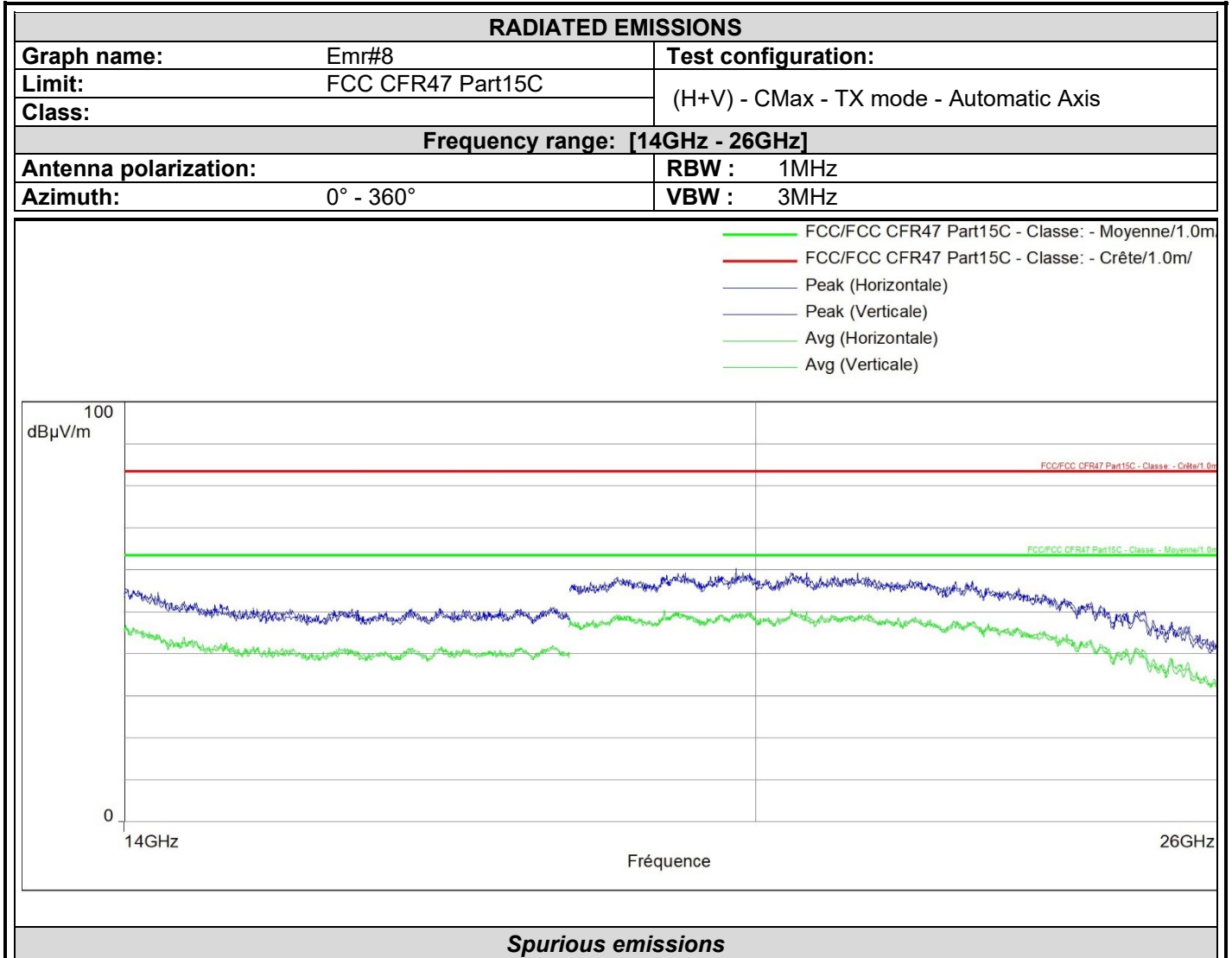

Spurious emissions

No significative frequency observed



7.6.2. Restricted Band

Graphs – Pre characterization:

Graph identifier	Polarization	Mode	Channel	EUT position	Comments
Emr# 1	H/V	TX	Cmin	Axis XY/Z	-
Emr# 2	H/V	TX	Cmid	Axis XY/Z	-
Emr# 3	H/V	TX	Cmax	Axis XY/Z	-

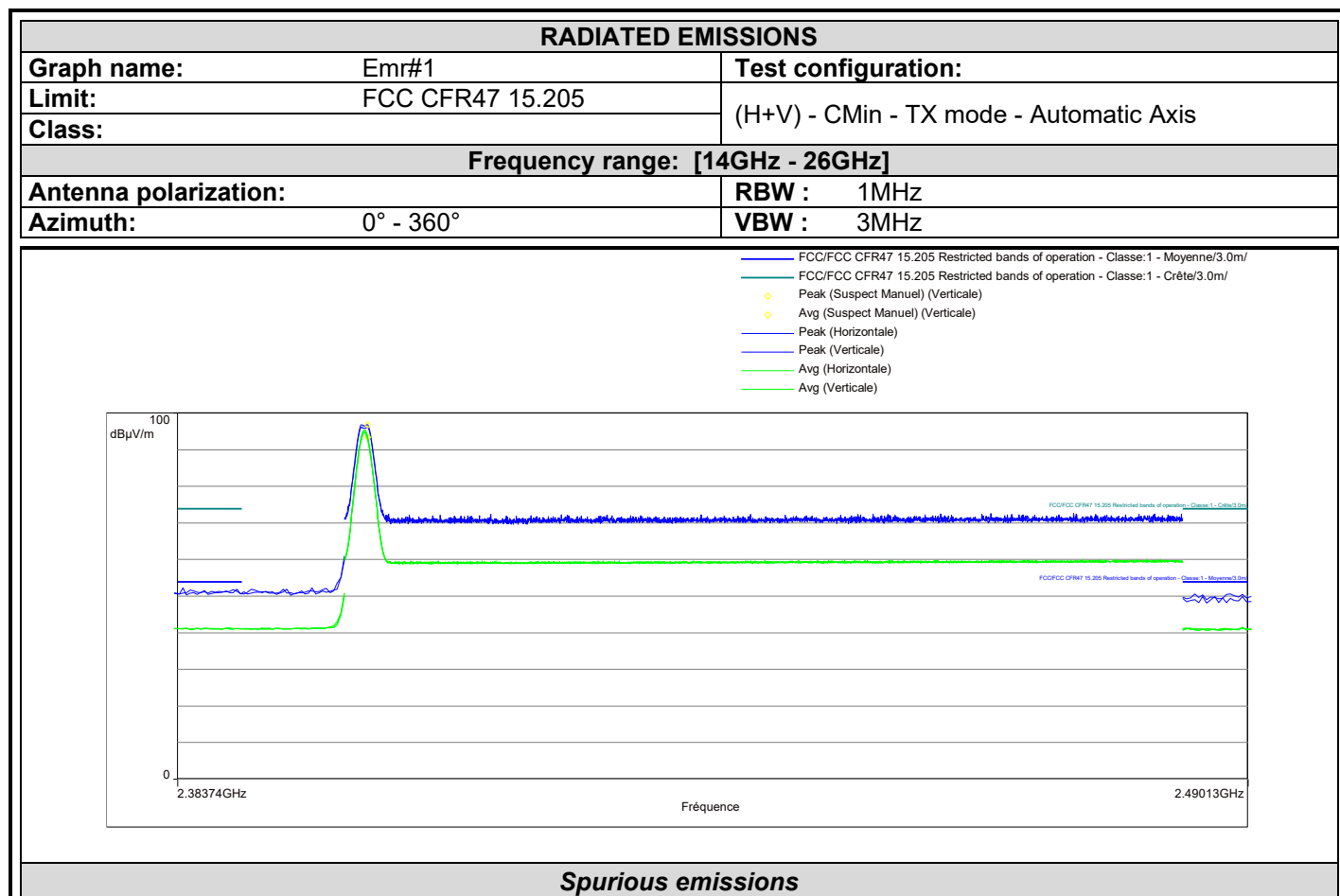

No significant frequency observed



L C I E

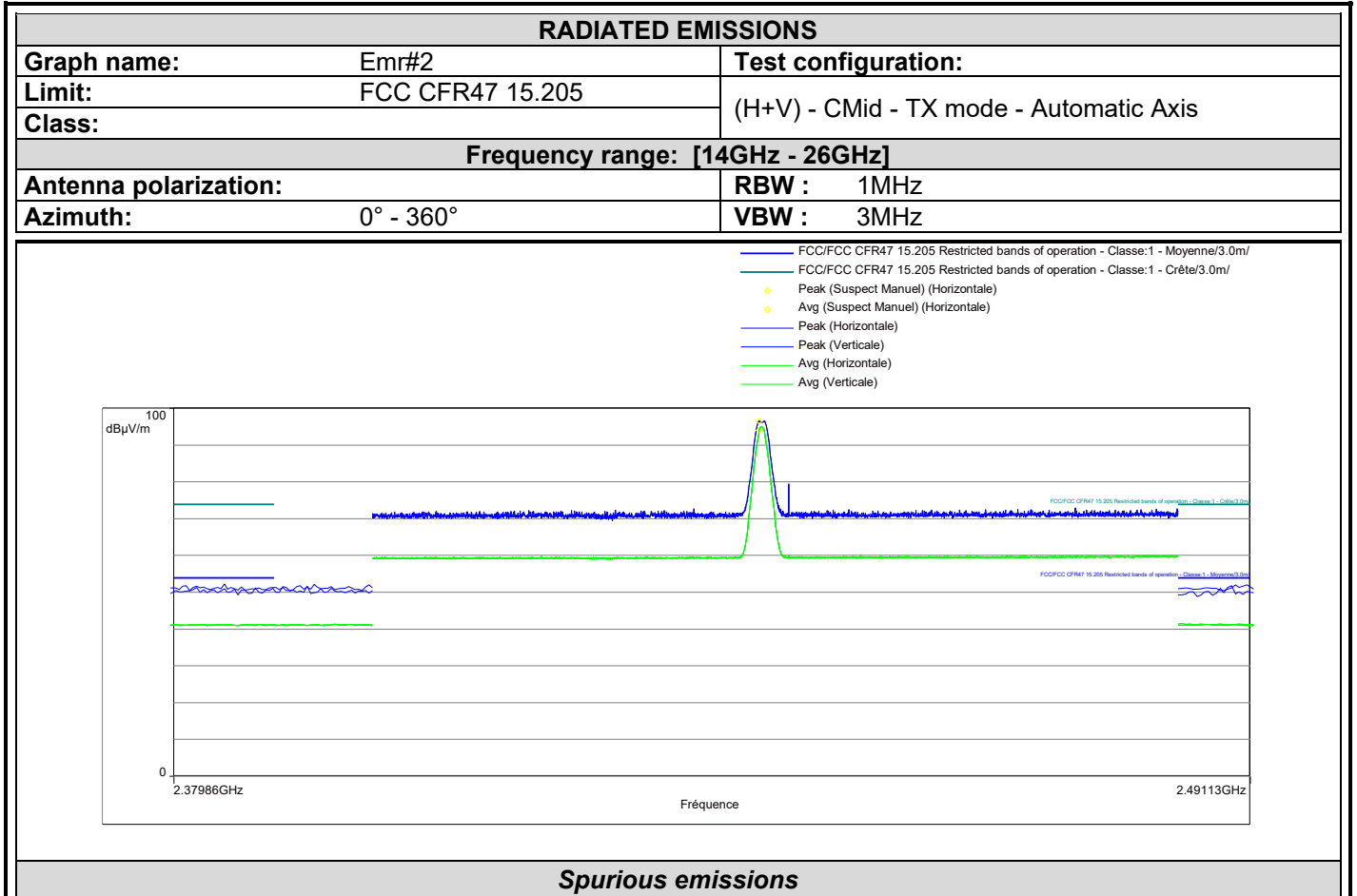

Spurious emissions

No significative frequency observed



L C I E

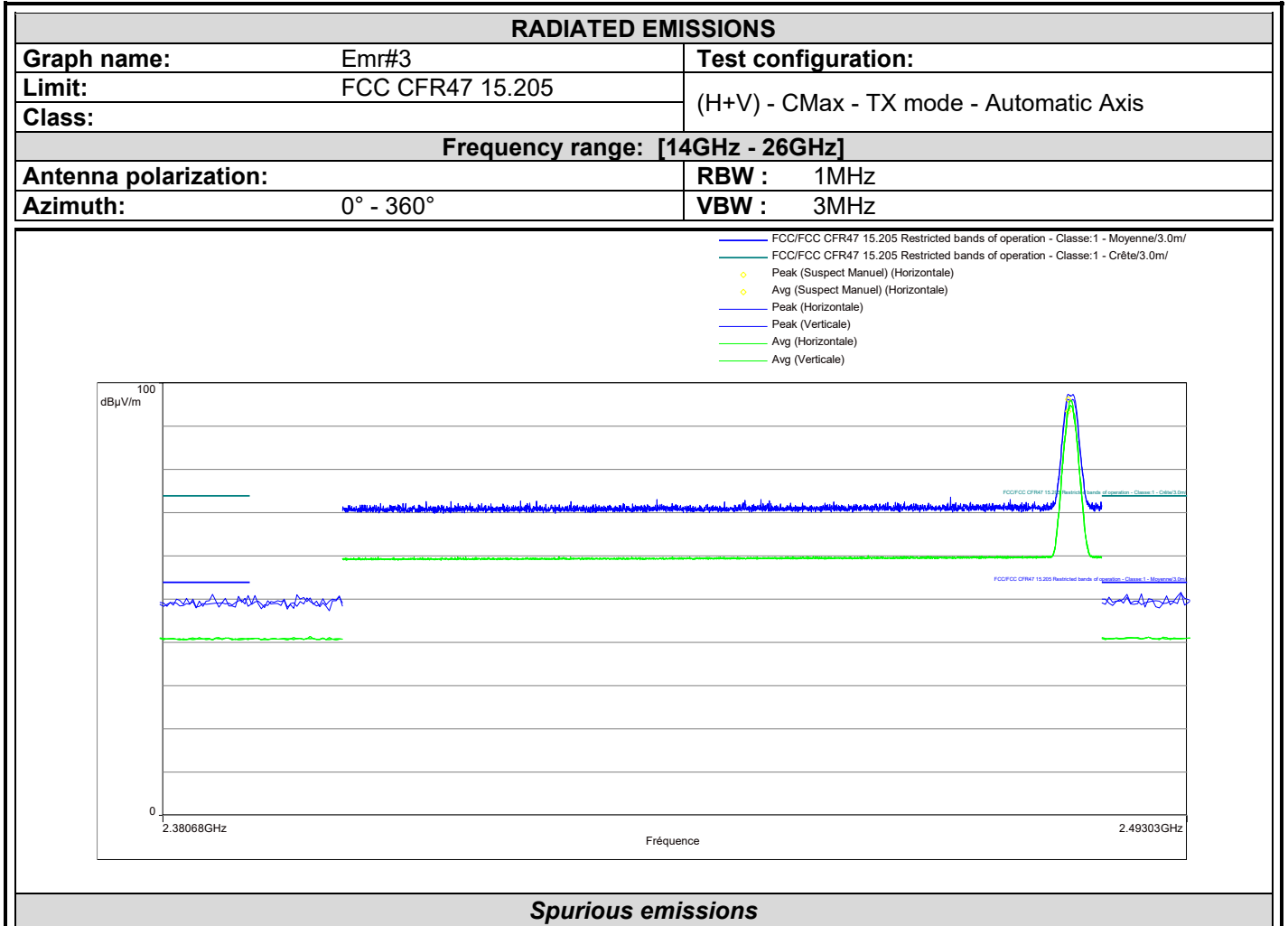

NO SIGNIFICATIVE FREQUENCY OBSERVED

7.7. CONCLUSION

Unwanted emissions in non-restricted bands measurement performed on the sample of the product **ENERGYA 4LV CRT-D 3744**, Sn: **Q19JG037** , **Q19D503E**, in configuration and description presented in this test report, show levels compliant to the **47 CFR PART 15.247 & RSS 247** limits.



8. UNCERTAINTIES CHART

Kind of measurement	Wide uncertainty laboratory
Occupied Channel Bandwidth	±2.8 %
Humidity	±3.2 %
Power Spectral Density, Conducted	±1.7 dB
Radio frequency	±0.3 ppm
RF power, conducted	±1.2 dB
RF power, radiated (Full anechoic chamber above 1GHz)	±3.7 dB
RF power, radiated (Semi anechoic chamber & open test site)	±5.6 dB
Spurious emission, conducted	±2.3 dB
Spurious emission, radiated (Full anechoic chamber above 1GHz)	±3.8 dB
Spurious emission, radiated (Semi anechoic chamber & open test site)	±5.7 dB
Temperature	±0.75 °C
Time	±2.3 %
Voltage	±1.7 %

The uncertainty values calculated by the laboratory are lower than limit uncertainty values defined by the standard. The conformity of the sample is directly established by the applicable limit values. This table includes all uncertainties maximum feasible for testing in the laboratory, whether or not made in this report.