



**FCC Certification Test Report**  
**For the**  
**MALA GeoScience USA INC.**  
**MSR 300 Movement and Surveying Radar**

**FCC ID: YSD-5840-SL-3000**

WLL JOB# 11061  
September 2, 2009

Re-issued:  
Under WLL Job# 11603  
September 16, 2010

Prepared for:

**MALA GeoScience USA INC.**  
**P.O. Box 80430**  
**Charleston, SC 29416**

Prepared By:

**Washington Laboratories, Ltd.**  
**7560 Lindbergh Drive**  
**Gaithersburg, Maryland 20879**



**Testing Certificate AT-1448**

**FCC Certification Test Report**  
**For the**  
**MALA Geoscience USA INC.**  
**MSR 300 Movement and Surveying Radar**  
**FCC ID: YSD-5840-SL-3000**

**September 2, 2009**

WLL JOB# 11061

Re-issued September 16, 2010  
Under Job# 11603

Prepared by:

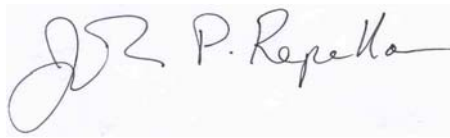

---

John P. Repella  
Q A Manager

Reviewed by:



---

Steven D. Koster  
EMC Operations Manager

## Abstract

This report has been prepared on behalf of MALA GeoScience USA INC. to support the attached Application for Equipment Authorization. The test report and application are submitted for a Licensed Transmitter under Part 90 of the FCC Rules and Regulations (10/2008). This Certification Test Report documents the test configuration and test results for a MALA GeoScience USA INC. MSR 300 Movement and Surveying Radar.

Testing was performed on an Open Area Test Site (OATS) of Washington Laboratories, Ltd, 7560 Lindbergh Drive, Gaithersburg, MD 20879. Site description and site attenuation data have been placed on file with the FCC's Sampling and Measurements Branch at the FCC laboratory in Columbia, MD. The Industry Canada OATS numbers are 3035A-1 and 3035A-2 for Washington Laboratories, Ltd. Site 1 and Site 2, respectively.

At the time of the initial issuance of this report, Washington Laboratories, Ltd. was accepted by the FCC and approved by the American Association for Laboratory Accreditation (A2LA) under Certificate 2675.01 as an independent FCC test laboratory.

As of April 1, 2010 Washington Laboratories, Ltd. is accepted by the FCC and approved by Assured Calibration and Laboratory Accreditation Select Services (ACLASS) under testing certificate AT-1448.

The Testing completed by Washington Laboratories LTD. for the MALA GeoScience USA INC. MSR 300 Movement and Surveying Radar complies with the limits for a Licensed Transmitter device under FCC Part 90.

No compliance statement is made with regard to the testing completed by SunSpace and Information Systems.

<b>Revision History</b>	<b>Reason</b>	<b>Date</b>
Rev 0	Initial Release	09/02/2009
Rev 1	Re-released under new Job# 11603. This revision incorporates references to third party test report completed by SunSpace and Information Systems, LTD for power measurements. The power measurements made at WLL were removed from this report.	08/18/2010

## Table of Contents

<i>Abstract</i> .....	<i>ii</i>
<i>1 Introduction</i> .....	<i>1</i>
1.1 Compliance Statement .....	1
1.2 Test Scope.....	1
1.3 Contract Information.....	1
1.4 Test Dates .....	1
1.5 Test and Support Personnel .....	1
1.6 Abbreviations.....	2
<i>2 Equipment Under Test</i> .....	<i>3</i>
2.1 EUT Identification & Description .....	3
2.2 Test Configuration .....	3
2.3 Testing Algorithm.....	6
2.4 Test Location .....	6
2.5 Measurements .....	6
2.6 Measurement Uncertainty.....	6
<i>3 Test Equipment</i> .....	<i>8</i>
<i>4 Test Results</i> .....	<i>9</i>
4.1 RF Power Output: (FCC Part §2.1046) .....	9
4.2 Occupied Bandwidth: (FCC Part §90.210(c)) .....	9
4.3 Conducted Spurious Emissions at Antenna Terminals (FCC Part §2.1051) .....	13
4.4 Radiated Spurious Emissions: (FCC Part §2.1053).....	21
4.5 Frequency Stability: (FCC Part §2.1055).....	23

### List of Tables

Table 1: Device Summary .....	3
Table 2: Test Equipment List.....	8
Table 3: Occupied Bandwidth Results.....	13
Table 4: Radiated Emission Test Data.....	22
Table 5: Frequency Deviation as a Function of Temperature .....	23
Table 6: Frequency Deviation as a Function of Voltage .....	24

### List of Figures

Figure 1: Test Configuration.....	4
Figure 2: Normal Operation Output Signal .....	5
Figure 3: Occupied Bandwidth, Low Channel .....	10
Figure 4: Occupied Bandwidth, Mid Channel.....	11
Figure 5: Occupied Bandwidth, High Channel.....	12
Figure 6: Conducted Spurious Emissions, Center Channel 30 - 1000MHz .....	14
Figure 7: Conducted Spurious Emissions, Center Channel 1 – 5GHz .....	15
Figure 8: Conducted Spurious Emissions, Center Channel 5 – 9.8GHz .....	16
Figure 9: Conducted Spurious Emissions, Center Channel 9.9 - 15GHz.....	17
Figure 10: Conducted Spurious Emissions, Center Channel 15 - 25GHz.....	18
Figure 11: Conducted Spurious Emissions, Center Channel 25 - 35GHz.....	19
Figure 12: Conducted Spurious Emissions, Center Channel 35 – 40GHz .....	20

## 1 Introduction

### 1.1 Compliance Statement

The MALA GeoScience USA INC. MSR 300 Movement and Surveying Radar complies with the limits for a Licensed Transmitter device under FCC Part 90 (10/2008).

### 1.2 Test Scope

Tests for radiated and conducted (at antenna terminal) emissions were performed. All measurements were performed in accordance with ANSI C63.4-2003 and ANSI/TIA/EIA-603C. The measurement equipment conforms to ANSI C63.2 Specifications for Electromagnetic Noise and Field Strength Instrumentation.

### 1.3 Contract Information

Customer:	MALA GeoScience USA INC. P.O. Box 80430 Charleston, SC 29416
Purchase Order Number:	Check
Quotation Number:	64908

### 1.4 Test Dates

Testing was performed on the following date(s):	7/30/09 to 8/4/09
---	-------------------

### 1.5 Test and Support Personnel

Washington Laboratories, LTD	Steven Dovell, John P. Repella
Client Representative	Matt J. Wolf

## 1.6 Abbreviations

<b>A</b>	<b>Ampere</b>
<b>ac</b>	<b>alternating current</b>
<b>AM</b>	<b>Amplitude Modulation</b>
<b>Amps</b>	<b>Amperes</b>
<b>b/s</b>	<b>bits per second</b>
<b>BW</b>	<b>BandWidth</b>
<b>CE</b>	<b>Conducted Emission</b>
<b>cm</b>	<b>centimeter</b>
<b>CW</b>	<b>Continuous Wave</b>
<b>dB</b>	<b>deciBel</b>
<b>dc</b>	<b>direct current</b>
<b>EMI</b>	<b>Electromagnetic Interference</b>
<b>EUT</b>	<b>Equipment Under Test</b>
<b>FM</b>	<b>Frequency Modulation</b>
<b>G</b>	<b>giga - prefix for 10<sup>9</sup> multiplier</b>
<b>Hz</b>	<b>Hertz</b>
<b>IF</b>	<b>Intermediate Frequency</b>
<b>k</b>	<b>kilo - prefix for 10<sup>3</sup> multiplier</b>
<b>LISN</b>	<b>Line Impedance Stabilization Network</b>
<b>M</b>	<b>Mega - prefix for 10<sup>6</sup> multiplier</b>
<b>m</b>	<b>meter</b>
<b>μ</b>	<b>micro - prefix for 10<sup>-6</sup> multiplier</b>
<b>NB</b>	<b>Narrowband</b>
<b>QP</b>	<b>Quasi-Peak</b>
<b>RE</b>	<b>Radiated Emissions</b>
<b>RF</b>	<b>Radio Frequency</b>
<b>rms</b>	<b>root-mean-square</b>
<b>SN</b>	<b>Serial Number</b>
<b>S/A</b>	<b>Spectrum Analyzer</b>
<b>V</b>	<b>Volt</b>

## 2 Equipment Under Test

### 2.1 EUT Identification & Description

The MALA GeoScience USA INC. MSR 300 Movement and Surveying Radar (EUT) is intended to be used as a monitor to detect surface movement. The EUT then generates a warning of impending failure so that mine personnel and equipment maybe moved prior to the failure. MSR can also be used to generate survey data for the mine; this unit is not your typical radar system. It is a FMCW (frequency-modulated continuous wave). It does not use a pulse width or rep rate. It simply scans from 9.7GHz to 10GHz repeatedly with no modulation, just a simple CW signal.

**Table 1: Device Summary**

ITEM	DESCRIPTION
Manufacturer:	MALA GeoScience USA INC.
FCC ID:	XOP-5840-SL-3000
Model:	MSR 300 Movement and Surveying Radar
FCC Rule Parts:	§90.103
Frequency Range:	9.775GHz – 10.00GHz
Maximum Output Power:	0.054 W (17.34 dbm)(See SunSpace Test Report)
Modulation:	FMCW
Necessary Bandwidth:	0 Hz
Keying:	Automatic
Type of Information:	None
Number of Channels:	Swept
Power Output Level	Fixed
Antenna Connector	SMA
Antenna Type	Parabolic dish reflector, 38dB
Frequency Tolerance:	specified by station authority
Emission Type(s):	F0N
Interface Cables:	Tx = SMA, Rx = SMA, Control = 23 pin Twist lock
Power Source & Voltage:	24VDC

### 2.2 Test Configuration

The MSR 300 Movement and Surveying Radar was configured as a self contained trailer mounted unit. See Figure 1.



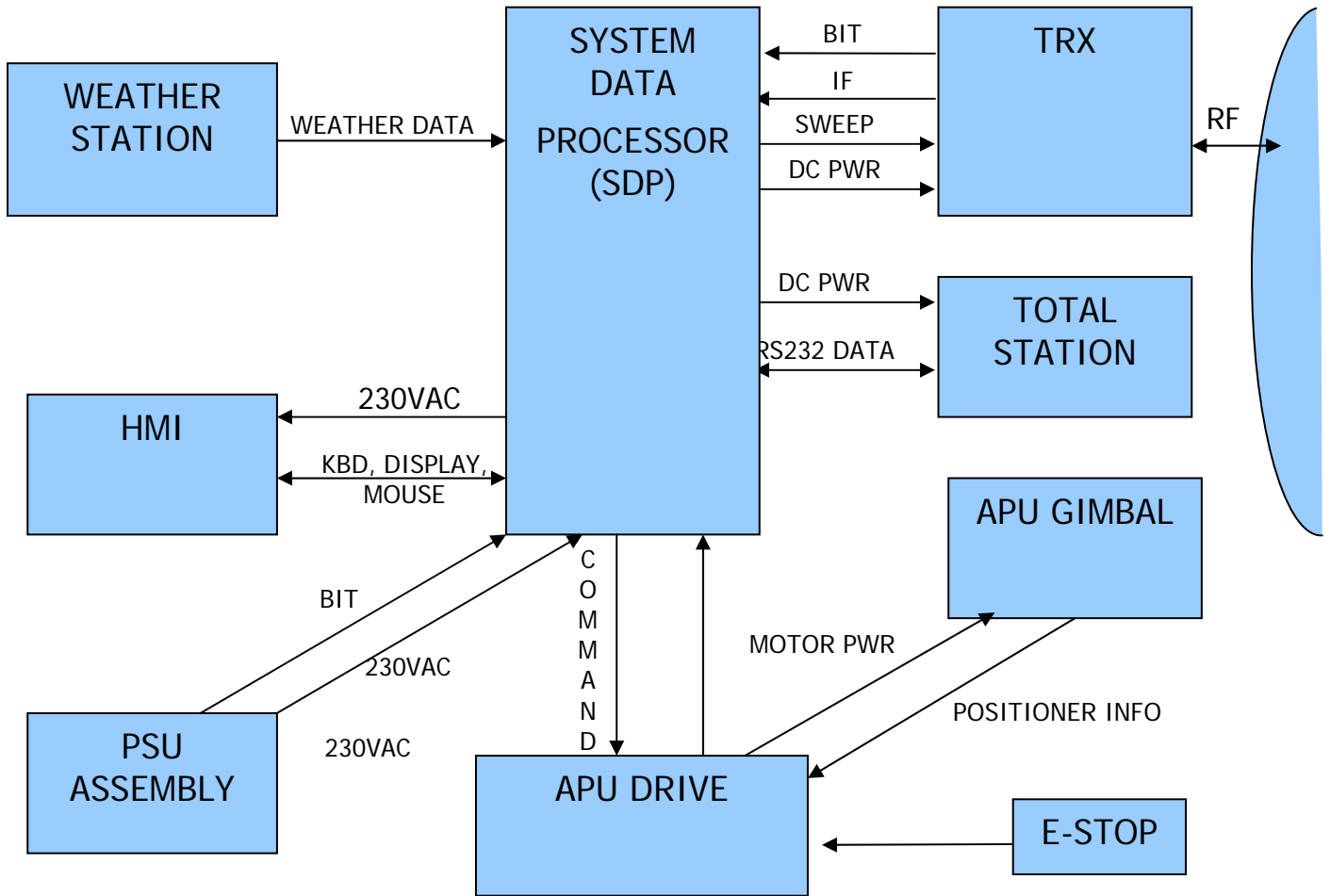

**Figure 1: Test Configuration**

Under normal operation, the EUT sweeps a CW signal from 9.775GHz to 10GHz. **Error! Reference source not found.** is a plot of the normal operational output of the EUT.

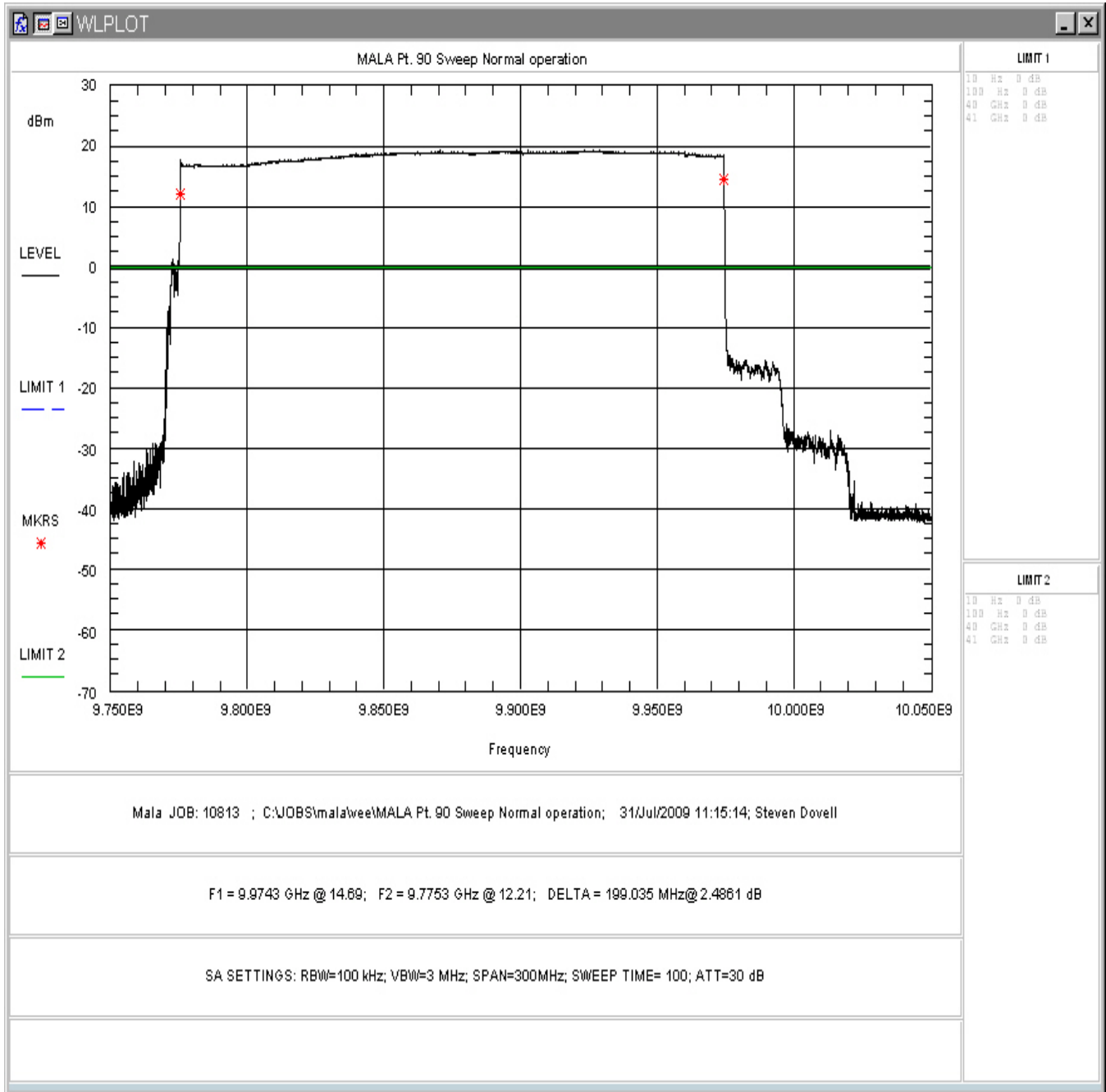

Figure 2: Normal Operation Output Signal

### 2.3 Testing Algorithm

The MSR 300 Movement and Surveying Radar was operated by selecting the operating mode, CW or Sweep, by pressing PB0 on the control board. Each press of PB0 cycled the EUT mode from Normal Sweep to CW – Start Of Sweep Frequency to CW – 9.8GHz to CW – 9.9GHz to CW – 10GHz.

Conducted measurements were taken at the TX port (J14) of the Transceiver module. EIRP measurements were made with J14 terminated into a 50 ohm load.

Worst case emission levels are provided in the test results data.

### 2.4 Test Location

All measurements herein were performed at Washington Laboratories, Ltd. test center in Gaithersburg, MD. Site description and site attenuation data have been placed on file with the FCC's Sampling and Measurements Branch at the FCC laboratory in Columbia, MD. The Industry Canada OATS numbers are 3035A-1 and 3035A-2 for Washington Laboratories, Ltd. Site 1 and Site 2, respectively. Washington Laboratories, Ltd. has been accepted by the FCC and approved by Assured Calibration and Laboratory Accreditation Select Services (ACLASS) under Testing Certificate AT-1448 as an independent FCC test laboratory.

### 2.5 Measurements

#### 2.5.1 References

ANSI C63.2 Specifications for Electromagnetic Noise and Field Strength Instrumentation

ANSI C63.4 American National Standard for Methods of Measurement of Radio-Noise Emissions from Low-Voltage Electrical and Electronic Equipment in the Range of 9 kHz to 40 GHz

Land Mobile FM or PM Communications Equipment Measurement and Performance Standards (ANSI/TIA/EIA-603C)

### 2.6 Measurement Uncertainty

All results reported herein relate only to the equipment tested. The basis for uncertainty calculation uses ANSI/NCSL Z540-2-1997 with a type B evaluation of the standard uncertainty. Elements contributing to the standard uncertainty are combined using the method described in Equation 1 to arrive at the total standard uncertainty. The standard uncertainty is multiplied by the coverage factor to determine the expanded uncertainty which is generally accepted for use in commercial, industrial, and regulatory applications and when health and safety are concerned (see Equation 2). A coverage factor was selected to yield a 95% confidence in the uncertainty estimation.

**Equation 1: Standard Uncertainty**

$$u_c = \pm \sqrt{\frac{a^2}{div_a^2} + \frac{b^2}{div_b^2} + \frac{c^2}{div_c^2} + \dots}$$

Where  $u_c$  = standard uncertainty

$a, b, c, \dots$  = individual uncertainty elements

$Div_{a, b, c}$  = the individual uncertainty element divisor based on the probability distribution

Divisor = 1.732 for rectangular distribution

Divisor = 2 for normal distribution

Divisor = 1.414 for trapezoid distribution

### Equation 2: Expanded Uncertainty

$$U = k u_c$$

Where  $U$  = expanded uncertainty

$k$  = coverage factor

$k \leq 2$  for 95% coverage (ANSI/NCSL Z540-2 Annex G)

$u_c$  = standard uncertainty

The measurement uncertainty complies with the maximum allowed uncertainty from CISPR 16-4-2. Measurement uncertainty is not used to adjust the measurements to determine compliance. The expanded uncertainty values for the various scopes in the WLL accreditation are provided in Table 2 below.

**Table 2: Expanded Uncertainty List**

Scope	Standard(s)	Expanded Uncertainty
Conducted Emissions	CISPR11, CISPR22, CISPR14, FCC Part 15	2.63 dB
Radiated Emissions	CISPR11, CISPR22, CISPR14, FCC Part 15	4.55 dB

### 3 Test Equipment

Table 3 shows a list of the test equipment used for measurements along with the calibration information.

**Table 3: Test Equipment List**

Test Name: <b>FCC Part 90.103</b>		Test Date: <b>08/04/2009</b>	
<b>Asset #</b>	<b>Manufacturer/Model</b>	<b>Description</b>	<b>Cal. Due</b>
00067	HP, 8564E	Analyzer, Spectrum	10/10/2009
00597	WATLOW, TNNY-VRSA-0001	Chamber T10rs	06/01/2010
00034	EMCO, BIA-30	Antenna, Biconical	02/20/2010
00007	ARA, LPB-2520	Antenna, Biconilog Antenna	06/17/2010
00028	EMCO, 3146	Antenna, Log Periodic	10/02/2010
00522	HP, 8449B	Pre-Amplifier, 1-26.5GHZ	07/21/2010
00065	HP, 8447D	Pre-Amplifier, RF, 50KHZ-1GHZ	12/19/2009
00004	ARA, DRG-118/A	Antenna, DRG, 1-18GHZ	02/06/2011
00001	A.H., Systems, SAS-200/518	Antenna, LP, 1-18GHZ	04/29/2010
00083	HP, 11970U	Mixer, Harmonic	06/09/2010
00210	NARDA, V638	Horn, Standard, Gain	12/14/2012
00209	NARDA V637	Horn, Standard, Gain	12/14/2012
00453	A.H., Systems, PAM1840	Pre-Amplifier, 18GHZ-40 GHZ	06/19/2010

## 4 Test Results

### 4.1 RF Power Output: (FCC Part §2.1046)

The measurements for this section are recorded in the test report provided by SunSpace and Information Systems, LTD.

*“This accredited organization (WLL) maintains ACLASS accreditation to ISO/IEC 17025 for the specific tests listed in ACLASS Testing Certificate #AT-1448. The tests results included in the SunSpace report, however, are not covered by this accreditation.”*

### 4.2 Occupied Bandwidth: (FCC Part §90.210(c))

Occupied bandwidth was performed by coupling the output of the EUT to the input of a spectrum analyzer. The mask was determined using the criteria specified in FCC Part §90.210(c).

For transmitters that are not equipped with an audio low-pass filter, the power of any emission must be attenuated below the unmodulated carrier output power (P) as follows: (1) On any frequency removed from the center of the authorized bandwidth by a displacement frequency (fd in kHz) of more than 5 kHz, but not more than 10 kHz: At least  $83 \log (fd/5)$  dB; (2) On any frequency removed from the center of the authorized bandwidth by a displacement frequency (fd in kHz) of more than 10 kHz, but not more than 250 percent of the authorized bandwidth: At least  $29 \log (fd /11)$  dB or 50 dB, whichever is the lesser attenuation; (3) On any frequency removed from the center of the authorized bandwidth by more than 250 percent of the authorized bandwidth: At least  $43 + 10 \log (P)$  dB.

The occupied bandwidth was measured as shown below:

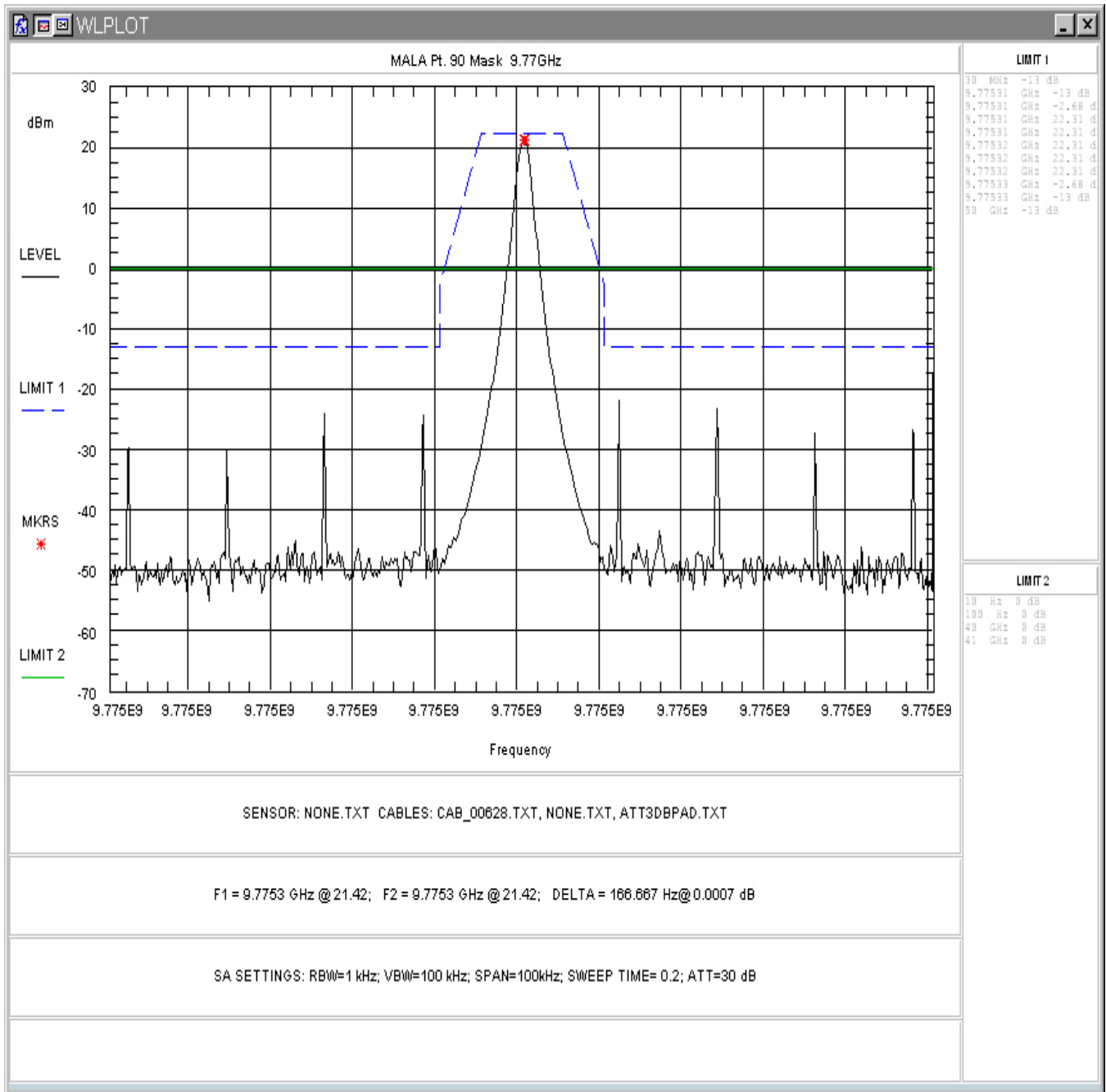

Figure 3: Occupied Bandwidth, Low Channel

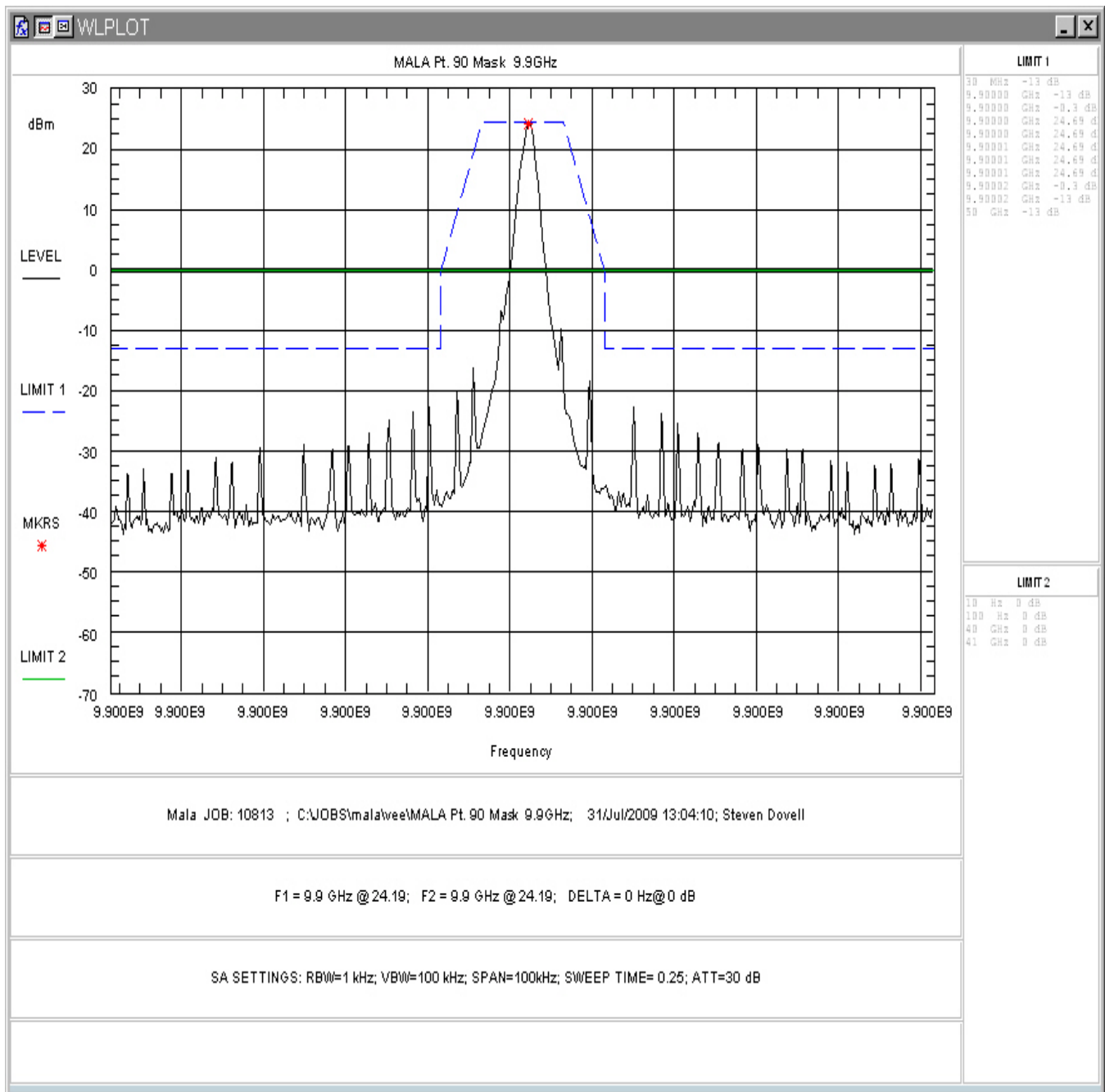

Figure 4: Occupied Bandwidth, Mid Channel



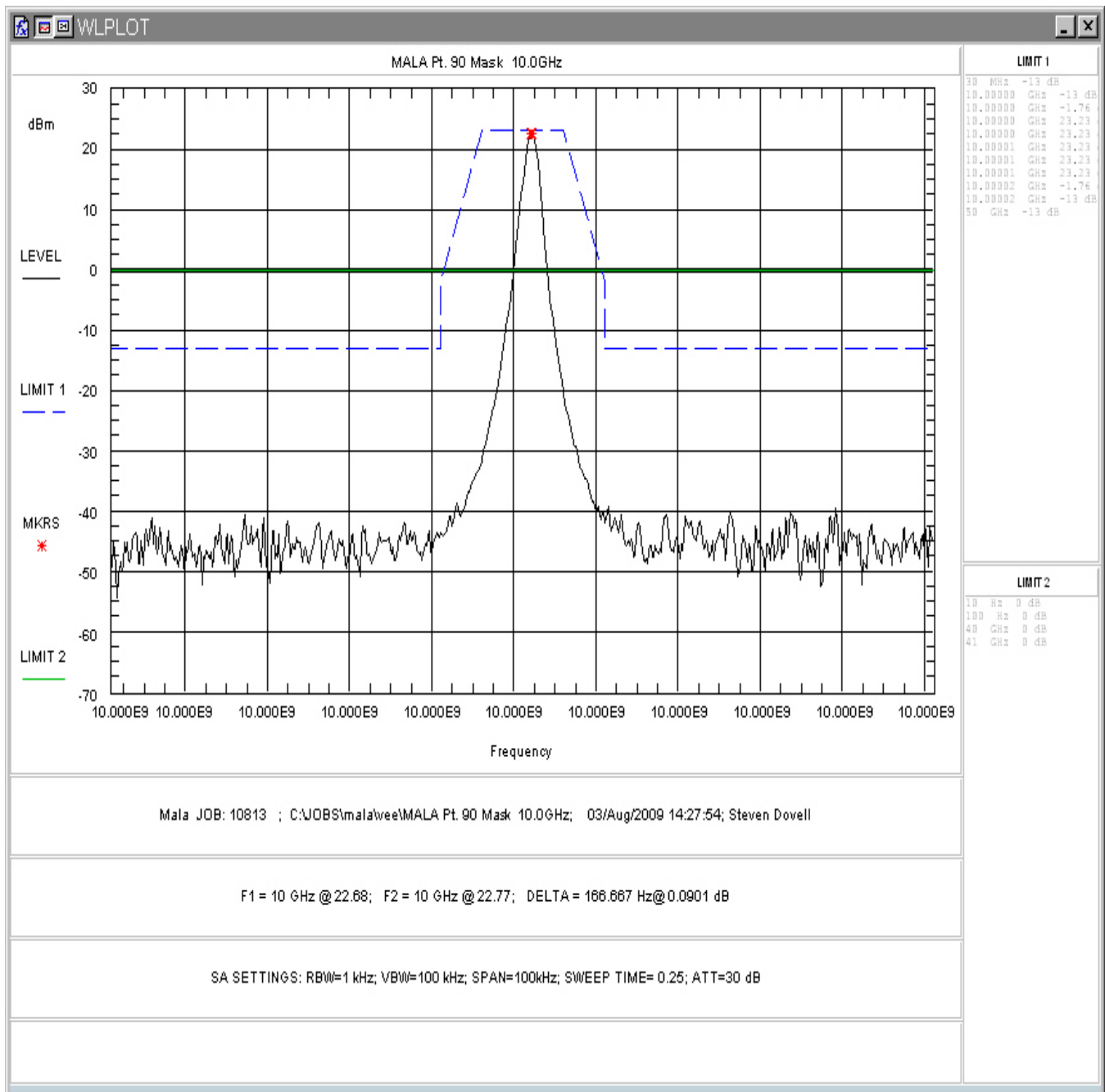

Figure 5: Occupied Bandwidth, High Channel

Table 4 provides a summary of the Occupied Bandwidth Results.

**Table 4: Occupied Bandwidth Results**

<b>Frequency</b>	<b>Bandwidth</b>	<b>Limit</b>	<b>Pass/Fail</b>
Low Channel 9.775GHz	CW	5kHz	Pass
Mid Channel 9.9GHz	CW	5kHz	Pass
High Channel 10.0GHz	CW	5kHz	Pass

### 4.3 Conducted Spurious Emissions at Antenna Terminals (FCC Part §2.1051)

FCC Part §90.210(c) states:

For transmitters that are not equipped with an audio low-pass filter, the power of any emission must be attenuated below the unmodulated carrier output power (P) as follows: (1) On any frequency removed from the center of the authorized bandwidth by a displacement frequency (fd in kHz) of more than 5 kHz, but not more than 10 kHz: At least  $83 \log (fd/5)$  dB; (2) On any frequency removed from the center of the authorized bandwidth by a displacement frequency (fd in kHz) of more than 10 kHz, but not more than 250 percent of the authorized bandwidth: At least  $29 \log (fd/11)$  dB or 50 dB, whichever is the lesser attenuation; (3) On any frequency removed from the center of the authorized bandwidth by more than 250 percent of the authorized bandwidth: At least  $43 + 10 \log (P)$  dB.

The EUT antenna was removed and the cable was connected directly into a spectrum analyzer through a 3 dB attenuator. An offset was programmed into the spectrum analyzer to compensate for the loss of the external attenuator and cables. The spectrum analyzer resolution bandwidth was set to 100 kHz and the video bandwidth was set to 1MHz. The amplitude of the EUT carrier frequency was measured to determine the emissions limit. The emissions outside of the allocated frequency band were then scanned from 30 MHz up to the tenth harmonic of the carrier (50GHz).

The following are plots of the conducted spurious emissions data.

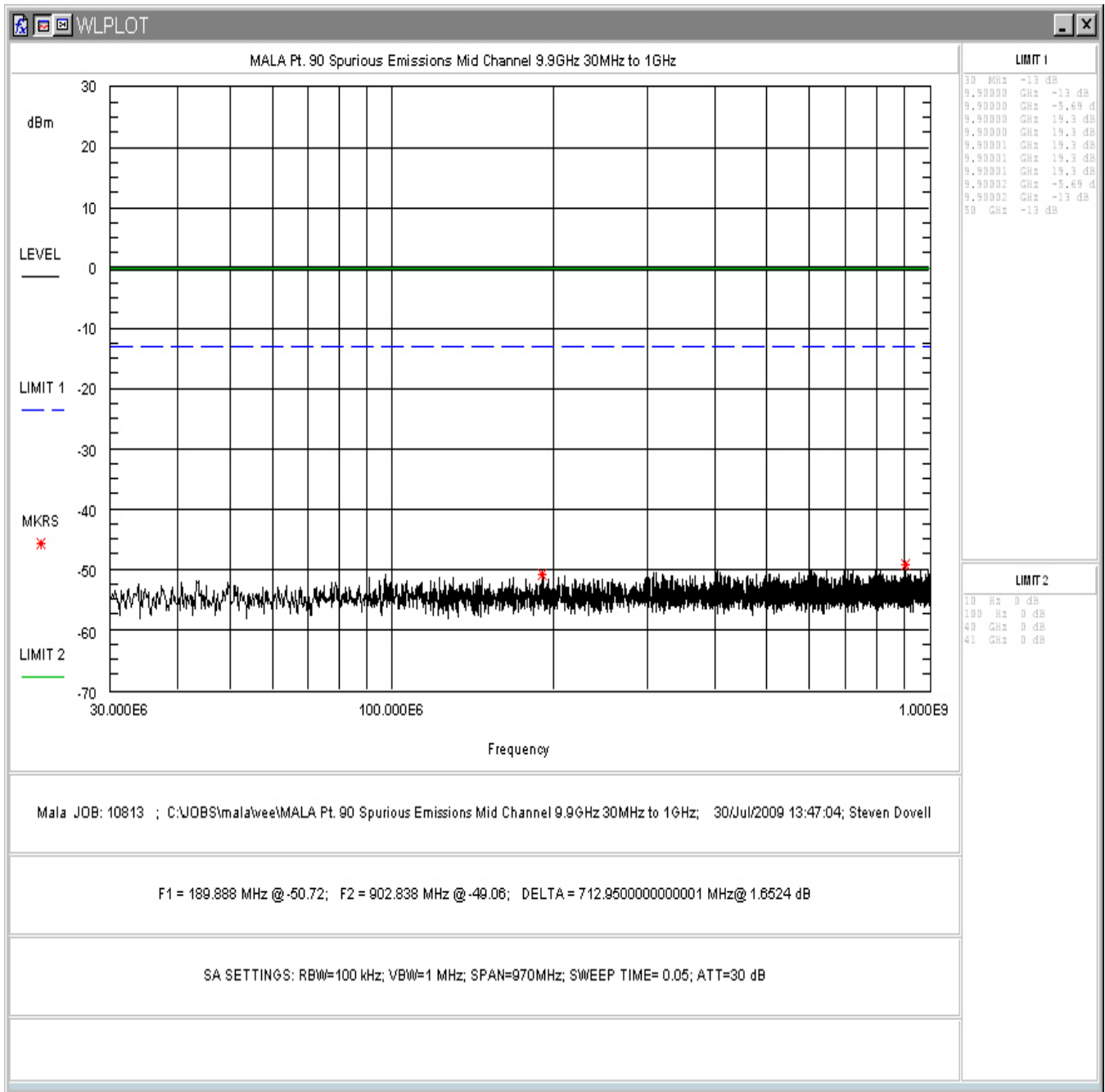

**Figure 6: Conducted Spurious Emissions, Center Channel 30 - 1000MHz**

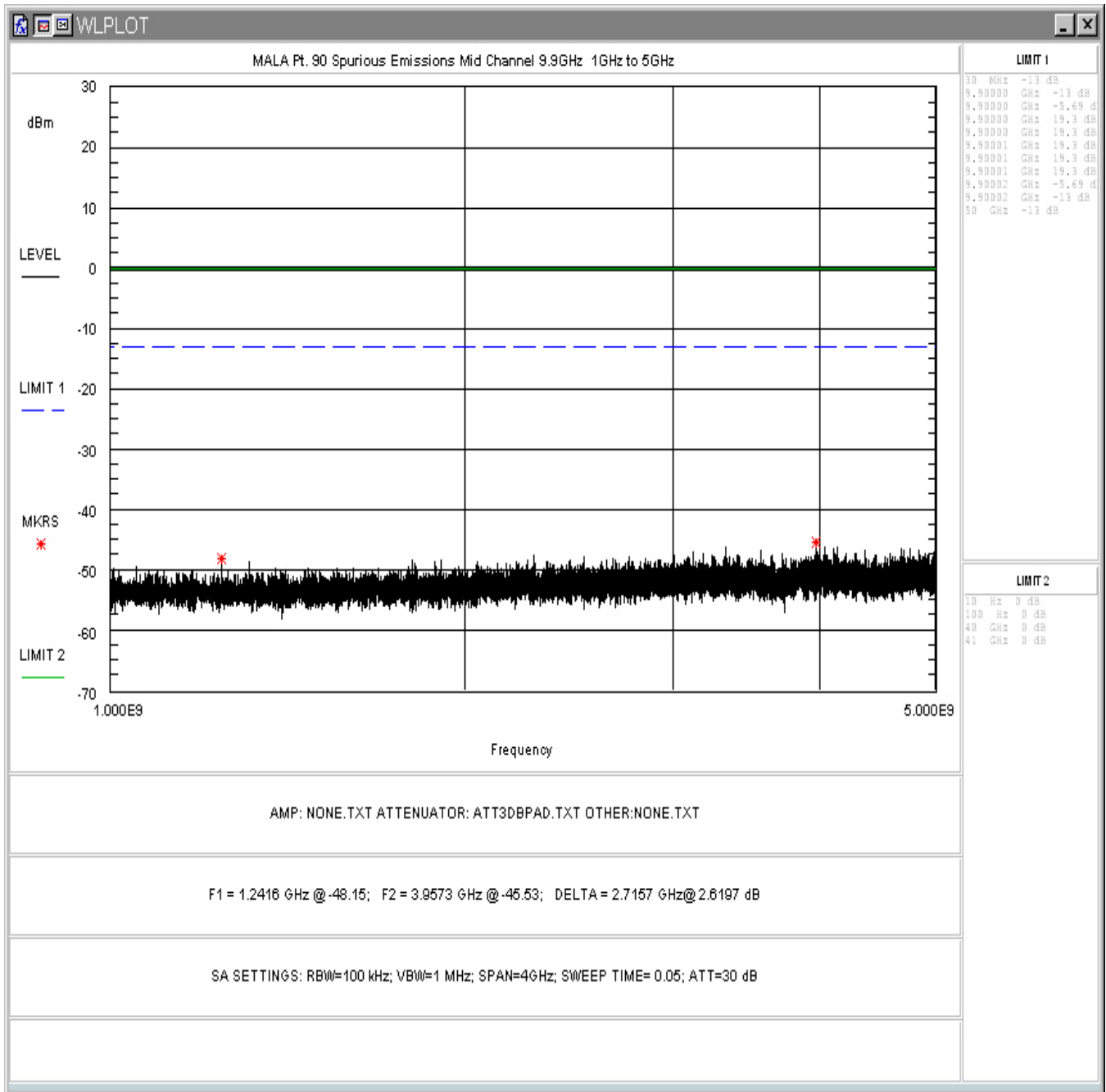

Figure 7: Conducted Spurious Emissions, Center Channel 1 – 5GHz

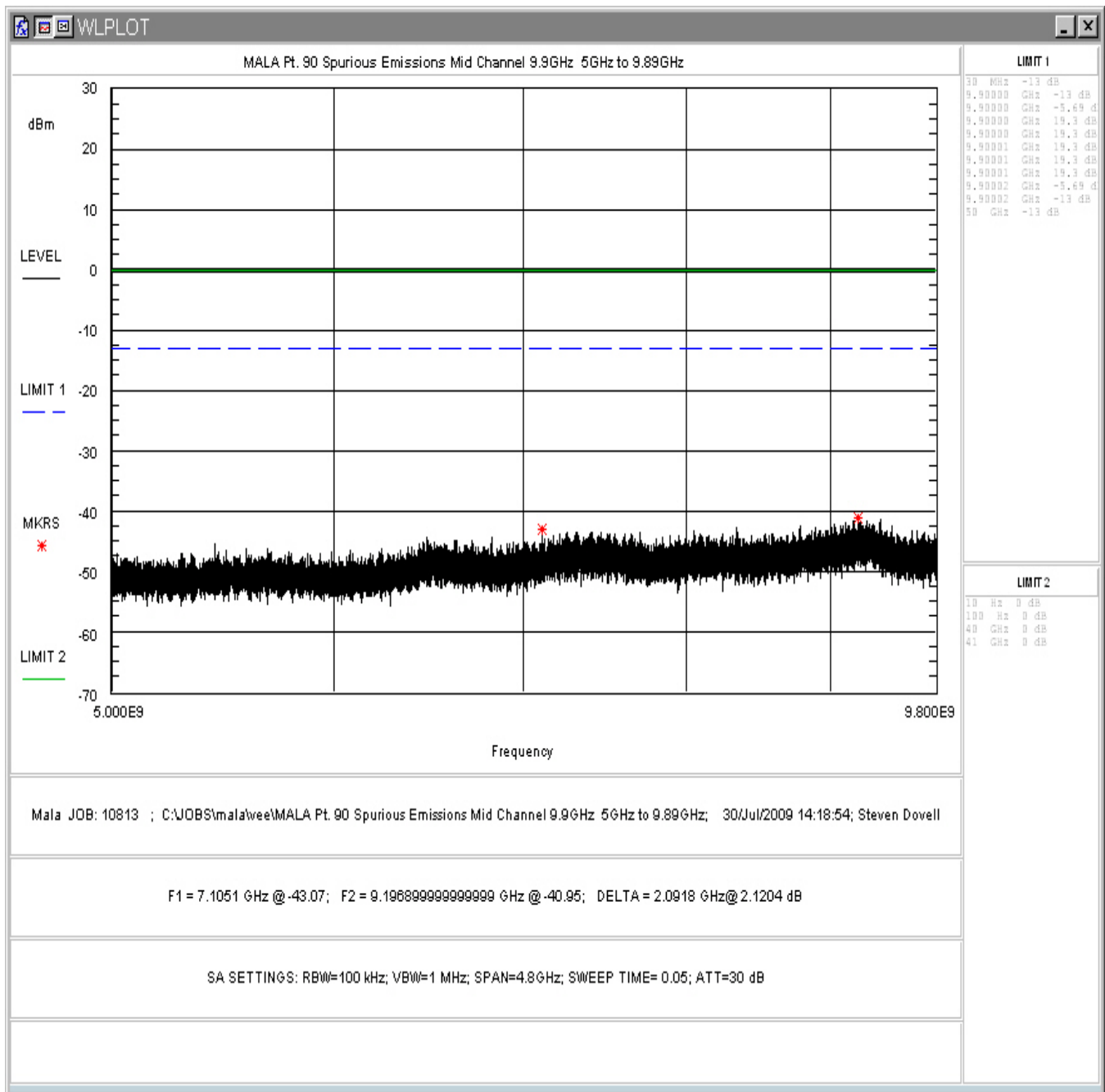
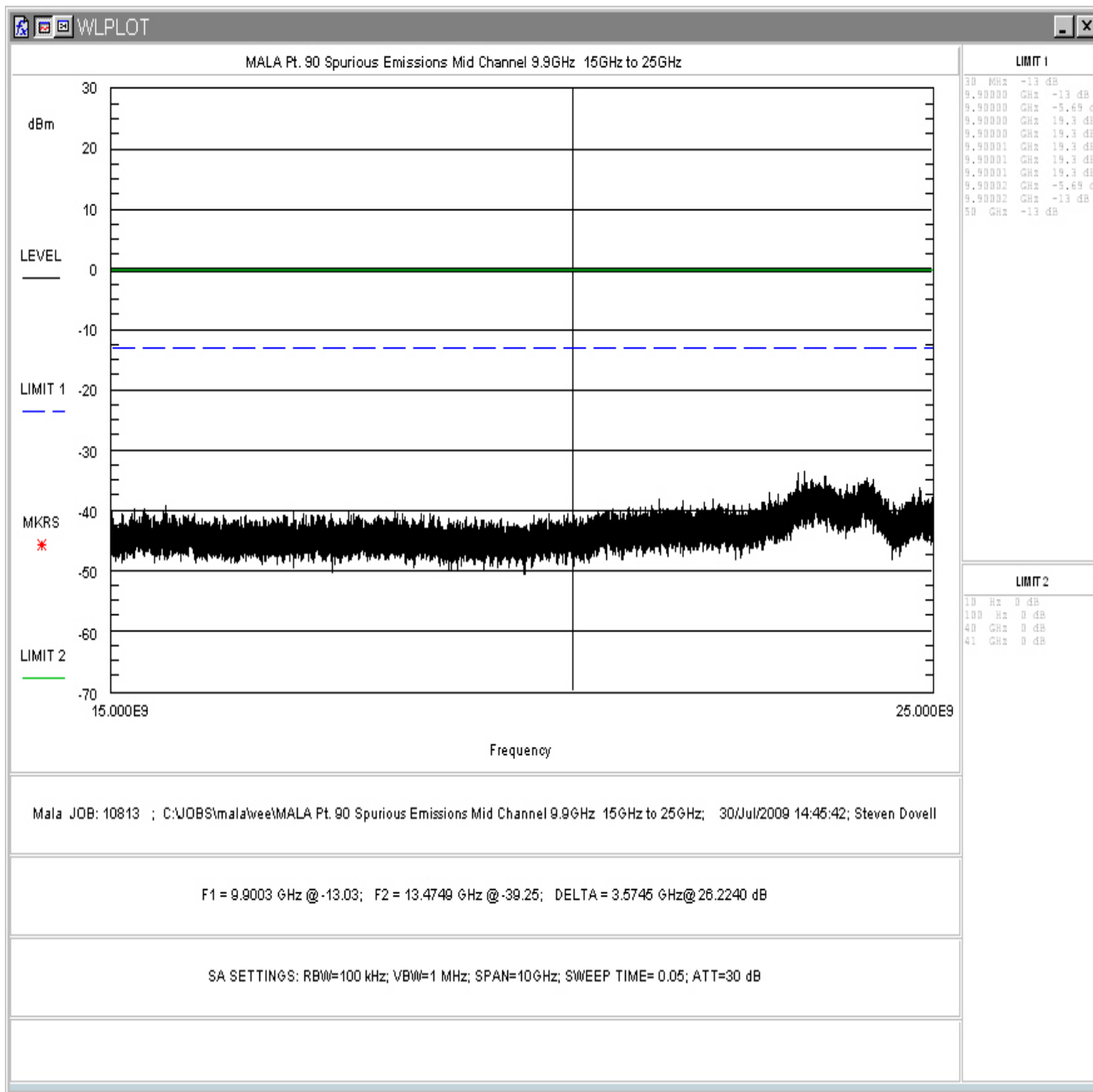

Figure 8: Conducted Spurious Emissions, Center Channel 5 – 9.8GHz



**Figure 9: Conducted Spurious Emissions, Center Channel 9.9 - 15GHz**

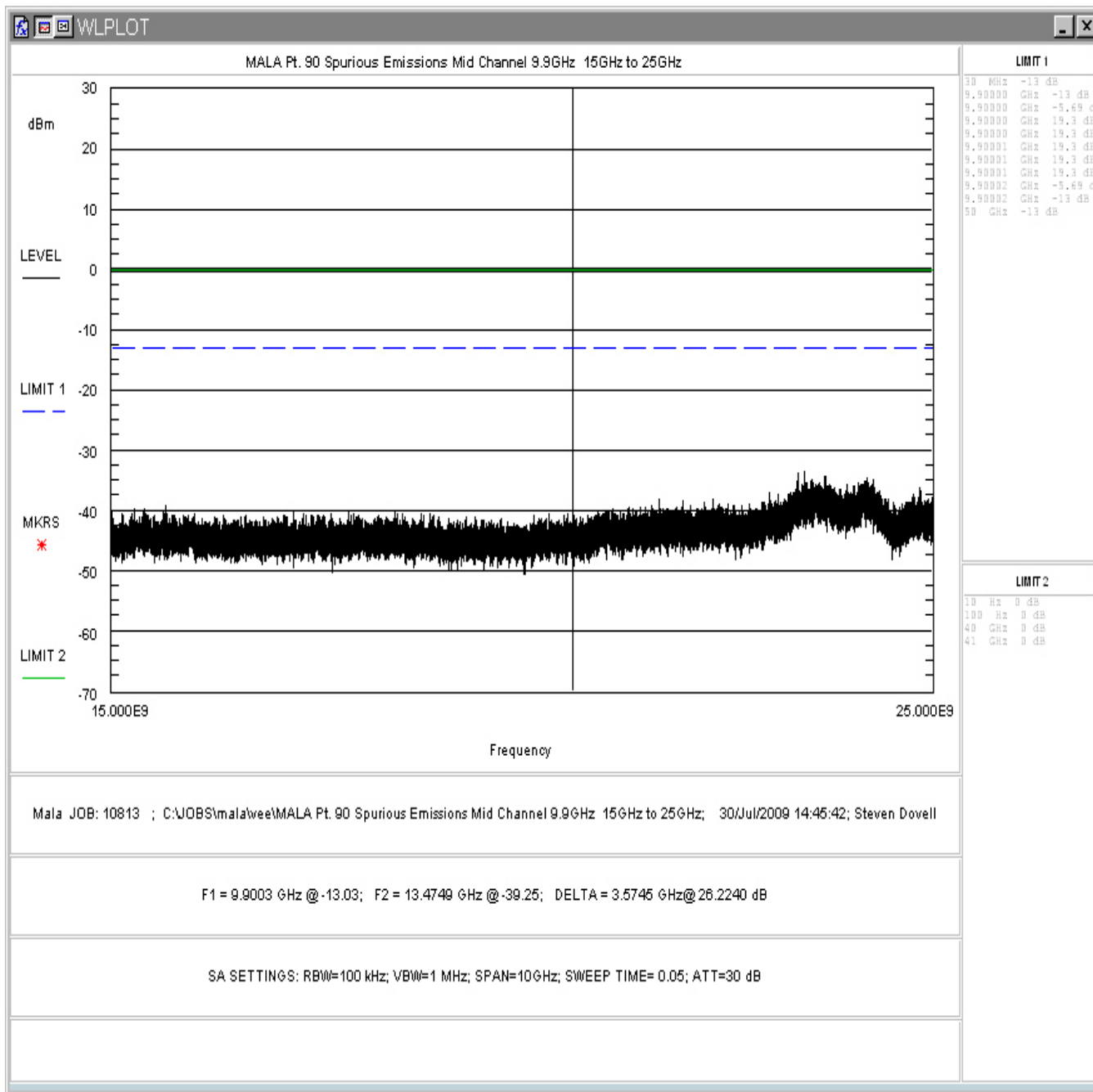

Figure 10: Conducted Spurious Emissions, Center Channel 15 - 25GHz

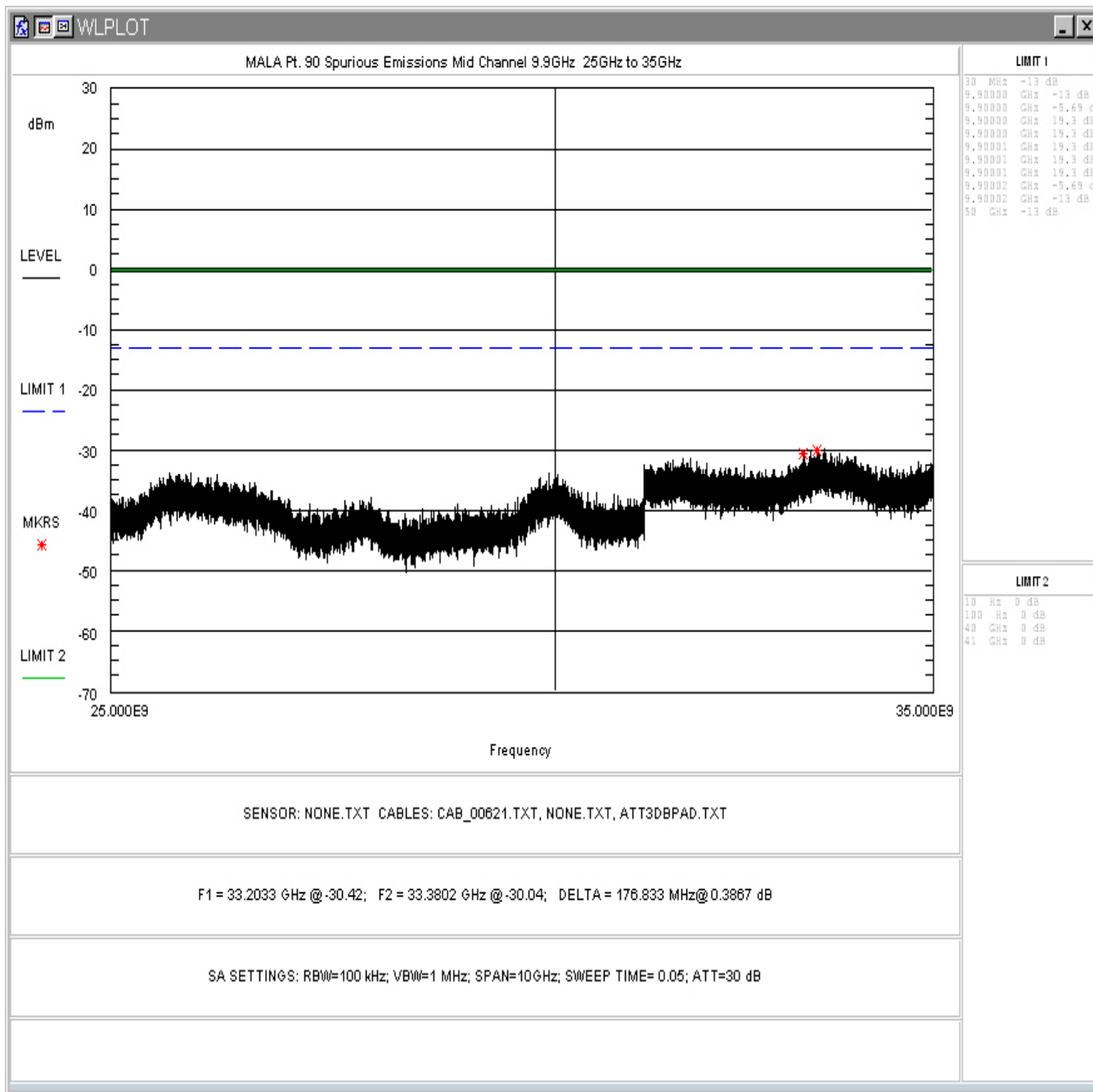
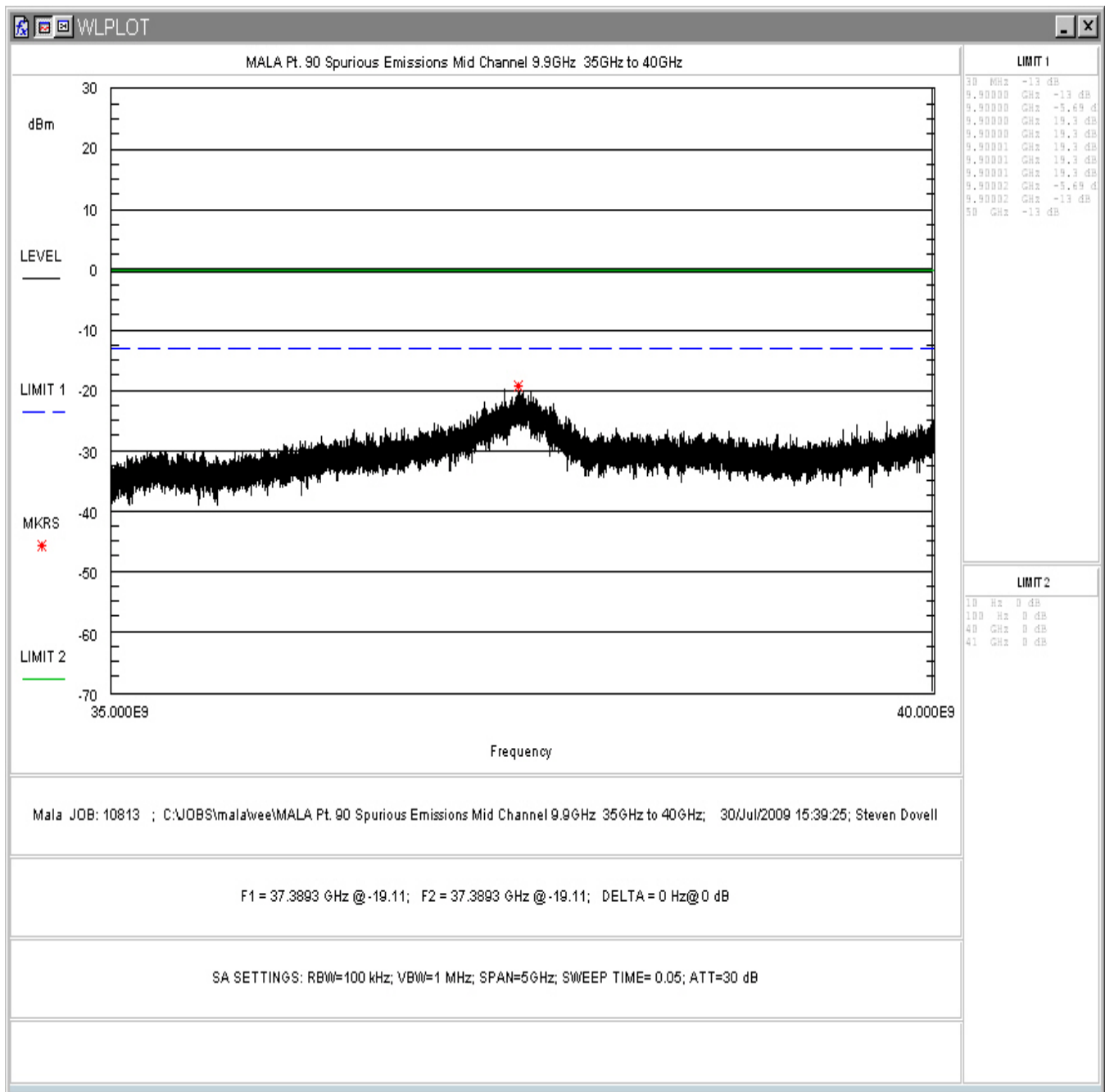

Figure 11: Conducted Spurious Emissions, Center Channel 25 - 35GHz





**Figure 12: Conducted Spurious Emissions, Center Channel 35 – 40GHz**

The EUT was examined from 40GHz – 50GHz using a Harmonic Mixer. No emissions were noted.

#### **4.4 Radiated Spurious Emissions: (FCC Part §2.1053)**

The EUT must comply with the requirements for radiated spurious emissions. These emissions must meet the limits specified in §90.210 (c) for peak measurements.

##### 4.4.1 Test Procedure

Due to the size of the EUT, the EUT was stationary and the antennas were moved around the EUT in approximately 22 degree arcs at a distance of 3-meter open field test site. The emissions from the EUT were measured and recorded. Both the horizontal and vertical field components were measured. The frequency range of 30MHz to 50GHz was examined.

Once all emissions were measured, a substitute antenna was used to transmit frequencies and levels that matched the EUT emissions and EIRP was determined. ERP was calculated by subtracting 2.15 from the EIRP results and compared to the limit of -13dBm. Test results are tabulated in Table 5.

**Table 5: Radiated Emission Test Data**

Frequency (MHz)	Polarity	Azimuth	Ant. Height (m)	Spurious Level (dBuV)	Sub. Sig. Gen. Level (dBm)	Sub. Power Level (dBm)	Sub. Ant. Factor (dB)	Sub. Ant. Gain (dB)	EIRP Level (dBm)	EIRP to ERP Conversion	Limit (dBm)	Margin (dB)
34.40	V	P1	1.0	49.3	-45.0	-46.9	10.9	-10.0	-56.9	-59.0	-13	-46.0
37.53	V	P1	1.0	51.0	-46.1	-48.0	10.5	-8.8	-56.8	-59.0	-13	-46.0
41.20	V	P1	1.0	53.5	-45.3	-47.3	10.4	-7.9	-55.2	-57.3	-13	-44.3
56.31	V	P2	1.0	46.5	-56.5	-58.5	10.9	-5.7	-64.2	-66.4	-13	-53.4
64.10	V	P2	1.0	46.3	-54.4	-56.4	10.2	-3.9	-60.2	-62.4	-13	-49.4
78.20	V	P2	1.0	45.7	-59.0	-60.8	6.6	1.4	-59.4	-61.6	-13	-48.6
90.63	V	P2	1.0	40.3	-64.5	-66.3	8.3	1.0	-65.2	-67.4	-13	-54.4
250.00	V	P1	1.5	43.0	-61.1	-63.8	12.7	5.5	-58.3	-60.4	-13	-47.4
380.12	V	P2	1.5	49.2	-53.4	-56.5	15.2	6.6	-49.9	-52.1	-13	-39.1
1002.00	V	P2	1.5	59.7	-40.6	-43.7	23.9	6.3	-37.4	-39.5	-13	-26.5
1125.25	v	P2	1.5	51.0	-48.5	-51.9	24.2	7.1	-44.8	-46.9	-13	-33.9
1237.70	v	P2	1.5	52.2	-47.7	-51.3	24.4	7.7	-43.6	-45.7	-13	-32.7
2338.65	V	P1	1.5	54.5	-41.8	-47.1	28.8	8.8	-38.3	-40.5	-13	-27.5
4950.20	V	P1	1.5	42.8	-50.0	-58.7	33.3	10.8	-47.9	-50.0	-13	-37.0
34.40	H	P2	1.5	39.0	-48.4	-50.3	10.9	-10.0	-60.3	-62.4	-13	-49.4
40.98	H	P2	1.5	43.2	-49.3	-51.3	10.4	-7.9	-59.2	-61.4	-13	-48.4
56.30	H	P2	1.5	57.0	-43.5	-45.5	10.9	-5.7	-51.2	-53.4	-13	-40.4
78.15	H	P2	1.5	55.4	-57.5	-59.3	6.6	1.4	-57.9	-60.1	-13	-47.1
87.53	H	P2	1.5	56.7	-53.3	-55.1	7.6	1.5	-53.6	-55.7	-13	-42.7
100.00	H	P2	1.5	46.0	-57.2	-58.9	12.6	-2.4	-61.3	-63.5	-13	-50.5
127.75	H	P1	1.5	47.5	-54.2	-56.2	13.1	-0.8	-56.9	-59.1	-13	-46.1
129.70	H	P2	1.5	49.0	-56.1	-58.1	13.1	-0.6	-58.7	-60.8	-13	-47.8
250.00	H	P2	1.5	48.4	-54.9	-57.6	12.7	5.5	-52.1	-54.2	-13	-41.2
380.12	H	P2	1.5	43.0	-67.6	-70.7	15.2	6.6	-64.1	-66.3	-13	-53.3
1002.00	H	P2	1.5	59.7	-39.8	-42.9	23.9	6.3	-36.6	-38.7	-13	-25.7
1125.25	H	P2	1.5	51.0	-50.4	-53.8	24.2	7.1	-46.7	-48.8	-13	-35.8
1237.70	H	P2	1.5	52.2	-47.8	-51.4	24.4	7.7	-43.7	-45.8	-13	-32.8
1250.00	H	P1	1.5	45.0	-57.5	-61.1	24.4	7.7	-53.3	-55.5	-13	-42.5
2333.30	H	P1	1.5	47.3	-50.3	-55.6	28.8	8.8	-46.8	-49.0	-13	-36.0

#### 4.5 Frequency Stability: (FCC Part §2.1055)

Frequency as a function of temperature and voltage variation shall be maintained within the FCC-prescribed tolerances.

The temperature stability was measured with the unit in an environmental chamber used to vary the temperature of the sample. The sample was held at each temperature step to allow the temperature of the sample to stabilize.

The EUT is powered by DC voltage supplied externally. The transceiver operates from 24VDC supplied via the control cable. The voltage connections were removed from the cable an external adjustable power supply was used to adjust the input voltage to the transceiver to 85% of the normal input voltage and 115% of the normal voltage. The frequency of the Center channel was measured and recorded at each voltage setting. Results are found in Table 7.

The frequency stability of the transmitter was examined for the temperature range of -30°C to +50°C. The carrier frequency was measured while the EUT was in the temperature chamber. The reference frequency of the EUT was measured at the ambient room temperature with the spectrum analyzer. The results are found in Table 6.

Frequency tolerance is specified by the station authority.

**Table 6: Frequency Deviation as a Function of Temperature**

<b>Temperature (Celsius)</b>	<b>Frequency (GHz)</b>	<b>Deviation (Hz)</b>
Center Channel	9.9	
-30	9.900011770.0	-280
-20	9.900012238.0	-748
-10	9.900012254.0	-764
0	9.900012193.0	-703
10	9.900011920.0	-430
20	9.900011490.0	0
30	9.900011471.0	19
40	9.900011300.0	190
50	9.900010860.0	630

**Table 7: Frequency Deviation as a Function of Voltage**

<b>Channel</b>	<b>Voltage (DC)</b>	<b>Frequency (GHz)</b>	<b>Deviation (Hz)</b>
Center Channel (9.9GHz)	20.4	9900011570.0	-80.0
	24	9900011490.0	0
	27.6	9900011491.0	1.0