



TEST REPORT

Test Report No. : UL-RPT-RP12039907-116A

Manufacturer : Datecs Ltd.
Model No. : SumUp Air
FCC ID : YRWSUMUPAIR
Technology : RFID – 13.56 MHz
Test Standard(s) : FCC Parts 15.207, 15.209(a) & 15.225

1. This test report shall not be reproduced except in full, without the written approval of UL VS LTD.
2. The results in this report apply only to the sample(s) tested.
3. The sample tested is in compliance with the above standard(s).
4. The test results in this report are traceable to the national or international standards.
5. Version 1.0

Date of Issue: 28 February 2020

Checked by:

Ben Mercer
Senior Test Engineer, Radio Laboratory

Company Signatory:

Sarah Williams
Senior Test Engineer, Radio Laboratory
UL VS LTD



This laboratory is accredited by UKAS.
The tests reported herein have been
performed in accordance with its terms
of accreditation.

UL VS LTD

Unit 1-3 Horizon, Wade Road, Kingsland Business Park, Basingstoke, Hampshire, RG24 8AH, UK
Telephone: +44 (0)1256 312000
Facsimile: +44 (0)1256 312001

This page has been left intentionally blank.

Table of Contents

1. Customer Information.....	4
2. Summary of Testing.....	5
2.1. General Information	5
2.2. Summary of Test Results	5
2.3. Methods and Procedures	5
2.4. Deviations from the Test Specification	5
3. Equipment Under Test (EUT)	6
3.1. Identification of Equipment Under Test (EUT)	6
3.2. Description of EUT	6
3.3. Modifications Incorporated in the EUT	6
3.4. Additional Information Related to Testing	7
3.5. Support Equipment	8
4. Operation and Monitoring of the EUT during Testing	9
4.1. Operating Modes	9
4.2. Configuration and Peripherals	9
5. Measurements, Examinations and Derived Results	10
5.1. General Comments	10
5.2. Test Results	11
5.2.1. Transmitter AC Conducted Spurious Emissions	11
5.2.2. Transmitter Fundamental Field Strength	17
5.2.3. Transmitter Radiated Spurious Emissions	21
5.2.4. Transmitter Band Edge Radiated Emissions	29
5.2.5. Transmitter 20 dB Bandwidth	32
5.2.6. Transmitter Frequency Stability (Temperature & Voltage Variation)	34
6. Measurement Uncertainty	37
7. Report Revision History	38
8. Appendix 1	39

1. Customer Information









Company Name:	Datecs Ltd
Address:	Datecs Street No 4 Sofia 1592 Bulgaria

2. Summary of Testing

2.1. General Information

Specification Reference:	47CFR15.225
Specification Title:	Code of Federal Regulations Volume 47 (Telecommunications): Part 15 Subpart C (Radio Frequency Devices) - Section 15.225
Specification Reference:	47CFR15.207 and 47CFR15.209
Specification Title:	Code of Federal Regulations Volume 47 (Telecommunications): Part 15 Subpart C (Intentional Radiators) - Sections 15.207 and 15.209
Site Registration:	621311
Location of Testing:	UL VS LTD, Unit 3 Horizon, Wade Road, Kingsland Business Park, Basingstoke, Hampshire, RG24 8AH, United Kingdom
Test Dates:	18 November 2019 to 30 November 2019

2.2. Summary of Test Results

FCC Reference (47CFR)	Measurement	Result
Part 15.207	Transmitter AC Conducted Emissions	
Part 15.225(a)(b)(c)(d)	Transmitter Fundamental Field Strength	
Part 15.209(a)/15.225(d)	Transmitter Radiated Emissions	
Part 15.209(a)/15.225(c)(d)	Transmitter Band Edge Radiated Emissions	
Part 2.1049	Transmitter 20 dB Bandwidth	
Part 15.225(e)	Transmitter Frequency Stability (Temperature & Voltage Variation)	
Key to Results		
 = Complied  = Did not comply		

2.3. Methods and Procedures

Reference:	ANSI C63.10-2013
Title:	American National Standard of Procedures for Compliance Testing of Unlicensed Wireless Devices
Reference:	KDB 414788 D01 Radiated Test Site v01r01 July 12, 2018
Title:	Test Site For Radiated Emission Measurements
Reference:	KDB 174176 D01 Line Conducted FAQ v01r01 June 3, 2015
Title:	AC Power-Line Conducted Emissions Frequently Asked Questions

2.4. Deviations from the Test Specification

For the measurements contained within this test report, there were no deviations from, additions to, or exclusions from the test specification identified above.

3. Equipment Under Test (EUT)

3.1. Identification of Equipment Under Test (EUT)

Brand Name:	SumUp
Model Name or Number:	SumUp Air
Test Sample Serial Number:	105118000026 (<i>Radiated sample #1</i>)
Hardware Version:	AIR1E205
Software Version:	03.00.19.17
FCC ID:	YRWSUMUPAIR

Brand Name:	SumUp
Model Name or Number:	SumUp Air
Test Sample Serial Number:	105118000009 (<i>Radiated sample #2</i>)
Hardware Version:	AIR1E205
Software Version:	03.00.19.17
FCC ID:	YRWSUMUPAIR

Brand Name:	SumUp
Model Name or Number:	SumUp Air
Test Sample Serial Number:	105118000025 (<i>Sample with dummy load on antenna port</i>)
Hardware Version:	AIR1E205
Software Version:	03.00.19.17
FCC ID:	YRWSUMUPAIR

3.2. Description of EUT

The equipment under test was a mobile payment terminal with magnetic card reader, contactless card reader and smart card reader. The EUT incorporated a Bluetooth Low Energy module (FCC ID: RYYEYSHCN) and 13.56 MHz NFC functionality.

3.3. Modifications Incorporated in the EUT

A Würth Elektronik 742 711 11 ferrite was fitted to the 0.4 m USB cable. This was used for all testing. No other modifications were applied to the EUT during testing.

3.4. Additional Information Related to Testing

Tested Technology:	RFID	
Category of Equipment:	Transceiver	
Channel Spacing:	Single channel device	
Transmit Frequency Range:	13.56 MHz	
Power Supply Requirement:	Nominal	3.7 VDC
	Minimum	3.6 VDC
	Maximum	4.2 VDC
Tested Temperature Range:	Minimum	-20°C
	Maximum	50°C

3.5. Support Equipment

The following support equipment was used to exercise the EUT during testing:

Description:	Contactless Credit Card
Brand Name:	Not marked or stated
Model Name or Number:	Not marked or stated
Serial Number:	Not marked or stated

Description:	Laptop PC
Brand Name:	Lenovo
Model Name or Number:	Think Pad L440
Serial Number:	R9-019EA1

Description:	Micro Type B to Type A USB Cable. Quantity 1. Length 0.4 m
Brand Name:	Not marked or stated
Model Name or Number:	Not marked or stated
Serial Number:	Not marked or stated

Description:	USB Extension Cable. Quantity 2. Length 1 m
Brand Name:	Not marked or stated
Model Name or Number:	Not marked or stated
Serial Number:	Not marked or stated

Description:	USB Extension Cable. Quantity 1. Length 8 m
Brand Name:	Not marked or stated
Model Name or Number:	Not marked or stated
Serial Number:	Not marked or stated

Description:	AC to DC Adapter
Brand Name:	Lenovo
Model Name or Number:	ADLX65NDC3A
Serial Number:	Not marked or stated

4. Operation and Monitoring of the EUT during Testing

4.1. Operating Modes

The EUT was tested in the following operating mode(s):

- Constantly transmitting at full power with a modulated carrier in RFID test mode.

4.2. Configuration and Peripherals

The EUT was tested in the following configuration(s):

- The EUT had test firmware installed that would transmit once powered up. The customer supplied a setup instruction document: '*Instruction how to start NFC and BT tests.pdf SumUp TEST.pdf_16/08/2019*'.
- Radiated emissions measurements: pre-scans were initially performed with the EUT in X/Y/Z orientation while the EUT was connected to a laptop PC. For measurements in a semi-anechoic chamber, the laptop was placed outside of the chamber. All final measurements were performed in the worst case orientation for emissions.
- All measurements were performed with or without a contactless card to identify if the use of the card and/or the placement of it produced the worst case results for that particular test. Testing was performed with the card placed on the EUT display, near the EUT while maintaining contact or with no card present. The worst case combination and the orientation of the EUT for each test case and/or frequency is stated below:
 - AC Conducted Emissions: The worst case was with no card present.
 - Fundamental Field Strength: Testing was performed with a card present while maintaining contact and with no card present.
 - Radiated Band Edge: Testing was performed with a card present while maintaining contact and with no card present.
 - 20 dB Bandwidth: Testing was performed with a card present while maintaining contact and with no card present.
 - Transmitter Radiated Emissions:
 - <30 MHz: EUT in the Y Axis (vertically positioned) with no card present.
 - >30 MHz: EUT in the Z Axis (laying on its back) with the card placed on the display of the EUT.
 - Transmitter Frequency Stability: With no card present.

For all in band radiated measurements the EUT was placed in the Y Axis (vertically positioned).

- The customer declared that the MSR (Magstripe Card Reader) card slot is not an active port. All other ports were populated.
- Testing at voltage extremes was performed with an external DC power supply connected to the EUT.
- Refer to Appendix 1 of this test report for details of radiated tests on an open field test site.

5. Measurements, Examinations and Derived Results

5.1. General Comments

Measurement uncertainties are evaluated in accordance with current best practice. Our reported expanded uncertainties are based on standard uncertainties, which are multiplied by an appropriate coverage factor to provide a statistical confidence level of approximately 95%. Please refer to *Section 6: Measurement Uncertainties* for details.

In accordance with UKAS requirements all the measurement equipment is on a calibration schedule. All equipment was within the calibration period on the date of testing.

5.2. Test Results

5.2.1. Transmitter AC Conducted Spurious Emissions

Test Summary:

Test Engineer:	Alison Johnston	Test Date:	30 November 2019
Test Sample Serial Number:	105118000009 & 105118000025		

FCC Reference:	Part 15.207
Test Method Used:	ANSI C63.10 Section 6.2 / FCC KDB 174176 and Notes below

Environmental Conditions:

Temperature (°C):	23
Relative Humidity (%):	43

Note(s):

1. The EUT was connected to a laptop PC via a USB cable. The laptop AC to DC adaptor was connected to a 120 VAC 60 Hz single phase supply via a LISN.
2. In accordance with FCC KDB 174176 Q4, tests were also performed with a 240 VAC 60 Hz single phase supply as this was within the voltage range marked on the AC to DC adapter.
3. The EUT was initially tested with the standard antenna connected (test sample serial number 105118000009). An emission at the approximate carrier frequency of 13.56 MHz was found to be non-compliant as it exceeded the test limit. The customer supplied a modified sample (test sample serial number 105118000025) with the standard antenna disconnected and a dummy load fitted in accordance with FCC KDB 174176 Q5. The test was repeated and the EUT was found to be compliant.
4. * Test results with standard EUT sample (standard antenna).
5. ** Test results with EUT sample incorporating antenna dummy load.
6. A pulse limiter was fitted between the LISN and the test receiver.
7. Pre-scans were performed and markers placed on the highest live and neutral measured levels. Final measurements were performed on the marker frequencies and the highest six emissions were recorded in the tables below.

Test setup:

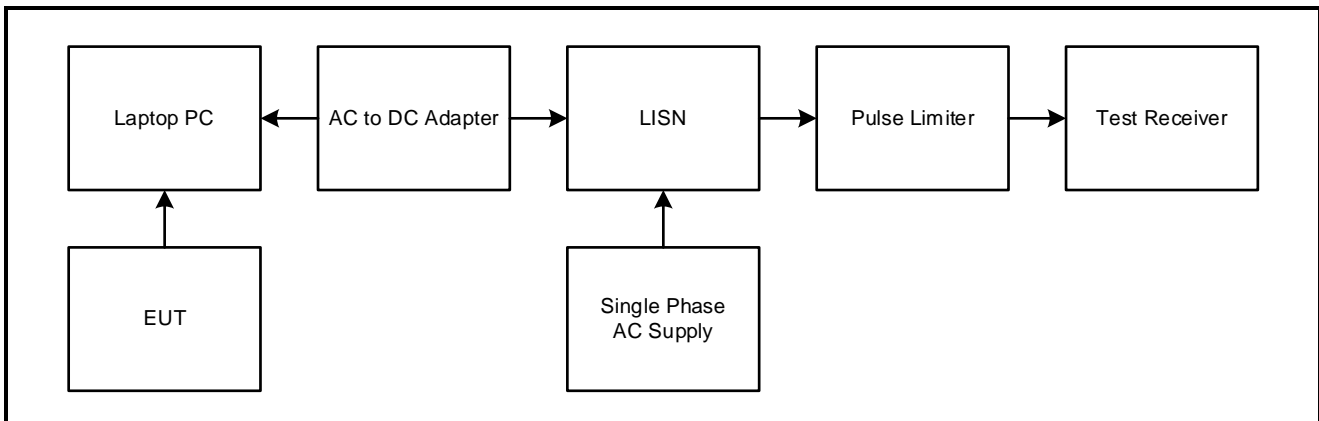

Transmitter AC Conducted Spurious Emissions (continued)**Results: Live / Quasi Peak / 120 VAC 60 Hz**

Frequency (MHz)	Line	Level (dB μ V)	Limit (dB μ V)	Margin (dB)	Result
0.150	Live	59.8*	66.0	6.2	Complied
0.182	Live	55.1*	64.4	9.3	Complied
0.267	Live	49.1*	61.2	12.1	Complied
1.545	Live	35.3*	56.0	20.7	Complied
3.521	Live	34.1*	56.0	21.9	Complied
13.560	Live	43.9**	60.0	16.1	Complied

Results: Live / Average / 120 VAC 60 Hz

Frequency (MHz)	Line	Level (dB μ V)	Limit (dB μ V)	Margin (dB)	Result
0.164	Live	46.3*	55.3	9.0	Complied
0.218	Live	40.6*	52.9	12.3	Complied
0.272	Live	33.5*	51.1	17.6	Complied
1.316	Live	27.2*	46.0	18.8	Complied
3.422	Live	23.1*	46.0	22.9	Complied
13.560	Live	43.6**	50.0	6.4	Complied

Results: Neutral / Quasi Peak / 120 VAC 60 Hz

Frequency (MHz)	Line	Level (dB μ V)	Limit (dB μ V)	Margin (dB)	Result
0.150	Neutral	60.4*	66.0	5.6	Complied
0.195	Neutral	45.2*	63.8	18.6	Complied
0.267	Neutral	44.4*	61.2	16.8	Complied
1.671	Neutral	35.1*	56.0	20.9	Complied
4.893	Neutral	34.7*	56.0	21.3	Complied
13.560	Neutral	43.0**	60.0	17.0	Complied

Results: Neutral / Average / 120 VAC 60 Hz

Frequency (MHz)	Line	Level (dB μ V)	Limit (dB μ V)	Margin (dB)	Result
0.164	Neutral	45.0*	55.3	10.3	Complied
0.222	Neutral	36.0*	52.7	16.7	Complied
0.501	Neutral	26.2*	46.0	19.8	Complied
0.893	Neutral	27.8*	46.0	18.2	Complied
2.850	Neutral	25.6*	46.0	20.4	Complied
13.560	Neutral	42.8**	50.0	7.2	Complied

Transmitter AC Conducted Spurious Emissions (continued)

Results: 120 VAC 60 Hz with unmodified sample (antenna present)

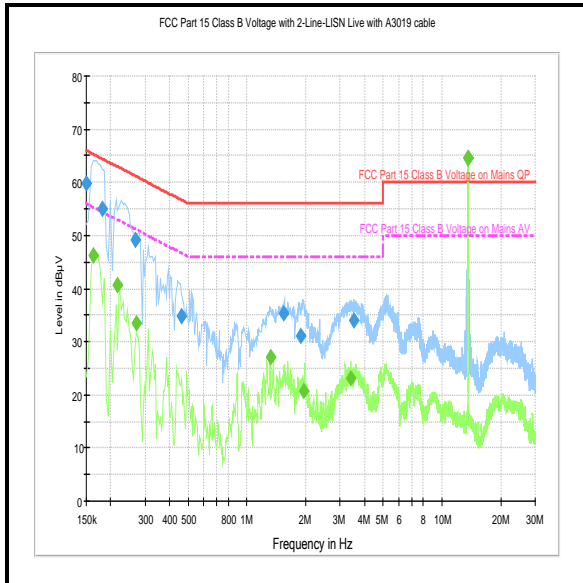

Live

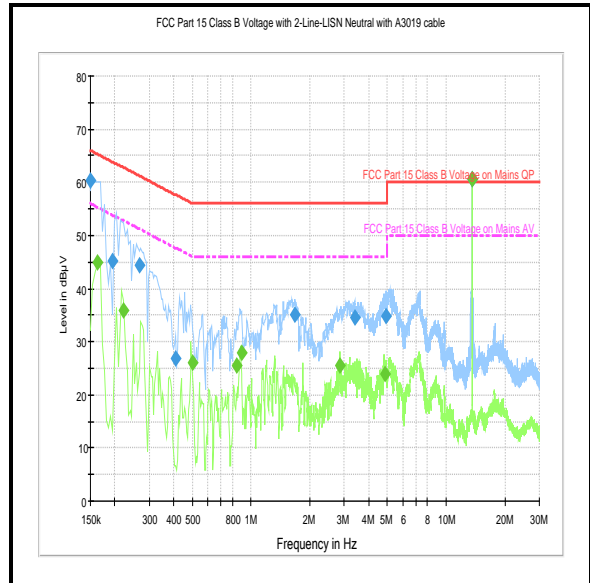

Neutral

Results: 120 VAC 60 Hz with modified sample (transmitter terminated into a dummy load)

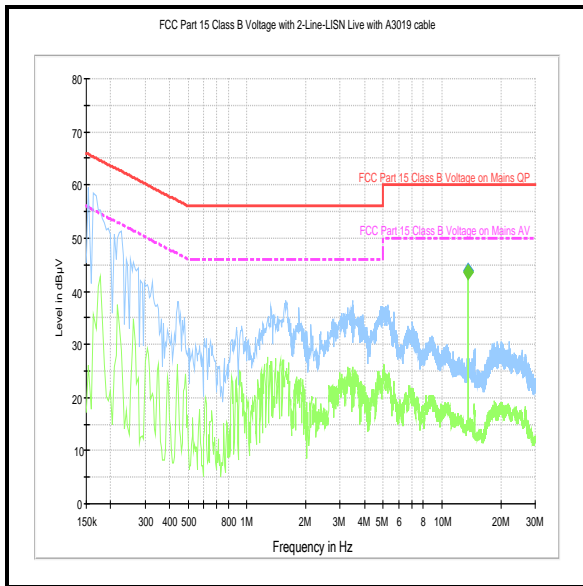

Live

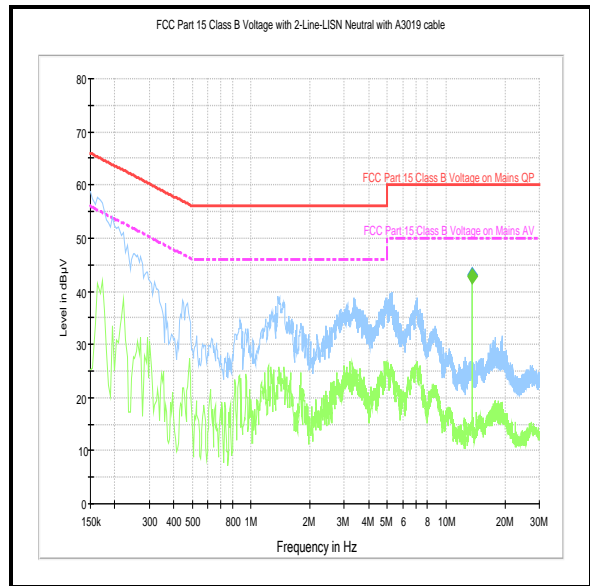

Neutral

Note: These plots are pre-scans and for indication purposes only. For final measurements, see accompanying tables.

Transmitter AC Conducted Spurious Emissions (continued)**Results: Live / Quasi Peak / 240 VAC 60 Hz**

Frequency (MHz)	Line	Level (dB μ V)	Limit (dB μ V)	Margin (dB)	Result
0.150	Live	52.2*	66.0	13.8	Complied
0.182	Live	48.2*	64.4	16.2	Complied
0.488	Live	36.3*	56.2	19.9	Complied
3.210	Live	35.4*	56.0	20.6	Complied
3.777	Live	37.2*	56.0	18.8	Complied
13.560	Live	43.7**	60.0	16.3	Complied

Results: Live / Average / 240 VAC 60 Hz

Frequency (MHz)	Line	Level (dB μ V)	Limit (dB μ V)	Margin (dB)	Result
0.164	Live	41.8*	55.3	13.5	Complied
0.942	Live	30.3*	46.0	15.7	Complied
1.365	Live	33.1*	46.0	12.9	Complied
3.120	Live	29.7*	46.0	16.3	Complied
3.606	Live	29.1*	46.0	16.9	Complied
13.560	Live	43.5**	50.0	6.5	Complied

Results: Neutral / Quasi Peak / 240 VAC 60 Hz

Frequency (MHz)	Line	Level (dB μ V)	Limit (dB μ V)	Margin (dB)	Result
0.159	Neutral	52.9*	65.5	12.6	Complied
0.186	Neutral	49.7*	64.2	14.5	Complied
0.308	Neutral	38.5*	60.0	21.5	Complied
1.415	Neutral	34.2*	56.0	21.8	Complied
3.323	Neutral	36.3*	56.0	19.7	Complied
13.560	Neutral	43.0**	60.0	17.0	Complied

Results: Neutral / Average / 240 VAC 60 Hz

Frequency (MHz)	Line	Level (dB μ V)	Limit (dB μ V)	Margin (dB)	Result
0.159	Neutral	38.7*	55.5	16.8	Complied
0.186	Neutral	36.0*	54.2	18.2	Complied
1.365	Neutral	27.9*	46.0	18.1	Complied
3.129	Neutral	28.8*	46.0	17.2	Complied
3.579	Neutral	26.4*	46.0	19.6	Complied
13.560	Neutral	42.6**	50.0	7.4	Complied

Transmitter AC Conducted Spurious Emissions (continued)

Results: 240 VAC 60 Hz with unmodified sample (antenna present)

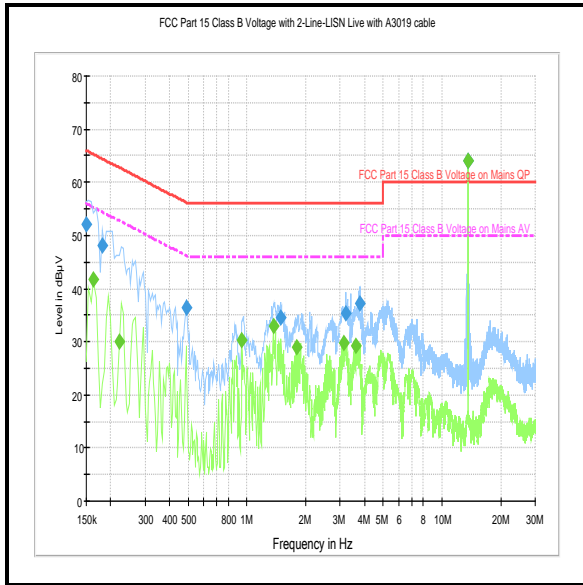

Live

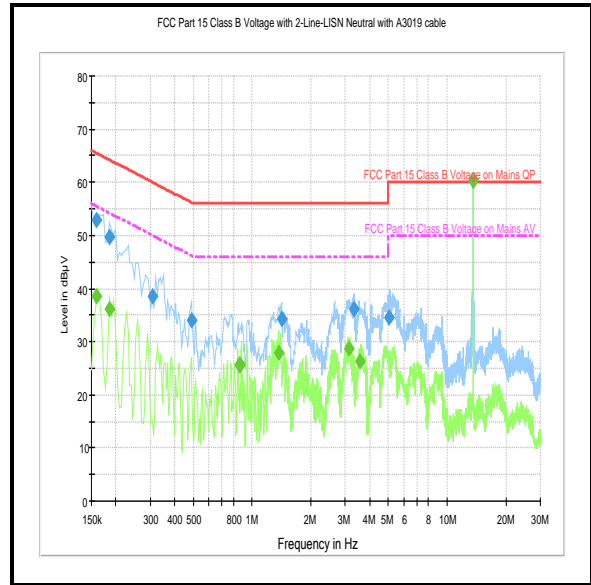

Neutral

Results: 240 VAC 60 Hz with modified sample (transmitter terminated into a dummy load)

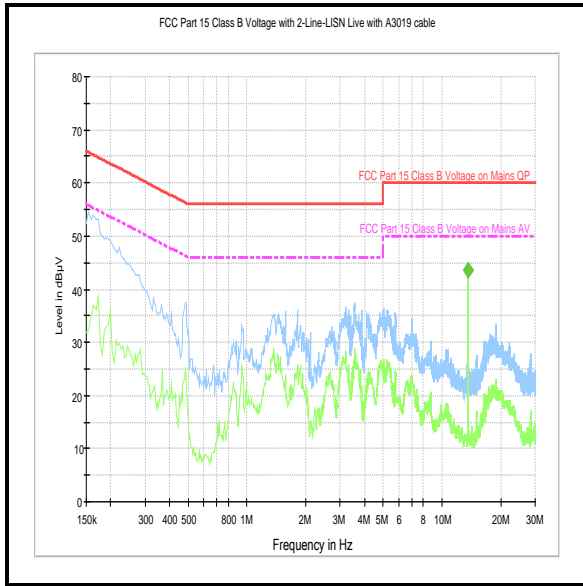

Live

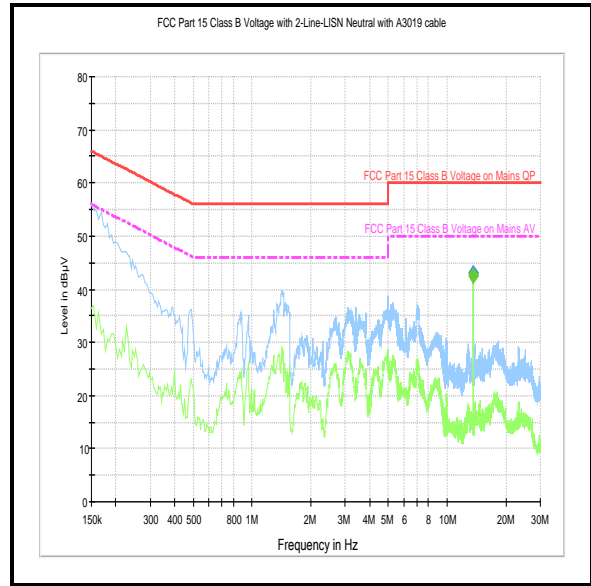

Neutral

Note: These plots are pre-scans and for indication purposes only. For final measurements, see accompanying tables.

Transmitter AC Conducted Spurious Emissions (continued)**Test Equipment Used:**

Asset No.	Instrument	Manufacturer	Type No.	Serial No.	Date Calibration Due	Cal. Interval (Months)
M2037	Thermohygrometer	Testo	608-H1	45124925	06 Jan 2020	12
M1124	Test Receiver	Rohde & Schwarz	ESIB 26	100046	11 Oct 2020	12
A649	LISN	Rohde & Schwarz	ESH3-Z5	825562/008	08 Aug 2020	12
A1830	Pulse Limiter	Rohde & Schwarz	ESH3-Z2	100668	10 Apr 2020	12
M1269	Multimeter	Fluke	179	90250210	17 Apr 2020	12
A2953	Variable AC Power Supply	Tacima	SC 5467	Not stated	Calibrated before use	-

Test Measurement Software/Firmware Used:

Name	Version	Release Date
Rohde & Schwarz EMC32	6.30.0	2008

5.2.2. Transmitter Fundamental Field Strength**Test Summary:**

Test Engineers:	Andrew Edwards & Nick Tye	Test Dates:	19 November 2019 & 21 November 2019
Test Sample Serial Number:	105118000026		

FCC Reference:	Part 15.225(a)(b)(c)(d)
Test Method Used:	ANSI C63.10 Section 6.4 and Notes below

Environmental Conditions:

Temperature (°C):	6 to 21
Relative Humidity (%):	36 to 78

Note(s):

1. In accordance with FCC KDB 414788, a *bona fide* attempt was made to perform measurements at the distances specified in Part 15.209(a). The fundamental was measured at 30 metres on an open field test site using a measurement bandwidth of 10 kHz on 19 November 2019. Background scans of the open field test site can be found in Appendix 1 of this test report for further information.
2. Pre-scan measurements were performed in the semi-anechoic chamber using a test receiver in spectrum analyser mode with a peak detector and measurement bandwidth of 10 kHz, the fundamental field strength was maximized by rotating the measurement antenna and EUT. The peak level was recorded at a measurement distance of 3 metres. The spectrum analyser was then switched to test receiver mode and the final measurement on the maximized level was performed. In accordance with ANSI C63.10 Clause 4.1.4.2.1 and CISPR 16-1-1, a quasi-peak detector was used in conjunction with a measurement bandwidth of 9 kHz and 0.2 second sweep time. The quasi-peak level was recorded in the table below
3. The level of the transmitter fundamental field strength at 3 metres in the semi-anechoic chamber, with reference to the open field test site, is used to show compliance to the limit.
4. A transducer factor was used on the spectrum analyser during open field tests. This factor includes correction between the fixed gain of the magnetic loop antenna and the calibration values. It also includes the insertion loss of the RF cable used to connect the antenna to the spectrum analyser which was incorporated into the annual calibration of the magnetic loop antenna.

Transmitter Fundamental Field Strength (continued)

Test setup for fundamental field strength measurements test set up:

Measurements below 30 MHz on an Open Field Test Site

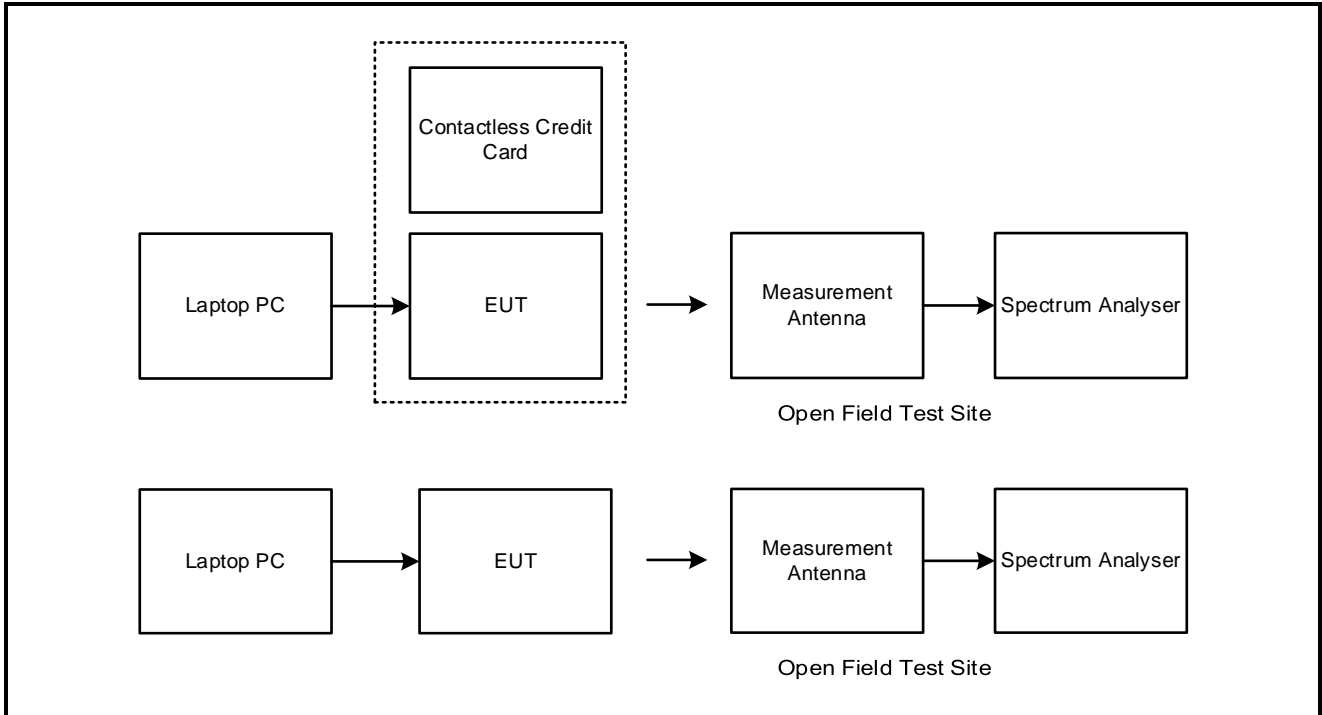

Measurements below 30 MHz in a semi-anechoic chamber

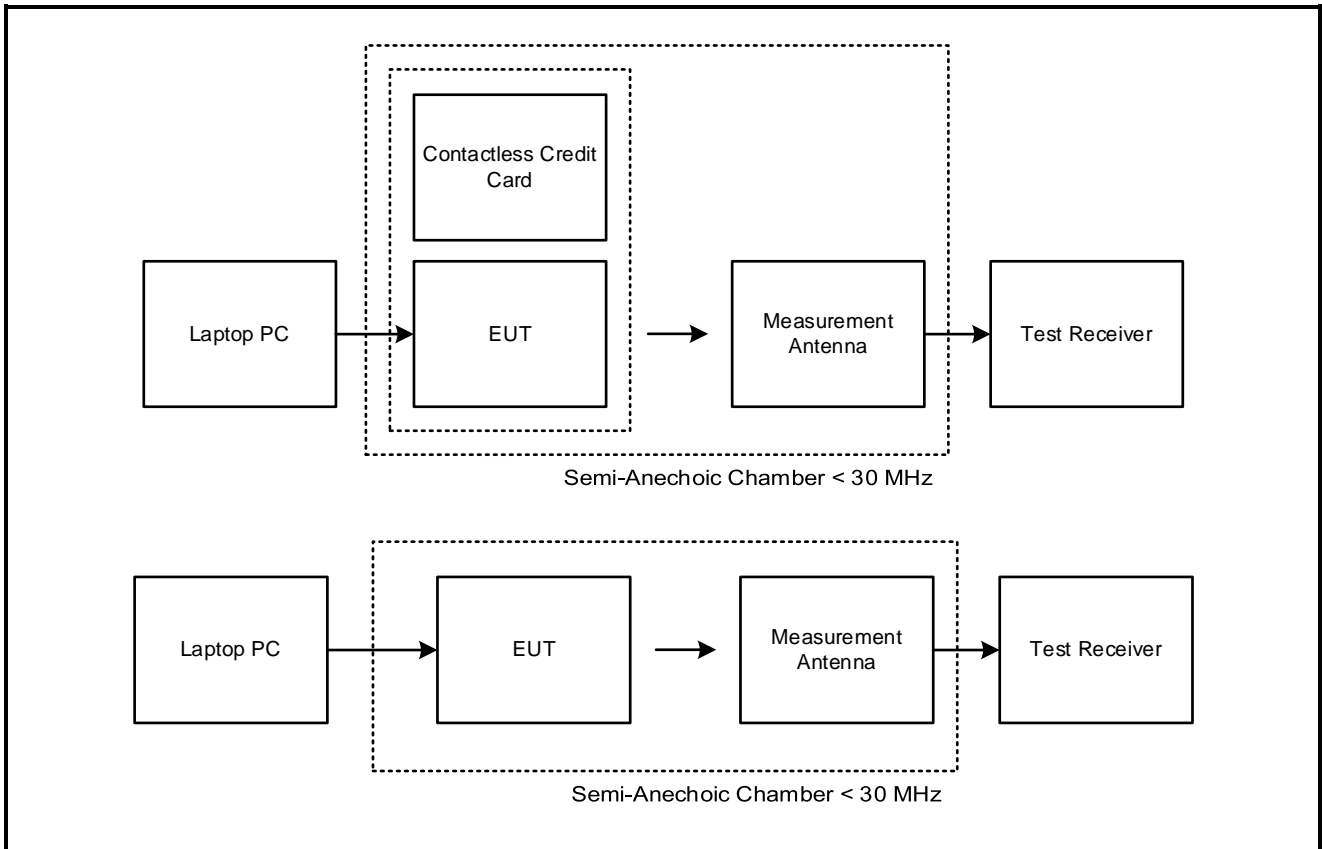

Transmitter Fundamental Field Strength (continued)

Results: Quasi Peak / Card Present

Frequency (MHz)	Antenna Polarity	Level (dBμV/m)	Limit at 30 m (dBμV/m)	Margin (dB)	Result
13.56	0° to EUT	45.5	84.0	38.5	Complied

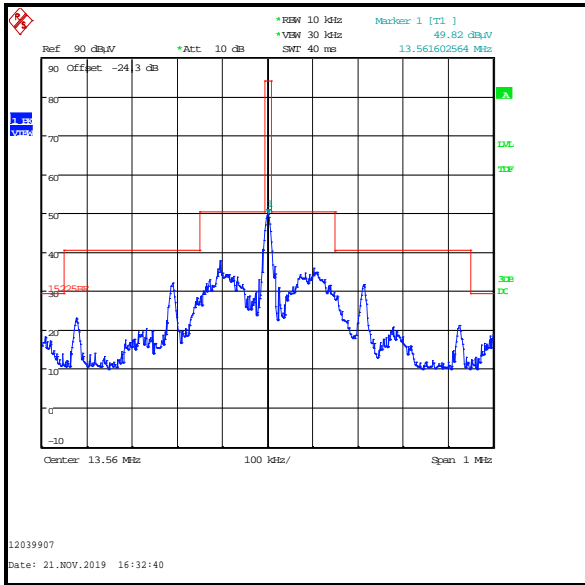

Fundamental field strength and spectrum mask / measured at 3 metres extrapolated to 30 metres / measured in a semi-anechoic chamber

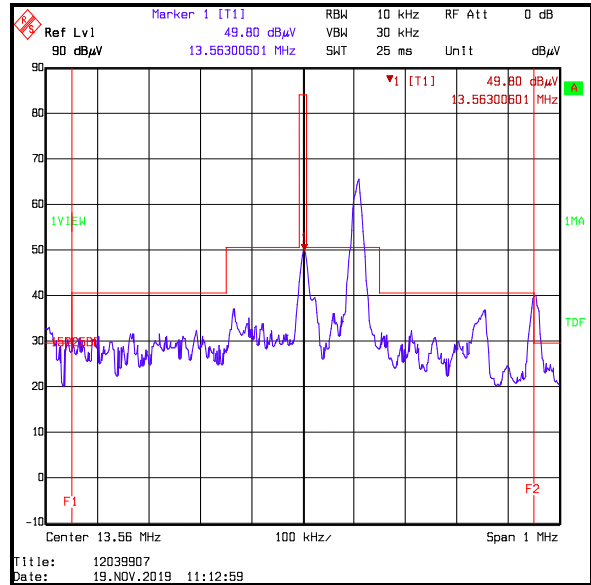

Fundamental field strength / EUT operating / 10 kHz measurement bandwidth measured at 30 metres / measured on an open field test site

Transmitter Fundamental Field Strength (continued)

Results: Quasi Peak / Without Card

Frequency (MHz)	Antenna Polarity	Level (dBµV/m)	Limit at 30 m (dBµV/m)	Margin (dB)	Result
13.56	0° to EUT	49.6	84.0	34.4	Complied

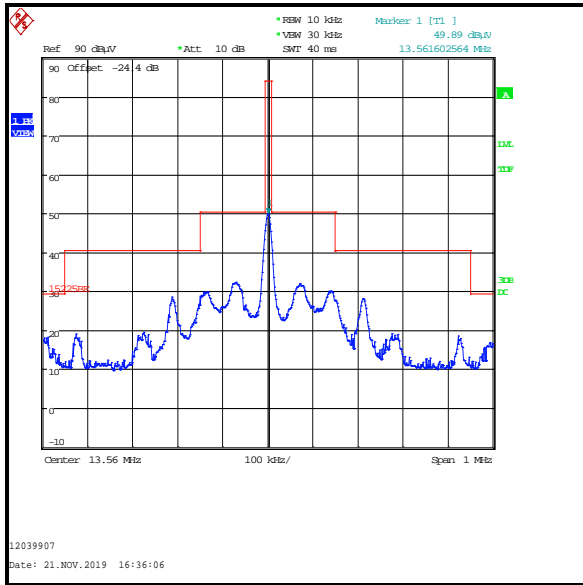

Fundamental field strength and spectrum mask / measured at 3 metres extrapolated to 30 metres / measured in a semi-anechoic chamber

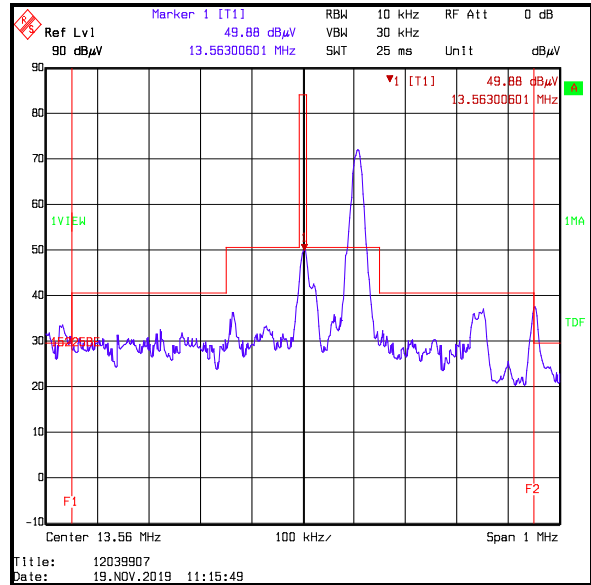

Fundamental field strength / EUT operating / 10 kHz measurement bandwidth measured at 30 metres / measured on an open field test site

Test Equipment Used:

Asset No.	Instrument	Manufacturer	Type No.	Serial No.	Date Calibration Due	Cal. Interval (Months)
M2043	Thermohygrometer	Testo	608-H1	45120017	06 Jan 2020	12
M127	Spectrum Analyser	Rohde & Schwarz	FSEB30	842659/016	18 Dec 2019	12
A3198	Magnetic Loop Antenna	ETS-Lindgren	6502	00221887	27 Mar 2020	12
M2054	Precision Steel Rule 1 m/39 in	RS	Not marked or stated	1218213/42	11 Sep 2023	60
A2686	Distance Measuring Wheel	Rolson Quality Tools	50799	Not stated	Calibrated before use	-
A2955	Protractor	Not stated	9781907550 980	#1	Calibration not required	-
M2040	Thermohygrometer	Testo	608-H1	45124934	06 Jan 2020	12
K0001	3 m RSE Chamber	Rainford EMC	N/A	N/A	16 Oct 2020	12
M2044	Test Receiver	Rohde & Schwarz	ESU26	100122	01 Apr 2020	12

5.2.3. Transmitter Radiated Spurious Emissions**Test Summary:**

Test Engineers:	Andrew Edwards & Nick Tye	Test Dates:	18 November 2019 to 21 November 2019
Test Sample Serial Number:	105118000026		

FCC Reference:	Parts 15.225(d) & 15.209(a)
Test Method Used:	ANSI C63.10 Sections 6.3, 6.4 and 6.5 and Notes below
Frequency Range:	9 kHz to 1000 MHz

Environmental Conditions:

Temperature (°C):	6 to 21
Relative Humidity (%):	36 to 74

Transmitter Radiated Spurious Emissions (continued)

Note(s):

1. In accordance with FCC KDB 414788, a *bona fide* attempt was made to perform measurements at the distances specified in Part 15.209(a) on an open field test site. It was not possible to determine the spurious emission values at the test distances specified below 30 MHz on an open field test site, therefore in accordance with 47 CFR 15.31(f), measurements were made at closer distances. Attempts were made to measure spurious emissions at 3, 30 and 300 metres on an open field test site on 19 & 20 November 2019. Spurious emissions from the EUT could not be seen above the ambient emissions present at the open field test site or the noise floor of the measurement system. Final measurement results from the semi-anechoic chamber tests on 21 November 2019 are shown in this section. In addition, the open field test result plots for measurements between 9 kHz and 30 MHz are also shown. These measurement plots are identical to background scan plots of the open field test site. Background scans of the open field test site and further information are shown in Appendix 1 of this test report.
2. The final measured value, for the given emission, in the table below incorporates the calibrated antenna factor and cable loss. The highest six spurious emissions in the range 30 MHz to 1 GHz were recorded in the table below.
3. The emission at 13.56 MHz on the 490 kHz to 30 MHz pre-scan plot is the EUT fundamental.
4. All other emissions were greater than 20 dB below the applicable limit, below the noise floor of the measurement system or ambient.
5. Measurement plots in this section for tests between 9 kHz and 30 MHz on an open field test site have markers placed on the highest level ambient emissions. This is for information only.
6. Measurements on 18 November 2019 were performed in a semi-anechoic chamber (UL VS LTD Asset Number K0001) at a distance of 3 metres. The EUT was placed at a height of 80 cm above the reference ground plane in the centre of the chamber turntable. Between 30 MHz and 1 GHz, maximum emission levels were determined by height searching the measurement antenna over the range 1 metre to 4 metres.
7. Limit lines shown on the semi-anechoic chamber plots from 9 kHz to 490 kHz have been extrapolated using a factor of 80 dB/decade to a test distance of 300 metres and 490 kHz to 30 MHz have been extrapolated using a factor of 40 dB/decade to a test distance of 30 metres.
8. There are ambient emissions seen between 2 to 30 MHz on the pre-scan plot for 490 kHz to 30 MHz performed in a semi-anechoic chamber. A background scan between 490 kHz to 30 MHz is stored on the company server and is available for inspection upon request.
9. A transducer factor was used on the spectrum analyser during open field tests. This factor includes correction between the fixed gain of the magnetic loop antenna and the calibration values. It also includes the value of the RF cable used to connect the antenna to the spectrum analyser which was incorporated into the annual calibration of the magnetic loop antenna.
10. Pre-scans were performed, and markers placed on the highest measured levels as follows:
 - a. For measurements below 150 kHz: The test receiver resolution bandwidth was set to 300 Hz and video bandwidth 1 kHz. A peak detector was used, sweep time was set to auto and trace mode was Max Hold. Markers were placed on the highest measured level.
 - b. For measurements between 150 to 490 kHz: The test receiver resolution bandwidth was set to 10 kHz and video bandwidth 30 kHz. An average detector was used, sweep time was set to auto and trace mode was Max Hold. Markers were placed on the highest measured level.
 - c. For measurements between 490 kHz to 30 MHz: The test receiver resolution bandwidth was set to 10 kHz and video bandwidth 30 kHz. A peak detector was used, sweep time was set to auto and trace mode was Max Hold. Markers were placed on the highest measured level.
 - d. For measurements between 30 MHz to 1 GHz: The test receiver resolution bandwidth was set to 120 kHz and video bandwidth 500 kHz. A peak detector was used, sweep time was set to auto and trace mode was Max Hold. Markers were placed on the highest measured level. All final measurements were performed using a CISPR quasi-peak detector.

Transmitter Radiated Spurious Emissions (continued)

Test setup for radiated measurements:

Measurements below 30 MHz on an Open Field Test Site

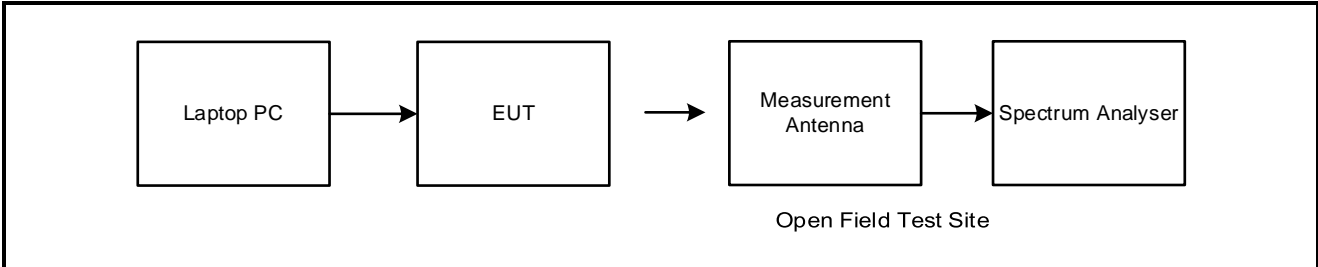

Measurements below 30 MHz in a semi-anechoic chamber

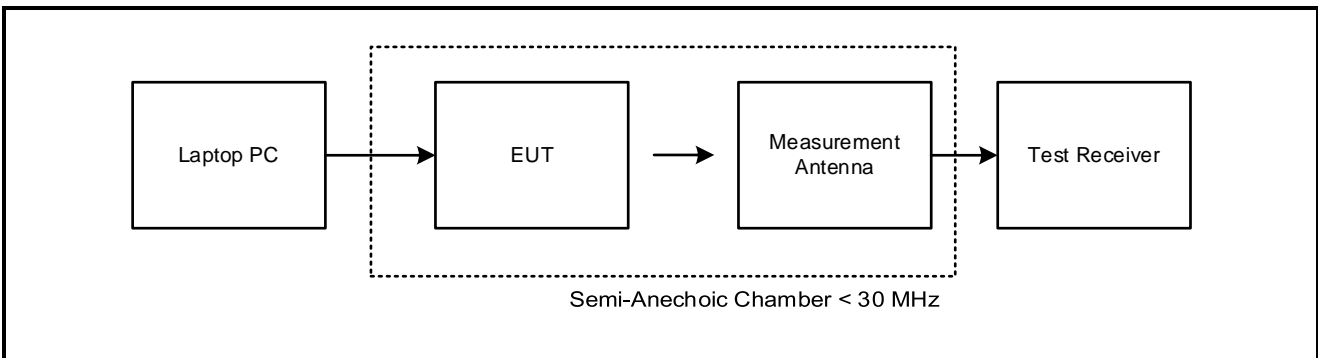

Measurements above 30 MHz in a semi-anechoic chamber

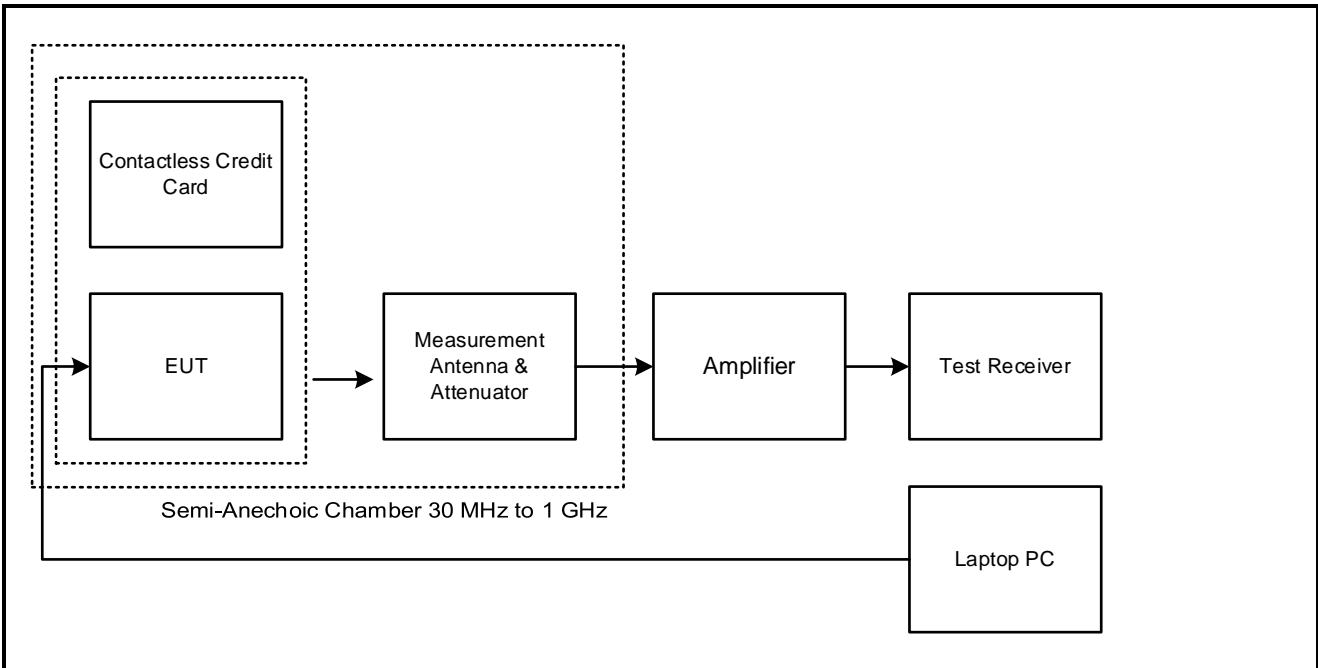

Transmitter Radiated Spurious Emissions (continued)**Results: Quasi Peak**

Frequency (MHz)	Antenna Polarity	Level (dBμV/m)	Limit (dBμV/m)	Margin (dB)	Result
131.264	Vertical	32.5	43.5	11.0	Complied
134.296	Vertical	34.9	43.5	8.6	Complied
137.254	Vertical	41.9	43.5	1.6	Complied
140.062	Vertical	36.9	43.5	6.6	Complied
149.163	Vertical	38.7	43.5	4.8	Complied
176.288	Vertical	32.5	43.5	11.0	Complied

Transmitter Radiated Spurious Emissions (continued)

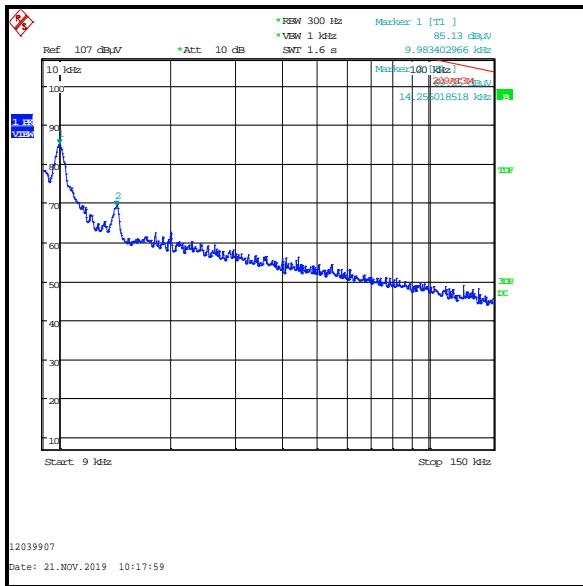

9 kHz to 150 kHz / peak detector / measured at 3 metres extrapolated to 300 metres / measured in a semi-anechoic chamber

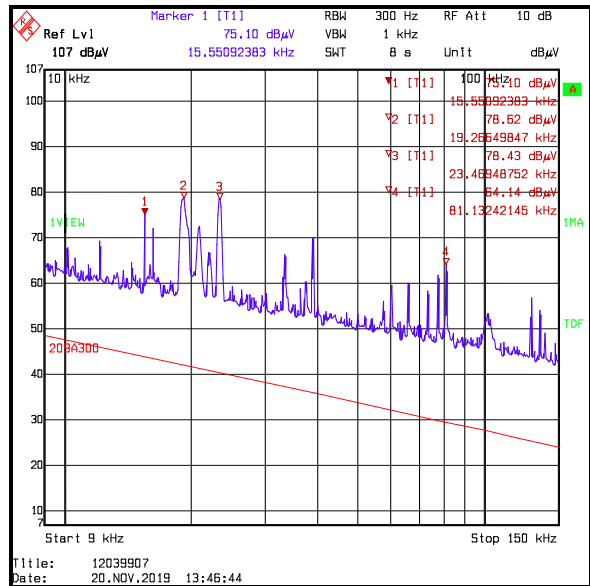

9 kHz to 150 kHz / peak detector / EUT operating / measured at 3 metres on an open field test site

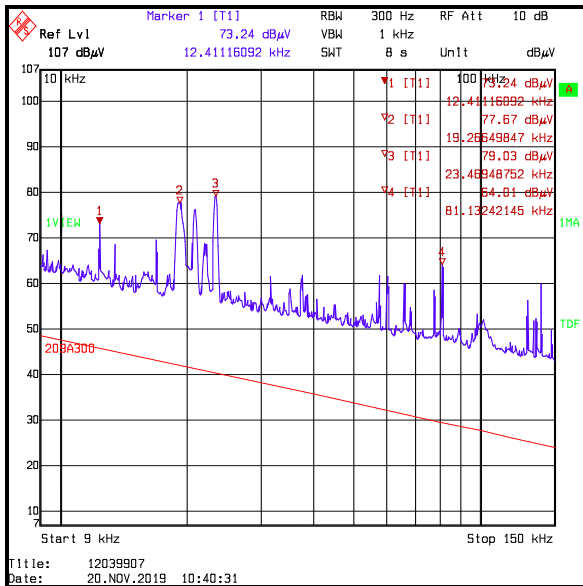

9 kHz to 150 kHz / peak detector / EUT operating / measured at 30 metres on an open field test site

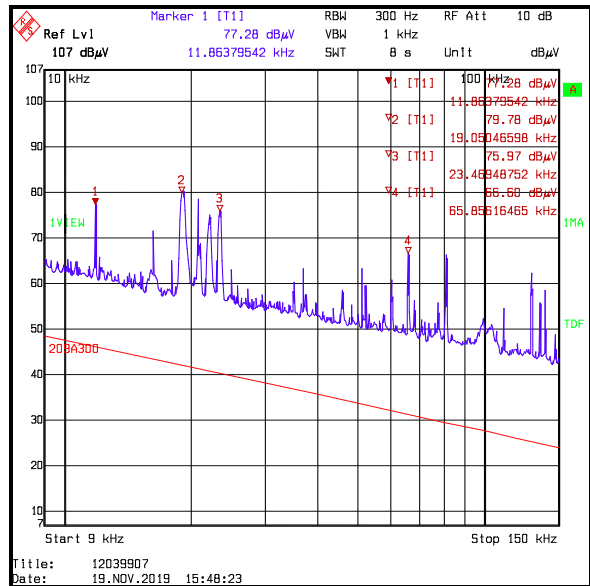

9 kHz to 150 kHz / peak detector / EUT operating / measured at 300 metres on an open field test site

Note: These plots are pre-scans and for indication purposes only. For final measurements, see accompanying table.

Transmitter Radiated Spurious Emissions (continued)

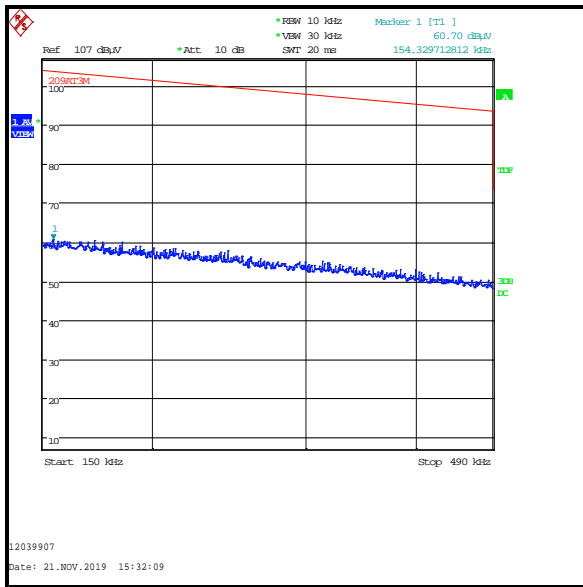

150 kHz to 490 kHz / average detector / measured at 3 metres extrapolated to 300 metres / measured in a semi-anechoic chamber

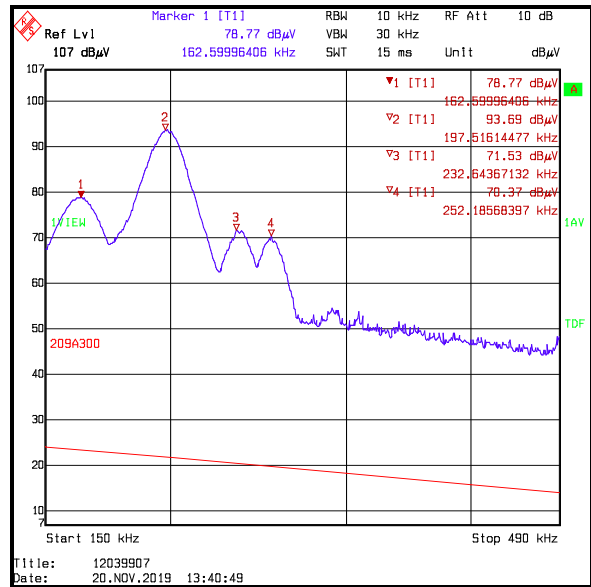

150 kHz to 490 kHz / average detector / EUT operating / measured at 3 metres on an open field test site

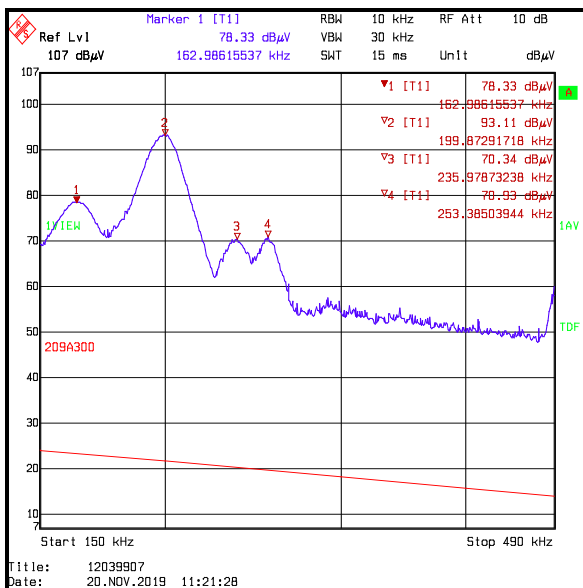

150 kHz to 490 kHz / average detector / EUT operating / measured at 30 metres on an open field test site

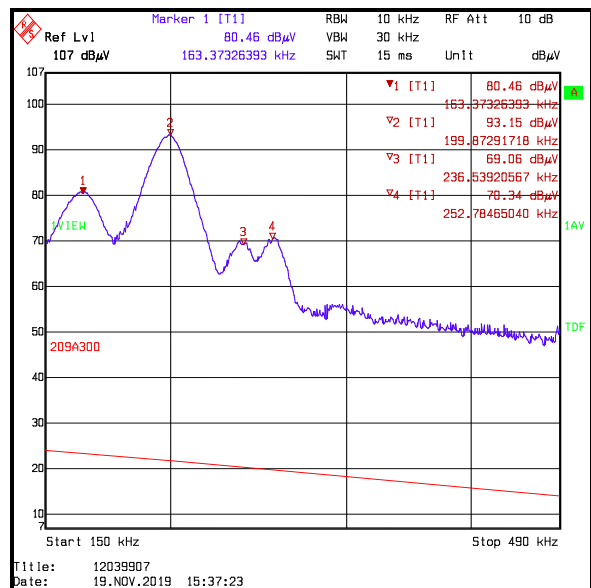

150 kHz to 490 kHz / average detector / EUT operating / measured at 300 metres on an open field test site

Note: These plots are pre-scans and for indication purposes only. For final measurements, see accompanying table.

Transmitter Radiated Spurious Emissions (continued)

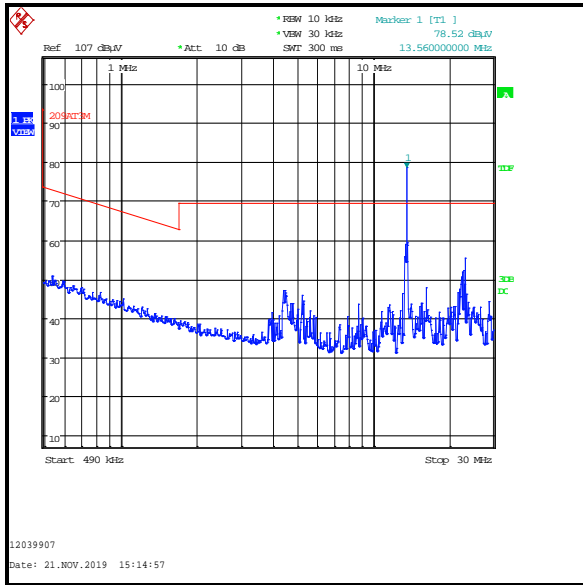

490 kHz to 30 MHz / peak detector / measured at 3 metres extrapolated to 30 metres / measured in a semi-anechoic chamber

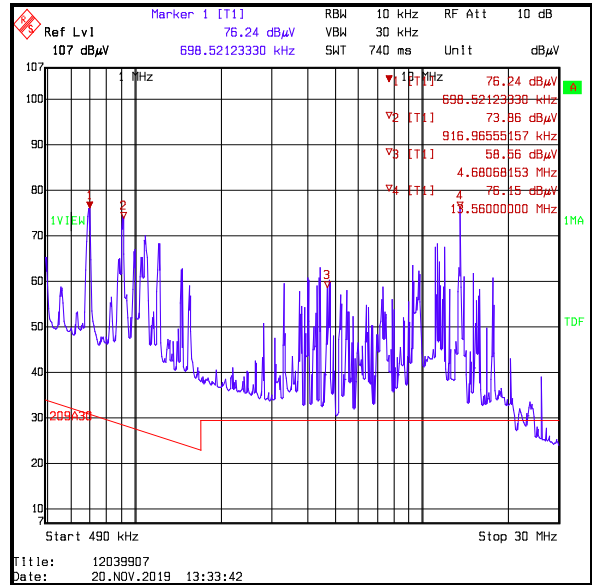

490 kHz to 30 MHz / peak detector / EUT operating / measured at 3 metres on an open field test site

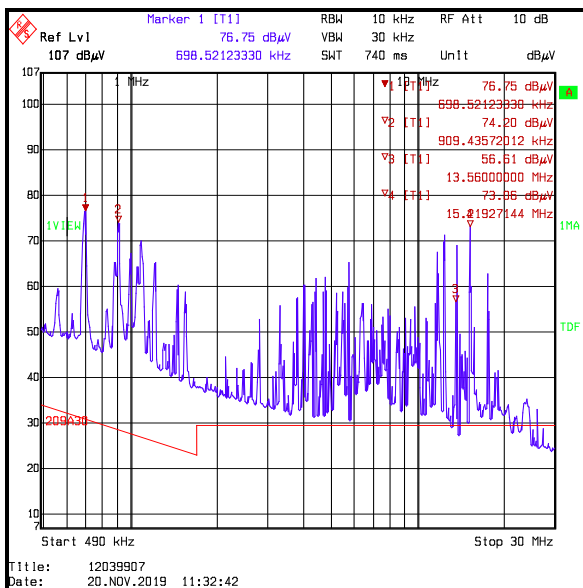

490 kHz to 30 MHz / peak detector / EUT operating / measured at 30 metres on an open field test site

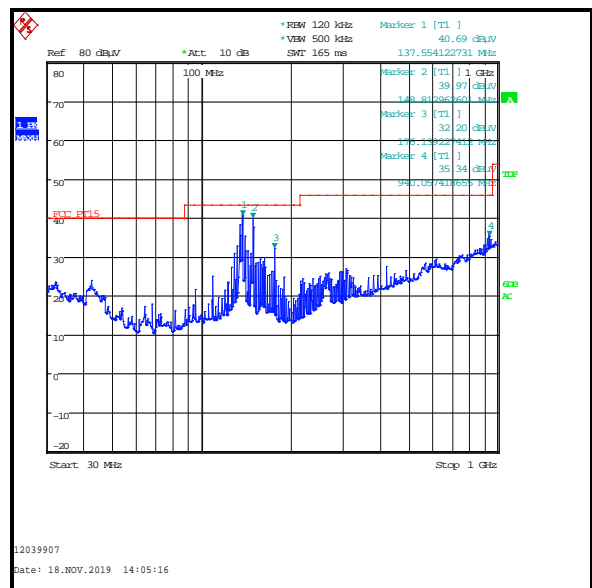

30 MHz to 1 GHz / peak detector (worst case) / measured at 3 metres in a semi-anechoic chamber

Note: These plots are pre-scans and for indication purposes only. For final measurements, see accompanying table.

Transmitter Radiated Spurious Emissions (continued)**Test Equipment Used:**

Asset No.	Instrument	Manufacturer	Type No.	Serial No.	Date Calibration Due	Cal. Interval (Months)
M2043	Thermohygrometer	Testo	608-H1	45120017	06 Jan 2020	12
M127	Spectrum Analyser	Rohde & Schwarz	FSEB30	842659/016	18 Dec 2019	12
A3198	Magnetic Loop Antenna	ETS-Lindgren	6502	00221887	27 Mar 2020	12
M2054	Precision Steel Rule 1 m/39 in	RS	Not marked or stated	1218213/42	11 Sep 2023	60
A2686	Distance Measuring Wheel	Rolson Quality Tools	50799	Not stated	Calibrated before use	-
A2955	Protractor	Not stated	9781907550 980	#1	Calibration not required	-
M2040	Thermohygrometer	Testo	608-H1	45124934	06 Jan 2020	12
K0001	3 m RSE Chamber	Rainford EMC	N/A	N/A	16 Oct 2020	12
M2044	Test Receiver	Rohde & Schwarz	ESU26	100122	01 Apr 2020	12
A3154	Pre-Amplifier	Com-Power	PAM-103	18020012	04 Oct 2020	12
A553	Antenna	Chase	CBL6111A	1593	14 Oct 2020	12
A3112	Attenuator	AtlanTecRF	AN18-06	219706#2	14 Oct 2020	12

5.2.4. Transmitter Band Edge Radiated Emissions

Test Summary:

Test Engineer:	Andrew Edwards	Test Date:	21 November 2019
Test Sample Serial Number:	105118000026		

FCC Reference:	Parts 15.225(c)(d) & 15.209(a)
Test Method Used:	ANSI C63.10 Section 6.10.4 and Notes below

Environmental Conditions:

Temperature (°C):	22
Relative Humidity (%):	36

Note(s):

1. For the field strength measurements in a semi-anechoic chamber, an offset was used to extrapolate the results at 3 metres to a distance of 30 metres and correlate measurements in a semi-anechoic chamber with measurements on an open field test site. For details on the calculations see Note 4 in Section 5.2.2 of this test report.
2. The spectrum analyser resolution bandwidth was set to 10 kHz and video bandwidth 30 kHz. A peak detector was used, sweep time was set to auto and the trace mode was Max Hold. The span was set to 1 MHz. Markers were placed at the lower and upper band edges. The results are given in the tables below.

Test setup:

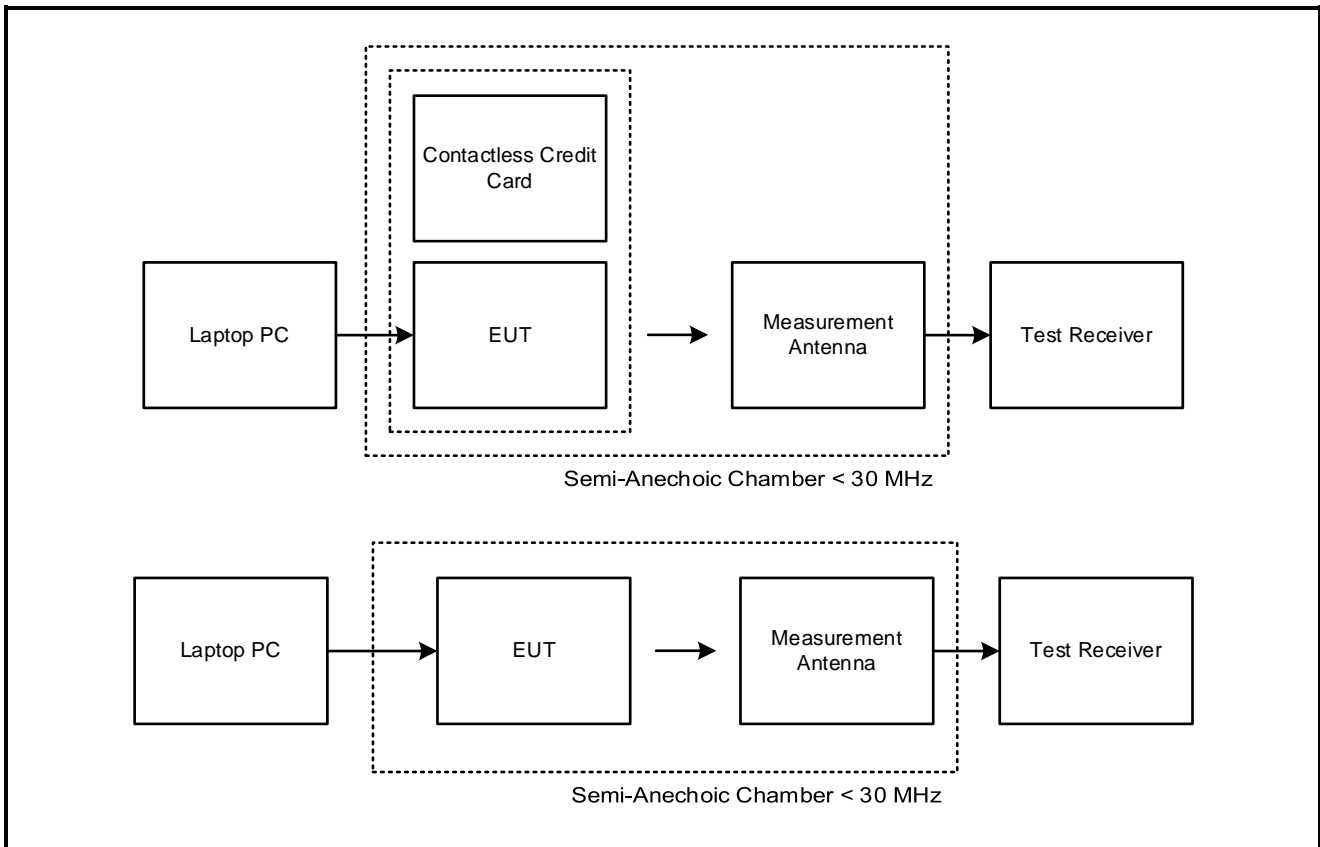

Transmitter Band Edge Radiated Emissions (continued)

Results: Peak / Lower Band Edge / Card Present

Frequency (MHz)	Level (dB μ V/m)	Limit (dB μ V/m)	Margin (dB)	Result
13.11	12.0	29.5	17.5	Complied

Results: Peak / Upper Band Edge / Card Present

Frequency (MHz)	Level (dB μ V/m)	Limit (dB μ V/m)	Margin (dB)	Result
14.01	10.7	29.5	18.8	Complied

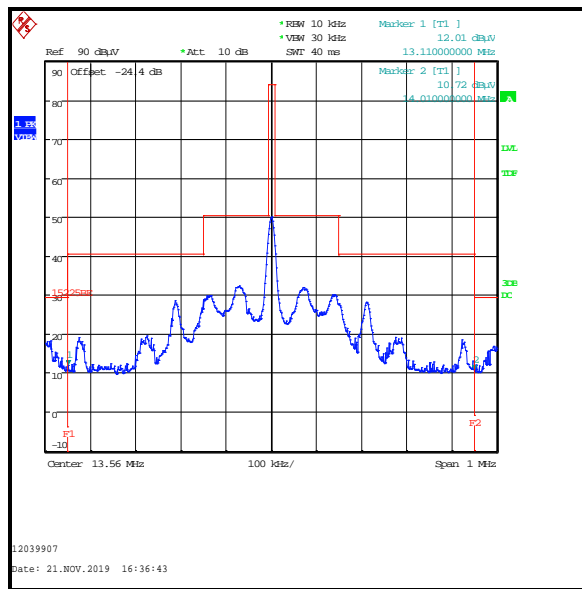

Transmitter Band Edge Radiated Emissions (continued)

Results: Peak / Lower Band Edge / Card Not Present

Frequency (MHz)	Level (dBμV/m)	Limit (dBμV/m)	Margin (dB)	Result
13.11	10.7	29.5	18.8	Complied

Results: Peak / Upper Band Edge / Card Not Present

Frequency (MHz)	Level (dBμV/m)	Limit (dBμV/m)	Margin (dB)	Result
14.01	10.5	29.5	19.0	Complied

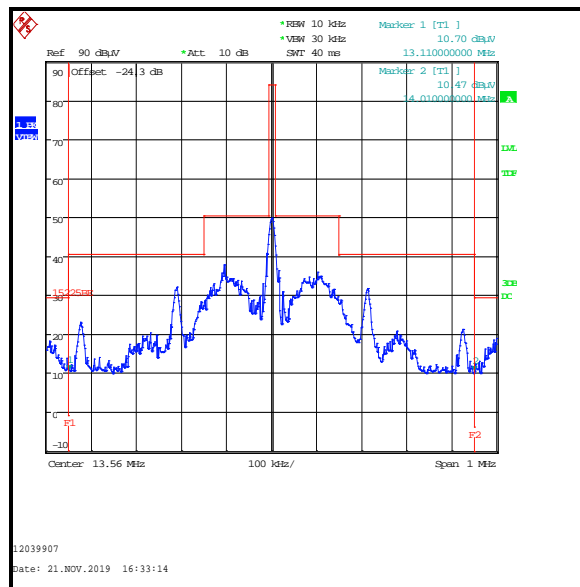

Test Equipment Used:

Asset No.	Instrument	Manufacturer	Type No.	Serial No.	Date Calibration Due	Cal. Interval (Months)
M2040	Thermohygrometer	Testo	608-H1	45124934	06 Jan 2020	12
K0001	3 m RSE Chamber	Rainford EMC	N/A	N/A	16 Oct 2020	12
M2044	Test Receiver	Rohde & Schwarz	ESU26	100122	01 Apr 2020	12
A3198	Magnetic Loop Antenna	ETS-Lindgren	6502	00221887	27 Mar 2020	12

5.2.5. Transmitter 20 dB Bandwidth

Test Summary:

Test Engineer:	Andrew Edwards	Test Date:	21 November 2019
Test Sample Serial Number:	105118000026		

FCC Reference:	Part 2.1049
Test Method Used:	ANSI C63.10 Section 6.9.2

Environmental Conditions:

Temperature (°C):	22
Relative Humidity (%):	36

Note(s):

- The test receiver resolution bandwidth was set to 10 kHz and video bandwidth 30 kHz. A peak detector was used, sweep time was set to auto and the trace mode was Max Hold. The span was set to 1 MHz. Normal and delta markers were placed 20 dB down from the peak of the carrier.

Test setup:

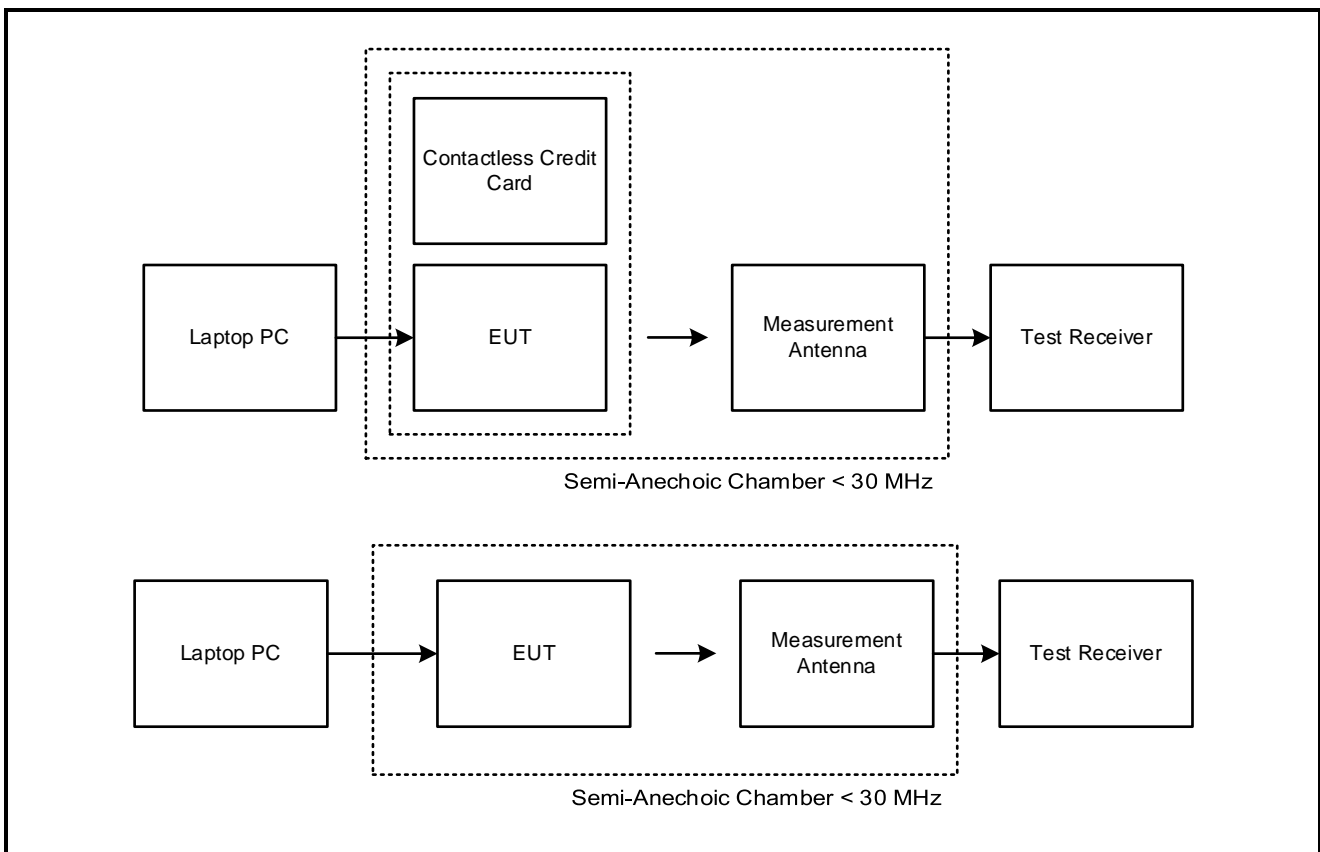

Transmitter 20 dB Bandwidth (continued)

Results:

Mode	20 dB Bandwidth (kHz)
Card Present	435.897
Card Not Present	282.051

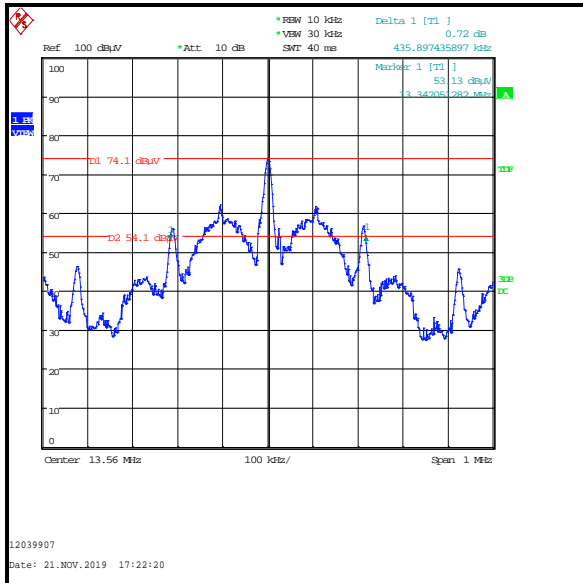

Card Present

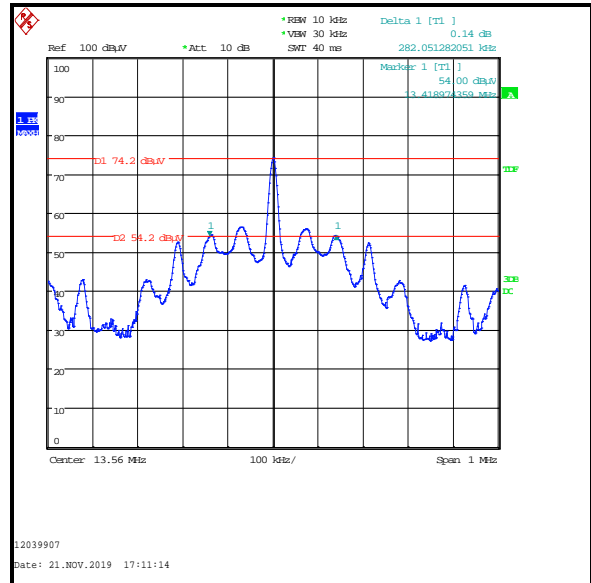

Without Card

Test Equipment Used:

Asset No.	Instrument	Manufacturer	Type No.	Serial No.	Date Calibration Due	Cal. Interval (Months)
M2040	Thermohygrometer	Testo	608-H1	45124934	06 Jan 2020	12
K0001	3 m RSE Chamber	Rainford EMC	N/A	N/A	16 Oct 2020	12
M2044	Test Receiver	Rohde & Schwarz	ESU26	100122	01 Apr 2020	12
A3198	Magnetic Loop Antenna	ETS-Lindgren	6502	00221887	27 Mar 2020	12

5.2.6. Transmitter Frequency Stability (Temperature & Voltage Variation)**Test Summary:**

Test Engineer:	Matthew Botfield	Test Date:	26 November 2019
Test Sample Serial Number:	105118000026		

FCC Reference:	Part 15.225(e)
Test Methods Used:	ANSI C63.10 Sections 6.8.1 and 6.8.2

Environmental Conditions:

Ambient Temperature (°C):	22
Ambient Relative Humidity (%):	56

Note(s):

1. Testing at voltage extremes was performed with the EUT powered by an external DC power supply. The EUT's battery was disconnected and the power supply was connected to the EUT's battery terminals. The customer declared the minimum and maximum primary supply voltages as 3.6V and 4.2V.
2. Frequency stability measurements were performed with a modulated carrier. The measurements were performed using the spectrum analyser marker counter function. The marker counter resolution was set to 1 Hz before any measurements were performed.
3. Temperature was monitored throughout the test with a calibrated digital thermometer.
4. Voltage was monitored throughout the test with a calibrated digital voltmeter.

Transmitter Frequency Stability (Temperature & Voltage Variation) (continued)

Test setup:

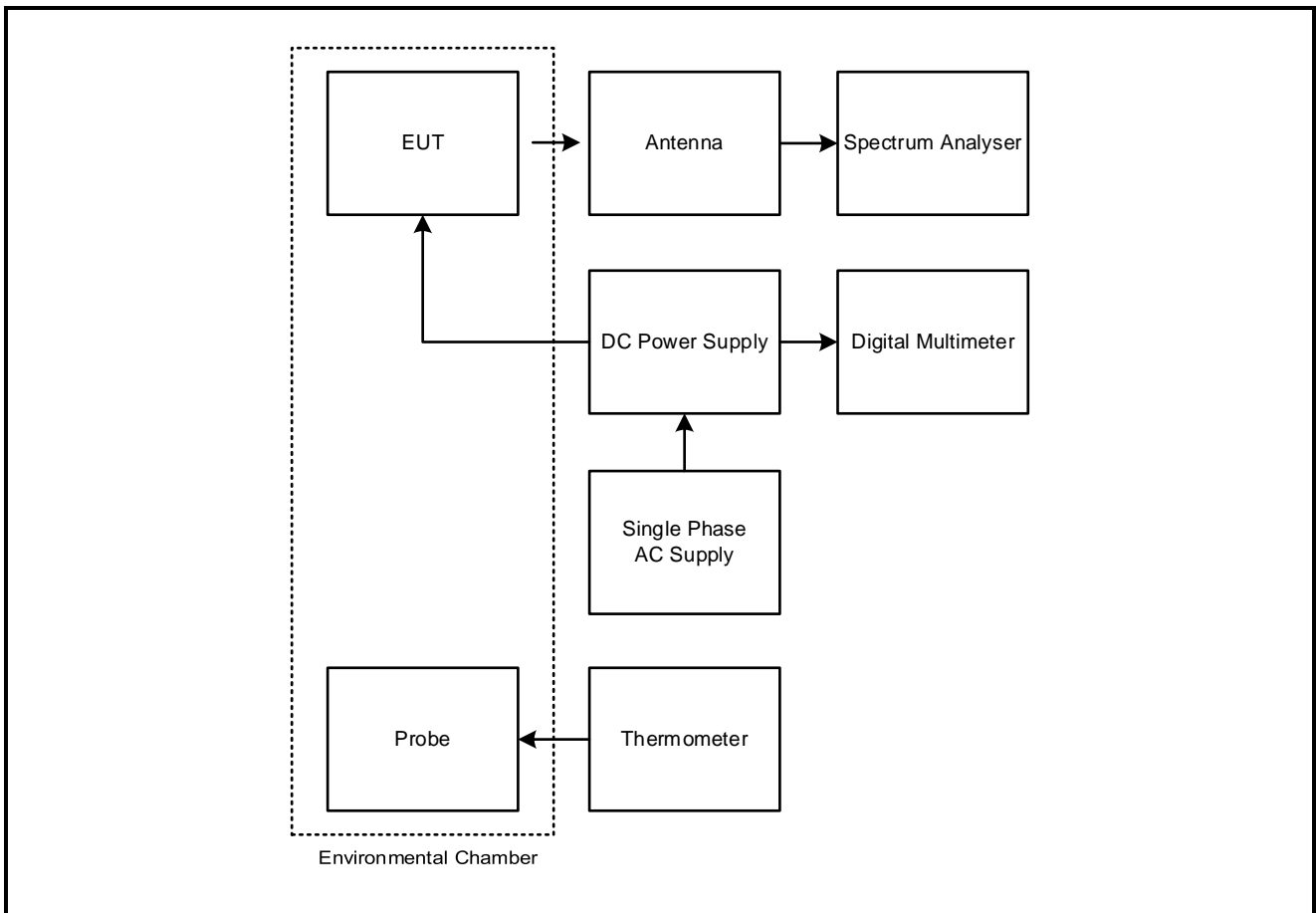

Transmitter Frequency Stability (Temperature & Voltage Variation) (continued)**Results: Maximum frequency error of the EUT with variations in ambient temperature**

Temperature (°C)	Time after Start-up			
	0 minutes	2 minutes	5 minutes	10 minutes
-20	13.560611 MHz	13.560631 MHz	13.560631 MHz	13.560651 MHz
20	13.560651 MHz	13.560651 MHz	13.560651 MHz	13.560651 MHz
50	13.560631 MHz	13.560611 MHz	13.560631 MHz	13.560631 MHz

Frequency with Worst Case Deviation (MHz)	Frequency Error (Hz)	Frequency Error (%)	Limit (%)	Margin (%)	Result
13.560651	651	0.004801	0.01	0.005199	Complied

Results: Maximum frequency error of the EUT with variations in nominal operating voltage at an ambient temperature of 20°C

Supply Voltage (V)	Nominal Frequency (MHz)	Measured Frequency (MHz)	Frequency Error (Hz)	Frequency Error (%)	Limit (%)	Margin (%)	Result
3.6	13.560000	13.560651	651	0.004801	0.01	0.005199	Complied
3.7	13.560000	13.560651	651	0.004801	0.01	0.005199	Complied
4.2	13.560000	13.560671	671	0.004948	0.01	0.005052	Complied

Test Equipment Used:

Asset No.	Instrument	Manufacturer	Type No.	Serial No.	Date Calibration Due	Cal. Interval (Months)
M2038	Thermohygrometer	Testo	608-H1	45124919	06 Jan 2020	12
M1124	Test Receiver	Rohde & Schwarz	ESIB26	100046	11 Oct 2020	12
A3198	Magnetic Loop Antenna	ETS-Lindgren	6502	00221887	27 Mar 2020	12
M1249	Thermometer	Fluke	52II	88800049	02 Jul 2020	12
M1251	Multimeter	Fluke	175	89170179	17 Apr 2020	12
S0564	DC Power Supply	TTI	PL330P	062941	Calibrated before use	-
E013	Environmental Chamber	Sanyo	MTH-4200PR	Non stated	Calibrated before use	-

6. Measurement Uncertainty

No measurement or test can ever be perfect and the imperfections give rise to error of measurement in the results. Consequently the result of a measurement is only an approximation to the value of the measurand (the specific quantity subject to measurement) and is only complete when accompanied by a statement of the uncertainty of the approximation.

The expression of uncertainty of a measurement result allows realistic comparison of results with reference values and limits given in specifications and standards.

The uncertainty of the result may need to be taken into account when interpreting the measurement results.

The reported expanded uncertainties below are based on a standard uncertainty multiplied by an appropriate coverage factor such that a confidence level of approximately 95% is maintained. For the purposes of this document "approximately" is interpreted as meaning "effectively" or "for most practical purposes".

Measurement Type	Range	Confidence Level (%)	Calculated Uncertainty
AC Conducted Spurious Emissions	0.15 MHz to 30 MHz	95%	±1.96 dB
20 dB Bandwidth	13 MHz to 14 MHz	95%	±4.59 %
Frequency Stability	13 MHz to 14 MHz	95%	±1.62 ppm
Radiated Spurious Emissions	9 kHz to 30 MHz	95%	±4.39 dB
Radiated Spurious Emissions	30 MHz to 1000 MHz	95%	±3.30 dB
Transmitter Fundamental Field Strength	13 MHz to 14 MHz	95%	±4.39 dB

The methods used to calculate the above uncertainties are in line with those recommended within the various measurement specifications. Where measurement specifications do not include guidelines for the evaluation of measurement uncertainty the published guidance of the appropriate accreditation body is followed.

7. Report Revision History

Version Number	Revision Details		
	Page No(s)	Clause	Details
1.0	-	-	Initial Version

8. Appendix 1

GPS coordinates of test location

Mag loop location (lower marker on photo)

N51° 08.739' W001° 26.328'

30 metre test point (middle marker on photo)

N51° 08.755' W001° 26.325'

300 metre test point (upper marker on photo)

N51° 08.895' W001° 26.289'



Details of 3 and 30 metre open field test site used on 19 to 20 November 2019

Temperature: 6°C to 8°C

Relative Humidity: 62% to 74%

Ground conditions: Wet on 19 November 2019 and dry on 20 November 2019

The test site was free from underground metal objects.

The EUT was powered at its nominal voltage from its internal battery. The USB cable was inserted and connected to the test laptop. The test laptop was powered by its own internal battery.

The EUT was placed on a plastic table at a height of 0.8 metres above ground level. All associated cables and support equipment were arranged according to ANSI C63.10-2013 Section 6.12.

The spectrum analyser used for measurements was located in a vehicle 30 metres from the magnetic loop antenna. Power to the test equipment was from a single phase supply. An RCD was fitted to the power source.

The test distance was from the centre of the mag loop antenna to the closest periphery of the EUT. This distance was maintained as the EUT was rotated.

Initially, The EUT was rotated through 360 degrees in 60 degree steps at both measurement distances. The mag loop antenna was positioned in accordance with ANSI C63.10-2013 section 6.4.6 at every position the EUT was moved to. The EUT and mag loop antenna were then rotated in small increments in order to maximise emission levels.

Details of 300 metre open field test site used on 19 November 2019

Temperature: 9°C

Relative Humidity: 74%

Ground conditions: Wet

The test site was free from underground metal objects.

The EUT was powered at its nominal voltage from its internal battery. The USB cable was inserted and connected to the test laptop. The test laptop was powered by its own internal battery.

The EUT was placed on a plastic table at a height of 0.8 metres above ground level. All associated cables were arranged according to ANSI C63.10-2013 Section 6.12.

The spectrum analyser used for measurements was located in a vehicle 30 metres from the magnetic loop antenna. Power to the test equipment was from a single phase supply. An RCD was fitted to the power source.

The test distance was from the centre of the mag loop antenna to the closest periphery of the EUT. This distance was maintained as the EUT was rotated.

Initially, The EUT was rotated through 360 degrees in 45 degree steps at 300m measurement distance. The mag loop antenna was positioned in accordance with ANSI C63.10-2013 section 6.4.6 at every position the EUT was moved to. The EUT and mag loop antenna were then rotated in small increments in order to maximise emission levels.

Comparison of open field test site with semi-anechoic chamber measurements at 3 metres

Radiated measurements were performed an open field test site and within a 5 metre semi-anechoic chamber.

For the signal source, a modified loop antenna was connected to a signal generator at the transmit side. A standard active magnetic loop antenna was connected to a spectrum analyser at the receive side. The signal generator was set to its maximum supported output power and the signal was transmitted to the spectrum analyser via the two antennas and associated RF cables.

A sweep in small frequency increments was performed from 9 kHz to 30 MHz. The sweep was repeatedly performed with both antennas rotated about the axis in various orientations. Received levels for all orientations were recorded and the maximum levels for the open field test site and the semi-anechoic chamber are shown on the graph below. Full data for both tests are archived on the UL VS LTD IT server and available for inspection on request.

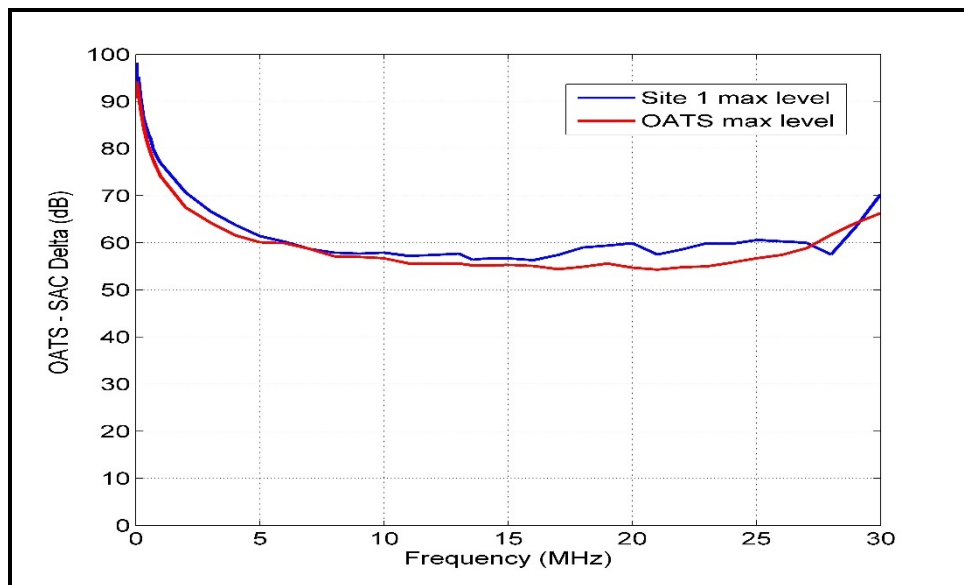

The conclusion was that the open field test site compares well with the semi-anechoic chamber at a measurement distance of 3 metres. If anything, the semi-anechoic chamber results are generally slightly higher. This means that if the measurement passes in the semi-anechoic chamber, it will pass with a higher margin on an open field test site.

The magnetic loop antenna used to perform these measurements is the same antenna or same type of antenna used during measurements contained in this test report.

Verification of open field test site and semi-anechoic chamber measurements at 3 metres prior to performing measurements

Two reference units are used for verification of the measurement system before testing commences. Both reference units are door entry systems modified by the customer for test purposes only.

One reference unit transmits a continuous, modulated signal at a fixed frequency of 125 kHz when a 12 Volt battery is connected. The output power is fixed and known to be stable.

The second transmits a continuous, modulated signal at a fixed frequency of 13.56 MHz when a 12 Volt battery is connected. The output power is fixed and known to be stable.

Both frequencies are commonly used RFID frequencies.

A UL VS LTD internal verification document explains the procedure in detail. A brief description is given below.

The centre of the magnetic loop antenna is placed exactly 3 metres from the reference unit. The reference unit is placed on a plastic table at a height of 0.8 metres above floor level and the centre of the mag loop antenna is 1 metre above the floor level. The mag loop antenna and reference unit are oriented in certain positions to ensure repeatability.

Each reference unit is connected to a 12 Volt battery and once transmitting, the maximum raw received level at each of the two frequencies is read on the spectrum analyser by using the marker peak function. The measured level has to be within certain levels as specified in the UL VS LTD internal test procedure. The plot of the verification measurement is archived on the UL VS LTD IT server. The peak level of each reference unit is recorded on a spreadsheet which is also archived on the UL VS LTD IT server.

The internal verification procedure and verification plots are available for inspection on request.

Radiated measurements below 30 MHz were performed in a semi-anechoic chamber at a distance of 3 metres.

Verification plots of the two reference units at a measurement distance of 3 metres are shown on the following page. Plots were taken on an open field test site (19 November 2019) and in a semi-anechoic chamber (21 November 2019).

Verification of open field test site and semi-anechoic chamber measurements at 3 metres prior to performing measurements (continued)

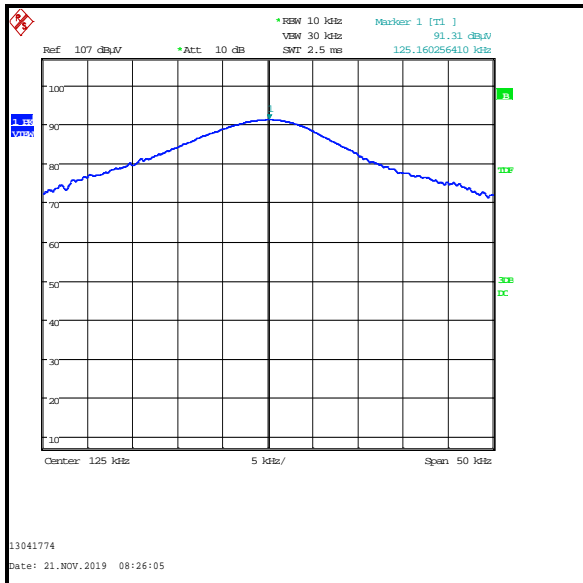

125 kHz reference unit signal at 3 metres in a semi-anechoic chamber on 21 November 2019

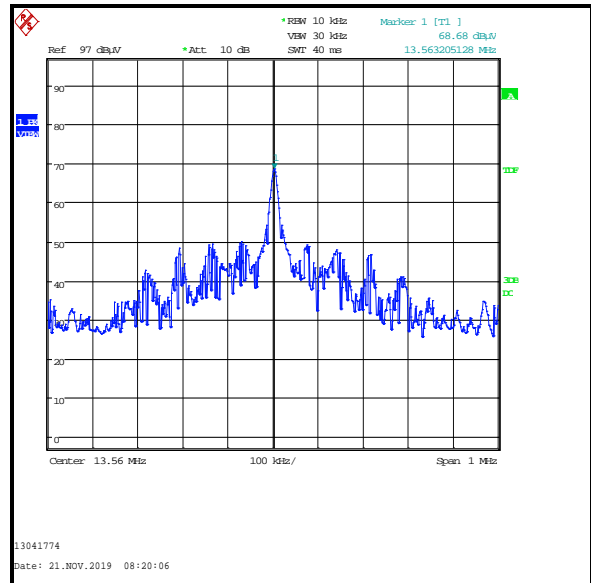

13.56 MHz reference unit signal at 3 metres in a semi-anechoic chamber on 21 November 2019

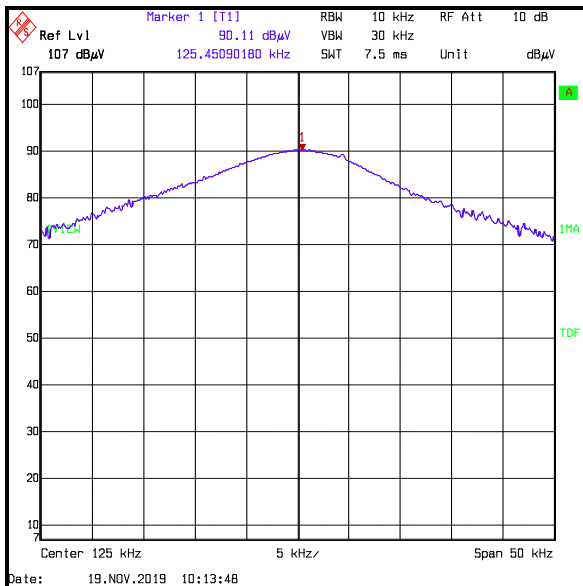

125 kHz reference unit signal at 3 metres on an open field test site on 19 November 2019

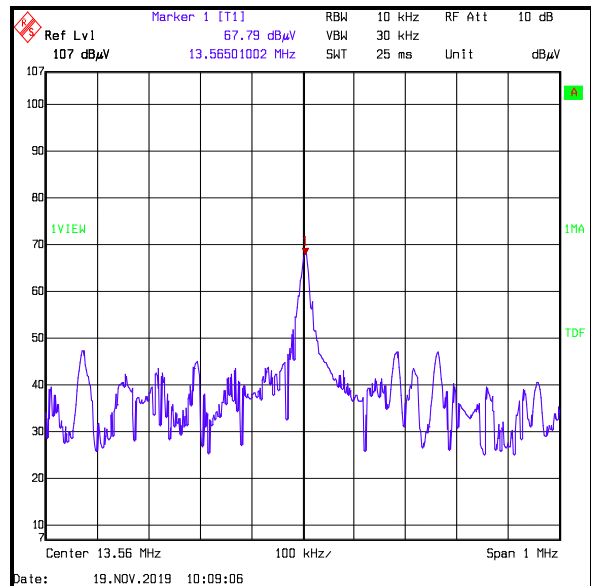

13.56 MHz reference unit signal at 3 metres on an open field test site on 19 November 2019

Note(s):

1. The above plots show comparable measurements of reference units on an open field test site and in a semi-anechoic chamber at spot frequencies.

Background scans of the open field test site

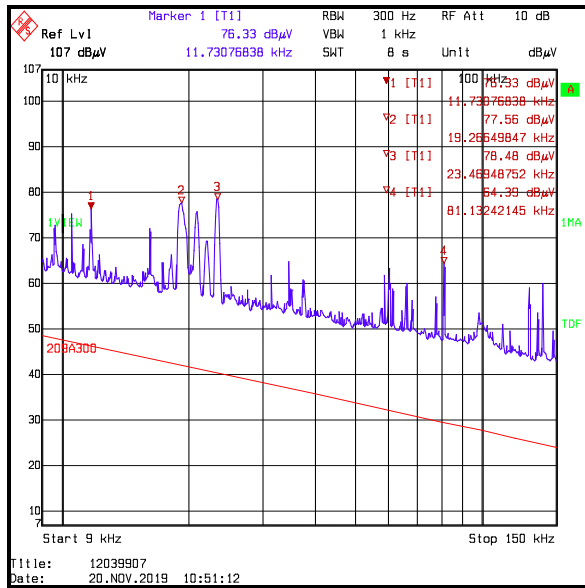

**Frequency range: 9 kHz to 150 kHz
Peak detector / background scan**

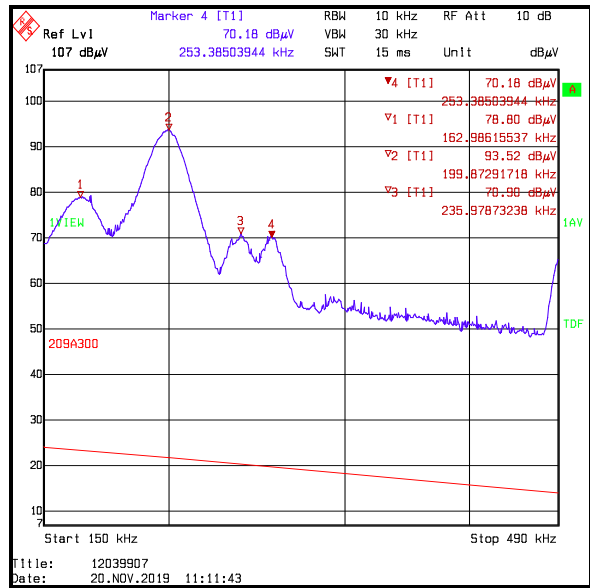

**Frequency range: 150 kHz to 490 kHz
Average detector / background scan**

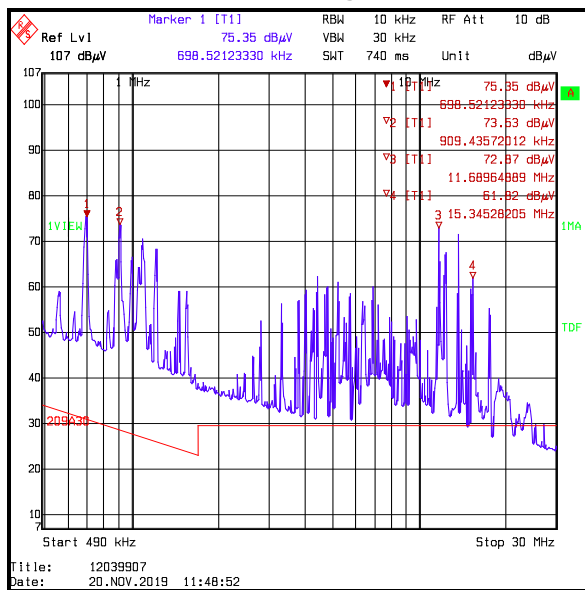

**Frequency range: 490 kHz to 30 MHz
Peak detector / background scan**

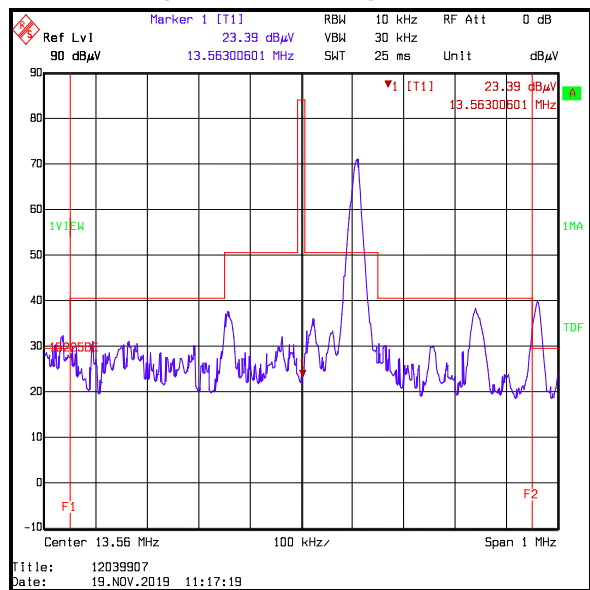

**Frequency range: 13.06 MHz to 14.06 MHz /
background scan of the open field test site**

Note(s):

1. The above plots are background scans of the open field test site. The EUT was switched off when the background scans were performed.
2. As the open field test site measurements were performed over more than one day, only the background scans from one day are shown above. Plots of scans taken on other dates are stored on the company IT network. These are available for inspection upon request.

--- END OF REPORT ---