



TEST REPORT

Report Number. : 12422353-E1V3

Applicant : DATECS Ltd.
DEPARTMENT OF INNOVATIVE TECHNOLOGIES
4 "Datecs" Str.
1592 SOFIA, BULGARIA

Model : INFINEA TAB M LITE

FCC ID : YRWITML

EUT Description : Payment terminal with magnetic card reader and contactless card reader

Test Standard(s) : FCC 47 CFR PART 15 SUBPART C

Date Of Issue:

October 07, 2019

Prepared by:

UL Verification Services Inc.
47173 Benicia Street
Fremont, CA 94538, U.S.A.
TEL: (510) 771-1000
FAX: (510) 661-0888



Revision History

<u>Rev.</u>	<u>Issue Date</u>	<u>Revisions</u>	<u>Revised By</u>
V1	09/17/18	Initial Issue	
V2	07/23/19	Report revised based on reviewer's comments.	Bobby Bayani
V3	10/7/19	Report revised based on reviewer's comments.	Bobby Bayani

TABLE OF CONTENTS

1. ATTESTATION OF TEST RESULTS	4
2. TEST METHODOLOGY	6
3. FACILITIES AND ACCREDITATION	6
4. CALIBRATION AND UNCERTAINTY	6
4.1. MEASURING INSTRUMENT CALIBRATION	6
4.2. SAMPLE CALCULATION	6
4.3. MEASUREMENT UNCERTAINTY.....	7
5. EQUIPMENT UNDER TEST	8
5.1. DESCRIPTION OF EUT	8
5.2. MAXIMUM OUTPUT POWER.....	8
5.3. DESCRIPTION OF AVAILABLE ANTENNAS	8
5.4. SOFTWARE AND FIRMWARE.....	8
5.5. WORST-CASE CONFIGURATION AND MODE.....	8
5.6. DESCRIPTION OF TEST SETUP.....	9
6. TEST AND MEASUREMENT EQUIPMENT	12
7. OCCUPIED BANDWIDTH	13
7.1. 20 dB BANDWIDTH.....	13
8. RADIATED EMISSION TEST RESULTS.....	15
8.1. LIMITS AND PROCEDURE	15
8.2. FUNDAMENTAL AND SPURIOUS EMISSIONS (0.09 - 30 MHz)	17
8.2.1. FUNDAMENTAL – Without iPhone	17
8.2.1. FUNDAMENTAL – With iPhone	18
8.2.1. SPURIOUS EMISSION (0.09 - 30 MHz) – Without iPhone	19
8.2.1. SPURIOUS EMISSION (0.09 - 30 MHz) – With iPhone	20
8.3. TX SPURIOUS EMISSION 30 TO 1000 MHz	21
8.3.1. Without iPhone	21
8.3.1. With iPhone	23
9. FREQUENCY STABILITY	25
10. AC MAINS LINE CONDUCTED EMISSIONS	26
10.1. NORMAL OPERATION WITH ANTENNA	27
10.1.1. NORMAL OPERATION WITH ANTENNA PORT TERMINATED	29
11. SETUP PHOTOS	31

1. ATTESTATION OF TEST RESULTS

COMPANY NAME: DATECS Ltd.

EUT DESCRIPTION: Payment terminal with magnetic card reader and contactless card reader.
This device is designed to operate with an iPhone 8 Plus.

MODEL: INFINEA TAB M LITE

SERIAL NUMBER: 2619000055, 2619000062

DATE TESTED: September 7 – September 11, 2018; October 3, 2019

APPLICABLE STANDARDS	
STANDARD	TEST RESULTS
FCC PART 15 SUBPART C	Complies

UL Verification Services Inc. tested the above equipment in accordance with the requirements set forth in the above standards. All indications of Pass/Fail in this report are opinions expressed by UL Verification Services Inc. based on interpretations and/or observations of test results. Measurement Uncertainties were not taken into account and are published for informational purposes only. The test results show that the equipment tested is capable of demonstrating compliance with the requirements as documented in this report.

Note: The results documented in this report apply only to the tested sample, under the conditions and modes of operation as described herein. This document may not be altered or revised in any way unless done so by UL Verification Services Inc. and all revisions are duly noted in the revisions section. Any alteration of this document not carried out by UL Verification Services Inc. will constitute fraud and shall nullify the document. This report must not be used by the client to claim product certification, approval, or endorsement by NVLAP, NIST, any agency of the Federal Government, or any agency of any government.

Reviewed By:



Bobby Bayani
Lead Project Engineer
UL Verification Service Inc.

Prepared By:

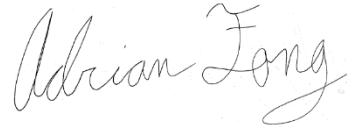

Adrian Fong
Laboratory Engineer
UL Verification Services Inc.

Approved & Released For
UL Verification Services Inc By:



Dan Corona
Operations Leader
UL Verification Service Inc.

2. TEST METHODOLOGY

The tests documented in this report were performed in accordance with ANSI C63.10-2013, FCC CFR 47 Part 2, FCC CFR 47 Part 15.

3. FACILITIES AND ACCREDITATION

The test sites and measurement facilities used to collect data are located at 47173 and 47266 Benicia Street, and at 47658 Kato Road, Fremont, California, USA. Line conducted emissions are measured only at the 47173 address. The following table identifies which facilities were utilized for radiated emission measurements documented in this report. Specific facilities are also identified in the test results sections.

47173 Benicia Street	47266 Benicia Street	47658 Kato Rd.
<input checked="" type="checkbox"/> Chamber A	<input type="checkbox"/> Chamber D	<input checked="" type="checkbox"/> Chamber I
<input type="checkbox"/> Chamber B	<input type="checkbox"/> Chamber E	<input type="checkbox"/> Chamber J
<input type="checkbox"/> Chamber C	<input type="checkbox"/> Chamber F	<input checked="" type="checkbox"/> Chamber K
	<input type="checkbox"/> Chamber G	<input type="checkbox"/> Chamber L
	<input type="checkbox"/> Chamber H	

The above test sites and facilities are covered under FCC Test Firm Registration # 208313. Chambers above are covered under Industry Canada company address and respective code.

UL Verification Services Inc. is accredited by NVLAP, Laboratory Code 200065-0

4. CALIBRATION AND UNCERTAINTY

4.1. MEASURING INSTRUMENT CALIBRATION

The measuring equipment utilized to perform the tests documented in this report has been calibrated in accordance with the manufacturer's recommendations, and is traceable to recognized national standards.

4.2. SAMPLE CALCULATION

Where relevant, the following sample calculation is provided:

$$\begin{aligned} \text{Field Strength (dBuV/m)} &= \text{Measured Voltage (dBuV)} + \text{Antenna Factor (dB/m)} + \\ &\text{Cable Loss (dB)} - \text{Preamp Gain (dB)} \\ 36.5 \text{ dBuV} + 18.7 \text{ dB/m} + 0.6 \text{ dB} - 26.9 \text{ dB} &= 28.9 \text{ dBuV/m} \end{aligned}$$

4.3. MEASUREMENT UNCERTAINTY

Where relevant, the following measurement uncertainty levels have been estimated for tests performed on the apparatus:

PARAMETER	UNCERTAINTY
Worst Case Conducted Disturbance, 9KHz to 0.15 MHz	3.84 dB
Worst Case Conducted Disturbance, 0.15 to 30 MHz	3.65 dB
Worst Case Radiated Disturbance, 9KHz to 30 MHz	3.15 dB
Worst Case Radiated Disturbance, 30 to 1000 MHz	5.36 dB
Worst Case Radiated Disturbance, 1000 to 18000 MHz	4.32 dB
Worst Case Radiated Disturbance, 18000 to 26000 MHz	4.45 dB
Worst Case Radiated Disturbance, 26000 to 40000 MHz	5.24 dB

Uncertainty figures are valid to a confidence level of 95%.

5. EQUIPMENT UNDER TEST

5.1. DESCRIPTION OF EUT

Payment terminal with magnetic card reader and contactless card reader.

5.2. MAXIMUM OUTPUT POWER

The testing was performed at 3 meter. The transmitter maximum E-field at 30 meter distance is 35.34 dBuV/m which is converted from the 3 meter data.

5.3. DESCRIPTION OF AVAILABLE ANTENNAS

The radio utilizes a flexible printed circuit board antenna.

5.4. SOFTWARE AND FIRMWARE

The test utility software used during testing was IRETest2.0.3.

5.5. WORST-CASE CONFIGURATION AND MODE

Radiated emission was performed with the EUT set to transmit at the channel with highest output power as worst-case scenario.

The fundamental of the EUT was investigated under three orthogonal orientations X (Flatbed), Y (Landscape), and Z (Portrait). The Y (Landscape) orientation was determined to be the worst-case orientation.

Although these tests were performed other than open area test site, adequate comparison measurements were confirmed against 30 m open are test site. Therefore sufficient tests were made to demonstrate that the alternative site produces results that correlate with the ones of tests made in an open field based on KDB 414788.

5.6. DESCRIPTION OF TEST SETUP

SUPPORT EQUIPMENT

Description	Manufacturer	Model	Serial Number	FCC ID
AC Adapter	Apple	A1265	1X116KK248QZ	N/A
iPhone 8	Apple	A1778	C7CS5050HL4Q	BCG-E3091A

I/O CABLES

I/O Cable List						
Cable No	Port	# of identical ports	Connector Type	Cable Type	Cable Length (m)	Remarks
1	USB	1	USB	Unshielded	1	EUT to AC/DC Charger

TEST SETUP

The EUT is stand alone. Test software exercised the radio card.

SETUP DIAGRAM

Without iPhone

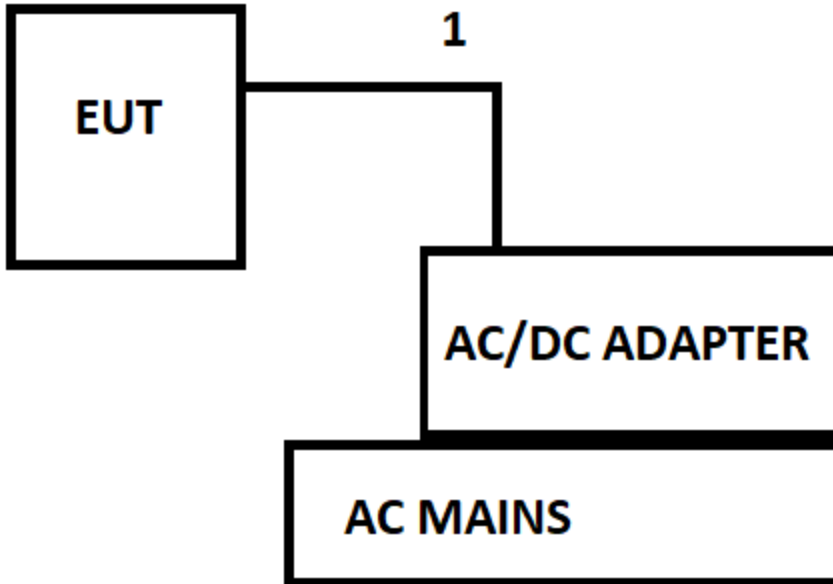

With iPhone

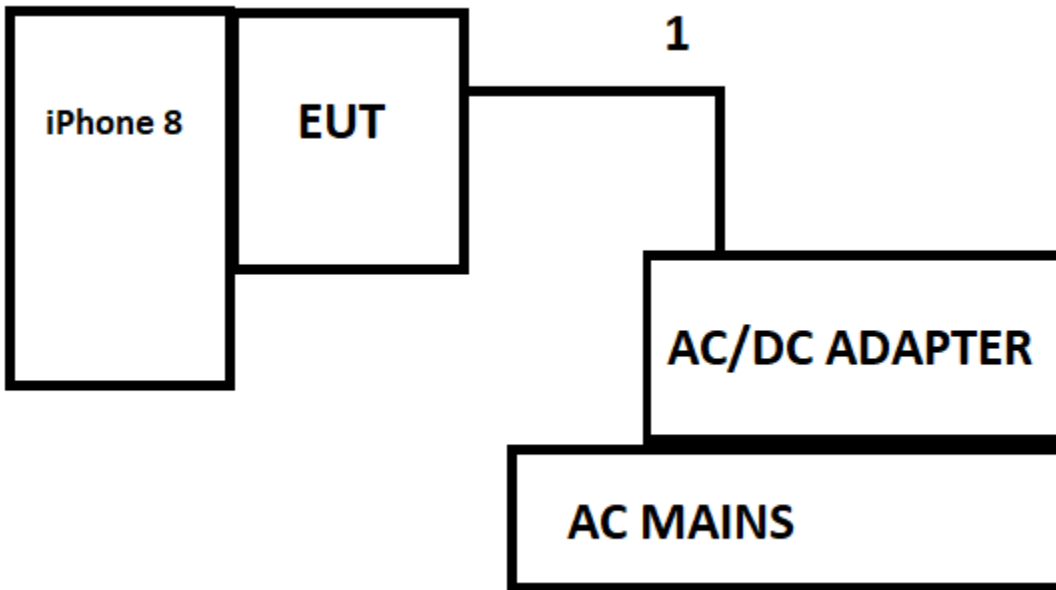

6. TEST AND MEASUREMENT EQUIPMENT

The following test and measurement equipment was utilized for the tests documented in this report:

Test Dates: 9/7/18 – 9/11/18

TEST EQUIPMENT LIST					
Description	Manufacturer	Model	ID Num	Cal Due	Last Cal
Amplifier, 100KHz to 1GHz, 32dB	Agilent (Keysight) Technologies	8447D	T15	10/16/2018	10/16/2017
Antenna, Broadband Hybrid, 30MHz to 2000MHz	Sunol Sciences Corp.	JB1	T130	10/16/2018	10/16/2017
Semianechoic Chamber A	TDK RF SOLUTIONS INC.	N/A	T1199	6/12/2019	6/12/2018
Spectrum Analyzer	Agilent (Keysight) Technologies	N9030A	T818	06/12/2019	06/12/2018
Spectrum Analyzer, PXA, 3Hz to 44GHz	Agilent (Keysight) Technologies	N9030A	T1466	04/16/2019	04/16/2018
Thermometer - Digital	Control Company	14-650-118	PRE0177861	02/26/2019	02/26/2018
Antenna, Active Loop 9 kHz - 30 MHz	Com-Power Corp.	AL-130R	T1868	12/13/2018	12/13/2017

UL SOFTWARE			
Radiated Software	UL	UL EMC	Ver 9.5, Dec 01, 2016

Test Date: 10/3/19

TEST EQUIPMENT LIST					
Description	Manufacturer	Model	ID Num	Cal Due	Last Cal
Amplifier, 100KHz to 1GHz, 32dB	HEWLET PACKARD	8447D	T64	6/25/2020	6/25/2019
Hybrid Antenna, 30MHz to 3GHz	SunAR rf motion	JB3	PRE0181574	8/1/2020	8/1/2019
Semianechoic Chamber K	TDK RF SOLUTIONS INC.	N/A	170329	5/26/2020	5/26/2019
EMI TEST RECEIVER	Rohde & Schwarz	ESW	PRE0179377	5/3/2020	5/3/2019
Antenna, Passive Loop 100 kHz - 30 MHz	Electro-Metrics	EM-6872	PRE0179467	5/31/2020	5/31/2019
Antenna, Passive Loop 30 Hz - 1 MHz	Electro-Metrics	EM-6871	PRE0179465	5/31/2020	5/31/2019
Antenna, Broadband Hybrid, 30MHz to 2000MHz	Sunol Sciences Corp.	JB3	T900	6/18/2020	6/18/2019
Amplifier, 9KHz to 1GHz, 32dB	SONOMA INSTRUMENT	310	170648	7/9/2020	7/9/2019
EMI TEST RECEIVER	Rohde & Schwarz	ESW	PRE0179376	2/14/2020	2/14/2019

UL SOFTWARE			
Radiated Software	UL	UL EMC	Ver 9.5, Sept 7, 2019

7. OCCUPIED BANDWIDTH

7.1. 20 dB BANDWIDTH

LIMITS

None; for reporting purposes only.

TEST PROCEDURE

The transmitter output is connected to the spectrum analyzer. The RBW is set to 10kHz. The VBW is set to 3 times the RBW. The sweep time is coupled. The spectrum analyzer internal 99% bandwidth function is utilized.

Note: Because the measured signal is CW-like, adjusting the RBW per C63.10 would not be practical since measured bandwidth will always follow the RBW and the result will be approximately twice the RBW.

RESULTS

Frequency (MHz)	20dB Bandwidth (KHz)
13.56	21.162

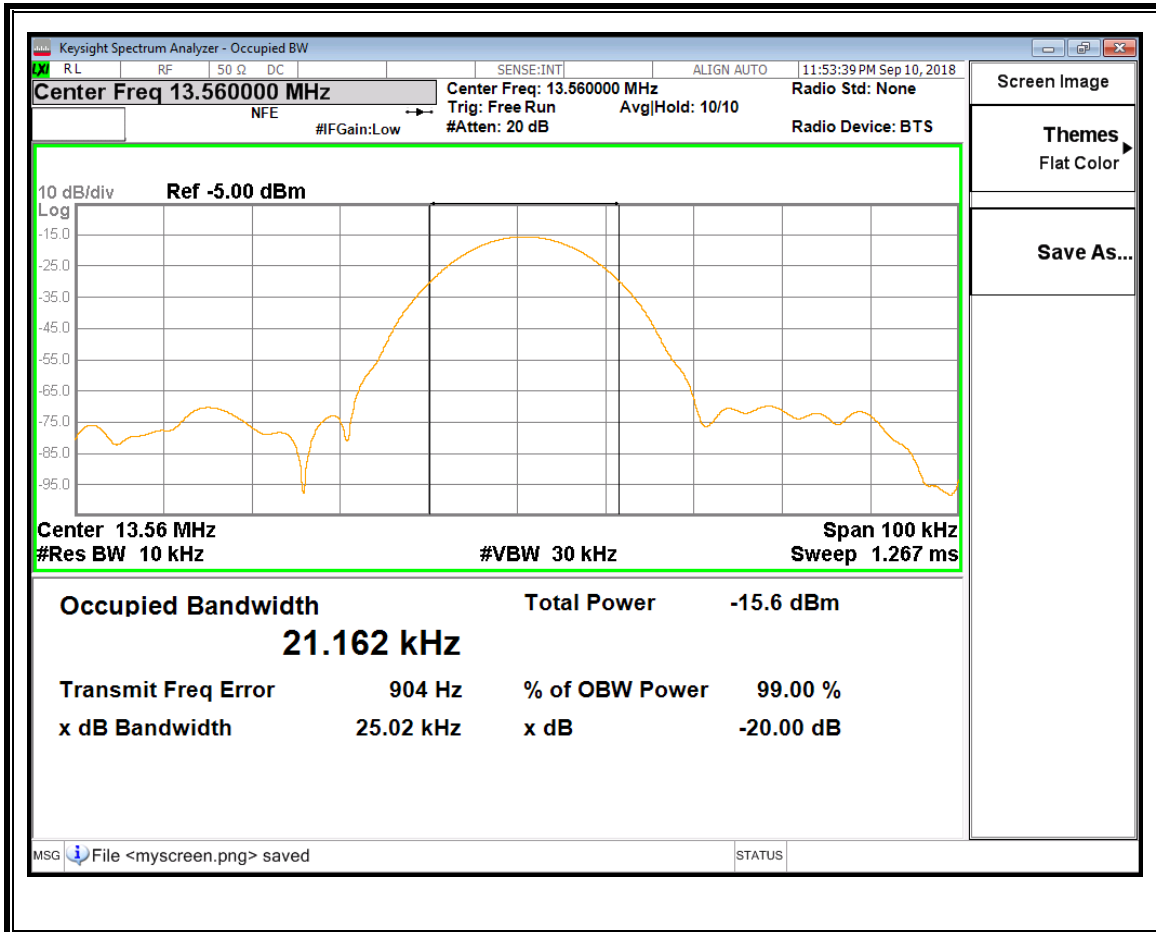

8. RADIATED EMISSION TEST RESULTS

8.1. LIMITS AND PROCEDURE

LIMIT

§15.225

(a) The field strength of any emissions within the band 13.553–13.567 MHz shall not exceed 15,848 microvolts/ meter at 30 meters.

(b) Within the bands 13.410–13.553 MHz and 13.567–13.710 MHz, the field strength of any emissions shall not exceed 334 microvolts/meter at 30 meters.

(c) Within the bands 13.110–13.410 MHz and 13.710–14.010 MHz the field strength of any emissions shall not exceed 106 microvolts/meter at 30 meters.

(d) The field strength of any emissions appearing outside of the 13.110– 14.010 MHz and shall not exceed the general radiated emission limits in § 15.209 as follows:

§15.209 (a) Except as provided elsewhere in this subpart, the emissions from an intentional radiator shall not exceed the field strength levels specified in the following table:

Limits for radiated disturbance of an intentional radiator		
Frequency range (MHz)	Limits (µV/m)	Measurement Distance (m)
0.009 – 0.490	2400 / F (kHz)	300
0.490 – 1.705	24000 / F (kHz)	30
1.705 – 30.0	30	30
30 – 88	100**	3
88 - 216	150**	3
216 – 960	200**	3
Above 960	500	3

** Except as provided in paragraph (g), fundamental emissions from intentional radiators operating under this section shall not be located in the frequency bands 54-72 MHz, 76-88 MHz, 174-216 MHz or 470-806 MHz. However, operation within these frequency bands is permitted under other sections of this part, e.g. §§ 15.231 and 15.241.

§15.209 (b) In the emission table above, the tighter limit applies at the band edges.

Formula for converting the filed strength from uV/m to dBuV/m is:

Limit (dBuV/m) = 20 log limit (uV/m)

In addition:

§15.209 (d) The emission limits shown the above table are based on measurements employing a CISPR quasi-peak detector except for the frequency bands 9-90 kHz, 110-490 kHz and above 1000 MHz. Radiated emissions limits in these three bands are based on measurements employing an average detector.

§15.209 (d) The provisions in §§ 15.225, measuring emissions at distances other than the distances specified in the above table, determining the frequency range over which radiated emissions are to be measured, and limiting peak emissions apply to all devices operated under this part.

TEST PROCEDURE

ANSI C63.10, 2013

The EUT is an intentional radiator that incorporates a digital device, the highest fundamental frequency generated or used in the device is 13.56 MHz; therefore, the frequency range was investigated from 0.15 MHz to the 10th harmonic of the highest fundamental frequency, or 1000 MHz, whichever is greater.

KDB 414788 OFS and Chamber Correlation Justification

Base on FCC 15.31 (f) (2): measurements may be performed at a distance closer than that specified in the regulations; however, an attempt should be made to avoid making measurements in the near field.

OFS and chamber correlation testing had been performed and chamber measured test result is the worst case test result.

RESULTS

8.2. FUNDAMENTAL AND SPURIOUS EMISSIONS (0.09 - 30 MHz)

8.2.1. FUNDAMENTAL – Without iPhone

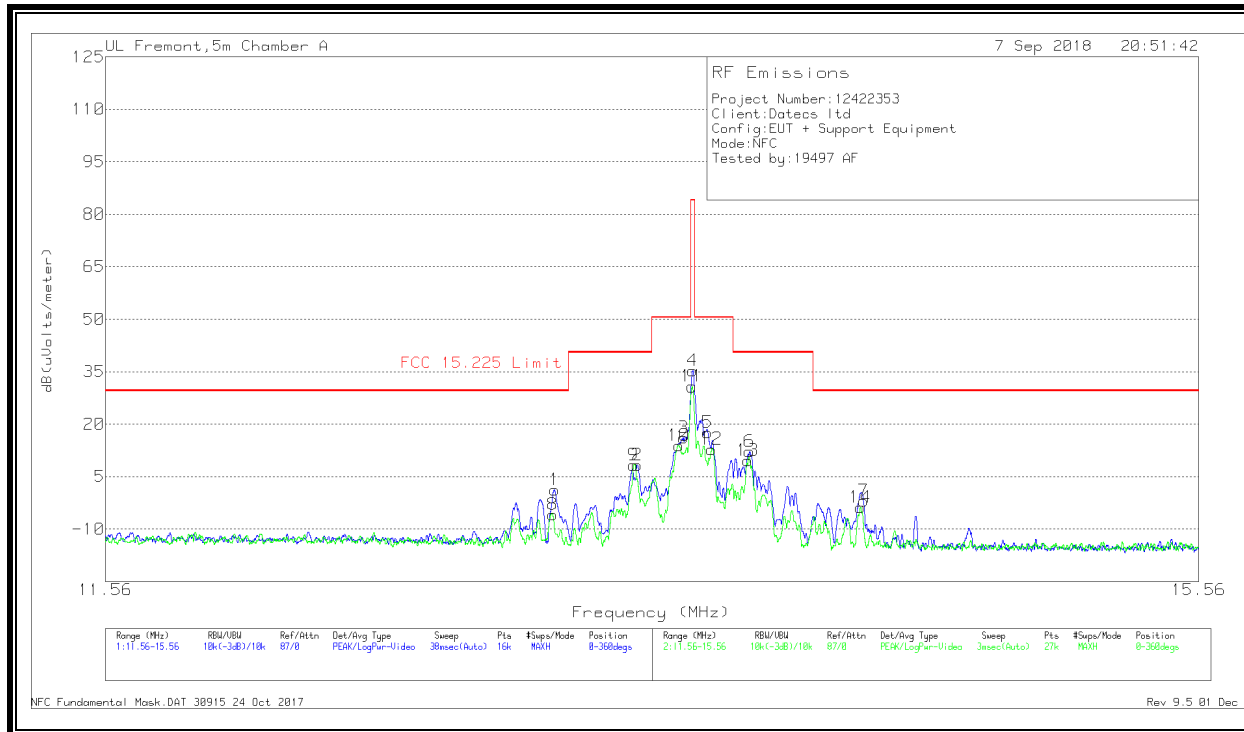

DATA

Trace Markers

Marker	Frequency (MHz)	Meter Reading (dBuV)	Det	Loop Antenna (dB/m)	Cbl (dB)	Dist Corr 30m	Corrected Reading dB(uVolts/meter)	FCC 15.225 Limit	PK Margin (dB)	Azimuth (Degs)
8	13.05391	18.97	Pk	14.6	.6	-40	-5.83	29.54	-35.37	0-360
1	13.0605	25.92	Pk	14.6	.6	-40	1.12	29.54	-28.42	0-360
9	13.34473	33.02	Pk	14.6	.6	-40	8.22	40.51	-32.29	0-360
2	13.35925	33.04	Pk	14.6	.6	-40	8.24	40.51	-32.27	0-360
10	13.50946	38.74	Pk	14.5	.6	-40	13.84	50.5	-36.66	0-360
3	13.52575	40.99	Pk	14.5	.6	-40	16.09	50.5	-34.41	0-360
11	*13.55874	55.63	Pk	14.5	.6	-40	30.73	84	-53.27	0-360
4	*13.56063	60.24	Pk	14.5	.6	-40	35.34	84	-48.66	0-360
5	13.61675	42.43	Pk	14.5	.6	-40	17.53	50.5	-32.97	0-360
12	13.63082	37.74	Pk	14.5	.6	-40	12.84	50.5	-37.66	0-360
13	13.76638	34.51	Pk	14.5	.5	-40	9.51	40.51	-31	0-360
6	13.77175	37.13	Pk	14.5	.5	-40	12.13	40.51	-28.38	0-360
14	14.19329	21.2	Pk	14.5	.5	-40	-3.8	29.54	-33.34	0-360
7	14.2045	23.06	Pk	14.5	.5	-40	-1.94	29.54	-31.48	0-360

* - Indicates fundamental frequency

Pk - Peak detector

8.2.1. FUNDAMENTAL – With iPhone

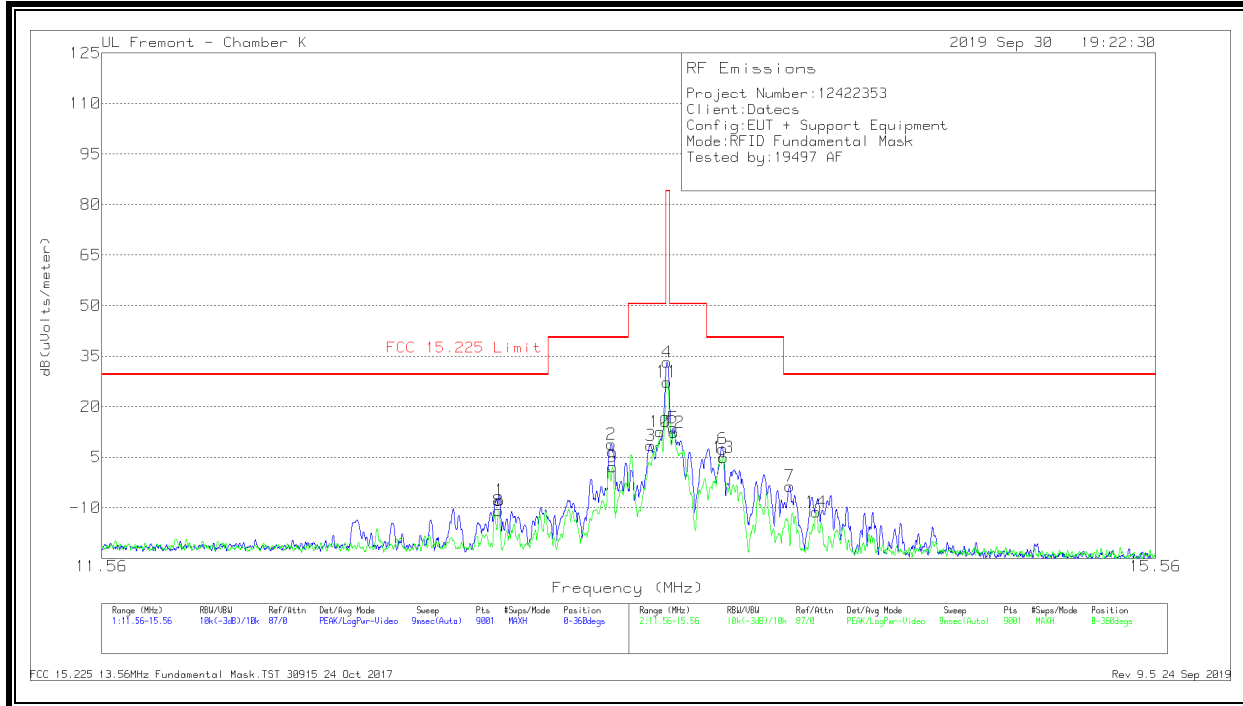

DATA

Trace Markers

Marker	Frequency (MHz)	Meter Reading (dBuV)	Det	Loop Antenna (ACF)	Cables w/ PRE0186650	Dist Corr 30m (dB) 40Log	Corrected Reading dB(uVolts/meter)	FCC 15.225 Limit	PK Margin (dB)	Azimuth (Degs)
1	12.93374	29.89	Pk	34.2	-31.8	-40	-7.71	29.54	-37.25	0-360
2	13.34577	46.48	Pk	34.2	-31.8	-40	8.88	40.51	-31.63	0-360
3	13.49584	46.04	Pk	34.2	-31.8	-40	8.44	50.5	-42.06	0-360
4	13.558	70.96	Pk	34.1	-31.8	-40	33.26	84	-50.74	0-360
5	13.58242	51.45	Pk	34.1	-31.8	-40	13.75	50.5	-36.75	0-360
6	13.7729	45.05	Pk	34.1	-31.7	-40	7.45	40.51	-33.06	0-360
7	14.03463	34.05	Pk	34.1	-31.7	-40	-3.55	29.54	-33.09	0-360
8	12.9293	26.75	Pk	34.2	-31.8	-40	-10.85	29.54	-40.39	0-360
9	13.35154	39.66	Pk	34.2	-31.8	-40	2.06	40.51	-38.45	0-360
10	13.53225	50.34	Pk	34.1	-31.8	-40	12.64	50.5	-37.86	0-360
11	13.558	65.07	Pk	34.1	-31.8	-40	27.37	84	-56.63	0-360
12	13.58331	50.09	Pk	34.1	-31.8	-40	12.39	50.5	-38.11	0-360
13	13.77423	42.53	Pk	34.1	-31.7	-40	4.93	40.51	-35.58	0-360
14	14.13964	26.41	Pk	34.1	-31.7	-40	-11.19	29.54	-40.73	0-360

Pk - Peak detector

8.2.1. SPURIOUS EMISSION (0.09 - 30 MHz) – Without iPhone

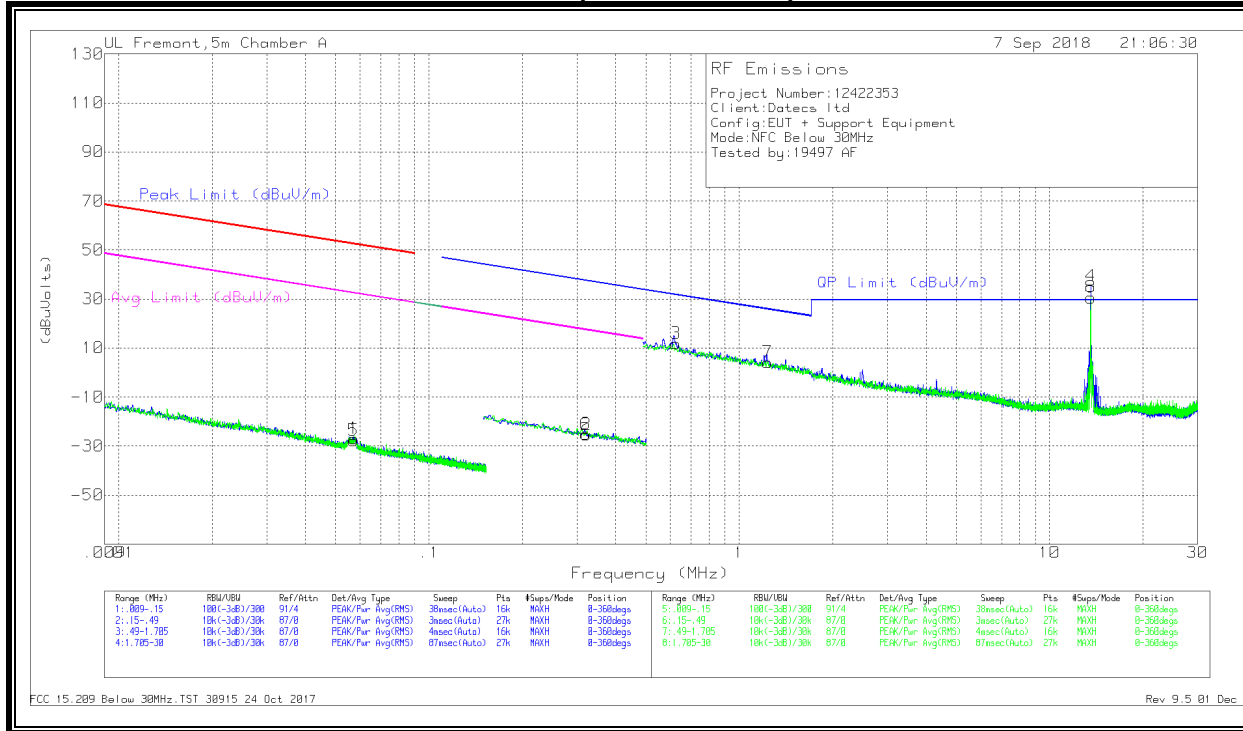

DATA

Trace Markers

Marker	Frequency (MHz)	Meter Reading (dBuV)	Det	Loop Antenna (dB/m)	Cbl (dB)	Dist Corr 300m	Corrected Reading (dBuVolts)	Peak Limit (dBuV/m)	Margin (dB)	Avg Limit (dBuV/m)	Margin (dB)	Peak Limit (dBuV/m)	Margin (dB)	Avg Limit (dBuV/m)	Margin (dB)	Azimuth (Degs)
5	.05707	37.71	Pk	14.4	.1	-80	-27.79	52.46	-80.25	32.46	-60.25	-	-	-	-	0-360
1	.0574	38.47	Pk	14.4	.1	-80	-27.03	52.41	-79.44	32.41	-59.44	-	-	-	-	0-360
6	.31983	40.9	Pk	13.8	.1	-80	-25.2	-	-	-	-	37.51	-62.71	17.51	-42.71	0-360
2	.32138	40.76	Pk	13.8	.1	-80	-25.34	-	-	-	-	37.47	-62.81	17.47	-42.81	0-360

Pk - Peak detector

Marker	Frequency (MHz)	Meter Reading (dBuV)	Det	Loop Antenna (dB/m)	Cbl (dB)	Dist Corr 30m	Corrected Reading (dBuVolts)	QP Limit (dBuV/m)	Margin (dB)	Peak Limit (dBuV/m)	Margin (dB)	Avg Limit (dBuV/m)	Margin (dB)	Azimuth (Degs)
3	.62574	37.7	Pk	14	.1	-40	11.8	31.68	-19.88	-	-	-	-	0-360
7	1.23514	29.5	Pk	14.3	.2	-40	4	25.79	-21.79	-	-	-	-	0-360
4	*13.55998	60.05	Pk	14.5	.6	-40	35.15	29.5	5.65	-	-	-	-	0-360
8	*13.55998	55.45	Pk	14.5	.6	-40	30.55	29.5	1.05	-	-	-	-	0-360

* - indicates fundamental frequency

Pk - Peak detector

8.2.1. SPURIOUS EMISSION (0.09 - 30 MHz) – With iPhone

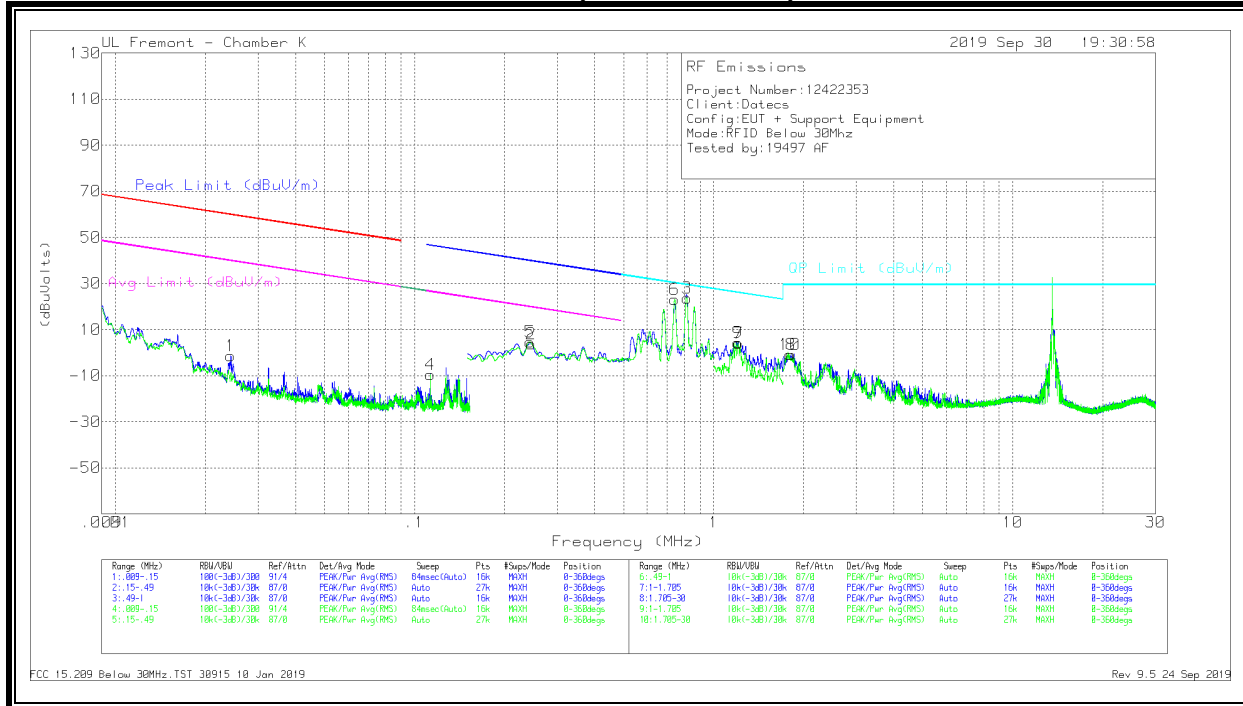

DATA

Trace Markers

Marker	Frequency (MHz)	Meter Reading (dBuV)	Det	Loop Antenna (dB/m)	Cbl (dB)	Dist Corr 300m	Corrected Reading (dBUVolts)	Peak Limit (dBUV/m)	Margin (dB)	Avg Limit (dBUV/m)	Margin (dB)	Peak Limit (dBUV/m)	Margin (dB)	Avg Limit (dBUV/m)	Margin (dB)	Azimuth (Degs)
1	.02433	12.38	Pk		58.3	-32.1	-40	-1.42	59.86	-61.28	39.86	-41.28	-	-	-	-
2	.24518	19.87	Pk		56.1	-32.1	-40	3.87	-	-	-	-	39.83	-35.96	19.83	-15.96
4	.11311	7.22	Pk		55.5	-32.2	-40	-9.48	-	-	-	-	46.56	-56.04	26.56	-36.04
5	.24294	20.73	Pk		56.1	-32.1	-40	4.73	-	-	-	-	39.91	-35.18	19.91	-15.18

Pk - Peak detector

Marker	Frequency (MHz)	Meter Reading (dBuV)	Det	Loop Antenna (dB/m)	Cbl (dB)	Dist Corr 30m	Corrected Reading (dBUVolts)	QP Limit (dBUV/m)	Margin (dB)	Azimuth (Degs)
3	.81477	39.75	Pk	56.1	-32.1	-40	23.75	29.4	-5.65	0-360
6	.74077	39.04	Pk	56.1	-32.1	-40	23.04	30.22	-7.18	0-360
7	1.20975	30.38	Pk	45.7	-32.1	-40	3.98	25.97	-21.99	0-360
8	1.81504	28.55	Pk	42.6	-32	-40	-8.5	29.5	-30.35	0-360
9	1.20522	30.85	Pk	45.7	-32.1	-40	4.45	26	-21.55	0-360
10	1.79513	28.59	Pk	42.7	-32	-40	-7.1	29.5	-30.21	0-360

* - indicates fundamental frequency

Pk - Peak detector

8.3. TX SPURIOUS EMISSION 30 TO 1000 MHz

8.3.1. Without iPhone

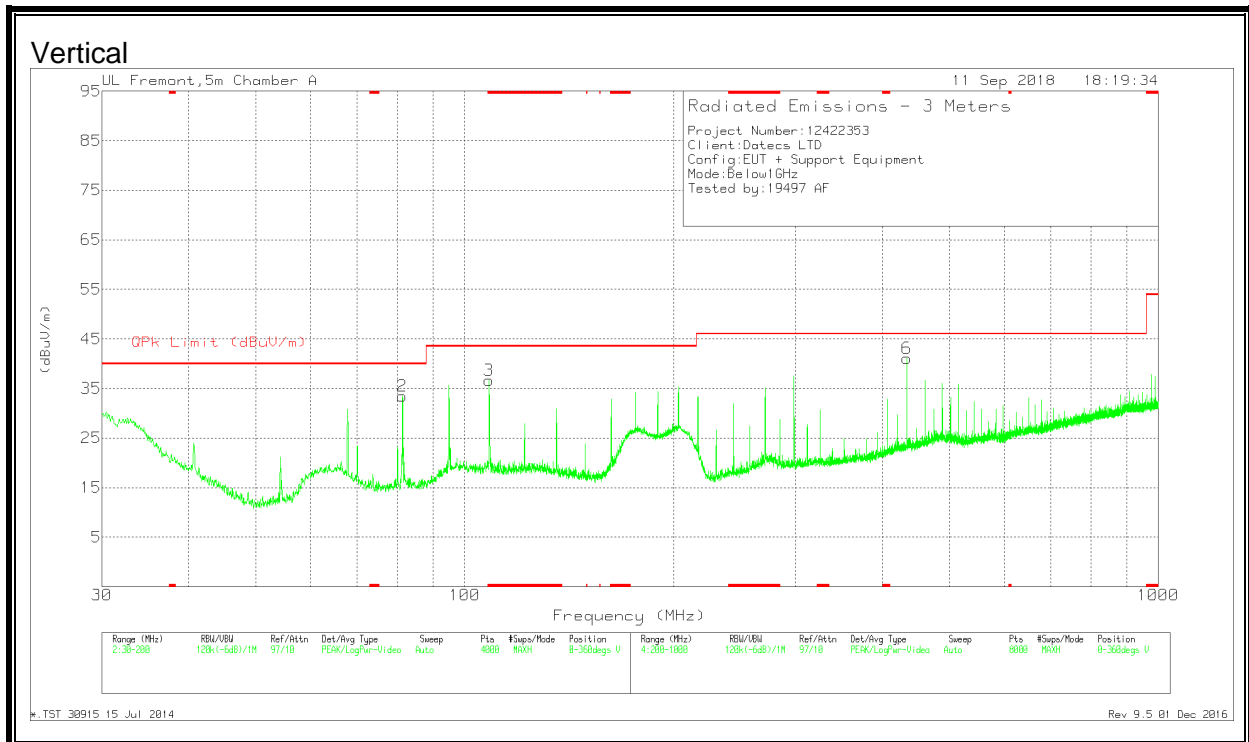
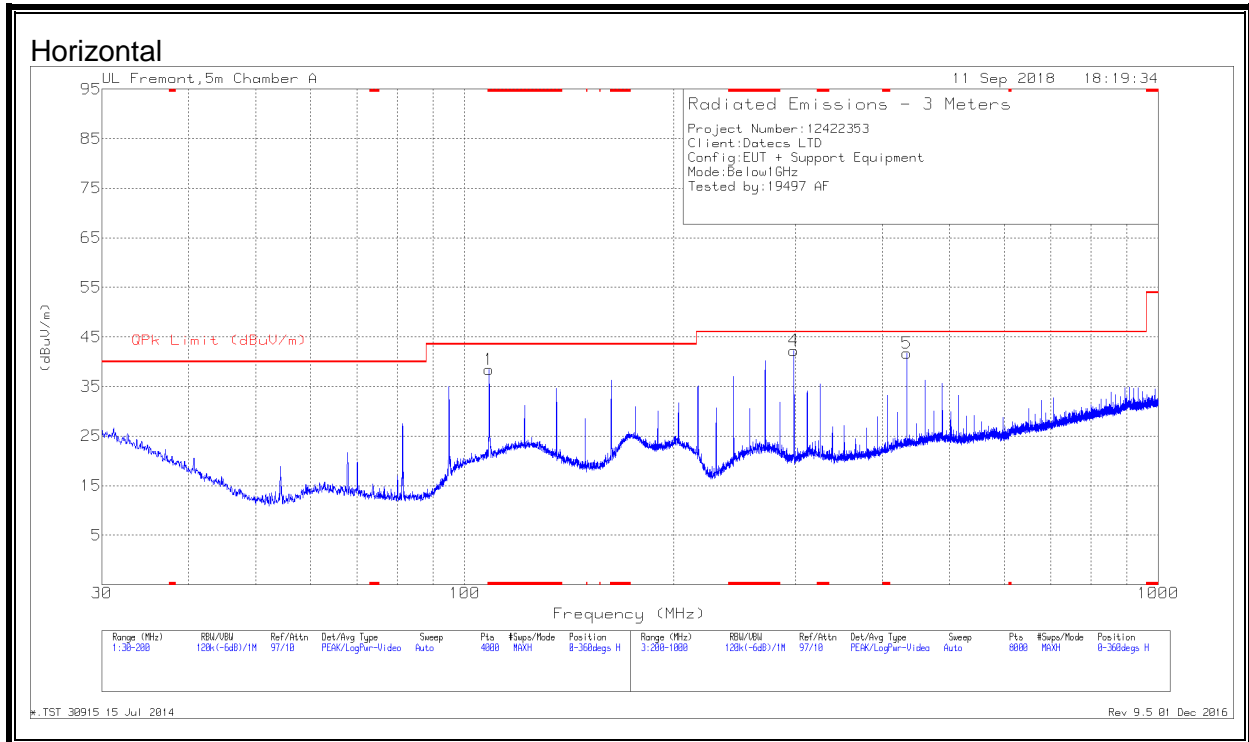

DATA

Marker	Frequency (MHz)	Meter Reading (dBuV)	Det	AF T130 (dB/m)	Amp/Cbl (dB/m)	Corrected Reading (dBuV/m)	QPk Limit (dBuV/m)	Margin (dB)	Azimuth (Degs)	Height (cm)	Polarity
1	* 108.4753	48.37	Pk	16.4	-26.3	38.47	43.52	-5.05	0-360	300	H
	* 108.4887	47.57	Qp	16.4	-26.3	37.67	43.52	-5.85	284	282	H
3	* 108.4753	46.52	Pk	16.4	-26.3	36.62	43.52	-6.9	0-360	100	V
2	81.3533	48.66	Pk	11.4	-26.6	33.46	40	-6.54	0-360	100	V
4	298.3128	49.59	Pk	17.3	-24.6	42.29	46.02	-3.73	0-360	101	H
	298.3315	49.19	Qp	17.3	-24.6	41.89	46.02	-4.13	25	110	H
5	433.9304	46.27	Pk	20.6	-25.1	41.77	46.02	-4.25	0-360	101	H
	433.9371	44.43	Qp	20.6	-25.1	39.93	46.02	-6.09	260	108	V
6	433.9304	45.55	Pk	20.6	-25.1	41.05	46.02	-4.97	0-360	101	V
	433.9438	44.94	Qp	20.6	-25.1	40.44	46.02	-5.58	344	103	H

* - indicates frequency in CFR47 Pt 15 / IC RSS-Restricted Band

Pk - Peak detector

Qp - Quasi-Peak detector

8.3.1. With iPhone

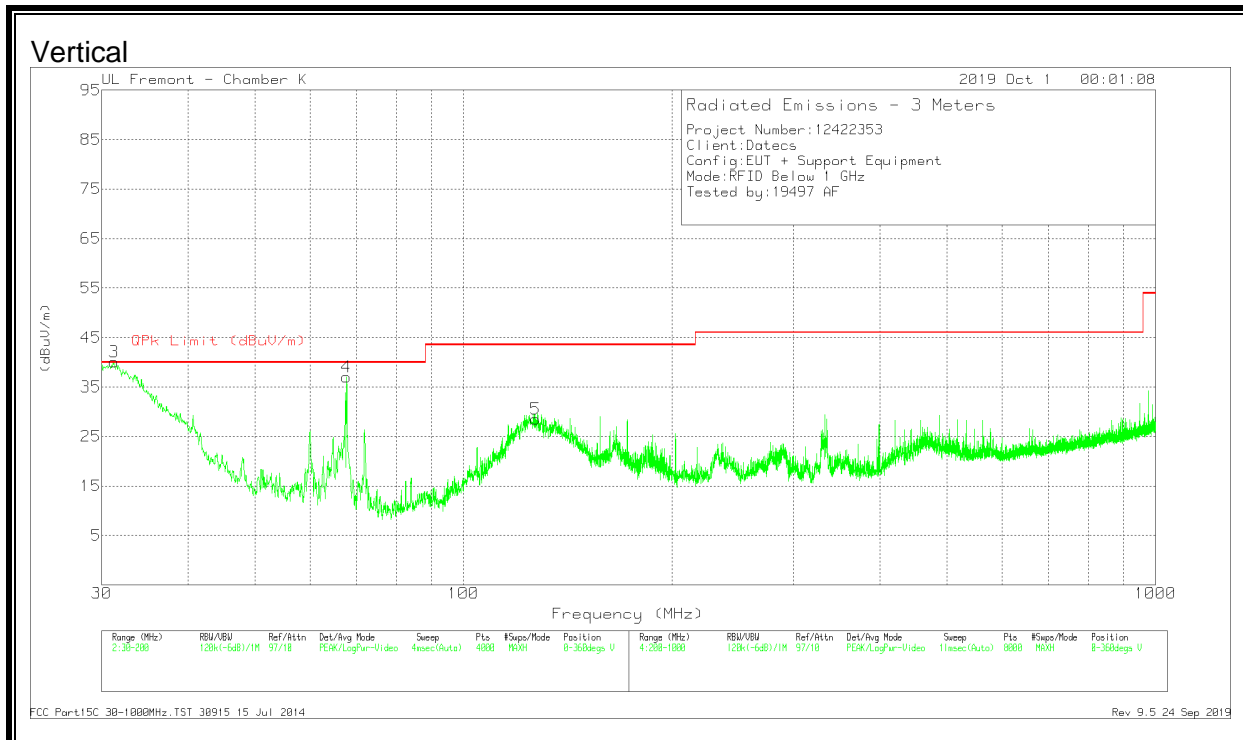
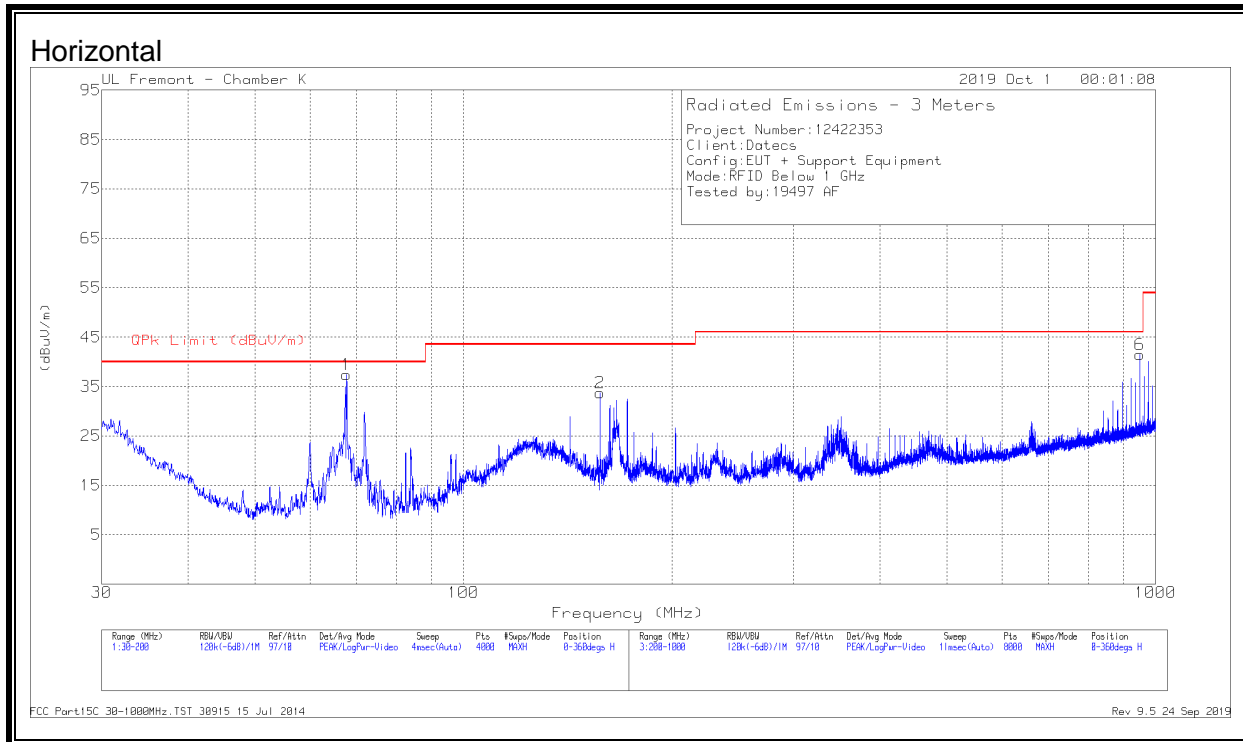

DATA

Trace Markers

Marker	Frequency (MHz)	Meter Reading (dBuV)	Det	AF PRE0184052 (dB/m)	Amp/Cbl (dB)	Corrected Reading (dBuV/m)	QPk Limit (dBuV/m)	Margin (dB)	Azimuth (Degs)	Height (cm)	Polarity
1	67.7923	54.67	Pk	13.9	-31.2	37.37	40	-2.63	0-360	299	H
2	157.4905	45.99	Pk	18.2	-30.5	33.69	43.52	-9.83	0-360	199	H
3	31.2753	45.81	Pk	25.8	-31.5	40.11	40	.11	0-360	95	V
4	67.7923	54.28	Pk	13.9	-31.2	36.98	40	-3.02	0-360	95	V
5	* 127.0526	39.65	Pk	19.6	-30.7	28.55	43.52	-14.97	0-360	95	V
6	949.2974	39.37	Pk	28.8	-26.7	41.47	46.02	-4.55	0-360	99	H

* - indicates frequency in CFR47 Pt 15 / IC RSS-Restricted Band
 Pk - Peak detector

Radiated Emissions

Frequency (MHz)	Meter Reading (dBuV)	Det	AF PRE0184052 (dB/m)	Amp/Cbl (dB)	Corrected Reading (dBuV/m)	QPk Limit (dBuV/m)	Margin (dB)	Azimuth (Degs)	Height (cm)	Polarity
67.8081	55.6	Pk	13.9	-31.2	38.3	40	-1.7	83	245	H
67.8081	52.95	Qp	13.9	-31.2	35.65	40	-4.35	83	245	H
31.2457	44.92	Pk	25.8	-31.5	39.22	40	-.78	270	207	V
31.2457	40.52	Qp	25.8	-31.5	34.82	40	-5.18	270	207	V
67.7995	55.32	Pk	13.9	-31.2	38.02	40	-1.98	10	97	V
67.7995	53.03	Qp	13.9	-31.2	35.73	40	-4.27	10	97	V
67.7995	52.66	Qp	13.9	-31.2	35.36	40	-4.64	10	97	V
949.2447	40.27	Pk	28.8	-26.7	42.37	46.02	-3.65	308	156	H
949.2447	35.79	Qp	28.8	-26.7	37.89	46.02	-8.13	308	156	H

* - indicates frequency in CFR47 Pt 15 / IC RSS-Restricted Band
 Pk - Peak detector
 Qp - Quasi-Peak detector

9. FREQUENCY STABILITY

LIMIT

§15.225 (e) The frequency tolerance of the carrier signal shall be maintained within $\pm 0.01\%$ of the operating frequency, over a temperature variation of -20 degrees to +50 degrees C at normal supply voltage, and for a variation in the primary supply voltage from 85% to 115% of the rated supply voltage at a temperature of 20 degrees C. For battery operated equipment, the equipment tests shall be performed using a new battery.

TEST PROCEDURE

ANSI C63.10-2013 Clause 6.8

RESULTS

Tested By:	19497 AF
Date:	9/11/2018

No non-compliance noted.

Reference Frequency: EUT Channel 13.56 MHz @ 20°C Limit: ± 100 ppm = 1.356 kHz										
Power Supply	Envir. Temp	Frequency Deviation Measured with Time Elapse								
(Vdc)	(°C)	Startup (MHz)	Delta (ppm)	@ 2 mins (MHz)	Delta (ppm)	@ 5 mins (MHz)	Delta (ppm)	@ 10 mins (MHz)	Delta (ppm)	Limit (ppm)
5.00	50	13.5599608	-0.052	13.5599611	-0.074	13.5599610	-0.066	13.5599610	-0.066	± 100
5.00	40	13.5599606	-0.037	13.5599607	-0.044	13.5599607	-0.044	13.5599607	-0.044	± 100
5.00	30	13.5599602	-0.007	13.5599601	0.000	13.5599600	0.007	13.5599602	-0.007	± 100
5.00	20	13.5599601	0.000	13.5599601	0.000	13.5599601	0.000	13.5599601	0.000	± 100
5.00	10	13.5599625	-0.177	13.5599624	-0.170	13.5599623	-0.162	13.5599623	-0.162	± 100
5.00	0	13.5599619	-0.133	13.5599621	-0.147	13.5599620	-0.140	13.5599621	-0.147	± 100
5.00	-10	13.5599614	-0.096	13.5599612	-0.081	13.5599611	-0.074	13.5599613	-0.088	± 100
4.25	20	13.5599610	-0.066	13.5599610	-0.066	13.5599613	-0.088	13.5599607	-0.044	± 100
4.37	20	13.5599605	-0.029	13.5599602	-0.007	13.5599606	-0.037	13.5599603	-0.015	± 100

10. AC MAINS LINE CONDUCTED EMISSIONS

LIMITS

§15.207

(a) Except as shown in paragraphs (b) and (c) of this section, for an intentional radiator that is designed to be connected to the public utility (AC) power line, the radio frequency voltage that is conducted back onto the AC power line on any frequency or frequencies, within the band 150 kHz to 30 MHz, shall not exceed the limits in the following table, as measured using a 50 μ H/50 ohms line impedance stabilization network (LISN). Compliance with the provisions of this paragraph shall be based on the measurement of the radio frequency voltage between each power line and ground at the power terminal. The lower limit applies at the band edges.

Frequency range (MHz)	Limits (dB μ V)	
	Quasi-peak	Average
0.15 to 0.50	66 to 56	56 to 46
0.50 to 5	56	46
5 to 30	60	50

Notes:
1. The lower limit shall apply at the transition frequencies
2. The limit decreases linearly with the logarithm of the frequency in the range 0.15 MHz to 0.50 MHz.

TEST PROCEDURE

ANSI C63.10:2013

RESULTS

No non-compliance noted:

10.1. NORMAL OPERATION WITH ANTENNA

LINE 1 RESULTS

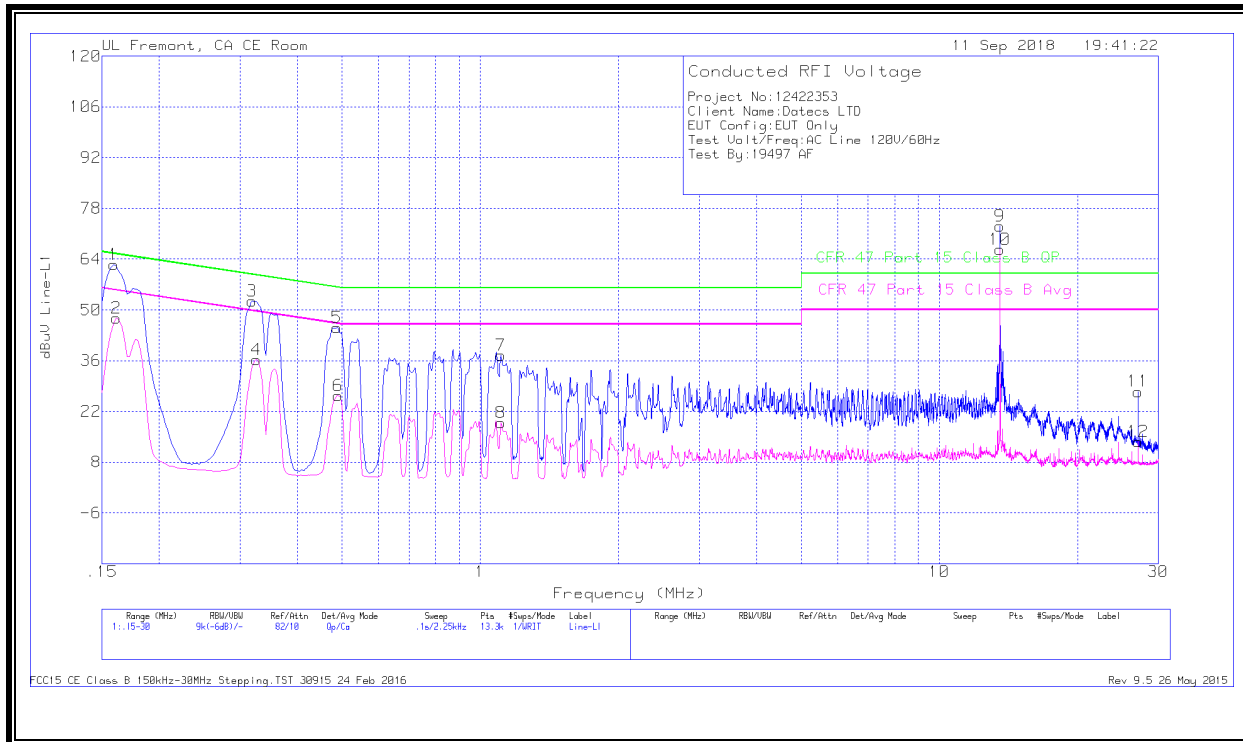

WORST EMISSIONS

Trace Markers

Range 1: Line-L1 .15 - 30MHz											
Marker	Frequency (MHz)	Meter Reading (dBuV)	Det	LISN L1	LC Cables C1&C3	Limiter (dB)	Corrected Reading dBuV	CFR 47 Part 15 Class B QP	QP Margin (dB)	CFR 47 Part 15 Class B Avg	Av(CISPR)Margin (dB)
1	.159	52.33	Qp	.1	0	10.1	62.53	65.52	-2.99	-	-
2	.16125	37.6	Ca	.1	0	10.1	47.8	-	-	55.4	-7.6
3	.31875	42.32	Qp	0	0	10.1	52.42	59.74	-7.32	-	-
4	.3255	26.19	Ca	0	0	10.1	36.29	-	-	49.57	-13.28
5	.4875	35.02	Qp	0	0	10.1	45.12	56.21	-11.09	-	-
6	.48975	16.23	Ca	0	0	10.1	26.33	-	-	46.17	-19.84
7	1.1085	27.3	Qp	0	.1	10.1	37.5	56	-18.5	-	-
8	1.11075	8.74	Ca	0	.1	10.1	18.94	-	-	46	-27.06
9	13.56	62.59	Qp	.1	.2	10.2	73.09	60	13.09	-	-
10	13.56	56.19	Ca	.1	.2	10.2	66.69	-	-	50	16.69
11	27.1208	16.49	Qp	.1	.4	10.5	27.49	60	-32.51	-	-
12	27.1208	2.63	Ca	.1	.4	10.5	13.63	-	-	50	-36.37

Qp - Quasi-Peak detector

Ca - CISPR average detection

Note: Markers 9 and 10 are the 13.56MHz NFC Fundamental

LINE 2 RESULTS

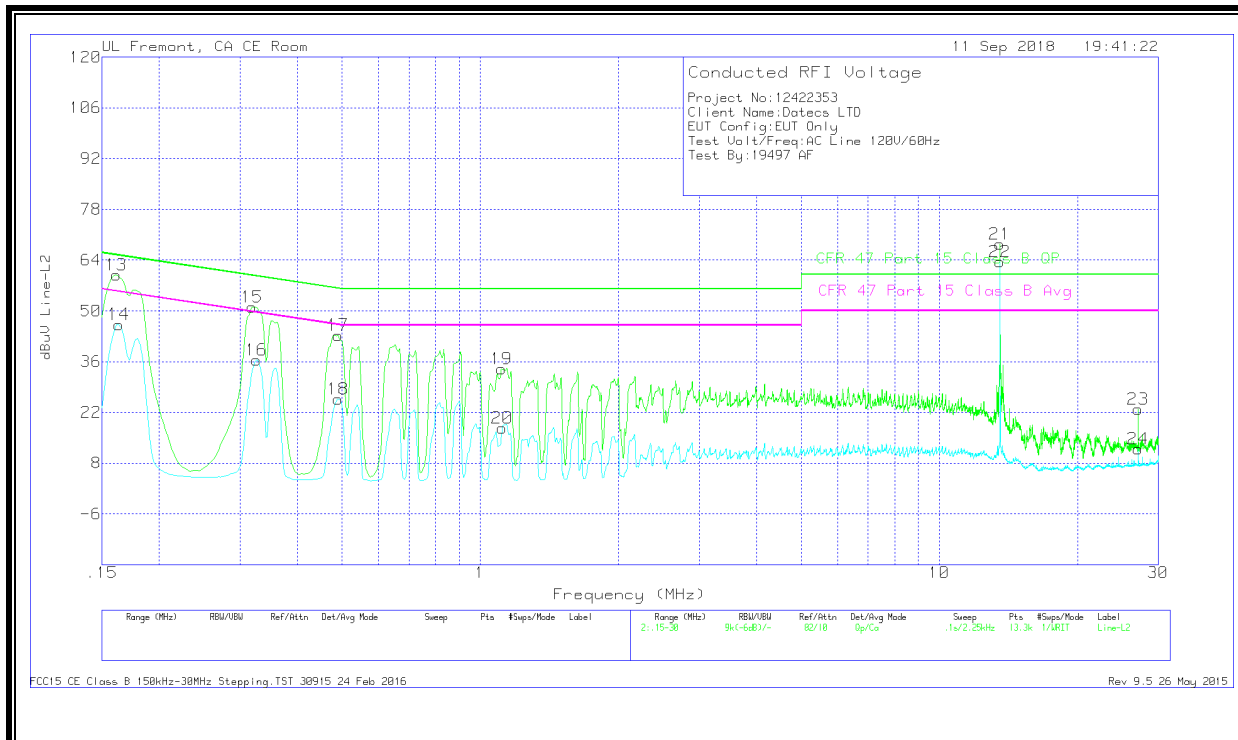

WORST EMISSIONS

Trace Markers

Range 2: Line-L2 .15 - 30MHz											
Marker	Frequency (MHz)	Meter Reading (dBuV)	Det	LISN L2	LC Cables C2&C3	Limiter (dB)	Corrected Reading dBuV	CFR 47 Part 15 Class B QP	QP Margin (dB)	CFR 47 Part 15 Class B Avg	Av(CISPR)Margin (dB)
13	.16125	49.65	Qp	.1	0	10.1	59.85	65.4	-5.55	-	-
14	.1635	36.06	Ca	.1	0	10.1	46.26	-	-	55.28	-9.02
15	.31875	41	Qp	0	0	10.1	51.1	59.74	-8.64	-	-
16	.3255	26.34	Ca	0	0	10.1	36.44	-	-	49.57	-13.13
17	.48975	33.2	Qp	0	0	10.1	43.3	56.17	-12.87	-	-
18	.48975	15.49	Ca	0	0	10.1	25.59	-	-	46.17	-20.58
19	1.113	23.73	Qp	0	.1	10.1	33.93	56	-22.07	-	-
20	1.1175	7.45	Ca	0	.1	10.1	17.65	-	-	46	-28.35
21	13.56	57.99	Qp	.1	.2	10.2	68.49	60	8.49	-	-
22	13.56	53.03	Ca	.1	.2	10.2	63.53	-	-	50	-13.53
23	27.1208	11.95	Qp	.1	.4	10.5	22.95	60	-37.05	-	-
24	27.1208	1	Ca	.1	.4	10.5	12	-	-	50	-38

Qp - Quasi-Peak detector

Ca - CISPR average detection

Note: Markers 21 and 22 are the 13.56MHz NFC Fundamental

10.1.1. NORMAL OPERATION WITH ANTENNA PORT TERMINATED

LINE 1 RESULTS

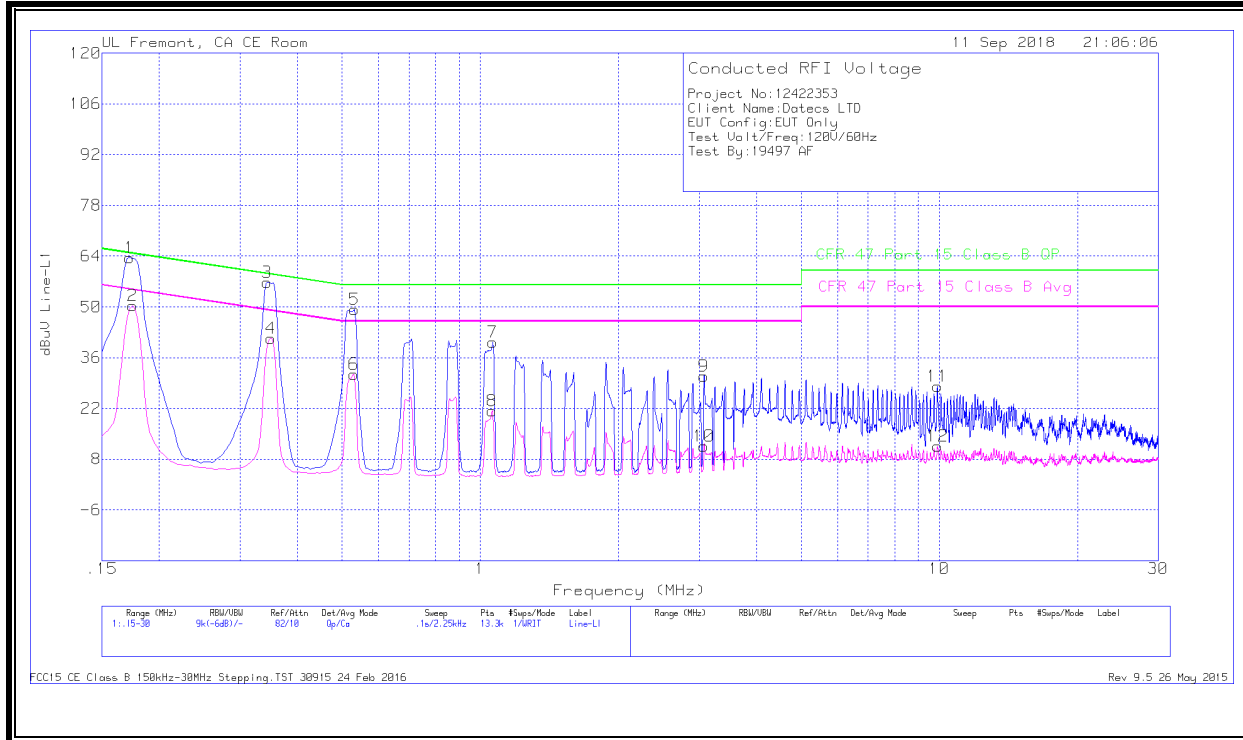

WORST EMISSIONS

Trace Markers

Range 1: Line-L1 .15 - 30MHz											
Marker	Frequency (MHz)	Meter Reading (dBuV)	Det	LISN L1	LC Cables C1&C3	Limiter (dB)	Corrected Reading dBuV	CFR 47 Part 15 Class B QP	QP Margin (dB)	CFR 47 Part 15 Class B Avg	Av(CISPR)Margin (dB)
1	.1725	53.49	Qp	0	0	10.1	63.59	64.84	-1.25	-	-
2	.17475	40.28	Ca	0	0	10.1	50.38	-	-	54.73	-4.35
3	.3435	46.74	Qp	0	0	10.1	56.84	59.12	-2.28	-	-
4	.35025	31.26	Ca	0	0	10.1	41.36	-	-	48.96	-7.6
5	.5325	39.17	Qp	0	0	10.1	49.27	56	-6.73	-	-
6	.53025	21.38	Ca	0	0	10.1	31.48	-	-	46	-14.52
7	1.06575	30	Qp	0	.1	10.1	40.2	56	-15.8	-	-
8	1.06125	11.11	Ca	0	.1	10.1	21.31	-	-	46	-24.69
9	3.07275	20.64	Qp	0	.1	10.1	30.84	56	-25.16	-	-
10	3.07275	1.31	Ca	0	.1	10.1	11.51	-	-	46	-34.49
11	9.91275	17.69	Qp	0	.2	10.2	28.09	60	-31.91	-	-
12	9.91275	1.22	Ca	0	.2	10.2	11.62	-	-	50	-38.38

Qp - Quasi-Peak detector
 Ca - CISPR average detection

LINE 2 RESULTS

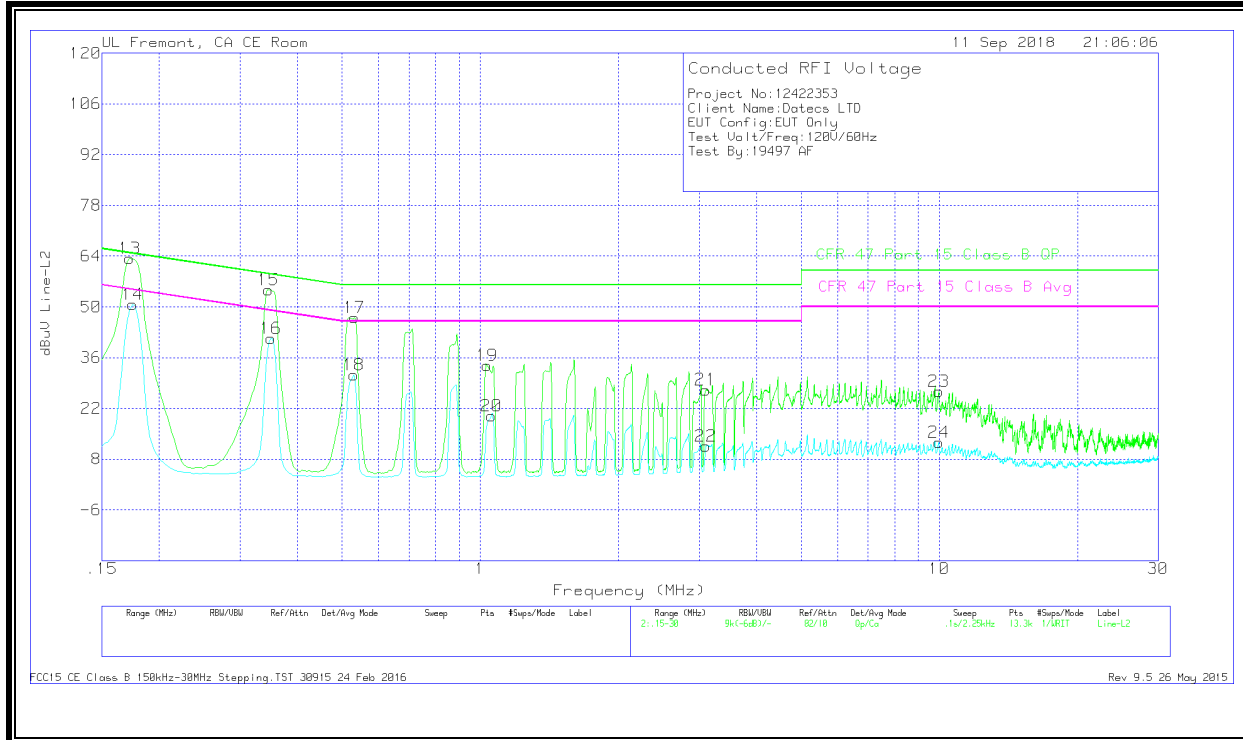

WORST EMISSIONS

Trace Markers

Range 2: Line-L2 .15 - 30MHz											
Marker	Frequency (MHz)	Meter Reading (dBuV)	Det	LISN L2	LC Cables C2&C3	Limiter (dB)	Corrected Reading dBuV	CFR 47 Part 15 Class B QP	QP Margin (dB)	CFR 47 Part 15 Class B Avg	Av(CISPR)Margin (dB)
13	.1725	53.24	Qp	0	0	10.1	63.34	64.84	-1.5	-	-
14	.17475	40.59	Ca	0	0	10.1	50.69	-	-	54.73	-4.04
15	.34575	44.66	Qp	0	0	10.1	54.76	59.06	-4.3	-	-
16	.35025	31.19	Ca	0	0	10.1	41.29	-	-	48.96	-7.67
17	.5325	36.99	Qp	0	0	10.1	47.09	56	-8.91	-	-
18	.53025	21.08	Ca	0	0	10.1	31.18	-	-	46	-14.82
19	1.03425	23.64	Qp	0	.1	10.1	33.84	56	-22.16	-	-
20	1.05675	9.72	Ca	0	.1	10.1	19.92	-	-	46	-26.08
21	3.09975	16.94	Qp	0	.1	10.1	27.14	56	-28.86	-	-
22	3.102	1.42	Ca	0	.1	10.1	11.62	-	-	46	-34.38
23	9.97125	16.34	Qp	0	.2	10.2	26.74	60	-33.26	-	-
24	9.97125	2.27	Ca	0	.2	10.2	12.67	-	-	50	-37.33

Qp - Quasi-Peak detector
 Ca - CISPR average detection