



Report Number:	12422353-E2V2
Issue Date:	7/23/2019
Product Name:	Payment terminal with magnetic card reader and contactless card reader
Model Number:	INFINEA TAB M LITE

Electromagnetic Compatibility Test Report

For

**DATECS Ltd.
DEPARTMENT OF INNOVATIVE TECHNOLOGIES
4 “Datecs” Str.
1592 SOFIA, BULGARIA**

Test Report Details

Tests Performed By: UL Verification Services
47173 Benicia Street, Fremont, CA 94538

Tests Performed For: DATECS Ltd.
DEPARTMENT OF INNOVATIVE TECHNOLOGIES
4 "Datecs" Str.
1592 SOFIA, BULGARIA

Issue Date: 7/23/2019

Product Name: Payment terminal with magnetic card reader and contactless card reader.

Model Number: INFINEA TAB M LITE

Sample Serial Number: 2618900001

Product Standards: FCC 47 CFR PART 15 SUBPART B

Testing Start Date: September 7, 2018

Date Testing Complete: September 11, 2018

Overall Results: Compliant

UL LLC reports apply only to the specific samples tested under stated test conditions. All samples tested were in good operating condition throughout the entire test program. It is the manufacturer's responsibility to assure that additional production units of this model are manufactured with identical electrical and mechanical components. UL LLC shall have no liability for any deductions, inferences or generalizations drawn by the client or others from UL LLC issued reports. This report must not be used by the client to claim product certification, approval, or endorsement by NVLAP, NIST, any agency of the Federal Government, or any agency of any government.

*This report may contain test results that are not covered by the NVLAP or A2LA accreditation. The scope of accreditation is limited to the specific tests that are listed on the NVLAP and/or A2LA websites referenced at the end of this report.

Report Directory

- 1.0 Summary5
 - 1.1 Deviations from standard test methods5
 - 1.2 Device Modifications Necessary for Compliance5
 - 1.3 Applicable Standards5
 - 1.4 Summary of Tests6
- 2.0 CALIBRATION AND UNCERTAINTY7
 - 2.1 Measuring Instrument Calibration7
 - 2.2 Sample Calculation7
 - 2.3 Measurement Uncertainty7
- 3.0 GENERAL - Product Description9
 - 3.1 Equipment Description9
 - 3.2 Equipment Marking Plate9
 - 3.3 Device Configuration During Test 10
 - 3.3.1 Equipment Used During Test: 10
 - 3.3.2 Input/Output Ports: 10
 - 3.3.3 EUT Internal Operating Frequencies: 10
 - 3.3.4 Power Interface: 10
 - 3.3.5 Software and Firmware 11
 - 3.4 Block Diagram: 11
 - 3.5 EUT Configurations 12
 - 3.6 Rational for EUT Configurations 12
- 4.0 APPLICABLE EMISSIONS LIMITS AND TEST RESULTS 13
 - 4.1 Test Conditions and Results - MAINS TERMINAL - CONDUCTED EMISSIONS 14
 - 4.2 Test Conditions and Results - RADIATED EMISSIONS 19
- Appendix A 24
 - Facilities, Accreditations and Authorizations 24

Report Revision History

Revision Date	Revision Version	Description	Revised By	Revision Reviewed By
9/17/18	V1	Initial Issue		
7/23/19	V2	Report revised based on reviewer's comments.	Bobby Bayani	Dan Corona

1.0 Summary

The tests listed in the Summary of Testing section of this report have been performed and the results recorded by UL LLC in accordance with the procedures stated in each test requirement and specification. The applicant determined the list of tests performed were applicable to the Equipment Under Test. As a result, the subject product has been verified to comply or not comply as noted in the Summary of Testing with each test specification. The test results relate only to the items tested.

1.1 Deviations from standard test methods

None

1.2 Device Modifications Necessary for Compliance

None

1.3 Applicable Standards

Standard
FCC 47 CFR PART 15 SUBPART B

1.4 Summary of Tests

This product is considered Class B

Requirement – Test	Result (Compliant / Non-Compliant)
CONDUCTED EMISSIONS	Compliant
RADIATED EMISSIONS	Compliant

Reviewed By:

Prepared By:

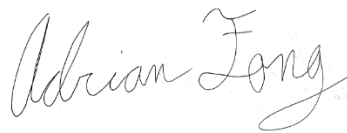

Bobby Bayani
Lead Project Engineer
UL Verification Service Inc.

Adrian Fong
Laboratory Engineer
UL Verification Services Inc.

Approved & Released For
UL Verification Services Inc By:



Dan Corona
Operations Leader
UL Verification Service Inc.

Any information and documentation involving UL Mark services are provided on behalf of UL LLC (UL) or any authorized licensee of UL.

2.0 CALIBRATION AND UNCERTAINTY

2.1 Measuring Instrument Calibration

All test equipment and test accessories are calibrated on a regular basis. The maximum time between calibrations is one year or the manufacturers' recommendation, whichever is less.

All test equipment calibrations are traceable to the National Institute of Standards and Technology (NIST); therefore, all test data recorded in this report is traceable to NIST.

2.2 Sample Calculation

RADIATED EMISSIONS

Where relevant, the following sample calculation is provided:

Field Strength (dBuV/m) = Measured Voltage (dBuV) + Antenna Factor (dB/m) + Cable Loss (dB) – Preamp Gain (dB)

$$36.5 \text{ dBuV} + 18.7 \text{ dB/m} + 0.6 \text{ dB} - 26.9 \text{ dB} = 28.9 \text{ dBuV/m}$$

MAINS CONDUCTED EMISSIONS

Where relevant, the following sample calculation is provided:

Final Voltage (dBuV) = Measured Voltage (dBuV) + Cable Loss (dB) + Limiter Factor (dB) + LISN Insertion Loss.

$$36.5 \text{ dBuV} + 0 \text{ dB} + 10.1 \text{ dB} + 0 \text{ dB} = 46.6 \text{ dBuV}$$

2.3 Measurement Uncertainty

Where relevant, the following measurement uncertainty levels have been estimated for tests performed on the apparatus:

PARAMETER	UNCERTAINTY
Worst Case Conducted Disturbance, 9KHz to 0.15 MHz	3.84 dB
Worst Case Conducted Disturbance, 0.15 to 30 MHz	3.65 dB
Worst Case Radiated Disturbance, 9KHz to 30 MHz	3.15 dB
Worst Case Radiated Disturbance, 30 to 1000 MHz	5.36 dB
Worst Case Radiated Disturbance, 1000 to 18000 MHz	4.32 dB
Worst Case Radiated Disturbance, 18000 to 26000 MHz	4.45 dB
Worst Case Radiated Disturbance, 26000 to 40000 MHz	5.24 dB

PARAMETER	UNCERTAINTY	
	UL Verification Services	EMCE Engineering
Power Line Conducted Emission	3.65 dB	N/A
Radiated Emission, 30 to 1000 MHz	5.36 dB	± 4.98 dB
Radiated Emission, 1 to 6 GHz	4.32 dB	N/A

Uncertainty figures are valid to a confidence level of 95%.

3.0 GENERAL - Product Description

3.1 Equipment Description

Payment terminal with magnetic card reader and contactless card reader.

3.2 Equipment Marking Plate

Not Provided

3.3 Device Configuration During Test

Mode #	Description
1	Normal

3.3.1 Equipment Used During Test:

Use	Product Type	Manufacturer	Model	Comments
EUT	Magnetic Card Reader	Datecs LTD	INFINEA TAB M LITE	None
AE	Laptop	Lenovo	T460	Support Equipment

Note: EUT - Equipment Under Test, AE - Auxiliary/Associated Equipment, or SIM - Simulator (Not Subjected to Test)

3.3.2 Input/Output Ports:

Port #	Name	Type*	Cable Max. >3m (Y/N)	Cable Shielded (Y/N)	Comments
0	Lightning Connector	DC	N	N	Connects to iPhone
1	USB Communication	DC	N	N	Connects to charger or laptop

*Note:
 AC = AC Power Port DC = DC Power Port N/E = Non-Electrical
 I/O = Signal Input or Output Port (Not Involved in Process Control)
 TP = Telecommunication Ports

3.3.3 EUT Internal Operating Frequencies:

Frequency (MHz)	Description
12.000MHz	Main CPU
32.768KHz	Main CPU
27.12MHz	NFC Chip

3.3.4 Power Interface:

Mode # /Rated	Voltage (V)	Current (A)	Power (W)	Frequency (DC/AC-Hz)	Phases (#)	Comments
Rated	5	-	-	DC	Single	Battery

3.3.5 Software and Firmware

The test utility software used during testing was IRETest.exe, rev. 2.0.3.

3.4 Block Diagram:

The diagram below illustrates the configuration of the equipment above.

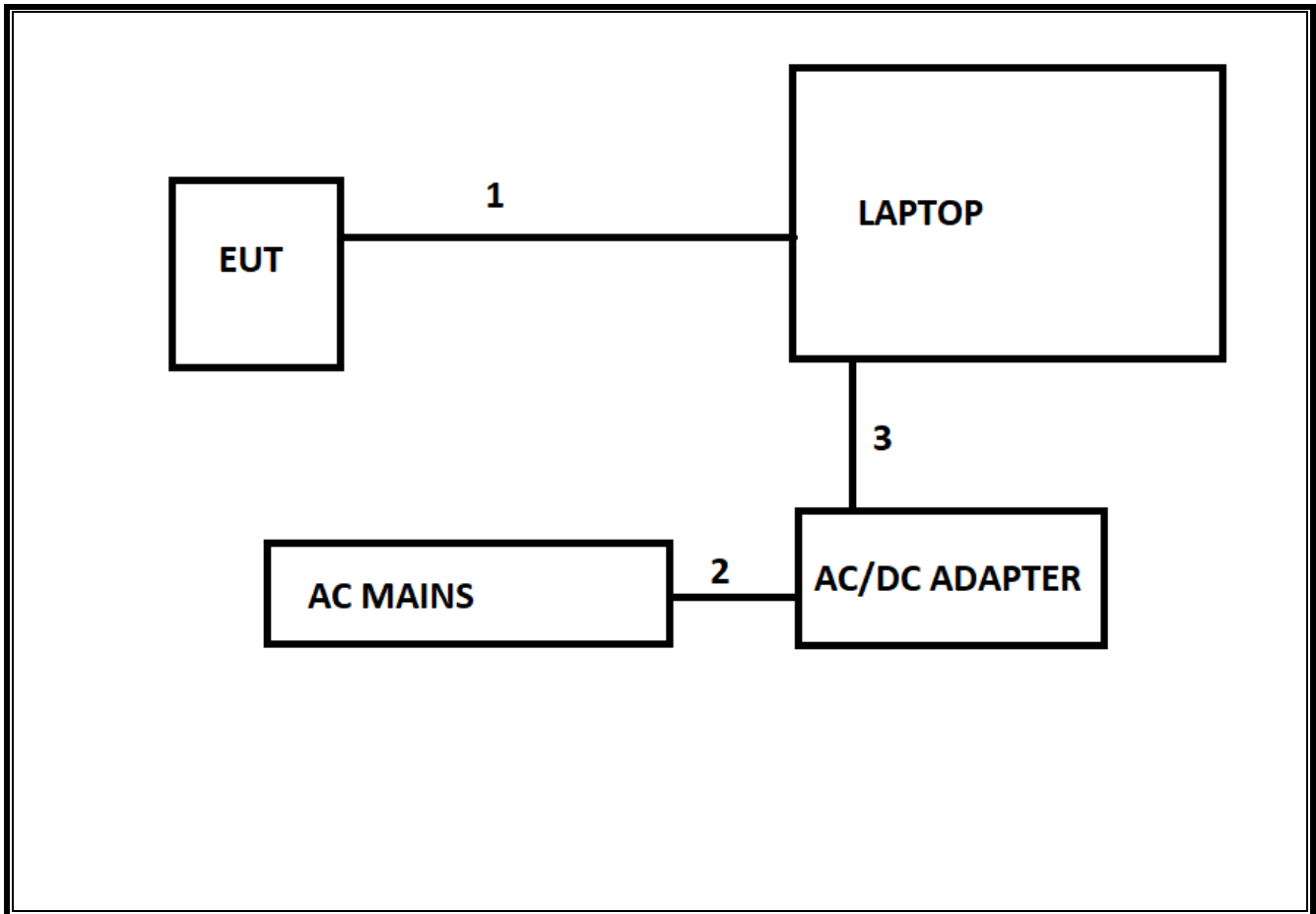

3.5 EUT Configurations

Configuration #	Description
1	The EUT was operated in normal condition.

3.6 Rational for EUT Configurations

Configuration #	Description
1	The selected EUT configuration was chosen to maximize emissions

4.0 APPLICABLE EMISSIONS LIMITS AND TEST RESULTS

The emissions tests were performed according to following regulations:

----- United States -----

Code of Federal Regulations Title 47	Part 15, Subpart B, Radio Frequency Devices – Unintentional Radiators
--------------------------------------	---

----- International -----

EMC Directive:	EMC - 2014/30/EU (OJ C 293 of 2014-04-12)
----------------	---

Unless specified otherwise in the individual Methods, the tests shall be conducted under the following ambient conditions. Confirmation of these conditions shall be verified at the time the test is conducted.

Ambient Temperature, °C	22.5 ± 2.5	Relative Humidity, %	45 ± 15	Barometric Pressure, mBar	950 ± 150
-------------------------	------------	----------------------	---------	---------------------------	-----------

4.1 Test Conditions and Results - MAINS TERMINAL - CONDUCTED EMISSIONS

Test Description	Measurements were made on a ground plane. All power was connected to the system through Artificial Mains Network (AMN). Conducted voltage measurements on mains lines were made at the output of the AMN.	
Standards	FCC Part 15 Subpart B	
Test Engineer	19497 AF	
	Frequency range on each side of line	Measurement Point
Fully configured sample scanned over the following frequency range	150kHz to 30MHz	Mains
Limits - Class A		
Frequency (MHz)	Limit (dB μ V)	
	Quasi-Peak	Average
0.15-0.5	79	66
0.5-30	73	60
Limits - Class B		
Frequency (MHz)	Limit (dB μ V)	
	Quasi-Peak	Average
0.15-0.5	66 to 56	56 to 46
0.5-5	56	46
5-30	60	50
Supplementary information: None		

Conducted Emissions EUT Configuration Settings

Power Interface Mode #	EUT Configurations Mode #	EUT Operation Mode #
Rated	1	1
Supplementary information: None		

Conducted Emissions Test Equipment

Test Equipment List					
Description	Manufacturer	Model	Local ID (T No.)	Cal Date	Cal Due
EMI Test Receiver	Rohde&Schwarz	ESR26	PRE0176493	2/21/2019	2/21/2017
Signal Condition Unit	Schaffner	CCN1000-1	133	8/08/2019	8/08/2018
AC Power source	Schaffner	NSG1007	134	8/08/2019	8/08/2018
L.I.S.N	FCC INC.	FCC LISN 50/250	1310	6/15/2018	6/15/2019

Results – 120 V, 60 Hz

Conducted Emissions Graph

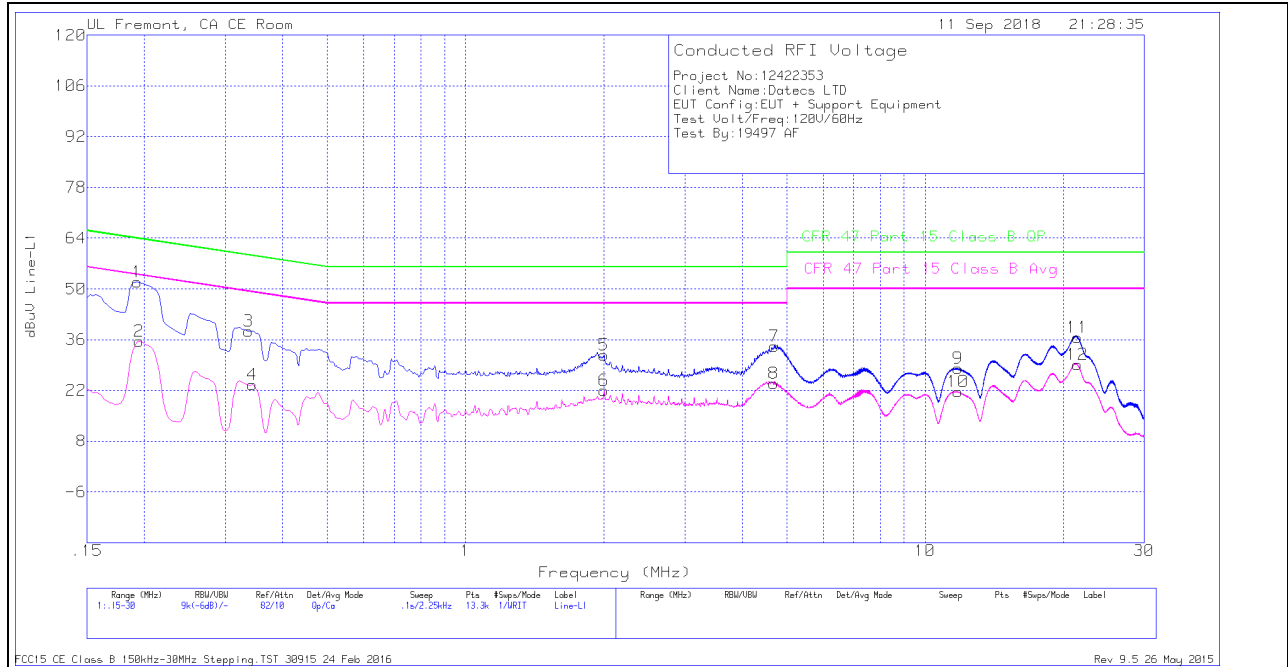

Line 1

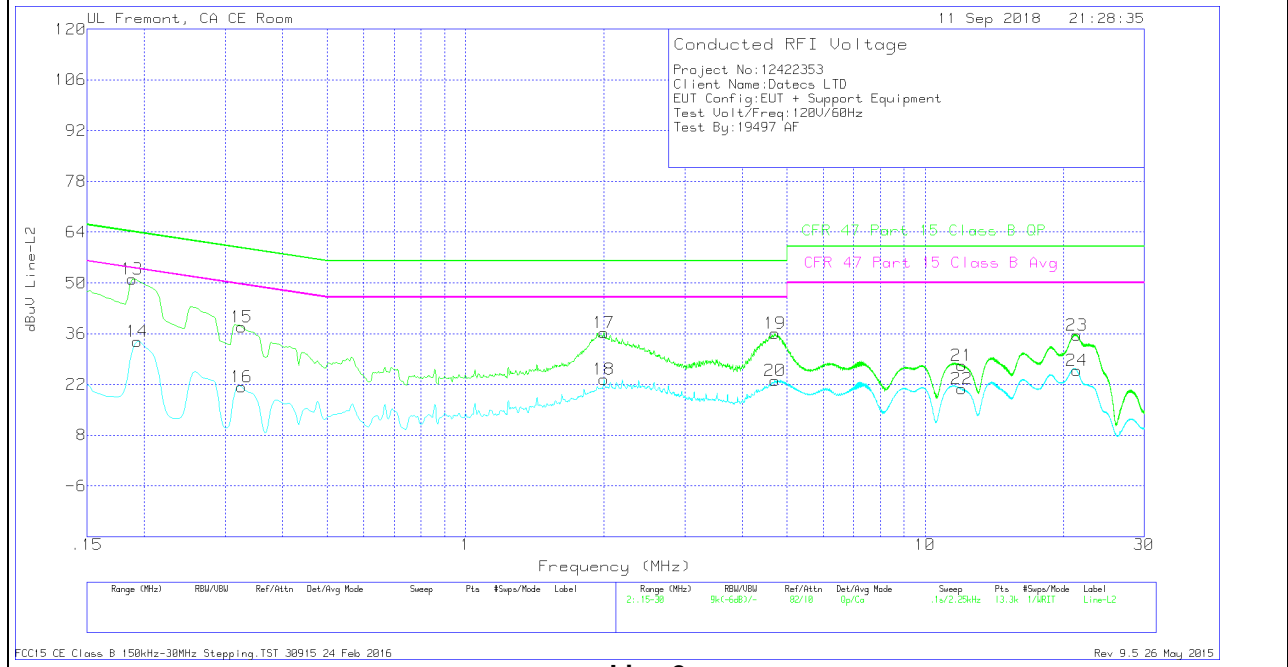

Line 2

Conducted Emissions Data Points

Line-L1 .15 - 30MHz

Range 1: Line-L1 .15 - 30MHz											
Marker	Frequency (MHz)	Meter Reading (dBuV)	Det	LISN L1	LC Cables C1&C3	Limiter (dB)	Corrected Reading dBuV	CFR 47 Part 15 Class B QP	QP Margin (dB)	CFR 47 Part 15 Class B Avg	Av(CISPR)Margin (dB)
1	.19275	41.82	Qp	0	0	10.1	51.92	63.92	-12	-	-
2	.195	25.5	Ca	0	0	10.1	35.6	-	-	53.82	-18.22
3	.33675	28.32	Qp	0	0	10.1	38.42	59.28	-20.86	-	-
4	.3435	13.4	Ca	0	0	10.1	23.5	-	-	49.12	-25.62
5	2.00175	21.47	Qp	0	.1	10.1	31.67	56	-24.33	-	-
6	2.00175	11.79	Ca	0	.1	10.1	21.99	-	-	46	-24.01
7	4.695	23.93	Qp	0	.1	10.1	34.13	56	-21.87	-	-
8	4.6905	13.78	Ca	0	.1	10.1	23.98	-	-	46	-22.02
9	11.80275	17.56	Qp	.1	.2	10.2	28.06	60	-31.94	-	-
10	11.805	11.11	Ca	.1	.2	10.2	21.61	-	-	50	-28.39
11	21.46875	25.87	Qp	.1	.3	10.4	36.67	60	-23.33	-	-
12	21.48	18.3	Ca	.1	.3	10.4	29.1	-	-	50	-20.9

Qp - Quasi-Peak detector

Ca - CISPR average detection

Line-L2 .15 - 30MHz

Range 2: Line-L2 .15 - 30MHz											
Marker	Frequency (MHz)	Meter Reading (dBuV)	Det	LISN L2	LC Cables C2&C3	Limiter (dB)	Corrected Reading dBuV	CFR 47 Part 15 Class B QP	QP Margin (dB)	CFR 47 Part 15 Class B Avg	Av(CISPR)Margin (dB)
13	.18825	40.92	Qp	0	0	10.1	51.02	64.11	-13.09	-	-
14	.19275	23.74	Ca	0	0	10.1	33.84	-	-	53.92	-20.08
15	.3255	27.74	Qp	0	0	10.1	37.84	59.57	-21.73	-	-
16	.3255	11.18	Ca	0	0	10.1	21.28	-	-	49.57	-28.29
17	2.00175	26.1	Qp	0	.1	10.1	36.3	56	-19.7	-	-
18	2.00175	13.25	Ca	0	.1	10.1	23.45	-	-	46	-22.55
19	4.7085	25.85	Qp	0	.1	10.1	36.05	56	-19.95	-	-
20	4.7085	12.93	Ca	0	.1	10.1	23.13	-	-	46	-22.87
21	12.03113	16.69	Qp	.1	.2	10.2	27.19	60	-32.81	-	-
22	12.02775	10.24	Ca	.1	.2	10.2	20.74	-	-	50	-29.26
23	21.399	24.8	Qp	.1	.3	10.4	35.6	60	-24.4	-	-
24	21.39225	15.08	Ca	.1	.3	10.4	25.88	-	-	50	-24.12

Qp - Quasi-Peak detector

Ca - CISPR average detection

4.2 Test Conditions and Results - RADIATED EMISSIONS

Test Description	Measurements were made in a 3-meter/10-meter semi-anechoic chamber that complies to CISPR 16/ANSI C63.4. Preliminary (peak) measurements were performed at an antenna to EUT separation distance of 3 meter/10-meter. The EUT was rotated 360° about its azimuth with the receive antenna located at various heights in both horizontal and vertical polarities. Final measurements (quasi-peak or average as noted) were then performed by rotating the EUT 360° and adjusting the receive antenna height from 1 to 4-meters. All frequencies were investigated in both horizontal and vertical antenna polarity, where applicable.	
Standards	FCC Part 15 Subpart B	
Test Engineer	19497 AF	
	Frequency range	Measurement Point
Fully configured sample scanned over the following frequency range	30MHz – 40 GHz	(3 meter/10 meter measurement distance)
Limits - Class B		
Frequency (MHz)	Limit (dBµV/m)	
CISPR Limits for radiated disturbance of Class B ITE at measuring distance of 10 m		
	Quasi-Peak	Average
30-230	30	NA
230-1000	37	NA
FCC Limits for radiated disturbance of Class B ITE at measuring distance of 3 m		
30-88	40	NA
88-216	43.5	NA
216-960	46	NA
Above 960	54	NA
	Peak	Average
Above 1 GHz	74	54
CISPR Limits for radiated disturbance of Class B ITE at measuring distance of 3 m		
	Peak	Average
1000-3000	70	50
3000-6000	74	54
Supplementary information: None		

Radiated Emissions EUT Configuration Settings

Power Interface Mode #	EUT Configurations Mode #	EUT Operation Mode #
Rated	1	1
Supplementary information: None		

Radiated Emissions Test Equipment

Test Equipment List					
TEST EQUIPMENT LIST	Manufacturer	Model	Local ID (T No.)	Cal Due	Last Cal
Description	Manufacturer	Model	ID Num	Cal Due	Last Cal
Antenna, Broadband Hybrid, 30MHz to 2000MHz	Sunol Sciences Corp.	JB1	T130	10/16/2018	10/16/2017
Semianechoic Chamber A	TDK RF SOLUTIONS INC.	N/A	T1199	6/12/2019	6/12/2018
Spectrum Analyzer	Agilent (Keysight) Technologies	N9030A	T818	6/12/2019	6/12/2018
Spectrum Analyzer, PXA, 3Hz to 44GHz	Agilent (Keysight) Technologies	N9030A	T1466	04/16/2019	04/16/2018
Amplifier, 100KHz to 1GHz, 32dB	Agilent (Keysight) Technologies	8447D	T15	10/16/2018	10/16/2017

RADIATED EMISSIONS 30 TO 1000 MHz (WORST-CASE CONFIGURATION)

Radiated Emissions Graph

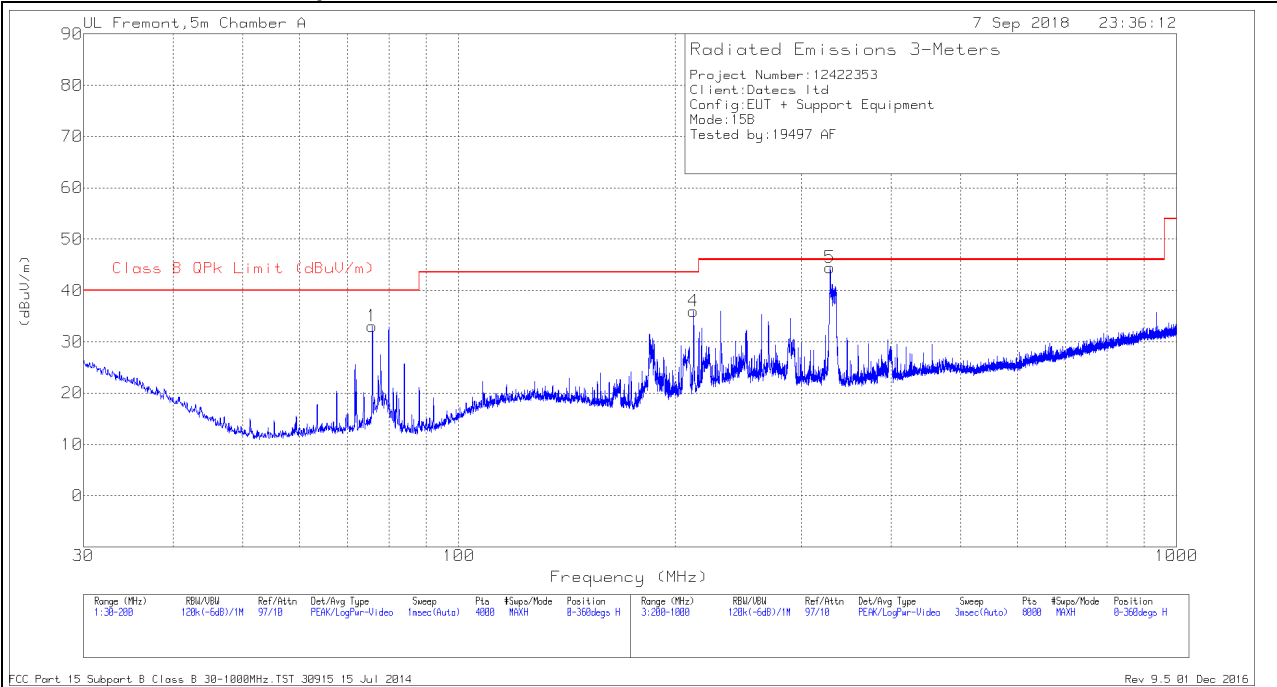

HORIZONTAL



VERTICAL PLOTS

Radiated Emissions Data Points

Trace Markers

Marker	Frequency (MHz)	Meter Reading (dBuV)	Det	AF T130 (dB/m)	Amp/Cbl (dB/m)	Corrected Reading (dBuV/m)	Class B QPk Limit (dBuV/m)	Margin (dB)	Azimuth (Degs)	Height (cm)	Polarity
1	75.7843	47.88	Pk	11.9	-26.7	33.08	40	-6.92	0-360	200	H
2	75.7843	40.49	Pk	11.9	-26.7	25.69	40	-14.31	0-360	100	V
3	185.2077	39.24	Pk	15.1	-25.5	28.84	43.52	-14.68	0-360	100	V
4	212.3016	46.61	Pk	14.5	-25.1	36.01	43.52	-7.51	0-360	101	H
5	328.8167	51.32	Pk	17.9	-24.7	44.52	46.02	-1.5	0-360	101	H
6	329.2168	44.35	Pk	17.9	-24.7	37.55	46.02	-8.47	0-360	101	V

Pk - Peak detector

Radiated Emissions

Frequency (MHz)	Meter Reading (dBuV)	Det	AF T130 (dB/m)	Amp/Cbl (dB/m)	Corrected Reading (dBuV/m)	Class B QPk Limit (dBuV/m)	Margin (dB)	Azimuth (Degs)	Height (cm)	Polarity
328.9981	35.92	Qp	17.9	-24.7	29.12	46.02	-16.9	318	102	H

Qp - Quasi-Peak detector

Appendix A**Facilities, Accreditations and Authorizations**

NVLAP Lab code: 200065-0

NVLAP: The National Institute of Standards and Technology (NIST) administers the National Voluntary Laboratory Accreditation Program (NVLAP). NVLAP is comprised of laboratory accreditation programs (LAPs) which are established on the basis of requests and demonstrated need. Each LAP includes specific calibration and/or test standards and related methods and protocols assembled to satisfy the unique needs for accreditation in a field of testing or calibration. NVLAP accredits public and private laboratories based on evaluation of their technical qualifications and competence to carry out specific calibrations or tests. Accreditation criteria are established in accordance with the U.S. Code of Federal Regulations (CFR, Title 15, Part 285), NVLAP Procedures and General Requirements, and encompass the requirements of ISO/IEC 17025. For a full scope listing see <http://ts.nist.gov/standards/scopes/1004140.htm>



FCC: Details of the measurement facilities used for these tests have been filed with the Federal Communications Commission's Laboratory in Columbia, Maryland (Ref. No. 91044).



Industry Canada Industrie Canada

Industry of Canada: Accredited by Industry Canada for performance of radiated measurements. Our test site complies with RSP 100, Issue 7, Section 3.3. File #: IC 2180



VCCI: Accepted as an Associate Member to the VCCI. The measurement facilities detailed in this test report have been registered in accordance with Regulations for Voluntary Control Measures, Article 8. Registration Nos.: Radiated Emissions R-621, Conducted Emissions C-642.



ICASA: ICASA (Independent Communications Authority of South Africa) has appointed UL as a Designated Test Laboratory to test Telecommunications equipment for type approval in compliance with CISPR 22 to assist in fulfilling its mandate under section 54(1) of the Telecommunications Act, 1996 (Act 103 of 1996).
NIST/CAB: Validated by the European Commission as a U.S. Conformity Assessment Body (CAB) of the U.S.-EU



Mutual Recognition Agreement (MRA) for the Electromagnetic Compatibility - Council Directive 2004/108/EC, Annex III (2-3). Also validated for the Telecommunication Equipment-Council Directive 99/5/EC, Annex III and IV, Identification Number: 0983.

NIST/CAB: Provisioned to act as a U.S. Conformity Assessment Body (CAB) under Appendix B, Phase I Procedures, of the Asia Pacific Economic Cooperation (APEC) MRA between the American Institute in Taiwan (AIT) and the United States. Our laboratory is considered qualified to test equipment subject to the applicable EMC regulations of the Chinese Taipei Bureau of Standards, Metrology and Inspection (BSMI) which require testing to CNS 13438 (CISPR 22).

NIST/CAB: Recognized by the Infocomm Development Authority of Singapore (IDA) under the Asia Pacific Economic Cooperation Mutual Recognition Agreement (APEC MRA). Our laboratory is provisionally designated to act as a Conformity Assessment Body (CAB) under Appendix B, Phase I Procedures, of the APEC MRA. Our scope of designation includes IDA TS EMC (CISPR 22), IEC 61000-4-2, -4-3, -4-4, -4-5, and -4-6

The test sites and measurement facilities used to collect data are located at 47173 and 47266 Benicia Street, and 47658 Kato Road, Fremont, California, USA. Line conducted emissions are measured only at the 47173 address. The following table identifies which facilities were utilized for radiated emission measurements documented in this report. Specific facilities are also identified in the test results sections.

47173 Benicia Street	47266 Benicia Street	47658 Kato Rd
<input checked="" type="checkbox"/> Chamber A (ISED:2324B-1)	<input type="checkbox"/> Chamber D (ISED:22541-1)	<input type="checkbox"/> Chamber I (ISED:2324A-5)
<input type="checkbox"/> Chamber B (ISED:2324B-2)	<input type="checkbox"/> Chamber E (ISED:22541-2)	<input type="checkbox"/> Chamber J (ISED:2324A-6)
<input type="checkbox"/> Chamber C (ISED:2324B-3)	<input type="checkbox"/> Chamber F (ISED:22541-3)	<input type="checkbox"/> Chamber K (ISED:2324A-1)
	<input type="checkbox"/> Chamber G (ISED:22541-4)	<input type="checkbox"/> Chamber L (ISED:2324A-3)
	<input type="checkbox"/> Chamber H (ISED:22541-5)	

The above test sites and facilities are covered under FCC Test Firm Registration # 208313. Chambers above are covered under Industry Canada company address and respective code

UL Verification Services Inc. is accredited by NVLAP, Laboratory Code 200065-0.

END OF TEST REPORT