



# TEST REPORT

**Report Number. :** 12422341-E1V2

**Applicant :** DATECS Ltd.  
DEPARTMENT OF INNOVATIVE TECHNOLOGIES  
4 "Datecs" Str.  
1592 SOFIA, BULGARIA

**Model :** INFINEA TAB M

**FCC ID :** YRWITMC

**EUT Description :** Payment Terminal with an integrated smart, magnetic stripe, and contactless card reader with Bluetooth connectivity and barcode reader.

**Test Standard(s) :** FCC 47 CFR PART 15 SUBPART C

**Date Of Issue:**

October 07, 2019

**Prepared by:**

UL Verification Services Inc.  
47173 Benicia Street  
Fremont, CA 94538, U.S.A.  
TEL: (510) 771-1000  
FAX: (510) 661-0888



Revision History

<u>Rev.</u>	<u>Issue Date</u>	<u>Revisions</u>	<u>Revised By</u>
V1	1/24/2019	Initial Issue	
V2	10/7/2019	Report revised based on reviewer's comments.	

## TABLE OF CONTENTS

<b>1. ATTESTATION OF TEST RESULTS .....</b>	<b>4</b>
<b>2. TEST METHODOLOGY .....</b>	<b>6</b>
<b>3. FACILITIES AND ACCREDITATION .....</b>	<b>6</b>
<b>4. CALIBRATION AND UNCERTAINTY .....</b>	<b>6</b>
4.1. MEASURING INSTRUMENT CALIBRATION .....	6
4.2. SAMPLE CALCULATION .....	6
4.3. MEASUREMENT UNCERTAINTY.....	7
<b>5. EQUIPMENT UNDER TEST .....</b>	<b>8</b>
5.1. DESCRIPTION OF EUT .....	8
5.2. MAXIMUM OUTPUT POWER.....	8
5.3. DESCRIPTION OF AVAILABLE ANTENNAS .....	8
5.4. SOFTWARE AND FIRMWARE.....	8
5.5. WORST-CASE CONFIGURATION AND MODE.....	8
5.6. DESCRIPTION OF TEST SETUP.....	9
<b>6. TEST AND MEASUREMENT EQUIPMENT .....</b>	<b>12</b>
<b>7. OCCUPIED BANDWIDTH .....</b>	<b>13</b>
7.1. 20 dB BANDWIDTH.....	13
<b>8. RADIATED EMISSION TEST RESULTS.....</b>	<b>15</b>
8.1. LIMITS AND PROCEDURE .....	15
8.2. FUNDAMENTAL AND SPURIOUS EMISSIONS (0.09 - 30 MHz) .....	17
8.2.1. FUNDAMENTAL – Without iPhone .....	17
8.2.2. FUNDAMENTAL – With iPhone .....	18
8.2.3. SPURIOUS EMISSION (0.09 - 30 MHz) – Without iPhone .....	19
8.2.4. SPURIOUS EMISSION (0.09 - 30 MHz) – With iPhone .....	20
8.3. TX SPURIOUS EMISSION 30 TO 1000 MHz .....	21
8.3.1. Without iPhone .....	21
8.3.2. With iPhone .....	23
<b>9. FREQUENCY STABILITY .....</b>	<b>25</b>
<b>10. AC MAINS LINE CONDUCTED EMISSIONS .....</b>	<b>26</b>
10.1. NORMAL OPERATION WITH ANTENNA .....	27
10.1.1. NORMAL OPERATION WITH ANTENNA PORT TERMINATED .....	29
<b>11. SETUP PHOTOS .....</b>	<b>31</b>

# 1. ATTESTATION OF TEST RESULTS

**COMPANY NAME:** DATECS Ltd.

**EUT DESCRIPTION:** Payment Terminal with an integrated smart, magnetic stripe, and contactless card reader with Bluetooth connectivity and barcode reader.

This device is designed to operate with an Apple iPad, iPad mini, iPod and iPhone.

**MODEL:** INFINEA TAB M

**SERIAL NUMBER:** 1819900010, 1819900011

**DATE TESTED:** September 30, 2019 – January 16, 2019; October 3, 2019

APPLICABLE STANDARDS	
STANDARD	TEST RESULTS
FCC PART 15 SUBPART C	Complies

UL Verification Services Inc. tested the above equipment in accordance with the requirements set forth in the above standards. All indications of Pass/Fail in this report are opinions expressed by UL Verification Services Inc. based on interpretations and/or observations of test results. Measurement Uncertainties were not taken into account and are published for informational purposes only. The test results show that the equipment tested is capable of demonstrating compliance with the requirements as documented in this report.

**Note:** The results documented in this report apply only to the tested sample, under the conditions and modes of operation as described herein. This document may not be altered or revised in any way unless done so by UL Verification Services Inc. and all revisions are duly noted in the revisions section. Any alteration of this document not carried out by UL Verification Services Inc. will constitute fraud and shall nullify the document. This report must not be used by the client to claim product certification, approval, or endorsement by NVLAP, NIST, any agency of the Federal Government, or any agency of any government.

Reviewed By:



---

Bobby Bayani  
Lead Project Engineer  
UL Verification Service Inc.

Prepared By:

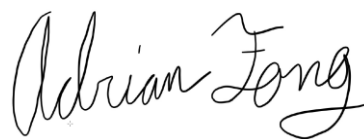

---

Adrian Fong  
Laboratory Engineer  
UL Verification Services Inc.

Approved & Released For  
UL Verification Services Inc By:



---

Dan Corona  
Operations Leader  
UL Verification Service Inc.

## 2. TEST METHODOLOGY

The tests documented in this report were performed in accordance with ANSI C63.10-2013, FCC CFR 47 Part 2, FCC CFR 47 Part 15.

## 3. FACILITIES AND ACCREDITATION

The test sites and measurement facilities used to collect data are located at 47173 and 47266 Benicia Street, and at 47658 Kato Road, Fremont, California, USA. Line conducted emissions are measured only at the 47173 address. The following table identifies which facilities were utilized for radiated emission measurements documented in this report. Specific facilities are also identified in the test results sections.

47173 Benicia Street	47266 Benicia Street	47658 Kato Rd.
<input checked="" type="checkbox"/> Chamber A	<input type="checkbox"/> Chamber D	<input checked="" type="checkbox"/> Chamber I
<input type="checkbox"/> Chamber B	<input type="checkbox"/> Chamber E	<input type="checkbox"/> Chamber J
<input type="checkbox"/> Chamber C	<input type="checkbox"/> Chamber F	<input checked="" type="checkbox"/> Chamber K
	<input type="checkbox"/> Chamber G	<input type="checkbox"/> Chamber L
	<input type="checkbox"/> Chamber H	

The above test sites and facilities are covered under FCC Test Firm Registration # 208313. Chambers above are covered under Industry Canada company address and respective code.

UL Verification Services Inc. is accredited by NVLAP, Laboratory Code 200065-0

## 4. CALIBRATION AND UNCERTAINTY

### 4.1. MEASURING INSTRUMENT CALIBRATION

The measuring equipment utilized to perform the tests documented in this report has been calibrated in accordance with the manufacturer's recommendations, and is traceable to recognized national standards.

### 4.2. SAMPLE CALCULATION

Where relevant, the following sample calculation is provided:

$$\begin{aligned} \text{Field Strength (dBuV/m)} &= \text{Measured Voltage (dBuV)} + \text{Antenna Factor (dB/m)} + \\ &\text{Cable Loss (dB)} - \text{Preamp Gain (dB)} \\ 36.5 \text{ dBuV} + 18.7 \text{ dB/m} + 0.6 \text{ dB} - 26.9 \text{ dB} &= 28.9 \text{ dBuV/m} \end{aligned}$$

### 4.3. MEASUREMENT UNCERTAINTY

Where relevant, the following measurement uncertainty levels have been estimated for tests performed on the apparatus:

PARAMETER	UNCERTAINTY
Worst Case Conducted Disturbance, 9KHz to 0.15 MHz	3.84 dB
Worst Case Conducted Disturbance, 0.15 to 30 MHz	3.65 dB
Worst Case Radiated Disturbance, 9KHz to 30 MHz	3.15 dB
Worst Case Radiated Disturbance, 30 to 1000 MHz	5.36 dB
Worst Case Radiated Disturbance, 1000 to 18000 MHz	4.32 dB
Worst Case Radiated Disturbance, 18000 to 26000 MHz	4.45 dB
Worst Case Radiated Disturbance, 26000 to 40000 MHz	5.24 dB

Uncertainty figures are valid to a confidence level of 95%.

## **5. EQUIPMENT UNDER TEST**

### **5.1. DESCRIPTION OF EUT**

Payment Terminal with an integrated smart, magnetic stripe, and contactless card reader with Bluetooth connectivity and barcode reader.

### **5.2. MAXIMUM OUTPUT POWER**

The testing was performed at 3 meter. The transmitter maximum E-field at 30 meter distance is 20.13dBuV/m which is converted from the 3 meter data.

### **5.3. DESCRIPTION OF AVAILABLE ANTENNAS**

The radio utilizes a flexible printed circuit board antenna.

### **5.4. SOFTWARE AND FIRMWARE**

The test utility software used during testing was IRETest2.0.3.

### **5.5. WORST-CASE CONFIGURATION AND MODE**

Radiated emission was performed with the EUT set to transmit at the channel with highest output power as worst-case scenario.

The fundamental of the EUT was investigated under three orthogonal orientations X (Flatbed), Y (Landscape), and Z (Portrait). The Y (Landscape) orientation was determined to be the worst-case orientation.

Although these tests were performed other than open area test site, adequate comparison measurements were confirmed against 30 m open are test site. Therefore sufficient tests were made to demonstrate that the alternative site produces results that correlate with the ones of tests made in an open field based on KDB 414788.



## 5.6. DESCRIPTION OF TEST SETUP

### SUPPORT EQUIPMENT

Description	Manufacturer	Model	Serial Number	FCC ID
AC Adapter	Apple	A1265	1X116KK248QZ	N/A
iPhone 8	Apple	A1778	C7CS5050HL4Q	BCG-E3091A

### I/O CABLES

I/O Cable List						
Cable No	Port	# of identical ports	Connector Type	Cable Type	Cable Length (m)	Remarks
1	USB	1	USB	Unshielded	1	EUT to AC/DC Charger

### TEST SETUP

The EUT is stand alone. Test software exercised the radio card.

**SETUP DIAGRAM**

**Without iPhone**

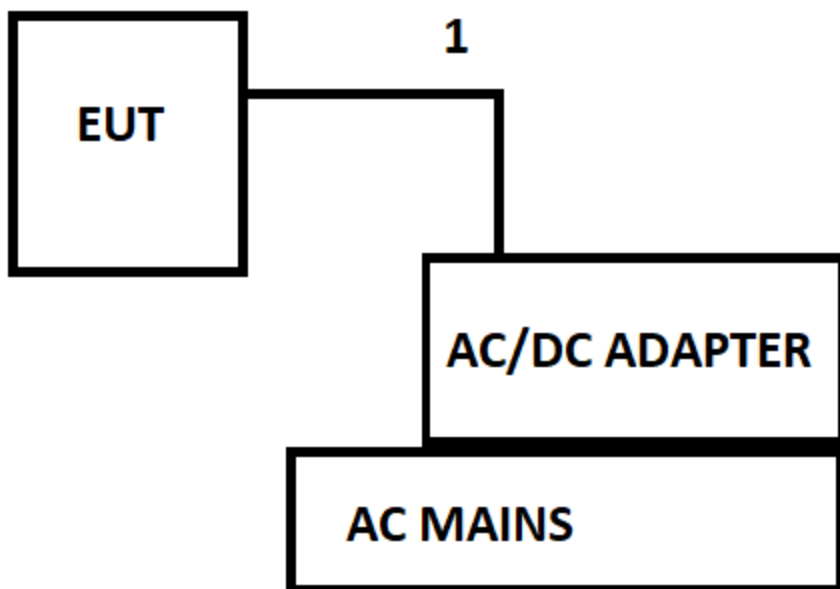

**With iPhone**

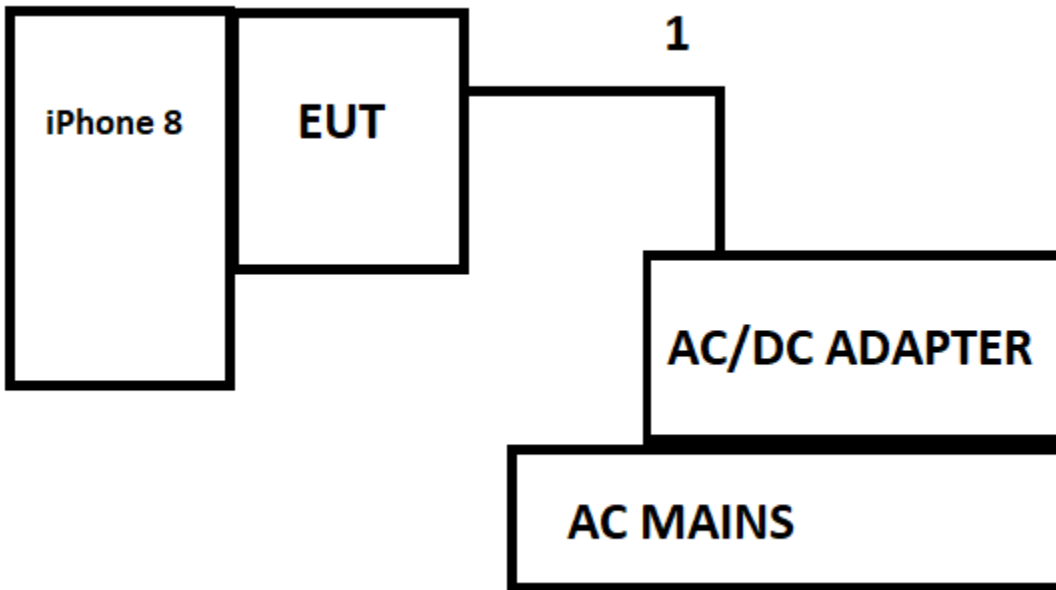

## 6. TEST AND MEASUREMENT EQUIPMENT

The following test and measurement equipment was utilized for the tests documented in this report:

Test Dates: 9/27/18 – 1/16/19

TEST EQUIPMENT LIST					
Description	Manufacturer	Model	ID Num	Cal Due	Last Cal
Amplifier, 100KHz to 1GHz, 32dB	Agilent (Keysight) Technologies	8447D	T15	10/16/2019	10/16/2018
Antenna, Broadband Hybrid, 30MHz to 2000MHz	Sunol Sciences Corp.	JB1	T130	10/16/2019	10/16/2018
Semianechoic Chamber A	TDK RF SOLUTIONS INC.	N/A	T1199	6/12/2019	6/12/2018
Spectrum Analyzer	Agilent (Keysight) Technologies	N9030A	T818	06/12/2019	06/12/2018
Spectrum Analyzer, PXA, 3Hz to 44GHz	Agilent (Keysight) Technologies	N9030A	T1466	04/16/2019	04/16/2018
Thermometer - Digital	Control Company	14-650-118	PRE0177861	02/26/2019	02/26/2018
Antenna, Active Loop 9 kHz - 30 MHz	Com-Power Corp.	AL-130R	T1868	12/13/2019	12/13/2018

UL SOFTWARE			
Radiated Software	UL	UL EMC	Ver 9.5, Dec 01, 2016

Test Date: 10/3/19

TEST EQUIPMENT LIST					
Description	Manufacturer	Model	ID Num	Cal Due	Last Cal
Amplifier, 100KHz to 1GHz, 32dB	HEWLET PACKARD	8447D	T64	6/25/2020	6/25/2019
Hybrid Antenna, 30MHz to 3GHz	SunAR rf motion	JB3	PRE0181574	8/1/2020	8/1/2019
Semianechoic Chamber K	TDK RF SOLUTIONS INC.	N/A	170329	5/26/2020	5/26/2019
EMI TEST RECEIVER	Rohde & Schwarz	ESW	PRE0179377	5/3/2020	5/3/2019
Antenna, Passive Loop 100 kHz - 30 MHz	Electro-Metrics	EM-6872	PRE0179467	5/31/2020	5/31/2019
Antenna, Passive Loop 30 Hz - 1 MHz	Electro-Metrics	EM-6871	PRE0179465	5/31/2020	5/31/2019
Antenna, Broadband Hybrid, 30MHz to 2000MHz	Sunol Sciences Corp.	JB3	T900	6/18/2020	6/18/2019
Amplifier, 9KHz to 1GHz, 32dB	SONOMA INSTRUMENT	310	170648	7/9/2020	7/9/2019
EMI TEST RECEIVER	Rohde & Schwarz	ESW	PRE0179376	2/14/2020	2/14/2019

UL SOFTWARE			
Radiated Software	UL	UL EMC	Ver 9.5, Sept 7, 2019

## 7. OCCUPIED BANDWIDTH

### 7.1. 20 dB BANDWIDTH

#### LIMITS

None; for reporting purposes only.

#### TEST PROCEDURE

The transmitter output is connected to the spectrum analyzer. The RBW is set to 10kHz. The VBW is set to 3 times the RBW. The sweep time is coupled. The spectrum analyzer internal 99% bandwidth function is utilized.

**Note:** Because the measured signal is CW-like, adjusting the RBW per C63.10 would not be practical since measured bandwidth will always follow the RBW and the result will be approximately twice the RBW.

**RESULTS**

Frequency (MHz)	20dB Bandwidth (KHz)
13.56	21.30

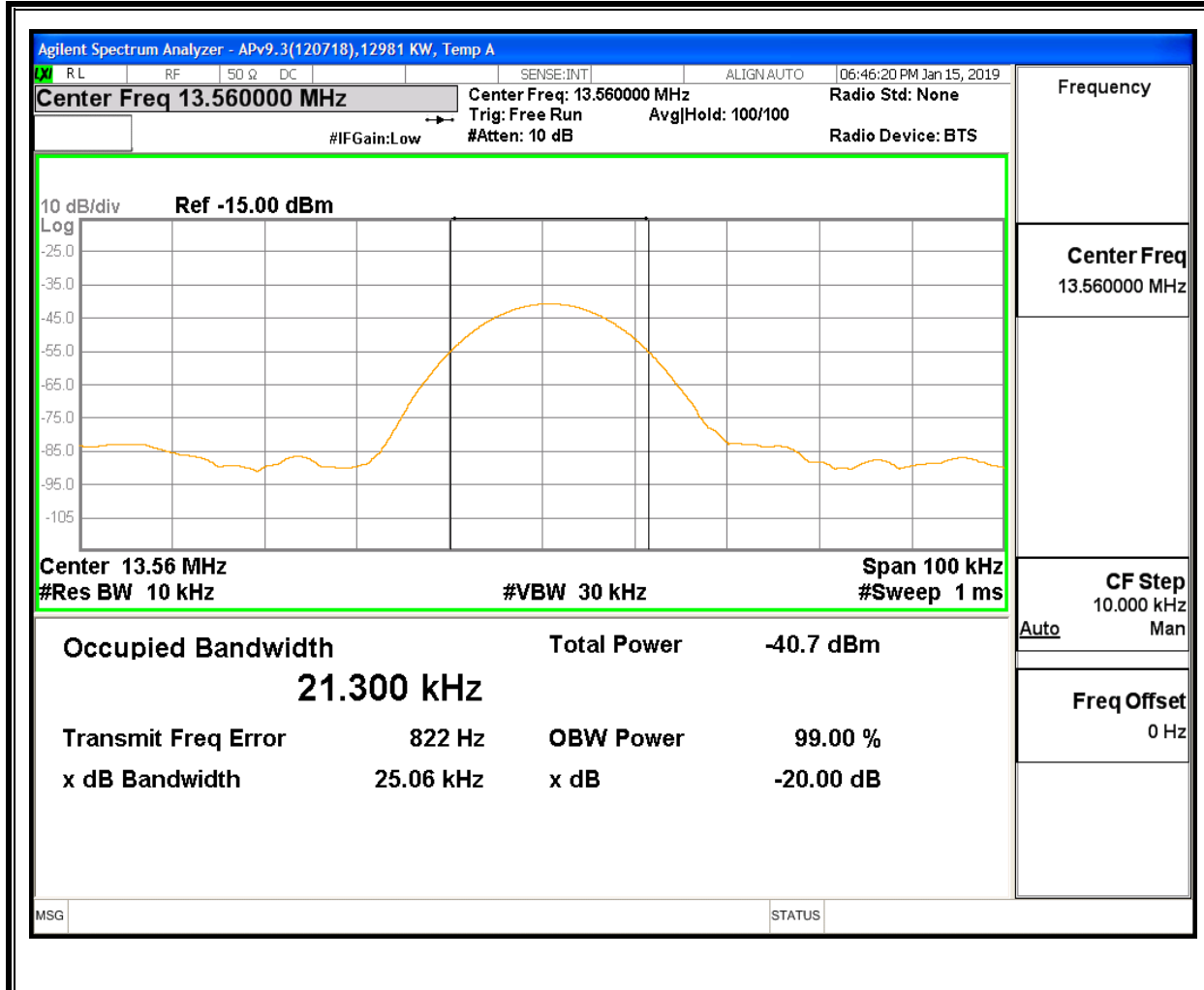

## 8. RADIATED EMISSION TEST RESULTS

### 8.1. LIMITS AND PROCEDURE

#### LIMIT

§15.225

(a) The field strength of any emissions within the band 13.553–13.567 MHz shall not exceed 15,848 microvolts/ meter at 30 meters.

(b) Within the bands 13.410–13.553 MHz and 13.567–13.710 MHz, the field strength of any emissions shall not exceed 334 microvolts/meter at 30 meters.

(c) Within the bands 13.110–13.410 MHz and 13.710–14.010 MHz the field strength of any emissions shall not exceed 106 microvolts/meter at 30 meters.

(d) The field strength of any emissions appearing outside of the 13.110– 14.010 MHz and shall not exceed the general radiated emission limits in § 15.209 as follows:

§15.209 (a) Except as provided elsewhere in this subpart, the emissions from an intentional radiator shall not exceed the field strength levels specified in the following table:

Limits for radiated disturbance of an intentional radiator		
Frequency range (MHz)	Limits (µV/m)	Measurement Distance (m)
0.009 – 0.490	2400 / F (kHz)	300
0.490 – 1.705	24000 / F (kHz)	30
1.705 – 30.0	30	30
30 – 88	100**	3
88 - 216	150**	3
216 – 960	200**	3
Above 960	500	3

\*\* Except as provided in paragraph (g), fundamental emissions from intentional radiators operating under this section shall not be located in the frequency bands 54-72 MHz, 76-88 MHz, 174-216 MHz or 470-806 MHz. However, operation within these frequency bands is permitted under other sections of this part, e.g. §§ 15.231 and 15.241.

§15.209 (b) In the emission table above, the tighter limit applies at the band edges.

Formula for converting the filed strength from uV/m to dBuV/m is:

Limit (dBuV/m) = 20 log limit (uV/m)

In addition:

§15.209 (d) The emission limits shown the above table are based on measurements employing a CISPR quasi-peak detector except for the frequency bands 9-90 kHz, 110-490 kHz and above 1000 MHz. Radiated emissions limits in these three bands are based on measurements employing an average detector.

§15.209 (d) The provisions in §§ 15.225, measuring emissions at distances other than the distances specified in the above table, determining the frequency range over which radiated emissions are to be measured, and limiting peak emissions apply to all devices operated under this part.

### **TEST PROCEDURE**

ANSI C63.10, 2013

The EUT is an intentional radiator that incorporates a digital device, the highest fundamental frequency generated or used in the device is 13.56 MHz; therefore, the frequency range was investigated from 0.15 MHz to the 10<sup>th</sup> harmonic of the highest fundamental frequency, or 1000 MHz, whichever is greater.

### **KDB 414788 OFS and Chamber Correlation Justification**

Base on FCC 15.31 (f) (2): measurements may be performed at a distance closer than that specified in the regulations; however, an attempt should be made to avoid making measurements in the near field.

OFS and chamber correlation testing had been performed and chamber measured test result is the worst case test result.

### **RESULTS**



## 8.2. FUNDAMENTAL AND SPURIOUS EMISSIONS (0.09 - 30 MHz)

### 8.2.1. FUNDAMENTAL – Without iPhone

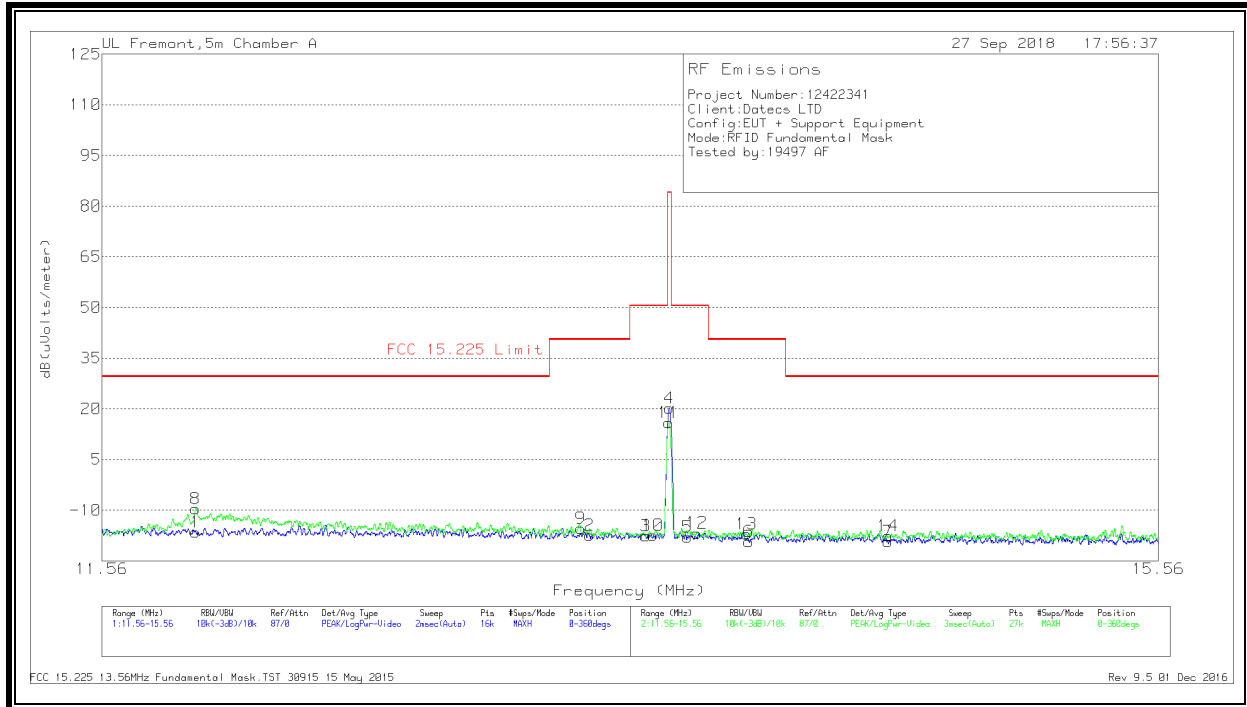

## DATA

### Trace Markers

Marker	Frequency (MHz)	Meter Reading (dBuV)	Det	Loop Antenna (dB/m)	Cbl (dB)	Dist Corr 30m	Corrected Reading dB(uVolts/meter)	FCC 15.225 Limit	PK Margin (dB)	Azimuth (Degs)
8	11.86902	19.17	Pk	10.8	.5	-40	-9.53	29.54	-39.07	0-360
1	11.86925	12.25	Pk	10.8	.5	-40	-16.45	29.54	-45.99	0-360
9	13.22589	13.3	Pk	10.7	.6	-40	-15.4	40.51	-55.91	0-360
2	13.25825	11.27	Pk	10.7	.6	-40	-17.43	40.51	-57.94	0-360
3	13.47075	11.16	Pk	10.7	.6	-40	-17.54	50.5	-68.04	0-360
10	13.49895	11.2	Pk	10.7	.6	-40	-17.5	50.5	-68	0-360
11	*13.55852	44.72	Pk	10.6	.6	-40	15.92	84	-68.08	0-360
4	*13.56013	48.93	Pk	10.6	.6	-40	20.13	84	-63.87	0-360
5	13.629	10.8	Pk	10.6	.6	-40	-18	50.5	-68.5	0-360
12	13.6656	12.03	Pk	10.6	.6	-40	-16.77	50.5	-67.27	0-360
13	13.8577	11.77	Pk	10.6	.5	-40	-17.13	40.51	-57.64	0-360
6	13.867	9.68	Pk	10.6	.5	-40	-19.22	40.51	-59.73	0-360
7	14.4195	9.61	Pk	10.6	.5	-40	-19.29	29.54	-48.83	0-360
14	14.42017	11.28	Pk	10.6	.5	-40	-17.62	29.54	-47.16	0-360

\* - Indicates fundamental frequency  
 Pk - Peak detector

### 8.2.2. FUNDAMENTAL – With iPhone



### DATA

#### Trace Markers

Marker	Frequency (MHz)	Meter Reading (dBuV)	Det	Loop Antenna (ACF)	Cables w/ PRE0186650	Dist Corr 30m (dB) 40Log	Corrected Reading dB(uVolts/meter)	FCC 15.225 Limit	PK Margin (dB)	Azimuth (Degs)
1	13.05761	35.54	Pk	34.2	-31.8	-40	-2.06	29.54	-31.6	0-360
2	13.33844	46.55	Pk	34.2	-31.8	-40	8.95	40.51	-31.56	0-360
3	13.51893	59.5	Pk	34.1	-31.8	-40	21.8	50.5	-28.7	0-360
4	13.558	74.77	Pk	34.1	-31.8	-40	37.07	84	-46.93	0-360
5	13.59885	55.53	Pk	34.1	-31.8	-40	17.83	50.5	-32.67	0-360
6	13.77068	47.45	Pk	34.1	-31.7	-40	9.85	40.51	-30.66	0-360
7	14.06238	34.23	Pk	34.1	-31.7	-40	-3.37	29.54	-32.91	0-360
8	12.999	36.17	Pk	34.2	-31.8	-40	-1.43	29.54	-30.97	0-360
9	13.3471	51.31	Pk	34.2	-31.8	-40	13.71	40.51	-26.8	0-360
10	13.52204	55.94	Pk	34.1	-31.8	-40	18.24	50.5	-32.26	0-360
11	13.558	74.78	Pk	34.1	-31.8	-40	37.08	84	-46.92	0-360
12	13.63859	56.21	Pk	34.1	-31.8	-40	18.51	50.5	-31.99	0-360
13	13.77112	48.5	Pk	34.1	-31.7	-40	10.9	40.51	-29.61	0-360
14	14.03574	39.77	Pk	34.1	-31.7	-40	2.17	29.54	-27.37	0-360

Pk - Peak detector

### 8.2.3. SPURIOUS EMISSION (0.09 - 30 MHz) – Without iPhone

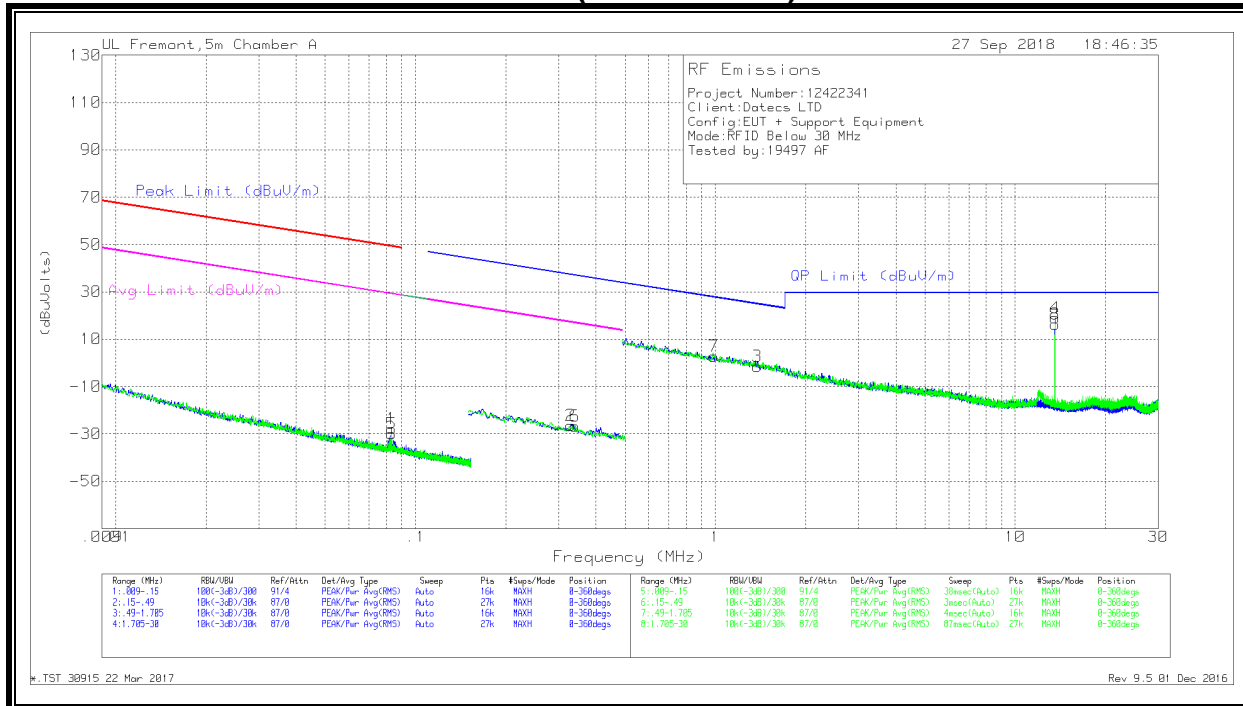

#### DATA

##### Trace Markers

Marker	Frequency (MHz)	Meter Reading (dBuV)	Det	Loop Antenna (dB/m)	Cbl (dB)	Dist Corr 300m	Corrected Reading (dBuVolts)	Peak Limit (dBuV/m)	Margin (dB)	Avg Limit (dBuV/m)	Margin (dB)	Azimuth (Degs)
5	.08307	38.66	Pk	11.4	.1	-80	-29.84	49.2	-79.04	29.2	-59.04	0-360
1	.0832	40.79	Pk	11.4	.1	-80	-27.71	49.18	-76.89	29.18	-56.89	0-360
2	.32846	42.51	Pk	10.9	.1	-80	-26.49	37.28	-63.77	17.28	-43.77	0-360
6	.34086	42.23	Pk	10.9	.1	-80	-26.77	36.96	-63.73	16.96	-43.73	0-360

##### Pk - Peak detector

Marker	Frequency (MHz)	Meter Reading (dBuV)	Det	Loop Antenna (dB/m)	Cbl (dB)	Dist Corr 30m	Corrected Reading (dBuVolts)	QP Limit (dBuV/m)	Margin (dB)	Azimuth (Degs)
7	.98837	31.35	Pk	11.3	.2	-40	2.85	27.72	-24.87	0-360
3	1.37764	27.05	Pk	11.3	.2	-40	-1.45	24.85	-26.3	0-360
4	*13.55998	47.33	Pk	11	.6	-40	18.93	29.5	-10.57	0-360
8	*13.55998	44.7	Pk	11	.6	-40	16.3	29.5	-13.2	0-360

\* - indicates fundamental frequency

Pk - Peak detector

### 8.2.4. SPURIOUS EMISSION (0.09 - 30 MHz) – With iPhone

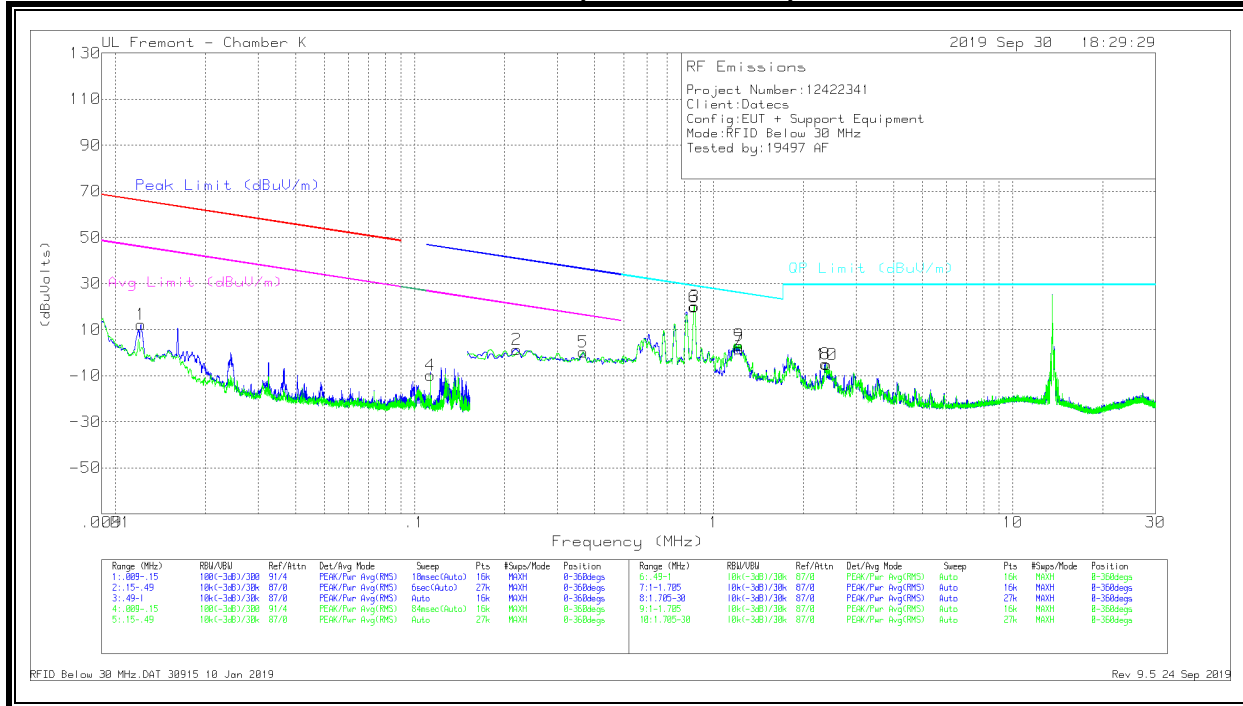

#### DATA

##### Trace Markers

Marker	Frequency (MHz)	Meter Reading (dBuV)	Det	Loop Antenna (dB/m)	Cbl (dB)	Dist Corr 300m	Corrected Reading (dBuVolts)	Peak Limit (dBuV/m)	Margin (dB)	Avg Limit (dBuV/m)	Margin (dB)	Azimuth (Degs)
1	.01217	24.16	Pk	59.9	-31.8	-40	12.26	65.88	-53.62	45.88	-33.62	65.88
2	.21962	17.3	Pk	56.1	-32.1	-40	1.3	40.78	-39.48	20.78	-19.48	0-360
4	.11309	6.88	Pk	55.5	-32.2	-40	-9.82	46.56	-56.38	26.56	-36.38	0-360
5	.36656	16.32	Pk	56	-32.1	-40	.22	36.33	-36.11	16.33	-16.11	0-360

##### Pk - Peak detector

Marker	Frequency (MHz)	Meter Reading (dBuV)	Det	Loop Antenna (dB/m)	Cbl (dB)	Dist Corr 30m	Corrected Reading (dBuVolts)	QP Limit (dBuV/m)	Margin (dB)	Azimuth (Degs)
7	.86186	36.24	Pk	56.1	-32.1	-40	20.24	28.91	-8.67	0-360
6	.86011	35.93	Pk	56.1	-32.1	-40	19.93	28.93	-9	0-360
7	1.21692	27.92	Pk	45.7	-32.1	-40	1.52	25.92	-24.4	0-360
8	2.3621	26.56	Pk	40.6	-32	-40	-4.84	29.5	-34.34	0-360
9	1.2163	29.51	Pk	45.7	-32.1	-40	3.11	25.93	-22.82	0-360
10	2.39144	26.29	Pk	40.5	-32	-40	-5.21	29.5	-34.71	0-360

##### Pk - Peak detector

### 8.3. TX SPURIOUS EMISSION 30 TO 1000 MHz

#### 8.3.1. Without iPhone

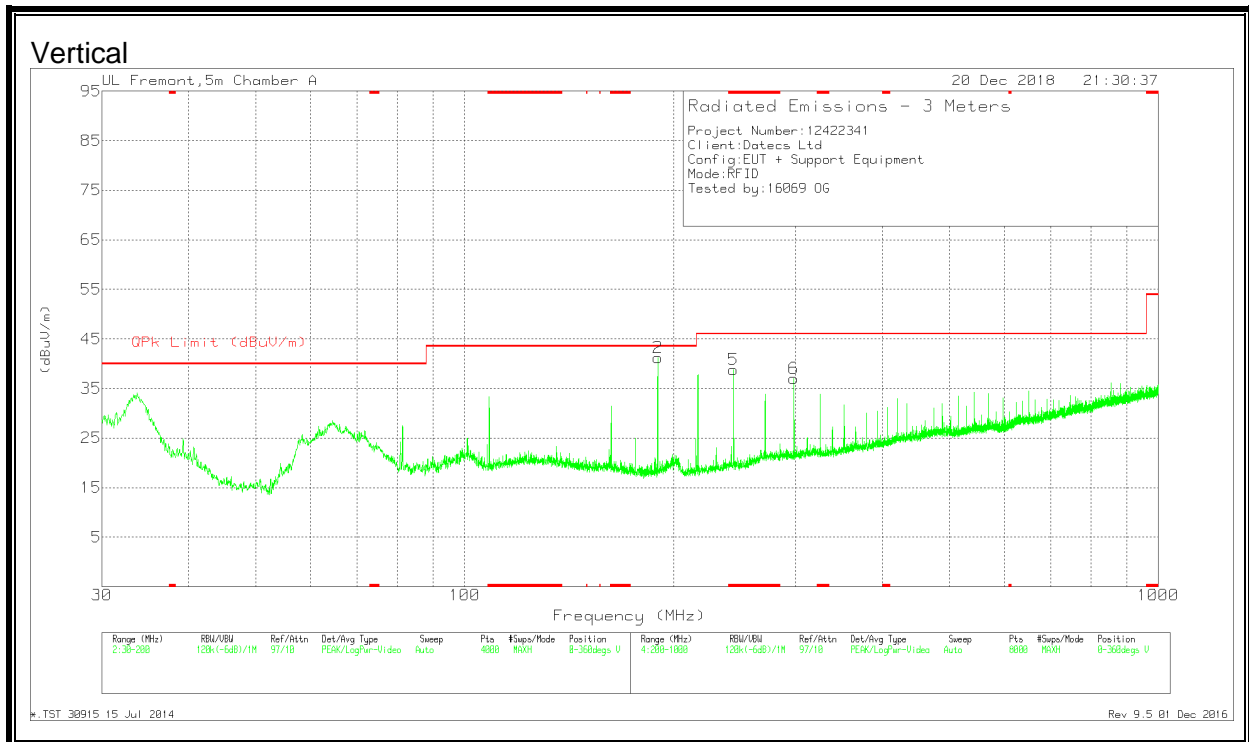
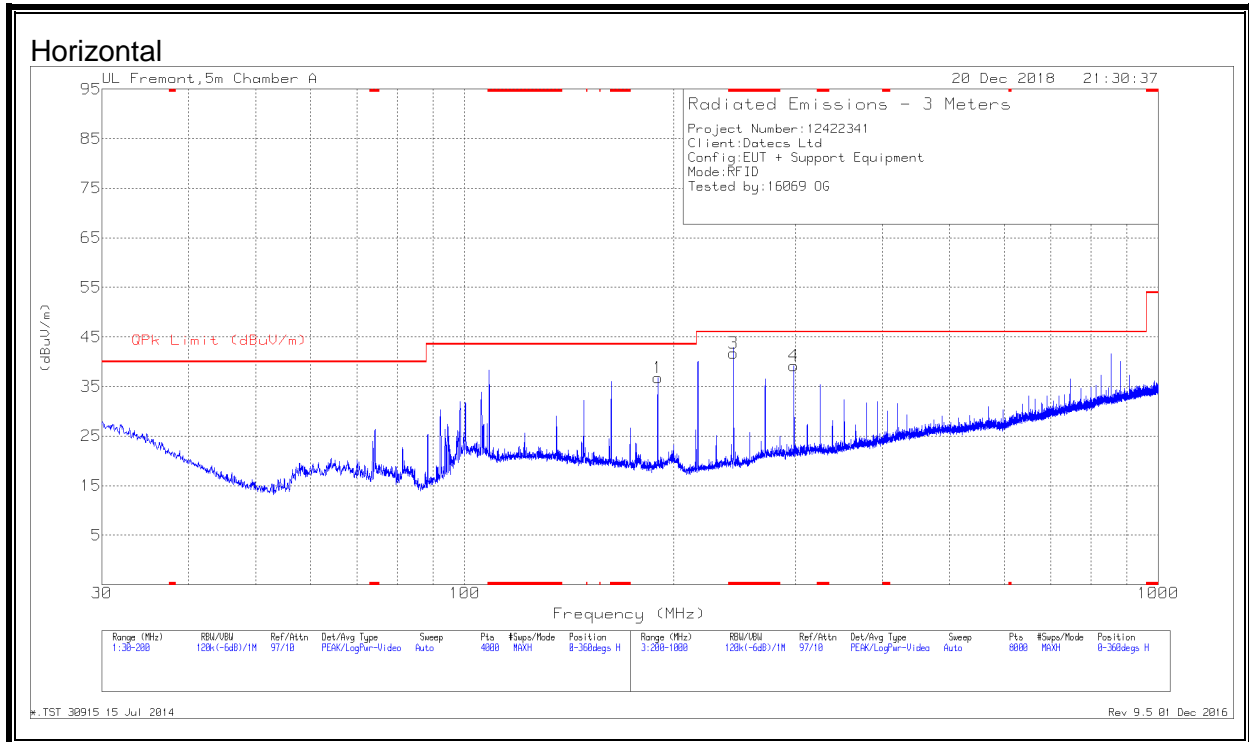

**DATA**

Marker	Frequency (MHz)	Meter Reading (dBuV)	Det	AF PRE0181574 (dB/m)	Amp/Cbl (dB/m)	Corrected Reading (dBuV/m)	QPk Limit (dBuV/m)	Margin (dB)	Azimuth (Degs)	Height (cm)	Polarity
3	* 244.0911	49.79	Pk	17.5	-24.7	42.59	46.02	-3.43	193	129	H
	* 244.0974	49.58	Qp	17.5	-24.7	42.38	46.02	-3.64	193	129	H
5	* 244.0937	46.04	Pk	17.5	-24.7	38.84	46.02	-7.18	310	266	V
	* 244.0875	45.67	Qp	17.5	-24.7	38.47	46.02	-7.55	310	266	V
1	189.8414	49.44	Pk	17.3	-25.2	41.54	43.52	-1.98	124	102	V
	189.8467	49.17	Qp	17.3	-25.2	41.27	43.52	-2.25	124	102	V
2	189.8438	45.52	Pk	17.3	-25.2	37.62	43.52	-5.9	194	101	H
	189.8443	44.86	Qp	17.3	-25.2	36.96	43.52	-6.56	194	101	H
4	298.3248	45.48	Pk	19.2	-24.4	40.28	46.02	-5.74	6	112	H
	298.3402	44.89	Qp	19.2	-24.4	39.69	46.02	-6.33	6	112	H
6	298.3296	42.74	Pk	19.2	-24.4	37.54	46.02	-8.48	5	149	V
	298.3387	41.84	Qp	19.2	-24.4	36.64	46.02	-9.38	5	149	V

\* - indicates frequency in CFR47 Pt 15 / IC RSS-Restricted Band

Pk - Peak detector

Qp - Quasi-Peak detector

### 8.3.2. With iPhone

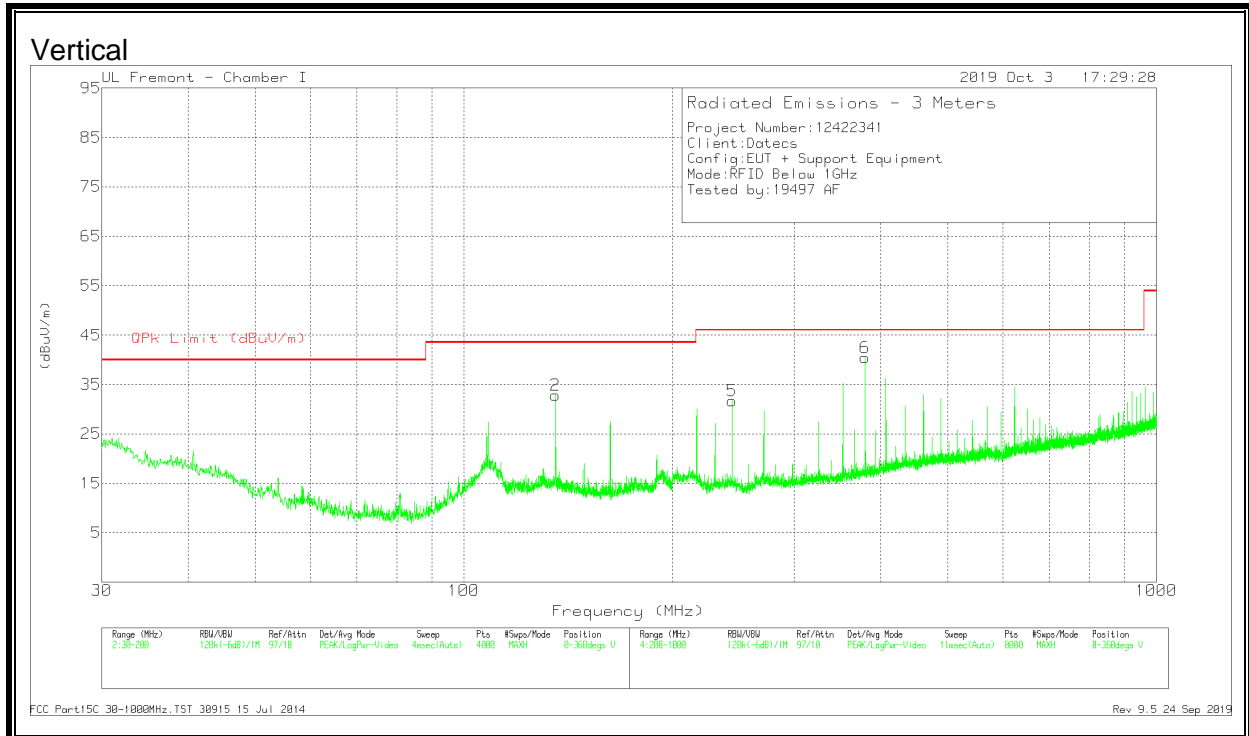
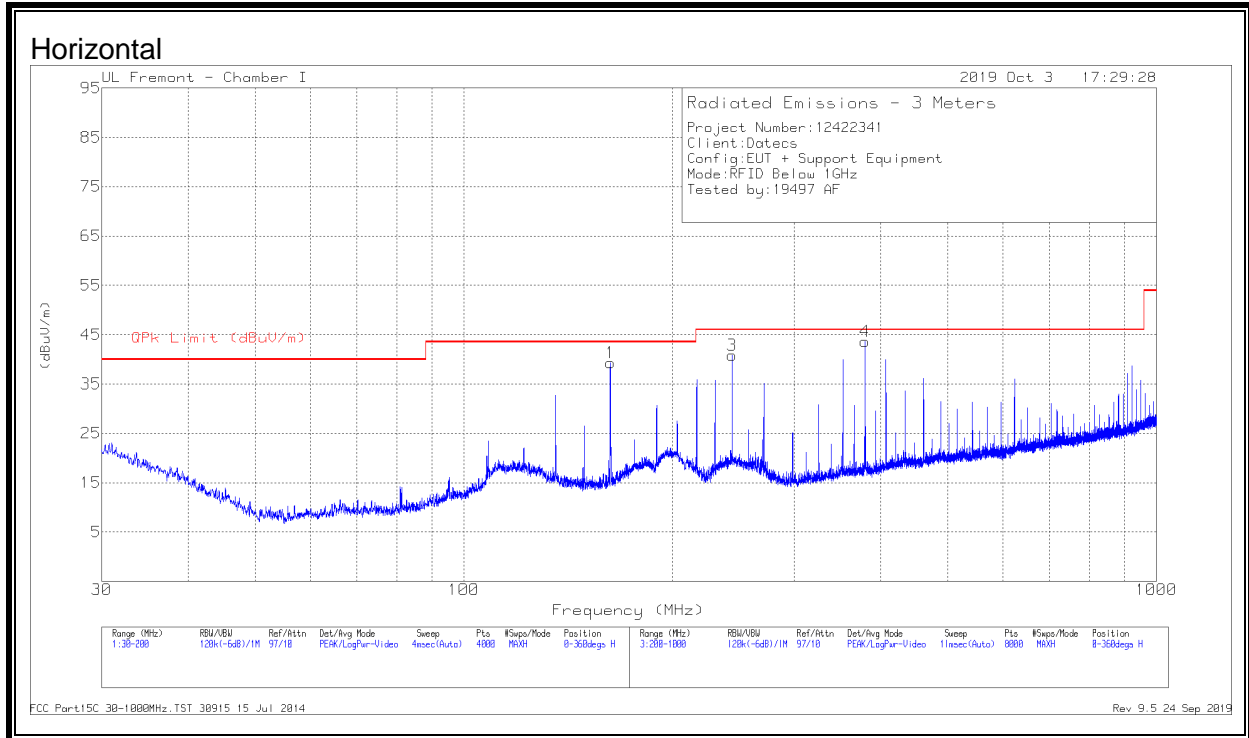

**DATA**

**Trace Markers**

Marker	Frequency (MHz)	Meter Reading (dBuV)	Det	AF PRE0184971 (dB/m)	Amp Cbl (dB)	Corrected Reading (dBuV/m)	QPk Limit (dBuV/m)	Margin (dB)	Azimuth (Degs)	Height (cm)	Polarity
1	162.7193	51.98	Pk	17.8	-30.5	39.28	43.52	-4.24	0-360	199	H
2	135.5973	44.34	Pk	19.1	-30.6	32.84	43.52	-10.68	0-360	102	V
3	244.0057	53.24	Pk	17.6	-30	40.84	46.02	-5.18	0-360	102	H
4	379.6233	52.38	Pk	20.9	-29.6	43.68	46.02	-2.34	0-360	102	H
5	244.0057	44.05	Pk	17.6	-30	31.65	46.02	-14.37	0-360	102	V
6	379.6233	49.15	Pk	20.9	-29.6	40.45	46.02	-5.57	0-360	199	V

Pk - Peak detector

**Radiated Emissions**

Frequency (MHz)	Meter Reading (dBuV)	Det	AF PRE0184971 (dB/m)	Amp Cbl (dB)	Corrected Reading (dBuV/m)	QPk Limit (dBuV/m)	Margin (dB)	Azimuth (Degs)	Height (cm)	Polarity
162.737	52.14	Pk	17.8	-30.5	39.44	43.52	-4.08	344	163	H
162.737	51.06	Qp	17.8	-30.5	38.36	43.52	-5.16	344	163	H
244.1203	54.91	Pk	17.6	-30	42.51	46.02	-3.51	319	121	H
244.1203	51.51	Qp	17.6	-30	39.11	46.02	-6.91	319	121	H
379.6885	53.5	Pk	20.9	-29.6	44.8	46.02	-1.22	182	101	H
379.6885	50.83	Qp	20.9	-29.6	42.13	46.02	-3.89	182	101	H
379.6981	50.87	Pk	20.9	-29.6	42.17	46.02	-3.85	129	153	V
379.6981	48.96	Qp	20.9	-29.6	40.26	46.02	-5.76	129	153	V

Pk - Peak detector

Qp - Quasi-Peak detector



## 9. FREQUENCY STABILITY

### LIMIT

§15.225 (e) The frequency tolerance of the carrier signal shall be maintained within  $\pm 0.01\%$  of the operating frequency, over a temperature variation of -20 degrees to +50 degrees C at normal supply voltage, and for a variation in the primary supply voltage from 85% to 115% of the rated supply voltage at a temperature of 20 degrees C. For battery operated equipment, the equipment tests shall be performed using a new battery.

### TEST PROCEDURE

ANSI C63.10-2013 Clause 6.8

### RESULTS

Tested By:	12981 KW
Date:	1/15/2019

No non-compliance noted.

Reference Frequency: EUT Channel 13.56 MHz @ 20°C										
Limit: $\pm 100$ ppm = 1.356 kHz										
Power Supply	Envir. Temp	Frequency Deviation Measured with Time Elapse								
(Vdc)	(°C)	Startup (MHz)	Delta (ppm)	@ 2 mins (MHz)	Delta (ppm)	@ 5 mins (MHz)	Delta (ppm)	@ 10 mins (MHz)	Delta (ppm)	Limit (ppm)
5.00	50	13.5604470	1.468	13.5604482	1.375	13.5604500	1.241	13.5604519	1.101	$\pm 100$
5.00	40	13.5604503	1.220	13.5604484	1.363	13.5604461	1.533	13.5604458	1.551	$\pm 100$
5.00	30	13.5604578	0.665	13.5604566	0.755	13.5604555	0.836	13.5604548	0.892	$\pm 100$
<b>5.00</b>	<b>20</b>	<b>13.5604669</b>	<b>0.000</b>	<b>13.5604666</b>	<b>0.015</b>	<b>13.5604664</b>	<b>0.036</b>	<b>13.5604660</b>	<b>0.062</b>	<b><math>\pm 100</math></b>
5.00	10	13.5604655	0.103	13.5604730	-0.454	13.5604756	-0.645	13.5604772	-0.763	$\pm 100$
5.00	0	13.5604795	-0.929	13.5604817	-1.092	13.5604850	-1.338	13.5604873	-1.505	$\pm 100$
5.00	-10	13.5604902	-1.724	13.5604940	-2.003	13.5604971	-2.229	13.5604992	-2.388	$\pm 100$
4.25	20	13.5604620	0.358	13.5604619	0.368	13.5604616	0.385	13.5604614	0.404	$\pm 100$
5.75	20	13.5604598	0.523	13.5604598	0.519	13.5604598	0.520	13.5604598	0.522	$\pm 100$

## 10. AC MAINS LINE CONDUCTED EMISSIONS

### LIMITS

§15.207

(a) Except as shown in paragraphs (b) and (c) of this section, for an intentional radiator that is designed to be connected to the public utility (AC) power line, the radio frequency voltage that is conducted back onto the AC power line on any frequency or frequencies, within the band 150 kHz to 30 MHz, shall not exceed the limits in the following table, as measured using a 50 $\mu$ H/50 ohms line impedance stabilization network (LISN). Compliance with the provisions of this paragraph shall be based on the measurement of the radio frequency voltage between each power line and ground at the power terminal. The lower limit applies at the band edges.

Frequency range (MHz)	Limits (dB $\mu$ V)	
	Quasi-peak	Average
0.15 to 0.50	66 to 56	56 to 46
0.50 to 5	56	46
5 to 30	60	50

Notes:  
1. The lower limit shall apply at the transition frequencies  
2. The limit decreases linearly with the logarithm of the frequency in the range 0.15 MHz to 0.50 MHz.

### TEST PROCEDURE

ANSI C63.10:2013

### RESULTS

No non-compliance noted:

## 10.1. NORMAL OPERATION WITH ANTENNA

### LINE 1 RESULTS

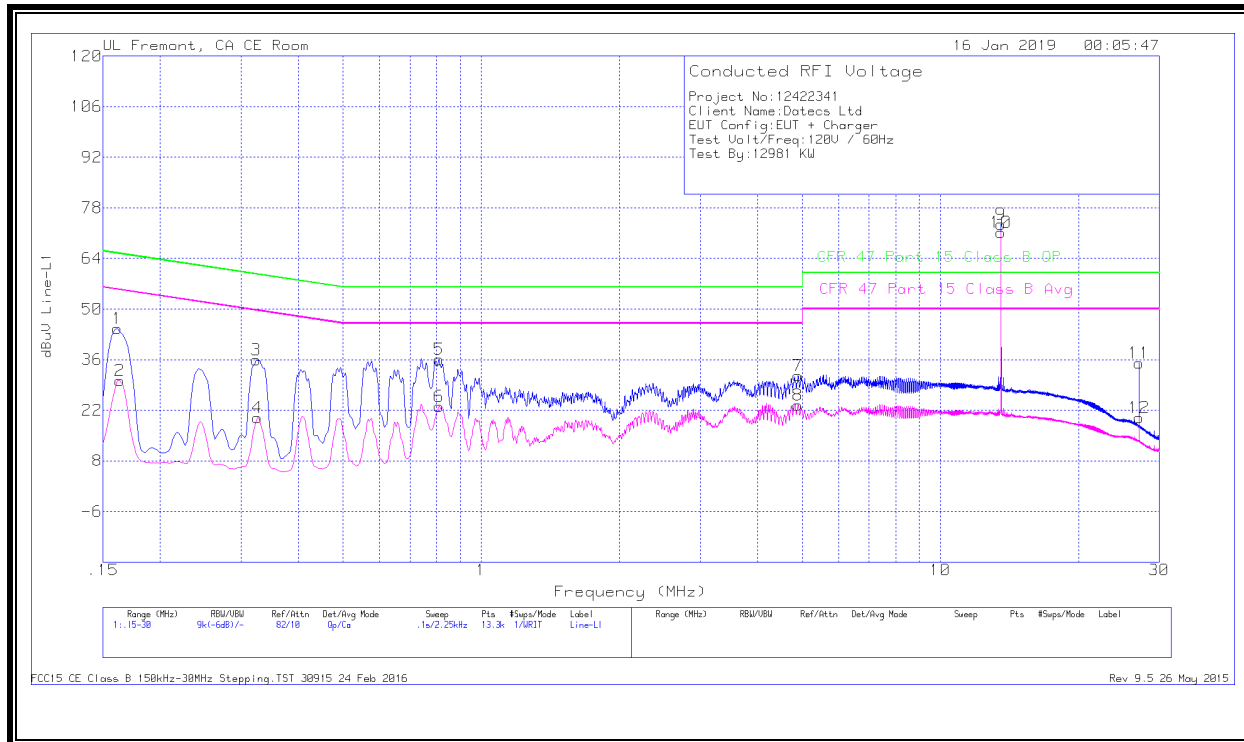

### WORST EMISSIONS

#### Trace Markers

Range 1: Line-L1 .15 - 30MHz											
Marker	Frequency (MHz)	Meter Reading (dBuV)	Det	LISN L1	LC Cables C1&C3	Limiter (dB)	Corrected Reading dBuV	CFR 47 Part 15 Class B QP	QP Margin (dB)	CFR 47 Part 15 Class B Avg	Av(CISPR) Margin (dB)
1	.16125	34.4	Qp	.1	0	10.1	44.6	65.4	-20.8	-	-
2	.1635	20.03	Ca	.1	0	10.1	30.23	-	-	55.28	-25.05
3	.32325	25.8	Qp	0	0	10.1	35.9	59.62	-23.72	-	-
4	.3255	9.88	Ca	0	0	10.1	19.98	-	-	49.57	-29.59
5	.80925	25.91	Qp	0	0	10.1	36.01	56	-19.99	-	-
6	.80925	13.02	Ca	0	0	10.1	23.12	-	-	46	-22.88
7	4.902	21.32	Qp	0	.1	10.1	31.52	56	-24.48	-	-
8	4.902	13.19	Ca	0	.1	10.1	23.39	-	-	46	-22.61
9	13.56	62.91	Qp	.1	.2	10.2	73.41	60	13.41	-	-
10	13.56	60.71	Ca	.1	.2	10.2	71.21	-	-	50	21.21
11	27.12075	24.08	Qp	.1	.4	10.5	35.08	60	-24.92	-	-
12	27.12075	8.94	Ca	.1	.4	10.5	19.94	-	-	50	-30.06

Qp - Quasi-Peak detector

Ca - CISPR average detection

Note: Markers 9 and 10 are the 13.56MHz NFC Fundamental

**LINE 2 RESULTS**

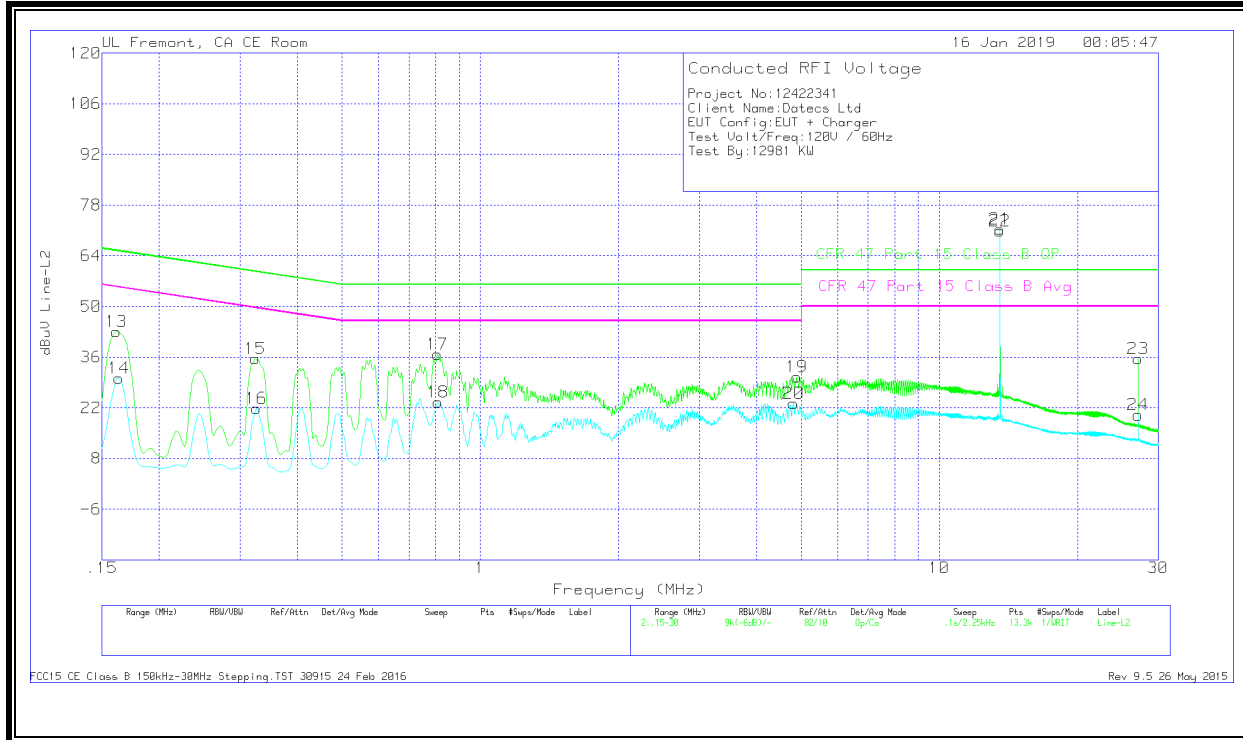

**WORST EMISSIONS**

Trace Markers

Range 2: Line-L2 .15 - 30MHz											
Marker	Frequency (MHz)	Meter Reading (dBuV)	Det	LISN L2	LC Cables C2&C3	Limiter (dB)	Corrected Reading dBuV	CFR 47 Part 15 Class B QP	QP Margin (dB)	CFR 47 Part 15 Class B Avg	Av(CISPR) Margin (dB)
13	.16125	32.8	Qp	.1	0	10.1	43	65.4	-22.4	-	-
14	.1635	20.05	Ca	.1	0	10.1	30.25	-	-	55.28	-25.03
15	.32325	25.44	Qp	0	0	10.1	35.54	59.62	-24.08	-	-
16	.3255	11.79	Ca	0	0	10.1	21.89	-	-	49.57	-27.68
17	.807	26.72	Qp	0	0	10.1	36.82	56	-19.18	-	-
18	.80925	13.4	Ca	0	0	10.1	23.5	-	-	46	-22.5
19	4.89525	20.31	Qp	0	.1	10.1	30.51	56	-25.49	-	-
20	4.812	12.96	Ca	0	.1	10.1	23.16	-	-	46	-22.84
21	13.56	60.93	Qp	.1	.2	10.2	71.43	60	11.43	-	-
22	13.56	60.32	Ca	.1	.2	10.2	70.82	-	-	50	20.82
23	27.12075	24.57	Qp	.1	.4	10.5	35.57	60	-24.43	-	-
24	27.12075	9.02	Ca	.1	.4	10.5	20.02	-	-	50	-29.98

Qp - Quasi-Peak detector

Ca - CISPR average detection

Note: Markers 21 and 22 are the 13.56MHz NFC Fundamental

### 10.1.1. NORMAL OPERATION WITH ANTENNA PORT TERMINATED

#### LINE 1 RESULTS

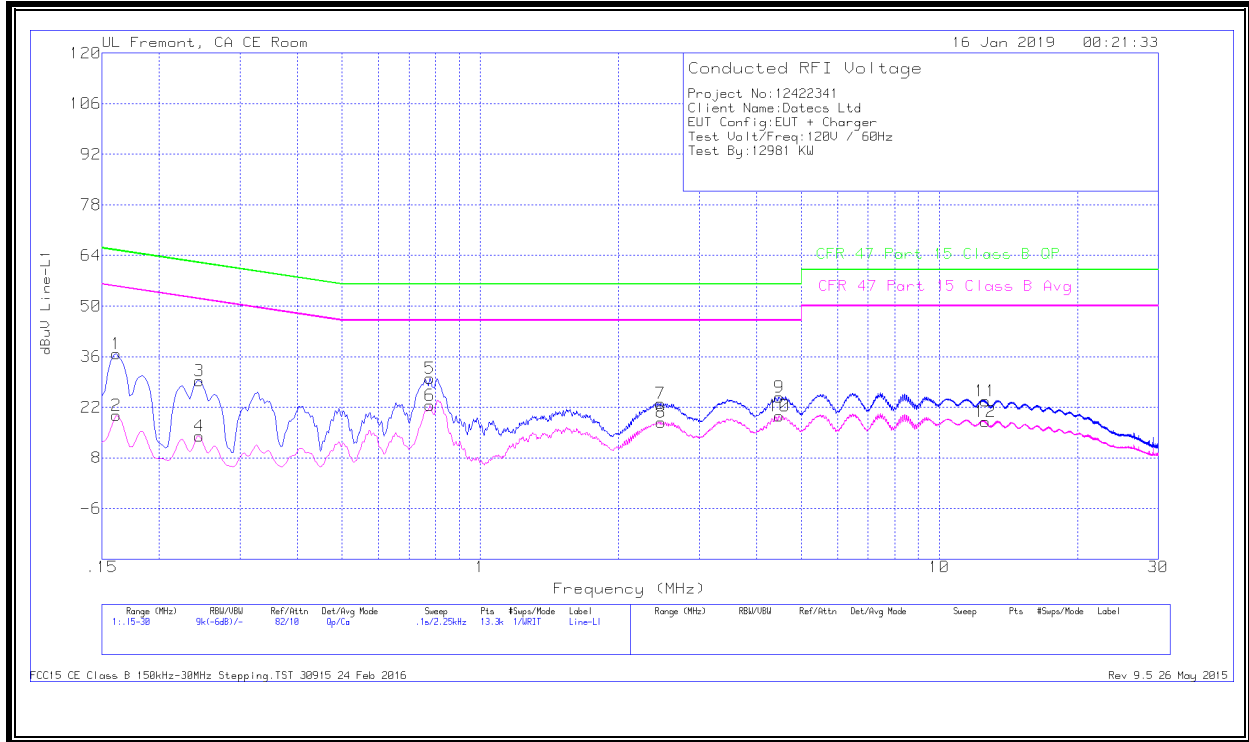

#### WORST EMISSIONS

##### Trace Markers

Range 1: Line-L1 .15 - 30MHz											
Marker	Frequency (MHz)	Meter Reading (dBuV)	Det	LISN L1	LC Cables C1&C3	Limiter (dB)	Corrected Reading dBuV	CFR 47 Part 15 Class B QP	QP Margin (dB)	CFR 47 Part 15 Class B Avg	Av(CISPR) Margin (dB)
1	.16125	26.58	Qp	.1	0	10.1	36.78	65.4	-28.62	-	-
2	.16125	9.58	Ca	.1	0	10.1	19.78	-	-	55.4	-35.62
3	.2445	19.21	Qp	0	0	10.1	29.31	61.94	-32.63	-	-
4	.2445	3.91	Ca	0	0	10.1	14.01	-	-	51.94	-37.93
5	.77775	19.89	Qp	0	0	10.1	29.99	56	-26.01	-	-
6	.77775	12.37	Ca	0	0	10.1	22.47	-	-	46	-23.53
7	2.472	12.88	Qp	0	.1	10.1	23.08	56	-32.92	-	-
8	2.4765	7.69	Ca	0	.1	10.1	17.89	-	-	46	-28.11
9	4.479	14.6	Qp	0	.1	10.1	24.8	56	-31.2	-	-
10	4.479	9.4	Ca	0	.1	10.1	19.6	-	-	46	-26.4
11	12.6105	13.29	Qp	.1	.2	10.2	23.79	60	-36.21	-	-
12	12.60938	7.49	Ca	.1	.2	10.2	17.99	-	-	50	-32.01

Qp - Quasi-Peak detector  
 Ca - CISPR average detection

**LINE 2 RESULTS**

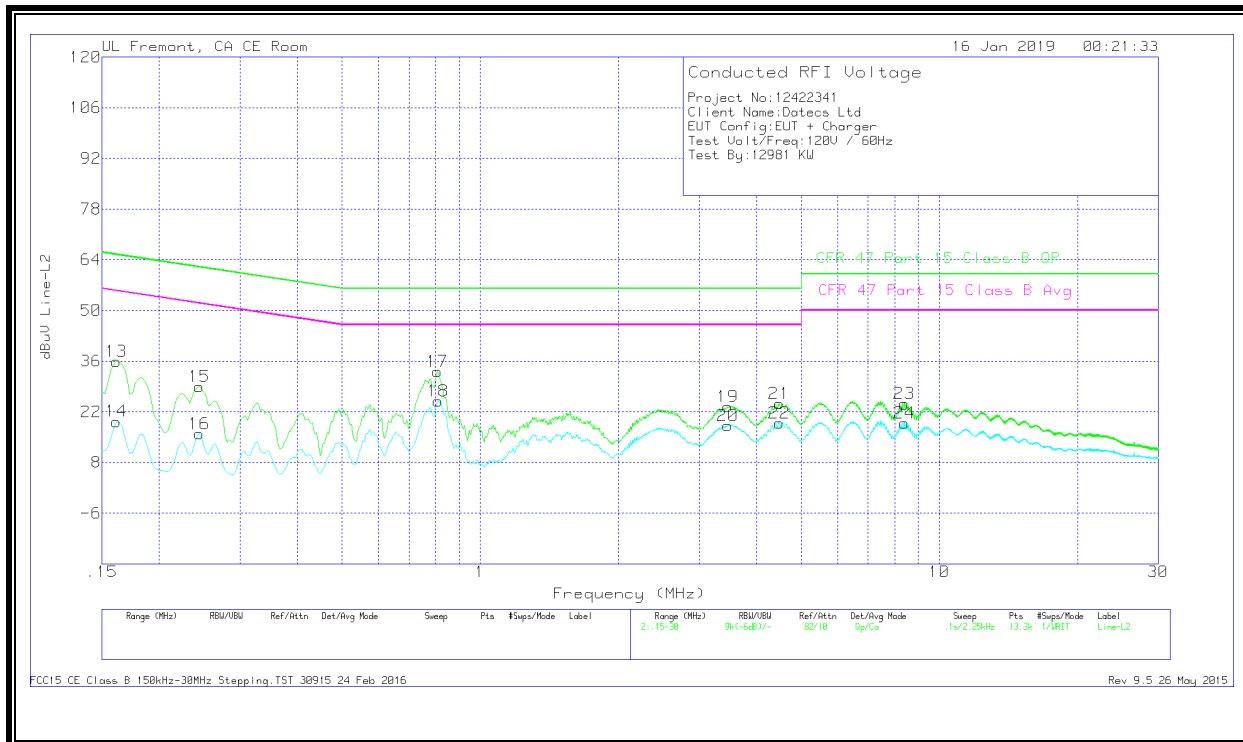

**WORST EMISSIONS**

**Trace Markers**

Range 2: Line-L2 .15 - 30MHz											
Marker	Frequency (MHz)	Meter Reading (dBuV)	Det	LISN L2	LC Cables C2&C3	Limiter (dB)	Corrected Reading dBuV	CFR 47 Part 15 Class B QP	QP Margin (dB)	CFR 47 Part 15 Class B Avg	Av(CISPR) Margin (dB)
13	.16125	25.76	Qp	.1	0	10.1	35.96	65.4	-29.44	-	-
14	.16125	9.12	Ca	.1	0	10.1	19.32	-	-	55.4	-36.08
15	.2445	18.81	Qp	0	0	10.1	28.91	61.94	-33.03	-	-
16	.2445	5.85	Ca	0	0	10.1	15.95	-	-	51.94	-35.99
17	.807	22.99	Qp	0	0	10.1	33.09	56	-22.91	-	-
18	.80925	14.81	Ca	0	0	10.1	24.91	-	-	46	-21.09
19	3.46088	13.25	Qp	0	.1	10.1	23.45	56	-32.55	-	-
20	3.4665	8.03	Ca	0	.1	10.1	18.23	-	-	46	-27.77
21	4.48575	14	Qp	0	.1	10.1	24.2	56	-31.8	-	-
22	4.48575	8.75	Ca	0	.1	10.1	18.95	-	-	46	-27.05
23	8.403	13.79	Qp	0	.2	10.2	24.19	60	-35.81	-	-
24	8.403	8.46	Ca	0	.2	10.2	18.86	-	-	50	-31.14

Qp - Quasi-Peak detector  
 Ca - CISPR average detection