

**12.2. System Check Plots – A1428 & A1429**

This appendix contains the following system validation distribution scans.

Scan Reference Number	Title
001	System Performance Check 750MHz Head 09 04 15
002	System Performance Check 750MHz Body 09 04 15
003	System Performance Check 900MHz Head 30 03 15
004	System Performance Check 900MHz Head 07 04 15
005	System Performance Check 900MHz Body 30 03 15
006	System Performance Check 900MHz Body 07 04 15
007	System Performance Check 1800MHz Head 13 04 15
008	System Performance Check 1800MHz Body 13 04 15
009	System Performance Check 1900MHz Head 14 04 15
010	System Performance Check 1900MHz Body 16 04 15
011	System Performance Check 2450MHz Head 14 04 15
012	System Performance Check 2450MHz Body 07 04 15
013	System Performance Check 2450MHz Body 29 04 15
014	System Performance Check 5250MHz Head 16 04 15
015	System Performance Check 5250MHz Body 13 04 15
016	System Performance Check 5600MHz Head 16 04 15
017	System Performance Check 5600MHz Body 13 04 15
018	System Performance Check 5750MHz Head 16 04 15
019	System Performance Check 5750MHz Body 13 04 15

001: System Performance Check 750MHz Head 09 04 15

Date: 09/04/2015

DUT: Dipole 750 MHz; Type: D750V3; Serial: D750V3 - SN:1011

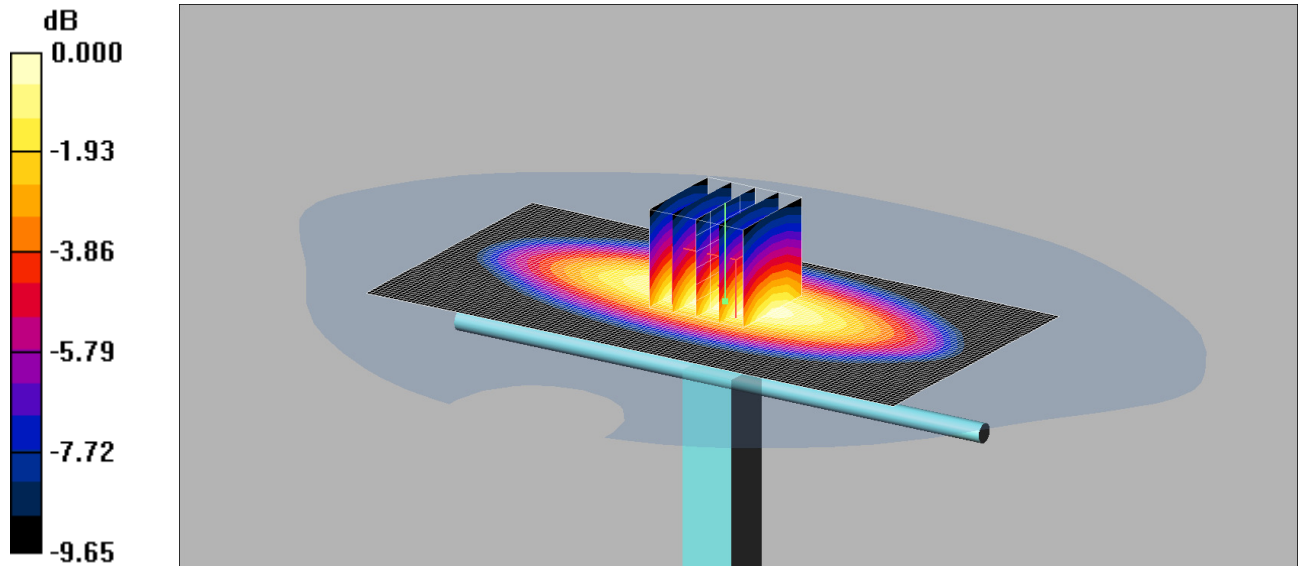

0 dB = 2.16mW/g

Communication System: CW; Frequency: 750 MHz; Duty Cycle: 1:1

Medium: 750 MHz HSL Medium parameters used:  $f = 750 \text{ MHz}$ ;  $\sigma = 0.849 \text{ mho/m}$ ;  $\epsilon_r = 42.4$ ;  $\rho = 1000 \text{ kg/m}^3$

Phantom section: Flat Section

DASY4 Configuration:

- Probe: ET3DV6 - SN1529; ConvF(6.6, 6.6, 6.6);
- Sensor-Surface: 4mm (Mechanical Surface Detection)
- Electronics: DAE3 Sn394; Calibrated: 16/05/2014
- Phantom: SAM 12b (Site 56); Type: SAM 4.0; Serial: TP:1192
- Measurement SW: DASY4, V4.6 Build 19; Postprocessing SW: SEMCAD, V1.8 Build 159

**d=15mm, Pin=250mW 2 2/Area Scan (61x121x1):** Measurement grid: dx=15mm, dy=15mm

Maximum value of SAR (interpolated) = 2.16 mW/g

**d=15mm, Pin=250mW 2 2/Zoom Scan (5x7x7) (5x5x7)/Cube 0:** Measurement grid: dx=8mm, dy=8mm, dz=5mm

Reference Value = 52.7 V/m; Power Drift = -0.013 dB

Peak SAR (extrapolated) = 2.83 W/kg

**SAR(1 g) = 2.01 mW/g; SAR(10 g) = 1.35 mW/g**

Maximum value of SAR (measured) = 2.16 mW/g

002: System Performance Check 750MHz Body 09 04 15

Date: 09/04/2015

DUT: Dipole 750 MHz; Type: D750V3; Serial: D750V3 - SN:1011

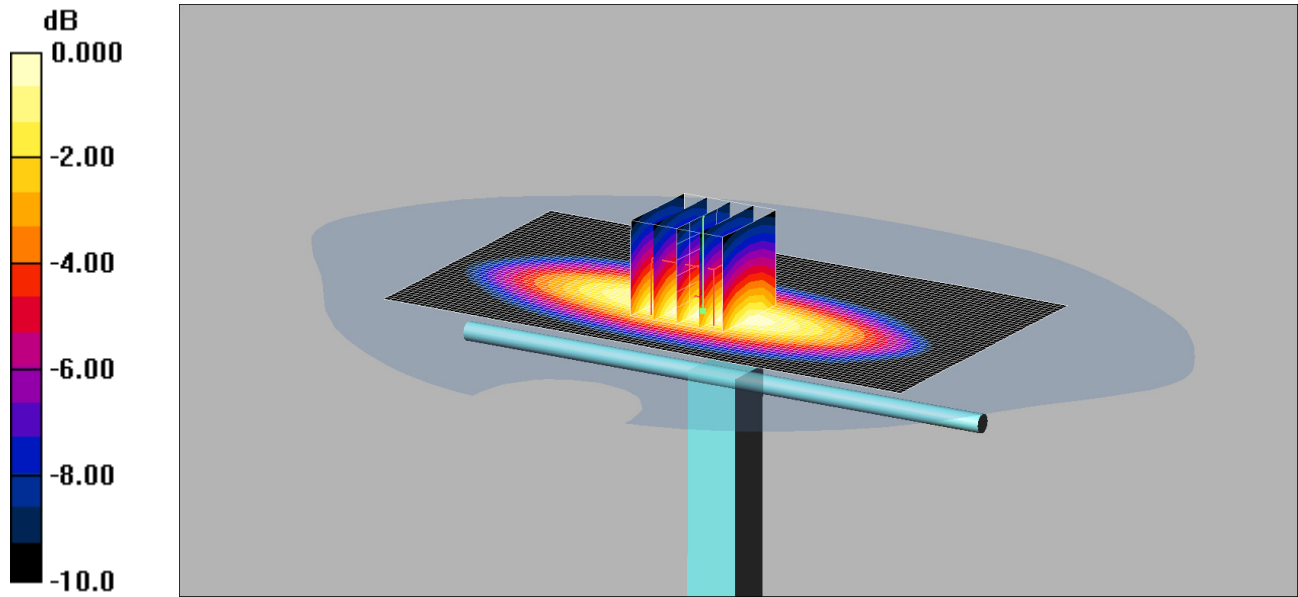

0 dB = 2.28mW/g

Communication System: CW; Frequency: 750 MHz; Duty Cycle: 1:1

Medium: 750/900 MHz MSL Medium parameters used:  $f = 750 \text{ MHz}$ ;  $\sigma = 0.964 \text{ mho/m}$ ;  $\epsilon_r = 54.1$ ;  $\rho = 1000 \text{ kg/m}^3$

Phantom section: Flat Section

DASY4 Configuration:

- Probe: ET3DV6 - SN1529; ConvF(6.15, 6.15, 6.15);
- Sensor-Surface: 4mm (Mechanical Surface Detection)
- Electronics: DAE3 Sn394; Calibrated: 16/05/2014
- Phantom: SAM 12a (Site 56); Type: SAM 4.0; Serial: TP:1020
- Measurement SW: DASY4, V4.6 Build 19; Postprocessing SW: SEMCAD, V1.8 Build 159

**d=15mm, Pin=250mW 2/Area Scan (51x91x1):** Measurement grid: dx=20mm, dy=20mm

Maximum value of SAR (interpolated) = 2.28 mW/g

**d=15mm, Pin=250mW 2/Zoom Scan (5x5x7) 2 (5x5x7)/Cube 0:** Measurement grid: dx=8mm, dy=8mm, dz=5mm

Reference Value = 44.9 V/m; Power Drift = -0.050 dB

Peak SAR (extrapolated) = 3.04 W/kg

**SAR(1 g) = 2.11 mW/g; SAR(10 g) = 1.4 mW/g**

Maximum value of SAR (measured) = 2.28 mW/g

003: System Performance Check 900MHz Head 30 03 15

Date: 30/03/2015

DUT: Dipole 900 MHz; SN: 1d168; Type: D900V2; Serial: SN1d168

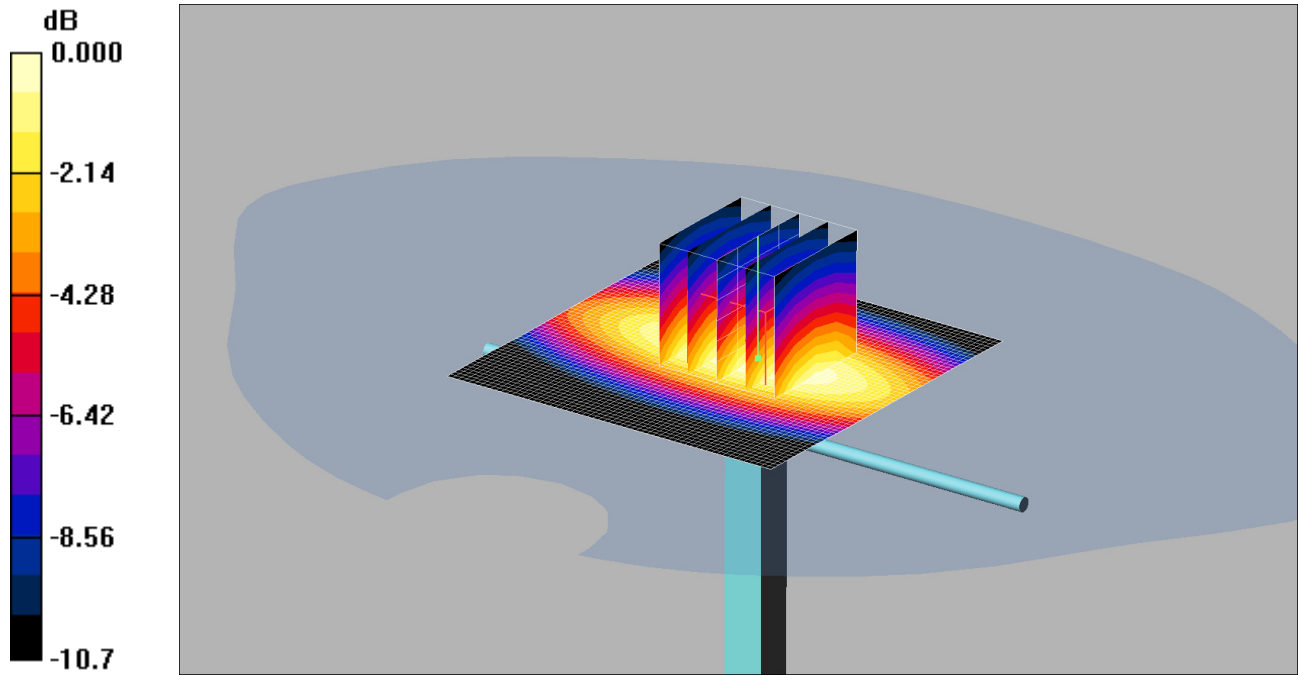

0 dB = 2.70mW/g

Communication System: CW; Frequency: 900 MHz; Duty Cycle: 1:1

Medium: 900 MHz HSL Medium parameters used:  $f = 900 \text{ MHz}$ ;  $\sigma = 0.935 \text{ mho/m}$ ;  $\epsilon_r = 40.9$ ;  $\rho = 1000 \text{ kg/m}^3$

Phantom section: Flat Section

DASY4 Configuration:

- Probe: ET3DV6 - SN1529; ConvF(6.15, 6.15, 6.15);
- Sensor-Surface: 4mm (Mechanical Surface Detection)
- Electronics: DAE3 Sn394; Calibrated: 16/05/2014
- Phantom: SAM 12b (Site 56); Type: SAM 4.0; Serial: TP:1192
- Measurement SW: DASY4, V4.6 Build 19; Postprocessing SW: SEMCAD, V1.8 Build 159

**d=15mm, Pin=250mW/Area Scan (61x61x1):** Measurement grid: dx=15mm, dy=15mm

Maximum value of SAR (interpolated) = 2.74 mW/g

**d=15mm, Pin=250mW/Zoom Scan (5x5x7) (5x5x7)/Cube 0:** Measurement grid: dx=8mm, dy=8mm, dz=5mm

Reference Value = 56.5 V/m; Power Drift = -0.118 dB

Peak SAR (extrapolated) = 3.62 W/kg

**SAR(1 g) = 2.5 mW/g; SAR(10 g) = 1.64 mW/g**

Maximum value of SAR (measured) = 2.70 mW/g

004: System Performance Check 900MHz Head 07 04 15

Date: 07/04/2015

DUT: Dipole 900 MHz; SN: 1d168; Type: D900V2; Serial: SN1d168

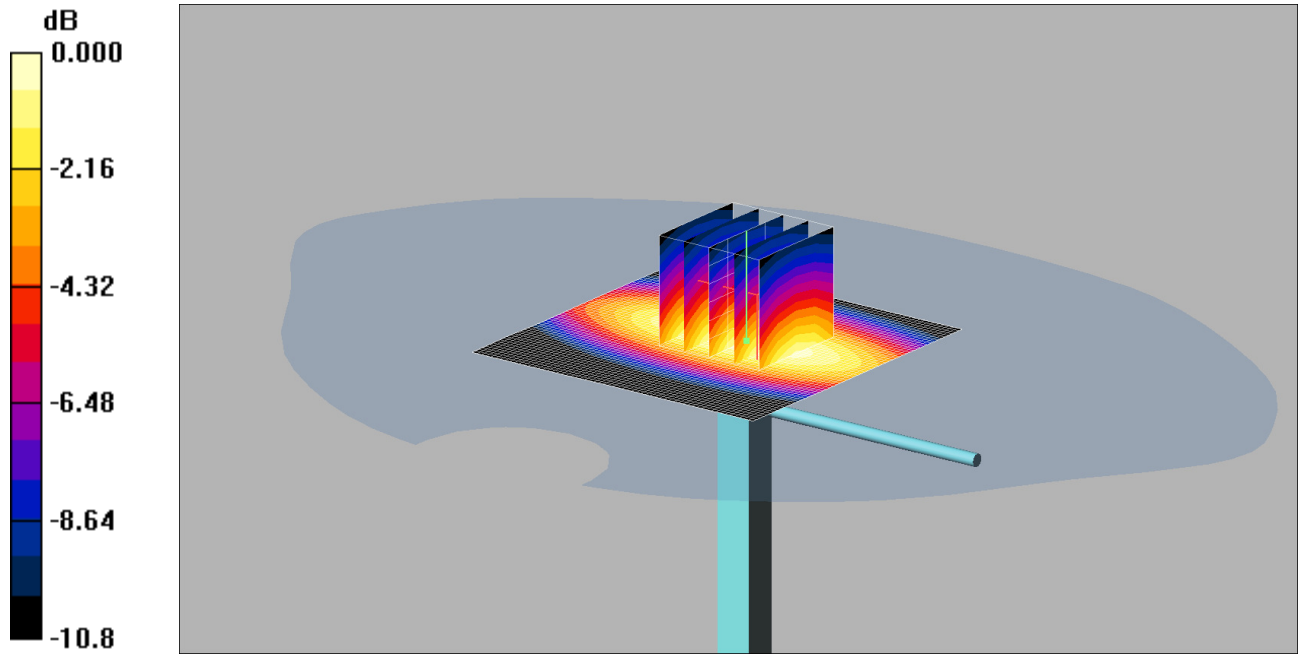

0 dB = 2.84mW/g

Communication System: CW; Frequency: 900 MHz; Duty Cycle: 1:1

Medium: 900 MHz HSL Medium parameters used:  $f = 900 \text{ MHz}$ ;  $\sigma = 0.948 \text{ mho/m}$ ;  $\epsilon_r = 40.7$ ;  $\rho = 1000 \text{ kg/m}^3$

Phantom section: Flat Section

DASY4 Configuration:

- Probe: ET3DV6 - SN1529; ConvF(6.15, 6.15, 6.15);
- Sensor-Surface: 4mm (Mechanical Surface Detection)
- Electronics: DAE3 Sn394; Calibrated: 16/05/2014
- Phantom: SAM 12b (Site 56); Type: SAM 4.0; Serial: TP:1192
- Measurement SW: DASY4, V4.6 Build 19; Postprocessing SW: SEMCAD, V1.8 Build 159

**d=15mm, Pin=250mW/Area Scan (61x61x1):** Measurement grid:  $dx=15\text{mm}$ ,  $dy=15\text{mm}$

Maximum value of SAR (interpolated) = 2.81 mW/g

**d=15mm, Pin=250mW/Zoom Scan (5x5x7) (5x5x7)/Cube 0:** Measurement grid:  $dx=8\text{mm}$ ,  $dy=8\text{mm}$ ,  $dz=5\text{mm}$

Reference Value = 56.3 V/m; Power Drift = 0.049 dB

Peak SAR (extrapolated) = 3.79 W/kg

**SAR(1 g) = 2.61 mW/g; SAR(10 g) = 1.7 mW/g**

Maximum value of SAR (measured) = 2.84 mW/g

005: System Performance Check 900MHz Body 30 03 15

Date: 30/03/2015

DUT: Dipole 900 MHz; SN: 1d168; Type: D900V2; Serial: SN1d168

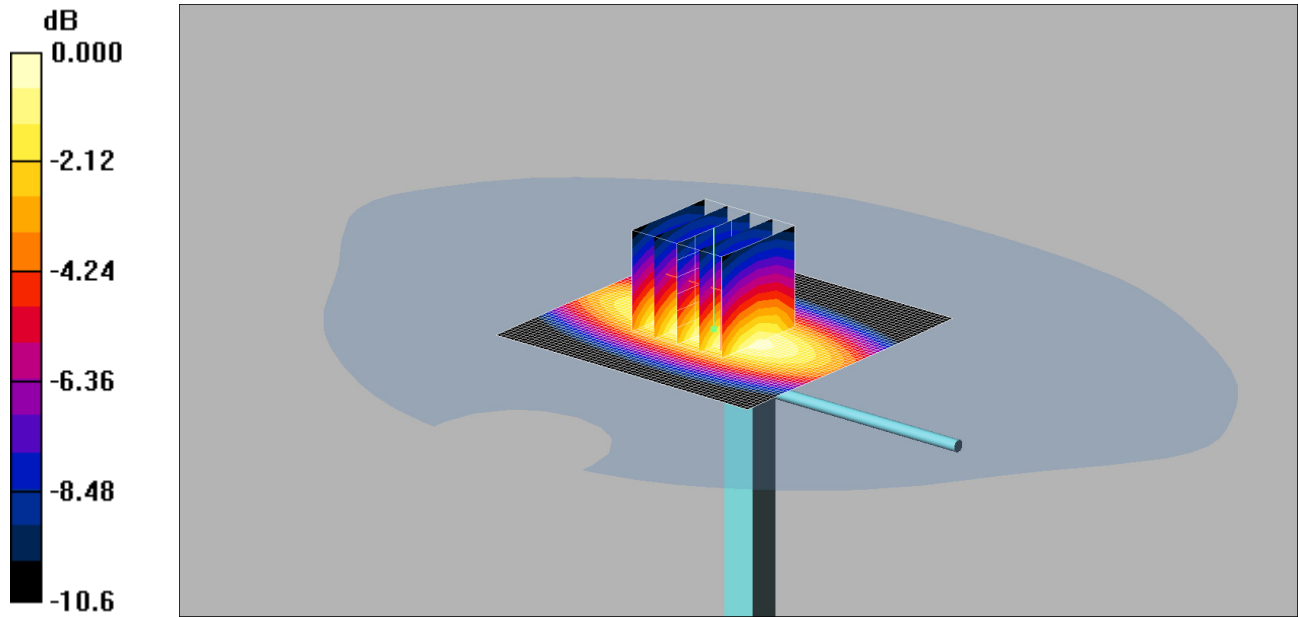

0 dB = 2.87mW/g

Communication System: UMTS-FDD 5; Frequency: 900 MHz; Duty Cycle: 1:1

Medium: 900 MHz MSL Medium parameters used:  $f = 900 \text{ MHz}$ ;  $\sigma = 1.04 \text{ mho/m}$ ;  $\epsilon_r = 53.1$ ;  $\rho = 1000 \text{ kg/m}^3$

Phantom section: Flat Section

DASY4 Configuration:

- Probe: ET3DV6 - SN1529; ConvF(5.85, 5.85, 5.85);
- Sensor-Surface: 4mm (Mechanical Surface Detection)
- Electronics: DAE3 Sn394; Calibrated: 16/05/2014
- Phantom: SAM 12a (Site 56); Type: SAM 4.0; Serial: TP:1020
- Measurement SW: DASY4, V4.6 Build 19; Postprocessing SW: SEMCAD, V1.8 Build 159

**d=15mm, Pin=250mW 2 2/Area Scan (61x61x1):** Measurement grid: dx=15mm, dy=15mm

Maximum value of SAR (interpolated) = 2.85 mW/g

**d=15mm, Pin=250mW 2 2/Zoom Scan (5x5x7) (5x5x7)/Cube 0:** Measurement grid: dx=8mm, dy=8mm, dz=5mm

Reference Value = 50.2 V/m; Power Drift = -0.126 dB

Peak SAR (extrapolated) = 3.61 W/kg

**SAR(1 g) = 2.64 mW/g; SAR(10 g) = 1.75 mW/g**

Maximum value of SAR (measured) = 2.87 mW/g

006: System Performance Check 900MHz Body 07 04 15

Date: 07/04/2015

DUT: Dipole 900 MHz; SN: 1d168; Type: D900V2; Serial: SN1d168

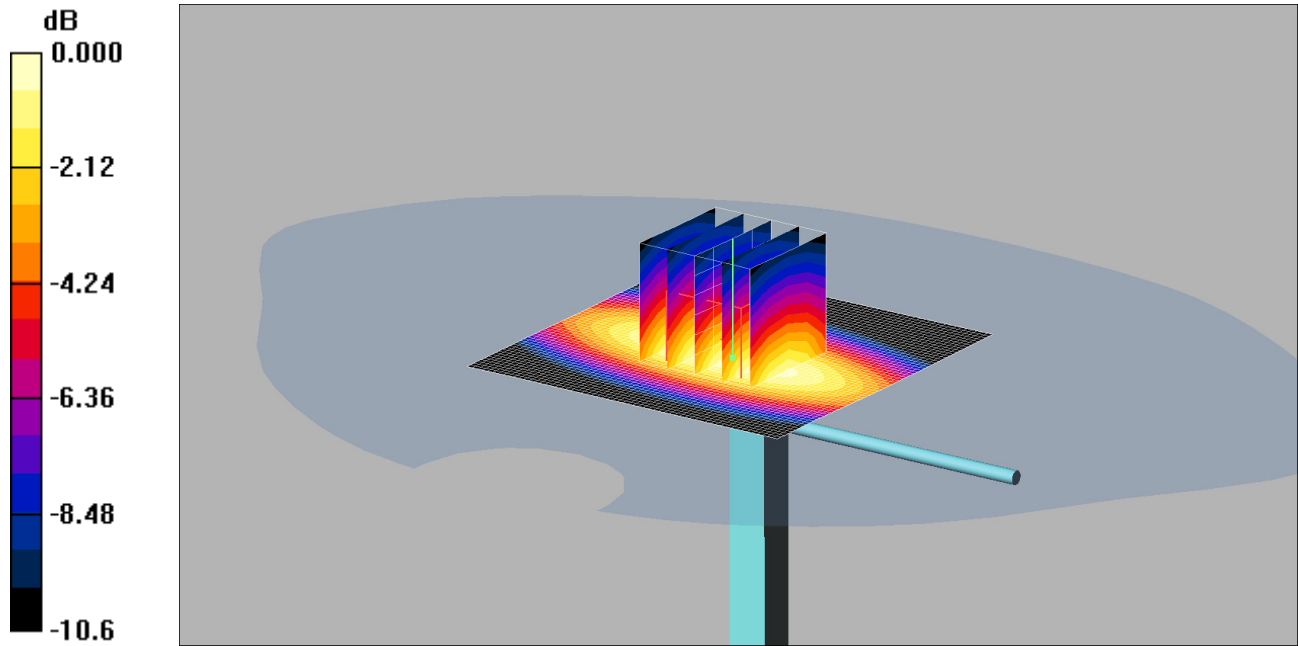

0 dB = 2.93mW/g

Communication System: UMTS-FDD 5; Frequency: 900 MHz; Duty Cycle: 1:1  
 Medium: 900 MHz MSL Medium parameters used:  $f = 900 \text{ MHz}$ ;  $\sigma = 1.06 \text{ mho/m}$ ;  $\epsilon_r = 53.4$ ;  $\rho = 1000 \text{ kg/m}^3$   
 Phantom section: Flat Section  
 DASY4 Configuration:  
 - Probe: ET3DV6 - SN1529; ConvF(5.85, 5.85, 5.85);  
 - Sensor-Surface: 4mm (Mechanical Surface Detection)  
 - Electronics: DAE3 Sn394; Calibrated: 16/05/2014  
 - Phantom: SAM 12a (Site 56); Type: SAM 4.0; Serial: TP:1020  
 - Measurement SW: DASY4, V4.6 Build 19; Postprocessing SW: SEMCAD, V1.8 Build 159

**d=15mm, Pin=250mW 2 2/Area Scan (61x61x1):** Measurement grid: dx=15mm, dy=15mm  
 Maximum value of SAR (interpolated) = 2.90 mW/g  
**d=15mm, Pin=250mW 2 2/Zoom Scan (5x5x7) (5x5x7)/Cube 0:** Measurement grid: dx=8mm, dy=8mm, dz=5mm  
 Reference Value = 50.1 V/m; Power Drift = -0.063 dB  
 Peak SAR (extrapolated) = 3.70 W/kg  
**SAR(1 g) = 2.69 mW/g; SAR(10 g) = 1.78 mW/g**  
 Maximum value of SAR (measured) = 2.93 mW/g

007: System Performance Check 1800MHz Head 13 04 15

Date: 13/04/2015

DUT: Dipole 1800 MHz; Type: D1800V2; Serial: 264

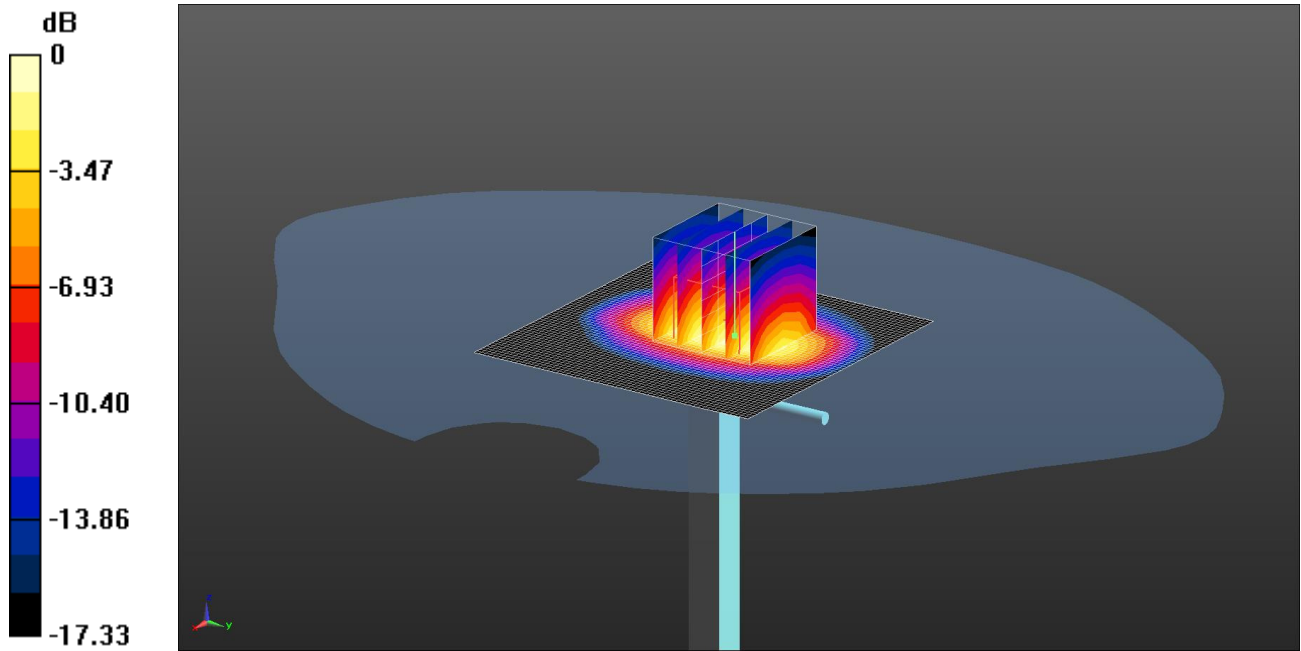

0 dB = 10.8 W/kg = 10.33 dBW/kg

Communication System: UID 0 - n/a, CW; Frequency: 1800 MHz; Duty Cycle: 1:1

Medium: 1800 MHz HSL Medium parameters used:  $f = 1800 \text{ MHz}$ ;  $\sigma = 1.379 \text{ S/m}$ ;  $\epsilon_r = 39.81$ ;  $\rho = 1000 \text{ kg/m}^3$

Phantom section: Flat Section

DASY4 Configuration:

- Probe: ES3DV3 - SN3335; ConvF(5.21, 5.21, 5.21); Calibrated: 29/08/2014;
- Sensor-Surface: 4mm (Mechanical Surface Detection)
- Electronics: DAE3 Sn431; Calibrated: 04/11/2014
- Phantom: SAM B (Site 58); Type: Twin Phantom; Serial: TP:1020
- ; SEMCAD X Version 14.6.9 (7117)

**SAR/d=10mm, Pin=250 mW, dist=10.0mm (ET-Probe)/Area Scan (61x61x1):** Interpolated grid:  $dx=1.500 \text{ mm}$ ,  $dy=1.500 \text{ mm}$

Maximum value of SAR (interpolated) = 11.6 W/kg

**SAR/d=10mm, Pin=250 mW, dist=10.0mm (ET-Probe)/Zoom Scan (5x5x7) (5x5x7)/Cube 0:** Measurement grid:

$dx=8\text{mm}$ ,  $dy=8\text{mm}$ ,  $dz=5\text{mm}$

Reference Value = 88.501 V/m; Power Drift = 0.07 dB

Peak SAR (extrapolated) = 17.4 W/kg

**SAR(1 g) = 9.61 W/kg; SAR(10 g) = 5.1 W/kg**

Maximum value of SAR (measured) = 10.8 W/kg



008: System Performance Check 1800MHz Body 13 04 15

Date: 13/04/2015

DUT: Dipole 1800 MHz; Type: D1800V2; Serial: 264

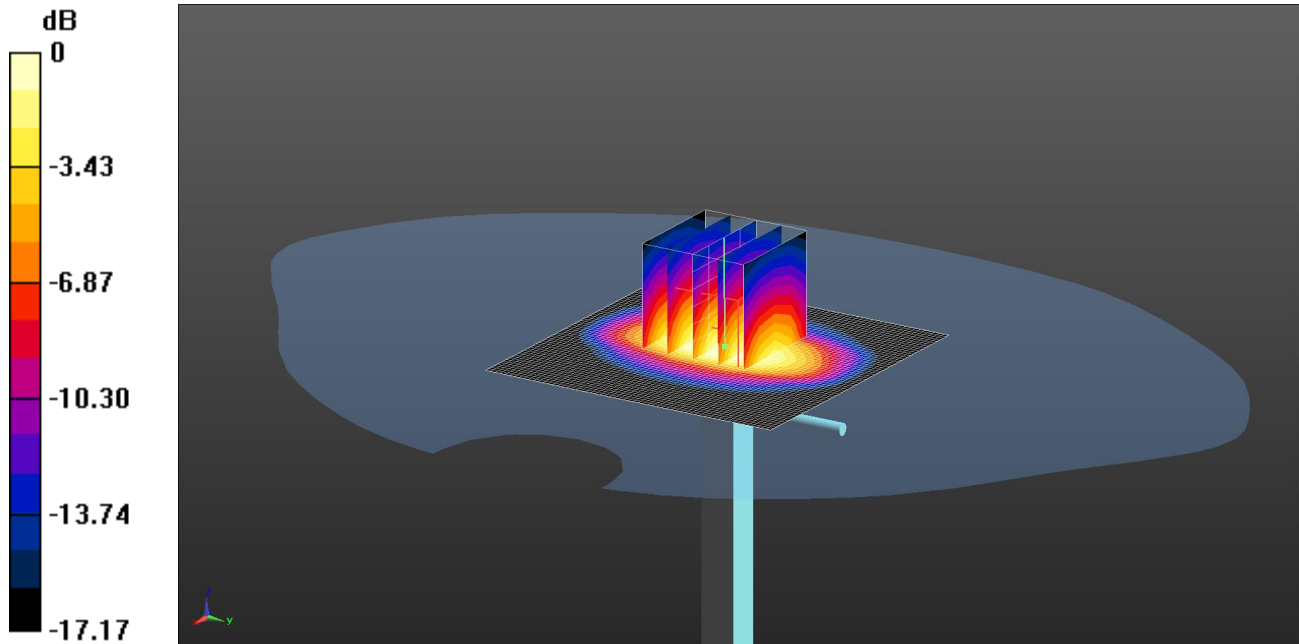

0 dB = 10.9 W/kg = 10.37 dBW/kg

Communication System: UID 0 - n/a, CW; Frequency: 1800 MHz; Duty Cycle: 1:1

Medium: 1800 MHz MSL Medium parameters used:  $f = 1800 \text{ MHz}$ ;  $\sigma = 1.555 \text{ S/m}$ ;  $\epsilon_r = 51.868$ ;  $\rho = 1000 \text{ kg/m}^3$

Phantom section: Flat Section

DASY4 Configuration:

- Probe: ES3DV3 - SN3335; ConvF(4.91, 4.91, 4.91); Calibrated: 29/08/2014;
- Sensor-Surface: 3mm (Mechanical Surface Detection), Sensor-Surface: 4mm (Mechanical Surface Detection)
- Electronics: DAE3 Sn431; Calibrated: 04/11/2014
- Phantom: SAM A (Site 58); Type: QD000P40Ca; Serial: TP:1193
- ; SEMCAD X Version 14.6.9 (7117)

**SAR/d=10mm, Pin=250 mW, dist=10.0mm (ET-Probe) 2/Area Scan (61x61x1):** Interpolated grid: dx=1.500 mm, dy=1.500 mm

Maximum value of SAR (interpolated) = 12.2 W/kg

**SAR/d=10mm, Pin=250 mW, dist=10.0mm (ET-Probe) 2/Zoom Scan (5x5x7) (5x5x7)/Cube 0:** Measurement grid: dx=8mm, dy=8mm, dz=5mm

Reference Value = 92.258 V/m; Power Drift = 0.02 dB

Peak SAR (extrapolated) = 17.2 W/kg

**SAR(1 g) = 9.69 W/kg; SAR(10 g) = 5.08 W/kg**

Maximum value of SAR (measured) = 10.9 W/kg

009: System Performance Check 1900MHz Head 14 04 15

Date: 14/04/2015

DUT: Dipole 1900 MHz; Type: D1900V2; Serial: SN540

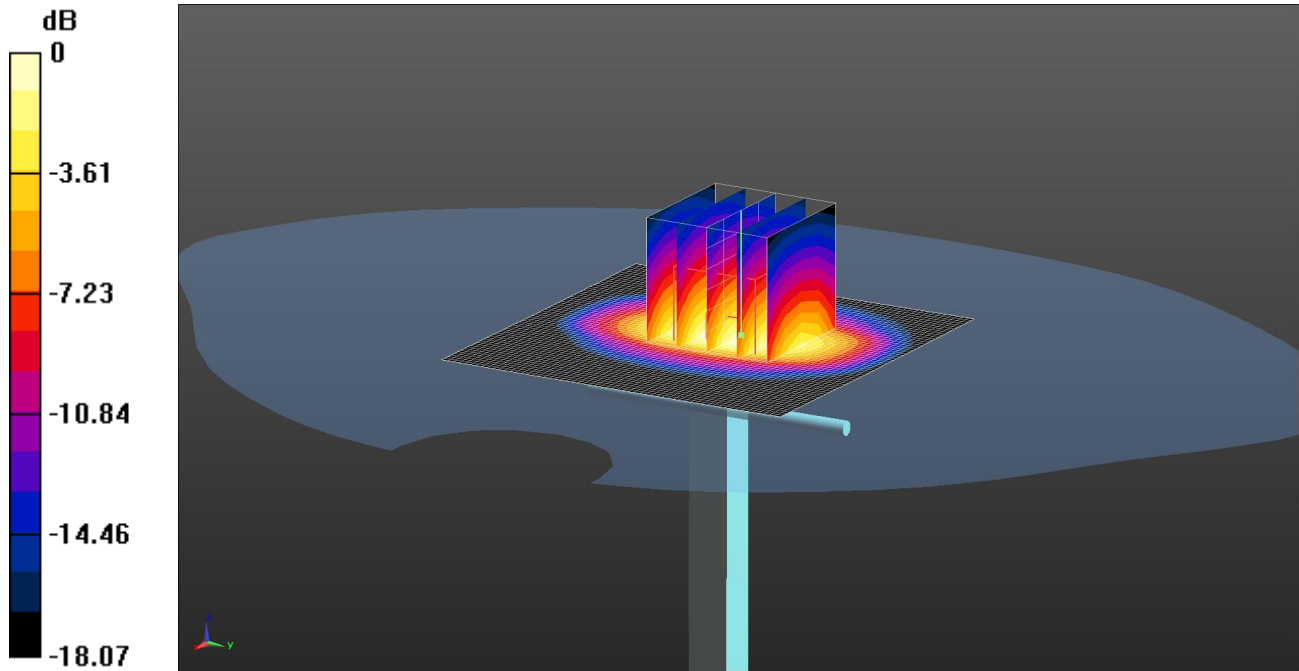

0 dB = 11.3 W/kg = 10.53 dBW/kg

Communication System: UID 0 - n/a, CW (0); Frequency: 1900 MHz; Duty Cycle: 1:1

Medium: 1900 MHz HSL Medium parameters used:  $f = 1900 \text{ MHz}$ ;  $\sigma = 1.43 \text{ S/m}$ ;  $\epsilon_r = 39.034$ ;  $\rho = 1000 \text{ kg/m}^3$

Phantom section: Flat Section

DASY4 Configuration:

- Probe: ES3DV3 - SN3335; ConvF(5.07, 5.07, 5.07); Calibrated: 29/08/2014;
- Sensor-Surface: 4mm (Mechanical Surface Detection)
- Electronics: DAE3 Sn431; Calibrated: 04/11/2014
- Phantom: SAM B (Site 58); Type: Twin Phantom; Serial: TP:1020
- ; SEMCAD X Version 14.6.9 (7117)

**SAR/d=10mm, Pin=250 mW, dist=10.0mm (ET-Probe) 2/Area Scan (61x61x1):** Interpolated grid: dx=1.500 mm, dy=1.500 mm

Maximum value of SAR (interpolated) = 12.0 W/kg

**SAR/d=10mm, Pin=250 mW, dist=10.0mm (ET-Probe) 2/Zoom Scan (5x5x7) (5x5x7)/Cube 0:** Measurement grid: dx=8mm, dy=8mm, dz=5mm

Reference Value = 88.710 V/m; Power Drift = -0.00 dB

Peak SAR (extrapolated) = 18.4 W/kg

**SAR(1 g) = 10 W/kg; SAR(10 g) = 5.23 W/kg**

Maximum value of SAR (measured) = 11.3 W/kg

010: System Performance Check 1900MHz Body 16 04 15

Date: 16/04/15

DUT: Dipole 1900 MHz D1900V2; Type: D1900V2; Serial: D1900V2 - SN: 540

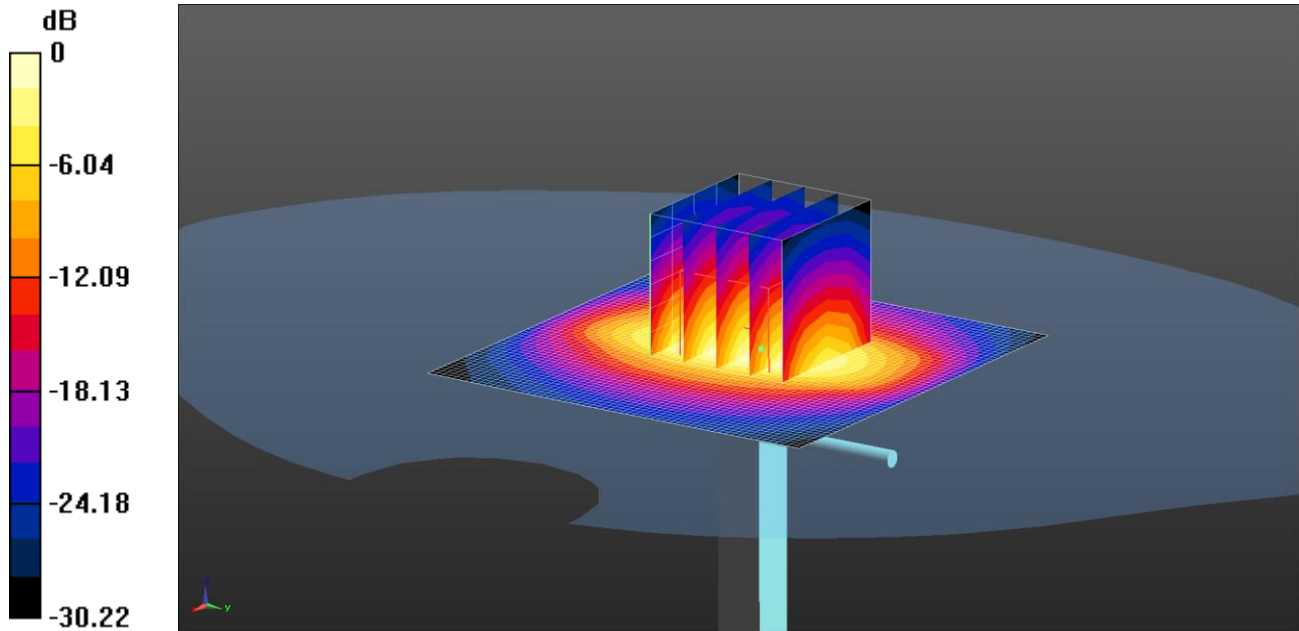

0 dB = 11.6 W/kg = 10.63 dBW/kg

Communication System: UID 0, CW; Frequency: 1900 MHz; Duty Cycle: 1:1

Medium: 1900 MHz MSL Medium parameters used:  $f = 1900$  MHz;  $\sigma = 1.575$  S/m;  $\epsilon_r = 54.168$ ;  $\rho = 1000$  kg/m<sup>3</sup>

Phantom section: Flat Section

DASY4 Configuration:

- Probe: ES3DV3 - SN3335; ConvF(4.69, 4.69, 4.69); Calibrated: 29/08/14;
- Sensor-Surface: 4mm (Mechanical Surface Detection)
- Electronics: DAE3 Sn431; Calibrated: 04/11/14
- Phantom: SAM A (Site 58); Type: QD000P40Ca; Serial: TP:1193
- ; SEMCAD X Version 14.6.10 (7331)

**SAR/d=10mm, Pin=250 mW, dist=10.0mm (ET-Probe) 2 2/Area Scan (61x61x1):** Interpolated grid: dx=1.500 mm, dy=1.500 mm

Maximum value of SAR (interpolated) = 11.6 W/kg

**SAR/d=10mm, Pin=250 mW, dist=10.0mm (ET-Probe) 2 2/Zoom Scan (5x5x7) (5x5x7)/Cube 0:** Measurement grid:

dx=8mm, dy=8mm, dz=5mm

Reference Value = 86.88 V/m; Power Drift = -0.01 dB

Peak SAR (extrapolated) = 18.2 W/kg

**SAR(1 g) = 10.1 W/kg; SAR(10 g) = 5.21 W/kg**

Maximum value of SAR (measured) = 11.3 W/kg

011: System Performance Check 2450MHz Head 14 04 15

Date: 14/04/2015

DUT: Dipole 2450 MHz; SN725; Type: D2450V2; Serial: D2450V2 - SN:725

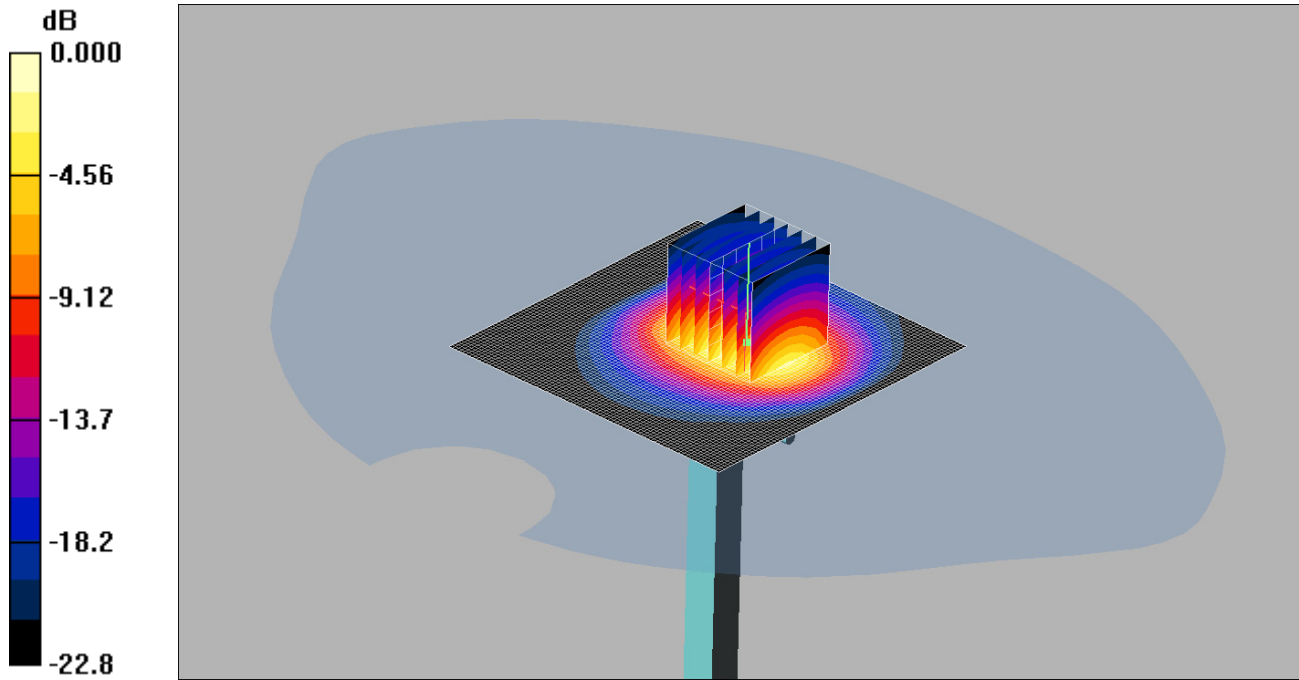

0 dB = 14.6mW/g

Communication System: CW; Frequency: 2450 MHz; Duty Cycle: 1:1

Medium: 2450 MHz HSL Medium parameters used:  $f = 2450 \text{ MHz}$ ;  $\sigma = 1.83 \text{ mho/m}$ ;  $\epsilon_r = 38$ ;  $\rho = 1000 \text{ kg/m}^3$

Phantom section: Flat Section

DASY4 Configuration:

- Probe: ES3DV3 - SN3304; ConvF(4.48, 4.48, 4.48);
- Sensor-Surface: 4mm (Mechanical Surface Detection)
- Electronics: DAE3 Sn432; Calibrated: 20/08/2014
- Phantom: SAM 12a (Site 57); Type: SAM 4.0; Serial: TP:1020
- Measurement SW: DASY4, V4.7 Build 80; Postprocessing SW: SEMCAD, V1.8 Build 186

**d=10mm, Pin=250mW/Area Scan (81x81x1):** Measurement grid: dx=12mm, dy=12mm  
 Maximum value of SAR (interpolated) = 15.4 mW/g

**d=10mm, Pin=250mW/Zoom Scan (7x7x7) (7x7x7)/Cube 0:** Measurement grid: dx=5mm, dy=5mm, dz=5mm  
 Reference Value = 81.3 V/m; Power Drift = -0.088 dB  
 Peak SAR (extrapolated) = 28.4 W/kg  
**SAR(1 g) = 13 mW/g; SAR(10 g) = 5.98 mW/g**  
 Maximum value of SAR (measured) = 14.6 mW/g

012: System Performance Check 2450MHz Body 07 04 15

Date: 07/04/2015

DUT: Dipole 2450 MHz; Type: D2440V2; Serial: D2440V2 - SN:725

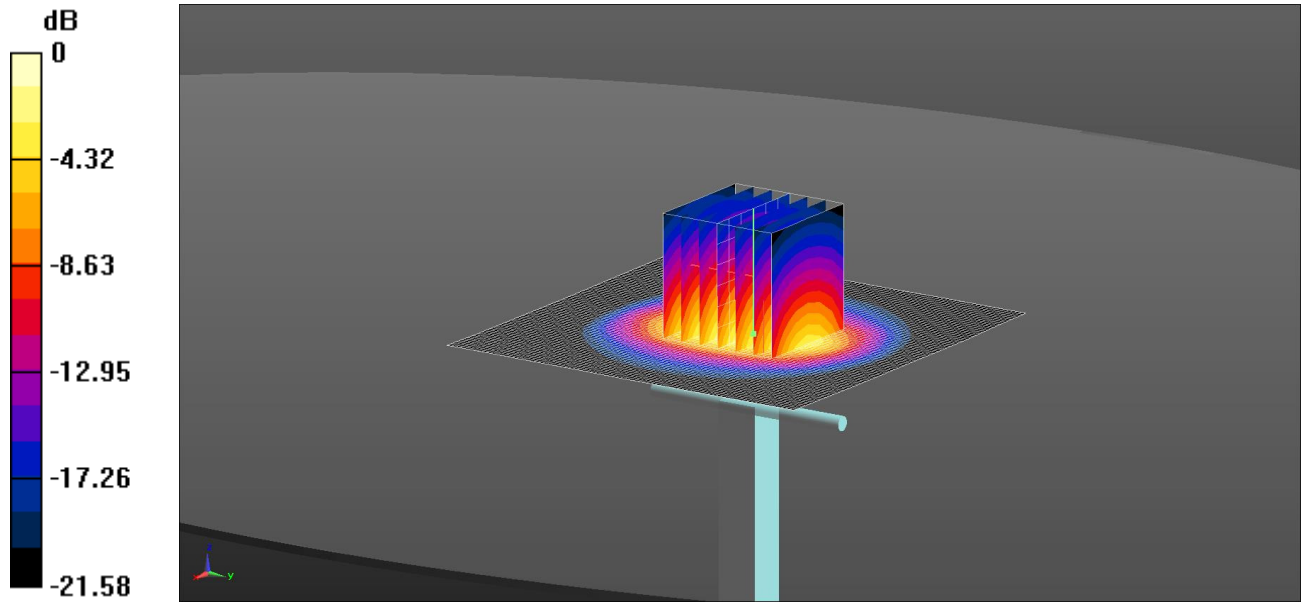

0 dB = 14.1 W/kg = 11.49 dBW/kg

Communication System: UID 0 - n/a, CW; Frequency: 2450 MHz; Duty Cycle: 1:1

Medium: 2450 MHz MSL Medium parameters used:  $f = 2450$  MHz;  $\sigma = 2.023$  S/m;  $\epsilon_r = 52.564$ ;  $\rho = 1000$  kg/m<sup>3</sup>

Phantom section: Flat Section

DASY4 Configuration:

- Probe: ES3DV3 - SN3304; ConvF(4.24, 4.24, 4.24); Calibrated: 21/08/2014;
- Sensor-Surface: 4mm (Mechanical Surface Detection)
- Electronics: DAE3 Sn432; Calibrated: 20/08/2014
- Phantom: ELI v5.0; Type: QDOVA002AA; Serial: TP:xxxx
- ; SEMCAD X Version 14.6.9 (7117)

**Configuration/d=10mm, Pin=250mW/Area Scan (81x81x1):** Interpolated grid: dx=1.200 mm, dy=1.200 mm

Maximum value of SAR (interpolated) = 14.6 W/kg

**Configuration/d=10mm, Pin=250mW/Zoom Scan (7x7x7) (7x7x7)/Cube 0:** Measurement grid: dx=5mm, dy=5mm, dz=5mm

Reference Value = 83.403 V/m; Power Drift = -0.13 dB

Peak SAR (extrapolated) = 25.9 W/kg

**SAR(1 g) = 12.3 W/kg; SAR(10 g) = 5.69 W/kg**

Maximum value of SAR (measured) = 14.1 W/kg

013: System Performance Check 2450MHz Body 29 04 15

Date: 29/04/2015

DUT: Dipole 2450 MHz; Type: D2450V2; Serial: D2450V2 - SN:725

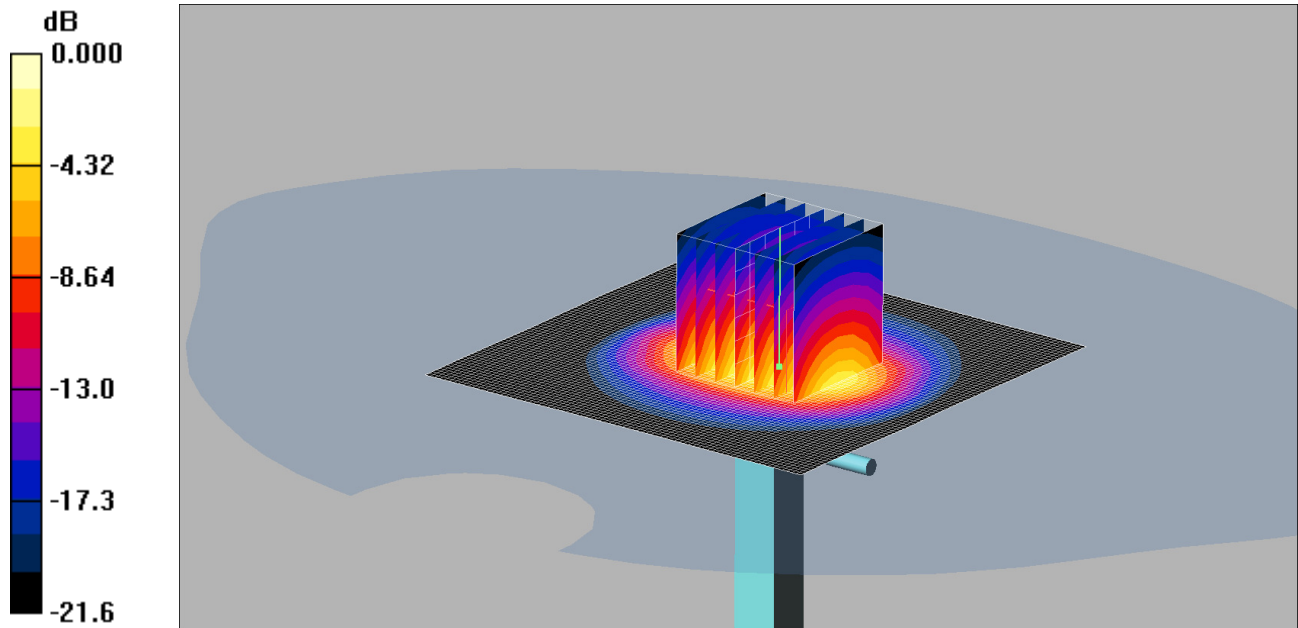

0 dB = 13.5mW/g

Communication System: CW; Frequency: 2450 MHz; Duty Cycle: 1:1

Medium: 2450 MHz MSL Medium parameters used:  $f = 2450$  MHz;  $\sigma = 1.95$  mho/m;  $\epsilon_r = 51.9$ ;  $\rho = 1000$  kg/m<sup>3</sup>

Phantom section: Flat Section

DASY4 Configuration:

- Probe: ET3DV6 - SN1529; ConvF(3.95, 3.95, 3.95);
- Sensor-Surface: 4mm (Mechanical Surface Detection)
- Electronics: DAE3 Sn394; Calibrated: 16/05/2014
- Phantom: SAM 12b (Site 56); Type: SAM 4.0; Serial: TP:1192
- Measurement SW: DASY4, V4.6 Build 19; Postprocessing SW: SEMCAD, V1.8 Build 159

d=10mm, Pin=250mW 2 2 2/Area Scan (81x81x1): Measurement grid: dx=12mm, dy=12mm

Maximum value of SAR (interpolated) = 14.2 mW/g

d=10mm, Pin=250mW 2 2 2/Zoom Scan (7x7x7) (7x7x7)/Cube 0: Measurement grid: dx=5mm, dy=5mm, dz=5mm

Reference Value = 86.1 V/m; Power Drift = 0.003 dB

Peak SAR (extrapolated) = 28.7 W/kg

SAR(1 g) = 12.3 mW/g; SAR(10 g) = 5.65 mW/g

Maximum value of SAR (measured) = 13.5 mW/g

014: System Performance Check 5250MHz Head 16 04 15

Date: 16/04/2015

DUT: 5GHz Dipole; Type: D5GHzV2; Serial: SN 1016

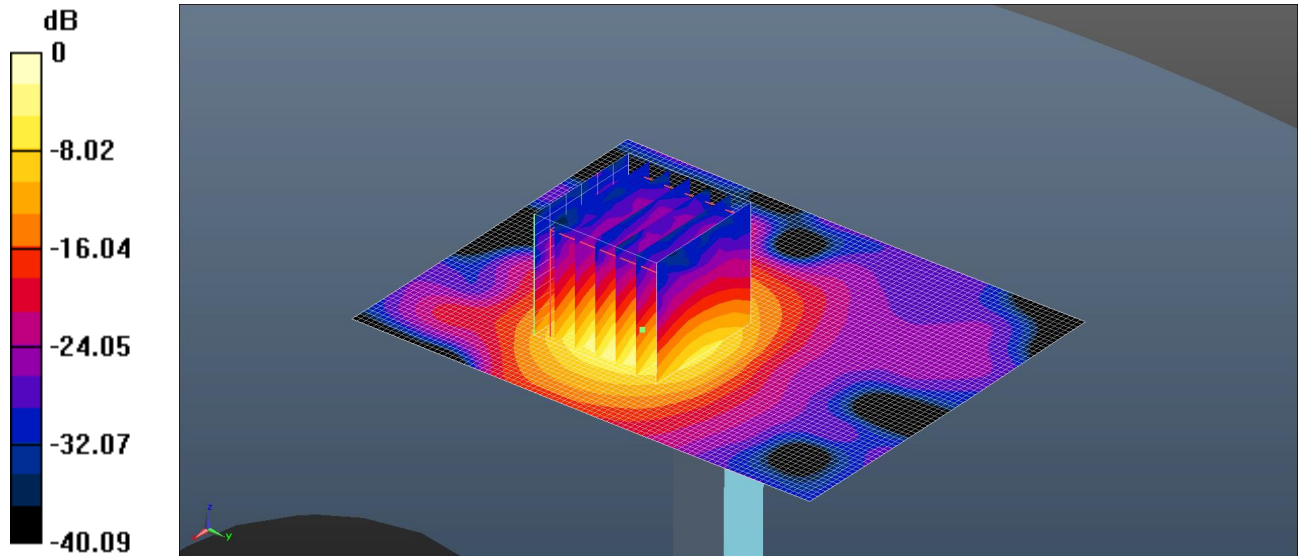

0 dB = 16.7 W/kg = 12.23 dBW/kg

Communication System: UID 0, CW (0); Frequency: 5250 MHz; Duty Cycle: 1:1

Medium: 5200/5500/5800 MHz HSL Medium parameters used:  $f = 5250$  MHz;  $\sigma = 4.585$  S/m;  $\epsilon_r = 34.482$ ;  $\rho = 1000$  kg/m<sup>3</sup>

Phantom section: Flat Section

DASY4 Configuration:

- Probe: EX3DV4 - SN3994; ConvF(5.3, 5.3, 5.3); Calibrated: 17/03/2015;
- Sensor-Surface: 2mm (Mechanical Surface Detection)
- Electronics: DAE3 Sn450; Calibrated: 16/09/2014
- Phantom: SAM (20deg probe tilt) with CRP v4.0; Type: QD000P40CC; Serial: TP:xxxx
- ; SEMCAD X Version 14.6.10 (7164)

**Configuration/d=10mm, Pin=100mW 2 2 2/Area Scan (71x91x1):** Interpolated grid: dx=1.000 mm, dy=1.000 mm

Maximum value of SAR (interpolated) = 17.0 W/kg

**Configuration/d=10mm, Pin=100mW 2 2 2/Zoom Scan (7x7x12) (7x7x12)/Cube 0:** Measurement grid: dx=4mm, dy=4mm, dz=2mm

Reference Value = 21.785 V/m; Power Drift = -0.12 dB

Peak SAR (extrapolated) = 34.3 W/kg

**SAR(1 g) = 8.09 W/kg; SAR(10 g) = 2.25 W/kg**

Maximum value of SAR (measured) = 16.7 W/kg

015: System Performance Check 5250MHz Body 13 04 15

Date: 13/04/15

DUT: 5GHz Dipole; Type: D5GHzV2; Serial: SN 1016

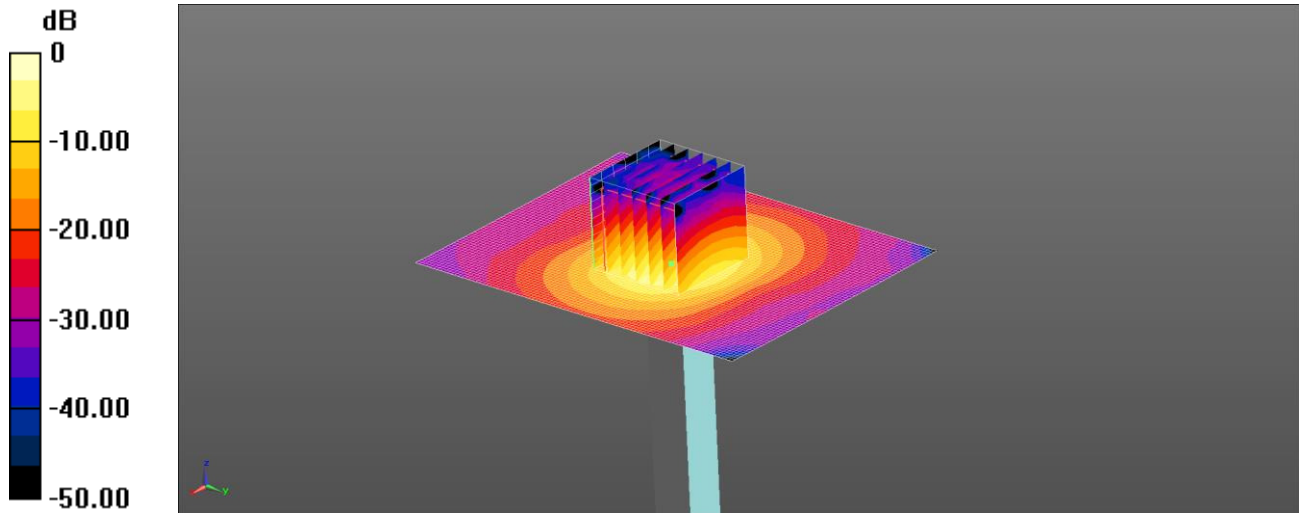

0 dB = 15.6 W/kg = 11.93 dBW/kg

Communication System: UID 0, CW (0); Frequency: 5250 MHz; Duty Cycle: 1:1

Medium: 5GHz MSL Medium parameters used:  $f = 5250$  MHz;  $\sigma = 5.338$  S/m;  $\epsilon_r = 48.275$ ;  $\rho = 1000$  kg/m<sup>3</sup>

Phantom section: Flat Section

DASY4 Configuration:

- Probe: EX3DV4 - SN3814; ConvF(4.38, 4.38, 4.38); Calibrated: 18/09/14;

- Sensor-Surface: 2mm (Mechanical Surface Detection)

- Electronics: DAE4 Sn1435; Calibrated: 15/04/14

- Phantom: ELI v5.0 (30deg probe tilt); Type: QDOVA002AA; Serial: TP:xxxx

- ; SEMCAD X Version 14.6.10 (7331)

**Configuration/d=10mm, Pin=100mW/Area Scan (71x91x1):** Interpolated grid: dx=1.000 mm, dy=1.000 mm

Maximum value of SAR (interpolated) = 16.1 W/kg

**Configuration/d=10mm, Pin=100mW/Zoom Scan (7x7x12) (7x7x12)/Cube 0:** Measurement grid: dx=4mm, dy=4mm, dz=2mm

Reference Value = 38.47 V/m; Power Drift = 0.02 dB

Peak SAR (extrapolated) = 30.4 W/kg

**SAR(1 g) = 7.38 W/kg; SAR(10 g) = 2.03 W/kg**

Maximum value of SAR (measured) = 15.6 W/kg



016: System Performance Check 5600MHz Head 16 04 15

Date: 16/04/2015

DUT: 5GHz Dipole; Type: D5GHzV2; Serial: SN 1016

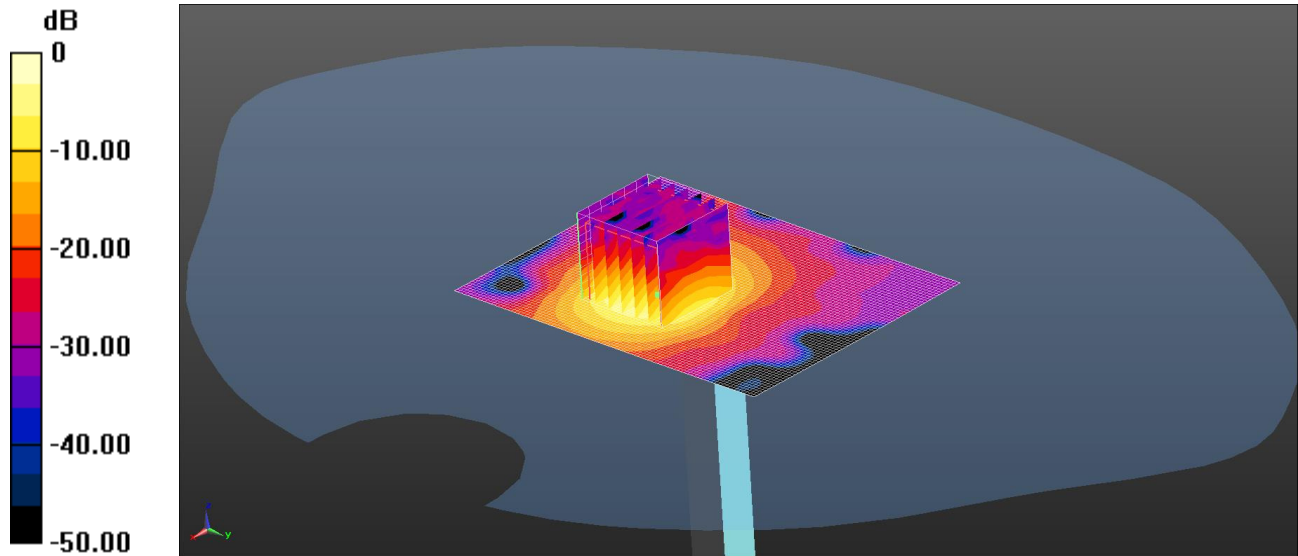

0 dB = 17.1 W/kg = 12.33 dBW/kg

Communication System: UID 0, CW (0); Frequency: 5600 MHz; Duty Cycle: 1:1

Medium: 5200/5500/5800 MHz HSL Medium parameters used:  $f = 5600$  MHz;  $\sigma = 4.951$  S/m;  $\epsilon_r = 33.972$ ;  $\rho = 1000$  kg/m<sup>3</sup>

Phantom section: Flat Section

DASY4 Configuration:

- Probe: EX3DV4 - SN3994; ConvF(4.77, 4.77, 4.77); Calibrated: 17/03/2015;
- Sensor-Surface: 2mm (Mechanical Surface Detection)
- Electronics: DAE3 Sn450; Calibrated: 16/09/2014
- Phantom: SAM (20deg probe tilt) with CRP v4.0; Type: QD000P40CC; Serial: TP:xxxx
- ; SEMCAD X Version 14.6.10 (7164)

**Configuration/d=10mm, Pin=100mW 2 2 2/Area Scan (71x91x1):** Interpolated grid: dx=1.000 mm, dy=1.000 mm

Maximum value of SAR (interpolated) = 17.2 W/kg

**Configuration/d=10mm, Pin=100mW 2 2 2/Zoom Scan (7x7x12) (7x7x12)/Cube 0:** Measurement grid: dx=4mm, dy=4mm, dz=2mm

Reference Value = 20.664 V/m; Power Drift = -0.20 dB

Peak SAR (extrapolated) = 37.4 W/kg

**SAR(1 g) = 8.05 W/kg; SAR(10 g) = 2.21 W/kg**

Maximum value of SAR (measured) = 17.1 W/kg

017: System Performance Check 5600MHz Body 13 04 15

Date: 13/04/15

DUT: 5GHz Dipole; Type: D5GHzV2; Serial: SN 1016

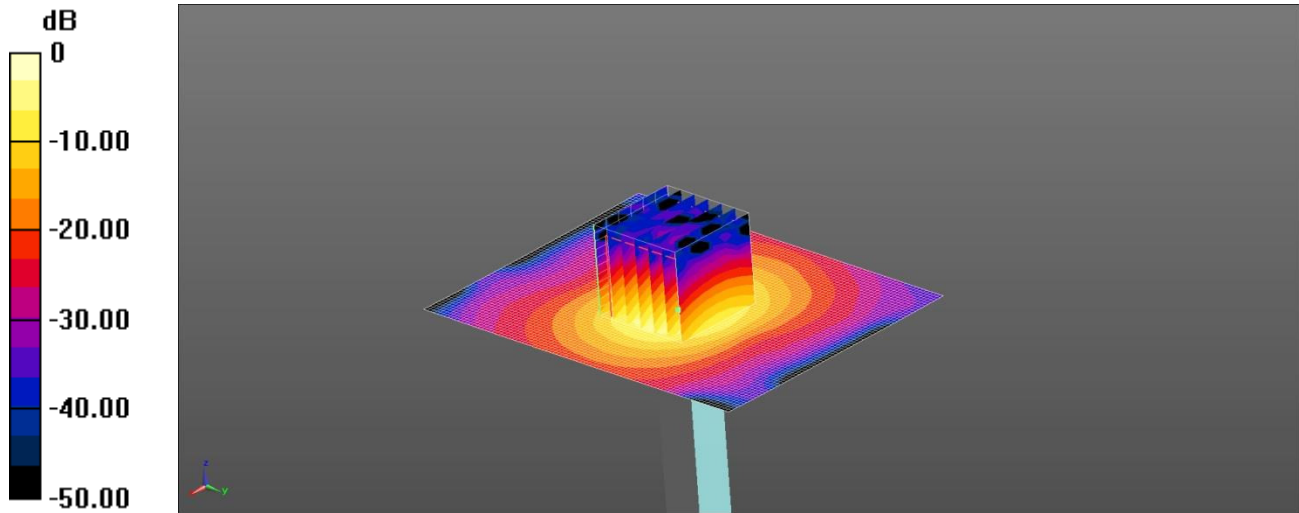

0 dB = 16.3 W/kg = 12.12 dBW/kg

Communication System: UID 0, CW (0); Frequency: 5600 MHz; Duty Cycle: 1:1

Medium: 5GHz MSL Medium parameters used:  $f = 5600$  MHz;  $\sigma = 5.889$  S/m;  $\epsilon_r = 47.431$ ;  $\rho = 1000$  kg/m<sup>3</sup>

Phantom section: Flat Section

DASY4 Configuration:

- Probe: EX3DV4 - SN3814; ConvF(3.79, 3.79, 3.79); Calibrated: 18/09/14;
- Sensor-Surface: 2mm (Mechanical Surface Detection)
- Electronics: DAE4 Sn1435; Calibrated: 15/04/14
- Phantom: ELI v5.0 (30deg probe tilt); Type: QDOVA002AA; Serial: TP:xxxx
- ; SEMCAD X Version 14.6.10 (7331)

**Configuration/d=10mm, Pin=100mW/Area Scan (71x91x1):** Interpolated grid: dx=1.000 mm, dy=1.000 mm

Maximum value of SAR (interpolated) = 16.5 W/kg

**Configuration/d=10mm, Pin=100mW/Zoom Scan (7x7x12) (7x7x12)/Cube 0:** Measurement grid: dx=4mm, dy=4mm, dz=2mm

Reference Value = 36.11 V/m; Power Drift = -0.20 dB

Peak SAR (extrapolated) = 33.9 W/kg

**SAR(1 g) = 7.53 W/kg; SAR(10 g) = 2.04 W/kg**

Maximum value of SAR (measured) = 16.3 W/kg

018: System Performance Check 5750MHz Head 16 04 15

Date: 16/04/2015

DUT: 5GHz Dipole; Type: D5GHzV2; Serial: SN 1016

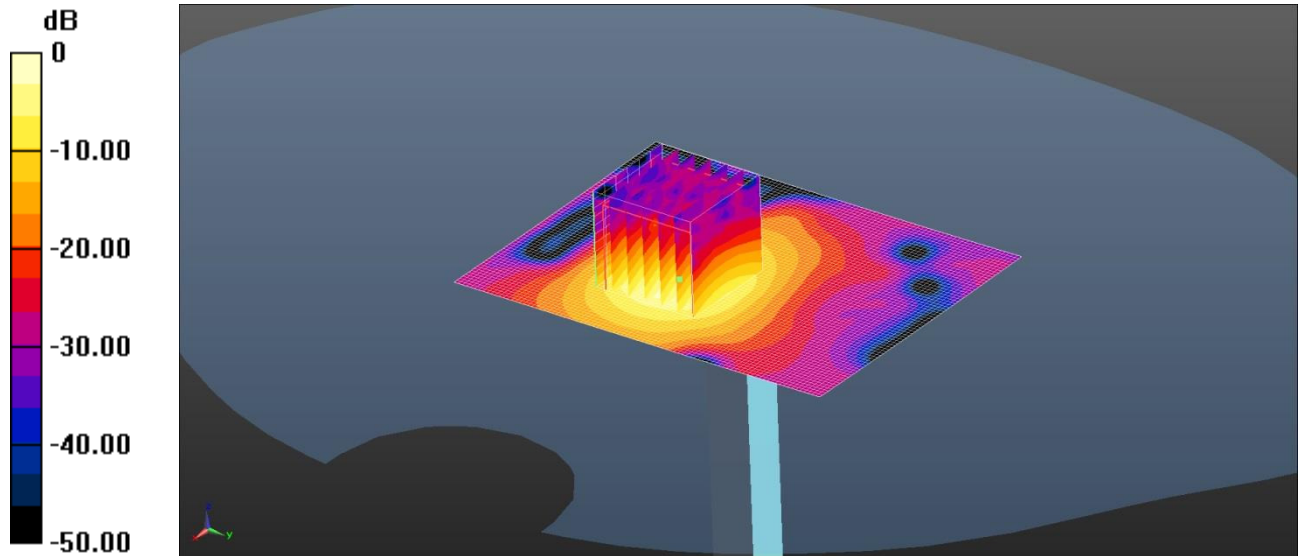

0 dB = 16.4 W/kg = 12.15 dBW/kg

Communication System: UID 0, CW (0); Frequency: 5750 MHz; Duty Cycle: 1:1

Medium: 5200/5500/5800 MHz HSL Medium parameters used:  $f = 5750$  MHz;  $\sigma = 5.124$  S/m;  $\epsilon_r = 33.84$ ;  $\rho = 1000$  kg/m<sup>3</sup>

Phantom section: Flat Section

DASY4 Configuration:

- Probe: EX3DV4 - SN3994; ConvF(4.73, 4.73, 4.73); Calibrated: 17/03/2015;
- Sensor-Surface: 2mm (Mechanical Surface Detection)
- Electronics: DAE3 Sn450; Calibrated: 16/09/2014
- Phantom: SAM (20deg probe tilt) with CRP v4.0; Type: QD000P40CC; Serial: TP:xxxx
- ; SEMCAD X Version 14.6.10 (7164)

**Configuration/d=10mm, Pin=100mW 2 2/Area Scan (71x91x1):** Interpolated grid: dx=1.000 mm, dy=1.000 mm

Maximum value of SAR (interpolated) = 16.2 W/kg

**Configuration/d=10mm, Pin=100mW 2 2/Zoom Scan (7x7x12) (7x7x12)/Cube 0:** Measurement grid: dx=4mm, dy=4mm, dz=2mm

Reference Value = 20.536 V/m; Power Drift = -0.15 dB

Peak SAR (extrapolated) = 34.6 W/kg

**SAR(1 g) = 7.83 W/kg; SAR(10 g) = 2.2 W/kg**

Maximum value of SAR (measured) = 16.4 W/kg

019: System Performance Check 5750MHz Body 13 04 15

Date: 13/04/15

DUT: 5GHz Dipole; Type: D5GHzV2; Serial: SN 1016

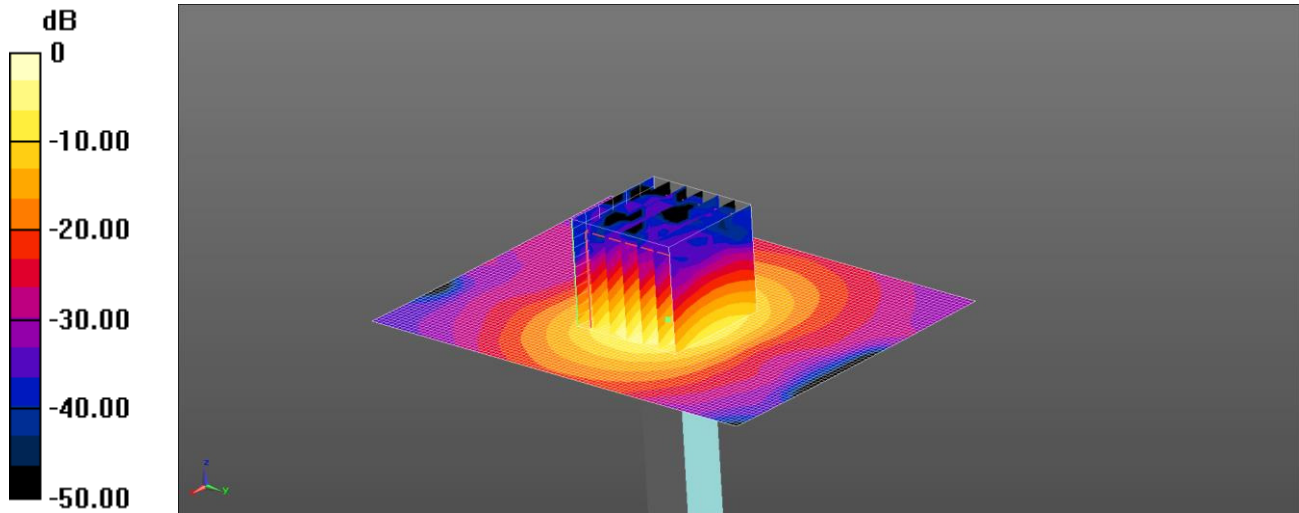

0 dB = 16.1 W/kg = 12.07 dBW/kg

Communication System: UID 0, CW (0); Frequency: 5750 MHz; Duty Cycle: 1:1

Medium: 5GHz MSL Medium parameters used:  $f = 5750$  MHz;  $\sigma = 6.131$  S/m;  $\epsilon_r = 47.05$ ;  $\rho = 1000$  kg/m<sup>3</sup>

Phantom section: Flat Section

DASY4 Configuration:

- Probe: EX3DV4 - SN3814; ConvF(4.06, 4.06, 4.06); Calibrated: 18/09/14;
- Sensor-Surface: 2mm (Mechanical Surface Detection)
- Electronics: DAE4 Sn1435; Calibrated: 15/04/14
- Phantom: ELI v5.0 (30deg probe tilt); Type: QDOVA002AA; Serial: TP:xxxx
- ; SEMCAD X Version 14.6.10 (7331)

**Configuration/d=10mm, Pin=100mW/Area Scan (71x91x1):** Interpolated grid: dx=1.000 mm, dy=1.000 mm

Maximum value of SAR (interpolated) = 16.8 W/kg

**Configuration/d=10mm, Pin=100mW/Zoom Scan (7x7x12) (7x7x12)/Cube 0:** Measurement grid: dx=4mm, dy=4mm, dz=2mm

Reference Value = 34.34 V/m; Power Drift = -0.21 dB

Peak SAR (extrapolated) = 34.4 W/kg

**SAR(1 g) = 7.4 W/kg; SAR(10 g) = 2 W/kg**

Maximum value of SAR (measured) = 16.1 W/kg

**12.3. SAR Test Plots – A1428**

This appendix contains the following SAR distribution scans.

Scan Reference Number	Title
001	Touch Left_GSM850_Voice_CH190
002	Back of EUT-Body-Worn_GSM850_Voice_CH190
003	Back of EUT-Hotspot_GSM850_GPRS 2Tx_CH251
004	Touch Right_PCS1900_Voice_CH512
005	Back of EUT_Body-Worn_PCS1900_Voice_CH661
006	Back of EUT_Body-Worn_PCS1900_GPRS 2Tx_CH810
007	Touch Right_UMTS FDD 2_RMC 12.2kbps_CH9262
008	Back of EUT_Body-Worn_UMTS FDD 2_RMC 12.2kbps_CH9400
009	Touch Right_UMTS FDD 4_RMC 12.2kbps_CH1413
010	Front of EUT-Body-Worn_UMTS FDD 4_RMC 12.2kbps_CH1413
011	Touch Left_UMTS FDD 5_RMC 12.2kbps_CH4233
012	Back of EUT-Body-Worn_UMTS FDD 5_RMC 12.2kbps_CH4233
013	Back of EUT_Body-Worn_LTE FDD 2_20MHz 1RB Mid_CH18900
014	Touch Right_LTE FDD 4_20MHz 1RB High_CH20050
015	Touch Right_LTE FDD 4_20MHz 1RB High_CH20300
016	Touch Right_LTE FDD 4_20MHz 1RB Low_CH20050
017	Touch Right_LTE FDD 4_20MHz 1RB Mid_CH20300
018	Back of EUT-Body-Worn_LTE FDD 4_20MHz 1RB Mid_CH20175
019	Front of EUT-Body-Worn_LTE FDD 5_10MHz 1RB Mid_CH20525
020	Front of EUT-Body-Worn_LTE FDD 17_10MHz 1RB Mid_CH23790
021	Touch Right_Wi-Fi 2.4GHz_802.11b 1Mbps_CH6
022	Back of EUT-Body-Worn_Wi-Fi 2.4GHz_802.11b 1Mbps_CH6
023	Touch Right_Wi-Fi_5GHz_802.11a_6Mbps_CH48
024	Front of EUT-Body-Worn_Wi-Fi 5GHz_802.11a 6Mbps_CH48
025	Touch Right_Wi-Fi_5GHz_802.11a_6Mbps_CH52
026	Front of EUT-Body-Worn_Wi-Fi 5GHz_802.11a 6Mbps_CH64
027	Touch Right_Wi-Fi_5GHz_802.11a_6Mbps_CH136
028	Front of EUT-Body-Worn_Wi-Fi 5GHz_802.11a 6Mbps_CH124
029	Touch Right_Wi-Fi_5GHz_802.11a_6Mbps_CH157
030	Front of EUT-Body-Worn_Wi-Fi 5GHz_802.11a 6Mbps_CH149
031	Back of EUT-Body-Worn_Bluetooth_1Mbps_CH39

001: Touch Left\_GSM850\_Voice\_CH190

Date: 31/03/2015

DUT: A1428; Sleeve: Linea Pro 5; Sleeve contains FCC ID: YRWDATECSBT301

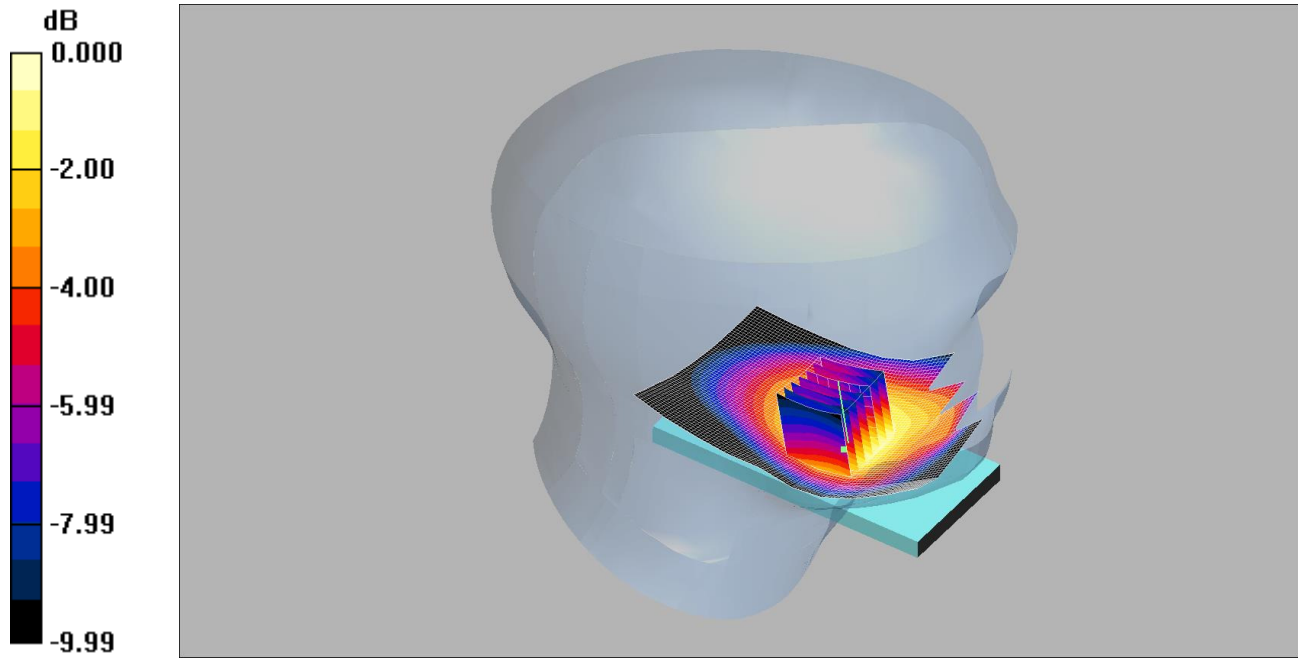

0 dB = 0.139mW/g

Communication System: GSM 850 MHz; Frequency: 836.6 MHz; Duty Cycle: 1:8.3

Medium: 900 MHz HSL Medium parameters used (interpolated):  $f = 836.6$  MHz;  $\sigma = 0.889$  mho/m;  $\epsilon_r = 41.3$ ;  $\rho = 1000$  kg/m<sup>3</sup>

Phantom section: Left Section

DASY4 Configuration:

- Probe: ET3DV6 - SN1529; ConvF(6.28, 6.28, 6.28);
- Sensor-Surface: 4mm (Mechanical Surface Detection)
- Electronics: DAE3 Sn394; Calibrated: 16/05/2014
- Phantom: SAM 12b (Site 56); Type: SAM 4.0; Serial: TP:1192
- Measurement SW: DASY4, V4.6 Build 19; Postprocessing SW: SEMCAD, V1.8 Build 159

**Touch Left - Middle/Area Scan (61x101x1):** Measurement grid: dx=15mm, dy=15mm

Maximum value of SAR (interpolated) = 0.136 mW/g

**Touch Left - Middle/Zoom Scan (5x5x7) 2 (7x7x7)/Cube 0:** Measurement grid: dx=5mm, dy=5mm, dz=5mm

Reference Value = 4.86 V/m; Power Drift = 0.031 dB

Peak SAR (extrapolated) = 0.166 W/kg

**SAR(1 g) = 0.131 mW/g; SAR(10 g) = 0.095 mW/g**

Maximum value of SAR (measured) = 0.139 mW/g

002: Back of EUT-Body-Worn\_GSM850\_Voice\_CH190

Date: 30/03/2015

DUT: A1428; Sleeve: Linea Pro 5; Sleeve contains FCC ID: YRWDATECSBT301

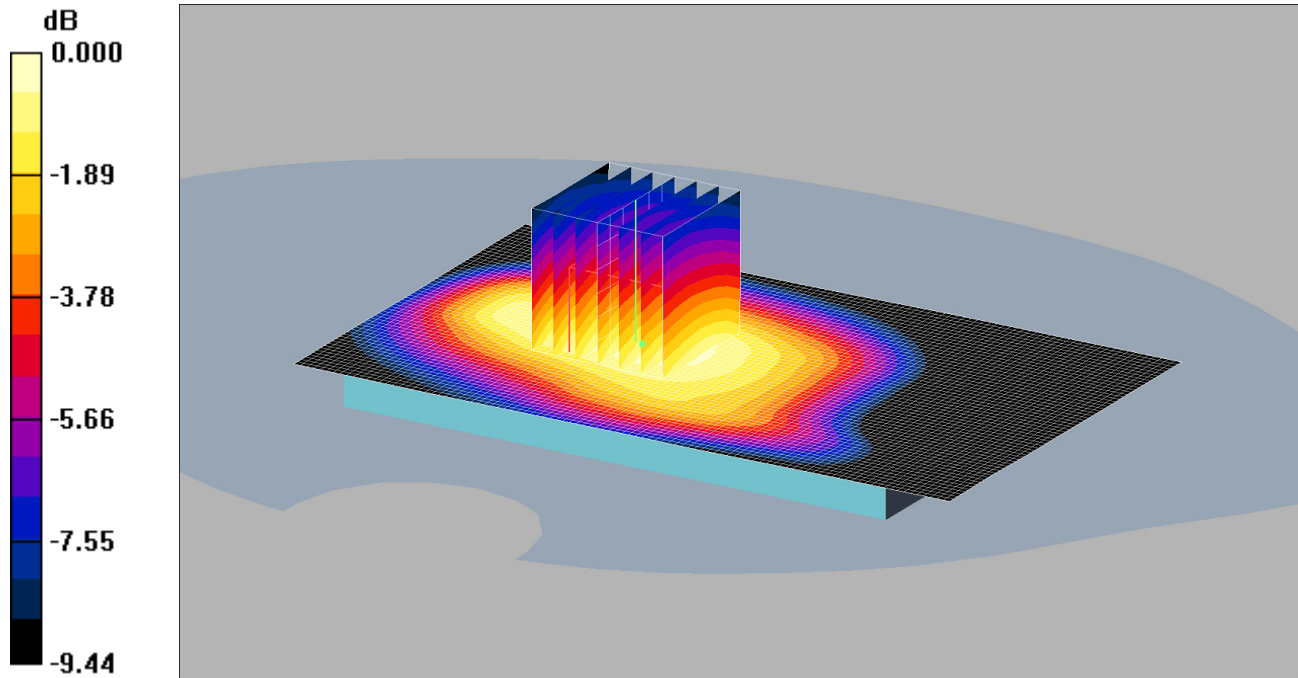

0 dB = 0.108mW/g

Communication System: GSM 850 MHz; Frequency: 836.6 MHz; Duty Cycle: 1:8.3

Medium: 900 MHz MSL Medium parameters used (interpolated): f = 836.6 MHz;  $\sigma = 1$  mho/m;  $\epsilon_r = 53.4$ ;  $\rho = 1000$  kg/m<sup>3</sup>

Phantom section: Flat Section

DASY4 Configuration:

- Probe: ET3DV6 - SN1529; ConvF(6, 6, 6);
- Sensor-Surface: 4mm (Mechanical Surface Detection)
- Electronics: DAE3 Sn394; Calibrated: 16/05/2014
- Phantom: SAM 12a (Site 56); Type: SAM 4.0; Serial: TP:1020
- Measurement SW: DASY4, V4.6 Build 19; Postprocessing SW: SEMCAD, V1.8 Build 159

**Back of EUT Facing Phantom - Middle 2/Area Scan (61x101x1):** Measurement grid: dx=15mm, dy=15mm

Maximum value of SAR (interpolated) = 0.106 mW/g

**Back of EUT Facing Phantom - Middle 2/Zoom Scan (5x5x7) 2 (7x7x7)/Cube 0:** Measurement grid: dx=5mm, dy=5mm, dz=5mm

Reference Value = 10.5 V/m; Power Drift = 0.037 dB

Peak SAR (extrapolated) = 0.133 W/kg

**SAR(1 g) = 0.102 mW/g; SAR(10 g) = 0.073 mW/g**

Maximum value of SAR (measured) = 0.108 mW/g

003: Back of EUT-Hotspot\_GSM850\_GPRS 2Tx\_CH251

Date: 30/03/2015

DUT: A1428; Sleeve: Linea Pro 5; Sleeve contains FCC ID: YRWDATECSBT301

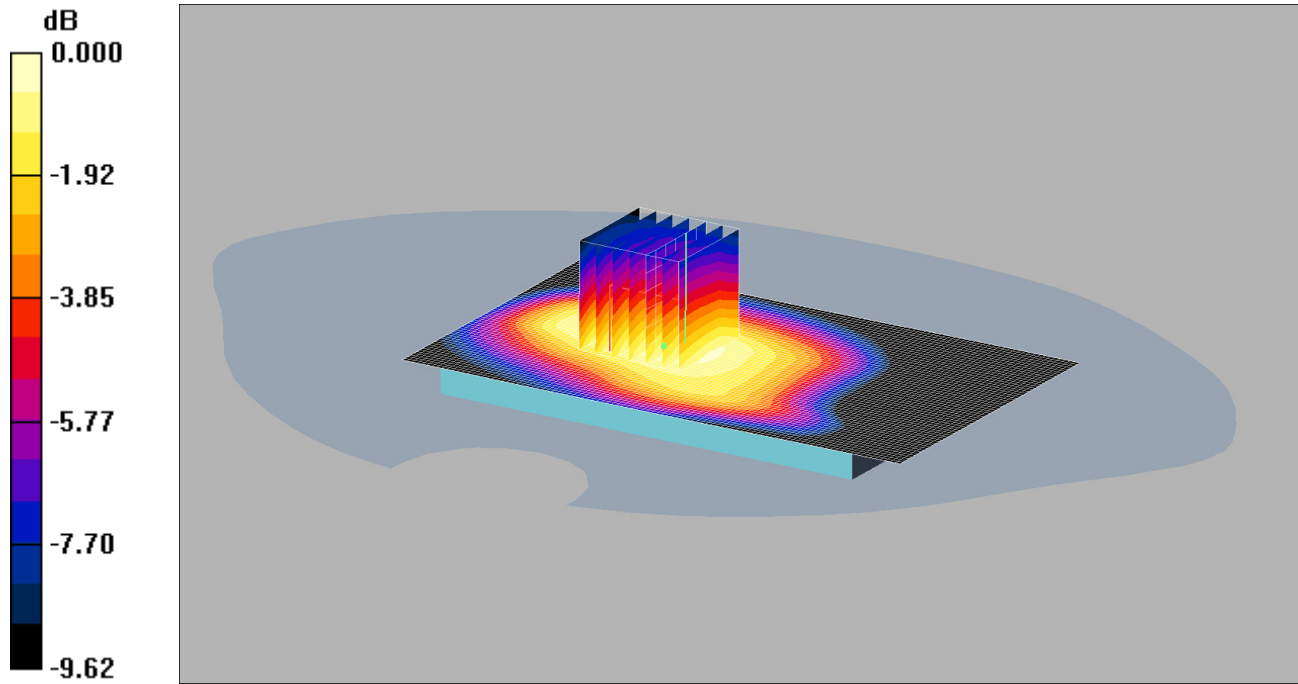

0 dB = 0.131mW/g

Communication System: GPRS 850 MHz 2TX; Frequency: 848.8 MHz; Duty Cycle: 1:4

Medium: 900 MHz MSL Medium parameters used (interpolated):  $f = 848.8$  MHz;  $\sigma = 1.01$  mho/m;  $\epsilon_r = 53.4$ ;  $\rho = 1000$  kg/m<sup>3</sup>

Phantom section: Flat Section

DASY4 Configuration:

- Probe: ET3DV6 - SN1529; ConvF(6, 6, 6);
- Sensor-Surface: 4mm (Mechanical Surface Detection)
- Electronics: DAE3 Sn394; Calibrated: 16/05/2014
- Phantom: SAM 12a (Site 56); Type: SAM 4.0; Serial: TP:1020
- Measurement SW: DASY4, V4.6 Build 19; Postprocessing SW: SEMCAD, V1.8 Build 159

**Back of EUT Facing Phantom - Middle/Area Scan (61x101x1):** Measurement grid: dx=15mm, dy=15mm

Maximum value of SAR (interpolated) = 0.128 mW/g

**Back of EUT Facing Phantom - Middle/Zoom Scan (5x5x7) 2 (7x7x7)/Cube 0:** Measurement grid: dx=5mm, dy=5mm, dz=5mm

Reference Value = 11.5 V/m; Power Drift = -0.004 dB

Peak SAR (extrapolated) = 0.185 W/kg

**SAR(1 g) = 0.123 mW/g; SAR(10 g) = 0.089 mW/g**

Maximum value of SAR (measured) = 0.131 mW/g



004: Touch Right\_PCS1900\_Voice\_CH512

Date: 15/04/2015

DUT: A1428; Sleeve: Linea Pro 5; Sleeve contains FCC ID: YRWDATECSBT301

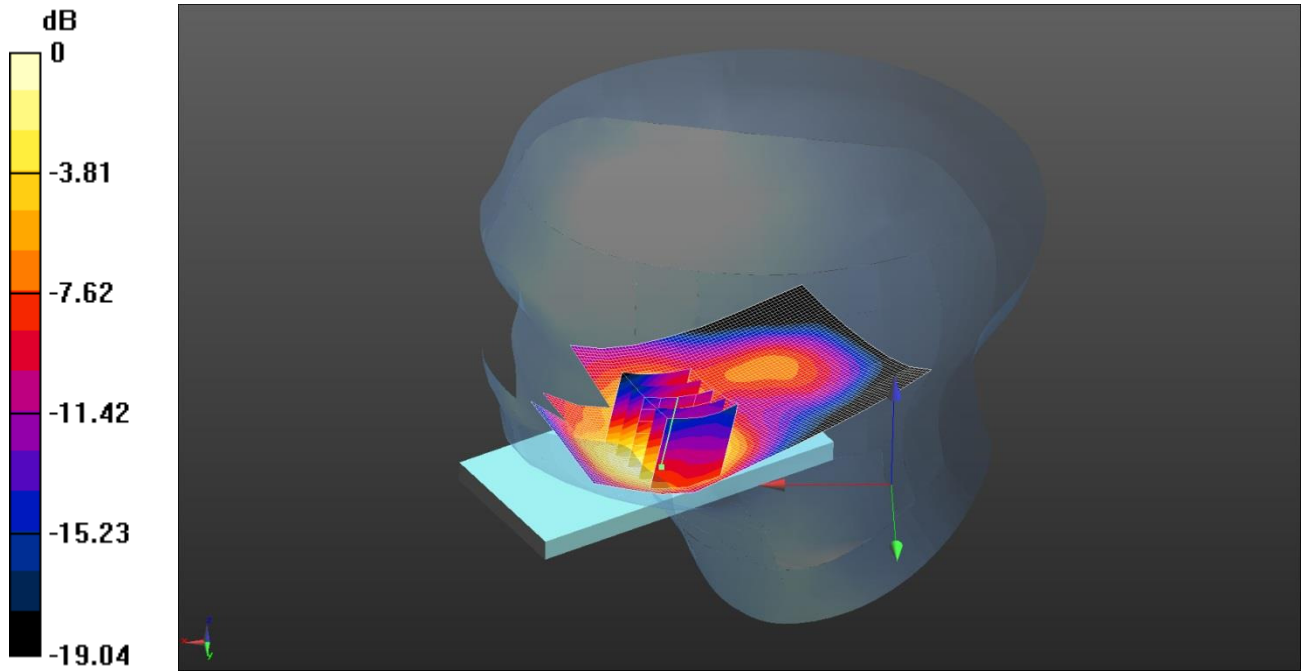

0 dB = 0.251 W/kg = -6.00 dBW/kg

Communication System: UID 0 - n/a, Generic GSM; Frequency: 1850.2 MHz; Duty Cycle: 1:8.30042

Medium: 1900 MHz HSL Medium parameters used (interpolated):  $f = 1850.2$  MHz;  $\sigma = 1.385$  S/m;  $\epsilon_r = 39.26$ ;  $\rho = 1000$  kg/m<sup>3</sup>

Phantom section: Right Section

DASY4 Configuration:

- Probe: ES3DV3 - SN3335; ConvF(5.07, 5.07, 5.07); Calibrated: 29/08/2014;
- Sensor-Surface: 4mm (Mechanical Surface Detection)
- Electronics: DAE3 Sn431; Calibrated: 04/11/2014
- Phantom: SAM B (Site 58); Type: Twin Phantom; Serial: TP:1020
- ; SEMCAD X Version 14.6.9 (7117)

**Configuration/Touch Right- Low/Area Scan 2 (61x101x1):** Interpolated grid: dx=1.500 mm, dy=1.500 mm

Maximum value of SAR (interpolated) = 0.255 W/kg

**Configuration/Touch Right- Low/Zoom Scan (5x5x7) 2 (5x5x7)/Cube 0:** Measurement grid: dx=8mm, dy=8mm, dz=5mm

Reference Value = 5.833 V/m; Power Drift = 0.09 dB

Peak SAR (extrapolated) = 0.360 W/kg

**SAR(1 g) = 0.228 W/kg; SAR(10 g) = 0.134 W/kg**

Maximum value of SAR (measured) = 0.251 W/kg

005: Back of EUT\_Body-Worn\_PCS1900\_Voice\_CH661

Date: 16/04/2015

DUT: A1428; Sleeve: Linea Pro 5; Sleeve contains FCC ID: YRWDATECSBT301

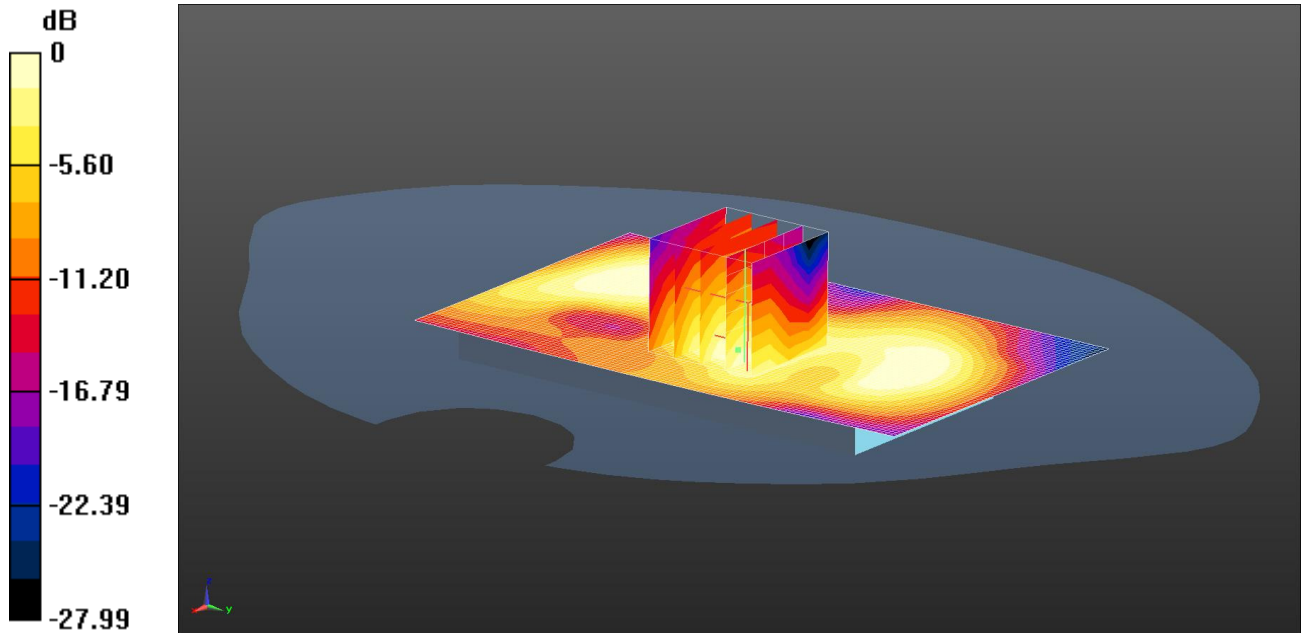

0 dB = 0.287 W/kg = -5.42 dBW/kg

Communication System: UID 0 - n/a, Generic GSM; Frequency: 1880 MHz; Duty Cycle: 1:8.30042

Medium: 1900 MHz MSL Medium parameters used (interpolated):  $f = 1880$  MHz;  $\sigma = 1.557$  S/m;  $\epsilon_r = 54.245$ ;  $\rho = 1000$  kg/m<sup>3</sup>

Phantom section: Flat Section

DASY4 Configuration:

- Probe: ES3DV3 - SN3335; ConvF(4.69, 4.69, 4.69); Calibrated: 29/08/2014;
- Sensor-Surface: 4mm (Mechanical Surface Detection)
- Electronics: DAE3 Sn431; Calibrated: 04/11/2014
- Phantom: SAM A (Site 58); Type: QD000P40Ca; Serial: TP:1193
- ; SEMCAD X Version 14.6.9 (7117)

**Configuration/Back of EUT Facing Phantom - Middle 2/Area Scan (61x101x1):** Interpolated grid: dx=1.500 mm, dy=1.500 mm

Maximum value of SAR (interpolated) = 0.325 W/kg

**Configuration/Back of EUT Facing Phantom - Middle 2/Zoom Scan (5x5x7) 2 (5x5x7)/Cube 0:** Measurement grid:

dx=8mm, dy=8mm, dz=5mm

Reference Value = 9.069 V/m; Power Drift = -0.03 dB

Peak SAR (extrapolated) = 0.482 W/kg

**SAR(1 g) = 0.272 W/kg; SAR(10 g) = 0.146 W/kg**

Maximum value of SAR (measured) = 0.287 W/kg

006: Back of EUT\_Body-Worn\_PCS1900\_GPRS 2Tx\_CH810

Date: 17/04/2015

DUT: A1428; Sleeve: Linea Pro 5; Sleeve contains FCC ID: YRWDATECSBT301

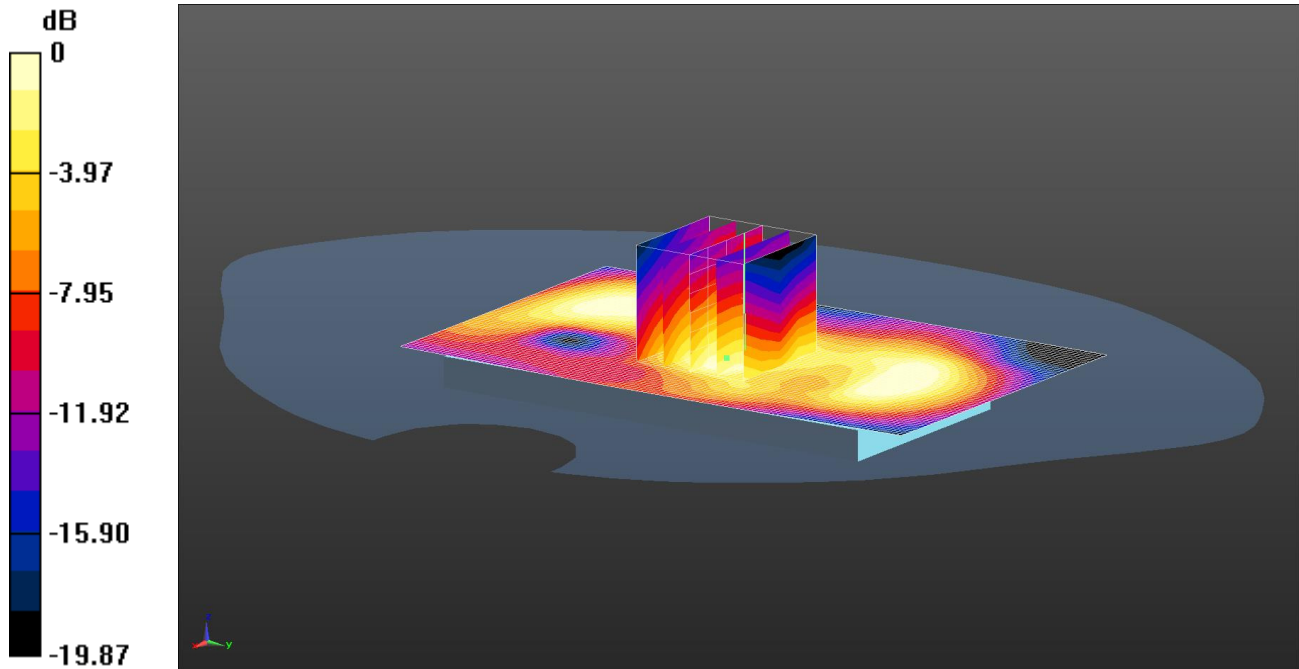

0 dB = 0.308 W/kg = -5.11 dBW/kg

Communication System: UID 0 - n/a, GPRS 2Tx; Frequency: 1909.8 MHz; Duty Cycle: 1:4.00037

Medium: 1900 MHz MSL Medium parameters used (interpolated):  $f = 1909.8$  MHz;  $\sigma = 1.585$  S/m;  $\epsilon_r = 54.123$ ;  $\rho = 1000$  kg/m<sup>3</sup>

Phantom section: Flat Section

DASY4 Configuration:

- Probe: ES3DV3 - SN3335; ConvF(4.69, 4.69, 4.69); Calibrated: 29/08/2014;
- Sensor-Surface: 4mm (Mechanical Surface Detection)
- Electronics: DAE3 Sn431; Calibrated: 04/11/2014
- Phantom: SAM A (Site 58); Type: QD000P40Ca; Serial: TP:1193
- ; SEMCAD X Version 14.6.9 (7117)

**Configuration/Back of EUT Facing Phantom - Middle 2/Area Scan (61x101x1):** Interpolated grid: dx=1.500 mm, dy=1.500 mm

Maximum value of SAR (interpolated) = 0.354 W/kg

**Configuration/Back of EUT Facing Phantom - Middle 2/Zoom Scan (5x5x7) 2 (5x5x7)/Cube 0:** Measurement grid:

dx=8mm, dy=8mm, dz=5mm

Reference Value = 11.198 V/m; Power Drift = 0.02 dB

Peak SAR (extrapolated) = 0.435 W/kg

**SAR(1 g) = 0.286 W/kg; SAR(10 g) = 0.170 W/kg**

Maximum value of SAR (measured) = 0.308 W/kg

007: Touch Right\_UMTS FDD 2\_RMC 12.2kbps\_CH9262

Date: 14/04/2015

DUT: A1428; Sleeve: Linea Pro 5; Sleeve contains FCC ID: YRWDATECSBT301

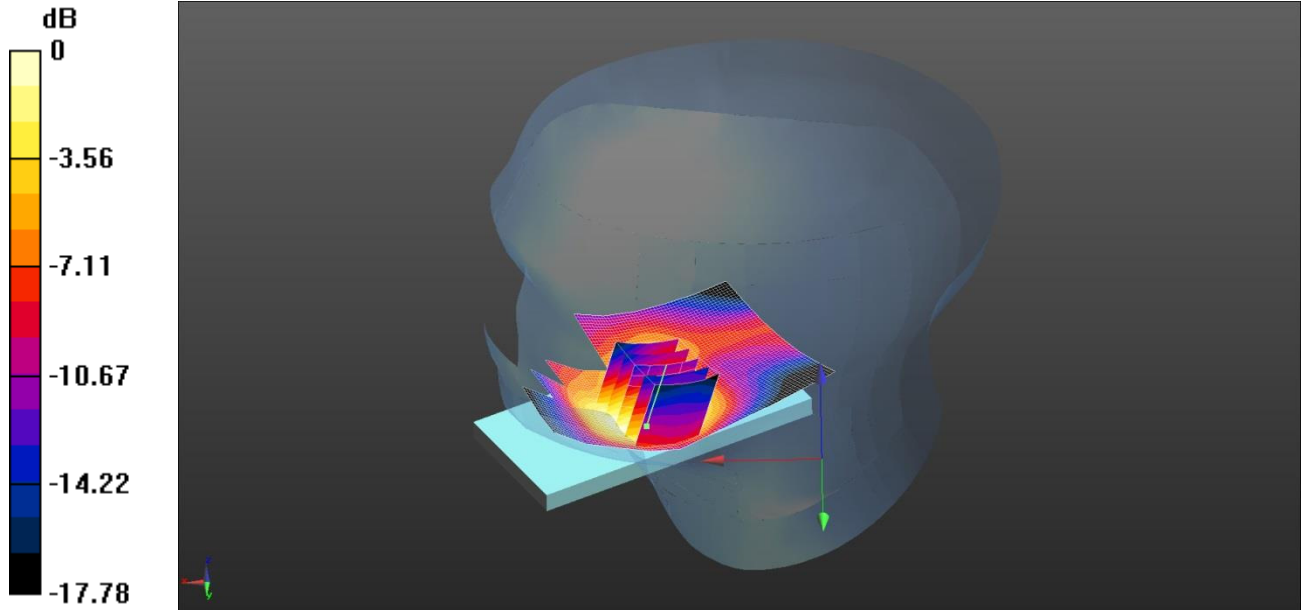

0 dB = 0.230 W/kg = -6.38 dBW/kg

Communication System: UID 0 - n/a, UMTS FDD ; Frequency: 1852.4 MHz; Duty Cycle: 1:1

Medium: 1900 MHz HSL Medium parameters used (interpolated):  $f = 1852.4$  MHz;  $\sigma = 1.387$  S/m;  $\epsilon_r = 39.25$ ;  $\rho = 1000$  kg/m<sup>3</sup>

Phantom section: Right Section

DASY4 Configuration:

- Probe: ES3DV3 - SN3335; ConvF(5.07, 5.07, 5.07); Calibrated: 29/08/2014;
- Sensor-Surface: 4mm (Mechanical Surface Detection)
- Electronics: DAE3 Sn431; Calibrated: 04/11/2014
- Phantom: SAM B (Site 58); Type: Twin Phantom; Serial: TP:1020
- ; SEMCAD X Version 14.6.9 (7117)

**Configuration/Touch Right- Low/Area Scan 2 (61x101x1):** Interpolated grid: dx=1.500 mm, dy=1.500 mm

Maximum value of SAR (interpolated) = 0.255 W/kg

**Configuration/Touch Right- Low/Zoom Scan (5x5x7) 2 (5x5x7)/Cube 0:** Measurement grid: dx=8mm, dy=8mm, dz=5mm

Reference Value = 4.943 V/m; Power Drift = 0.14 dB

Peak SAR (extrapolated) = 0.351 W/kg

**SAR(1 g) = 0.221 W/kg; SAR(10 g) = 0.132 W/kg**

Maximum value of SAR (measured) = 0.230 W/kg

008: Back of EUT\_Body-Worn\_UMTS FDD 2\_RMC 12.2kbps\_CH9400

Date: 17/04/2015

DUT: A1428; Sleeve: Linea Pro 5; Sleeve contains FCC ID: YRWDATECSBT301

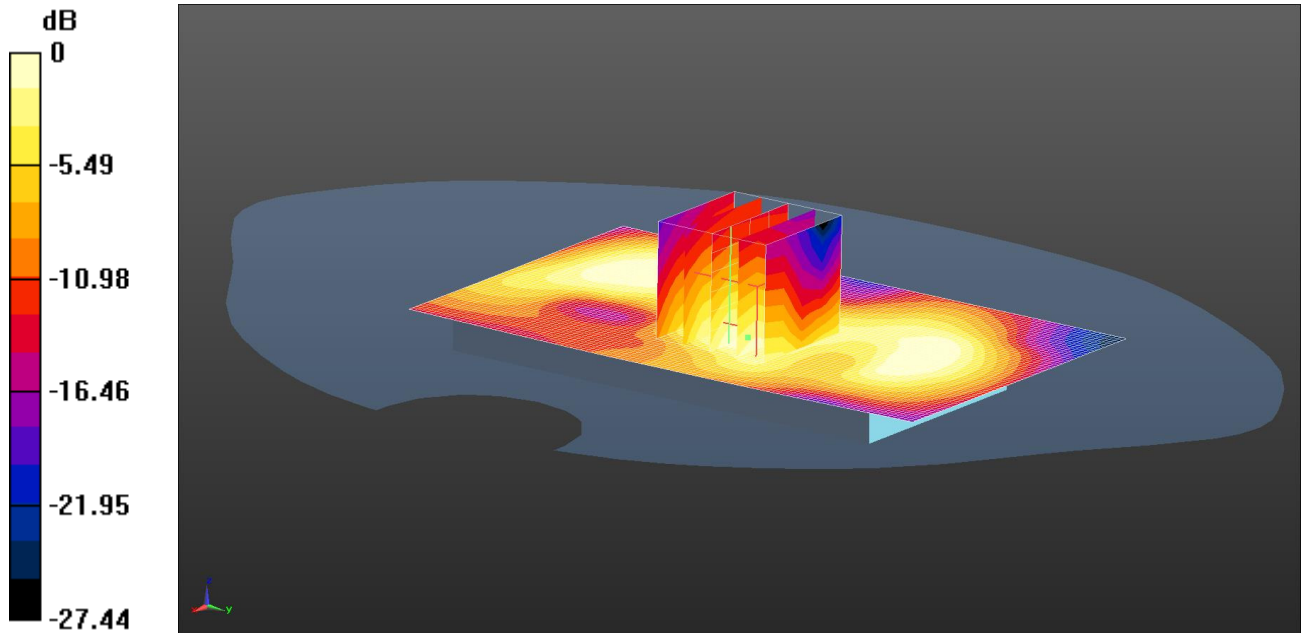

0 dB = 0.442 W/kg = -3.55 dBW/kg

Communication System: UID 0 - n/a, UMTS FDD ; Frequency: 1880 MHz;Duty Cycle: 1:1

Medium: 1900 MHz MSL Medium parameters used (interpolated):  $f = 1880$  MHz;  $\sigma = 1.557$  S/m;  $\epsilon_r = 54.245$ ;  $\rho = 1000$  kg/m<sup>3</sup>

Phantom section: Flat Section

DASY4 Configuration:

- Probe: ES3DV3 - SN3335; ConvF(4.69, 4.69, 4.69); Calibrated: 29/08/2014;
- Sensor-Surface: 4mm (Mechanical Surface Detection)
- Electronics: DAE3 Sn431; Calibrated: 04/11/2014
- Phantom: SAM A (Site 58); Type: QD000P40Ca; Serial: TP:1193
- ; SEMCAD X Version 14.6.9 (7117)

**Configuration/Back of EUT Facing Phantom - Middle 2/Area Scan (61x101x1):** Interpolated grid: dx=1.500 mm, dy=1.500 mm

Maximum value of SAR (interpolated) = 0.487 W/kg

**Configuration/Back of EUT Facing Phantom - Middle 2/Zoom Scan (5x5x7) 2 (5x5x7)/Cube 0:** Measurement grid:

dx=8mm, dy=8mm, dz=5mm

Reference Value = 11.264 V/m; Power Drift = -0.01 dB

Peak SAR (extrapolated) = 0.697 W/kg

**SAR(1 g) = 0.398 W/kg; SAR(10 g) = 0.216 W/kg**

Maximum value of SAR (measured) = 0.442 W/kg

009: Touch Right\_UMTS FDD 4\_RMC 12.2kbps\_CH1413

Date: 13/04/2015

DUT: A1428; Sleeve: Linea Pro 5; Sleeve contains FCC ID: YRWDTECSBT301

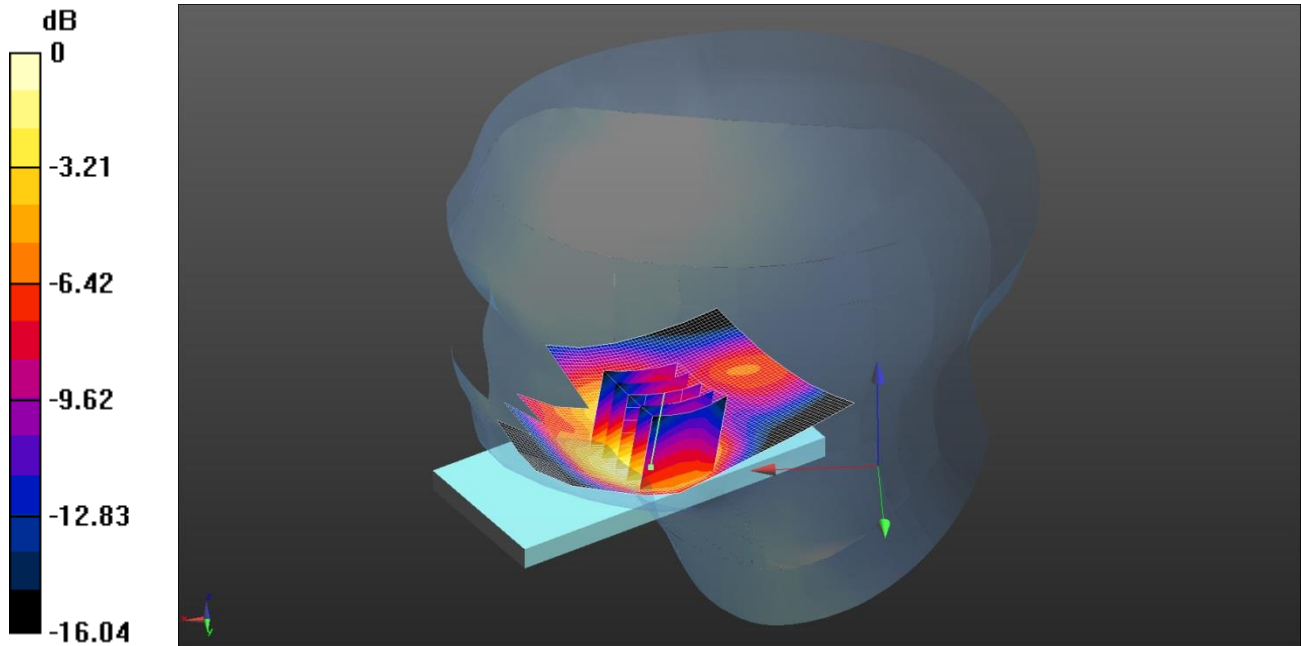

0 dB = 0.408 W/kg = -3.89 dBW/kg

Communication System: UID 0 - n/a, UMTS FDD ; Frequency: 1732.6 MHz;Duty Cycle: 1:1

Medium: 1800 MHz HSL Medium parameters used (interpolated): f = 1732.6 MHz;  $\sigma = 1.312$  S/m;  $\epsilon_r = 40.141$ ;  $\rho = 1000$  kg/m<sup>3</sup>

Phantom section: Right Section

DASY4 Configuration:

- Probe: ES3DV3 - SN3335; ConvF(5.21, 5.21, 5.21); Calibrated: 29/08/2014;
- Sensor-Surface: 4mm (Mechanical Surface Detection)
- Electronics: DAE3 Sn431; Calibrated: 04/11/2014
- Phantom: SAM B (Site 58); Type: Twin Phantom; Serial: TP:1020
- ; SEMCAD X Version 14.6.9 (7117)

**Configuration/Touch Right- Low/Area Scan 2 (61x101x1):** Interpolated grid: dx=1.500 mm, dy=1.500 mm

Maximum value of SAR (interpolated) = 0.419 W/kg

**Configuration/Touch Right- Low/Zoom Scan (5x5x7) 2 (5x5x7)/Cube 0:** Measurement grid: dx=8mm, dy=8mm, dz=5mm

Reference Value = 7.820 V/m; Power Drift = 0.04 dB

Peak SAR (extrapolated) = 0.551 W/kg

**SAR(1 g) = 0.380 W/kg; SAR(10 g) = 0.239 W/kg**

Maximum value of SAR (measured) = 0.408 W/kg

010: Front of EUT-Body-Worn\_UMTS FDD 4\_RMC 12.2kbps\_CH1413

Date: 13/04/2015

DUT: A1428; Sleeve: Linea Pro 5; Sleeve contains FCC ID: YRWDATCSBT301

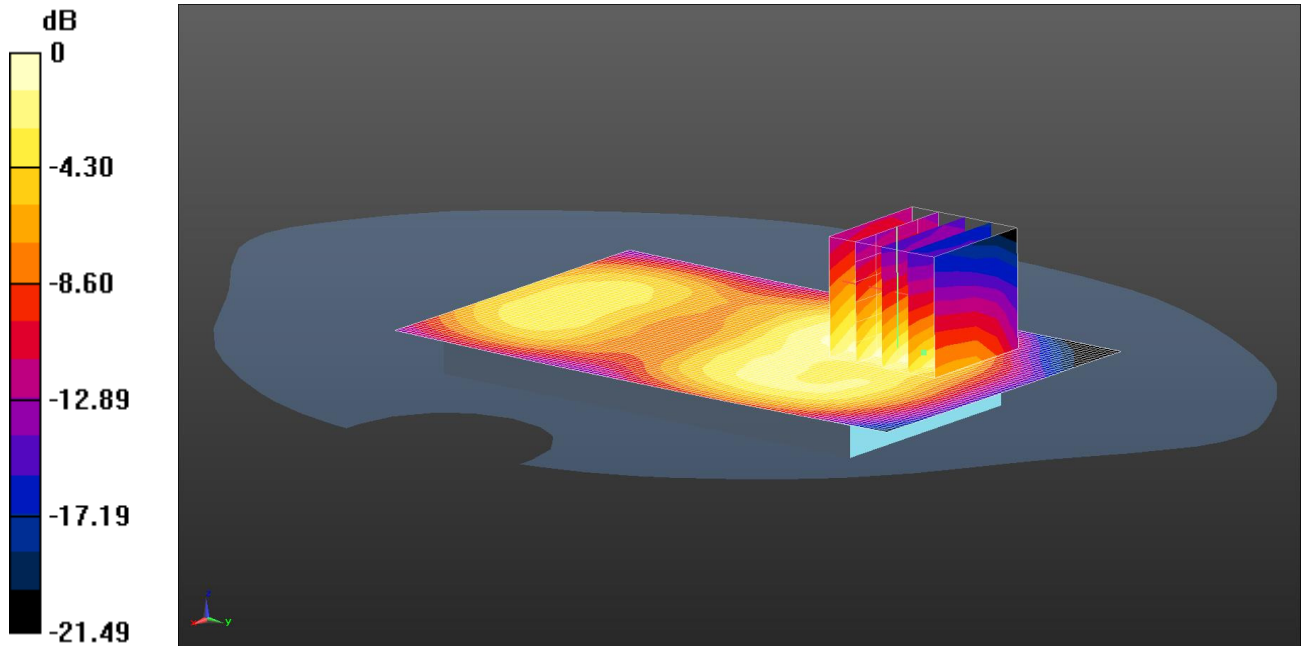

0 dB = 0.304 W/kg = -5.17 dBW/kg

Communication System: UID 0 - n/a, UMTS-FDD IV; Frequency: 1732.6 MHz; Duty Cycle: 1:1

Medium: 1800 MHz MSL Medium parameters used (interpolated):  $f = 1732.6$  MHz;  $\sigma = 1.487$  S/m;  $\epsilon_r = 52.149$ ;  $\rho = 1000$  kg/m<sup>3</sup>

Phantom section: Flat Section

DASY4 Configuration:

- Probe: ES3DV3 - SN3335; ConvF(4.91, 4.91, 4.91); Calibrated: 29/08/2014;
- Sensor-Surface: 4mm (Mechanical Surface Detection)
- Electronics: DAE3 Sn431; Calibrated: 04/11/2014
- Phantom: SAM A (Site 58); Type: QD000P40Ca; Serial: TP:1193
- ; SEMCAD X Version 14.6.9 (7117)

**SAR/Front of the EUT Facing the Phantom - Middle/Area Scan (61x101x1):** Interpolated grid: dx=1.500 mm, dy=1.500 mm

Maximum value of SAR (interpolated) = 0.318 W/kg

**SAR/Front of the EUT Facing the Phantom - Middle/Zoom Scan (5x5x7) 2 (5x5x7)/Cube 0:** Measurement grid:

dx=8mm, dy=8mm, dz=5mm

Reference Value = 6.153 V/m; Power Drift = 0.09 dB

Peak SAR (extrapolated) = 0.505 W/kg

**SAR(1 g) = 0.283 W/kg; SAR(10 g) = 0.165 W/kg**

Maximum value of SAR (measured) = 0.304 W/kg

011: Touch Left\_UMTS FDD 5\_RMC 12.2kbps\_CH4233

Date: 31/03/2015

DUT: A1428; Sleeve: Linea Pro 5; Sleeve contains FCC ID: YRWDTECSBT301

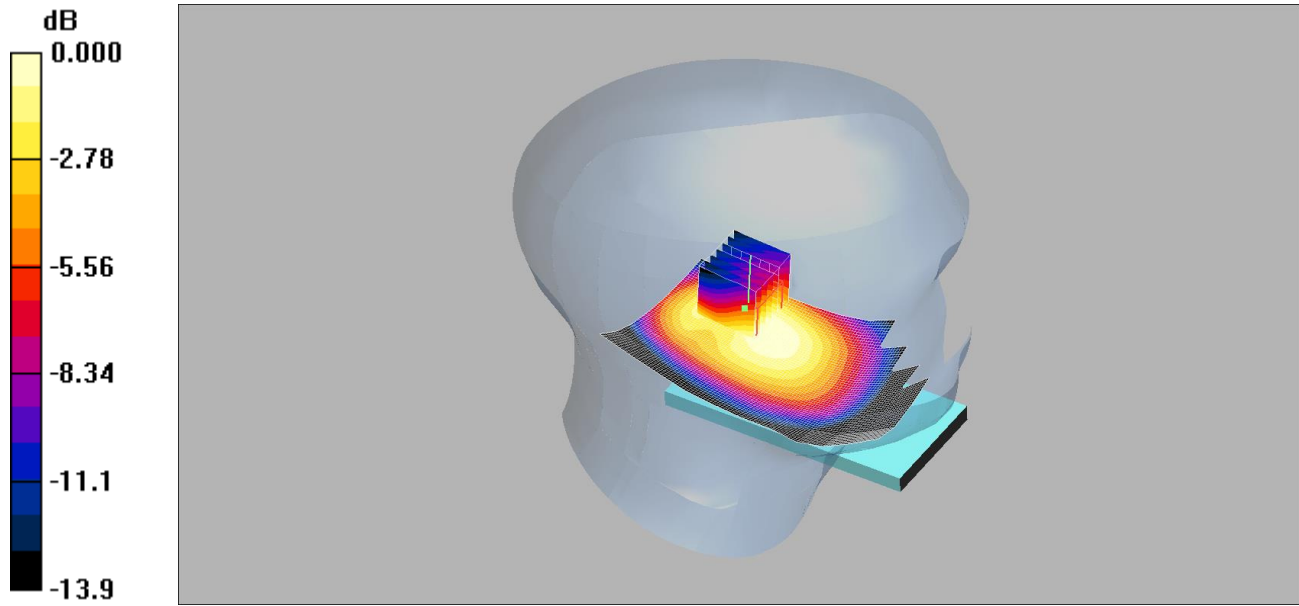

0 dB = 0.660mW/g

Communication System: UMTS-FDD 5; Frequency: 846.6 MHz; Duty Cycle: 1:1

Medium: 900 MHz HSL Medium parameters used (interpolated):  $f = 846.6$  MHz;  $\sigma = 0.896$  mho/m;  $\epsilon_r = 41.3$ ;  $\rho = 1000$  kg/m<sup>3</sup>

Phantom section: Left Section

DASY4 Configuration:

- Probe: ET3DV6 - SN1529; ConvF(6.28, 6.28, 6.28);
- Sensor-Surface: 4mm (Mechanical Surface Detection)
- Electronics: DAE3 Sn394; Calibrated: 16/05/2014
- Phantom: SAM 12b (Site 56); Type: SAM 4.0; Serial: TP:1192
- Measurement SW: DASY4, V4.6 Build 19; Postprocessing SW: SEMCAD, V1.8 Build 159

**Touch Left - Middle/Area Scan (61x101x1):** Measurement grid: dx=15mm, dy=15mm

Maximum value of SAR (interpolated) = 0.665 mW/g

**Touch Left - Middle/Zoom Scan (5x5x7) 2 (7x7x7)/Cube 0:** Measurement grid: dx=5mm, dy=5mm, dz=5mm

Reference Value = 19.6 V/m; Power Drift = -0.023 dB

Peak SAR (extrapolated) = 1.11 W/kg

**SAR(1 g) = 0.591 mW/g; SAR(10 g) = 0.376 mW/g**

Maximum value of SAR (measured) = 0.660 mW/g



012: Back of EUT-Body-Worn\_UMTS FDD 5\_RMC 12.2kbps\_CH4233

Date: 01/04/2015

DUT: A1428; Sleeve: Linea Pro 5; Sleeve contains FCC ID: YRWDATECSBT301

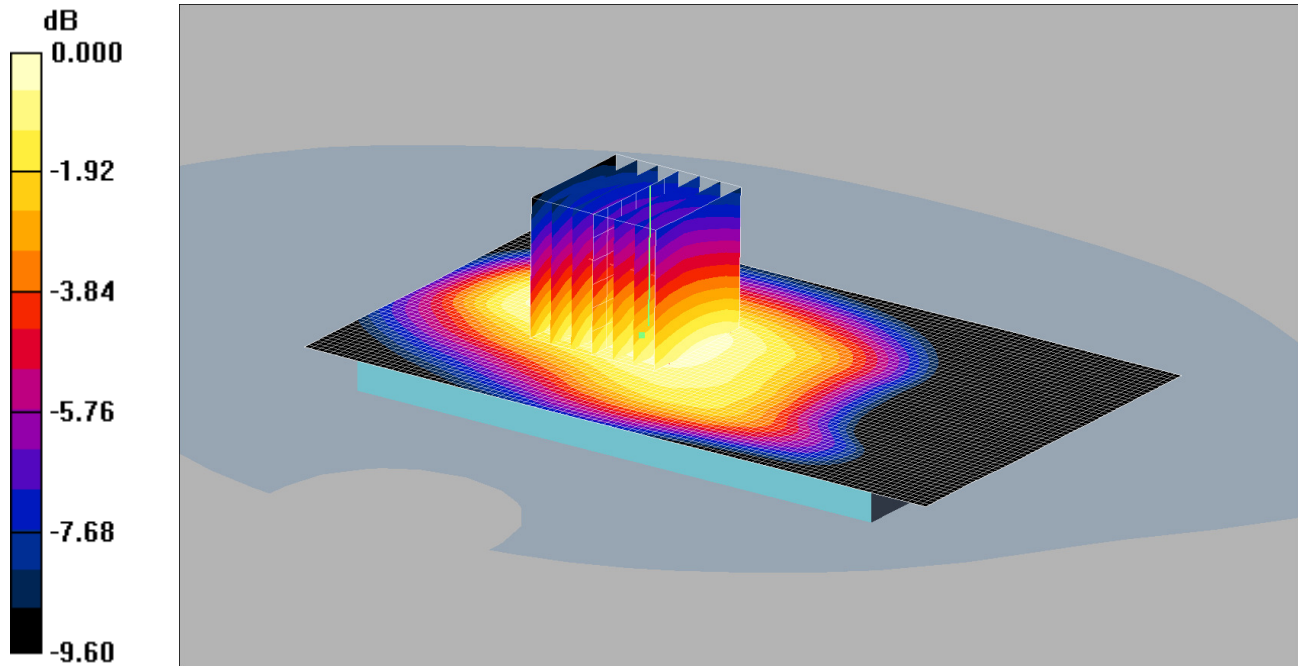

0 dB = 0.101mW/g

Communication System: UMTS-FDD 5; Frequency: 846.6 MHz; Duty Cycle: 1:1

Medium: 900 MHz MSL Medium parameters used (interpolated):  $f = 846.6$  MHz;  $\sigma = 1.01$  mho/m;  $\epsilon_r = 53.4$ ;  $\rho = 1000$  kg/m<sup>3</sup>

Phantom section: Flat Section

DASY4 Configuration:

- Probe: ET3DV6 - SN1529; ConvF(6, 6, 6);
- Sensor-Surface: 4mm (Mechanical Surface Detection)
- Electronics: DAE3 Sn394; Calibrated: 16/05/2014
- Phantom: SAM 12a (Site 56); Type: SAM 4.0; Serial: TP:1020
- Measurement SW: DASY4, V4.6 Build 19; Postprocessing SW: SEMCAD, V1.8 Build 159

**Back of EUT Facing Phantom - Middle/Area Scan (61x101x1):** Measurement grid: dx=15mm, dy=15mm

Maximum value of SAR (interpolated) = 0.101 mW/g

**Back of EUT Facing Phantom - Middle/Zoom Scan (5x5x7) 2 (7x7x7)/Cube 0:** Measurement grid: dx=5mm, dy=5mm, dz=5mm

Reference Value = 10.5 V/m; Power Drift = -0.010 dB

Peak SAR (extrapolated) = 0.124 W/kg

**SAR(1 g) = 0.096 mW/g; SAR(10 g) = 0.069 mW/g**

Maximum value of SAR (measured) = 0.101 mW/g

Note: SAR level measured is very low as equivalent to noise floor.

013: Back of EUT\_Body-Worn\_LTE FDD 2\_20MHz 1RB Mid\_CH18900

Date: 17/04/2015

DUT: A1428; Sleeve: Linea Pro 5; Sleeve contains FCC ID: YRWDATECSBT301

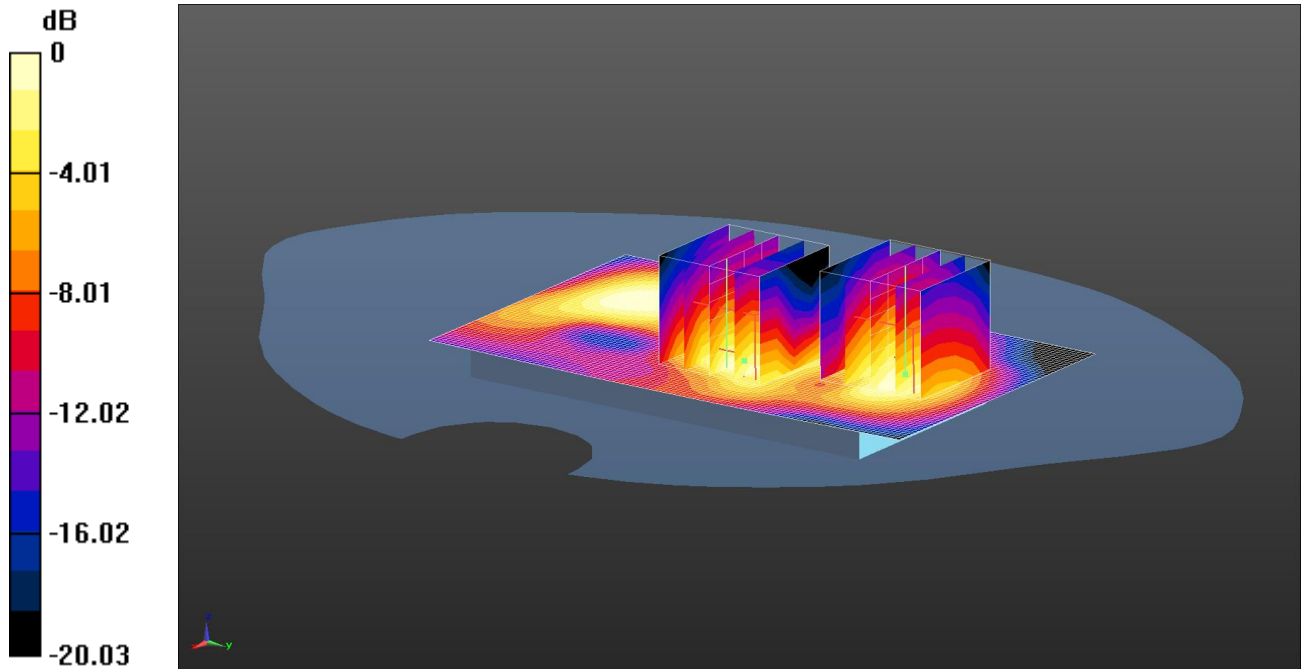

0 dB = 0.529 W/kg = -2.77 dBW/kg

Communication System: UID 0 - n/a, LTE FDD Bands - 20MHz Channel BW ; Frequency: 1880 MHz;Duty Cycle: 1:1  
 Medium: 1900 MHz MSL Medium parameters used (interpolated): f = 1880 MHz;  $\sigma = 1.557$  S/m;  $\epsilon_r = 54.245$ ;  $\rho = 1000$  kg/m<sup>3</sup>  
 Phantom section: Flat Section

DASY4 Configuration:

- Probe: ES3DV3 - SN3335; ConvF(4.69, 4.69, 4.69); Calibrated: 29/08/2014;
- Sensor-Surface: 4mm (Mechanical Surface Detection)
- Electronics: DAE3 Sn431; Calibrated: 04/11/2014
- Phantom: SAM A (Site 58); Type: QD000P40Ca; Serial: TP:1193
- ; SEMCAD X Version 14.6.9 (7117)

**Configuration/Back of EUT Facing Phantom - Middle 2/Area Scan (61x101x1):** Interpolated grid: dx=1.500 mm, dy=1.500 mm

Maximum value of SAR (interpolated) = 0.558 W/kg

**Configuration/Back of EUT Facing Phantom - Middle 2/Zoom Scan (5x5x7) 2 (5x5x7)/Cube 0:** Measurement grid: dx=8mm, dy=8mm, dz=5mm

Reference Value = 11.823 V/m; Power Drift = 0.08 dB

Peak SAR (extrapolated) = 0.836 W/kg

**SAR(1 g) = 0.469 W/kg; SAR(10 g) = 0.251 W/kg**

Maximum value of SAR (measured) = 0.515 W/kg

**Configuration/Back of EUT Facing Phantom - Middle 2/Zoom Scan (5x5x7) 2 (5x5x7)/Cube 1:** Measurement grid: dx=8mm, dy=8mm, dz=5mm

Reference Value = 11.823 V/m; Power Drift = 0.08 dB

Peak SAR (extrapolated) = 0.770 W/kg

**SAR(1 g) = 0.486 W/kg; SAR(10 g) = 0.271 W/kg**

Maximum value of SAR (measured) = 0.529 W/kg

Note: DASY system is configured to measure any secondary maxima that are within 2dB of the measured SAR level.

014: Touch Right\_LTE FDD 4\_20MHz 1RB High\_CH20050

Date: 13/04/2015

DUT: A1428; Sleeve: Linea Pro 5; Sleeve contains FCC ID: YRWDATECSBT301

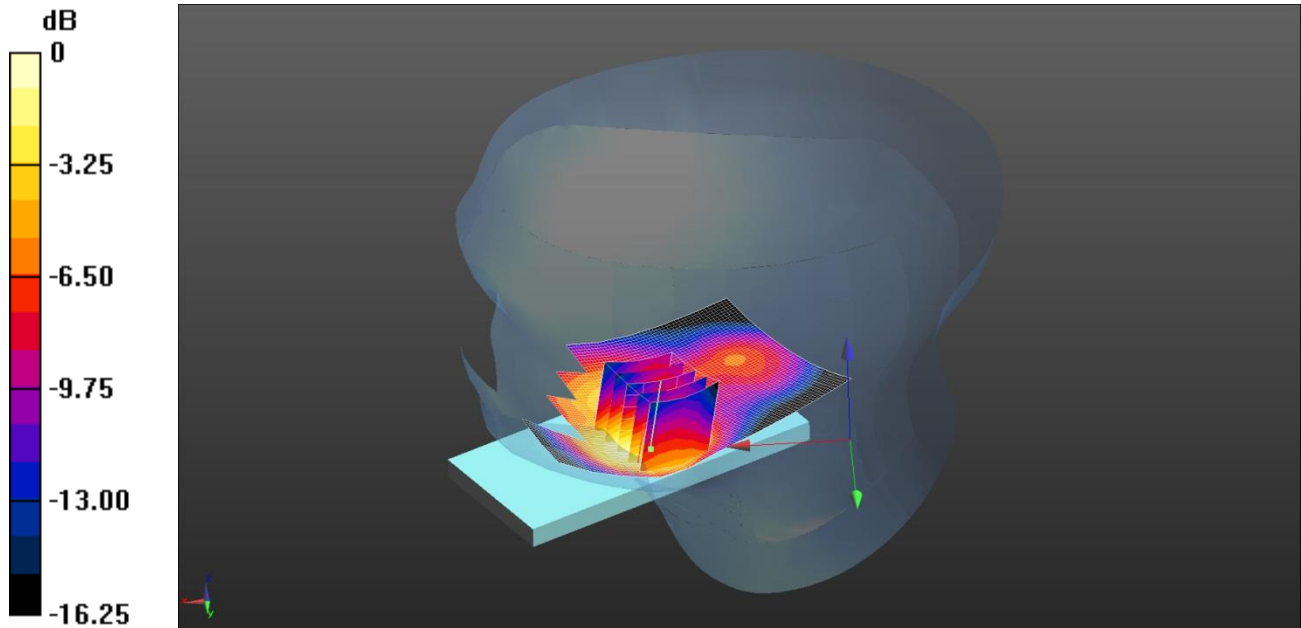

0 dB = 0.438 W/kg = -3.59 dBW/kg

Communication System: UID 0 - n/a, LTE - Band 4 / 20MHz Channel; Frequency: 1720 MHz; Duty Cycle: 1:1  
 Medium: 1800 MHz HSL Medium parameters used (interpolated):  $f = 1720$  MHz;  $\sigma = 1.299$  S/m;  $\epsilon_r = 40.191$ ;  $\rho = 1000$  kg/m<sup>3</sup>  
 Phantom section: Right Section  
 DASY4 Configuration:  
 - Probe: ES3DV3 - SN3335; ConvF(5.21, 5.21, 5.21); Calibrated: 29/08/2014;  
 - Sensor-Surface: 4mm (Mechanical Surface Detection)  
 - Electronics: DAE3 Sn431; Calibrated: 04/11/2014  
 - Phantom: SAM B (Site 58); Type: Twin Phantom; Serial: TP:1020  
 - ; SEMCAD X Version 14.6.9 (7117)

**Configuration/Touch Right- Low/Area Scan (61x101x1):** Interpolated grid: dx=1.500 mm, dy=1.500 mm

Maximum value of SAR (interpolated) = 0.441 W/kg

**Configuration/Touch Right- Low/Zoom Scan (5x5x7) 2 (5x5x7)/Cube 0:** Measurement grid: dx=8mm, dy=8mm, dz=5mm

Reference Value = 7.871 V/m; Power Drift = 0.03 dB

Peak SAR (extrapolated) = 0.590 W/kg

**SAR(1 g) = 0.401 W/kg; SAR(10 g) = 0.252 W/kg**

Maximum value of SAR (measured) = 0.438 W/kg

015: Touch Right\_LTE FDD 4\_20MHz 1RB High\_CH20300

Date: 13/04/2015

DUT: A1428; Sleeve: Linea Pro 5; Sleeve contains FCC ID: YRWDATCSBT301

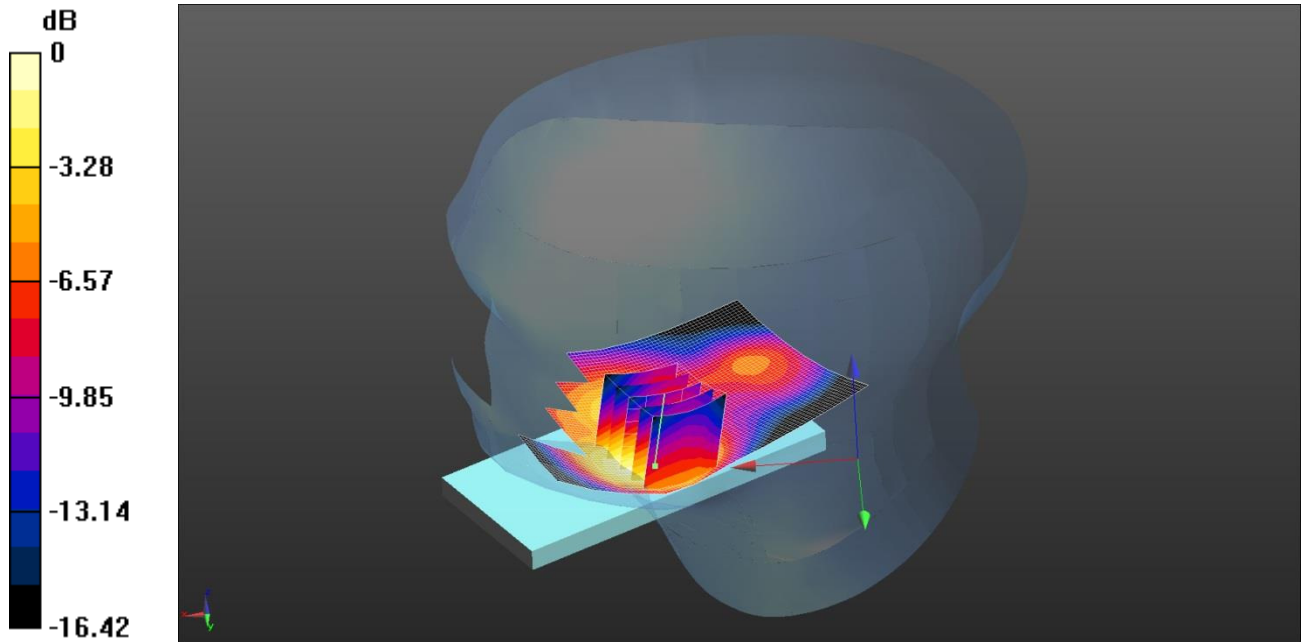

0 dB = 0.403 W/kg = -3.95 dBW/kg

Communication System: UID 0 - n/a, LTE FDD Bands - 20MHz Channel BW ; Frequency: 1745 MHz;Duty Cycle: 1:1  
 Medium: 1800 MHz HSL Medium parameters used (interpolated): f = 1745 MHz;  $\sigma = 1.326$  S/m;  $\epsilon_r = 40.091$ ;  $\rho = 1000$  kg/m<sup>3</sup>  
 Phantom section: Right Section

DASY4 Configuration:

- Probe: ES3DV3 - SN3335; ConvF(5.21, 5.21, 5.21); Calibrated: 29/08/2014;
- Sensor-Surface: 4mm (Mechanical Surface Detection)
- Electronics: DAE3 Sn431; Calibrated: 04/11/2014
- Phantom: SAM B (Site 58); Type: Twin Phantom; Serial: TP:1020
- ; SEMCAD X Version 14.6.9 (7117)

**Configuration/Touch Right- Low/Area Scan (61x101x1):** Interpolated grid: dx=1.500 mm, dy=1.500 mm

Maximum value of SAR (interpolated) = 0.407 W/kg

**Configuration/Touch Right- Low/Zoom Scan (5x5x7) 2 (5x5x7)/Cube 0:** Measurement grid: dx=8mm, dy=8mm, dz=5mm

Reference Value = 7.811 V/m; Power Drift = 0.07 dB

Peak SAR (extrapolated) = 0.551 W/kg

**SAR(1 g) = 0.371 W/kg; SAR(10 g) = 0.232 W/kg**

Maximum value of SAR (measured) = 0.403 W/kg

016: Touch Right\_LTE FDD 4\_20MHz 1RB Low\_CH20050

Date: 13/04/2015

DUT: A1428; Sleeve: Linea Pro 5; Sleeve contains FCC ID: YRWDATECSBT301

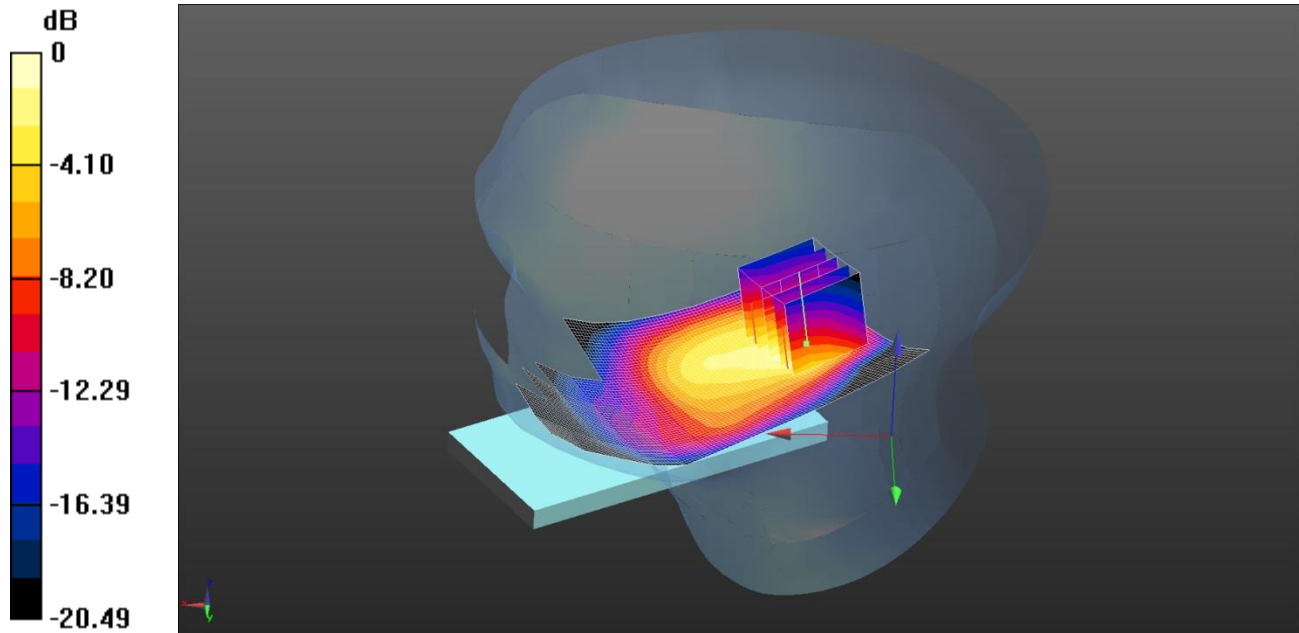

0 dB = 0.643 W/kg = -1.92 dBW/kg

Communication System: UID 0 - n/a, LTE - Band 4 / 20MHz Channel; Frequency: 1720 MHz; Duty Cycle: 1:1  
 Medium: 1800 MHz HSL Medium parameters used (interpolated):  $f = 1720$  MHz;  $\sigma = 1.299$  S/m;  $\epsilon_r = 40.191$ ;  $\rho = 1000$  kg/m<sup>3</sup>

Phantom section: Right Section

DASY4 Configuration:

- Probe: ES3DV3 - SN3335; ConvF(5.21, 5.21, 5.21); Calibrated: 29/08/2014;
- Sensor-Surface: 4mm (Mechanical Surface Detection)
- Electronics: DAE3 Sn431; Calibrated: 04/11/2014
- Phantom: SAM B (Site 58); Type: Twin Phantom; Serial: TP:1020
- ; SEMCAD X Version 14.6.9 (7117)

**Configuration/Touch Right- Low/Area Scan 2 (61x111x1):** Interpolated grid: dx=1.500 mm, dy=1.500 mm

Maximum value of SAR (interpolated) = 0.618 W/kg

**Configuration/Touch Right- Low/Zoom Scan (5x5x7) 2 (5x5x7)/Cube 0:** Measurement grid: dx=8mm, dy=8mm, dz=5mm

Reference Value = 21.877 V/m; Power Drift = -0.05 dB

Peak SAR (extrapolated) = 1.02 W/kg

**SAR(1 g) = 0.573 W/kg; SAR(10 g) = 0.306 W/kg**

Maximum value of SAR (measured) = 0.643 W/kg

017: Touch Right\_LTE FDD 4\_20MHz 1RB Mid\_CH20300

Date: 13/04/2015

DUT: A1428; Sleeve: Linea Pro 5; Sleeve contains FCC ID: YRWDATECSBT301

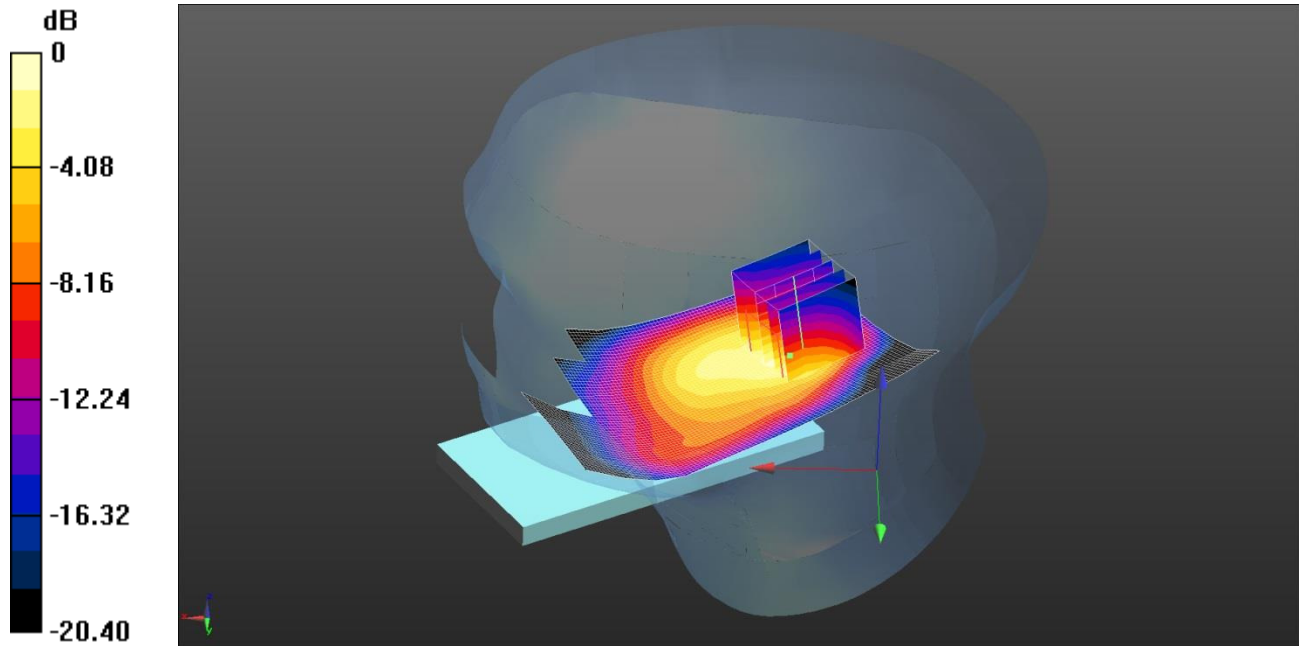

0 dB = 0.531 W/kg = -2.75 dBW/kg

Communication System: UID 0 - n/a, LTE FDD Bands - 20MHz Channel BW ; Frequency: 1745 MHz; Duty Cycle: 1:1  
 Medium: 1800 MHz HSL Medium parameters used (interpolated): f = 1745 MHz;  $\sigma = 1.326$  S/m;  $\epsilon_r = 40.091$ ;  $\rho = 1000$  kg/m<sup>3</sup>  
 Phantom section: Right Section

DASY4 Configuration:

- Probe: ES3DV3 - SN3335; ConvF(5.21, 5.21, 5.21); Calibrated: 29/08/2014;
- Sensor-Surface: 4mm (Mechanical Surface Detection)
- Electronics: DAE3 Sn431; Calibrated: 04/11/2014
- Phantom: SAM B (Site 58); Type: Twin Phantom; Serial: TP:1020
- ; SEMCAD X Version 14.6.9 (7117)

**Configuration/Touch Right- Low/Area Scan 2 (61x101x1):** Interpolated grid: dx=1.500 mm, dy=1.500 mm

Maximum value of SAR (interpolated) = 0.545 W/kg

**Configuration/Touch Right- Low/Zoom Scan (5x5x7) 2 (5x5x7)/Cube 0:** Measurement grid: dx=8mm, dy=8mm, dz=5mm

Reference Value = 19.715 V/m; Power Drift = -0.03 dB

Peak SAR (extrapolated) = 0.837 W/kg

**SAR(1 g) = 0.463 W/kg; SAR(10 g) = 0.248 W/kg**

Maximum value of SAR (measured) = 0.531 W/kg

018: Back of EUT-Body-Worn\_LTE FDD 4\_20MHz 1RB Mid\_CH20175

Date: 14/04/2015

DUT: A1428; Sleeve: Linea Pro 5; Sleeve contains FCC ID: YRWDATECSBT301

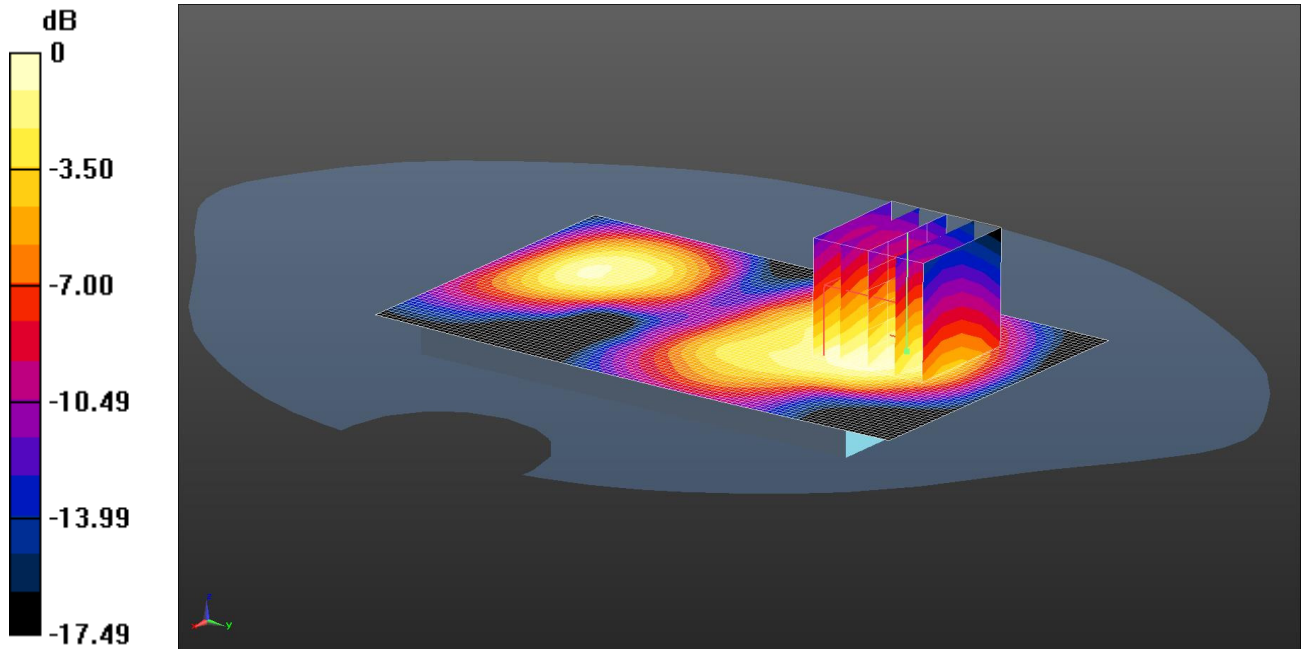

0 dB = 0.479 W/kg = -3.20 dBW/kg

Communication System: UID 0 - n/a, LTE FDD Bands - 20MHz Channel BW ; Frequency: 1732.5 MHz; Duty Cycle: 1:1  
 Medium: 1800 MHz MSL Medium parameters used (interpolated): f = 1732.5 MHz;  $\sigma = 1.487$  S/m;  $\epsilon_r = 52.149$ ;  $\rho = 1000$  kg/m<sup>3</sup>

Phantom section: Flat Section

DASY4 Configuration:

- Probe: ES3DV3 - SN3335; ConvF(4.91, 4.91, 4.91); Calibrated: 29/08/2014;
- Sensor-Surface: 4mm (Mechanical Surface Detection)
- Electronics: DAE3 Sn431; Calibrated: 04/11/2014
- Phantom: SAM A (Site 58); Type: QD000P40Ca; Serial: TP:1193
- ; SEMCAD X Version 14.6.9 (7117)

**SAR/Back of the EUT Facing the Phantom - Middle/Area Scan (61x101x1):** Interpolated grid: dx=1.500 mm, dy=1.500 mm

Maximum value of SAR (interpolated) = 0.532 W/kg

**SAR/Back of the EUT Facing the Phantom - Middle/Zoom Scan (5x5x7) 2 (5x5x7)/Cube 0:** Measurement grid: dx=8mm, dy=8mm, dz=5mm

Reference Value = 4.817 V/m; Power Drift = 0.00 dB

Peak SAR (extrapolated) = 0.658 W/kg

**SAR(1 g) = 0.443 W/kg; SAR(10 g) = 0.282 W/kg**

Maximum value of SAR (measured) = 0.479 W/kg

019: Front of EUT-Body-Worn\_LTE FDD 5\_10MHz 1RB Mid\_CH20525

Date: 08/04/2015

DUT: A1428; Sleeve: Linea Pro 5; Sleeve contains FCC ID: YRWDATECSBT301

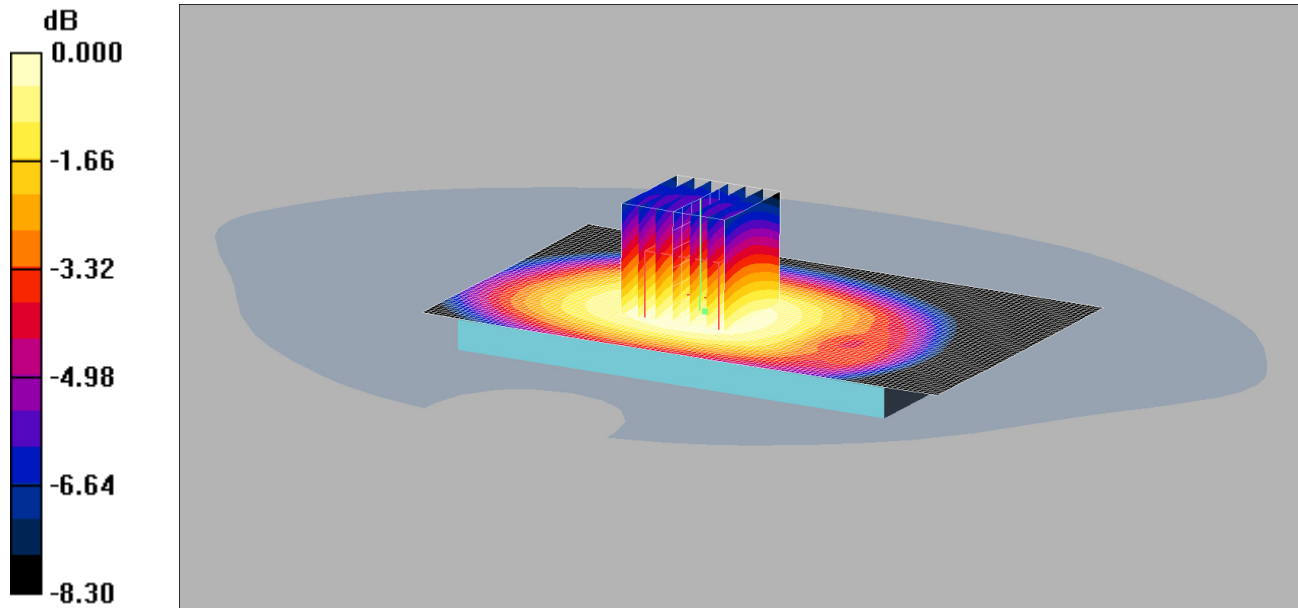

0 dB = 0.227mW/g

Communication System: LTE Band 5 / 10MHz; Frequency: 836.5 MHz; Duty Cycle: 1:1

Medium: 900 MHz MSL Medium parameters used (interpolated): f = 836.5 MHz;  $\sigma = 1.02$  mho/m;  $\epsilon_r = 53.7$ ;  $\rho = 1000$  kg/m<sup>3</sup>

Phantom section: Flat Section

DASY4 Configuration:

- Probe: ET3DV6 - SN1529; ConvF(6, 6, 6);
- Sensor-Surface: 4mm (Mechanical Surface Detection)
- Electronics: DAE3 Sn394; Calibrated: 16/05/2014
- Phantom: SAM 12a (Site 56); Type: SAM 4.0; Serial: TP:1020
- Measurement SW: DASY4, V4.6 Build 19; Postprocessing SW: SEMCAD, V1.8 Build 159

**Front of EUT Facing Phantom - Middle 2/Area Scan (61x101x1):** Measurement grid: dx=15mm, dy=15mm

Maximum value of SAR (interpolated) = 0.231 mW/g

**Front of EUT Facing Phantom - Middle 2/Zoom Scan (5x5x7) 2 (7x7x7)/Cube 0:** Measurement grid: dx=5mm, dy=5mm, dz=5mm

Reference Value = 15.6 V/m; Power Drift = -0.025 dB

Peak SAR (extrapolated) = 0.263 W/kg

**SAR(1 g) = 0.217 mW/g; SAR(10 g) = 0.168 mW/g**

Maximum value of SAR (measured) = 0.227 mW/g



020: Front of EUT-Body-Worn\_LTE FDD 17\_10MHz 1RB Mid\_CH23790

Date: 09/04/2015

DUT: A1428; Sleeve: Linea Pro 5; Sleeve contains FCC ID: YRWDATECSBT301

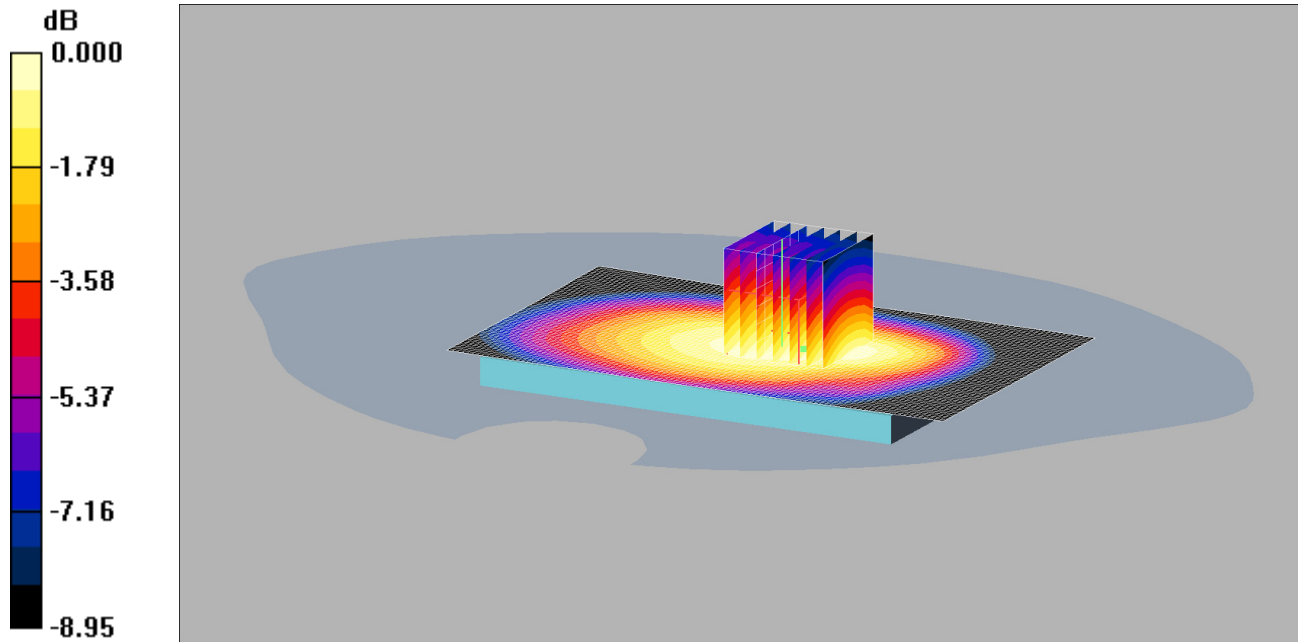

0 dB = 0.192mW/g

Communication System: LTE - Band 17 / 10MHz Channel; Frequency: 710 MHz; Duty Cycle: 1:1

Medium: 750/900 MHz MSL Medium parameters used (interpolated): f = 710 MHz;  $\sigma = 0.94$  mho/m;  $\epsilon_r = 54.4$ ;  $\rho = 1000$  kg/m<sup>3</sup>

Phantom section: Flat Section

DASY4 Configuration:

- Probe: ET3DV6 - SN1529; ConvF(6.15, 6.15, 6.15);
- Sensor-Surface: 4mm (Mechanical Surface Detection)
- Electronics: DAE3 Sn394; Calibrated: 16/05/2014
- Phantom: SAM 12a (Site 56); Type: SAM 4.0; Serial: TP:1020
- Measurement SW: DASY4, V4.6 Build 19; Postprocessing SW: SEMCAD, V1.8 Build 159

**Front of EUT Facing Phantom - Middle 2/Area Scan (61x101x1):** Measurement grid: dx=15mm, dy=15mm

Maximum value of SAR (interpolated) = 0.190 mW/g

**Front of EUT Facing Phantom - Middle 2/Zoom Scan (5x5x7) 2 (7x7x7)/Cube 0:** Measurement grid: dx=5mm, dy=5mm, dz=5mm

Reference Value = 14.2 V/m; Power Drift = -0.001 dB

Peak SAR (extrapolated) = 0.231 W/kg

**SAR(1 g) = 0.182 mW/g; SAR(10 g) = 0.137 mW/g**

Maximum value of SAR (measured) = 0.192 mW/g

021: Touch Right\_Wi-Fi 2.4GHz\_802.11b 1Mbps\_CH6

Date: 15/04/2015

DUT: A1428; Sleeve: Linea Pro 5; Sleeve contains FCC ID: YRWDATECSBT301

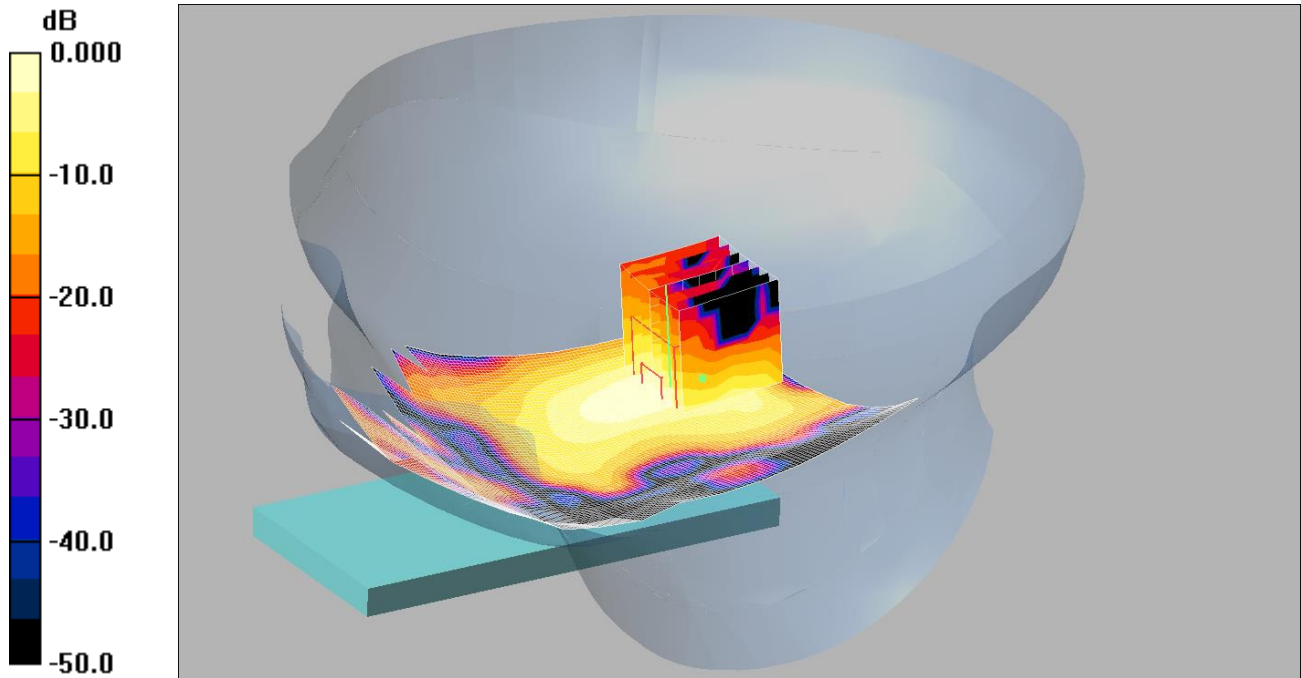

0 dB = 0.113mW/g

Communication System: WLAN; Frequency: 2437 MHz; Duty Cycle: 1:1

Medium: 2450 MHz HSL Medium parameters used (interpolated):  $f = 2437$  MHz;  $\sigma = 2.01$  mho/m;  $\epsilon_r = 52.1$ ;  $\rho = 1000$  kg/m<sup>3</sup>

Phantom section: Right Section

DASY4 Configuration:

- Probe: ES3DV3 - SN3304; ConvF(4.24, 4.24, 4.24);
- Sensor-Surface: 4mm (Mechanical Surface Detection)
- Electronics: DAE3 Sn432; Calibrated: 20/08/2014
- Phantom: SAM 12a (Site 57); Type: SAM 4.0; Serial: TP:1020
- Measurement SW: DASY4, V4.7 Build 80; Postprocessing SW: SEMCAD, V1.8 Build 186

**Touch Right - Middle/Area Scan (91x151x1):** Measurement grid: dx=12mm, dy=12mm

Maximum value of SAR (interpolated) = 0.131 mW/g

**Touch Right - Middle/Zoom Scan (7x7x7) (7x7x7)/Cube 0:** Measurement grid: dx=5mm, dy=5mm, dz=5mm

Reference Value = 6.89 V/m; Power Drift = 0.167 dB

Peak SAR (extrapolated) = 0.226 W/kg

**SAR(1 g) = 0.098 mW/g; SAR(10 g) = 0.037 mW/g**

Maximum value of SAR (measured) = 0.113 mW/g

Note: SAR level measured is very low as equivalent to noise floor.

022: Back of EUT-Body-Worn\_Wi-Fi 2.4GHz\_802.11b 1Mbps\_CH6

Date: 10/04/2015

DUT: A1428; Sleeve: Linea Pro 5; Sleeve contains FCC ID: YRWDATTECSBT301

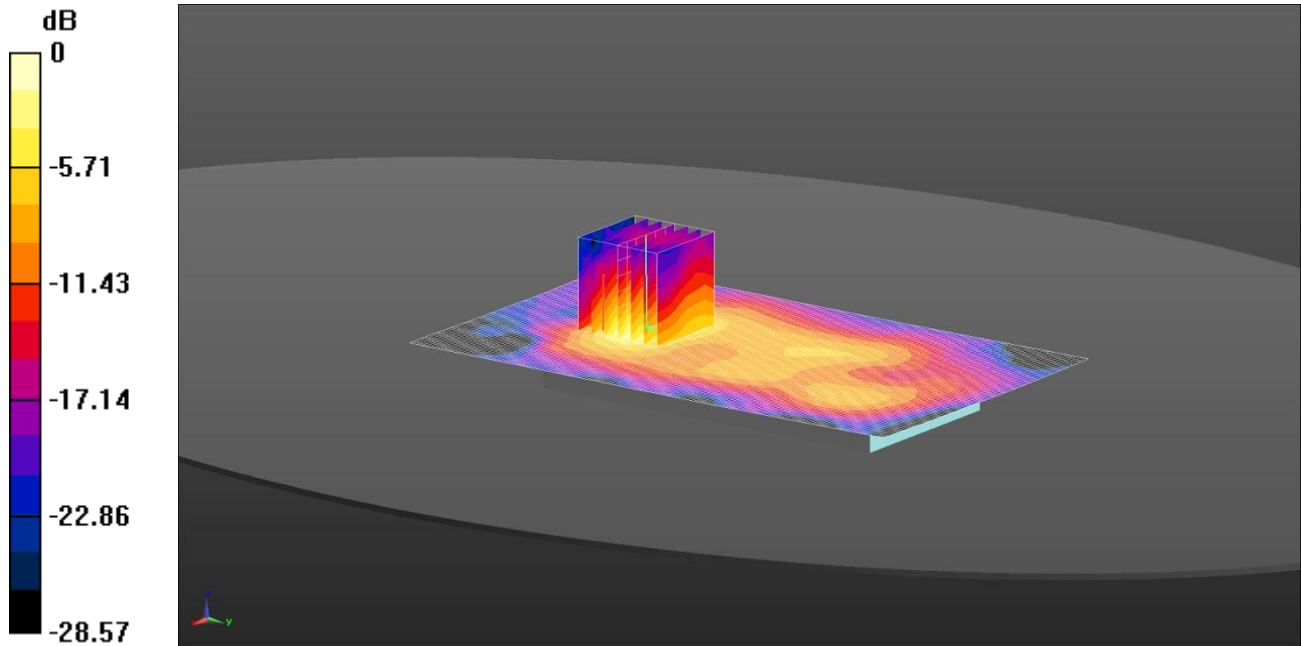

0 dB = 0.0980 W/kg = -10.09 dBW/kg

Communication System: UID 0 - n/a, WLAN; Frequency: 2437 MHz; Duty Cycle: 1:1

Medium: 2450 MHz MSL Medium parameters used (interpolated):  $f = 2437$  MHz;  $\sigma = 2.006$  S/m;  $\epsilon_r = 52.601$ ;  $\rho = 1000$  kg/m<sup>3</sup>

Phantom section: Flat Section

DASY4 Configuration:

- Probe: ES3DV3 - SN3304; ConvF(4.24, 4.24, 4.24); Calibrated: 21/08/2014;
- Sensor-Surface: 4mm (Mechanical Surface Detection)
- Electronics: DAE3 Sn432; Calibrated: 20/08/2014
- Phantom: ELI v5.0; Type: QDOVA002AA; Serial: TP:xxxx
- ; SEMCAD X Version 14.6.9 (7117)

**Configuration/Back of EUT Facing Phantom - Middle 2/Area Scan (91x151x1):** Interpolated grid: dx=1.200 mm, dy=1.200 mm

Maximum value of SAR (interpolated) = 0.101 W/kg

**Configuration/Back of EUT Facing Phantom - Middle 2/Zoom Scan (7x7x7) 2 (7x7x7)/Cube 0:** Measurement grid:

dx=5mm, dy=5mm, dz=5mm

Reference Value = 4.654 V/m; Power Drift = -0.54 dB

Peak SAR (extrapolated) = 0.169 W/kg

**SAR(1 g) = 0.083 W/kg; SAR(10 g) = 0.037 W/kg**

Maximum value of SAR (measured) = 0.0980 W/kg

Note: SAR level measured is very low as equivalent to noise floor.

023: Touch Right\_Wi-Fi\_5GHz\_802.11a\_6Mbps\_CH48  
 Date: 17/04/2015

DUT: A1428; Sleeve: Linea Pro 5; Sleeve contains FCC ID: YRWDTECSBT301

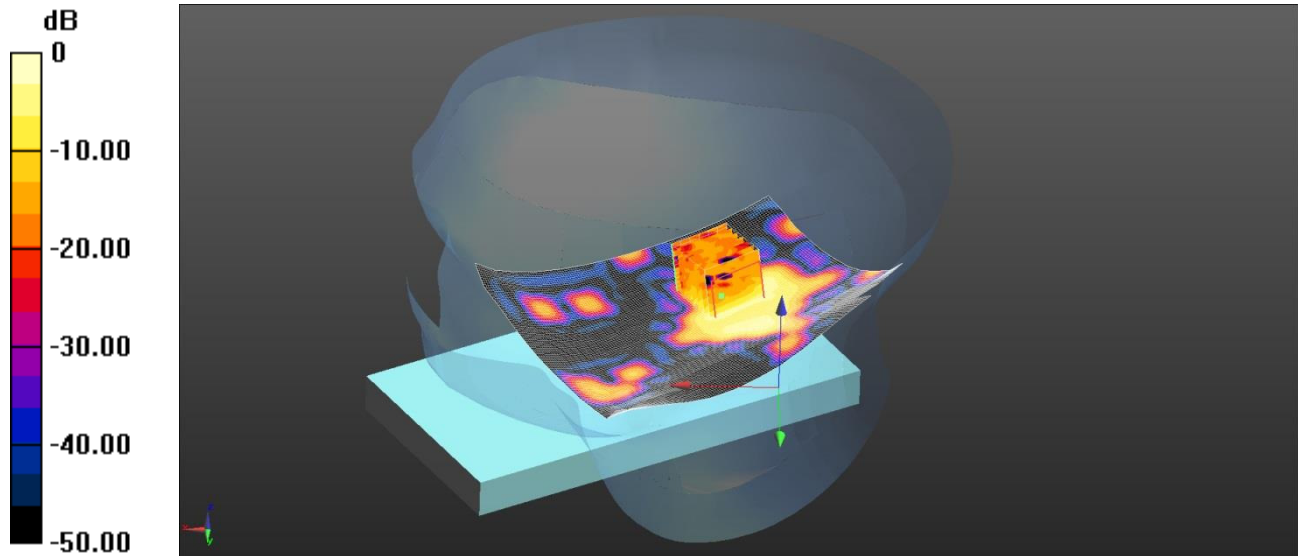

0 dB = 0.406 W/kg = -3.91 dBW/kg

Communication System: UID 0, WLAN 802.11 (0); Frequency: 5240 MHz; Duty Cycle: 1:1  
 Medium: 5200/5500/5800 MHz HSL Medium parameters used (interpolated):  $f = 5240$  MHz;  $\sigma = 4.572$  S/m;  $\epsilon_r = 34.511$ ;  $\rho = 1000$  kg/m<sup>3</sup>

Phantom section: Right Section

DASY4 Configuration:

- Probe: EX3DV4 - SN3994; ConvF(5.3, 5.3, 5.3); Calibrated: 17/03/2015;
- Sensor-Surface: 4mm (Mechanical Surface Detection)
- Electronics: DAE3 Sn450; Calibrated: 16/09/2014
- Phantom: SAM (20deg probe tilt) with CRP v4.0; Type: QD000P40CC; Serial: TP:xxxx
- ; SEMCAD X Version 14.6.10 (7164)

**Configuration/Touch Right/Area Scan (131x111x1):** Interpolated grid: dx=1.000 mm, dy=1.000 mm  
 Maximum value of SAR (interpolated) = 0.401 W/kg

**Configuration/Touch Right/Zoom Scan (7x7x12) 2 2 (7x7x12)/Cube 0:** Measurement grid: dx=4mm, dy=4mm, dz=2mm  
 Reference Value = 2.055 V/m; Power Drift = 0.18 dB  
 Peak SAR (extrapolated) = 0.970 W/kg  
**SAR(1 g) = 0.312 W/kg; SAR(10 g) = 0.097 W/kg**  
 Maximum value of SAR (measured) = 0.406 W/kg

024: Front of EUT-Body-Worn\_Wi-Fi 5GHz\_802.11a 6Mbps\_CH48

Date: 09/04/15

DUT: A1428; Sleeve: Linea Pro 5; Sleeve contains FCC ID: YRWDATECSBT301

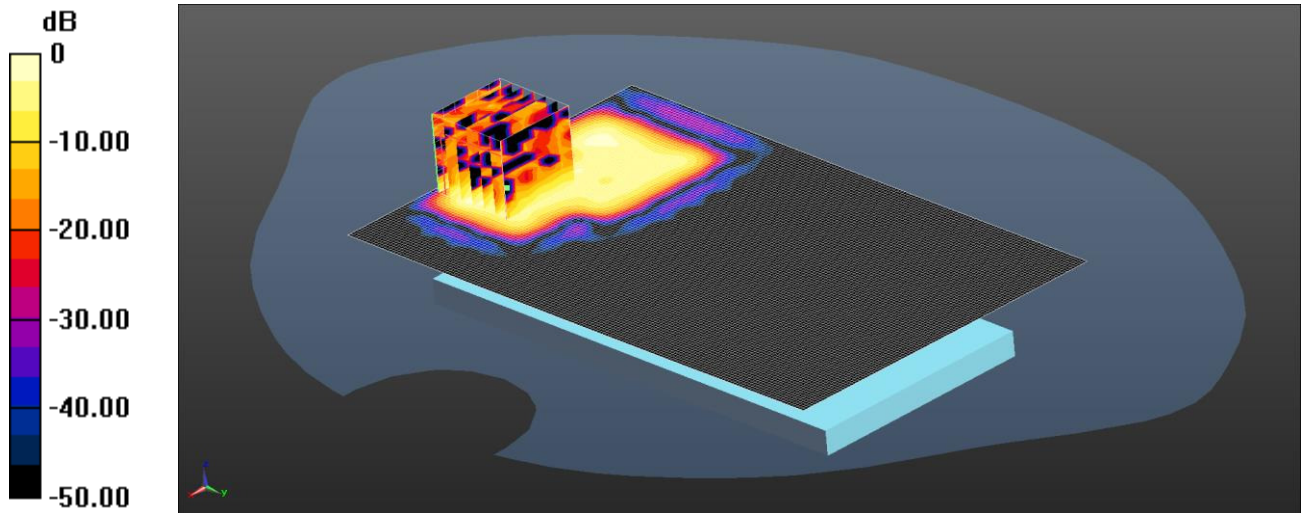

0 dB = 0.107 W/kg = -9.71 dBW/kg

Communication System: UID 0, WLAN 802.11 (0); Frequency: 5240 MHz; Duty Cycle: 1:1

Medium: 5GHz MSL Medium parameters used (interpolated):  $f = 5240$  MHz;  $\sigma = 5.309$  S/m;  $\epsilon_r = 48.61$ ;  $\rho = 1000$  kg/m<sup>3</sup>

Phantom section: Flat Section

DASY4 Configuration:

- Probe: EX3DV4 - SN3814; ConvF(4.38, 4.38, 4.38); Calibrated: 18/09/14;
- Sensor-Surface: 4mm (Mechanical Surface Detection)
- Electronics: DAE4 Sn1435; Calibrated: 15/04/14
- Phantom: SAM (20deg probe tilt) with CRP v4.0; Type: QD000P40CC; Serial: TP:xxxx
- ; SEMCAD X Version 14.6.10 (7331)

**Configuration/Bottom of EUT Facing Phantom/Area Scan (101x161x1):** Interpolated grid: dx=1.000 mm, dy=1.000 mm

Maximum value of SAR (interpolated) = 0.132 W/kg

**Configuration/Bottom of EUT Facing Phantom/Zoom Scan (7x7x12) (7x7x12)/Cube 0:** Measurement grid: dx=4mm, dy=4mm, dz=2mm

Reference Value = 2.804 V/m; Power Drift = -0.17 dB

Peak SAR (extrapolated) = 0.502 W/kg

**SAR(1 g) = 0.078 W/kg; SAR(10 g) = 0.026 W/kg**

Maximum value of SAR (measured) = 0.107 W/kg

Note: SAR level measured is very low as equivalent to noise floor.