



pkm electronic GmbH

Prüfbericht / Test report

Test-Firm-Registration-Number: 90870

FCC
(Federal Communications Commission)



**TESTED
IN GERMANY**

Ohmstrasse 1
84160 Frontenhausen, Germany
Tel.: + 49 (0) 8732 - 6381
Fax: + 49 (0) 8732 - 2345
E-mail: pkm.accredited-labs@t-online.de

Prüfbericht Nr./
Test report no.: **11/01-0105**

Seite 1 von 15 Seiten
Page 1 of 15 pages



TABLE OF CONTENTS

	Page
1. CLIENT INFORMATION	3
2. EQUIPMENT UNDER TEST	3
3. TEST SITE	4
4. CALIBRATIONS OF MEASURING INSTRUMENTS	4
5. DESCRIPTION OF THE TEST CONDITIONS	4-6
6. MEASURING INSTRUMENTS AND SET-UP	7-9
7. MEASUREMENTS AND RESULTS	10
8. CONCLUSIONS	11
9. LIST OF USED TEST EQUIPMENT AT PKM	12
10. PHOTOS	13-15
11. ANNEX 1 / TEST DATA	1-12

Note:

The test equipments used at pkm are calibrated by an external DKD-calibration laboratory. Calibration documents are available upon request.



1. CLIENT INFORMATION:

Name: DATECS Ltd.
Address: bul. Tzarigradsko shosse 115A, Fl.4, 1784 SOFIA - BULGARIA
Name of contact: Mr. P. Iliev, Vice President / Mrs. Ludmila Nikolova
Telephone: 00359 2 8165 550
Fax: 00359 2 9741 100
E-mail: pencho@datecs.bg / lusi@datecs.bg

2. EQUIPMENT UNDER TEST:

2.1 Identification of the EUT

Equipment: Scanner
Model: LINEA PRO 4.0
Brand name: -/-
Serial no.: -/-
Manufacturer: DATECS Ltd.
Country of origin: BULGARIA
Rating: Lithium-Ion battery ICP663450M 3.7V 1300mA / 5V DC, powered by USB

2.2 Additional information about the EUT: In course of this test report only the EMC measurements of the Scanner function are performed (part 15 subpart B, unintentional radiator). The conformity of the Radio part for this product is shown by separate report.

3. TEST SITE

3.1. Shielded room for conducted emission

Measurement of conducted emission from EUT was made in the shielded chamber (Siemens DC-10GHz) that has been found in compliance with Federal Communications Commissions (FCC) requirements of clause 2.948 according to ANSI C63.4-2003 on March 04, 2009.

3.2. Semi-anechoic chamber/OATS for radiated emission

Measurement of radiated emissions from EUT was made in the semi-anechoic chamber that has been found in compliance with Federal Communications Commissions (FCC) requirements of clause 2.948 according to ANSI C63.4-2003 on March 04, 2009.

3.3 Cable input conducted emission

Measurement of cable input conducted emission from EUT was made in the semi-anechoic chamber that has been found in compliance with Federal Communications Commissions (FCC) requirements of clause 2.948 according to ANSI C63.4-2003 on March 04, 2009.

4. CALIBRATIONS OF MEASURING INSTRUMENTS

All measurements were made with instruments calibrated according to the requests of EN/IEC 17025 according to which the test site is accredited. Measurement of radiated emissions was made with instruments conforming to American National Standard Specification, ANSI C63.4-2003. The calibration of measuring instrument, including any accessories that may affect test results, was performed according to the requests of EN/IEC 17025.

5. DESCRIPTION OF THE TEST CONDITIONS

5.1 Conducted emission measurements

5.1.1 Test site

Measurements were made in shielded chamber as described at 3.1 in this report.

5.1.2 Detector function selection and bandwidth

In conducted emissions measurement CISPR quasi-peak- and average-detector were used. The bandwidth of the detector of instrument is 10 kHz over the frequency range of 150 kHz to 30 MHz, Conducted emission is detected in CCIR quasi-peak- and average-mode.

5.1.3 Unit of measurement

Test results of conducted emission measurement are reported in dB μ V.

5.1.4 Frequency range to be scanned

For conducted emission measurements, the spectrum in the range of 150 kHz to 30 MHz was investigated.

5.1.5 Test conditions and configuration of EUT

The EUT was configured and operated in all modes of operation so as to find the maximum conducted emission generated from EUT.

The power was furnished with rated (normal) power, as specified in the owner's manual of EUT. The EUT was placed on a 80 cm high non metallic table.

Each type of accessory provided by manufacturer or typically used and support equipment were connected to the EUT during measurements as for the typical usage and applicable as nearly as practicable.

5.1.6 Measurement uncertainty

Conducted emission measurements: ± 1.8 dB

The measurement uncertainty describes the overall uncertainty of the given measured value during the operation of the EUT in the above mentioned way.

The measurements uncertainty was calculated in accordance with NAMAS NIS 81: "The treatment of uncertainty in EMC measurement" and "Guide to the Expression of Uncertainty in Measurement (GUM)".

The measurement uncertainty was given with a confidence of 95%.

5.2 Radiated emissions measurements

5.2.1 Test site

Measurements were made in semi-anechoic chamber as described at 3.2 in this report.

5.2.2 Detector function selection and bandwidth

In radiated emissions measurement, field strength meters that have CISPR quasi-peak and average were used. The bandwidth of the detector of instrument is 120 KHz over frequency range of 30 to 1000 MHz, emissions to be measured are detected in CCIR quasi peak mode.

The bandwidth of the detector of instrument is 1000 KHz for frequencies above 1000 MHz, emissions to be measured are detected in average mode.

5.2.3 Unit of measurement

Test results of radiated emissions measurement are reported in dB(microvolts per meter) at the specific distance. Using the unit of dB μ V on the test instrument, the indication unit can be converted to field strength unit of μ V/m as following method for frequencies 30 MHz – 1000 MHz;

$$F/S = 10^{[(R + CF)/20]}$$

here,

F/S: Field strength in μ V/m

R: Meter reading in dB (μ V)

CF: Correction factor (includes cable loss, antenna factor, field deviation)

5.2.4 Antennas

Measurements were made using a calibrated bilog antenna in the range of 30 to 1000 MHz and a calibrated horn antenna above 1000MHz to determine the emission characteristics of the EUT. Measurements were also made for both horizontal and vertical polarization.

The horizontal distance between the receiving antenna and the closest periphery of the EUT is 3 meters.

5.2.5 Frequency range to be scanned

For radiated emissions measurements, the spectrum in the range of 30 to 1000 MHz was investigated and above 1000MHz up to the 5th harmonic of the highest frequency or 40GHZ, whichever is lower.

5.2.6 Test conditions and configuration of EUT

The EUT was configured and operated in all modes of operation so as to find the maximum RF energy generated from EUT.

The power was furnished with rated (normal) Power, as specified in the owner's manual of EUT. The EUT was placed on a 80 cm high non metallic 1m diameter table. The turntable containing the system was rotated and the antenna height was varied 1m to 4 m to find the maximum RF energy generated from EUT.

Each type of accessory provided by manufacturer or typically used and support equipment were connected to the EUT during measurements to the typical usage and applicable as nearly as practicable.

5.2.7 Measurement uncertainty

Radiated emissions measurements, bilog antenna: ± 2.7 dB, horn antenna ± 2.9 dB

The measurement uncertainty describes the overall uncertainty of the given measured value during the operation of the EUT in the above mentioned way.

The measurements uncertainty was calculated in accordance with NAMAS NIS 81: "The treatment of uncertainty in EMC measurement" and "Guide to the Expression of Uncertainty in Measurement (GUM)".

The measurement uncertainty was given with a confidence of 95 %.

5.3 Cable input conducted emission measurements

5.3.1 Test site

Measurements were made in shielded chamber as described at 3.3 in this report.

5.3.2 Detector function selection and bandwidth

In conducted cable input emissions measurement CISPR quasi-peak were used.

The bandwidth of the detector of instrument is 120 KHz over frequency range of 30 MHz to 1000 MHz, Conducted cable input emission is detected in CCIR quasi peak mode.

5.3.3 Unit of measurement

Test results of conducted emission measurement are reported in dB μ V. Using the unit of dB μ V on the test instrument, indication unit was converted to voltage unit of μ V as following method for frequencies 30 MHz – 1000 MHz;

$$U = 10^{[R/20]}$$

here,

U: Voltage of conducted emission in μ V

R: Meter reading in dB(μ V)

5.3.4 Frequency range to be scanned

For conducted cable input emission measurements, the spectrum in the range of 54 MHz to 804 MHz was investigated.

5.3.5 Test conditions and configuration of EUT

The EUT was configured and operated in all modes of operation so as to find the maximum conducted emission generated from EUT.

The power was furnished with rated (normal) Power, as specified in the owner's manual of EUT. The EUT was placed on a 1 m high non metallic table.

Each type of accessory provided by manufacturer or typically used and support equipment were connected to the EUT during measurements to the typical usage and applicable as nearly as practicable.

5.3.6 Measurement uncertainty

Conducted cable input emission measurements: ± 1.3 dB

The measurement uncertainty describes the overall uncertainty of the given measured value during the operation of the EUT in the above mentioned way.

The measurements uncertainty was calculated in accordance with NAMAS NIS 81: "The treatment of uncertainty in EMC measurement" and "Guide to the Expression of Uncertainty in Measurement (GUM)".

The measurement uncertainty was given with a confidence of 95 %.

6. MEASURING INSTRUMENTS AND SET-UP

6.1 Conducted emission

6.1.1 Test receiver

Rohde & Schwarz, model ESHS-30 (9 kHz – 30 MHz)
Detector function: quasi peak
IF bandwidth: 10 kHz

6.1.2 Mains network

Rohde & Schwarz, model ESH2-Z5 (9 kHz – 30 MHz)

6.1.3 Measurement setup

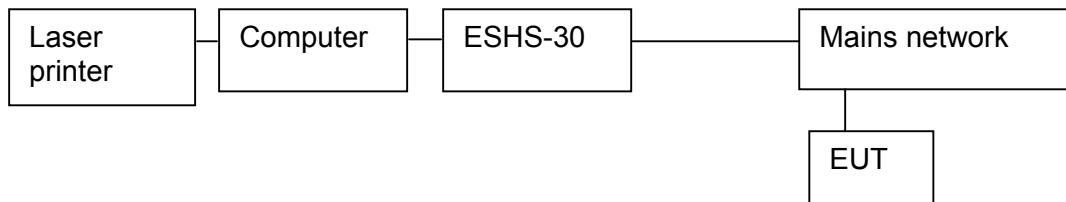

6.2 Radiated emission

6.2.1 Test receiver

Rohde & Schwarz, model ESVS-30 (20 MHz – 1000 MHz)
Detector function: quasi peak
IF bandwidth: 120kHz
Rohde & Schwarz, model FSMS26 (above 1000MHz)
Schwarzbeck, Preamplifier model BBV 9718 1GHz - 18GHz
Detector function: average
IF bandwidth: 1000kHz

6.2.2 Receiving antenna

Chase, model CBL6111: bilog antenna (30 MHz – 1000 MHz)
Electro Metric RGA 50/60 horn antenna (above 1000MHz)

6.2.3 Measurement setup

30MHz - 1000MHz

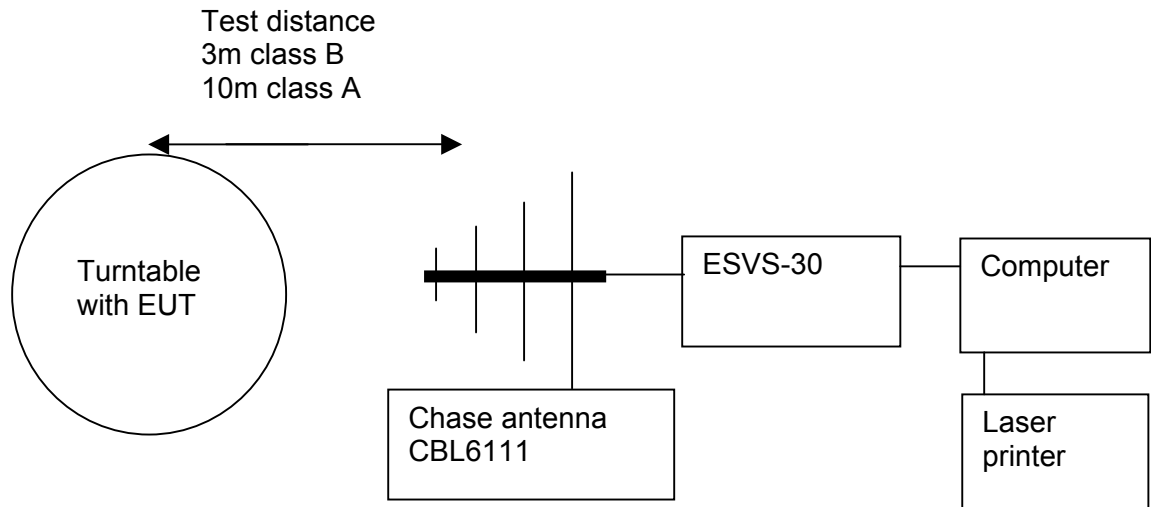

above 1000MHz

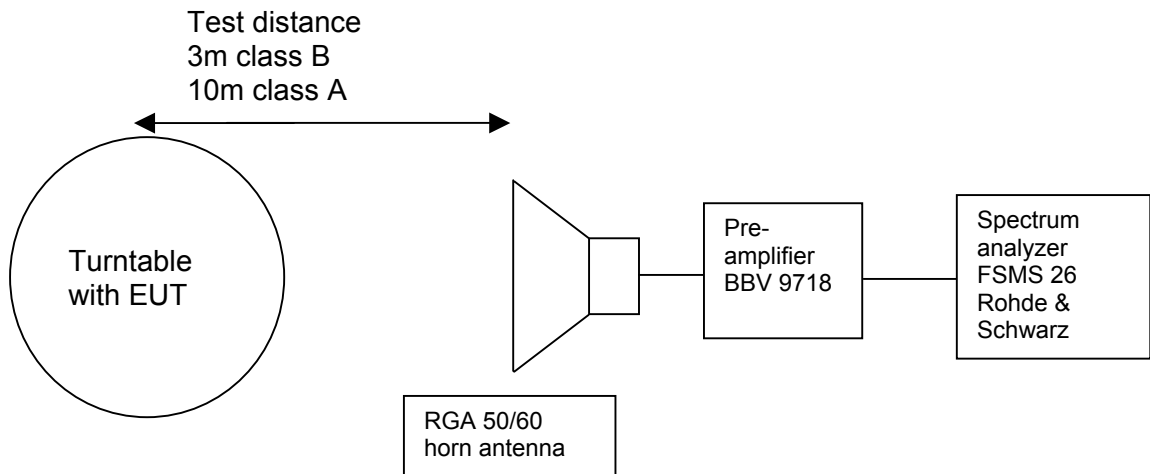

6.3 Cable input conducted emission

6.3.1 Test receiver

Rohde & Schwarz, model ESVS-30 (20 MHz – 1000 MHz)
Detector function: quasi peak
IF bandwidth: 120 kHz

6.3.2 Power divider

Model 50 Ohm-6 dB, Suhner
DC- 2000 MHz

6.3.3 Converter (matching network) 50/75 Ohm

Model ZM57, Texscan

6.3.4 Measurement setup

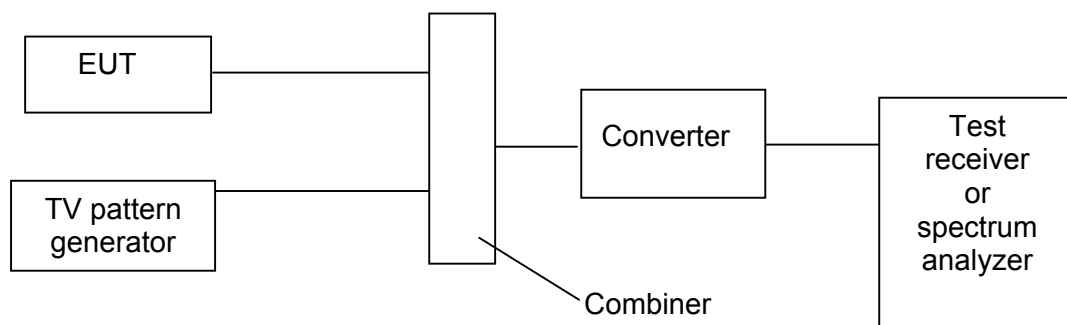



7. MEASUREMENTS AND RESULTS

7.1 Conducted emission

The EUT is battery operated or powered by USB (5V DC) and has no connection facility to mains power.

7.2 Radiated emission

Tests have been performed with an iPod connected in the modes USB connected to PC (charge mode), Bluetooth connection (printing on Bluetooth printer), card reading and barcode scanning. As the highest frequency generated is less than 1 GHz, frequencies up to 5 GHz have been investigated. The EUT complied with the requirements of section 15.109 (a) class B.

7.3 Cable input conducted emission

As the EUT has no connection facility to an external antenna or cable network, no cable input conducted emission can be measured.



TESTED
IN GERMANY

Prüfbericht Nr./Test report no.:
11/01-0105

Seite 11 von 15 Seiten
Page 11 of 15 pages

CONCLUSIONS:

From the measurement data obtained, the tested sample was considered to have **COMPLIED** with the requirements for the relevant clauses of Federal Communications Commission Rules for unintentional radiators (part 15 subpart B)

Zuständiger Laborleiter:
Responsible head of laboratory:

09.02.2011

(Datum/Date)

G. Raithel Dipl.-Ing. (FH)

(Name/Name)



electronic GmbH

Ohmstrasse 1

84160 Frontenhausen

Tel.: + 49 (0) 8732 - 6381

Fax: + 49 (0) 8732 - 2345

E-mail: pkm.accredited-labs@t-online.de

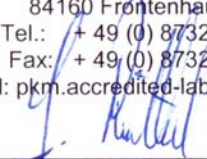
(Unterschrift/Signature)



9. LIST OF USED TEST EQUIPMENT AT PKM

Test place	Kind of equipment	Type	Manufacturer	pkm-ident no.
Conducted emissions cabin 1 9kHz - 30MHz	EMI test receiver	ESHS-30	Rohde&Schwarz	10571
	Line impedance stabilisation network	ESH2-Z5	Rohde&Schwarz	10139
	Shielded room	1 GHz Typ B83102	Siemens	10111
Radiated emissions 30MHz - 1000MHz	EMI test receiver	ESVS-30	Rohde&Schwarz	10572
	EMI test antenna	CBL6111	Chase	10022
	Antenna mast system	AM9104	Schwarzbeck	10099
	AC-linefilter	FV2-10-D	Timonta	10755
	Turntable	DT 310	Deisel	10774
Cable input conducted emissions	TV-test transmitter	VTG700SAT	Grundig	10531
	Spectrum analyzer	HP8562B	Hewlett Packard	10208
	EMI test receiver	ESVS-30	Rohde&Schwarz	10572
	50/75 Ohm converter	ZM57	Texscan	10305
	Power divider	50 Ohm-6dB	Suhner	10421
Interference radiation 1000MHz – 18GHz	Spectrum analyzer (100Hz – 26.5GHz)	FSMS 26	Rohde & Schwarz	10481 / 10482
	Horn antenna (1GHz – 18GHz)	RGA-50/60	Electro Metrics	10018
	Broadband-Preamplifier 1-18 GHz	BBV 9718	Schwarzbeck	11230
	Antenna mast system	AM9104	Schwarzbeck	10099
	AC-linefilter	FV2-10-D	Timonta	10755
	Turntable	DT 310	Deisel	10774
	Frequency measurements	Spectrum analyzer (100Hz – 26.5GHz)	FSMS 26	Rohde & Schwarz
Antenna mast system		AM9104	Schwarzbeck	10099
AC linefilter		FV2-10-D	Timonta	10755
Turntable		DT 310	Deisel	10774

The test equipments used at pkm are calibrated by an external DKD-calibration laboratory. Calibration documents are available upon request.

10. PHOTOS





TESTED
IN GERMANY

Prüfbericht Nr./Test report no.:
11/01-0105

Seite 14 von 15 Seiten
Page 14 of 15 pages





End of test report



electronic GmbH
Frontenhausen

IT 5/6

Interference Radiation 30 MHz - 1000 MHz
acc. FCC Part 15 Subpart B Section 15.109(a) Class B



TESTED
IN GERMANY

Annex 1 / Test data
11/01-0105

Seite 1 von 12 Seiten
Page 1 of 12 pages

Ref.-No.: 11/01-0105
Product: SCANNER
Sample: 01
Date: 8 Feb 2011
Operator: BL

Test equipment:
Rohde & Schwarz ESVS
CHASE CBL 6111

Connected sets:
ALL CABLES

Operating mode:
BLUETOOTH CONNECTED

test distance 3m
RFI suppression parts:

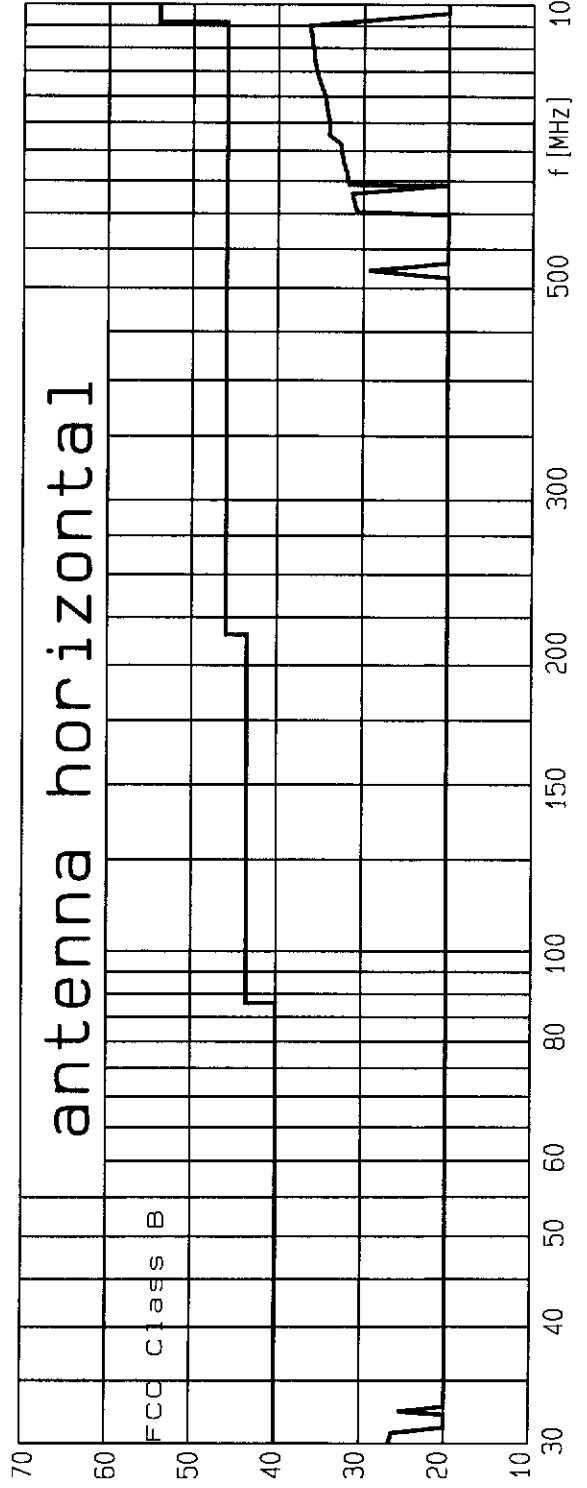
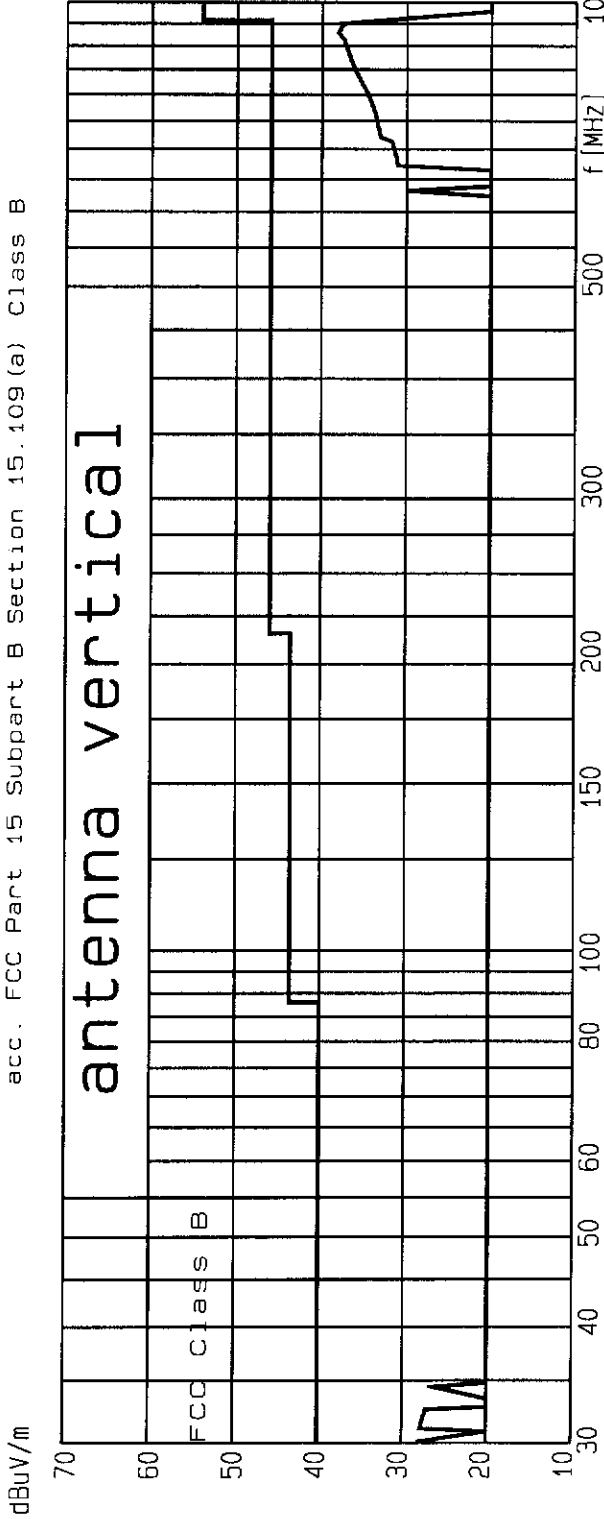

Result: pass fail []

the highest points found:

freq. [MHz]	tested dBuV/m	limit h/v	pol.
928	38.08	46	v
949.12	37.63	46	v
947.76	37.57	46	v
913.56	37.41	46	v
885.16	36.88	46	v
949.36	36.27	46	h
939.04	36.25	46	h
930.88	36.18	46	h
905.64	36.01	46	h
898.64	35.9	46	h

* - IF ANY MEANS: EMISSION NOT COUNTED FOR JUDGEMENT



TESTED
IN GERMANY

Annex 1 / Test data
11/01-0105

Seite 2 von 12 Seiten
Page 2 of 12 pages



electronic GmbH
Frontenhausen

Ref.-No.: 11/01-0105
Product : SCANNER
Sample : 01
Date : 8 Feb 2011
Operator: BL

OPERATION MODE:
BLUETOOTH CONNECTED

195	HOR.	FRQ.:	905.64	MHz	LEV.:	36.01	dBuV/m	Lim.:	46	dBuV/m
196	HOR.	FRQ.:	930.88	MHz	LEV.:	36.18	dBuV/m	Lim.:	46	dBuV/m
197	HOR.	FRQ.:	939.04	MHz	LEV.:	36.25	dBuV/m	Lim.:	46	dBuV/m
198	HOR.	FRQ.:	949.36	MHz	LEV.:	36.27	dBuV/m	Lim.:	46	dBuV/m
191	VER.	FRQ.:	850.76	MHz	LEV.:	36.16	dBuV/m	Lim.:	46	dBuV/m
192	VER.	FRQ.:	865.12	MHz	LEV.:	36.47	dBuV/m	Lim.:	46	dBuV/m
193	VER.	FRQ.:	872.4	MHz	LEV.:	36.65	dBuV/m	Lim.:	46	dBuV/m
194	VER.	FRQ.:	885.16	MHz	LEV.:	36.88	dBuV/m	Lim.:	46	dBuV/m
195	VER.	FRQ.:	913.56	MHz	LEV.:	37.41	dBuV/m	Lim.:	46	dBuV/m
196	VER.	FRQ.:	928	MHz	LEV.:	38.08	dBuV/m	Lim.:	46	dBuV/m
197	VER.	FRQ.:	947.76	MHz	LEV.:	37.57	dBuV/m	Lim.:	46	dBuV/m
198	VER.	FRQ.:	949.12	MHz	LEV.:	37.63	dBuV/m	Lim.:	46	dBuV/m



electronic GmbH
Frontenhausen

IT 5/6

Interference Radiation 30 MHz - 1000 MHz
acc. FCC Part 15 Subpart B Section 15.109(a) Class B

Ref.-No.: 11/01-0105
Product: SCANNER
Sample: 01
Date: 8 Feb 2011
Operator: BL

Test equipment:
Rohde & Schwarz ESVS
CHASE CBL 6111

Connected sets:
ALL CABLES

Operating mode:
BARCODE SCANNING

test distance 3m
RFI suppression parts:



TESTED
IN GERMANY

Annex 1 / Test data
11/01-0105

Seite 3 von 12 Seiten
Page 3 of 12 pages

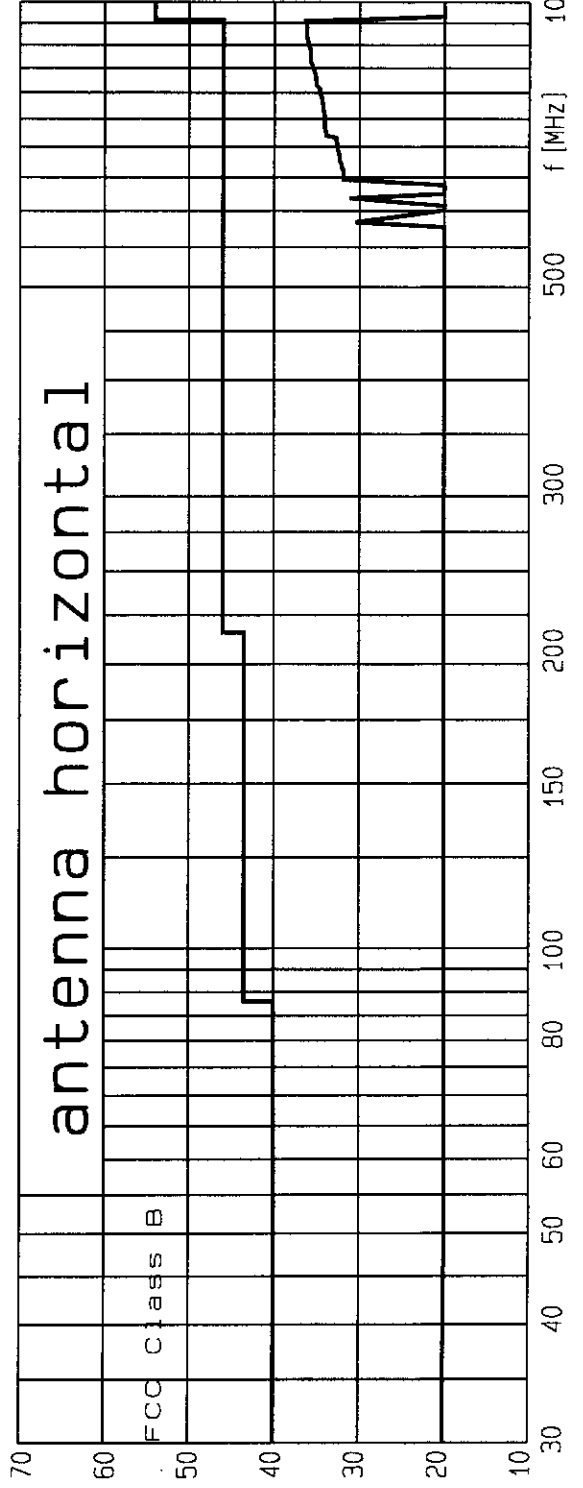
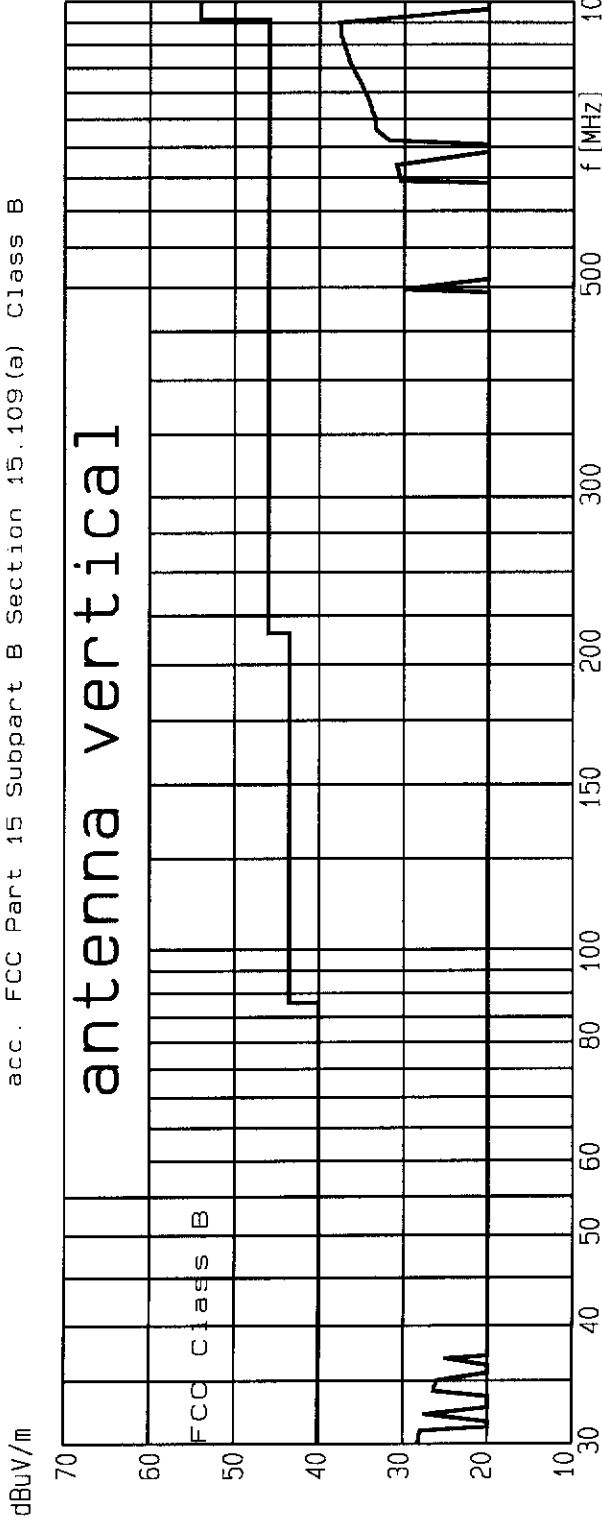

Result: pass fail []

the highest points found:

freq. [MHz]	tested dBuV/m	limit dBuV/m	pol. h/v
949.64	37.59	46	v
921.56	37.51	46	v
938.64	37.51	46	v
912.2	37.32	46	v
892.08	36.99	46	v
953.92	36.31	46	h
924.6	36.22	46	h
939.4	36.17	46	h
908.6	36.09	46	h
889.6	35.81	46	h

* - IF ANY MEANS: EMISSION NOT COUNTED
FOR JUDGEMENT



TESTED
IN GERMANY

Annex 1 / Test data
11/01-0105

Seite 4 von 12 Seiten
Page 4 of 12 pages



electronic GmbH
Frontenhausen

Ref.-No.: 11/01-0105
Product : SCANNER
Sample : 01
Date : 8 Feb 2011
Operator: BL

OPERATION MODE:
BARCODE SCANNING

195	HOR.	FRQ.:	908.6	MHz	LEV.:	36.09	dBuV/m	Lim.:	46	dBuV/m
196	HOR.	FRQ.:	924.6	MHz	LEV.:	36.22	dBuV/m	Lim.:	46	dBuV/m
197	HOR.	FRQ.:	939.4	MHz	LEV.:	36.17	dBuV/m	Lim.:	46	dBuV/m
198	HOR.	FRQ.:	953.92	MHz	LEV.:	36.31	dBuV/m	Lim.:	46	dBuV/m
192	VER.	FRQ.:	864.88	MHz	LEV.:	36.54	dBuV/m	Lim.:	46	dBuV/m
193	VER.	FRQ.:	867.52	MHz	LEV.:	36.51	dBuV/m	Lim.:	46	dBuV/m
194	VER.	FRQ.:	892.08	MHz	LEV.:	36.99	dBuV/m	Lim.:	46	dBuV/m
195	VER.	FRQ.:	912.2	MHz	LEV.:	37.32	dBuV/m	Lim.:	46	dBuV/m
196	VER.	FRQ.:	921.56	MHz	LEV.:	37.51	dBuV/m	Lim.:	46	dBuV/m
197	VER.	FRQ.:	938.64	MHz	LEV.:	37.51	dBuV/m	Lim.:	46	dBuV/m
198	VER.	FRQ.:	949.64	MHz	LEV.:	37.59	dBuV/m	Lim.:	46	dBuV/m

Interference Radiation 30 MHz - 1000 MHz
acc. FCC Part 15 Subpart B Section 15.109 (a) Class B



TESTED
IN GERMANY

Annex 1 / Test data
11/01-0105

Seite 5 von 12 Seiten
Page 5 of 12 pages

Ref.-No.: 11/01-0105
Product: SCANNER
Sample: 01
Date: 8 Feb 2011
Operator: BL

Test equipment:
Rohde & Schwarz ESVS
CHASE CBL 6111

Connected sets:
ALL CABLES

Operating mode:
CARD READING

test distance 3m

RFI suppression parts:

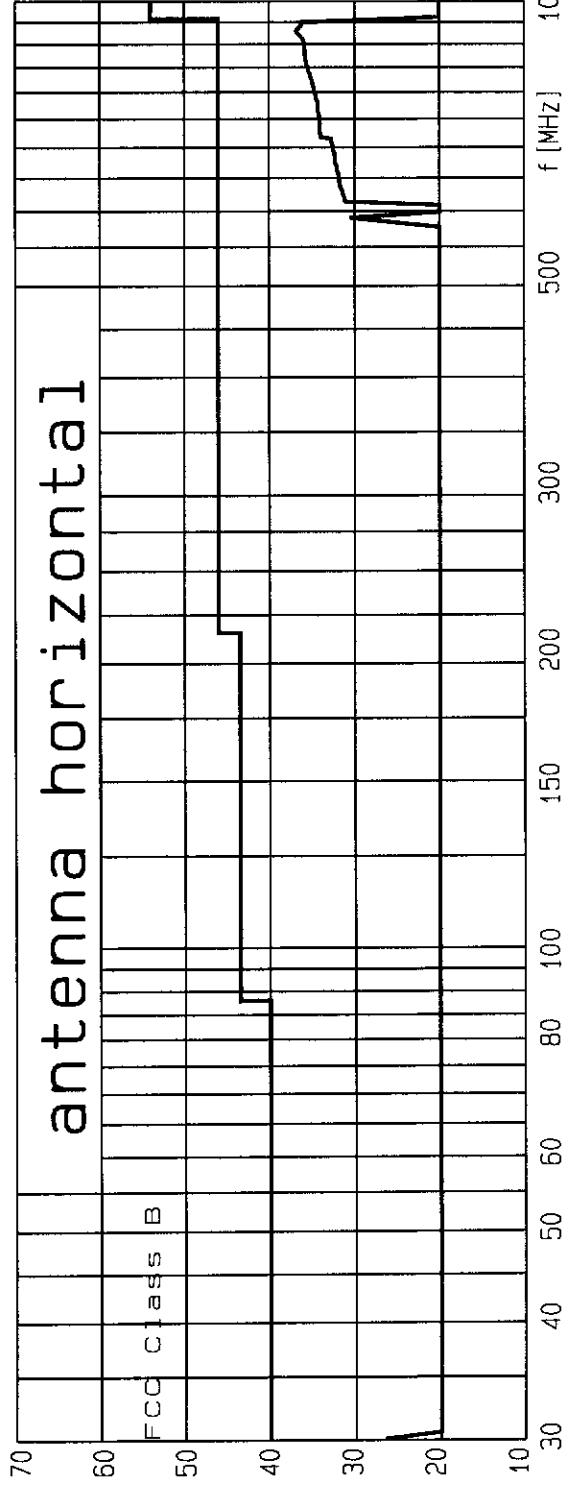
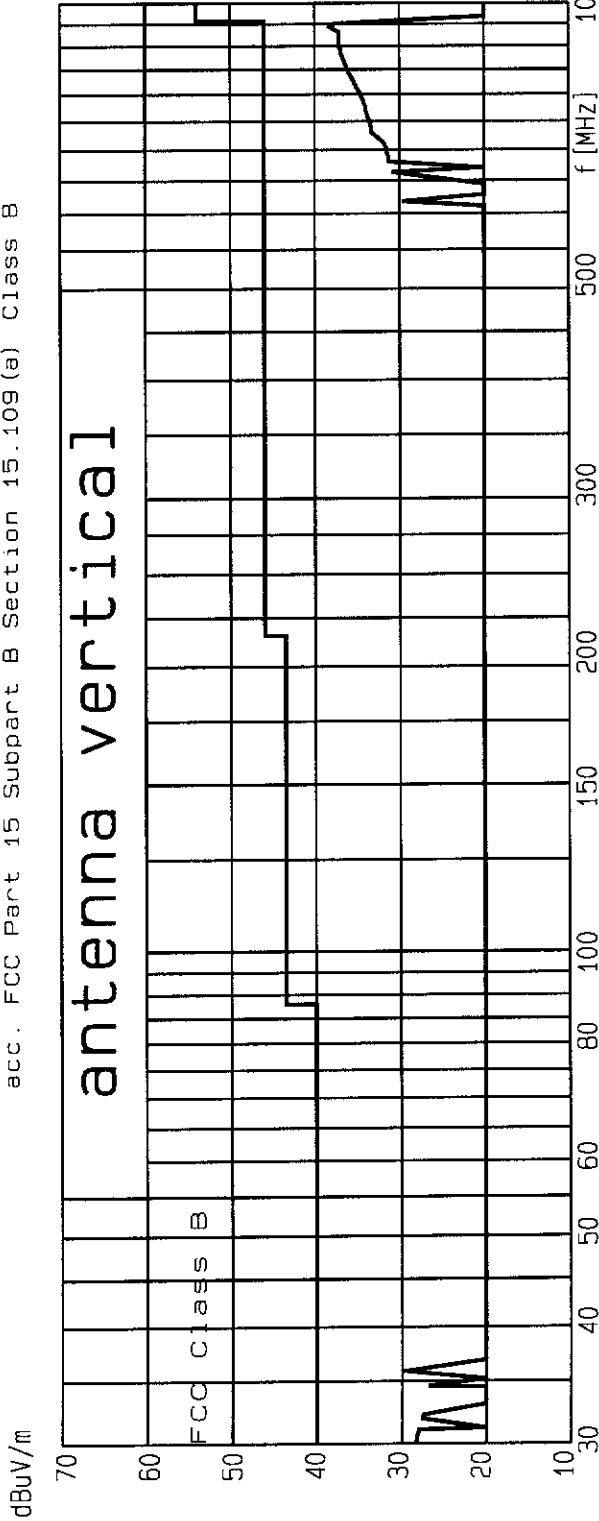

Result: pass fail

the highest points found:

freq. [MHz]	tested dBuV/m	limit dBuV/m	pol. h/v
941.92	38.18	46	v
950.44	37.64	46	v
902.76	37.16	46	v
930.56	37.14	46	v
888.28	36.9	46	v
928.04	36.82	46	h
942.96	36.2	46	h
949.12	36.19	46	h
909.56	35.98	46	h
885.6	35.79	46	h

* - IF ANY MEANS: EMISSION NOT COUNTED FOR JUDGEMENT



TESTED
IN GERMANY

Annex 1 / Test data
11/01-0105

Seite 6 von 12 Seiten
Page 6 of 12 pages



electronic GmbH
Frontenhausen

Ref.-No.: 11/01-0105
Product : SCANNER
Sample : 01
Date : 8 Feb 2011
Operator: BL

OPERATION MODE:
CARD READING

196	HOR.	FRQ.:	928.04	MHz	LEV.:	36.82	dBuV/m	Lim.:	46	dBuV/m
197	HOR.	FRQ.:	942.36	MHz	LEV.:	36.2	dBuV/m	Lim.:	46	dBuV/m
198	HOR.	FRQ.:	949.12	MHz	LEV.:	36.19	dBuV/m	Lim.:	46	dBuV/m
191	VER.	FRQ.:	844.36	MHz	LEV.:	36.03	dBuV/m	Lim.:	46	dBuV/m
192	VER.	FRQ.:	861.44	MHz	LEV.:	36.4	dBuV/m	Lim.:	46	dBuV/m
193	VER.	FRQ.:	884.08	MHz	LEV.:	36.87	dBuV/m	Lim.:	46	dBuV/m
194	VER.	FRQ.:	888.28	MHz	LEV.:	36.9	dBuV/m	Lim.:	46	dBuV/m
195	VER.	FRQ.:	902.76	MHz	LEV.:	37.16	dBuV/m	Lim.:	46	dBuV/m
196	VER.	FRQ.:	930.56	MHz	LEV.:	37.14	dBuV/m	Lim.:	46	dBuV/m
197	VER.	FRQ.:	941.92	MHz	LEV.:	38.18	dBuV/m	Lim.:	46	dBuV/m
198	VER.	FRQ.:	950.44	MHz	LEV.:	37.64	dBuV/m	Lim.:	46	dBuV/m



electronic GmbH
Frontenhausen

IT 5/6

Interference Radiation 30 MHz - 1000 MHz
acc. FCC Part 15 Subpart B Section 15.109(a) Class B

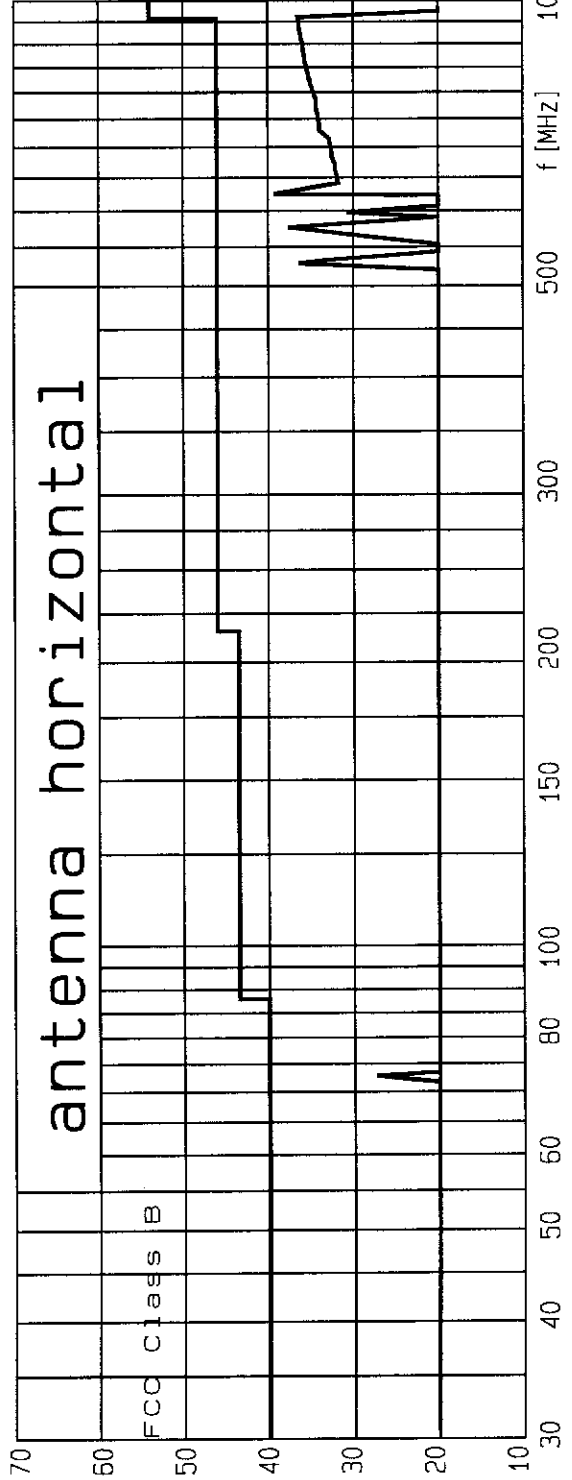
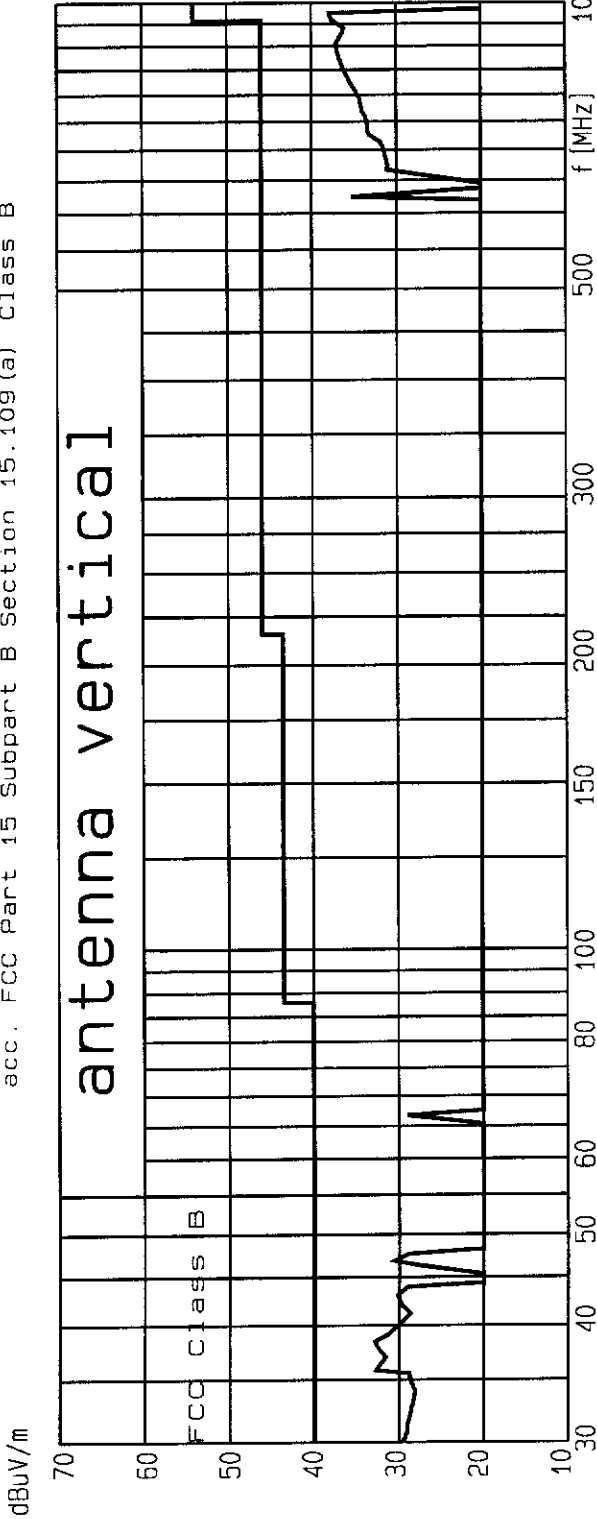

Ref.-No.: 11/01-0105
Product: SCANNER
Sample: 01
Date: 8 Feb 2011
Operator: BL

Test equipment:
Rohde & Schwarz ESVS
CHASE CBL 6111

Connected sets:
HOST COMPUTER
ALL CABLES

Operating mode:
USB-CONNECTED TO PC
CHARGE MODE

test distance 3m

RFI suppression parts:

Result: pass fail []

the highest points found:

freq. [MHz]	tested dBuV/m	limit dBuV/m	pol. h/v
38.4	32.9	40	v
35.8	32.7	40	v
37.96	32.6	40	v
37.64	32.3	40	v
959.24	37.66	46	v
624.12	39.3	46	h
576.12	37.6	46	h
959.32	36.46	46	h
588.12	36.4	46	h
937.16	36.3	46	h

* - IF ANY MEANS: EMISSION NOT COUNTED FOR JUDGEMENT



TESTED IN GERMANY

Annex 1 / Test data
11/01-0105

Seite 7 von 12 Seiten
Page 7 of 12 pages



TESTED
IN GERMANY

Annex 1 / Test data
11/01-0105

Seite 8 von 12 Seiten
Page 8 of 12 pages



pkM electronic GmbH
Frontenhausen

Ref.-No.: 11/01-0105
Product : SCANNER
Sample : 01
Date : 8 Feb 2011
Operator: BL

OPERATION MODE:
USB-CONNECTED TO PC
CHARGE MODE

164	HOR.	FRQ.:	528.12 MHz	LEV.:	36.4 dBuV/m	Lim.:	46 dBuV/m
169	HOR.	FRQ.:	576.12 MHz	LEV.:	37.6 dBuV/m	Lim.:	46 dBuV/m
174	HOR.	FRQ.:	624.12 MHz	LEV.:	39.3 dBuV/m	Lim.:	46 dBuV/m
195	HOR.	FRQ.:	914.72 MHz	LEV.:	36.11 dBuV/m	Lim.:	46 dBuV/m
196	HOR.	FRQ.:	923.8 MHz	LEV.:	36.22 dBuV/m	Lim.:	46 dBuV/m
197	HOR.	FRQ.:	937.16 MHz	LEV.:	36.3 dBuV/m	Lim.:	46 dBuV/m
198	HOR.	FRQ.:	959.32 MHz	LEV.:	36.46 dBuV/m	Lim.:	46 dBuV/m
11	VER.	FRQ.:	35.8 MHz	LEV.:	32.7 dBuV/m	Lim.:	40 dBuV/m
12	VER.	FRQ.:	37 MHz	LEV.:	31.6 dBuV/m	Lim.:	40 dBuV/m
13	VER.	FRQ.:	37.64 MHz	LEV.:	32.3 dBuV/m	Lim.:	40 dBuV/m
14	VER.	FRQ.:	37.96 MHz	LEV.:	32.6 dBuV/m	Lim.:	40 dBuV/m
15	VER.	FRQ.:	38.4 MHz	LEV.:	32.9 dBuV/m	Lim.:	40 dBuV/m
16	VER.	FRQ.:	39.04 MHz	LEV.:	31.4 dBuV/m	Lim.:	40 dBuV/m
21	VER.	FRQ.:	43 MHz	LEV.:	30.2 dBuV/m	Lim.:	40 dBuV/m
26	VER.	FRQ.:	46.8 MHz	LEV.:	30.5 dBuV/m	Lim.:	40 dBuV/m
191	VER.	FRQ.:	852.68 MHz	LEV.:	36.3 dBuV/m	Lim.:	46 dBuV/m
192	VER.	FRQ.:	858.92 MHz	LEV.:	36.39 dBuV/m	Lim.:	46 dBuV/m
193	VER.	FRQ.:	877.28 MHz	LEV.:	36.8 dBuV/m	Lim.:	46 dBuV/m
194	VER.	FRQ.:	897.88 MHz	LEV.:	37.07 dBuV/m	Lim.:	46 dBuV/m
195	VER.	FRQ.:	901.28 MHz	LEV.:	37.19 dBuV/m	Lim.:	46 dBuV/m
196	VER.	FRQ.:	930.52 MHz	LEV.:	36.31 dBuV/m	Lim.:	46 dBuV/m
197	VER.	FRQ.:	939.88 MHz	LEV.:	36.16 dBuV/m	Lim.:	46 dBuV/m
198	VER.	FRQ.:	959.24 MHz	LEV.:	37.66 dBuV/m	Lim.:	46 dBuV/m

