



# RADIO TEST REPORT

**Test Report No. : 13568152S-M**

**Applicant** : KONICA MINOLTA INC.  
**Type of EUT** : Wireless LAN SDIO module  
**Model Number of EUT** : SX-SDMAN2  
\*. The EUT was installed in the typical host device for testing.  
**Test regulation** : FCC Part 15 Subpart E: 2021  
**Test item** : DFS test \*Slave  
**Test result** : Complied (Refer to SECTION 3.2)

1. This test report shall not be reproduced in full or partial, without the written approval of UL Japan, Inc.
2. The results in this report apply only to the sample tested.
3. This sample tested is in compliance with the limits of the above regulation.
4. The test results in this test report are traceable to the national or international standards.
5. This test report must not be used by the customer to claim product certification, approval, or endorsement by the A2LA accreditation body.
6. This test report covers Radio technical requirements.  
It does not cover administrative issues such as Manual or non-Radio test related Requirements. (if applicable)
7. The all test items in this test report are conducted by UL Japan, Inc. Shonan EMC Lab.
8. The opinions and the interpretations to the result of the description in this report are outside scopes where UL Japan has been accredited.
9. The information provided from the customer for this report is identified in SECTION 1.

**Date of test:** January 22, 2021

**Representative test engineer:** K. Adachi  
Kenichi Adachi  
Engineer  
Consumer Technology Division

**Approved by:** T. Imamura  
Toyokazu Imamura  
Leader  
Consumer Technology Division



CERTIFICATE 1266.03

- The testing in which "Non-accreditation" is displayed is outside the accreditation scopes in UL Japan.  
 There is no testing item of "Non-accreditation".

**UL Japan, Inc.**  
**Shonan EMC Lab.**

1-22-3 Megumigaoka, Hiratsuka-shi, Kanagawa-ken, 259-1220, JAPAN  
Telephone : +81 463 50 6400  
Facsimile : +81 463 50 6401

## **REVISION HISTORY**

**Original Test Report No.: 13568152S-M**

Revision	Test report No.	Date	Page revised	Contents
- (Original)	13568152S-M	March 1, 2021	-	-

---

**UL Japan, Inc.**  
**Shonan EMC Lab.**

1-22-3 Megumigaoka, Hiratsuka-shi, Kanagawa-ken, 259-1220 JAPAN  
Telephone : +81 463 50 6400  
Facsimile : +81 463 50 6401

## Reference: Abbreviations (Including words undescribed in this report)

A2LA	The American Association for Laboratory Accreditation	MCS	Modulation and Coding Scheme
AC	Alternating Current	MRA	Mutual Recognition Arrangement
AFH	Adaptive Frequency Hopping	N/A	Not Applicable
AM	Amplitude Modulation	NIST	National Institute of Standards and Technology
Amp, AMP	Amplifier	NS	No signal detect.
ANSI	American National Standards Institute	NSA	Normalized Site Attenuation
Ant, ANT	Antenna	NVLAP	National Voluntary Laboratory Accreditation Program
AP	Access Point	OBW	Occupied Band Width
ASK	Amplitude Shift Keying	OFDM	Orthogonal Frequency Division Multiplexing
Atten., ATT	Attenuator	P/M	Power meter
AV	Average	PCB	Printed Circuit Board
BPSK	Binary Phase-Shift Keying	PER	Packet Error Rate
BR	Bluetooth Basic Rate	PHY	Physical Layer
BT	Bluetooth	PK	Peak
BT LE	Bluetooth Low Energy	PN	Pseudo random Noise
BW	BandWidth	PRBS	Pseudo-Random Bit Sequence
Cal Int	Calibration Interval	PSD	Power Spectral Density
CCK	Complementary Code Keying	QAM	Quadrature Amplitude Modulation
Ch., CH	Channel	QP	Quasi-Peak
CISPR	Comite International Special des Perturbations Radioelectriques	QPSK	Quadri-Phase Shift Keying
CW	Continuous Wave	RBW	Resolution Band Width
DBPSK	Differential BPSK	RDS	Radio Data System
DC	Direct Current	RE	Radio Equipment
D-factor	Distance factor	RF	Radio Frequency
DFS	Dynamic Frequency Selection	RMS	Root Mean Square
DQPSK	Differential QPSK	RSS	Radio Standards Specifications
DSSS	Direct Sequence Spread Spectrum	Rx	Receiving
EDR	Enhanced Data Rate	SA, S/A	Spectrum Analyzer
EIRP, e.i.r.p.	Equivalent Isotropically Radiated Power	SG	Signal Generator
EMC	ElectroMagnetic Compatibility	SVSWR	Site-Voltage Standing Wave Ratio
EMI	ElectroMagnetic Interference	TR	Test Receiver
EN	European Norm	Tx	Transmitting
ERP, e.r.p.	Effective Radiated Power	VBW	Video BandWidth
EU	European Union	Vert.	Vertical
EUT	Equipment Under Test	WLAN	Wireless LAN
Fac.	Factor		
FCC	Federal Communications Commission		
FHSS	Frequency Hopping Spread Spectrum		
FM	Frequency Modulation		
Freq.	Frequency		
FSK	Frequency Shift Keying		
GFSK	Gaussian Frequency-Shift Keying		
GNSS	Global Navigation Satellite System		
GPS	Global Positioning System		
Hori.	Horizontal		
ICES	Interference-Causing Equipment Standard		
IEC	International Electrotechnical Commission		
IEEE	Institute of Electrical and Electronics Engineers		
IF	Intermediate Frequency		
ILAC	International Laboratory Accreditation Conference		
ISED	Innovation, Science and Economic Development Canada		
ISO	International Organization for Standardization		
JAB	Japan Accreditation Board		
LAN	Local Area Network		
LIMS	Laboratory Information Management System		

## UL Japan, Inc. Shonan EMC Lab.

1-22-3 Megumigaoka, Hiratsuka-shi, Kanagawa-ken, 259-1220 JAPAN  
Telephone : +81 463 50 6400  
Facsimile : +81 463 50 6401

<b>CONTENTS</b>	<b>PAGE</b>
<b>SECTION 1: Customer information.....</b>	<b>5</b>
<b>SECTION 2: Equipment under test (EUT).....</b>	<b>5</b>
<b>SECTION 3: Scope of Report.....</b>	<b>6</b>
<b>SECTION 4: Test specification, procedures &amp; results.....</b>	<b>6</b>
<b>SECTION 5: Operation of EUT during testing.....</b>	<b>11</b>
<b>SECTION 6: Channel Move Time, Channel Closing Transmission Time.....</b>	<b>16</b>
<b>SECTION 7: Non-Occupancy Period.....</b>	<b>18</b>
<b>APPENDIX 1: Test instruments.....</b>	<b>20</b>
<b>APPENDIX 2: Photographs of test setup.....</b>	<b>21</b>

## **SECTION 1: Customer information**

Company Name : KONICA MINOLTA INC.  
Address : 1, Sakura-machi, Hino-shi, Tokyo, Japan 191-8511  
Telephone Number : +81-42-589-8429  
Facsimile Number : +81-42-589-8053  
Contact Person : Yukihiro Niekawa

The information provided from the customer is as follows;

- Applicant, Type of EUT, Model Number of EUT, FCC ID on the cover and other relevant pages
- Operating/Test Mode(s) (Mode(s)) on all the relevant pages
- SECTION 1: Customer information
- SECTION 2: Equipment under test (EUT) other than the Receipt Date
- SECTION 4: Operation of EUT during testing
- \* The laboratory is exempted from liability of any test results affected from the above information in SECTION 2 and 4.

## **SECTION 2: Equipment under test (EUT)**

### **2.1 Identification of EUT**

Type : Wireless LAN SDIO module  
Model Number : SX-SDMAN2  
Serial Number : Refer to SECTION 4.2  
Rating : DC 3.3 V, DC 1.8 V  
Receipt Date : June 17, 2016 and September 29, 2020  
Country of Mass-production : Japan  
Condition : Production prototype  
(Not for Sale: This sample is equivalent to mass-produced items.)  
Modification : No Modification by the test lab.

### **2.2 Product Description**

Model: SX-SDMAN2 (referred to as the EUT in this report) is a Wireless LAN SDIO module.

Clock frequency(ies) in the system : 26 MHz

### **Radio Specification**

Type of radio	IEEE802.11b	IEEE802.11g	IEEE802.11a	IEEE802.11n (20 M band)	IEEE802.11n (40 M band)
Frequency of operation	2412 MHz-2462 MHz	2412 MHz-2462 MHz	5180 MHz-5240 MHz 5260 MHz-5320 MHz 5500 MHz-5700 MHz 5745 MHz-5825 MHz	2412 MHz-2462 MHz 5180 MHz-5240 MHz 5260 MHz-5320 MHz 5500 MHz-5700 MHz 5745 MHz-5825 MHz	5190 MHz-5230 MHz 5270 MHz-5310 MHz 5510 MHz-5670 MHz 5755 MHz-5795 MHz
Type of modulation	DSSS (CCK, DQPSK, DBPSK)	OFDM-CCK (64QAM, 16QAM, QPSK, BPSK)	OFDM (64QAM, 16QAM, QPSK, BPSK)		
Channel spacing	5 MHz		20 MHz	2.4 GHz band 5 MHz 5 GHz band 20 MHz	40 MHz
Antenna type	[Main Antenna ( chain 0 )/Sub Antenna ( chain 1 )] PIFA (Planar Inverted F Antenna)				
Antenna Gain	Main Antenna ( chain 0 ) -1.95 dBi (2.4 GHz Band), -0.98 dBi (5 GHz Band) Sub Antenna ( chain 1 ) -2.21 dBi (2.4 GHz Band), -1.54 dBi (5 GHz Band)				
Antenna Connector type	[Main Antenna ( chain 0 )/Sub Antenna ( chain 1 )] Connector; PCB side: U.FL, Antenna side: soldered				

## **UL Japan, Inc. Shonan EMC Lab.**

1-22-3 Megumigaoka, Hiratsuka-shi, Kanagawa-ken, 259-1220 JAPAN  
Telephone : +81 463 50 6400  
Facsimile : +81 463 50 6401

### **SECTION 3: Scope of Report**

This report only covers DFS requirement, as specified by the following referenced procedures.

### **SECTION 4: Test specification, procedures & results**

#### **4.1 Test Specification**

Test Specification	:	FCC Part 15 Subpart E FCC Part 15 final revised on January 12, 2021 and effective February 11, 2021  * The revision does not affect the test result conducted before its effective date.
Title	:	FCC 47CFR Part15 Radio Frequency Device Subpart E Unlicensed National Information Infrastructure Devices Section 15.407 General technical requirements
Test Specification	:	KDB905462 D02 UNII DFS Compliance Procedures New Rules v02
Title	:	COMPLIANCE MEASUREMENT PROCEDURES FOR UNLICENSED- NATIONAL INFORMATION INFRASTRUCTURE DEVICES OPERATING IN THE 5250-5350MHz AND 5470-5725MHz BANDS INCORPORATING DYNAMIC FREQUENCY SELECTION
Test Specification	:	KDB905462 D03 Client Without DFS New Rules v01r02
Title	:	U-NII CLIENT DEVICES WITHOUT RADAR DETECTION CAPABILITY

#### **FCC Part 15.31 (e)**

The RF Module has its own regulator.

The RF Module is constantly provided voltage through the regulator regardless of input voltage. Therefore, this EUT complies with the requirement.

#### **FCC Part 15.203/212 Antenna requirement**

The EUT has a unique coupling/antenna connector. Therefore the equipment complies with the requirement.

## 4.2 Procedures and results

**Table 1: Applicability of DFS Requirements**

Requirement	Operating Mode	Test Procedures & Limits	Deviation	Results
	Client without Radar Detection			
U-NII Detection Bandwidth	Not required	KDB905462 D02 UNII DFS Compliance Procedures New Rules v02	N/A	N/A
Initial Channel Availability Check Time	Not required	FCC15.407 (h)	N/A	N/A
		KDB905462 D02 UNII DFS Compliance Procedures New Rules v02		
		RSS-247 6.3		
Radar Burst at the Beginning of the Channel Availability Check Time	Not required	FCC15.407 (h)	N/A	N/A
		KDB905462 D02 UNII DFS Compliance Procedures New Rules v02		
		RSS-247 6.3		
Radar Burst at the End of the Channel Availability Check Time	Not required	FCC15.407 (h)	N/A	N/A
		KDB905462 D02 UNII DFS Compliance Procedures New Rules v02		
		RSS-247 6.3		
In-Service Monitoring for Channel Move Time, Channel Closing Transmission Time	Yes	FCC15.407 (h)	N/A	Complied a)
		KDB905462 D02 UNII DFS Compliance Procedures New Rules v02		
		RSS-247 6.3		
In-Service Monitoring for Non-Occupancy period	Yes *	FCC15.407 (h)	N/A	Complied b)
		KDB905462 D02 UNII DFS Compliance Procedures New Rules v02		
		RSS-247 6.3		
Statistical Performance Check	Not required	FCC15.407 (h)	N/A	N/A
		KDB905462 D02 UNII DFS Compliance Procedures New Rules v02		
Note: UL Japan, Inc.'s EMI Work Procedures No. 13-EM-W0422.				
a) Refer to SECTION 6, clause 6.3				
b) Refer to SECTION 7, clause 7.3				
Symbols:				
Complied The data of this test item has enough margin, more than the measurement uncertainty.				
Complied# The data of this test item meets the limits unless the measurement uncertainty is taken into consideration.				

\*Although this test was not required in FCC, KDB 905462 D02, it was performed as additional test.

## UL Japan, Inc. Shonan EMC Lab.

1-22-3 Megumigaoka, Hiratsuka-shi, Kanagawa-ken, 259-1220 JAPAN  
Telephone : +81 463 50 6400  
Facsimile : +81 463 50 6401

**Table 2 DFS Detection Thresholds for Master Devices and Client Devices With Radar Detection**

Maximum Transmit Power	Value (See Notes 1,2, and 3)
≥ 200 milliwatt	-64 dBm
< 200 milliwatt and power spectral density < 10 dBm/MHz	-62 dBm
< 200 milliwatt that do not meet the power spectral density requirement	-64 dBm
<p>Note 1: This is the level at the input of the receiver assuming a 0 dBi receive antenna.</p> <p>Note 2: Throughout these test procedures an additional 1 dB has been added to the amplitude of the test transmission waveforms to account for variations in measurement equipment. This will ensure that the test signal is at or above the detection threshold level to trigger a DFS response.</p> <p>Note 3: EIRP is based on the highest antenna gain. For MIMO devices refer to KDB Publication 662911 D01.</p>	

**Table 3 DFS Response Requirement Values**

Parameter	Value
Non-occupancy period	Minimum 30 minutes
Channel Availability Check Time	60 seconds
Channel Move Time	10 seconds See Note 1
Channel Closing Transmission Time	200 milliseconds + an aggregate of 60 milliseconds over remaining 10 second period. See Notes 1 and 2
U-NII Detection Bandwidth	Minimum 100 % of the U-NII 99 % transmission power bandwidth See Note 3
<p><b>Note 1:</b> Channel Move Time and the Channel Closing Transmission Time should be performed with Radar Type 0. The measurement timing begins at the end of the Radar Type 0 burst.</p> <p><b>Note 2:</b> The Channel Closing Transmission Time is comprised of 200 milliseconds starting at the beginning of the Channel Move Time plus any additional intermittent control signals required to facilitate a Channel move (an aggregate of 60 milliseconds) during the remainder of the 10 second period. The aggregate duration of control signal will not count quiet periods in between transmissions.</p> <p><b>Note 3:</b> During the U-NII Detection Bandwidth detection test, radar type 0 should be used. For each frequency step the minimum percentage of detection is 90 percent. Measurements are performed with no data traffic.</p>	



**Table 4 Short Pulse Radar Test Waveform**

Radar Type	Pulse Width (μsec)	PRI (μsec)	Number of Pulses	Minimum Percentage of Successful Detection	Minimum Number of Trials
0	1	1428	18	See Note 1	See Note 1
1	1	Test A: 15 unique PRI values randomly selected from the list of 23 PRI values in Table 5a	Roundup{(1/360)* (19*10 <sup>6</sup> /PRI μsec)}	60 %	30
		Test B: 15 unique PRI values randomly selected within the range of 518-3066 μsec, with a minimum increment of 1 μsec, excluding PRI values selected in Test A			
2	1-5	150-230	23-29	60 %	30
3	6-10	200-500	16-18	60 %	30
4	11-20	200-500	12-16	60 %	30
Aggregate (Rader Types 1-4)				80 %	120
Note 1: Short Pulse Radar Type 0 should be used for the detection bandwidth test, channel move time, and channel closing time tests.					

**Table 5 Long Pulse Radar Test Waveform**

Radar Type	Pulse Width (μsec)	Chip Width (MHz)	PRI (μsec)	Number of Pulses per Burst	Number of Burst	Minimum Percentage of Successful Detection	Minimum Number of Trials
5	50-100	5 - 20	1000-2000	1-3	8-20	80 %	30

**Table 6 Frequency Hopping Radar Test Waveform**

Radar Type	Pulse Width (μsec)	PRI (μsec)	Pulse per Hop (kHz)	Hopping Rate (kHz)	Hopping Sequence Length (msec)	Minimum Percentage of Successful Detection	Minimum Number of Trials
6	1	333	9	0.333	300	70 %	30

**4.3 Addition to standard**

No addition, exclusion nor deviation has been made from the standard.

**UL Japan, Inc.  
Shonan EMC Lab.**

1-22-3 Megumigaoka, Hiratsuka-shi, Kanagawa-ken, 259-1220 JAPAN  
Telephone : +81 463 50 6400  
Facsimile : +81 463 50 6401

#### 4.4 Test Location

UL Japan, Inc. Shonan EMC Lab.

1-22-3, Megumigaoka, Hiratsuka-shi, Kanagawa-ken 259-1220 JAPAN

Telephone: +81 463 50 6400, Facsimile: +81 463 50 6401

A2LA Certificate Number: 1266.03

(FCC test firm registration number: 626366, ISED lab company number: 2973D / CAB identifier: JP0001)

Test site	IC Registration Number	Width x Depth x Height (m)	Size of reference ground plane (m) / horizontal conducting plane	Maximum measurement distance
No.1 Semi-anechoic chamber	2973D-1	20.6 x 11.3 x 7.65	20.6 x 11.3	10 m
No.2 Semi-anechoic chamber	2973D-2	20.6 x 11.3 x 7.65	20.6 x 11.3	10 m
No.3 Semi-anechoic chamber	2973D-3	12.7 x 7.7 x 5.35	12.7 x 7.7	5 m
No.4 Semi-anechoic chamber	-	8.1 x 5.1 x 3.55	8.1 x 5.1	-
No.1 Shielded room	-	6.8 x 4.1 x 2.7	6.8 x 4.1	-
No.2 Shielded room	-	6.8 x 4.1 x 2.7	6.8 x 4.1	-
No.3 Shielded room	-	6.3 x 4.7 x 2.7	6.3 x 4.7	-
No.4 Shielded room	-	4.4 x 4.7 x 2.7	4.4 x 4.7	-
No.5 Shielded room	-	7.8 x 6.4 x 2.7	7.8 x 6.4	-
No.6 Shielded room	-	7.8 x 6.4 x 2.7	7.8 x 6.4	-
No.8 Shielded room	-	3.45 x 5.5 x 2.4	3.45 x 5.5	-
No.1 Measurement room	-	2.55 x 4.1 x 2.5	-	-

#### 4.5 Uncertainty

The following uncertainties have been calculated to provide a confidence level of 95% using a coverage factor  $k=2$ .  
Time Measurement uncertainty for this test was: ( $\pm$ ) 0.012%

#### 4.6 Test instruments of DFS and Test set up

Refer to APPENDIX.

---

#### UL Japan, Inc. Shonan EMC Lab.

1-22-3 Megumigaoka, Hiratsuka-shi, Kanagawa-ken, 259-1220 JAPAN

Telephone : +81 463 50 6400

Facsimile : +81 463 50 6401

## **SECTION 5: Operation of EUT during testing**

### **5.1 Operating Modes**

The EUT, which is a Client Device without Radar detection capability, operates over the W53 and W56 Band.

The channel-loading of approximately 17 % or greater was used for testing, and its test data was transferred from the Master Device to the Client Device for all test configurations.

WLAN traffic is generated random data by ExPing.exe program from the Master to the Client.

The EUT utilizes the 802.11a/n architecture, with a 20 MHz and 40 MHz channel bandwidth.

The FCC ID for the Master Device used with EUT for DFS testing is LDK102073.

The rated output power of the Master unit is >200 mW (23 dBm). Therefore the required interference threshold level is -64 dBm. After correction for antenna gain and procedural adjustments, the required conducted threshold at the antenna port is  $-64 + 1 + 4 = -59.0$  dBm (threshold level + additional 1 dB + antenna gain).

It is impossible for users to change DFS control, because the DFS function is written on the firmware and users cannot access it.

The EUT was set by the software as follows:

Software name & version:

ExPing.exe ver.1.3 (for Master device)

(Date: 2017.4.18, Storage location: Driven by connected PC)

Wireless authentication test tool Version 1.3.0.3 (for EUT)

(Date: 2017.4.18, Storage location: Driven by connected PC)

## 5.2 Configuration and peripherals

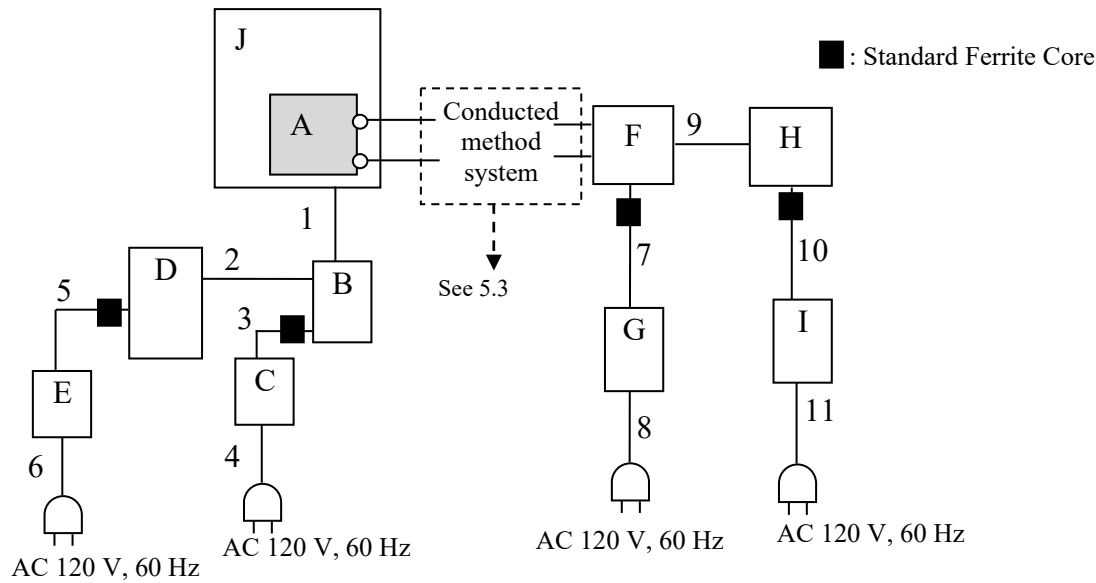

### Description of EUT and Support equipment

No.	Item	Model number	Serial number	Manufacturer	Remarks
A	Wireless LAN SDIO module	SX-SDMAN2	A9YH-S002	KONICA MINOLTA INC.	EUT
B	Battery Charging Unit	AeroDR	A7R9-00078	KONICA MINOLTA INC.	-
C	AC Adapter	TR60M48	60480-0000095	ELECTRONICS CO., LTD.	-
D	Laptop Computer	7666-77J	LV-B8PVT 08/05	Lenovo	-
E	AC Adapter	42T4422	11S42T4422Z1ZF3 D9BV4XN	Lenovo	-
F	Wireless LAN access point (Master device)	AIR-CAP3702E-A-K9	FTX18227609	Cisco systems	FCC ID: LDK102073, ISED No. 2461B-102073
G	AC Adapter	EADP-18MB	DAB1528MANP	Cisco systems	-
H	Laptop Computer	DELL Vostro V1510	29090510205	DELL	-
I	AC Adapter	LA65NS1-00	71615-93B-385D	DELL	-
J	SKR 3000	P-75	A9YH-S002	KONICA MINOLTA INC.	-

### List of cables used

No.	Cable name	Length (m)	Shield		Remarks
			Cable	Connector	
1	IO cable	10.0	Shielded	Shielded	-
2	LAN cable	10.0	Unshielded	Unshielded	-
3	DC cable	1.5	Unshielded	Unshielded	-
4	AC cable	3.0	Unshielded	Unshielded	-
5	DC cable	1.8	Unshielded	Unshielded	-
6	AC cable	0.9	Unshielded	Unshielded	-
7	DC cable	1.8	Unshielded	Unshielded	-
8	AC cable	2.0	Unshielded	Unshielded	-
9	LAN cable	1.0	Unshielded	Unshielded	-
10	DC cable	1.8	Unshielded	Unshielded	-
11	AC cable	0.7	Unshielded	Unshielded	-

### UL Japan, Inc. Shonan EMC Lab.

1-22-3 Megumigaoka, Hiratsuka-shi, Kanagawa-ken, 259-1220 JAPAN  
Telephone : +81 463 50 6400  
Facsimile : +81 463 50 6401

### 5.3 Test and Measurement System

#### SYSTEM OVERVIEW

The measurement system is based on a conducted test method.

The software selects waveform parameters from within the bounds of the signal type on a random basis using uniform distribution. The short pulse types 1, 2, 3, and 4, the long pulse type 5, and the frequency hopping type 6 parameters are randomized at run-time.

The signal monitoring equipment consists of a spectrum analyzer with the capacity to display 8001 bins on the horizontal axis. A time-domain resolution of 2 ms/bin is achievable with a 16 second sweep time, meeting the 10 seconds short pulse reporting criteria. The aggregate ON time is calculated by multiplying the number of bins above a threshold during a particular observation period by the dwell time per bin, with the analyzer set to peak detection.

#### FREQUENCY HOPPING RADAR WAVEFORM GENERATING SUBSYSTEM

The first 100 frequencies are selected out of the hopping sequence of the randomized 475 hop frequencies. Only a *Burst* that has the frequency falling within the receiver bandwidth of the tested U-NII device is selected among those frequencies. (Frequency-domain simulation). The radar waveform generated at the start time of the selected *Burst* (Time-domain simulation) is download to the Signal Generator. If all of the randomly selected 100 frequencies do not fall within the receiver bandwidth of the U-NII device, the radar waveform is not used for the test.

#### CONDUCTED METHODS SYSTEM BLOCK DIAGRAM

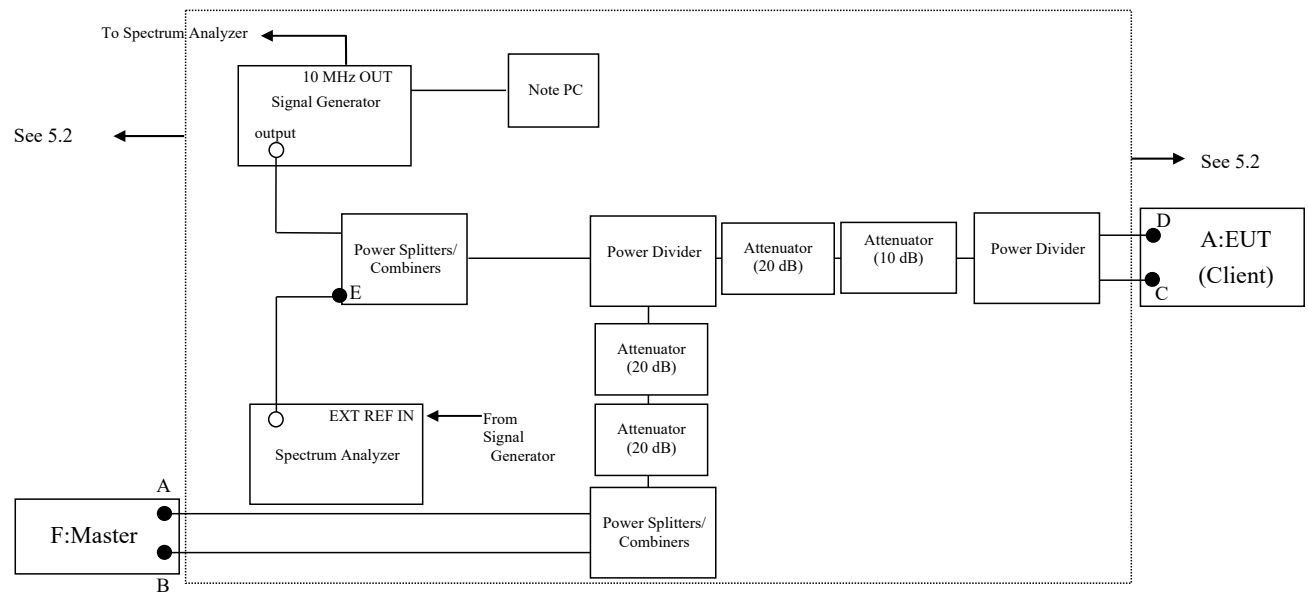

#### MEASUREMENT SYSTEM FREQUENCY REFERENCE

Lock the signal generator and the spectrum analyzer to the same reference sources as follows: Connect the 10 MHz OUT on the signal generator to the EXT REF IN on the spectrum analyzer and set the spectrum analyzer Ext to On.

## **SYSTEM CALIBRATION**

**Step 1:** Set the system as shown in Figure 3 of KDB905462 D02 7.2.2.

**Step 2:** Adjust each attenuator to fulfill the following three conditions:

- WLAN can be communicated, and
- Rader detection threshold level is bigger than Client Device traffic level on the spectrum analyzer, and
- Master Device traffic level is not displayed on the spectrum analyzer.

**Step 3:** Terminate 50 ohm at B, C, D and E points, and connect the spectrum analyzer to the point A. (See the figure of CONDUCTED METHODS SYSTEM BLOCK DIAGRM on Section 5, Clause 3)

At the point A, adjust the signal generator and spectrum analyzer to the center frequency of the channel to be measured.

Download the applicable radar waveforms to the signal generator. Select the radar waveform, trigger a burst manually and measure the amplitude on the spectrum analyzer. Readjust the amplitude of the signal generator as required so that the peak level of the waveform is at a displayed level equal to the required or desired interference detection threshold.

Separate signal generator amplitude settings are determined as required for each radar type.

**Step 4:** Without changing any of the instrument settings, restore the system setting to Step 2 and adjust the Reference Level Offset of the spectrum analyzer to the level at Step 3.

By taking the above steps 1 to 4, the spectrum analyzer displays the level of the signal generator as received at the antenna ports of the Master Device.

See Clause 5.4 for Plots of Noise, Rader Waveforms, and WLAN signals.

5.4 Plots of Noise, Rader Waveforms, and WLAN signals

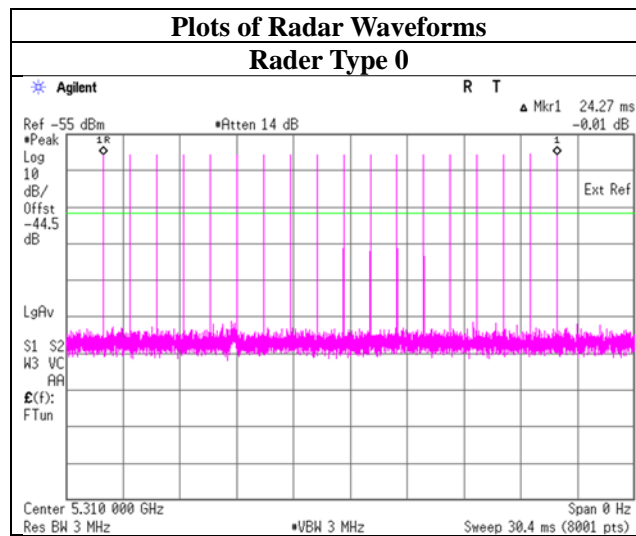
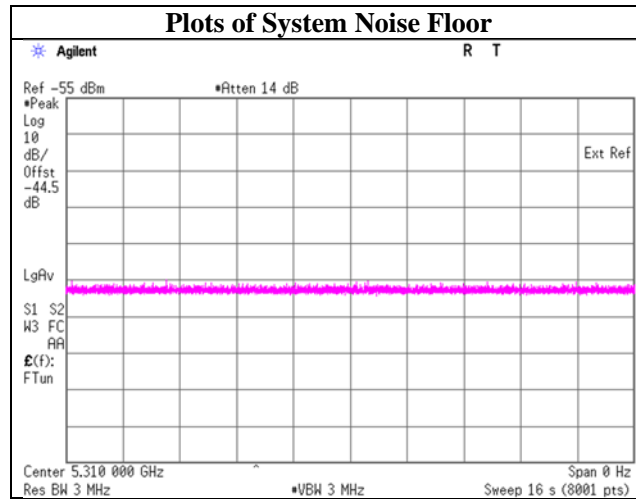

**UL Japan, Inc.**  
**Shonan EMC Lab.**

1-22-3 Megumigaoka, Hiratsuka-shi, Kanagawa-ken, 259-1220 JAPAN  
Telephone : +81 463 50 6400  
Facsimile : +81 463 50 6401

## **SECTION 6: Channel Move Time, Channel Closing Transmission Time**

### **6.1 Operating environment**

Report No. 13568152S-M  
Test place Shonan EMC Lab. No.5 Shielded Room  
Date January 22, 2021  
Temperature / Humidity 24 deg. C / 41 % RH  
Engineer Kenichi Adachi  
Mode 11n-40

### **6.2 Test Procedure**

Transmit the data from the Master Device to the Client Device on the test Channel for the entire period of the test. The Radar Waveform generator sends a Burst of pulses for one of the Short Pulse Radar Types 0 at levels defined , on the Operating Channel. An additional 1 dB is added to the radar test signal to ensure it is at or above the DFS Detection Threshold, accounting for equipment variations/errors.

Observe the transmissions of the EUT at the end of the radar Burst on the Operating Channel for duration greater than 10 seconds.

### **6.3 Test data**

#### **11ac-80**

Test Item	Unit	Measurement Time	Limit	Results
Channel Move Time *1)	[s]	0.012	10.000	Pass
Channel Closing Transmission Time *2)	[ms]	0	60	Pass

\*1) Channel Move Time is calculated as follows:

$$(\text{Channel Move Time}) = (\text{End of Transmission}) - (\text{End of Burst}) = 0.712 - 0.7$$

\*2) Channel Closing Transmission Time is calculated from (End of Burst + 200 ms) to (End of Burst + 10 s)

$$(\text{Channel Closing Transmission Time}) = (\text{Number of analyzer bins showing transmission}) \times (\text{dwell time per bin}) \\ = 0 \times 2 \text{ [ms]}$$



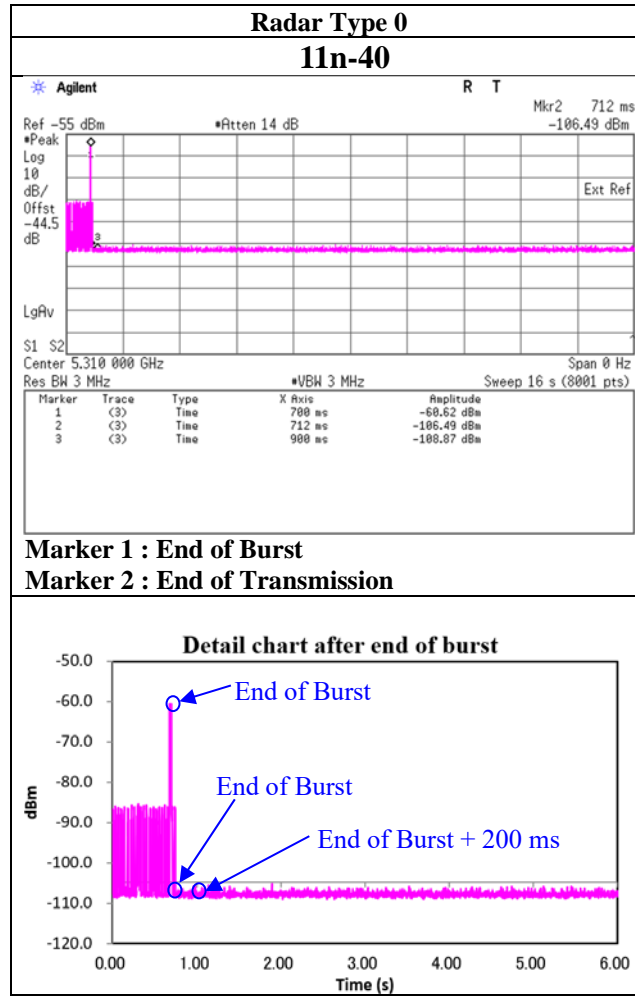

**6.4 Test result**

Test result: Pass

## **SECTION 7: Non-Occupancy Period**

### **7.1 Operating environment**

Report No.	13568152S-M
Test place	Shonan EMC Lab. No.5 Shielded Room
Date	January 22, 2021
Temperature / Humidity	24 deg. C / 41 % RH
Engineer	Kenichi Adachi
Mode	11n-40

### **7.2 Test Procedure**

The following two tests are performed:

- 1). Transmit the data from the Master Device to the Client Device on the test Channel for the entire period of the test. The Radar Waveform generator sends a Burst of pulses for one of the Radar Types 0 at levels defined on the Operating Channel. An additional 1 dB is added to the radar test signal to ensure it is at or above the DFS Detection Threshold, accounting for equipment variations/errors. Observe the transmissions of the EUT after the Channel Move Time on the Operating Channel for duration greater than 30 minutes.
- 2). Transmit the data from the Master Device to the Client Device on the test Channel for the entire period of the test. Observe the transmissions of the EUT on the Operating Channel for duration greater than 30 minutes after the Master Device is shut off.

7.3 Test data

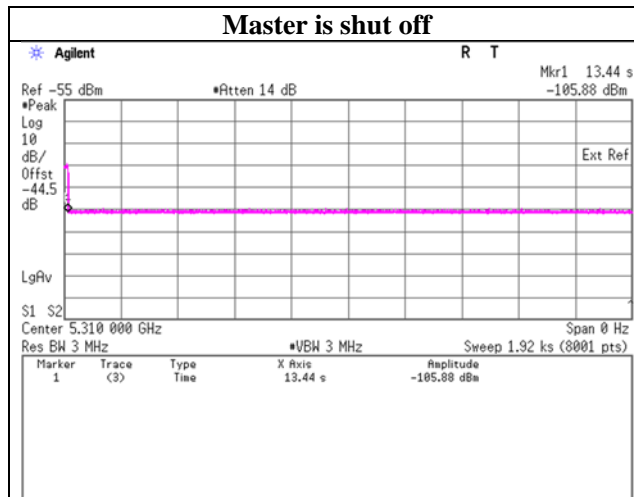
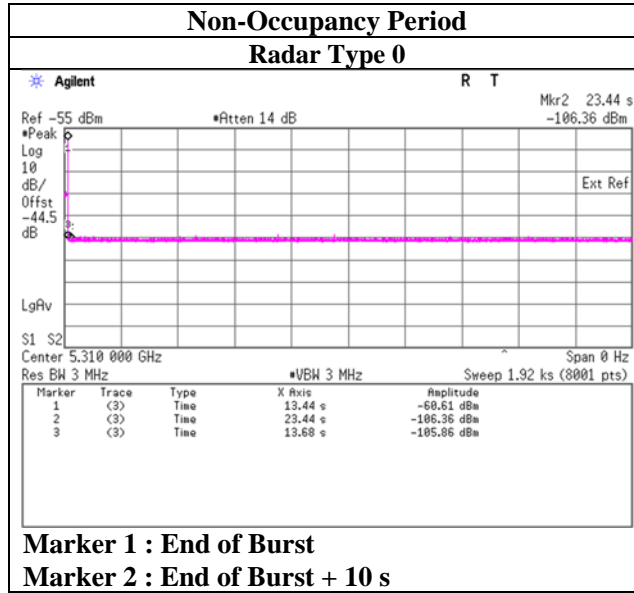

7.4 Test result

Test result: Pass

## APPENDIX 1: Test instruments

### Test equipment

Test Name	Local ID	LIMS ID	Description	Manufacturer	Model	Serial	Last Calibration Date	Calibration Interval (Month)
DFS	COTS-SDFS-01	144863	Signal Studio Software for DFS	Keysight Technologies Inc	N7620A-101	5010-7739	-	12
DFS	KAT10-S2	144892	Attenuator	Keysight Technologies Inc	8490D 010	6036	2020/10/05	12
DFS	SAT20-06	145146	Attenuator	Weinschel Corp.	54A-20	31506	2020/04/01	12
DFS	SAT20-07	145155	Attenuator	Weinschel Corp.	54A-20	31484	2020/04/01	12
DFS	SAT20-12	160495	Attenuator	Weinschel Corp.	54A-20	86752	2020/12/21	12
DFS	SCC-G24	145181	Coaxial Cable	Suhner	141PE	-	2020/07/15	12
DFS	SCC-G25	145182	Coaxial Cable	Suhner	141PE	-	2020/07/15	12
DFS	SCC-G37	151614	Coaxial Cable	Junkosha	MWX241-01000KMSKMS/B	1612Q035	2020/12/21	12
DFS	SCC-G38	151615	Coaxial Cable	Junkosha	MWX241-01000KMSKMS/B	1612Q036	2020/12/21	12
DFS	SCC-G39	151616	Coaxial Cable	Junkosha	MWX241-01000KMSKMS/B	1612Q037	2020/12/21	12
DFS	SCC-G61	196937	Coaxial Cable	HUBER+SUNER	SUCOFLEX 102	803605/2	2020/03/10	12
DFS	SOS-19	175823	Humidity Indicator	CUSTOM. Inc	CTH-201	-	2020/10/01	12
DFS	SPSC-02	146252	Power Splitters/Combiners	Mini-Circuits	ZFSC-2-10G+	-	2020/11/19	12
DFS	SPSC-03	146253	Power Splitters/Combiners	Mini-Circuits	ZFSC-2-10G+	-	2020/11/19	12
DFS	SPSC-07	146276	Power Splitters/Combiners	Mini-Circuits	ZFSC-2-10G+	-	2020/11/19	12
DFS	SPSC-08	146277	Power Splitters/Combiners	Mini-Circuits	ZFSC-2-10G+	-	2020/11/19	12
DFS	SRE-157	145693	Wireless LAN access point	Cisco Systems	AIR-CAP3702E-A-K9	FTX18227609	-	12
DFS	SSA-03	145801	Spectrum Analyzer	Keysight Technologies Inc	E4448A	MY48250152	2020/08/12	12
DFS	SSG-01	145804	Signal Generator	Keysight Technologies Inc	E4438C	MY47271584	2020/04/16	12
DFS	STS-05	146212	Digital Hitester	HIOKI E.E. CORPORATION	3805-50	80997828	2020/10/19	12

\*Hyphens for Last Calibration Date and Cal Int (month) are instruments that Calibration is not required (e.g. software), or instruments checked in advance before use.

\*1) Signal generator is only used to generate radar test signal, and the wave form is confirmed with spectrum analyzer every time before the test.

The expiration date of the calibration is the end of the expired month.

As for some calibrations performed after the tested dates, those test equipment have been controlled by means of an unbroken chains of calibrations.

All equipment is calibrated with valid calibrations. Each measurement data is traceable to the national or international standards.

Test item:

DFS: Dynamic Frequency Selection

**UL Japan, Inc.**

**Shonan EMC Lab.**

1-22-3 Megumigaoka, Hiratsuka-shi, Kanagawa-ken, 259-1220 JAPAN

Telephone : +81 463 50 6400

Facsimile : +81 463 50 6401