



EMI TEST REPORT

Test Report No. : 31HE0102-SH-04-C

Applicant : KONICA MINOLTA MEDICAL & GRAPHIC, INC.
Type of Equipment : AeroDR SYSTEM
Model No. : AeroDR P-21
FCC ID : YR7AERODRP2
Test regulation : FCC Part 15 Subpart E: 2011
Section 15.407(DFS test only)
Test Result : Complied

1. This test report shall not be reproduced in full or partial, without the written approval of UL Japan, Inc.
2. The results in this report apply only to the sample tested.
3. This sample tested is in compliance with above regulation.
4. The test results in this report are traceable to the national or international standards.

Date of test : June 9, 2010

Representative test engineer:

Tatsuya Arai
Engineer of EMC Service

Approved by :

Toyokazu Imamura
Assistant Manager of WiSE Japan, UL
Verification Service

UL Japan, Inc.

Shonan EMC Lab.

1-22-3 Megumigaoka, Hiratsuka-shi, Kanagawa-ken, 259-1220 JAPAN

Telephone: +81 463 50 6400

Facsimile: +81 463 50 6401

CONTENTS	PAGE
SECTION 1: Customer information.....	3
SECTION 2: Equipment under test (E.U.T.).....	3
SECTION 3: Scope of Report.....	4
SECTION 4: Test specification, procedures & results.....	4
SECTION 5: Operation of E.U.T. during testing.....	9
SECTION 6: In-Service Monitoring for Channel Move Time, Channel Closing Transmission Time.....	16
SECTION 7: In-Service Monitoring for Non-Occupancy Period.....	19
APPENDIX 1: Photographs of test setup.....	21
APPENDIX 2: Data of DFS test.....	22
Parameter Data for Radar Type 5.....	22
APPENDIX 3: Test instruments.....	23

UL Japan, Inc.

Shonan EMC Lab.

1-22-3 Megumigaoka, Hiratsuka-shi, Kanagawa-ken, 259-1220 JAPAN

Telephone: +81 463 50 6400

Facsimile: +81 463 50 6401

SECTION 1: Customer information

Company Name : KONICA MINOLTA MEDICAL & GRAPHIC, INC
Address : 1 Sakura-Machi, Hino-Shi, Tokyo, 191-8511 Japan
Telephone Number : +81-42-589-8429
Facsimile Number : +81-42-589-8053
Contact Person : Masayoshi Inoue

SECTION 2: Equipment under test (E.U.T.)

2.1 Identification of E.U.T.

Type of Equipment : AeroDR SYSTEM
Model No. : AeroDR P-21
Serial No. : Refer to Section5
Rating : DC15V
Country of Mass-production : Japan
Condition of EUT : Engineering prototype
(Not for Sale: This sample is equivalent to mass-produced items.)
Modification of EUT : No modification by the test lab.
Receipt Date of Sample : May 25, 2010 (Wireless LAN board only)

2.2 Product description

Model: AeroDR P-21 (referred to as the EUT in this report) is a AeroDR SYSTEM.

Equipment type : Transceiver
Frequency of operation : 5180-5320MHz
5500-5700MHz
5745-5825MHz
Clock frequency : 32.768kHz, 26MHz
Bandwidth & channel spacing : Bandwidth : 18MHz
Channel spacing : 20MHz
Type of modulation : 11a : OFDM
Antenna type : Planar Inverted F Antenna
Antenna gain with cable loss : +3.78dBi
Antenna connector type : U.FL
ITU code : D1D, G1D
Operation temperature range : +10 to +30 deg.C.

*) Equipment couldn't play movie picture therefore, test has been conducted with single body of WLAN board.

FCC Part15.31 (e)

This EUT provides stable voltage (DC3.3V) constantly to RF part regardless of input voltage. Therefore, this EUT complies with the requirement.

FCC Part15.203 Antenna requirement

It is impossible for end users to replace the antenna, because the antenna is mounted inside of the EUT. Therefore, the equipment complies with the antenna requirement of Section 15.203.

UL Japan, Inc.
Shonan EMC Lab.

1-22-3 Megumigaoka, Hiratsuka-shi, Kanagawa-ken, 259-1220 JAPAN
Telephone: +81 463 50 6400
Facsimile: +81 463 50 6401

SECTION 3: Scope of Report

The EUT has the channels from 5180 to 5320MHz and 5500 to 5700MHz.

This report only covers DFS requirement subject to 5250-5350MHz and 5500 to 5700MHz bands, as specified by the following referenced procedures.

SECTION 4: Test specification, procedures & results

4.1 Test Specification

Test Specification : FCC Part 15 Subpart E: 2011, final revised on July 8, 2011
and effective August 8, 2011

Title : FCC 47CFR Part15 Radio Frequency Device
Subpart E Unlicensed National Information Infrastructure Devices
Section 15.407 General technical requirements

*The revision on July 8, 2011 does not affect the test specification applied to the EUT.

Test Specification : FCC 06-96 APPENDIX
Title : COMPLIANCE MEASUREMENT PROCEDURES FOR UNLICENSED-
NATIONAL INFORMATION INFRASTRUCTURE DEVICES
OPERATING IN THE 5250-5350 MHz AND 5470-5725MHz BANDS
INCORPORATING DYNAMIC FREQUENCY SELECTION

4.2 Procedures and results

Table 1: Applicability of DFS Requirements

Requirement	Operating Mode	Test Procedures & Limits	Deviation	Results
	Client without Radar Detection			
U-NII Detection Bandwidth	Not required	FCC 06-96 Appendix 7.8.1	N/A	N/A
Initial Channel Availability Check Time	Not required	FCC15.407 (h)	N/A	N/A
		FCC 06-96 Appendix 7.8.2.1		
		RSS-210 A9.3		
Radar Burst at the Beginning of the Channel Availability Check Time	Not required	FCC15.407 (h)	N/A	N/A
		FCC 06-96 Appendix 7.8.2.2		
		RSS-210 A9.3		
Radar Burst at the End of the Channel Availability Check Time	Not required	FCC15.407 (h)	N/A	N/A
		FCC 06-96 Appendix 7.8.2.3		
		RSS-210 A9.3		
In-Service Monitoring for Channel Move Time, Channel Closing Transmission Time	Yes	FCC15.407 (h)	N/A	Complied
		FCC 06-96 Appendix 7.8.3		
		RSS-210 A9.3		
In-Service Monitoring for Non-Occupancy period	Yes *	FCC15.407 (h)	N/A	Complied
		FCC 06-96 Appendix 7.8.3		
		RSS-210 A9.3		
Statistical Performance Check	Not required	FCC15.407 (h)	N/A	N/A
		FCC 06-96 Appendix 7.8.4		

*Although this test was not required in FCC 06-96, it was performed as additional test.

Table 2: DFS Detection Thresholds for Master Devices and Client Devices With Radar

Maximum Transmit Power	Value (See Notes 1 and 2)
≥ 200 milliwatt	-64 dBm
< 200 milliwatt	-62 dBm
<p>Note 1: This is the level at the input of the receiver assuming a 0 dBi receive antenna.</p> <p>Note 2: Throughout these test procedures an additional 1 dB has been added to the amplitude of the test transmission waveforms to account for variations in measurement equipment. This will ensure that the test signal is at or above the detection threshold level to trigger a DFS response.</p>	

Table 3 DFS Response Requirement Values

Parameter	Value
Non-occupancy period	Minimum 30 minutes
Channel Availability Check Time	60 seconds
Channel Move Time	10 seconds See Note 1
Channel Closing Transmission Time	200 milliseconds + an aggregate of 60 milliseconds over remaining 10 second period. See Notes 1 and 2
U-NII Detection Bandwidth	Minimum 80% of the U-NII 99% transmission power bandwidth See Note 3
<p>Note 1: The instant that the Channel Move Time and the Channel Closing Transmission Time begins is as follows:</p> <ul style="list-style-type: none"> • For the Short Pulse Radar Test Signals this instant is the end of the <i>Burst</i>. • For the Frequency Hopping radar Test Signal, this instant is the end of the last radar <i>Burst</i> generated • For the Long Pulse Radar Test Signal this instant is the end of the 12 second period defining the <i>Radar Waveform</i>. <p>Note 2: The Channel Closing Transmission Time is comprised of 200 milliseconds starting at the beginning of the Channel Move Time plus any additional intermittent control signals required to facilitate a Channel move (an aggregate of 60 milliseconds) during the remainder of the 10 second period. The aggregate duration of control signal will not count quiet periods in between transmissions.</p> <p>Note 3: During the U-NII Detection Bandwidth detection test, radar type 1 is used and for each frequency step the minimum percentage of detection is 90 percent. Measurements are performed with no data traffic.</p>	

Table 4 Short Pulse Radar Test Waveform

Radar Type	Pulse Width (μsec)	PRI (μsec)	Number of Pulses	Minimum Percentage of Successful Detection	Minimum Number of Trials
1	1	1428	18	60%	30
2	1-5	150-230	23-29	60%	30
3	6-10	200-500	16-18	60%	30
4	11-20	200-500	12-16	60%	30
Aggregate (Rader Types 1-4)				80%	120

Table 5 Long Pulse Radar Test Waveform

Radar Type	Pulse Width (μsec)	Chip Width (MHz)	PRI (μsec)	Number of Pulses per Burst	Number of Burst	Minimum Percentage of Successful Detection	Minimum Number of Trials
5	50-100	5-20	1000-2000	1-3	8-20	80%	30

Table 6 Frequency Hopping Radar Test Waveform

Radar Type	Pulse Width (μsec)	PRI (μsec)	Pulse per Hop (kHz)	Hopping Rate (kHz)	Hopping Sequence Length (msec)	Minimum Percentage of Successful Detection	Minimum Number of Trials
6	1	333	9	0.333	300	70%	30

4.3 Test Location

UL Japan, Inc. Shonan EMC Lab.
1-22-3, Megumigaoka, Hiratsuka-shi, Kanagawa-ken 259-1220 JAPAN
Telephone number : +81 463 50 6400
Facsimile number : +81 463 50 6401

No.1/ No.2/ No.3 anechoic chamber has been fully described in a report submitted to FCC office, and accepted on April 17, 2009 (Registration No.: 697847).

IC Registration No. : 2973D-1 (No1 anechoic chamber)
2973D-2 (No2 anechoic chamber)
2973D-3 (No3 anechoic chamber)

Test room	Width x Depth x Height (m)	Test room	Width x Depth x Height (m)
No.1 Semi-anechoic chamber	20.6 x 11.3 x 7.65 Maximum measurement distance: 10m	No.1 Shielded room	6.8 x 4.1 x 2.7
No.2 Semi-anechoic chamber	20.6 x 11.3 x 7.65 Maximum measurement distance: 10m	No.2 Shielded room	6.8 x 4.1 x 2.7
No.3 Semi-anechoic chamber	12.7 x 7.7 x 5.35 Maximum measurement distance: 5m	No.3 Shielded room	6.3 x 4.7 x 2.7
No.4 Full-anechoic chamber	8.1 x 5.1 x 3.55	No.4 Shielded room	4.4 x 4.7 x 2.7
		No.5 Shielded room	7.8 x 6.4 x 2.7
		No.6 Shielded room	7.8 x 6.4 x 2.7

4.4 Test set up, Data of DFS test, and Test instruments of DFS

Refer to APPENDIX 1 to 3.

SECTION 5: Operation of E.U.T. during testing

5.1 Operating Modes

The EUT, which is a Client Device without Radar detection capability, operates over the 5260-5320MHz and 5500-5700MHz.

[W53 Band]

The highest power level is 14.85dBm EIRP in the 5250-5350MHz band.
The lowest power level is 14.62dBm EIRP in the 5250-5350MHz band.

[W56 Band]

The highest power level is 13.01dBm EIRP in the 5500-5700MHz band.
The lowest power level is 12.77dBm EIRP in the 5500-5700MHz band.

Power level of the EUT[dBm]

Antenna	Band	Antenna Gain [dBi]	Output Power (Min)	Output Power(Max)
Planar Inverted F Antenna *1)	W53	3.78	10.84	11.07
	W56	3.78	8.99	9.23

*1) Refer to 31HE0102-SH-04-A, FCC Part 15E (FCC 15.407) report for other parts than DFS.

The lowest antenna assembly gain of all available antenna assemblies is 3.78dBi.

The EUT uses one transmitter connected to two 50-ohm coaxial antenna ports via a diversity switch. Both antenna ports are connected to the test system via a power divider to perform conducted tests.

WLAN traffic is generated by streaming the MPEG Test file “6 ½ Magic Hours” from the Master to the Client in full motion video mode using the media player with the V2.61 Codec package.

The EUT utilizes the 802.11a architecture, with a nominal channel bandwidth of 18MHz.

The FCC ID for the Master Device used with EUT for DFS testing is LDK102061.

The rated output power of the Master unit is >200mW(23dBm). Therefore the required interference threshold level is –64 dBm. After correction for antenna gain and procedural adjustments, the required conducted threshold at the antenna port is $-64 + 1 + 3.5 = -59.5$ dBm (threshold level + additional 1dB + antenna gain).

5.2 Configuration and peripherals

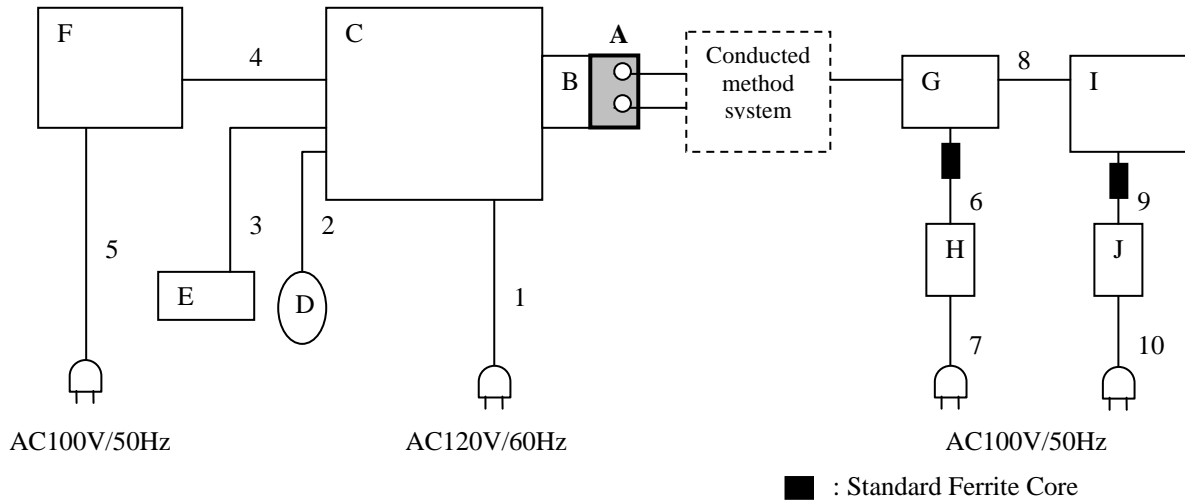

Description of EUT and Support equipment

No.	Item	Model number	Serial number	Manufacturer	Remarks
A	Wireless LAN board *1)	CMN-751A	982003000234	JRC	EUT
B	Test Jig	-	-	-	-
C	PC	DHS	175881X	DELL	-
D	Monitor	540N	HA15H9NP601034Z	SAMSUNG	-
E	Keyboard	KB-0316	BC3480FVBW2AR 0	hp	-
F	Mouse	M-UAE96	F9390H5BVZ2970	hp	-
G	Wireless LAN access point (Master Device)	AIR-AP1252AG-A-K9	FTX130390F4	Cisco Systems	FCC ID: LDK102061
H	AC Adapter	EADP-45BB	DTH1241908P	Cisco Systems	-
I	Note PC	DELL Vostro V1510	29090510205	Dell	-
J	ACAdapter	LA65NS1-00	71615-93B-385D	Dell	-

*1) This board is installed AeroDR P-21.

List of cables used

No.	Name	Length (m)	Shield	
			Cable	Connector
1	PC AC Power Cable	2.0	Unshielded	Unshielded
2	Mouse Cable	1.8	Shielded	Shielded
3	Keyboard Cable	1.7	Shielded	Shielded
4	PC Monitor RGB Cable	1.7	Shielded	Shielded
5	PC Monitor AC Power Cable	1.5	Unshielded	Unshielded
6	Access Point DC Power Cable	1.8	Unshielded	Unshielded
7	Access Point AC Power Cable	2.0	Unshielded	Unshielded
8	NIC Cable	3.0	Unshielded	Unshielded
9	Note PC DC Power Cable	1.8	Unshielded	Unshielded
10	Note PC AC Power Cable	0.7	Unshielded	Unshielded

UL Japan, Inc. Shonan EMC Lab.

1-22-3 Megumigaoka, Hiratsuka-shi, Kanagawa-ken, 259-1220 JAPAN
Telephone: +81 463 50 6400
Facsimile: +81 463 50 6401

5.3 Test and Measurement System

SYSTEM OVERVIEW

The measurement system is based on a conducted test method.

The software selects waveform parameters from within the bounds of the signal type on a random basis using uniform distribution. The short pulse types 2, 3, and 4, the long pulse type 5, and the frequency hopping type 6 parameters are randomized at run-time.

The signal monitoring equipment consists of a spectrum analyzer with the capacity to display 8001 bins on the horizontal axis. A time-domain resolution of 2 msec/bin is achievable with a 16 second sweep time, meeting the 10 seconds short pulse reporting criteria. The aggregate ON time is calculated by multiplying the number of bins above a threshold during a particular observation period by the dwell time per bin, with the analyzer set to peak detection. A time-domain resolution of 3 msec/bin is achievable with a 24 second sweep time, meeting the 22 second long pulse reporting criteria and allowing a minimum of 10 seconds after the end of the long pulse waveform.

FREQUENCY HOPPING RADAR WAVEFORM GENERATING SUBSYSTEM

The first 100 frequencies are selected out of the hopping sequence of the randomized 475 hop frequencies.

Only a *Burst* that has the frequency falling within the receiver bandwidth of the tested U-NII device is selected among those frequencies. (Frequency-domain simulation). The radar waveform generated at the start time of the selected *Burst* (Time-domain simulation) is download to the Signal Generator.

If all of the randomly selected 100 frequencies do not fall within the receiver bandwidth of the U-NII device, the radar waveform is not used for the test.

UL Japan, Inc.

Shonan EMC Lab.

1-22-3 Megumigaoka, Hiratsuka-shi, Kanagawa-ken, 259-1220 JAPAN

Telephone: +81 463 50 6400

Facsimile: +81 463 50 6401

CONDUCTED METHODS SYSTEM BLOCK DIAGRAM

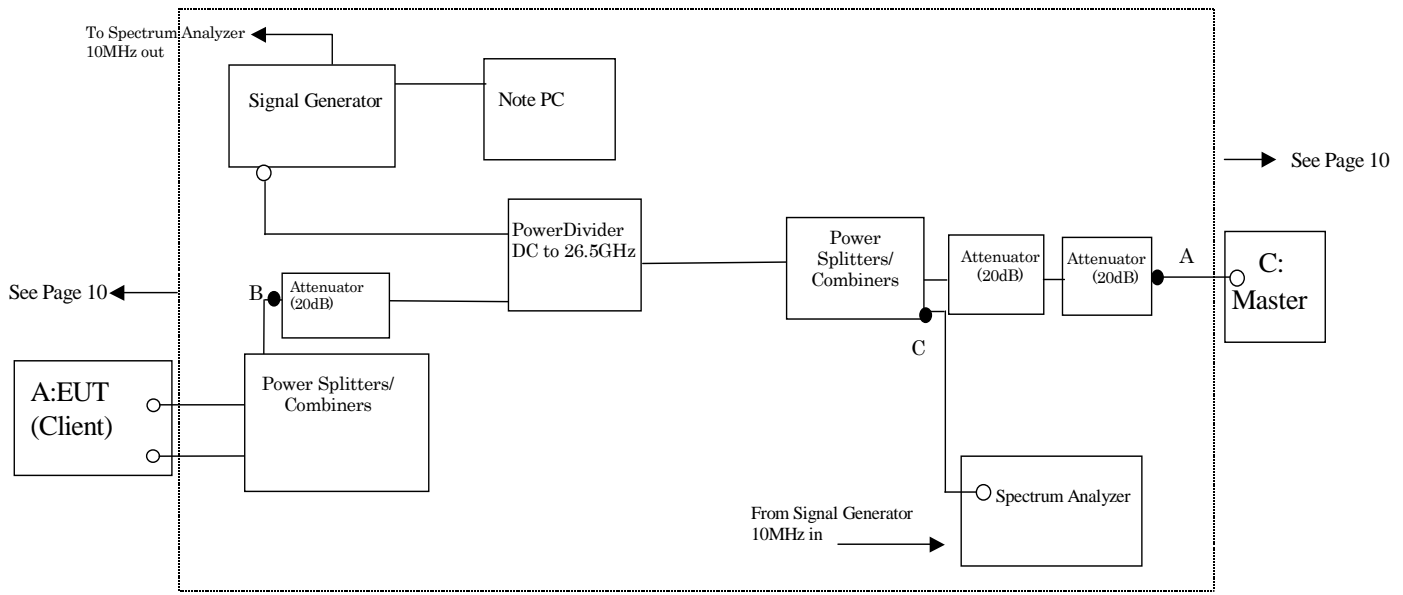

MEASUREMENT SYSTEM FREQUENCY REFERENCE

Lock the signal generator and the spectrum analyzer to the same reference sources as follows: Connect the 10MHz OUT on the signal generator to the 10MHz IN on the spectrum analyzer and set the spectrum analyzer 10MHz In to On.

SYSTEM CALIBRATION

Step 1: Set the system as shown in Figure 3 of FCC 06-96 7.2.1.

Step 2: Adjust each attenuator to fulfill the following three conditions:

- WLAN can be communicated, and
- Rader detection threshold level is bigger than Client Device traffic level on the spectrum analyzer, and
- Master Device traffic level is not displayed on the spectrum analyzer.

Step 3: Terminate 50 ohm at B and C points, and connect the spectrum analyzer to the point A. (See the figure on page 12)

At the point A, adjust the signal generator and spectrum analyzer to the center frequency of the channel to be measured. Download the applicable radar waveforms to the signal generator. Select the radar waveform, trigger a burst manually and measure the amplitude on the spectrum analyzer. Readjust the amplitude of the signal generator as required so that the peak level of the waveform is at a displayed level equal to the required or desired interference detection threshold. Separate signal generator amplitude settings are determined as required for each radar type.

Step 4: Without changing any of the instrument settings, restore the system setting to Step 2 and adjust the Reference Level Offset of the spectrum analyzer to the level at Step 3.

By taking the above steps 1 to 4, the spectrum analyzer displays the level of the signal generator as received at the antenna ports of the Master Device.

See Clause 5.4 for Plots of Noise, Rader Waveforms, and WLAN signals.

5.4 Plots of Noise, Rader Waveforms, and WLAN signals

Plots of System Noise Floor

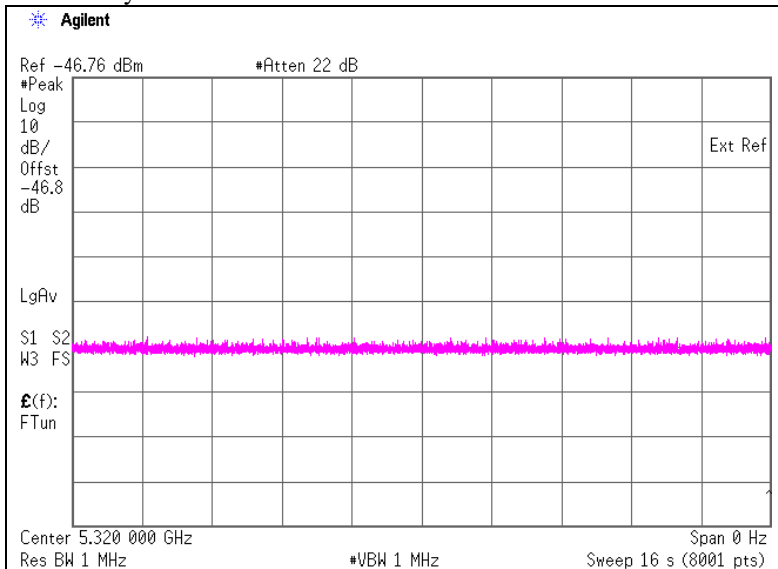

It was confirmed that the EUT did not transmit before having received appropriate control signals from a Master Device.

Plots of Radar Waveforms

Rader Type 1

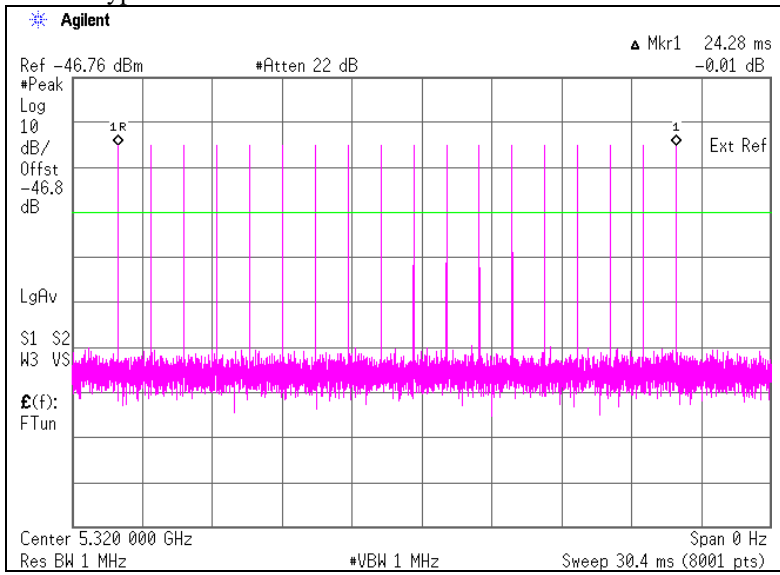

Rader Type 5

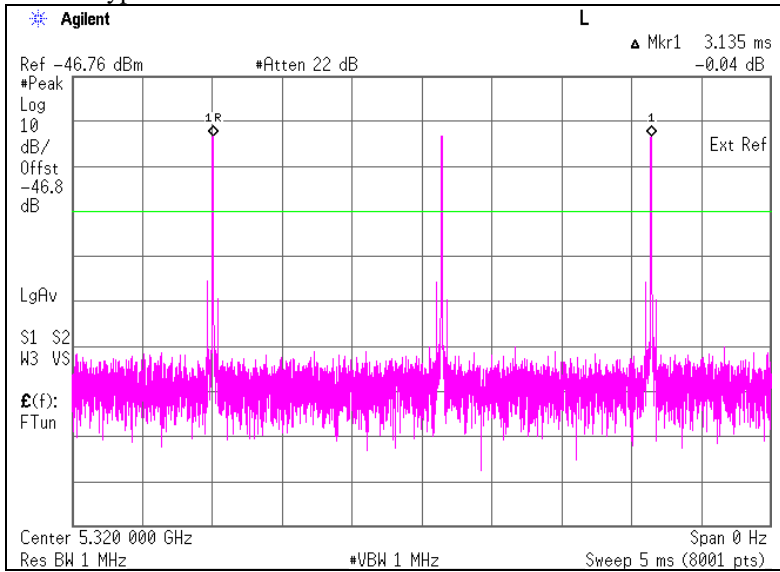

UL Japan, Inc.
Shonan EMC Lab.

1-22-3 Megumigaoka, Hiratsuka-shi, Kanagawa-ken, 259-1220 JAPAN

Telephone: +81 463 50 6400

Facsimile: +81 463 50 6401

Plots of WLAN Traffic

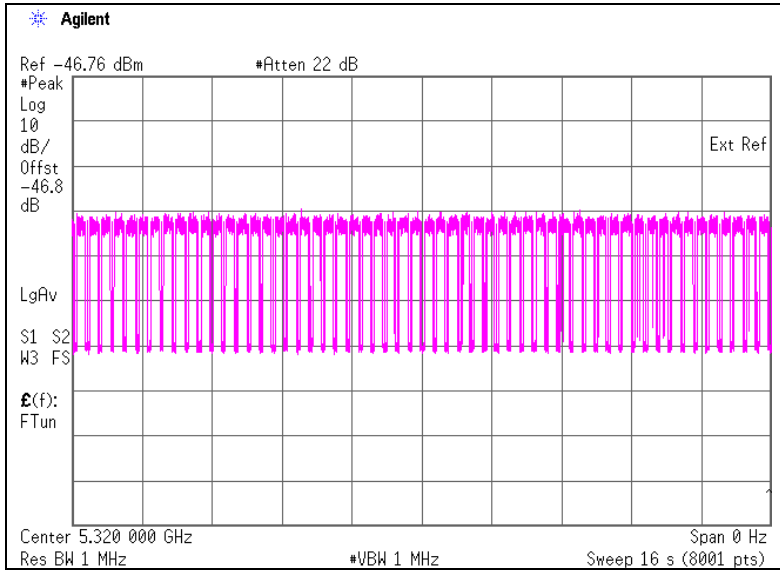

UL Japan, Inc.
Shonan EMC Lab.

1-22-3 Megumigaoka, Hiratsuka-shi, Kanagawa-ken, 259-1220 JAPAN

Telephone: +81 463 50 6400

Facsimile: +81 463 50 6401

SECTION 6: In-Service Monitoring for Channel Move Time, Channel Closing Transmission Time

6.1 Operating environment

Test place : No.5 Shielded room
Temperature : 24 deg.C.
Humidity : 51 %

6.2 Test Procedure

Stream the MPEG test file from the Master Device to the Client Device on the test Channel for the entire period of the test.

The Radar Waveform generator sends a Burst of pulses for one of the Short Pulse Radar Types 1-4 at levels defined , on the Operating Channel. An additional 1 dB is added to the radar test signal to ensure it is at or above the DFS Detection Threshold, accounting for equipment variations/errors.

Observe the transmissions of the EUT at the end of the radar Burst on the Operating Channel for duration greater than 10 seconds.

6.3 Test data

Test Item	Unit	Measurement Time	Limit	Results
Channel Move Time *1)	[sec]	5.132	10.000	Pass
Channel Closing Transmission Time *2)	[msec]	54	60	Pass

*1) Channel Move Time is calculated as follows:

$$(\text{Channel Move Time}) = (\text{End of Transmission}) - (\text{End of Burst}) = 6.558 - 1.426$$

*2) Channel Closing Transmission Time is calculated from (End of Burst + 200msec) to (End of Burst + 10sec)

$$(\text{Channel Closing Transmission Time}) = (\text{Number of analyzer bins showing transmission}) * (\text{dwell time per bin}) \\ = 27 * 2(\text{msec})$$

Radar Type 1

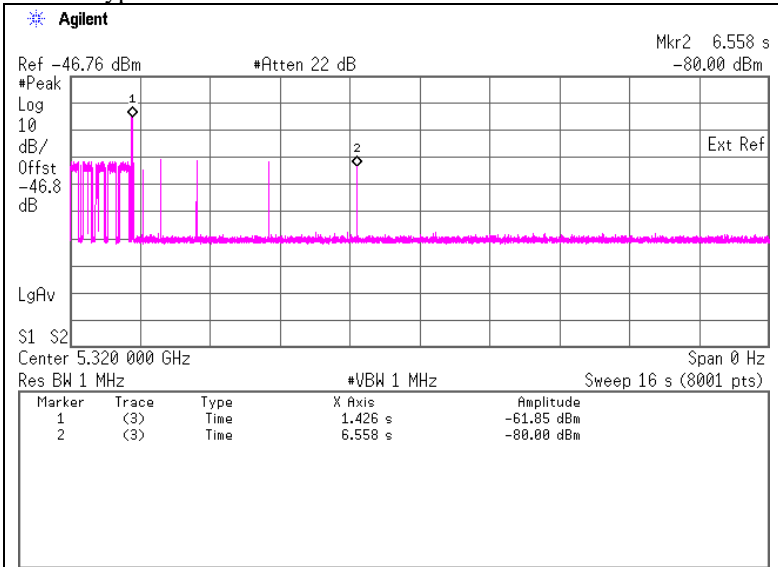

Marker 1: - End of Burst : 1426 ms
Marker 2: - End of Transmission : 6558 ms

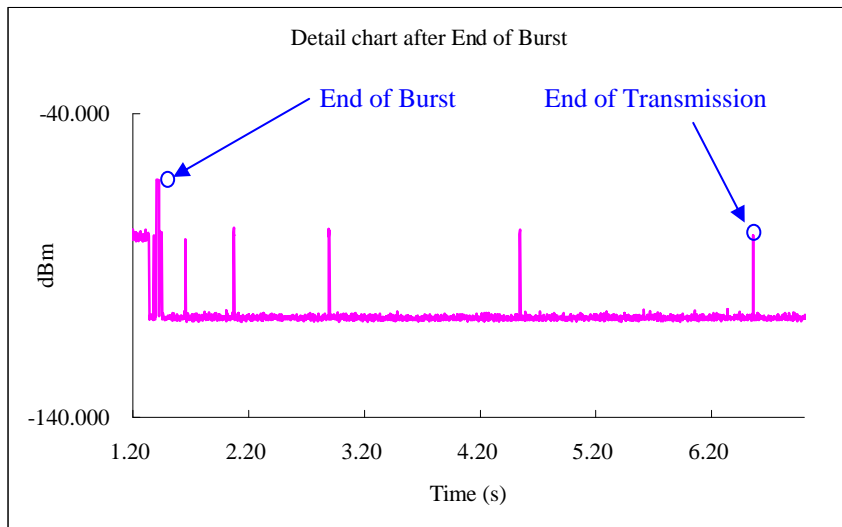

*) Number of analyzer bins which are occupied in 5-burst from End of Burst to End of Transmission: 27

Radar Type 5

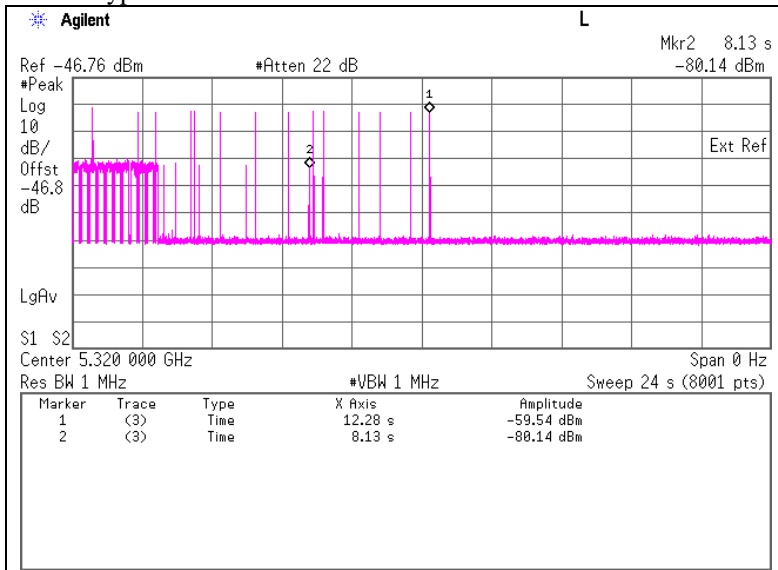

Marker 1 : End of Burst : 12280 ms
Marker 2 : End of Transmission : 8130 ms

6.4 Test result

Test result: Pass

Date : June 9, 2010

Test engineer : Tatsuya Arai

SECTION 7: In-Service Monitoring for Non-Occupancy Period

7.1 Operating environment

Test place : No.5 Shielded room
Temperature : 24 deg.C.
Humidity : 51 %

7.2 Test Procedure

The following two tests are performed:

1).Stream the MPEG test file from the Master Device to the Client Device on the test Channel for the entire period of the test.

The Radar Waveform generator sends a Burst of pulses for one of the Radar Types 1-6 at levels defined on the Operating Channel. An additional 1 dB is added to the radar test signal to ensure it is at or above the DFS Detection Threshold, accounting for equipment variations/errors.

Observe the transmissions of the EUT after the Channel Move Time on the Operating Channel for duration greater than 30 minutes.

2). Stream the MPEG test file from the Master Device to the Client Device on the test Channel for the entire period of the test.

Observe the transmissions of the EUT on the Operating Channel for duration greater than 30 minutes after the Master Device is shut off.

7.3 Test data

1).Radar Type 1

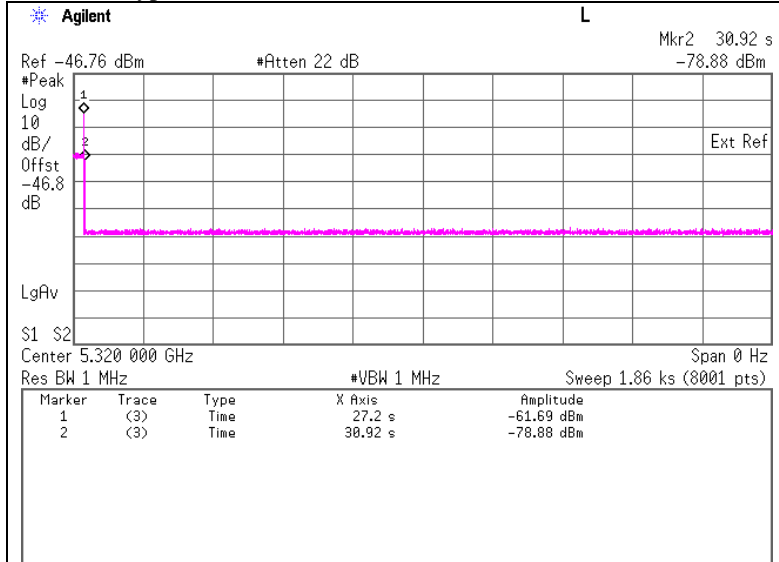

Marker 1 : End of Burst : 27.2 sec

Marker 2 : End of Burst +10sec : 37.2 sec

UL Japan, Inc.
Shonan EMC Lab.

1-22-3 Megumigaoka, Hiratsuka-shi, Kanagawa-ken, 259-1220 JAPAN

Telephone: +81 463 50 6400

Facsimile: +81 463 50 6401

2).Master is shut off

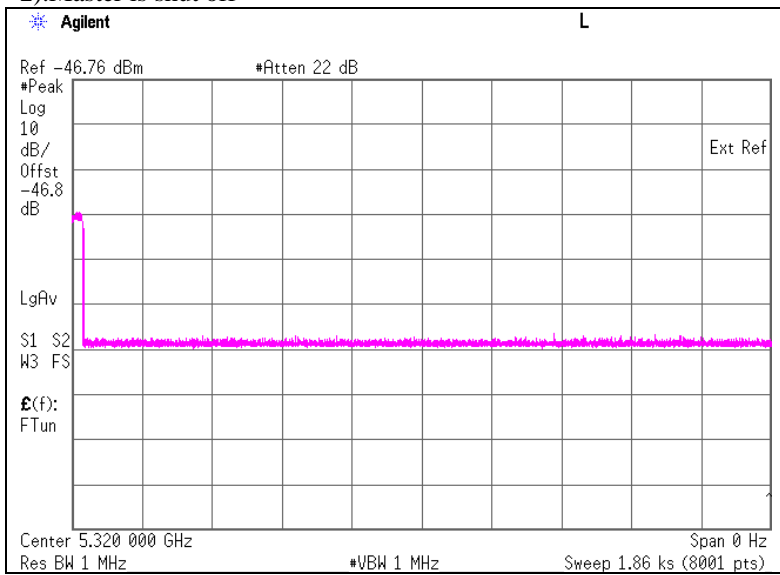

7.4 Test result

Test result: Pass

Date : June 9, 2010

Test engineer : Tatsuya Arai