

# FCC Test Report

**FCC ID** : YQMLLS090  
**Equipment** : Focus Premium  
**Model No.** : Focus Premium  
**Brand Name** : FARO  
**Applicant** : FARO Technologies, Inc.  
**Address** : 250 Technology Park, Lake Mary, Florida,  
United States, 32746  
**Standard** : 47 CFR FCC Part 15.209  
**Received Date** : Dec. 16, 2021  
**Tested Date** : Feb. 24 ~ Mar. 02, 2022

We, International Certification Corporation, would like to declare that the tested sample has been evaluated and in compliance with the requirement of the above standards. The test results contained in this report refer exclusively to the product. It shall not be reproduced except in full without the written approval of our laboratory.

Reviewed by:

Approved by:

  
\_\_\_\_\_  
Along Chen / Assistant Manager

  
\_\_\_\_\_  
Gary Chang / Manager

---

## Table of Contents

<b>1</b>	<b>GENERAL DESCRIPTION .....</b>	<b>5</b>
1.1	Information.....	5
1.2	Local Support Equipment List .....	6
1.3	Test Setup Chart .....	6
1.4	The Equipment List .....	7
1.5	Test Standards .....	8
1.6	Deviation from Test Standard and Measurement Procedure.....	8
1.7	Measurement Uncertainty .....	8
<b>2</b>	<b>TEST CONFIGURATION .....</b>	<b>9</b>
2.1	Testing Facility.....	9
2.2	The Worst Test Modes and Channel Details .....	9
<b>3</b>	<b>TRANSMITTER TEST RESULTS.....</b>	<b>10</b>
3.1	20dB and Occupied Bandwidth .....	10
3.2	Radiated Emissions.....	12
<b>4</b>	<b>TEST LABORATORY INFORMATION .....</b>	<b>17</b>

---

## Release Record

Report No.	Version	Description	Issued Date
FR1D1602NF	Rev. 01	Initial issue	May 04, 2022
FR1D1602NF	Rev. 02	Corrected received date of test sample	Jun. 01, 2022

## Summary of Test Results

FCC Rules	Test Items	Measured	Result
15.207	Conducted Emissions	Meet the requirement of limit	Pass
15.209	Radiated Emissions	Meet the requirement of limit	Pass
15.215 (c)	20dB bandwidth	Meet the requirement of limit	Pass
15.203	Antenna Requirement	Meet the requirement of limit	Pass

**Declaration of Conformity:**

The test results with all measurement uncertainty excluded are presented in accordance with the regulation limits or requirements declared by manufacturers.

**Comments and Explanations:**

The declared of product specification for EUT presented in the report are provided by the manufacturer, and the manufacturer takes all the responsibilities for the accuracy of product specification.

# 1 General Description

## 1.1 Information

### 1.1.1 Specification of the Equipment under Test (EUT)

RF General Information			
Frequency Range (MHz)	Modulation	Ch. Frequency (MHz)	Channel Number
13.553 – 13.567	NFC-ASK	13.56	1

### 1.1.2 Antenna Details

Ant. No.	Type	Gain (dBi)	Connector	Remark
1	PCB integrated Antenna	---	---	---

### 1.1.3 EUT Operational Condition

<b>Supply Voltage</b>	14.4Vdc from battery		
<b>Operational Voltage</b>	<input checked="" type="checkbox"/> Vnom (14.4 V)	<input checked="" type="checkbox"/> Vmax (16.8 V)	<input checked="" type="checkbox"/> Vmin (12.7 V)
<b>Operational Climatic</b>	<input checked="" type="checkbox"/> Tnom (20°C)	<input checked="" type="checkbox"/> Tmax (55°C)	<input checked="" type="checkbox"/> Tmin (-20°C)

### 1.1.4 Accessories

Accessories		
No.	Equipment	Description
1	Battery	Brand: Akku Power GmbH Model: ACCS-PWR-0014 Power Rating: Nom. Voltage: 14.4V Capacity: 6.8Ah Watt Hour: 97.92Wh Serial Number: 01562
2	3D_AC_LS_SD Card Reader	Brand: Transcend Model: G23758
3	SD Card	Brand: SanDisk Extreme PRO (170MB/s) Capacity: 64GB
4	Status Indicator	Model: 900-000038-001

### 1.1.5 Test Sample Information

<b>Serial Number of Test Sample</b>	Radiated Emission: LLS092125013
-------------------------------------	---------------------------------

### 1.1.6 Test Tool and Power Setting

<b>Test tool</b>	NfcFactoryTestApp
<b>Modulation Mode</b>	NFC
<b>Setting</b>	Default

## 1.2 Local Support Equipment List

Support Equipment List					
No.	Equipment	Brand	Model	FCC ID	Remarks
1	USB 3.1 Flash	pqi	Connect 313/16GB	---	---
2	SD Card	SanDisk	16GB	---	Provided by applicant.

## 1.3 Test Setup Chart

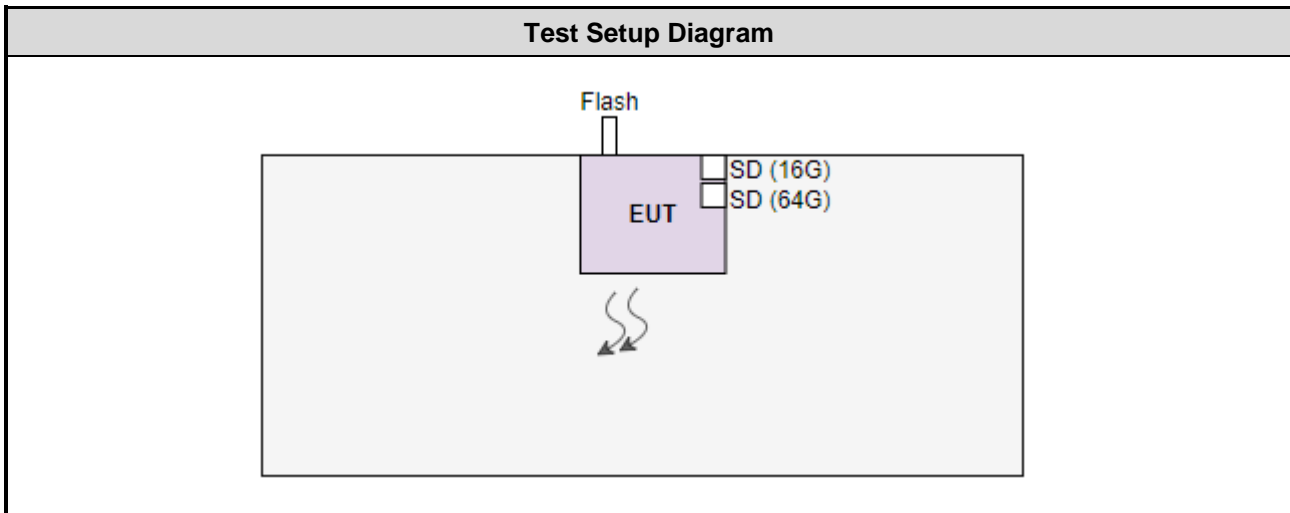

## 1.4 The Equipment List

<b>Test Item</b>	Radiated Emission				
<b>Test Site</b>	966 chamber3 / (03CH03-WS)				
<b>Tested Date</b>	Feb. 24, 2022				
<b>Instrument</b>	<b>Brand</b>	<b>Model No.</b>	<b>Serial No.</b>	<b>Calibration Date</b>	<b>Calibration Until</b>
Receiver	R&S	ESR3	101657	Mar. 12, 2021	Mar. 11, 2022
Loop Antenna	R&S	HFH2-Z2	100330	Nov. 08, 2021	Nov. 07, 2022
Bilog Antenna	SCHWARZBECK	VULB9168	VULB9168-685	May 06, 2021	May 05, 2022
Preamplifier	EMC	EMC02325	980187	Jul. 26, 2021	Jul. 25, 2022
Loop Antenna Cable	KOAX KABEL	101354-BW	101354-BW	Oct. 05, 2021	Oct. 04, 2022
LF cable-0.8M	EMC	EMC8D-NM-NM-800	EMC8D-NM-NM-800-001	Sep. 24, 2021	Sep. 23, 2022
LF cable-3M	EMC	EMC8D-NM-NM-3000	131103	Sep. 24, 2021	Sep. 23, 2022
LF cable-13M	EMC	EMC8D-NM-NM-13000	131104	Sep. 24, 2021	Sep. 23, 2022
Measurement Software	AUDIX	e3	6.120210g	NA	NA
Note: Calibration Interval of instruments listed above is one year.					

<b>Test Item</b>	RF Conducted				
<b>Test Site</b>	(TH01-WS)				
<b>Tested Date</b>	Mar. 02, 2022				
<b>Instrument</b>	<b>Brand</b>	<b>Model No.</b>	<b>Serial No.</b>	<b>Calibration Date</b>	<b>Calibration Until</b>
Power Meter	Anritsu	ML2495A	1241002	Nov. 07, 2021	Nov. 06, 2022
Power Sensor	Anritsu	MA2411B	1207366	Nov. 07, 2021	Nov. 06, 2022
DC POWER SOURCE	GW INSTRON	GPC-6030D	GES855395	Nov. 08, 2021	Nov. 07, 2022
TEMP&HUMIDITY CHAMBER	GIANT FORCE	GCT-225-40-SP-SD	MAF1212-002	May 25, 2021	May 24, 2022
Note: Calibration Interval of instruments listed above is one year.					

## 1.5 Test Standards

47 CFR FCC Part 15.209

ANSI C63.10-2013

## 1.6 Deviation from Test Standard and Measurement Procedure

None

## 1.7 Measurement Uncertainty

The measurement uncertainties given below are based on a 95% confidence level (based on a coverage factor ( $k=2$ )).

Measurement Uncertainty	
Parameters	Uncertainty
Bandwidth	$\pm 34.130$ Hz
Conducted power	$\pm 0.808$ dB
AC conducted emission	$\pm 2.92$ dB
Radiated emission $\leq 1$ GHz	$\pm 3.96$ dB
Radiated emission $> 1$ GHz	$\pm 4.51$ dB



## 2 Test Configuration

### 2.1 Testing Facility

<b>Test Laboratory</b>	International Certification Corporation
<b>Test Site</b>	TH01-WS
<b>Address of Test Site</b>	No.3-1, Lane 6, Wen San 3rd St., Kwei Shan Dist., Tao Yuan City 33381, Taiwan (R.O.C.)
<b>Test Site</b>	03CH03-WS
<b>Address of Test Site</b>	No.14-1, Lane 19, Wen San 3rd St., Kwei Shan Dist., Tao Yuan City 333, Taiwan (R.O.C.)

- FCC Designation No.: TW0009
- FCC site registration No.: 207696
- ISED#: 10807A
- CAB identifier: TW2732

### 2.2 The Worst Test Modes and Channel Details

Test item	Mode	Test Frequency (MHz)
Radiated Emissions	NFC	13.56
20dB bandwidth	NFC	13.56

## 3 Transmitter Test Results

### 3.1 20dB and Occupied Bandwidth

#### 3.1.1 Limit of 20dB Bandwidth

The upper and lower frequency of the 20dB bandwidth shall within 13.553~13.567 MHz

#### 3.1.2 Test Procedures

1. Set resolution bandwidth (RBW) = 1 kHz, Video bandwidth = 3 kHz.
2. Detector = Peak, Trace mode = max hold.
3. Sweep = auto couple, Allow the trace to stabilize.
4. Measure the maximum width of the emission that is constrained by the frequencies associated with the two outermost amplitude points (upper and lower) that are attenuated by 20dB relative to the maximum level measured in the fundamental emission.

#### 3.1.3 Test Setup

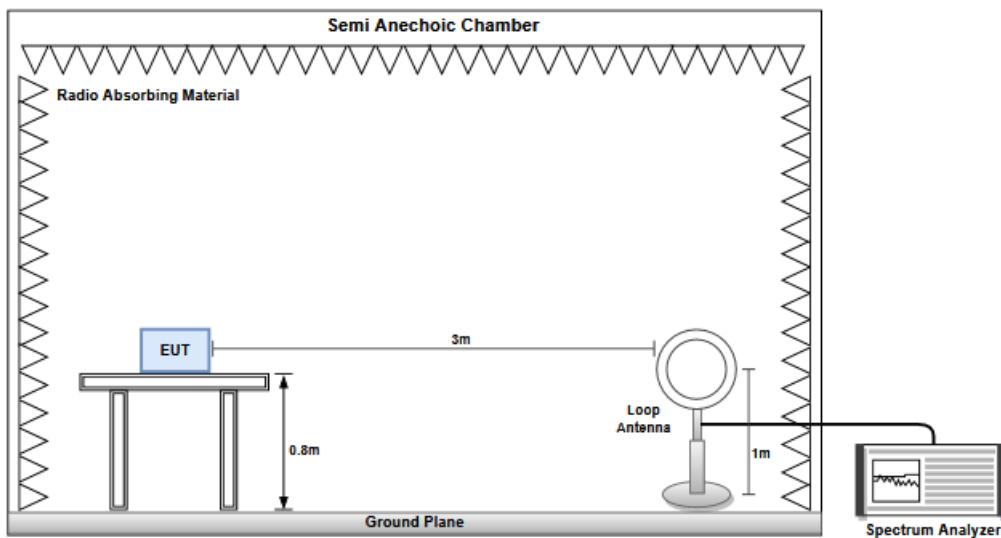

### 3.1.4 Test Result of 20dB and Occupied Bandwidth

<b>Ambient Condition</b>	24°C / 64%	<b>Tested By</b>	Aska Huang
--------------------------	------------	------------------	------------

Modulation Mode	Freq. (MHz)	20dB Bandwidth (kHz)	F <sub>L</sub> at 20dB BW (MHz)	F <sub>H</sub> at 20dB BW (MHz)	99% Bandwidth (kHz)
NFC	13.56	2.627	13.559153	13.56178	2.21482344
<b>Limit</b>		N/A	13.553	13.567	N/A

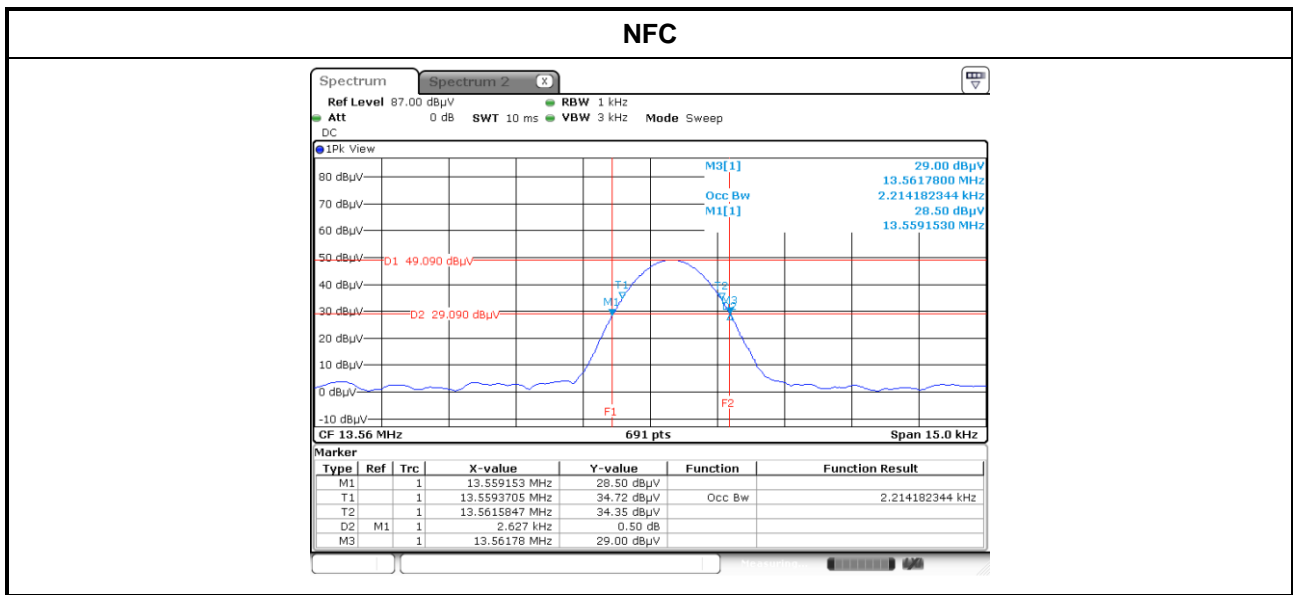

## 3.2 Radiated Emissions

### 3.2.1 Limit of Radiated Emissions

Restricted Band Emissions Limit			
Frequency Range (MHz)	Field Strength (uV/m)	Field Strength (dBuV/m)	Measure Distance (m)
0.009~0.490	2400/F(kHz)	48.5 - 13.8	300
0.490~1.705	24000/F(kHz)	33.8 - 23	30
1.705~30.0	30	29.54	30
30~88	100	40	3
88~216	150	43.5	3
216~960	200	46	3
Above 960	500	54	3

**Note 1:**  
Quasi-Peak value is measured for frequency below 1GHz except for 9–90 kHz, 110–490 kHz frequency band. Peak and average value are measured for frequency above 1GHz. The limit on average radio frequency emission is as above table. The limit on peak radio frequency emissions is 20 dB above the maximum permitted average emission limit

**Note 2:**  
Measurements may be performed at a distance other than what is specified provided. When performing measurements at a distance other than that specified, the results shall be extrapolated to the specified distance using an extrapolation factor as below, Frequency at or above 30 MHz: 20 dB/decade Frequency below 30 MHz: 40 dB/decade.

### 3.2.2 Test Procedures

1. Measurement is made at a semi-anechoic chamber that incorporates a turntable allowing a EUT rotation of 360°. A continuously-rotating, remotely-controlled turntable is installed at the test site to support the EUT and facilitate determination of the direction of maximum radiation for each EUT emission frequency. The EUT is placed at a height of 0.8 m test table above the ground plane.
2. Measurement is made with the antenna positioned in both the horizontal and vertical planes of polarization. The measurement antenna is varied in height (1m ~ 4m) above the reference ground plane to obtain the maximum signal strength. Distance between EUT and antenna is 3 m.
3. This investigation is performed with the EUT rotated 360°, the antenna height scanned between 1 m and 4 m, and the antenna rotated to repeat the measurements for both the horizontal and vertical antenna polarizations.

Note:

1. 120kHz measurement bandwidth of test receiver and Quasi-peak detector is for radiated emission below 1GHz.

### 3.2.3 Test Setup

#### Radiated Emissions below 30MHz

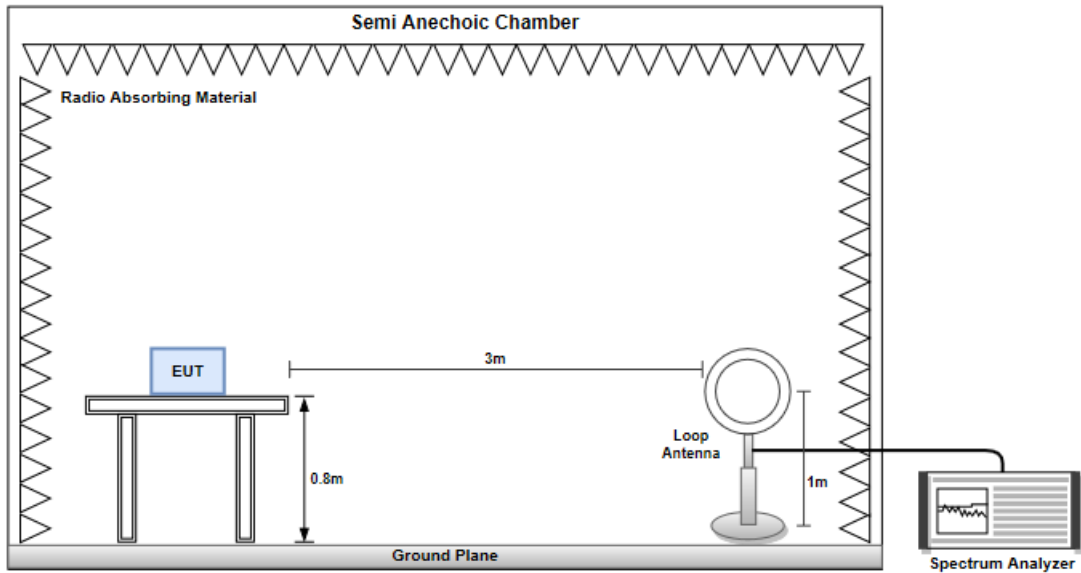

#### Radiated Emissions below 1 GHz

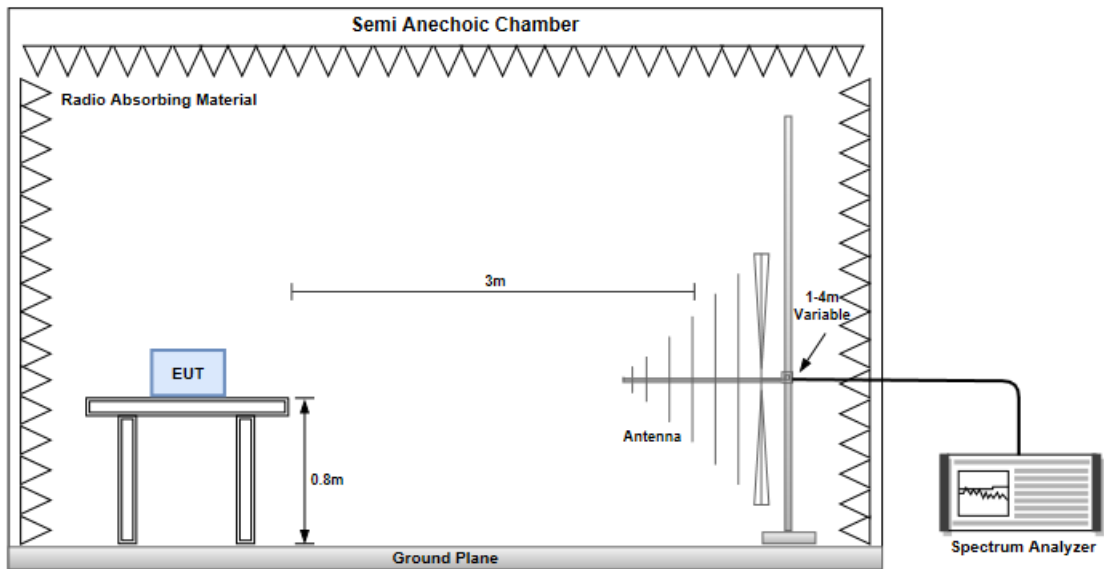

### 3.2.4 Transmitter Radiated Unwanted Emissions (9k ~ 30MHz)

<b>Ambient Condition</b>	21°C / 69%	<b>Tested By</b>	Roger Lu
--------------------------	------------	------------------	----------

Loop Pol. open

Emission Freq. (MHz)	Emission Level (dBuV/m)	FS max Limit (dBuV/m)	Margin (dB)	SA Reading (dBuV)	Factor (dB)	Remark
*13.56	73.38	105.39	-32.01	49	24.38	QP
13.41	28.54	62	-33.46	4.2	24.34	QP
13.553	33.18	71.87	-38.69	8.8	24.38	QP
13.567	38.28	71.86	-33.58	13.9	24.38	QP
13.71	28.72	61.81	-33.09	4.3	24.42	QP
27.12	23.33	49.54	-26.21	3.5	19.83	QP

Note: "\*" is fundamental frequency.

Loop Pol. close

Emission Freq. (MHz)	Emission Level (dBuV/m)	FS max Limit (dBuV/m)	Margin (dB)	SA Reading (dBuV)	Factor (dB)	Remark
*13.56	63.88	105.39	-41.51	39.5	24.38	QP
13.41	28.49	62	-33.51	4.15	24.34	QP
13.553	29.58	71.87	-42.29	5.2	24.38	QP
13.567	31.88	71.86	-39.98	7.5	24.38	QP
13.71	28.64	61.81	-33.17	4.22	24.42	QP
27.12	23.22	49.54	-26.32	3.39	19.83	QP

Note: "\*" is fundamental frequency.

### 3.2.5 Transmitter Radiated Unwanted Emissions (30M ~ 1GHz)

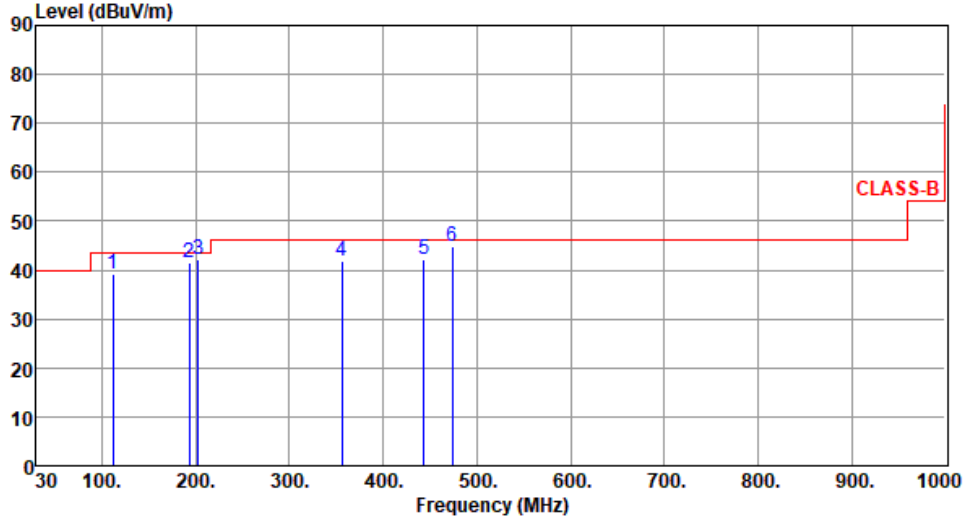
<b>Polarization</b>	Horizontal	<b>Test Freq. (MHz)</b>	13.56						
<b>Test Mode</b>	NFC								
Test By : Akun Chung      Temperature(°C): 21      Humidity(%): 69									
									
	Freq.	Emission level	Limit	Margin	SA reading	Factor	Remark	ANT High	Turn Table
	MHz	dBuV/m	dBuV/m	dB	dBuV	dB/m		cm	deg
1	111.48	39.14	43.50	-4.36	50.83	-11.69	Peak	---	---
2	192.96	41.56	43.50	-1.94	53.11	-11.55	QP	120	222
3	202.66	42.10	43.50	-1.40	53.85	-11.75	QP	115	223
4	355.92	41.89	46.00	-4.11	48.65	-6.76	Peak	---	---
5	443.22	42.30	46.00	-3.70	46.23	-3.93	QP	182	225
6	474.26	44.95	46.00	-1.05	48.11	-3.16	QP	174	66

Note 1: Emission Level (dBuV/m) = SA Reading (dBuV) + Factor\* (dB)

\*Factor includes antenna factor , cable loss and amplifier gain

Note 2: Margin (dB) = Emission level (dBuV/m) – Limit (dBuV/m)

<b>Polarization</b>	Vertical	<b>Test Freq. (MHz)</b>	13.56
<b>Test Mode</b>	NFC		
Test By	:Akun Chung	Temperature(°C):21	Humidity(%):69

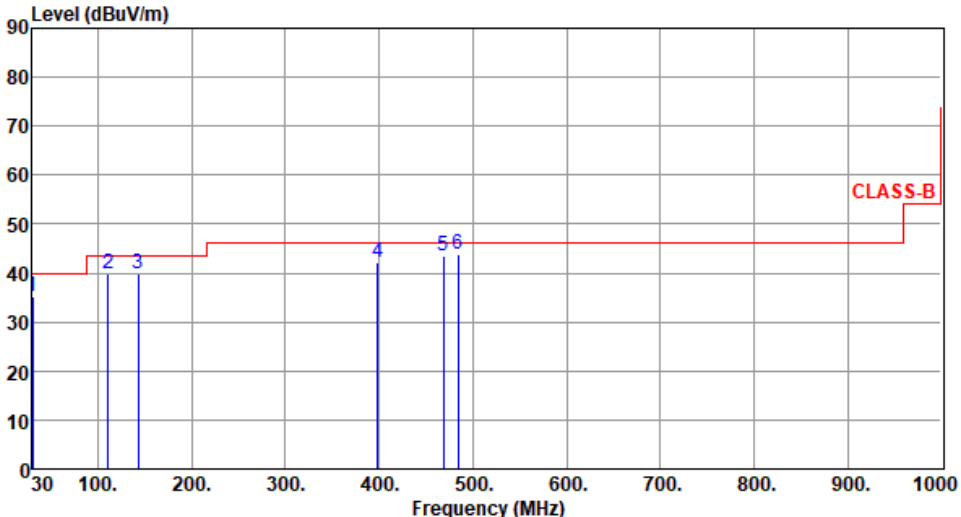
	Freq. MHz	Emission level dBuV/m	Limit dBuV/m	Margin dB	SA reading dBuV	Factor dB/m	Remark	ANT High cm	Turn Table deg
1	30.00	35.34	40.00	-4.66	45.82	-10.48	Peak	---	---
2	110.51	39.88	43.50	-3.62	51.73	-11.85	Peak	---	---
3	142.52	39.98	43.50	-3.52	48.89	-8.91	Peak	---	---
4	398.60	42.18	46.00	-3.82	47.71	-5.53	Peak	---	---
5	468.44	43.58	46.00	-2.42	46.88	-3.30	QP	100	2
6	483.96	43.78	46.00	-2.22	46.86	-3.08	QP	100	7

Note 1: Emission Level (dBuV/m) = SA Reading (dBuV) + Factor\* (dB)  
 \*Factor includes antenna factor , cable loss and amplifier gain  
 Note 2: Margin (dB) = Emission level (dBuV/m) – Limit (dBuV/m)



## 4 Test laboratory information

Established in 2012, ICC provides foremost EMC & RF Testing and advisory consultation services by our skilled engineers and technicians. Our services employ a wide variety of advanced edge test equipment and one of the widest certification extents in the business.

International Certification Corporation (EMC and Wireless Communication Laboratory), it is our definitive objective is to institute long term, trust-based associations with our clients. The expectation we set up with our clients is based on outstanding service, practical expertise and devotion to a certified value structure. Our passion is to grant our clients with best EMC / RF services by oriented knowledgeable and accommodating staff.

Our Test sites are located at Linkou District and Kwei Shan District. Location map can be found on our website <http://www.icertifi.com.tw>.

### **Linkou**

Tel: 886-2-2601-1640

No.30-2, Ding Fwu Tsuen, Lin Kou District, New Taipei City, Taiwan (R.O.C.)

### **Kwei Shan**

Tel: 886-3-271-8666

No.3-1, Lane 6, Wen San 3rd St., Kwei Shan Dist., Tao Yuan City 33381, Taiwan (R.O.C.)

No.2-1, Lane 6, Wen San 3rd St., Kwei Shan Dist., Tao Yuan City 33381, Taiwan (R.O.C.)

### **Kwei Shan Site II**

Tel: 886-3-271-8640

No.14-1, Lane 19, Wen San 3rd St., Kwei Shan Dist., Tao Yuan City 333, Taiwan (R.O.C.)

If you have any suggestion, please feel free to contact us as below information.

Tel: 886-3-271-8666

Fax: 886-3-318-0345

Email: ICC\_Service@icertifi.com.tw

==END==