

TEST REPORT

上海市计量测试技术研究院  
华东国家计量测试中心  
中国上海测试中心

# 检测报告

委托者 Customer: Queclink Wireless Solutions Co., Ltd  
委托者地址 Address of customer: Room 501, Building 9, No. 99 TianZhou Road, Shanghai, China  
样品名称 Name of sample: GPS Locator  
制造厂 Manufacturer: Queclink Wireless Solutions Co., Ltd  
型号/规格 Model/Specification: GL100S  
样品编号 No. of sample: 08#

批准人/职务 Approved by / Functions: 王明 副主任  
(机构检测专用章) 核验员 Checked by: 刘德  
检测员 Tested by: 马士平

检测日期 Date for test: 2011 年 06 月 21 日  
Year Month Day

地址: 上海市张衡路 1500 号(总部) Address No.1500 Zhangheng Road, Shanghai(headquarters)  
电话: 021-38839800 Tel.  
传真: 021-50798390 Fax  
邮编: 201203 Post Code  
客户咨询电话: 800-820-5172 Inquire line  
投诉电话: 021-50798262 Tel. for complaint

国家法定计量检定机构计量授权证书号(中心/院): (国)法计(2007)01039号/(2007)01019号  
The number of the Certificate of Metrological Authorization to The Legal Metrological Verification Institution is No. (2007) 01039 / No. (2007) 01019

中国合格评定国家认可委员会实验室认可证书号: No. CNAS L0134  
The number of the certificate accredited by CNAS is No.L0134

中国国家认证认可监督管理委员会资质认定计量认证证书(CMA)号: 2009000597E  
The number of the metrology accreditation certificate by CNCA is No. 2009000597E

本次检测所依据的技术规范(代号、名称):  
Reference documents for the test (code , name)

FCC part 22: 2009 Part 22: Public Mobile Services

FCC part 24: 2009 Part 24: Personal Communications Services

本次检测所使用的主要测量仪器:  
Main measuring instruments used in this test

Refer to Attachment 1

检测地点及环境条件:  
Location and environmental condition for the test

地点: SIMT EMC, No.716, Yishan Road Shanghai  
Location

温度: (20-24) °C; 湿度: (40-56) %RH; 其它: /  
Ambient temperature Relative humidity Others

检测结果/说明:  
Results of test and additional explanation

The testing results are in compliance with FCC part 22: 2009, FCC part 24: 2009 (see the continued pages)  
(Test date: 2011.06.08-2011.06.21)  
(Date of report: 2011.06.29)

本报告提供的结果仅对本次被测的样品有效。  
The data are valid only for the sample(s).

检测结果/说明（续页）：

Results of test and additional explanation (continued page)

Contents

1.	Test Summary.....	5
2.	General Information .....	6
2.1	EUT Description.....	6
2.2	Operational Description .....	6
2.3	Configuration of Tested System.....	7
2.4	General Information of Test Site .....	7
3.	Peak Output Power Test.....	8
3.1	Test setup .....	8
3.2	Limits.....	8
3.3	Test procedure.....	8
3.4	Test results .....	9
3.5	Test Instrumentation (Test date: 2011.06.17).....	15
3.6	Test Photograph .....	15
4.	Carrier Radiated Power Test.....	16
4.1	Test setup .....	16
4.2	Limits.....	16
4.3	Test procedure.....	16
4.4	Test results .....	18
4.5	Test Instrumentation (Test date: 2011.06.14).....	18
4.6	Test Photographs.....	19
5.	Occupied Bandwidth Test .....	22
5.1	Test setup .....	22
5.2	Limits.....	22
5.3	Test procedure.....	22
5.4	Test results .....	23
5.5	Test Instrumentation (Test date: 2011.06.17).....	29
5.6	Test Photograph .....	29
6.	Band Edge Test .....	30
6.1	Test setup .....	30
6.2	Limits.....	30
6.3	Test procedure.....	30
6.4	Test results .....	31
6.5	Test Instrumentation (Test date: 2011.06.15).....	35
6.6	Test Photograph .....	35
7.	Spurious Conducted Emission Test.....	36
7.1	Test setup .....	36
7.2	Limits.....	36
7.3	Test procedure.....	36
7.4	Test results .....	37
7.5	Test Instrumentation (Test date: 2011.06.15-2011.06.16).....	61

检测结果/说明（续页）：

Results of test and additional explanation (continued page)

7.6	Test Photograph .....	61
8.	Spurious Radiation Emission Test .....	62
8.1	Test setup .....	62
8.2	Limits.....	62
8.3	Test procedure.....	62
8.4	Test results .....	63
8.5	Test Instrumentation (Test date: 2011.06.08-2011.06.12).....	65
8.6	Test Photographs.....	66
9.	Frequency Deviation Test .....	69
9.1	Test setup .....	69
9.2	Limits.....	69
9.3	Test procedure.....	69
9.4	Test results .....	70
9.5	Test Instrumentation (Test date: 2011.06.09-2011.06.21).....	72
9.6	Test Photographs.....	72
	Attachment 1: Main measuring instruments used in this test .....	74
	Attachment 2: EUT photographs .....	76

检测结果/说明（续页）：

Results of test and additional explanation (continued page)

1. Test Summary

FCC Rule	Description of Test	Result
§ 2.1046 § 22.913 § 24.232	Peak Output Power	Pass
§ 22.913 § 24.232	Carrier Radiated Power	Pass
§ 2.1049 § 22.917 § 24.238(b)	Occupied Bandwidth	Pass
§ 2.1051 § 22.917 § 24.238(b)	Band Edge	Pass
§ 2.1051 § 22.917 § 24.238(b)	Spurious Conducted Emission	Pass
§ 2.1053 § 22.917 § 24.238(b)	Spurious Radiated Emission	Pass
§ 2.1046 § 22.355 § 24.235	Frequency Deviation	Pass

检测结果/说明（续页）：

Results of test and additional explanation (continued page)

2. General Information

2.1 EUT Description

Product Name	GPS Locator
Trade Name	Queclink
Model No.	GL100S
Type of modulation	GMSK
Antenna type	Soldered on PCB
Tx Frequency	824MHz~869MHz (GPRS 850) 1850MHz ~ 1910MHz (GPRS 1900)
Rx Frequency	869MHz~894MHz (GPRS 850) 1930MHz ~ 1990MHz (GPRS 1900)
Channel bandwidth	200kHz
FCC ID	YQD-GL100S

2.2 Operational Description

SIMT EMC has verified the construction and function in typical operation. All the test modes were carried out with the EUT in normal operation, which was shown in this test report and defined as:

Test Mode	GPRS 850 (class 10, 2up, 3down)
	GPRS 1900 (class 10, 2up, 3down)

检测结果/说明 (续页):

Results of test and additional explanation (continued page)

## 2.3 Configuration of Tested System

### (1) Configuration of Radiated measurement

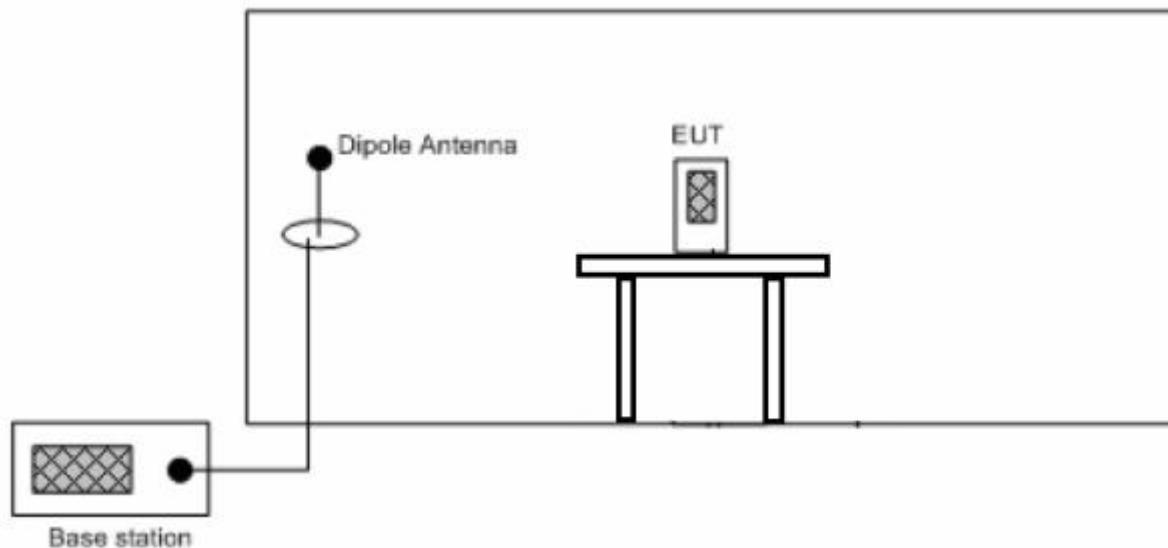

### (2) Configuration of Conducted measurement

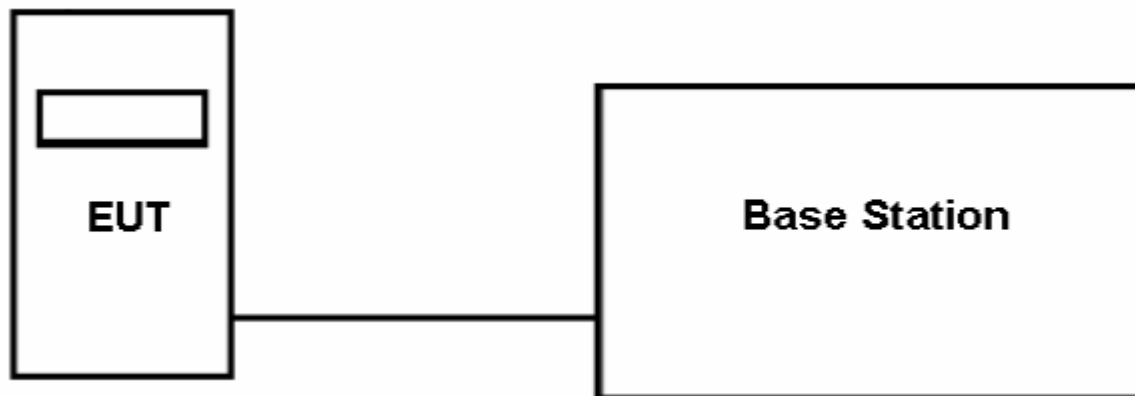

## 2.4 General Information of Test Site

Site Name: SIMT EMC Lab.

Site Address: 716 Yi Shan Road. Shanghai. China

Tel: 8621-6470-1390 / Fax: 8621-6451-4252

E-Mail: [EMC@SIMT.com.cn](mailto:EMC@SIMT.com.cn)

检测结果/说明（续页）：  
Results of test and additional explanation (continued page)

### 3. Peak Output Power Test

#### 3.1 Test setup

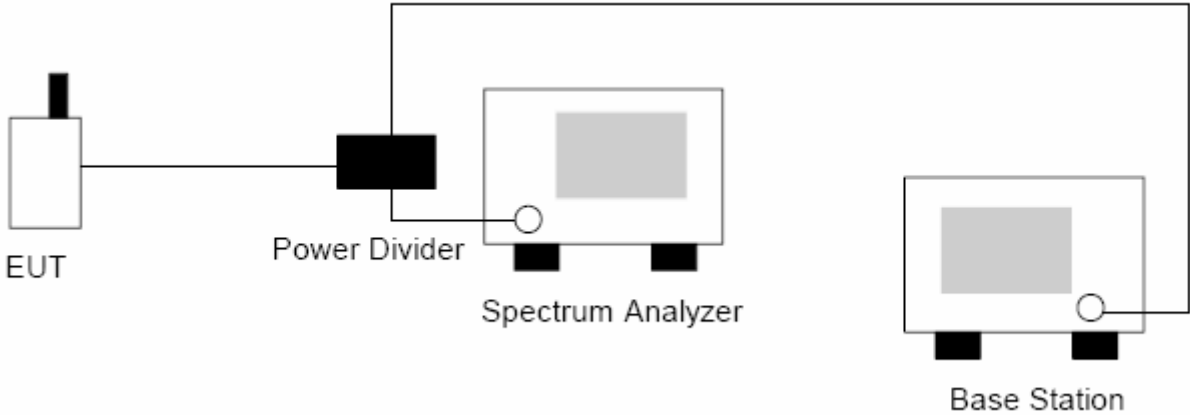

#### 3.2 Limits

No specific requirement.

#### 3.3 Test procedure

After a radio link has been established between EUT and Base station, the output power of the cell signal of the testing equipment will be decreased until the output power of the EUT reach a maximum value. Then the test data can be read at the tester screen. The loss between RF output port of the EUT and the input port of the tester will be taken into consideration. The measurement will be conducted at three channels Bottom, middle and top channels.



检测结果/说明 (续页):

Results of test and additional explanation (continued page)

3.4 Test results

Test mode: GPRS 850 (class 10, 2up, 3down)		Power source: DC: 3.7V	
Test Frequency (MHz)	Cable Loss (dB)	Carrier Power (dBm)	Test results
824.2 (channel 128)	16.12	32.16	Pass
836.4 (channel 189)	16.12	32.17	Pass
848.8 (channel 251)	16.13	32.15	Pass

824.2MHz (channel 128)

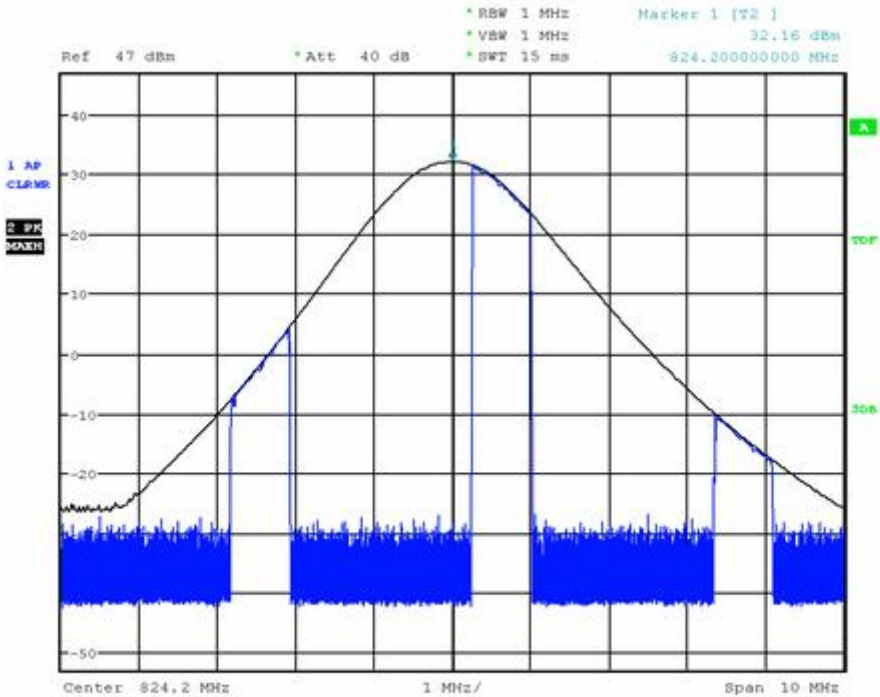

Date: 16.JUN.2011 09:18:56

检测结果/说明 (续页):

Results of test and additional explanation (continued page)

836.4MHz (channel 189)

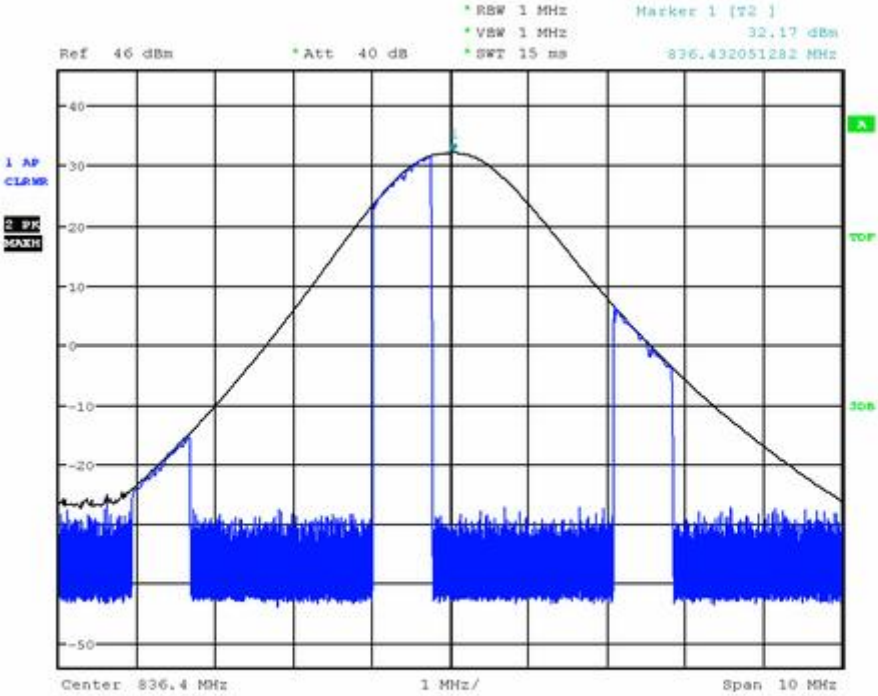

Date: 16.JUN.2011 09:19:35

检测结果/说明 (续页):

Results of test and additional explanation (continued page)

848.8MHz (channel 251)

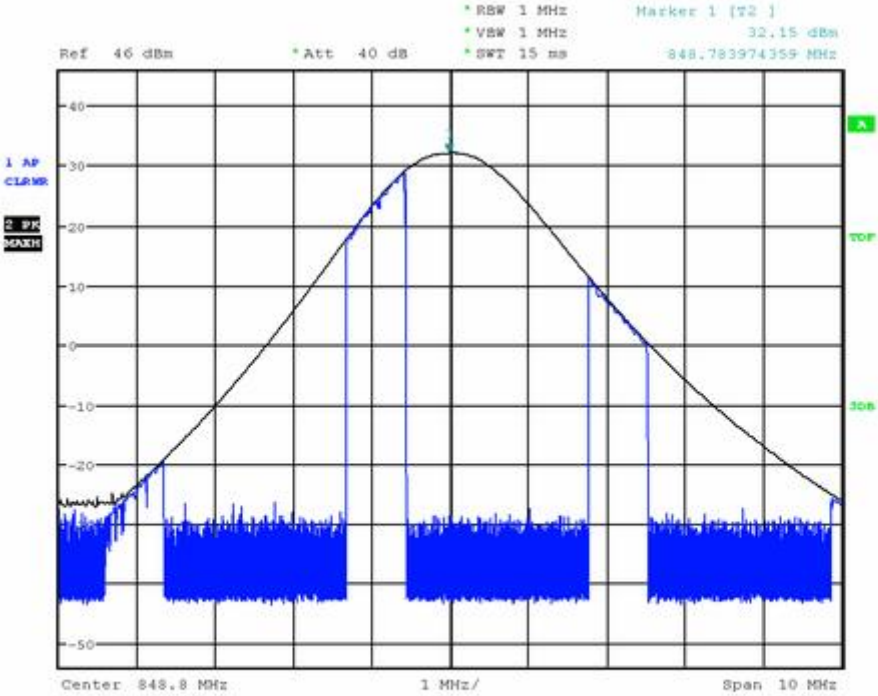

Date: 16.JUN.2011 09:20:09

检测结果/说明 (续页):

Results of test and additional explanation (continued page)

Test mode: GPRS 1900 (class 10, 2up, 3down)		Power source: DC: 3.7V	
Test Frequency (MHz)	Cable Loss (dB)	Carrier Power (dBm)	Test results
1850.2 (channel 512)	16.18	28.59	Pass
1880.0 (channel 661)	16.19	28.31	Pass
1909.8 (channel 810)	16.21	28.39	Pass

1850.2MHz (channel 512)

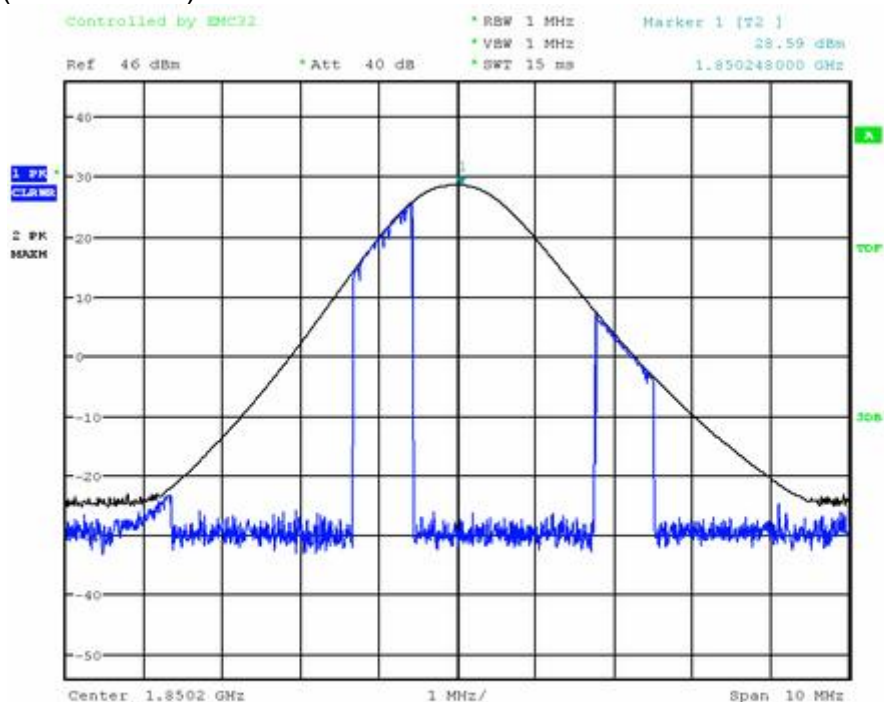

Date: 15.JUN.2011 05:45:39

检测结果/说明 (续页):

Results of test and additional explanation (continued page)

1880.0MHz (channel 661)

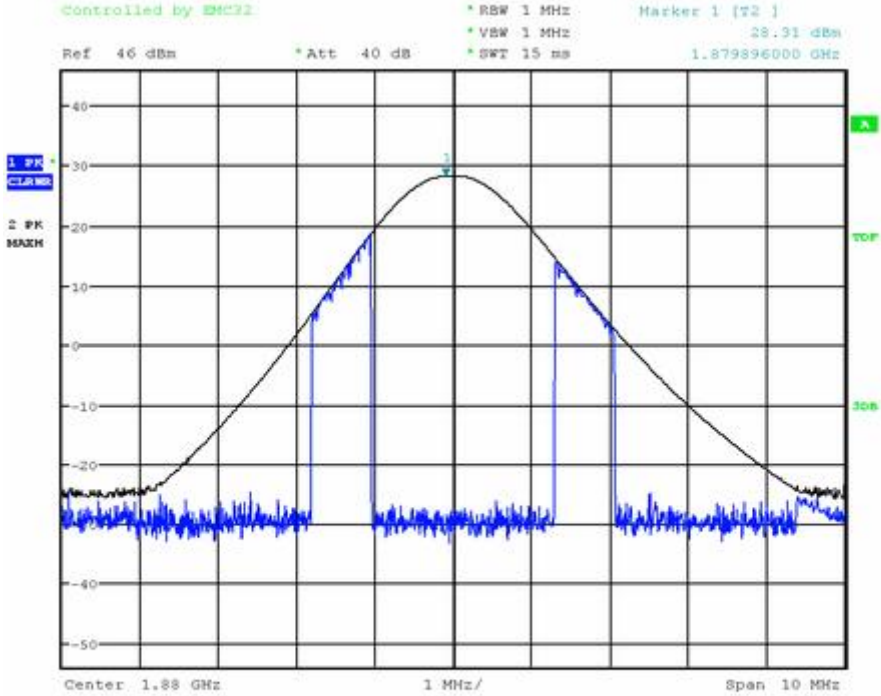

Date: 15.JUN.2011 05:47:18

检测结果/说明 (续页):

Results of test and additional explanation (continued page)

1909.8MHz (channel 810)

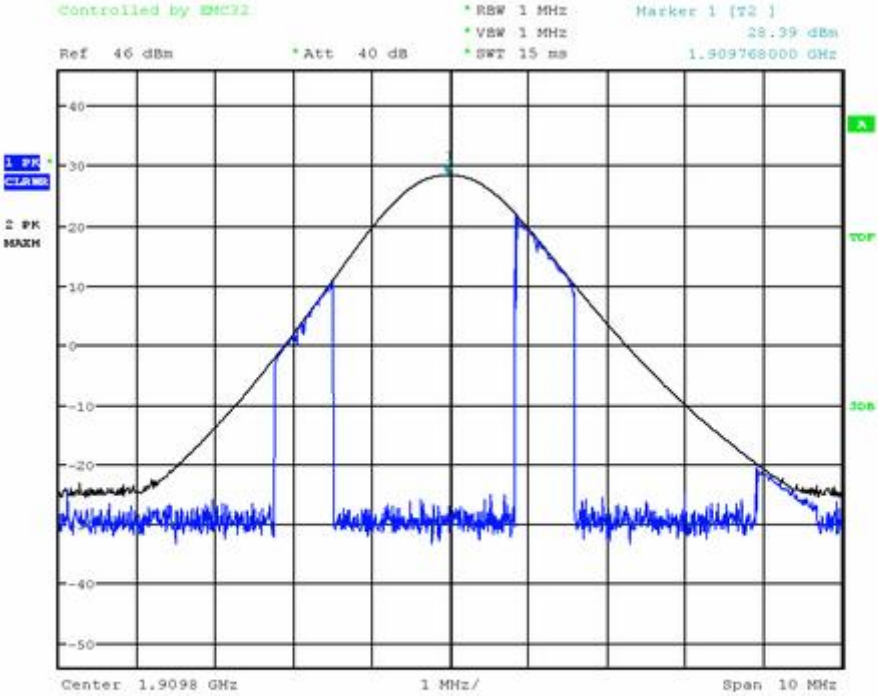

Date: 15.JUN.2011 05:49:37

检测结果/说明（续页）：

Results of test and additional explanation (continued page)

3.5 Test Instrumentation (Test date: 2011.06.17)

Name/Model	Number	Due date
Universal Radio Communication Tester / CMU 200	容-026-01	2011.06.22
Spectrum Analyzer / FSU 26	容-026-45	2011.12.05
Power Splitter / 11667C	容-030-11	2011.07.21

3.6 Test Photograph

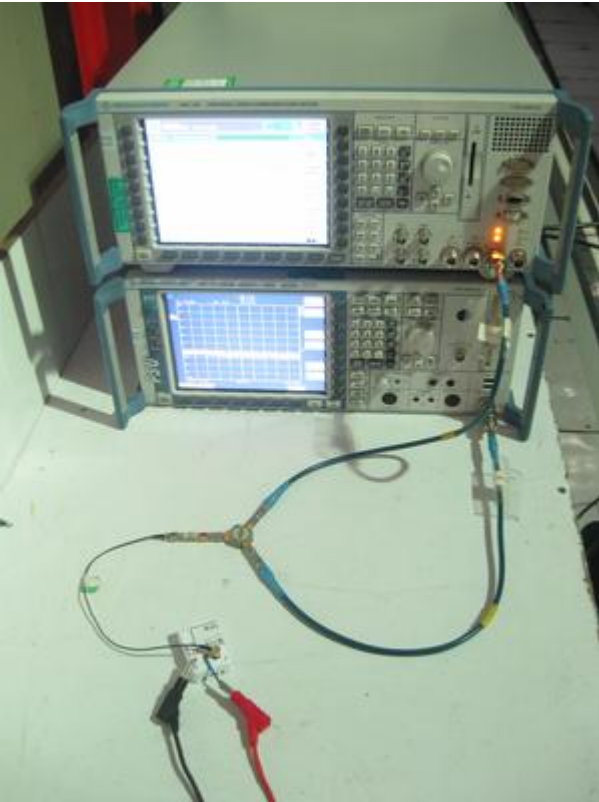

检测结果/说明（续页）：

Results of test and additional explanation (continued page)

4. Carrier Radiated Power Test

4.1 Test setup

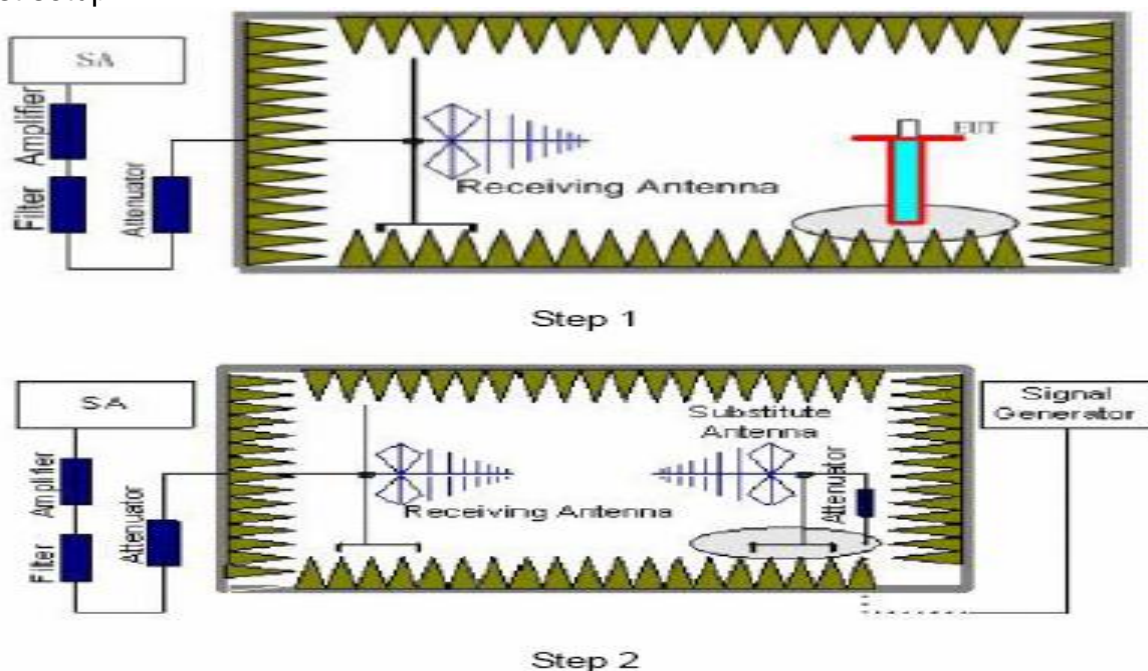

4.2 Limits

GPRS 850	E.R.P<38.5dBm
GPRS 1900	E.I.R.P<33.0dBm

4.3 Test procedure

Step 1:

EUT was placed on a 1.5 meters high non-conductive table in a fully anechoic chamber. A receiving antenna was placed on the antenna mast 3 meters from the EUT. The height of receiving antenna is 1.5m. A radio link shall be established between EUT and Tester. The output power of the cell signal of the tester will be decreased until the output power of the EUT reach a maximum value. A Peak detector is used and RBW is set to 1MHz. Then turn table rotation is adjusted from 0 degree to 360 degree until the maximum power value is founded on spectrum analyzer or receiver.

Step 2:

A log-periodic antenna or double-ridged waveguide horn antenna shall be substituted in place of the EUT. The antenna will be driven by a signal generator and the level will be adjusted till the same power value on the spectrum analyzer or receiver. The EIRP or ERP of the EUT can be calculated through the level of the signal generator, cable loss, the gain of the substitution antenna and the reading value of the spectrum analyzer or receiver.



检测结果/说明（续页）：

Results of test and additional explanation (continued page)

Step 3:

Calculation:  $ERP/EIRP = P_s + E_t - E_s + G_s = P_s + R_t - R_s + G_s$

$P_s$  (dBm): Input power to substitution antenna.

$P_s = PG - L_c$

$PG$  (dBm): output level of Signal generator

$L_c$  (dB) : Loss of the cable from Signal generator to substitution antenna

$G_s$  (dBi or dBd): Substitution antenna Gain.

$E_t = R_t + AF$

$E_s = R_s + AF$

$AF$  (dB/m): Receive antenna factor

$R_t$ : The highest received signal in Spectrum Analyzer for EUT.

$R_s$ : The highest received signal in spectrum analyzer for substitution antenna.

According to the Step 1 and Step 2,  $R_t = R_s$   $ERP/EIRP = PG - L_c + G_s$

检测结果/说明（续页）：

Results of test and additional explanation (continued page)

4.4 Test results

Test mode: GPRS 850 (class 10, 2up, 3down)				Power source: DC 3.7V	
Test Frequency (MHz)	Generator output (dBm)	Cable Loss (dB)	Antenna gain (dBd)	Carrier radiated power (ERP) (dBm)	Test results
824.2 (channel 128)	21.56	1.69	5.20	25.07	Pass
836.4 (channel 189)	20.66	1.70	5.18	24.14	Pass
848.8 (channel 251)	20.70	1.71	5.15	24.14	Pass

Test mode: GPRS 1900 (class 10, 2up, 3down)				Power source: DC 3.7V	
Test Frequency (MHz)	Generator output (dBm)	Cable Loss (dB)	Antenna gain (dBi)	Carrier radiated power (EIRP) (dBm)	Test results
1850.2 (channel 512)	17.59	2.54	10.12	25.17	Pass
1880.0 (channel 661)	17.80	2.56	10.08	25.32	Pass
1909.8 (channel 810)	18.35	2.60	10.04	25.79	Pass

4.5 Test Instrumentation (Test date: 2011.06.14)

Name/Model	Number	Due date
Microwave Signal Generator / SMR 20	容-001-02	2012.01.06
Ultra Broadband Antenna / HL 562	容-001-03	2012.06.13
Double-Ridged Waveguide Horn Antenna / HF 906	容-001-04	2012.06.16
Spectrum Analyzer / FSU 26	容-001-33	2011.06.24
VHA 9103 without telescopic rods for use with biconical broad-band elements BBA 9106 / BBA 9106 + VHA 9103	容-001-39	2012.06.13
Logarithmic Periodic Broadband Antenna / UHALP 9108 A	容-001-40	2012.06.13
Universal Radio Communication Tester / CMU 200	容-026-01	2011.06.22
Double-Ridged Waveguide Horn Antenna / 3115	容-030-03	2011.06.17

检测结果/说明（续页）：  
Results of test and additional explanation (continued page)

4.6 Test Photographs



检测结果/说明（续页）：  
Results of test and additional explanation (continued page)

X orientation



Y orientation



检测结果/说明（续页）：  
Results of test and additional explanation (continued page)

Z orientation



检测结果/说明（续页）：

Results of test and additional explanation (continued page)

## 5. Occupied Bandwidth Test

### 5.1 Test setup

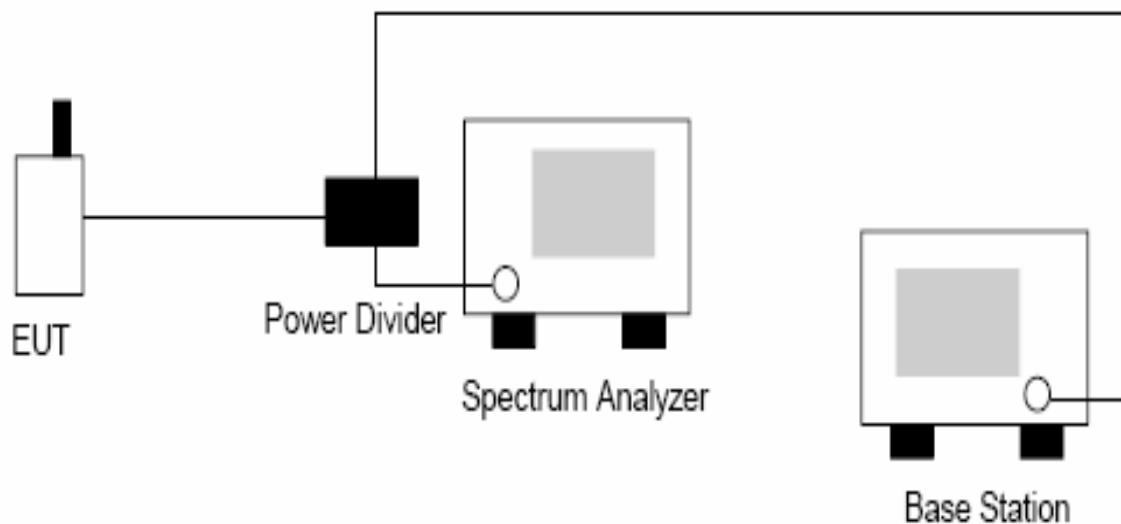

### 5.2 Limits

No specific occupied bandwidth requirements.

### 5.3 Test procedure

After a radio link has been established between EUT and Tester, the output power of the cell signal of the testing equipment will be decreased until the output power of the EUT reach a maximum value. The occupied bandwidth is measured using spectrum analyzer. RBW is set to 3 kHz on spectrum analyzer. The bandwidth of 99% power can be read on spectrum analyzer. The measurement will be conducted at Bottom, middle and top three channels.

检测结果/说明 (续页):

Results of test and additional explanation (continued page)

5.4 Test results

Test mode: GPRS 850 (class 10, 2up, 3down)		
Power source: DC 3.7V		
Test Frequency (MHz)	Test level (kHz)	Test results
824.2 (channel 128)	246.8	Pass
836.4 (channel 189)	242.0	Pass
848.8 (channel 251)	243.6	Pass

824.2 MHz (channel 128)

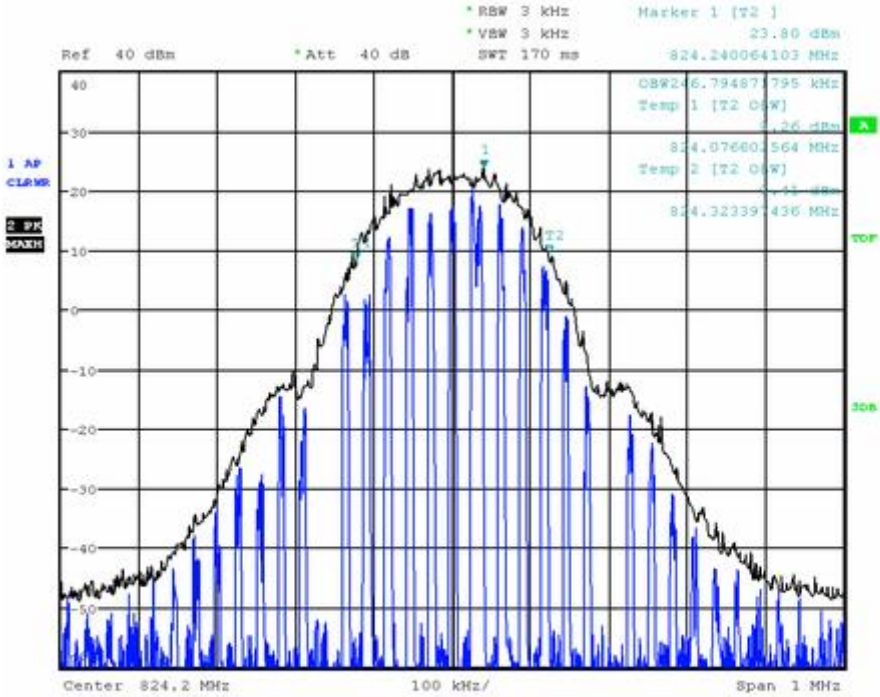

Date: 16.JUN.2011 09:27:33

检测结果/说明 (续页):

Results of test and additional explanation (continued page)

836.4MHz (channel 189)

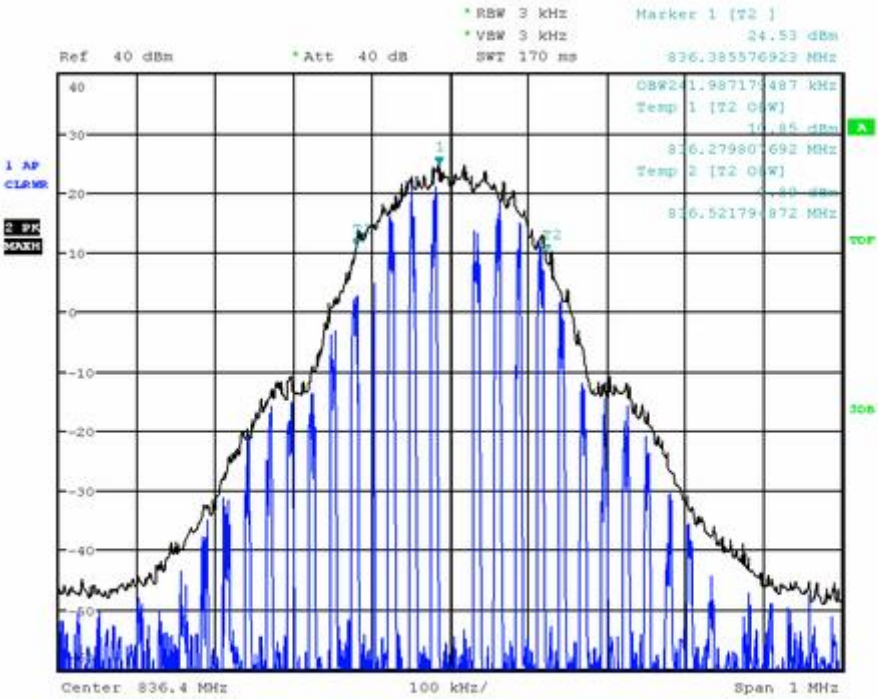

Date: 16.JUN.2011 09:26:23



检测结果/说明 (续页):

Results of test and additional explanation (continued page)

848.8MHz (channel 251)

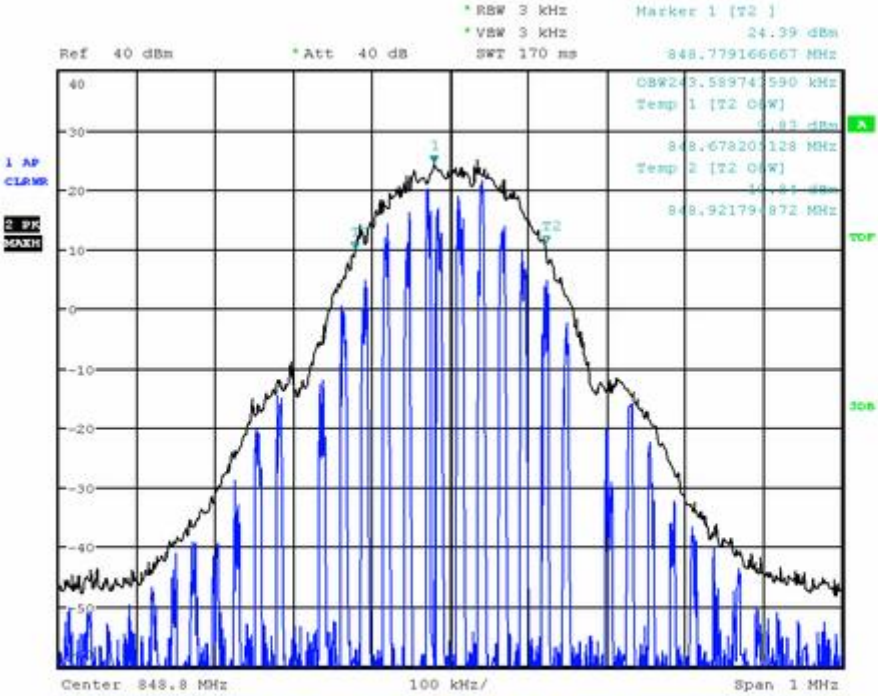

Date: 16 JUN 2011 09:24:32

检测结果/说明 (续页):

Results of test and additional explanation (continued page)

Test mode: GPRS 1900 (class 10, 2up, 3down)		
Power source: DC 3.7V		
Test Frequency (MHz)	Test level (kHz)	Test results
1850.2 (channel 512)	245.6	Pass
1880.0 (channel 661)	244.8	Pass
1909.8 (channel 810)	243.2	Pass

1850.2MHz (channel 512)

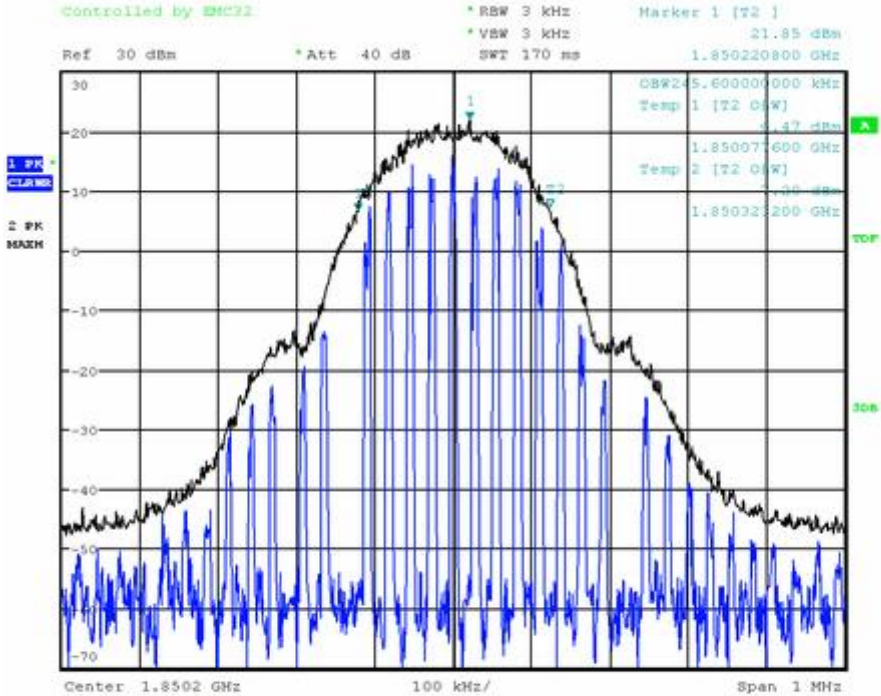

Date: 15.JUN.2011 07:12:08

检测结果/说明 (续页):

Results of test and additional explanation (continued page)

1880.0MHz (channel 661)

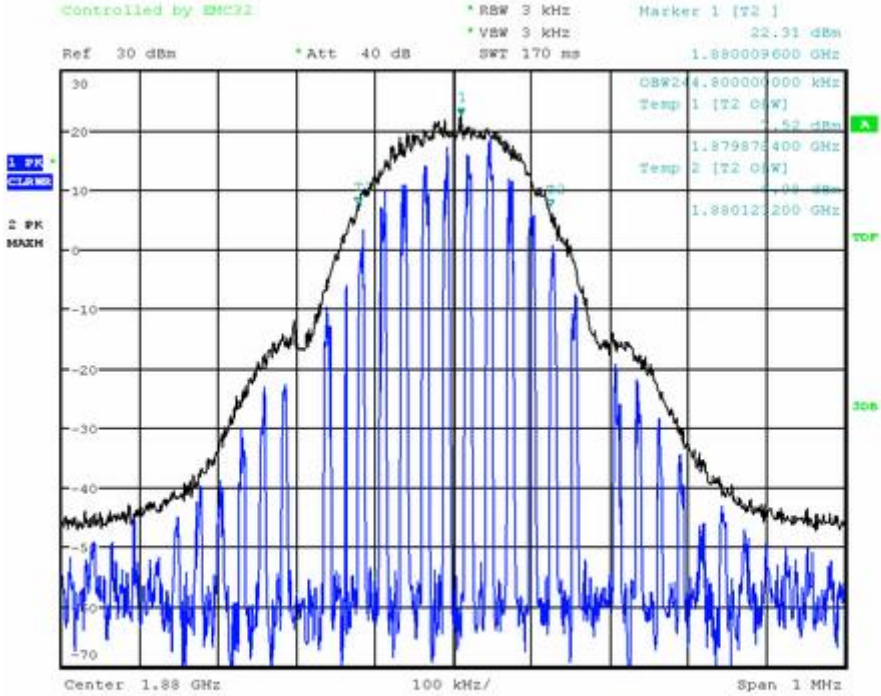

Date: 15.JUN.2011 07:19:08

检测结果/说明 (续页):

Results of test and additional explanation (continued page)

1909.8MHz (channel 810)

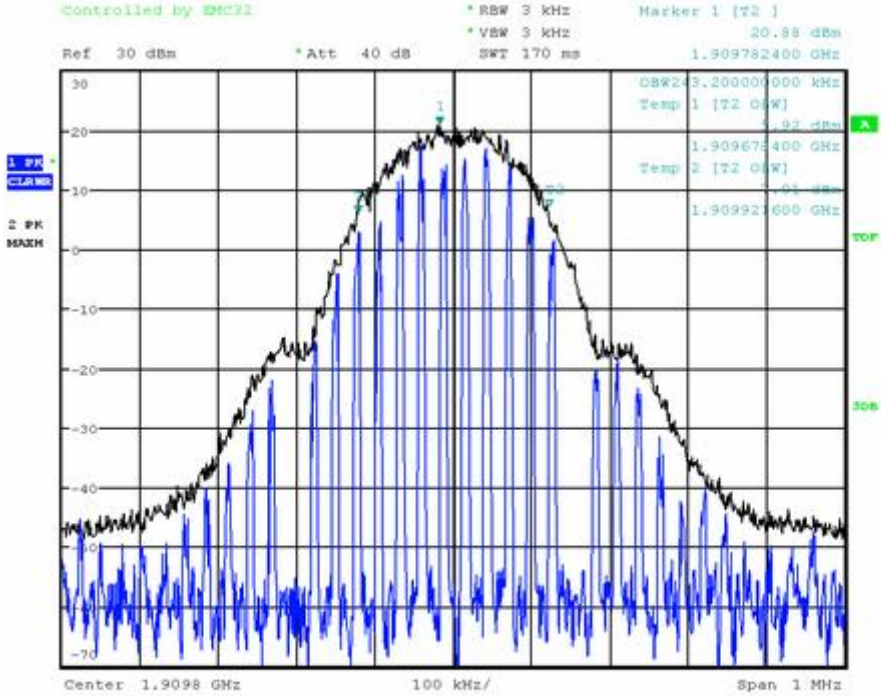

Date: 15.JUN.2011 07:20:39

检测结果/说明（续页）：

Results of test and additional explanation (continued page)

5.5 Test Instrumentation (Test date: 2011.06.17)

Name/Model	Number	Due date
Universal Radio Communication Tester / CMU 200	容-026-01	2011.06.22
Spectrum Analyzer / FSU 26	容-026-45	2011.12.05
Power Splitter / 11667C	容-030-11	2011.07.21

5.6 Test Photograph

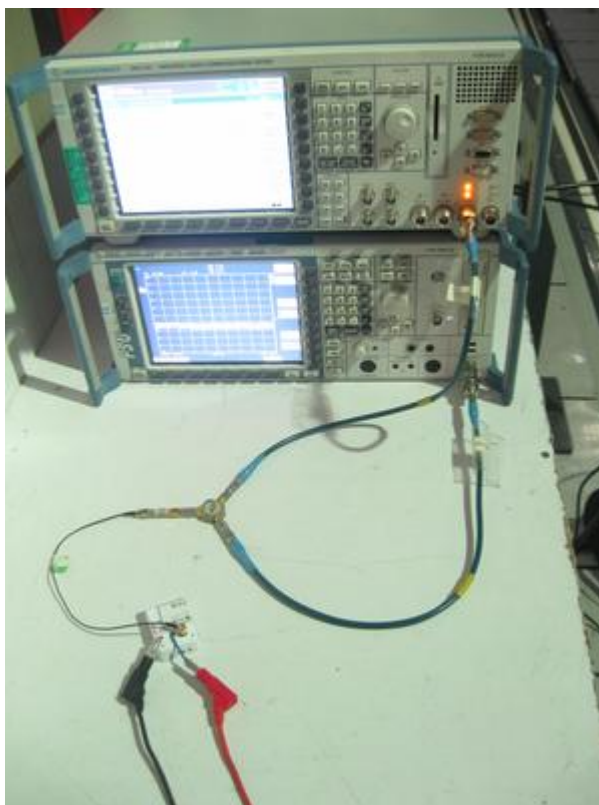

检测结果/说明 (续页):  
Results of test and additional explanation (continued page)

### 6. Band Edge Test

#### 6.1 Test setup

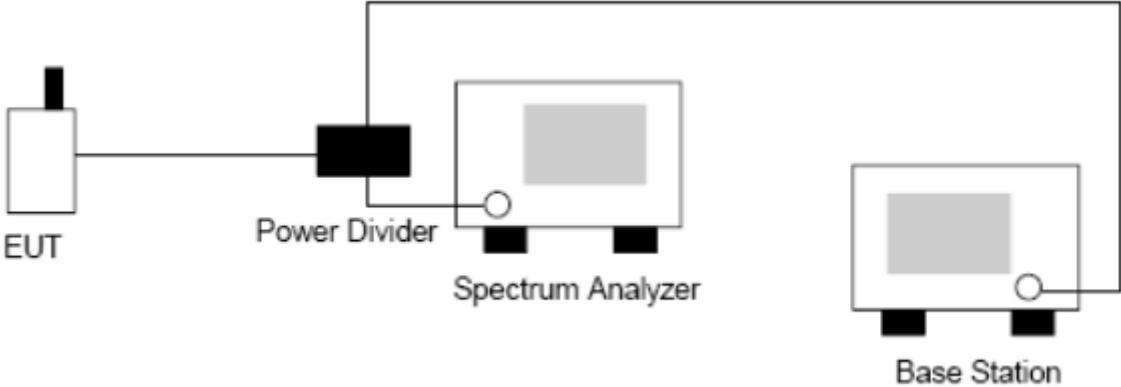

#### 6.2 Limits

Limits	<-13dBm
--------	---------

#### 6.3 Test procedure

After a radio link has been established between EUT and Tester, the output power of the cell signal of the testing equipment will be increased until the output power of the EUT reach a maximum value. In the first 1.0 MHz band immediately outside and adjacent to the licensee's frequency block, the power of emissions per any 1% of the emission bandwidth shall be attenuated below the transmitter output power P (in watts) by at least  $43 + 10 \log(P)$ .

检测结果/说明 (续页):

Results of test and additional explanation (continued page)

6.4 Test results

Test mode: GPRS 850 (class 10, 2up, 3down)			
Power source: DC 3.7V			
Item	Test Frequency (MHz)	Test level (dBm)	Test results
Right band edge	848.8 (channel 251)	-13.54	Pass
Left band edge	824.2 (channel 128)	-13.97	Pass

Right band edge, 848.8MHz (channel 251)

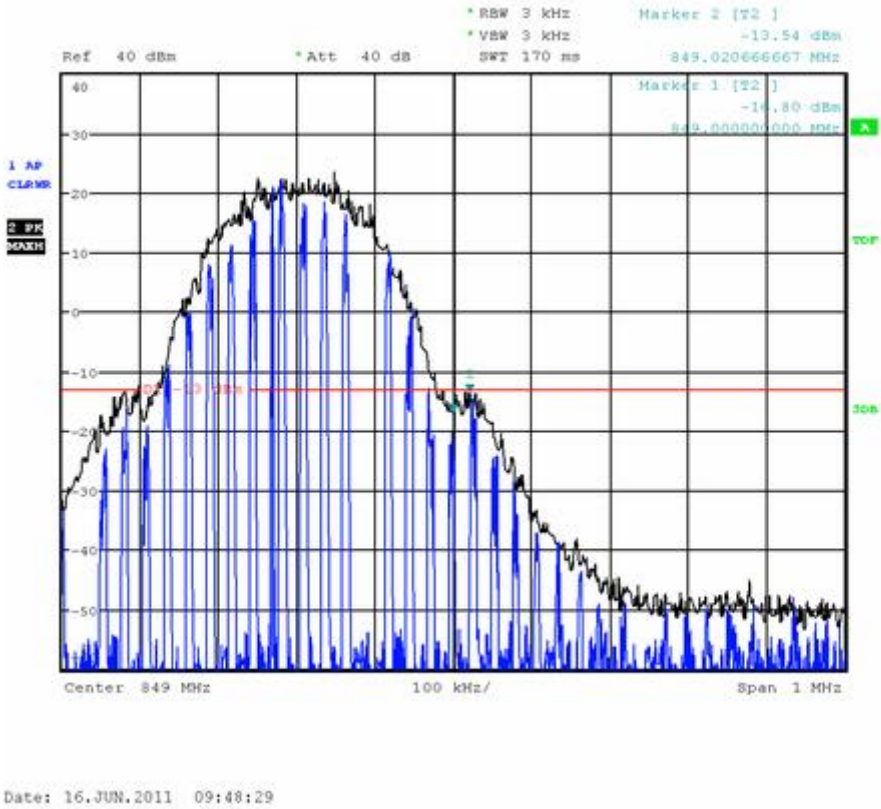

检测结果/说明 (续页):

Results of test and additional explanation (continued page)

Left band edge, 824.2MHz (channel 128)

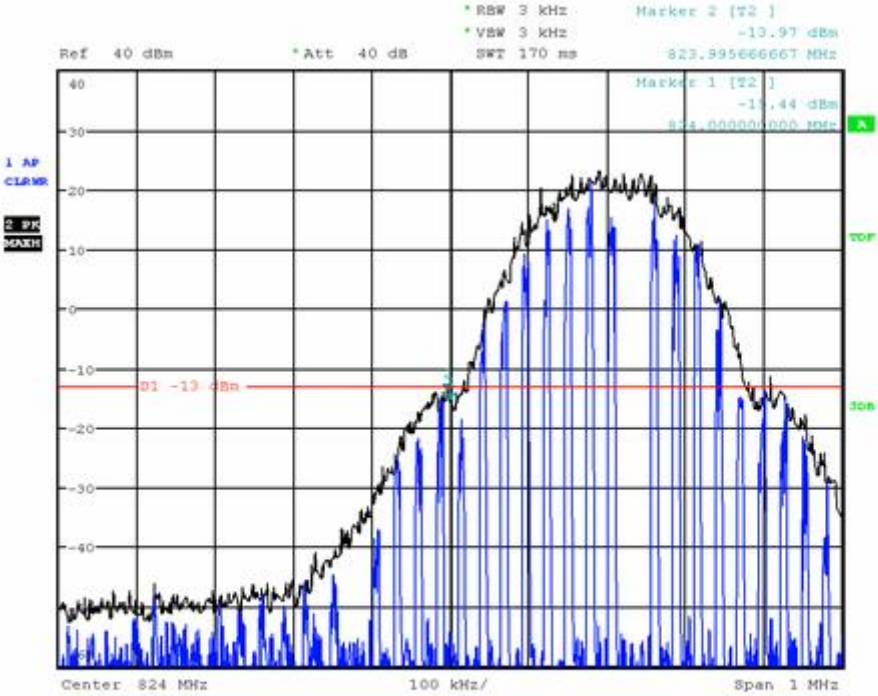

Date: 16.JUN.2011 09:52:49



检测结果/说明 (续页):

Results of test and additional explanation (continued page)

Test mode: GPRS 1900 (class 10, 2up, 3down)			
Power source: DC 3.7V			
Item	Test Frequency (MHz)	Test level (dBm)	Test results
Right band edge	1909.8 (channel 810)	-15.20	Pass
Left band edge	1850.2 (channel 512)	-15.45	Pass

Right band edge, 1909.8MHz (channel 810)

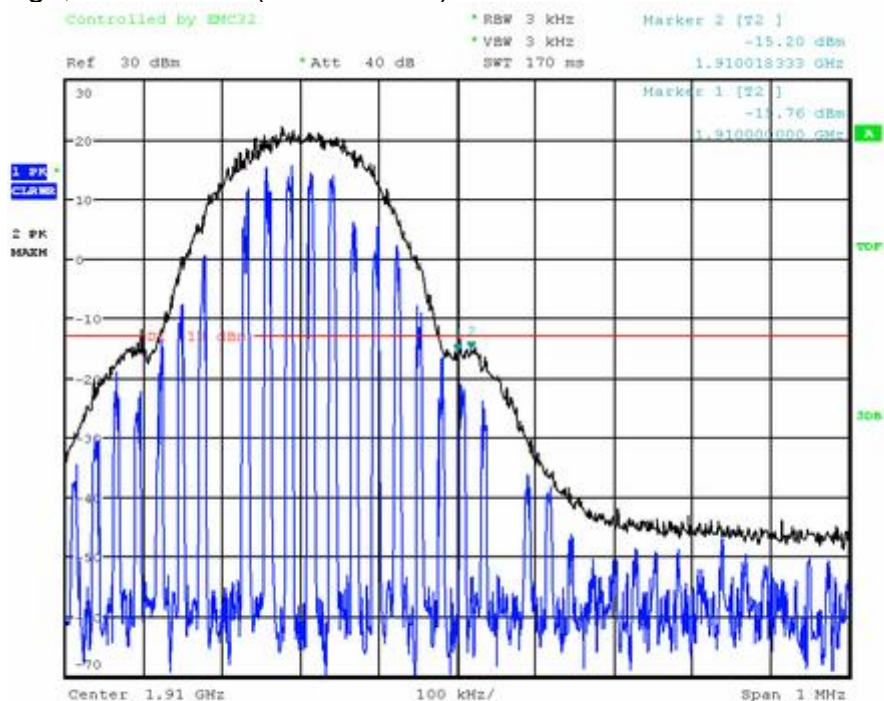

Date: 15.JUN.2011 07:56:25

检测结果/说明 (续页):

Results of test and additional explanation (continued page)

Left band edge, 1850.2MHz (channel 512)

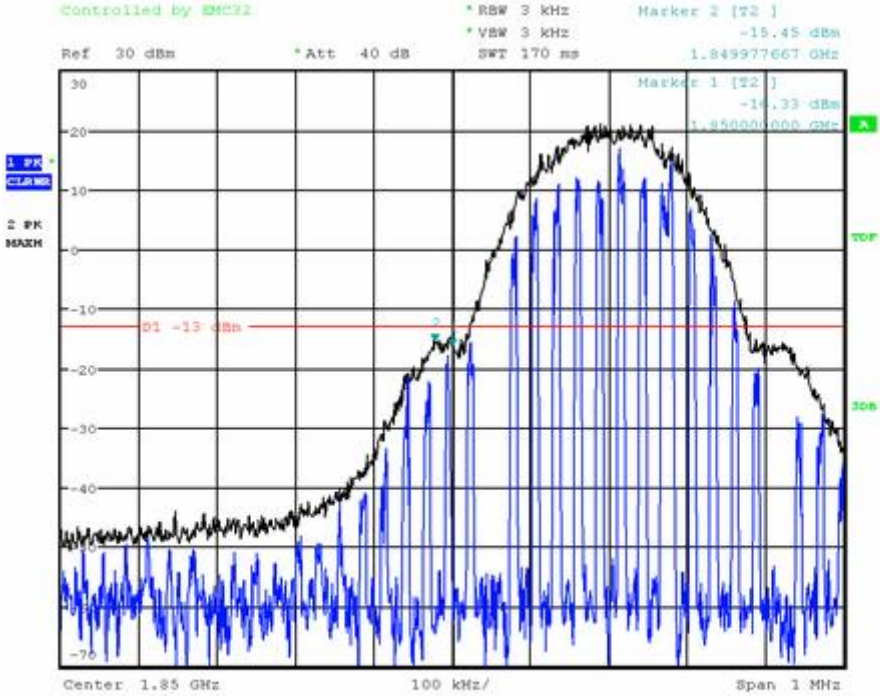

Date: 15.JUN.2011 07:58:24

检测结果/说明（续页）：

Results of test and additional explanation (continued page)

6.5 Test Instrumentation (Test date: 2011.06.15)

Name/Model	Number	Due date
Spectrum Analyzer / FSU 26	容-026-45	2011.12.05
Power Splitter / 11667C	容-030-11	2011.07.21
Universal Radio Communication Tester / CMU 200	容-026-48	2011.11.23

6.6 Test Photograph



检测结果/说明（续页）：

Results of test and additional explanation (continued page)

7. Spurious Conducted Emission Test

7.1 Test setup

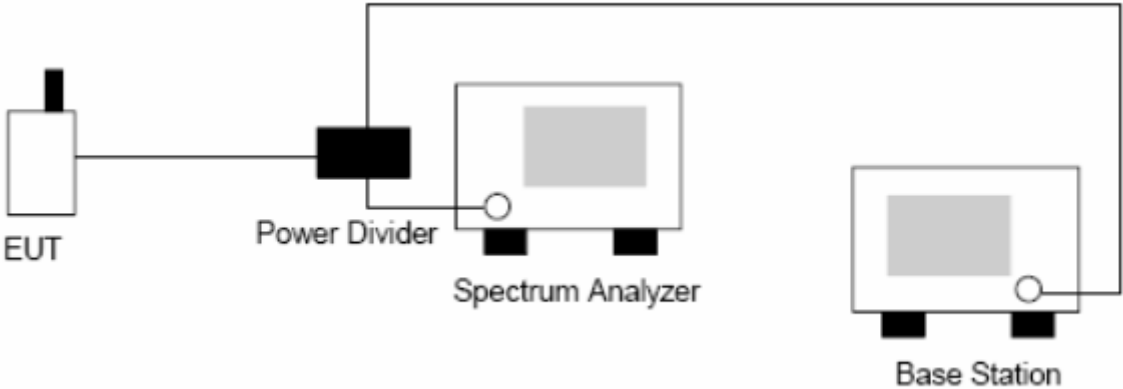

7.2 Limits

Limits	<-13dBm
--------	---------

7.3 Test procedure

The EUT was connected to Spectrum Analyzer and Base Station via power divider. The middle channel for the highest RF power within the transmitting frequency was measured. The conducted spurious emission for the whole frequency range was taken.

检测结果/说明 (续页):

Results of test and additional explanation (continued page)

7.4 Test results

Power source: DC 3.7V

7.4.1 Test mode: GPRS 850 (class 10, 2up, 3down)  
824.2MHz (channel 128), (20~30)MHz

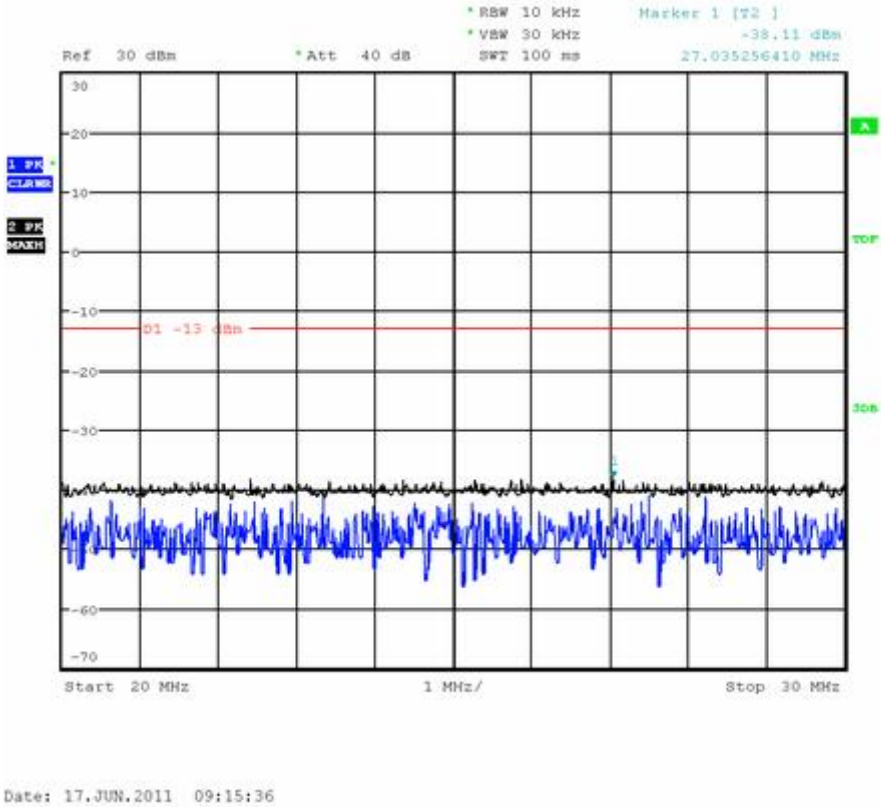

检测结果/说明 (续页):

Results of test and additional explanation (continued page)

824.2MHz (channel 128), (30~1000)MHz.

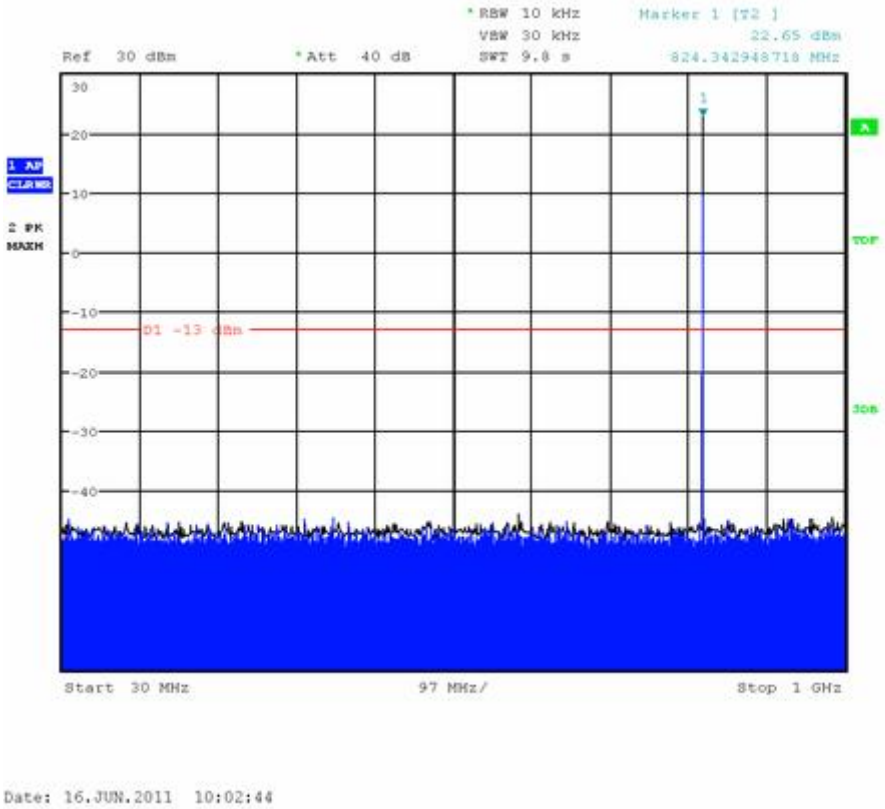

Note: The signal beyond the limit is carrier

检测结果/说明 (续页):

Results of test and additional explanation (continued page)

824.2MHz (channel 128), (1000~6000)MHz

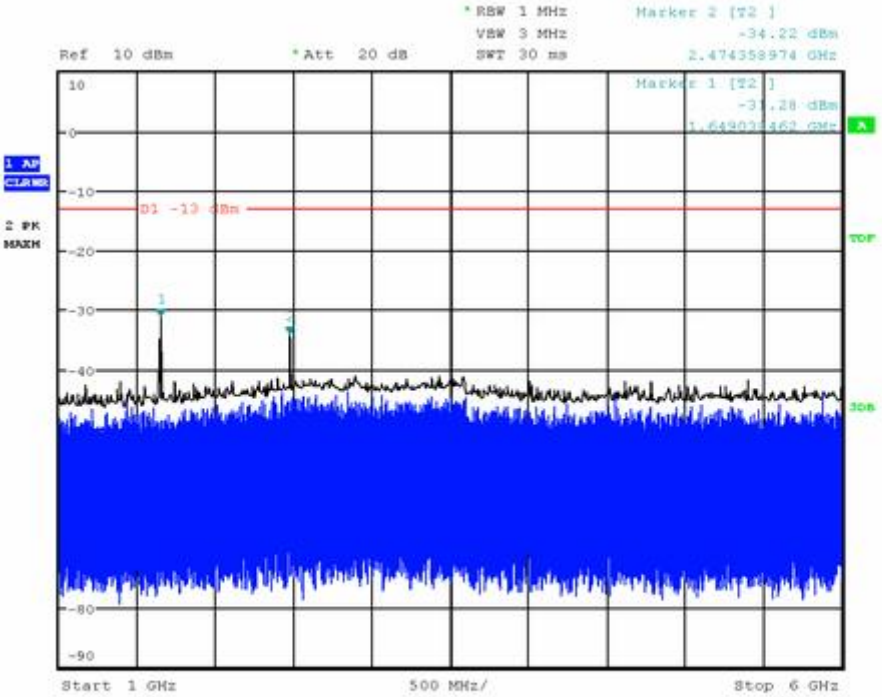

Date: 16, JUN. 2011 10:09:53

检测结果/说明 (续页):

Results of test and additional explanation (continued page)

824.2MHz (channel 128), (6000~20000)MHz

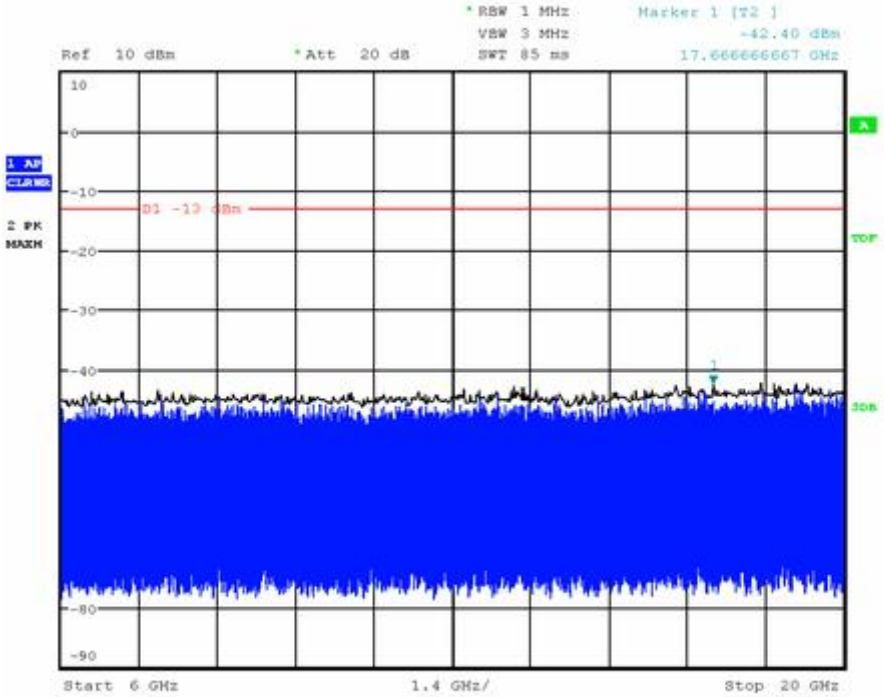

Date: 16, JUN. 2011 10:17:24



检测结果/说明 (续页):

Results of test and additional explanation (continued page)

836.4MHz (channel 189), (20~30)MHz

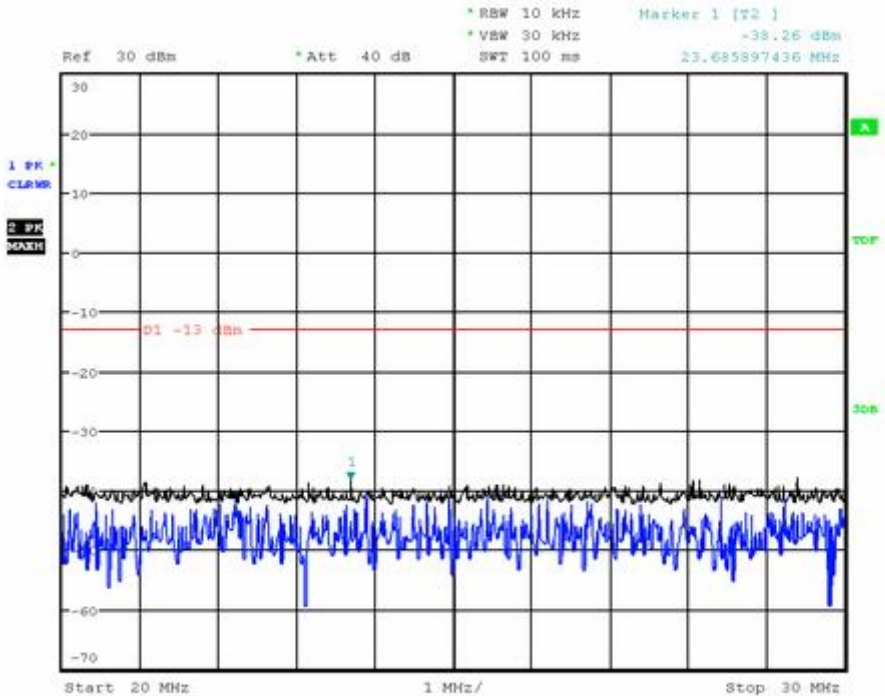

Date: 17.JUN.2011 09:16:57

检测结果/说明 (续页):

Results of test and additional explanation (continued page)

836.4MHz (channel 189), (30~1000)MHz

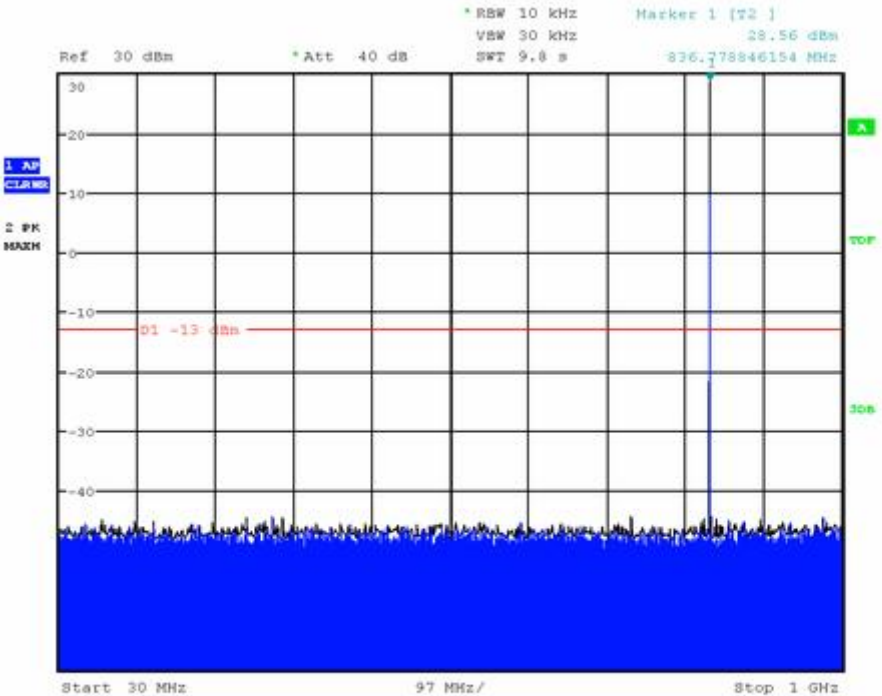

Date: 16.JUN.2011 10:07:04

Note: The signal beyond the limit is carrier

检测结果/说明 (续页):

Results of test and additional explanation (continued page)

836.4MHz (channel 189), (1000~6000)MHz

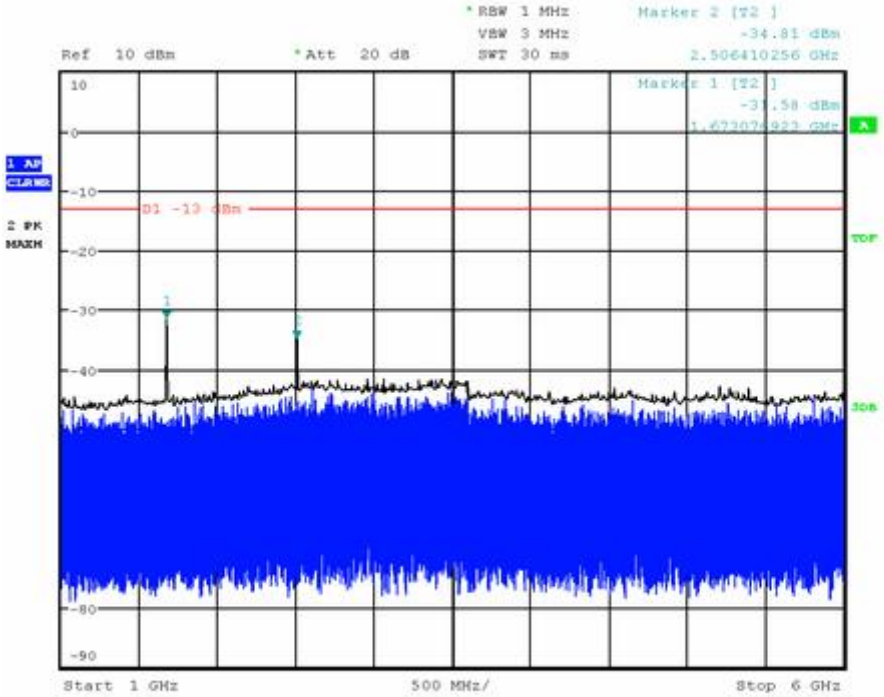

Date: 16.JUN.2011 10:11:10

检测结果/说明 (续页):

Results of test and additional explanation (continued page)

836.4MHz (channel 189), (6000~20000)MHz

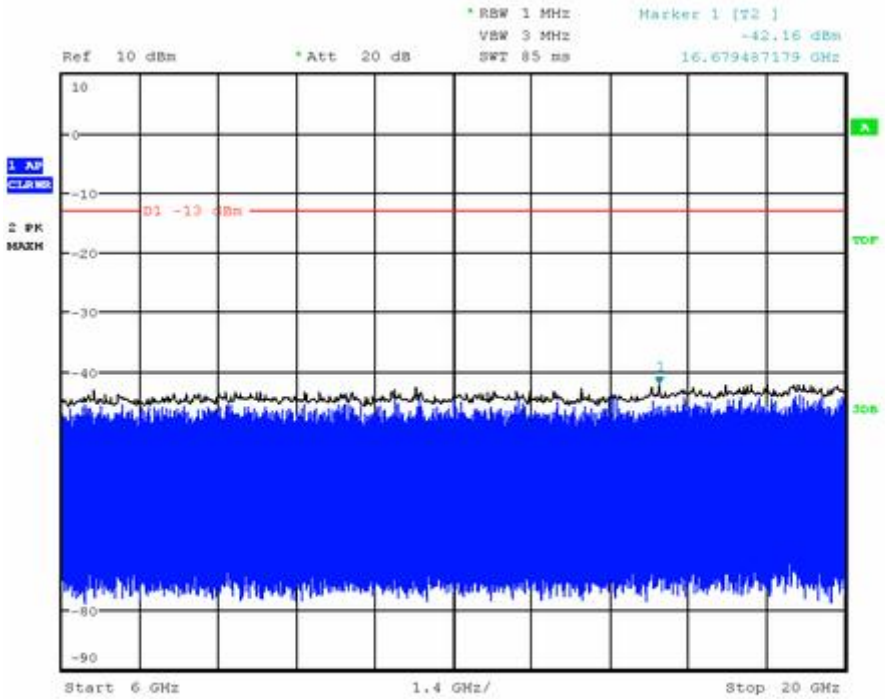

Date: 16.JUN.2011 10:16:54

检测结果/说明 (续页):

Results of test and additional explanation (continued page)

848.8MHz (channel 251), (20~30)MHz

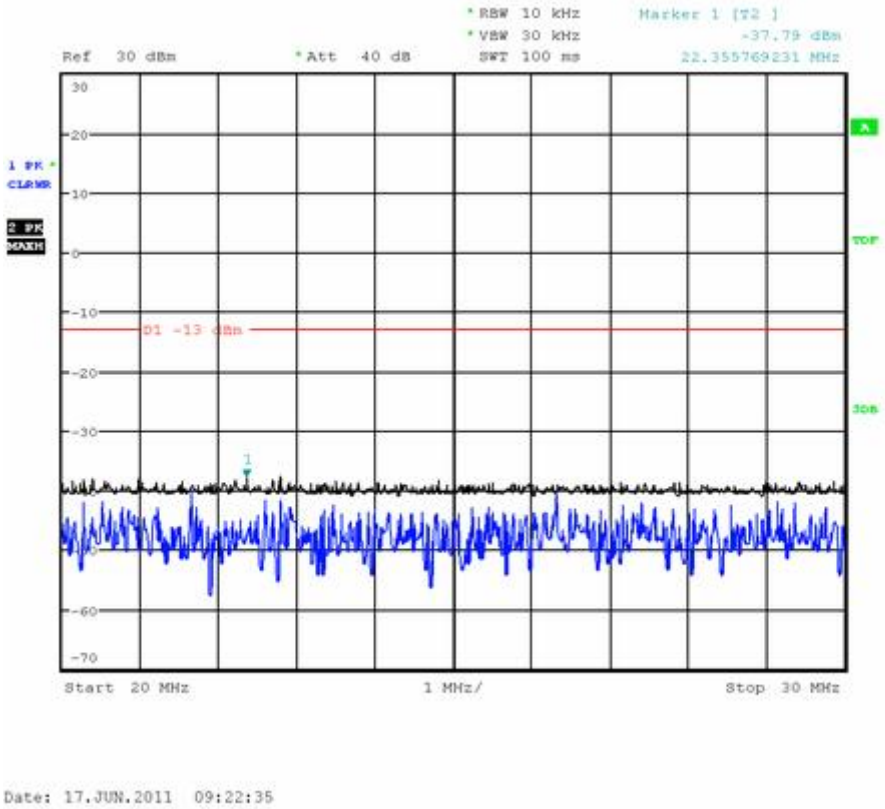

检测结果/说明 (续页):

Results of test and additional explanation (continued page)

848.8MHz (channel 251), (30~1000)MHz

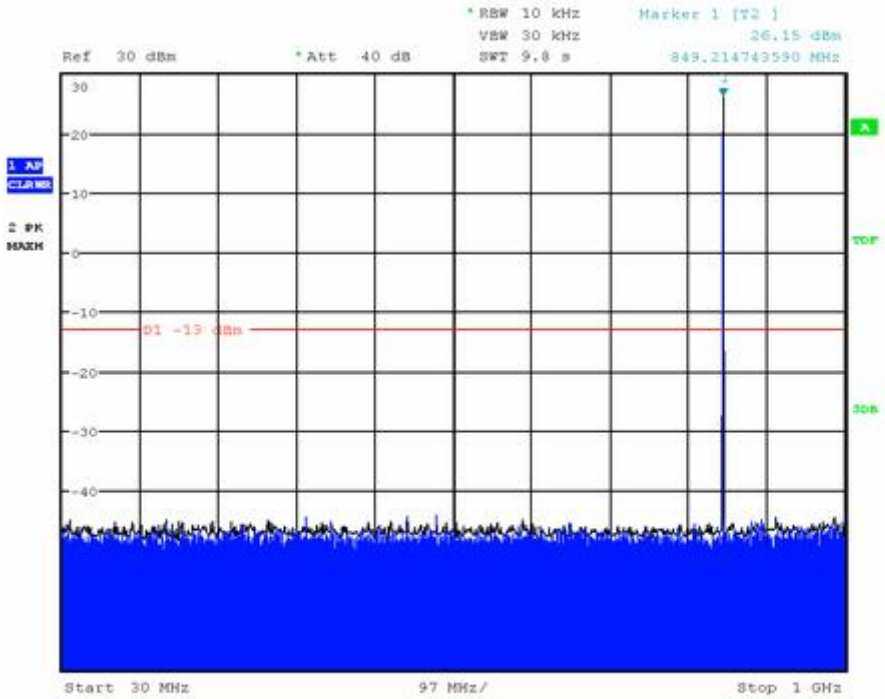

Date: 16.JUN.2011 10:05:27

Note: The signal beyond the limit is carrier

检测结果/说明 (续页):

Results of test and additional explanation (continued page)

848.8MHz (channel 251), (1000~6000)MHz

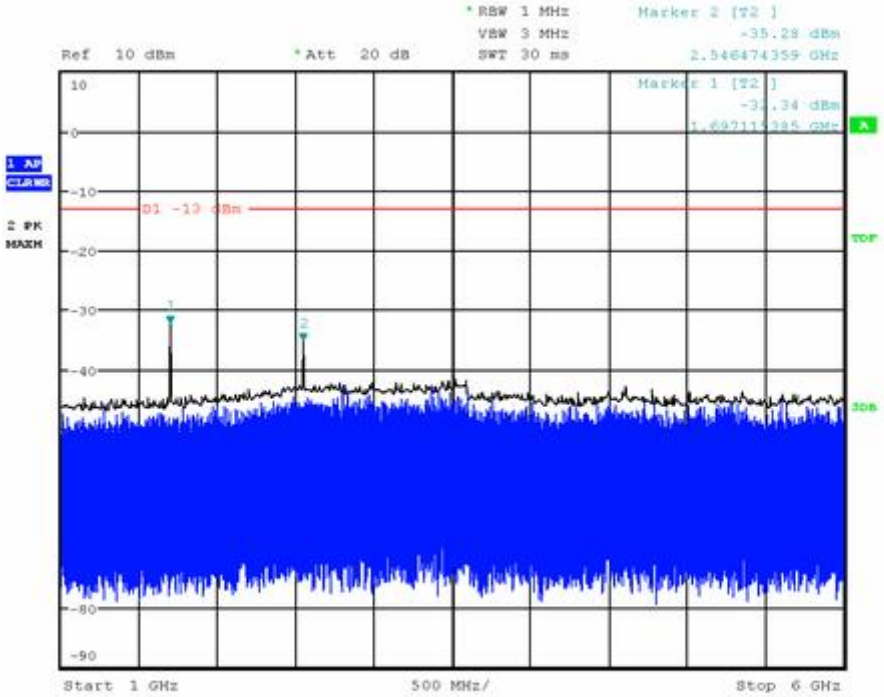

Date: 16.JUN.2011 10:11:56

检测结果/说明 (续页):

Results of test and additional explanation (continued page)

848.8MHz (channel 251), (6000~20000)MHz

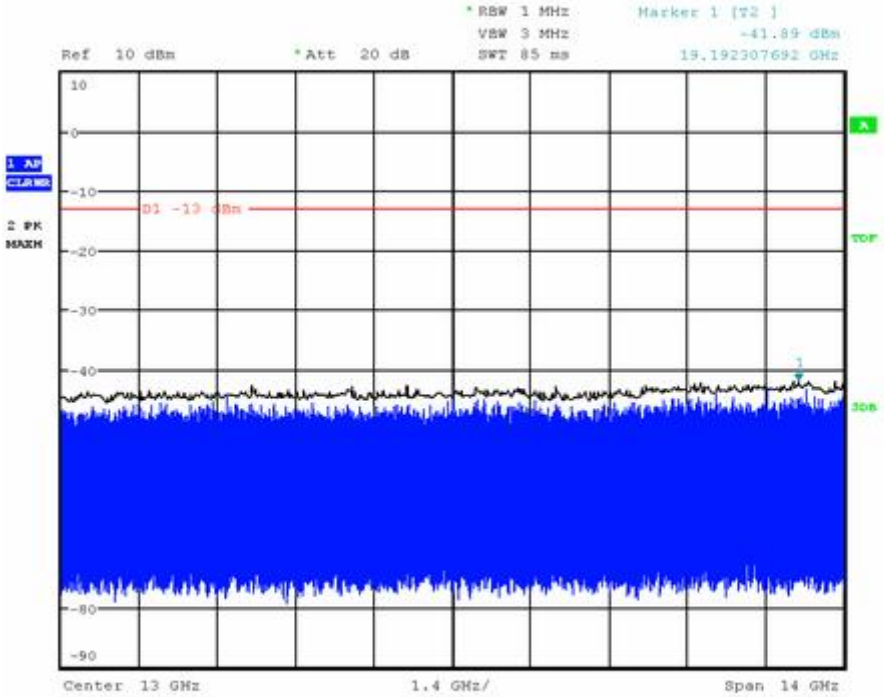

Date: 16.JUN.2011 10:14:59



检测结果/说明 (续页):

Results of test and additional explanation (continued page)

7.4.2 Test mode: GPRS 1900 (class 10, 2up, 3down)

1850.2MHz (channel 512), (20~30)MHz

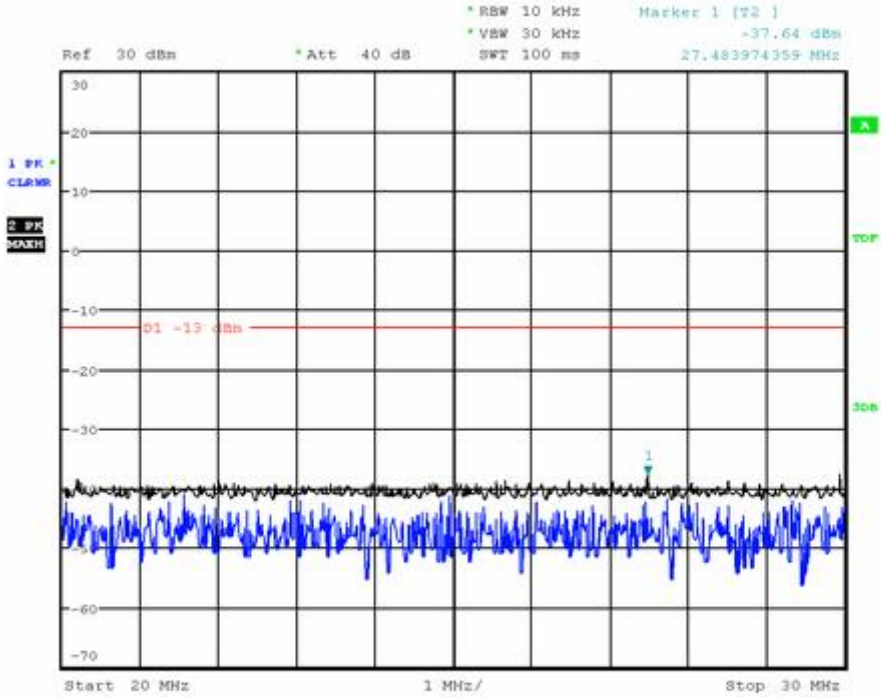

Date: 17.JUN.2011 09:24:09

检测结果/说明 (续页):

Results of test and additional explanation (continued page)

1850.2MHz (channel 512), (30~1000)MHz

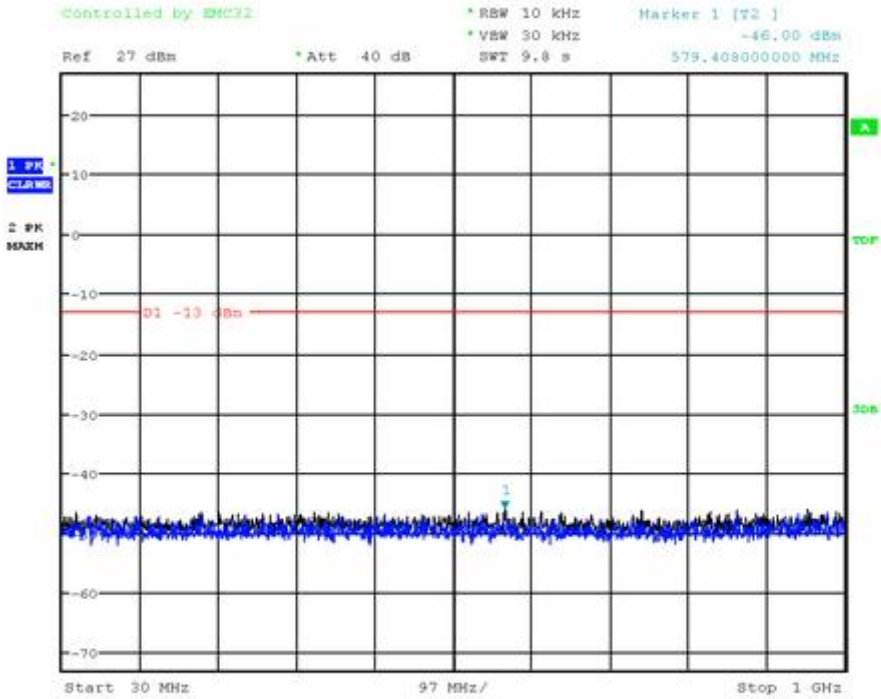

Date: 15.JUN.2011 10:47:59

检测结果/说明 (续页):

Results of test and additional explanation (continued page)

1850.2MHz (channel 512), (1000~6000)MHz

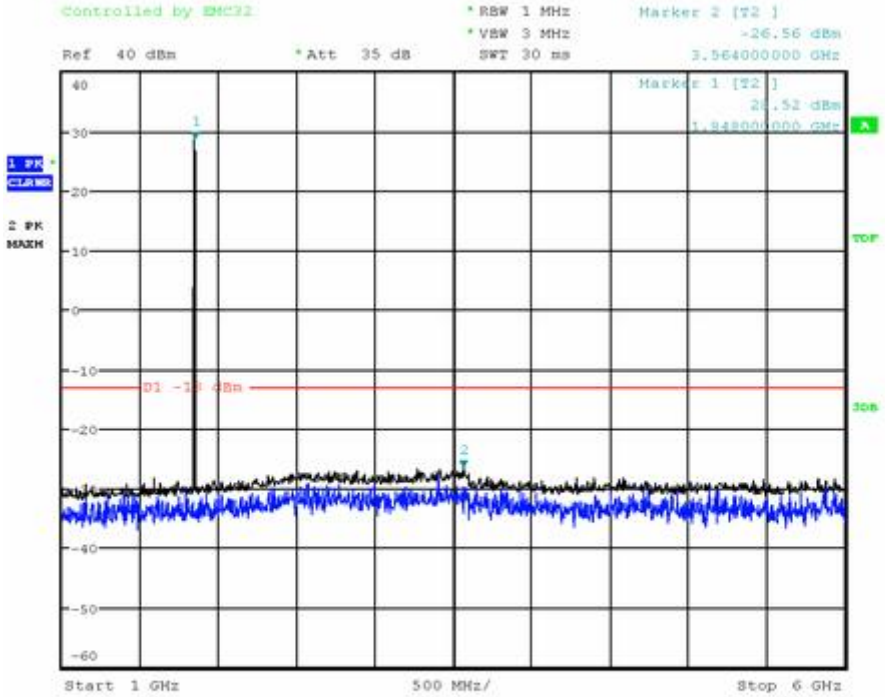

Date: 15.JUN.2011 10:44:38

Note: The signal beyond the limit is carrier

检测结果/说明 (续页):

Results of test and additional explanation (continued page)

1850.2MHz (channel 512), (6000~20000)MHz

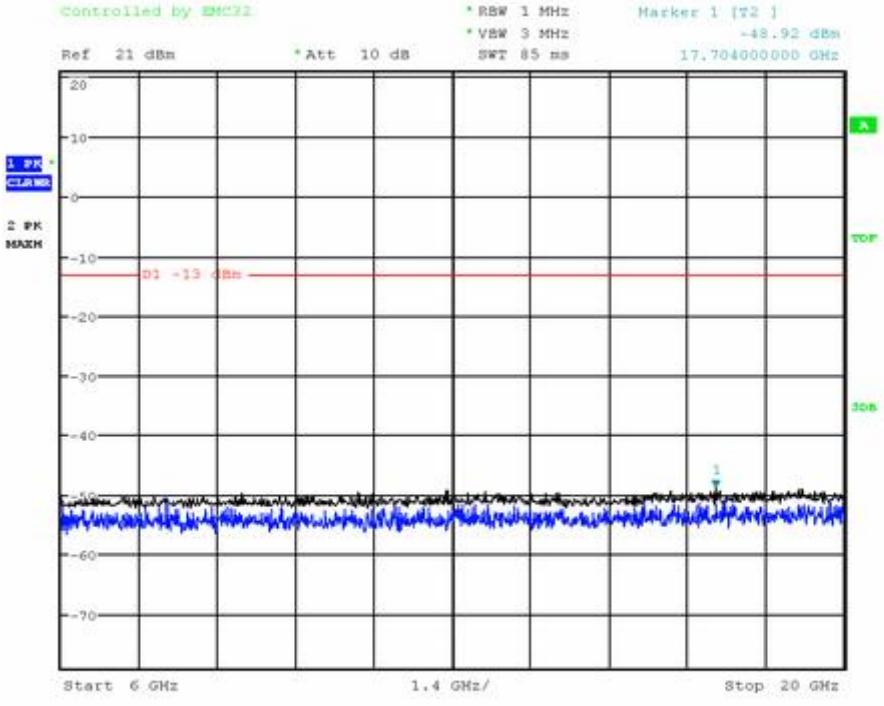

Date: 15.JUN.2011 10:34:31

检测结果/说明 (续页):

Results of test and additional explanation (continued page)

1880.0MHz (channel 661), (20~30)MHz

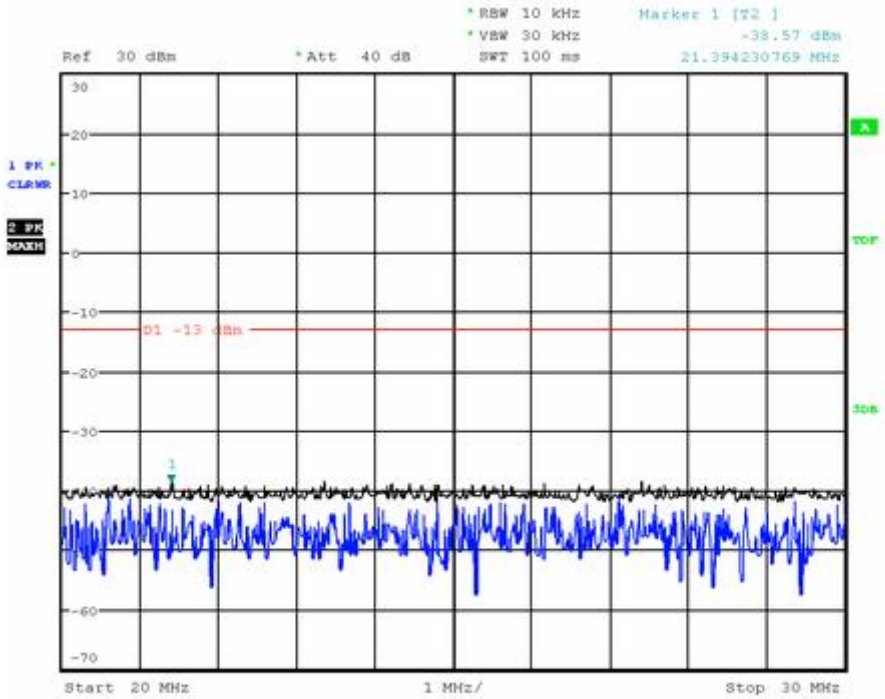

Date: 17 JUN 2011 09:25:38

检测结果/说明 (续页):

Results of test and additional explanation (continued page)

1880.0MHz (channel 661), (30~1000)MHz

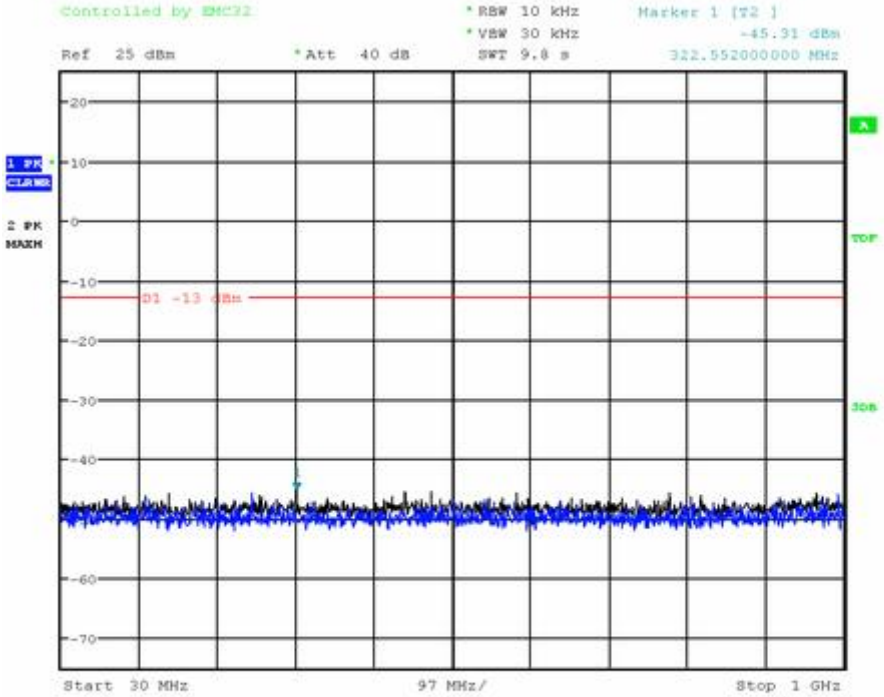

Date: 15.JUN.2011 10:50:06

检测结果/说明 (续页):

Results of test and additional explanation (continued page)

1880.0MHz (channel 661), 1000~6000MHz

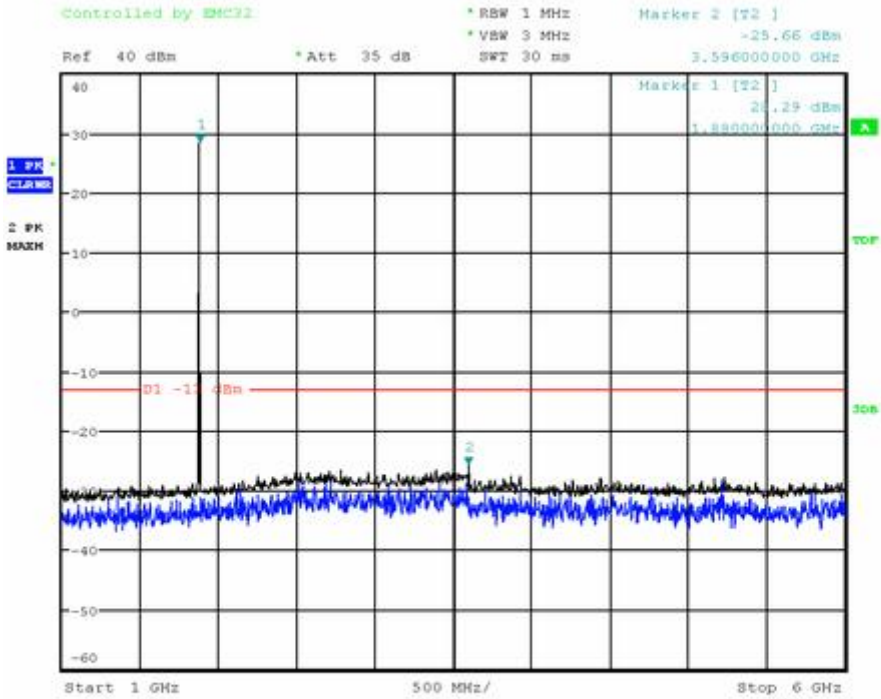

Date: 15.JUN.2011 10:43:35

Note: The signal beyond the limit is carrier

检测结果/说明 (续页):

Results of test and additional explanation (continued page)

1880.0MHz (channel 661), (6000~20000)MHz

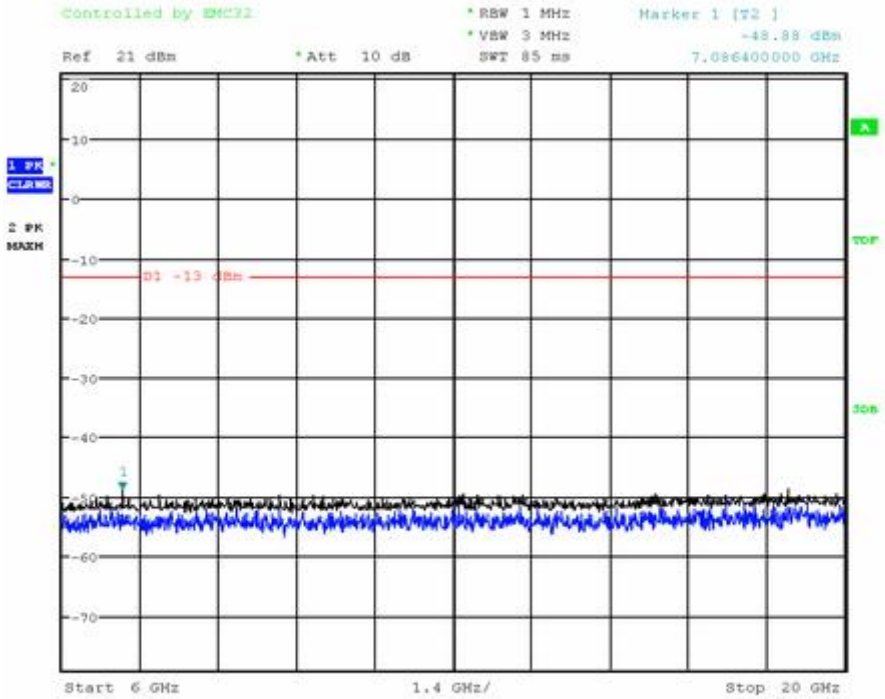

Date: 15.JUN.2011 10:35:36



检测结果/说明 (续页):

Results of test and additional explanation (continued page)

1909.8MHz (channel 810), (20~30)MHz

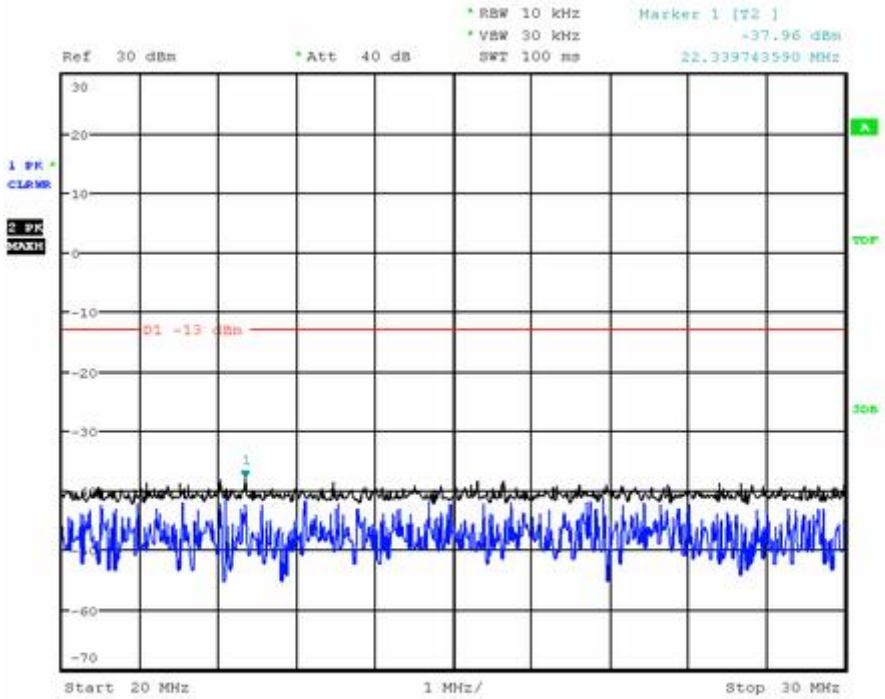

Date: 17 JUN 2011 09:26:46

检测结果/说明 (续页):

Results of test and additional explanation (continued page)

1909.8MHz (channel 810), (30~1000)MHz

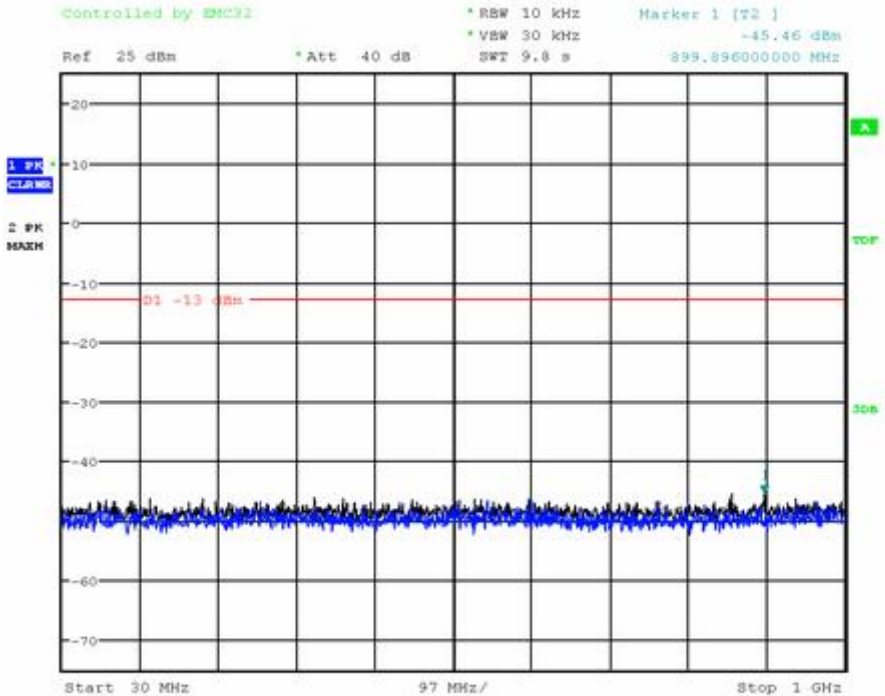

Date: 15.JUN.2011 10:51:51

检测结果/说明 (续页):

Results of test and additional explanation (continued page)

1909.8MHz (channel 810), (1000~6000)MHz

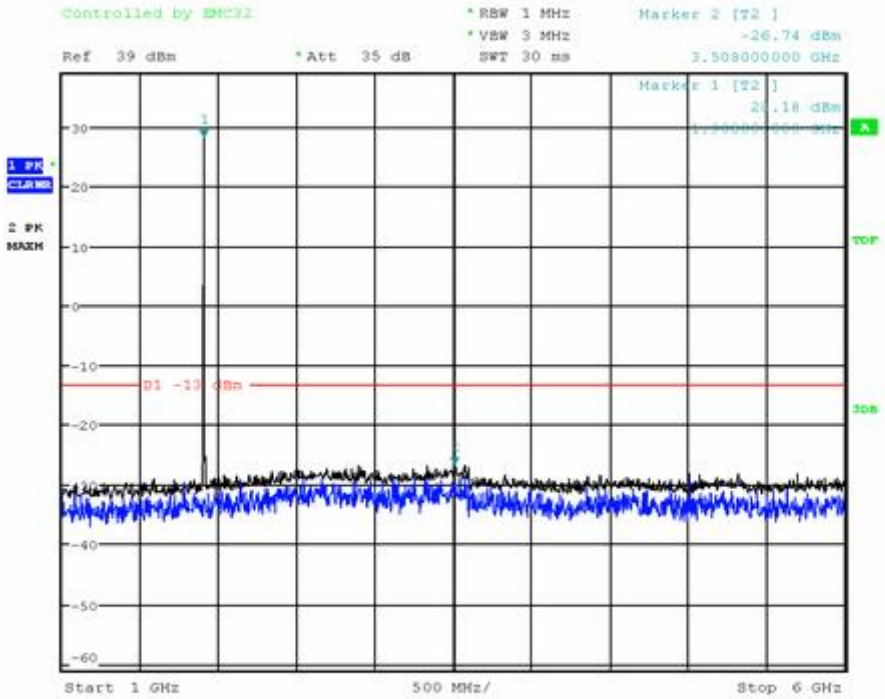

Date: 15.JUN.2011 10:42:27

Note: The signal beyond the limit is carrier

检测结果/说明 (续页):

Results of test and additional explanation (continued page)

1909.8MHz (channel 810), (6000~20000)MHz

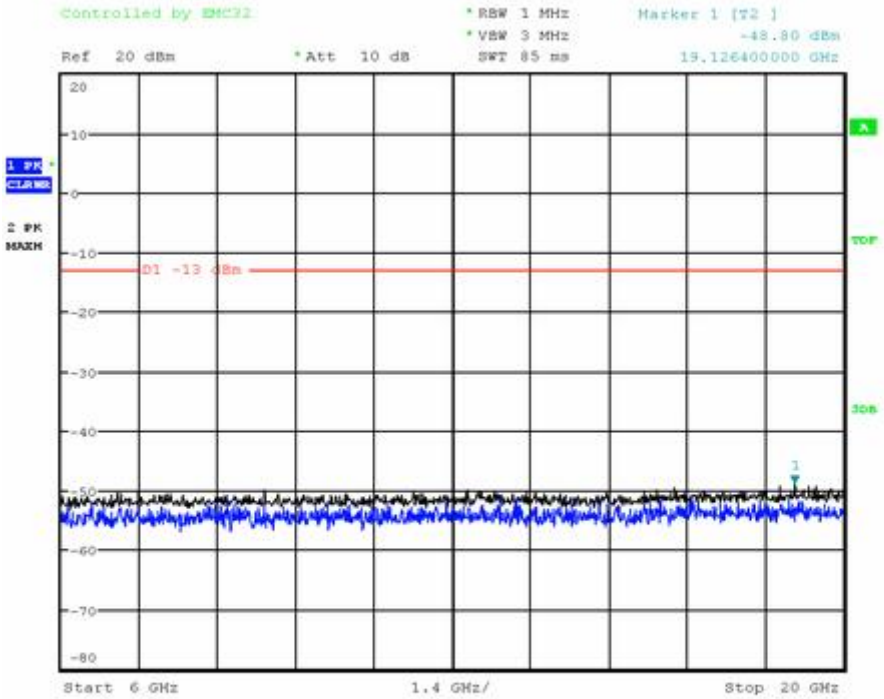

Date: 15.JUN.2011 10:36:32

检测结果/说明（续页）：

Results of test and additional explanation (continued page)

7.5 Test Instrumentation (Test date: 2011.06.15-2011.06.16)

Name/Model	Number	Due date
Universal Radio Communication Tester / CMU 200	容-026-01	2011.06.22
Spectrum Analyzer / FSU 26	容-026-45	2011.12.05
Power Splitter / 11667C	容-030-11	2011.07.21

7.6 Test Photograph

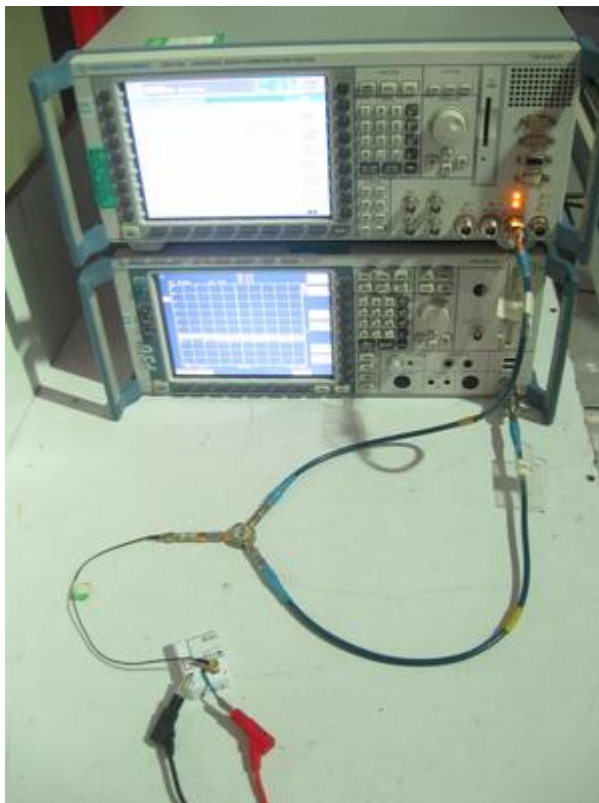

检测结果/说明（续页）：

Results of test and additional explanation (continued page)

## 8. Spurious Radiation Emission Test

### 8.1 Test setup

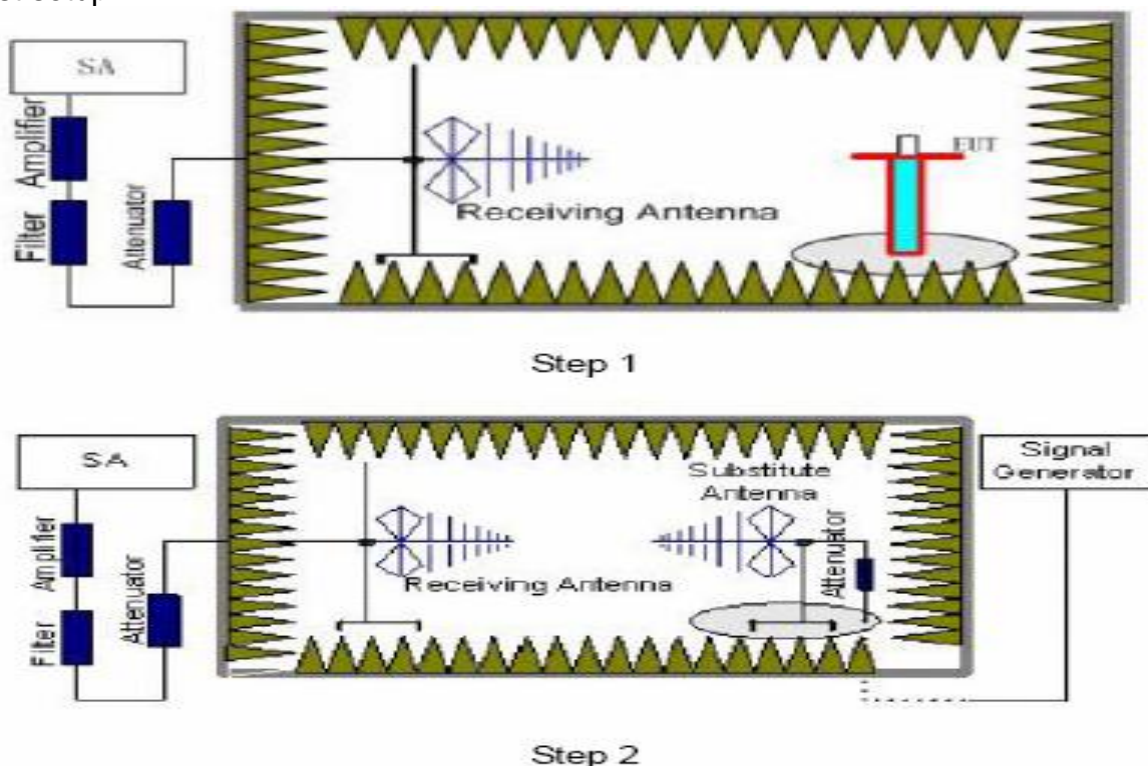

### 8.2 Limits

Limits	$<-13\text{dBm}$
--------	------------------

### 8.3 Test procedure

Test procedure:

Step 1:

EUT was placed on a 1.5 meter high non-conductive table at a 3 meter test distance from the test receive antenna. The height of receiving antenna is 1.5m. A radio link shall be established between EUT and Tester. The output power of the cell signal of the tester will be decreased until the output power of the EUT reaching a maximum value. The measurement is carried out using a spectrum analyzer or receiver. The spectrum analyzer scans from the lowest radio frequency signal generated in the equipment to 20GHz (higher than the 10<sup>th</sup> harmonic of the carrier). The peak detector is used and RBW is set to 1MHz for more than 1GHz and 10KHz for less than 1GHz on spectrum analyzer. Then the antenna height and turn table rotation is adjusted until the maximum power value is founded on spectrum analyzer or receiver. A notch filter is necessary in the band near to the carrier frequency. A high pass filter is needed to avoid the distortion of the testing equipment in the band above the carrier frequency.

检测结果/说明（续页）：

Results of test and additional explanation (continued page)

Step 2:

A log-periodic antenna or double-ridged waveguide horn antenna shall be substituted in place of the EUT. The log-periodic antenna will be driven by a signal generator and the level will be adjusted till the same power value on the spectrum analyzer or receiver. The level of the spurious emissions can be calculated through the level of the signal generator, cable loss, the gain of the substitution antenna and the reading of the spectrum analyzer or receiver.

Step 3:

Repeat step 1 and step 2 for receiving antenna the other polarization.

Step 4:

Repeat step 1, step 2 and step 3 for EUT the other two orientations.

8.4 Test results

Power source: DC 3.7V

8.4.1 Test mode: GPRS 850 (class 10, 2up, 3down)

Receiving antenna polarization	Frequency	Signal generator level	Cable loss	Gain	ERP	Limit	Result
	(MHz)	(dBm)	(dB)	(dBd)	(dBm)	(dBm)	
H	31.552	-46.70	0.47	-22.06	-69.23	-13	pass
	1674.100	-40.70	3.39	7.42	-36.67	-13	pass
	2867.800	-49.53	4.67	9.11	-45.09	-13	pass
	7326.300	-50.17	7.13	9.59	-47.71	-13	pass
	11621.700	-46.07	8.33	10.24	-44.16	-13	pass
	14583.000	-39.79	9.59	10.34	-39.04	-13	pass
V	34.268	-49.92	0.47	-20.22	-70.61	-13	pass
	152.802	-74.98	1.09	-5.56	-81.62	-13	pass
	1674.100	-41.78	3.39	7.42	-37.75	-13	pass
	2536.300	-49.52	4.63	8.52	-45.63	-13	pass
	7066.200	-49.84	7.15	9.72	-47.27	-13	pass
	14539.200	-40.72	9.55	10.32	-39.95	-13	pass

All configurations of EUT have been investigated and the worst case mode has been listed.

检测结果/说明（续页）：

Results of test and additional explanation (continued page)

8.4.2 Test mode: GPRS 1900 (class 10, 2up, 3down)

Receiving antenna polarization	Frequency	Signal generat or level	Cable loss	Gain	EIRP	Limit	Result
	(MHz)	(dBm)	(dB)	(dBi)	(dBm)	(dBm)	
H	32.037	-50.72	0.46	-19.58	-70.76	-13	pass
	745.957	-81.51	2.54	7.38	-76.67	-13	pass
	1314.400	-53.16	2.96	7.13	-48.99	-13	pass
	2157.600	-51.09	4.39	10.12	-45.36	-13	pass
	3700.200	-55.72	5.09	12.64	-48.17	-13	pass
	5550.900	-49.47	6.59	13.09	-42.97	-13	pass
	7400.400	-40.73	7.89	11.70	-36.92	-13	pass
	9250.500	-43.87	7.21	12.17	-38.91	-13	pass
	11101.200	-43.52	8.31	11.56	-40.27	-13	pass
V	32.037	-51.03	0.46	-19.58	-71.07	-13	pass
	1404.600	-53.27	3.30	7.34	-49.23	-13	pass
	1948.000	-52.39	3.98	9.98	-46.39	-13	pass
	3700.200	-55.36	5.09	12.64	-47.81	-13	pass
	5550.600	-49.88	6.59	13.09	-43.38	-13	pass
	7400.400	-41.06	7.89	11.70	-37.25	-13	pass
	9250.500	-45.54	7.21	12.17	-40.58	-13	pass
	11101.200	-43.22	8.31	11.56	-39.96	-13	pass
All configurations of EUT have been investigated and the worst case mode has been listed.							



检测结果/说明（续页）：

Results of test and additional explanation (continued page)

8.5 Test Instrumentation (Test date: 2011.06.08-2011.06.12)

Name/Model	Number	Due date
Microwave Signal Generator / SMR 20	容-001-02	2012.01.06
Ultra Broadband Antenna / HL 562	容-001-03	2012.06.13
Double-Ridged Waveguide Horn Antenna / HF 906	容-001-04	2012.06.16
VHA 9103 without telescopic rods for use with biconical broad-band elements BBA 9106 / BBA 9106 + VHA 9103	容-001-39	2012.06.13
Logarithmic Periodic Broadband Antenna / UHALP 9108 A	容-001-40	2012.06.13
Universal Radio Communication Tester / CMU 200	容-026-01	2011.06.22
Pre-Amplifier / AFS42-00101800	容-026-19	2012.01.19
Notch Filter / GSM 1900 UL	容-026-25	2011.06.17
Notch Filter / GSM 850	容-026-35	2011.06.17
Spectrum Analyzer / FSU 26	容-026-45	2011.12.05
Double-Ridged Waveguide Horn Antenna / 3115	容-030-03	2011.06.17

检测结果/说明（续页）：  
Results of test and additional explanation (continued page)

8.6 Test Photographs



检测结果/说明（续页）：  
Results of test and additional explanation (continued page)

X orientation



Y orientation



检测结果/说明（续页）：  
Results of test and additional explanation (continued page)

Z orientation



检测结果/说明（续页）：

Results of test and additional explanation (continued page)

## 9. Frequency Deviation Test

### 9.1 Test setup

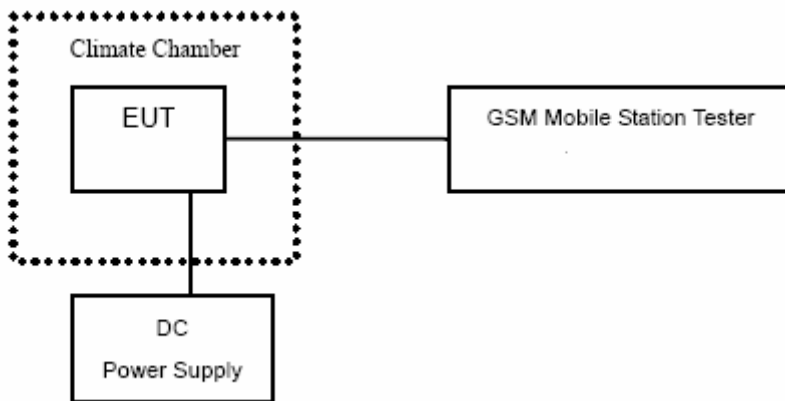

### 9.2 Limits

The carrier frequency of each transmitter in the Public Mobile Services must be maintained within the tolerances 2.5ppm.

### 9.3 Test procedure

#### Step 1: Frequency Stability vs. Temperature variations

The EUT and test equipment were set up as shown on the following section. With all power removed, the temperature was decreased to  $-30^{\circ}\text{C}$  and permitted to stabilize for three hours. Power was applied and the maximum change in frequency was note within one minute. With power OFF, the temperature was raised in  $10^{\circ}\text{C}$  steps. The sample was permitted to stabilize at each step for at least one-half hour. Power was applied and the maximum frequency change was noted within one minute. The temperature tests were performed for the worst case.

#### Step 2: Frequency Stability vs. voltage variations

The EUT was placed in a temperature chamber at  $25\pm 5^{\circ}\text{C}$  and connected as the following section. The power supply voltage to the EUT was varied from BEP to 115% of the nominal value measured at the input to the EUT. The variation in frequency was measured for the worst case.

检测结果/说明（续页）：

Results of test and additional explanation (continued page)

9.4 Test results

Test mode: GPRS 850 (class 10, 2up, 3down)			Power source: DC 3.7V	
Temperature (°C)	Voltage (V)	Reference frequency (MHz)	Test level (ppm)	Test results
-30	3.7	824.2 (channel 128)	$2.43 \times 10^{-2}$	Pass
	3.7	836.4 (channel 189)	$-2.15 \times 10^{-2}$	Pass
	3.7	848.8 (channel 251)	$-2.36 \times 10^{-2}$	Pass
-20	3.7	824.2 (channel 128)	$-2.43 \times 10^{-2}$	Pass
	3.7	836.4 (channel 189)	$-1.79 \times 10^{-2}$	Pass
	3.7	848.8 (channel 251)	$1.53 \times 10^{-2}$	Pass
-10	3.7	824.2 (channel 128)	$-2.55 \times 10^{-2}$	Pass
	3.7	836.4 (channel 189)	$-1.20 \times 10^{-2}$	Pass
	3.7	848.8 (channel 251)	$-1.65 \times 10^{-2}$	Pass
0	3.7	824.2 (channel 128)	$1.94 \times 10^{-2}$	Pass
	3.7	836.4 (channel 189)	$2.15 \times 10^{-2}$	Pass
	3.7	848.8 (channel 251)	$2.00 \times 10^{-2}$	Pass
10	3.7	824.2 (channel 128)	$-1.58 \times 10^{-2}$	Pass
	3.7	836.4 (channel 189)	$-1.67 \times 10^{-2}$	Pass
	3.7	848.8 (channel 251)	$-2.24 \times 10^{-2}$	Pass
20	3.7	824.2 (channel 128)	$-2.31 \times 10^{-2}$	Pass
	3.7	836.4 (channel 189)	$-1.32 \times 10^{-2}$	Pass
	3.7	848.8 (channel 251)	$-1.77 \times 10^{-2}$	Pass
30	3.7	824.2 (channel 128)	$-2.18 \times 10^{-2}$	Pass
	3.7	836.4 (channel 189)	$-2.39 \times 10^{-2}$	Pass
	3.7	848.8 (channel 251)	$-2.24 \times 10^{-2}$	Pass
40	3.7	824.2 (channel 128)	$-2.18 \times 10^{-2}$	Pass
	3.7	836.4 (channel 189)	$-2.03 \times 10^{-2}$	Pass
	3.7	848.8 (channel 251)	$-2.00 \times 10^{-2}$	Pass
50	3.7	824.2 (channel 128)	$-1.70 \times 10^{-2}$	Pass
	3.7	836.4 (channel 189)	$-1.79 \times 10^{-2}$	Pass
	3.7	848.8 (channel 251)	$-2.00 \times 10^{-2}$	Pass
21	3.5	824.2 (channel 128)	$1.94 \times 10^{-2}$	Pass
	3.5	836.4 (channel 189)	$1.79 \times 10^{-2}$	Pass
	3.5	848.8 (channel 251)	$1.65 \times 10^{-2}$	Pass
21	4.2	824.2 (channel 128)	$2.18 \times 10^{-2}$	Pass
	4.2	836.4 (channel 189)	$2.03 \times 10^{-2}$	Pass
	4.2	848.8 (channel 251)	$1.30 \times 10^{-2}$	Pass

检测结果/说明（续页）：

Results of test and additional explanation (continued page)

Test mode: GPRS 1900 (class 10, 2up, 3down)			Power source: DC 3.7V	
Temperature (°C)	Voltage (V)	Reference frequency (MHz)	Test level (ppm)	Test results
-30	3.7	1850.2 (channel 512)	$-1.35 \times 10^{-2}$	Pass
	3.7	1880.0 (channel 661)	$-1.76 \times 10^{-2}$	Pass
	3.7	1909.8 (channel 810)	$-1.62 \times 10^{-2}$	Pass
-20	3.7	1850.2 (channel 512)	$1.78 \times 10^{-2}$	Pass
	3.7	1880.0 (channel 661)	$1.70 \times 10^{-2}$	Pass
	3.7	1909.8 (channel 810)	$1.41 \times 10^{-2}$	Pass
-10	3.7	1850.2 (channel 512)	$-1.89 \times 10^{-2}$	Pass
	3.7	1880.0 (channel 661)	$-1.70 \times 10^{-2}$	Pass
	3.7	1909.8 (channel 810)	$-1.73 \times 10^{-2}$	Pass
0	3.7	1850.2 (channel 512)	$-1.08 \times 10^{-2}$	Pass
	3.7	1880.0 (channel 661)	$1.17 \times 10^{-2}$	Pass
	3.7	1909.8 (channel 810)	$1.62 \times 10^{-2}$	Pass
10	3.7	1850.2 (channel 512)	$1.68 \times 10^{-2}$	Pass
	3.7	1880.0 (channel 661)	$1.70 \times 10^{-2}$	Pass
	3.7	1909.8 (channel 810)	$1.47 \times 10^{-2}$	Pass
20	3.7	1850.2 (channel 512)	$-1.68 \times 10^{-2}$	Pass
	3.7	1880.0 (channel 661)	$-1.76 \times 10^{-2}$	Pass
	3.7	1909.8 (channel 810)	$-1.73 \times 10^{-2}$	Pass
30	3.7	1850.2 (channel 512)	$-1.84 \times 10^{-2}$	Pass
	3.7	1880.0 (channel 661)	$-1.70 \times 10^{-2}$	Pass
	3.7	1909.8 (channel 810)	$-1.47 \times 10^{-2}$	Pass
40	3.7	1850.2 (channel 512)	$-1.35 \times 10^{-2}$	Pass
	3.7	1880.0 (channel 661)	$-1.28 \times 10^{-2}$	Pass
	3.7	1909.8 (channel 810)	$-1.57 \times 10^{-2}$	Pass
50	3.7	1850.2 (channel 512)	$-1.68 \times 10^{-2}$	Pass
	3.7	1880.0 (channel 661)	$-1.28 \times 10^{-2}$	Pass
	3.7	1909.8 (channel 810)	$1.36 \times 10^{-2}$	Pass
21	3.5	1850.2 (channel 512)	$1.14 \times 10^{-2}$	Pass
	3.5	1880.0 (channel 661)	$1.33 \times 10^{-2}$	Pass
	3.5	1909.8 (channel 810)	$1.62 \times 10^{-2}$	Pass
21	4.2	1850.2 (channel 512)	$8.65 \times 10^{-3}$	Pass
	4.2	1880.0 (channel 661)	$1.12 \times 10^{-2}$	Pass
	4.2	1909.8 (channel 810)	$1.05 \times 10^{-2}$	Pass

检测结果/说明（续页）：

Results of test and additional explanation (continued page)

9.5 Test Instrumentation (Test date: 2011.06.09-2011.06.21)

Name/Model	Number	Due date
Cold-heat climate test chamber / GDW-60B	容-011-44	2012.01.03
Universal Radio Communication Tester / CMU 200	容-026-01	2011.06.22
Power Splitter / 11667C	容-030-11	2011.07.21
Power Splitter / 11667C	容-030-11	2011.07.21

9.6 Test Photographs





检测结果/说明（续页）：  
Results of test and additional explanation (continued page)

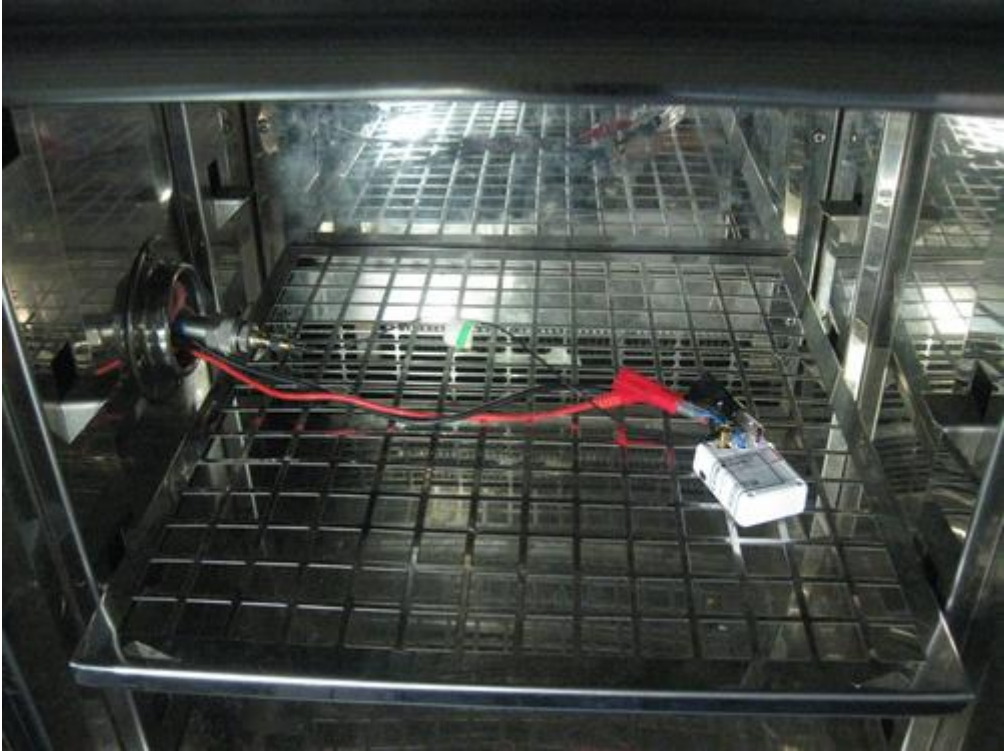

检测结果/说明 (续页):

Results of test and additional explanation (continued page)

Attachment 1: Main measuring instruments used in this test

本次检测所使用的主要测量仪器:

Main measuring instruments used in this test

名称/型号 Name/Model	编号 Number	证书编号/有效期限 Certificate No./Due date	测量范围/准确度 Measuring range/accuracy
Microwave Signal Generator / SMR 20	容-001-02	2011F33-10-000107 / 2012.01.06	10 MHz ~ 20 GHz, Frequency Resolution 1kHz, 1GHz~18 GHz:> 10dBm, 18GHz~20GHz:> 8dBm
Ultra Broadband Antenna / HL 562	容-001-03	XDdj2011-9133 / 2012.06.13	30 MHz ~ 3000 MHz, Cross Polarisation Suppression > 20dB, Input Impedance: 50 Ω, VSWR typ. < 2, GAIN: 8dBi / Gain: 8dBi (typ.) from 200 MHz
Double-Ridged Waveguide Horn Antenna / HF 906	容-001-04	XDdj2011-9134 / 2012.06.16	1 GHz ~ 18 GHz, Nominal Impedance: 50 Ω, VSWR < 1.5, Gain : 7dB (typ.) ~ 14 dB (typ.) / Gain: 7dB typ ~ 14dB typ.
Broad-band Horn Antenna / BBHA 9120D	容-001-06	XDdj2010-1298 / 2011.06.17	1 GHz ~ 18 GHz, GAIN : 6 dBi ~ 18 dBi, Antenna Factor: 24dB/m ~ 42dB/m / f < 10GHz: ± 1.5 dB, 10GHz ~ 20GHz: ± 2.0 dB
Spectrum Analyzer / FSU 26	容-001-33	2010F33-10-001506 / 2011.06.24	20 Hz ~ 26.5 GHz, 1dB compression point (0 dB RF attenuation): +13 dBm; Displayed average noise level with preamplifier ON, 1GHz, 10Hz RBW: < -152 dBm / Total measurement error, f < 3.6 GHz: 0.3 dB
VHA 9103 without telescopic rods for use with biconical broad-band elements BBA 9106 / BBA 9106 + VHA 9103	容-001-39	XDdj2011-9138 / 2012.06.13	25MHz ~ 300 MHz; max. power 15W (30W short-time); Element extension range: 0.485m ~ 4.85 m balun; reflon coax/ferrite 1:1 (50Ω); Antenna factors (50Ω): -1.9dB/m ~ 18.3 dB/m; Antenna Gain over Isotropic: ca. +1dBi
Logarithmic Periodic Broadband Antenna / UHALP 9108 A	容-001-40	XDdj2011-9139 / 2012.06.13	250 MHz ~ 2.4 GHz; 1kW

检测结果/说明（续页）：

Results of test and additional explanation (continued page)

名称/型号 Name/Model	编号 Number	证书编号/有效期限 Certificate No./Due date	测量范围/准确度 Measuring range/accuracy
Cold-heat climate test chamber / GDW-60B	容-011-44	2010G40-10-400026 / 2012.01.03	Temperature Adjustment Range: -60 degree ~ +130 degree; Power Source: AC 380V, Total Power: 5.5 kW; Temperature Fluctuation: $\pm 0.5$ degree; Average Temperature Drop/Increase Rate: 0.7 degree ~ 1.0 degree/min, Temperature Deviation: $\leq \pm 2$ degree, Time Adjustment Range: 0 ~ 9999/H, Dimension: 400*400*375mm
Universal Radio Communication Tester / CMU 200	容-026-01	2010F44-10-000433 / 2011.06.22	100 kHz ~ 2700 MHz, Frequency resolution: 0.1 Hz
Pre-Amplifier / AFS42-00101800	容-026-19	2011J10-10-901009 / 2012.01.19	1 GHz ~ 18 GHz, 35 dB Gain, N.F.: 2.5 dB
Notch Filter / GSM 1900 UL	容-026-25	2010F11-10-005101 / 2011.06.17	Notch Filter for GSM 1900 UL
Notch Filter / GSM 850	容-026-35	2010F11-10-005096 / 2011.06.17	Notch Filter for GSM 850
Spectrum Analyzer / FSU 26	容-026-45	2010F33-10-002620 / 2011.12.05	20 Hz ~ 26.5 GHz; Displayed average noise level with preamplifier ON, 1GHz, 10Hz RBW: $< -152$ dBm / Total measurement error, $f < 3.6$ GHz: 0.3 dB
Universal Radio Communication Tester / CMU 200	容-026-48	2010F44-10-000856 / 2011.11.23	100 kHz ~ 2700 MHz, Frequency resolution: 0.1 Hz
Double-Ridged Waveguide Horn Antenna / 3115	容-030-03	XDdj2010-1291 / 2011.06.17	750 MHz ~ 18 GHz, VSWR Ratio (AVG) $< 1.5$ : 1, Max. Continuous Power: 300W, Peak Power: 500W, Front to Back Ratio: 20dB, Cross Polarization: 20 dB minimum
Power Splitter / 11667C	容-030-11	2010J10-10-907001 / 2011.07.21	DC ~ 50 GHz, Maximum input power: + 27 dBm, 0.5W MAX. Input Return Loss (SWR) : 12 dB (1.65), Equivalent Output SWR: 1.65, Output Tracking: 0.40 dB

检测结果/说明（续页）：  
Results of test and additional explanation (continued page)

Attachment 2: EUT photographs



adapter



检测结果/说明（续页）：

Results of test and additional explanation (continued page)

battery + board

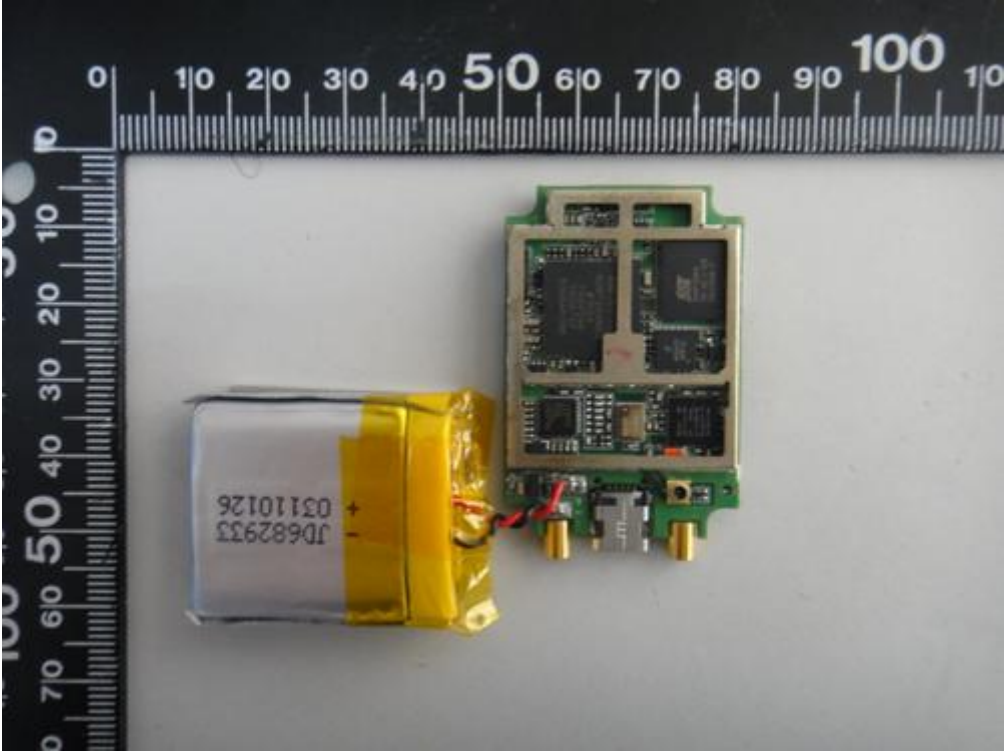

board

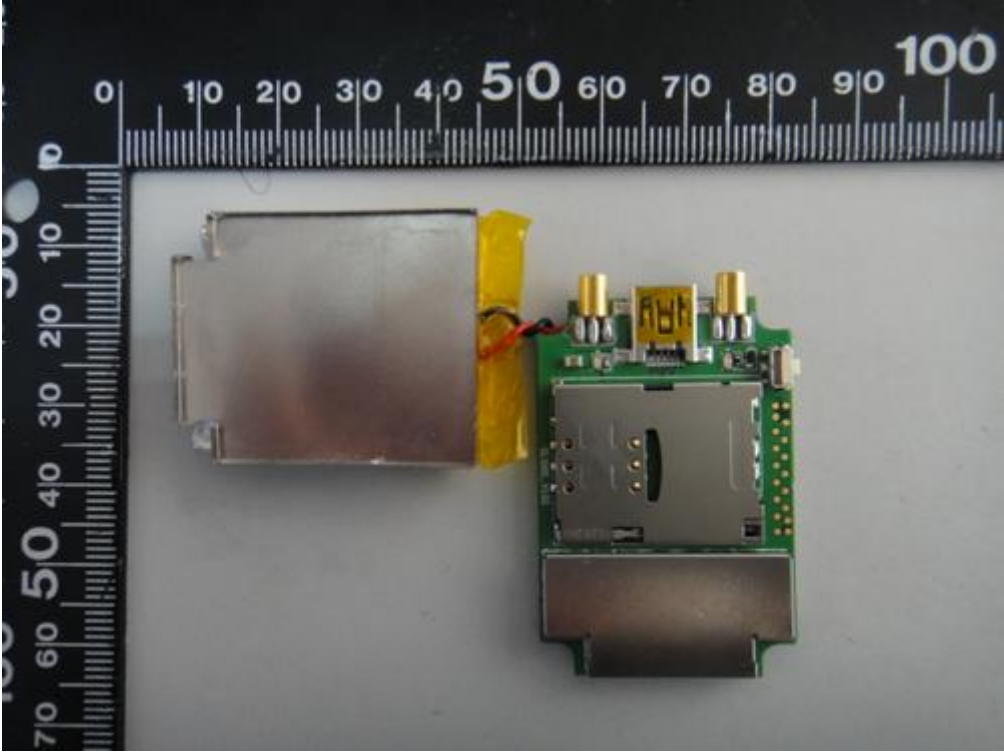

检测结果/说明（续页）：  
Results of test and additional explanation (continued page)

enclosure



usb cable



End