



Test Report

Product Name : GPS Locator
Model No. : CP100
FCC ID. : YQD-CP100

Applicant : Quealink Wireless Solutions Co., Ltd
Address : Room 501, Building 9, No.99 TianZhou Road, Shanghai,
China

Date of Receipt : 2011/03/11
Date of Test : 2011/03/11-2011/05/16
Report No. : 201110-3-03006F

The test results relate only to the samples tested.

The test report shall not be reproduced except in full without the written approval of SIMT EMC Lab.

This report must not be used to claim product endorsement by NVLAP any agency of the U.S. Government

Test Report Certification

Test Date: 2011/03/11-2011/05/16

Report No. : 201110-3-03006F

SIMT EMC Lab

Product Name : GPS Locator
 Applicant : Queclink Wireless Solutions Co., Ltd
 Address : Room 501, Building 9, No.99 TianZhou Road, Shanghai, China
 Manufacturer : Queclink Wireless Solutions Co., Ltd
 Address : Room 501, Building 9, No.99 TianZhou Road, Shanghai, China
 Model No. : CP100
 FCC ID. : YQD-CP100
 Rated Voltage : Battery (3.4~4.2)V, Adapter(230V/50Hz)
 Trade Name : Queclink
 Measurement Standard : FCC CFR Title 47 Part 15.247, ANSI C 63.4:2003,RSS 210:2007
 Date of Receipt: : 2011/03/11
 Date of Test : 2011/03/11-2011/05/16
 Date of report : 2011/05/16
 Test Result : Complied

The test results relate only to the samples tested.

The test report shall not be reproduced except in full without the written approval of SIMT EMC Lab.

This report must not be used to claim product endorsement by NVLAP any agency of the U.S. Government

Documented By

Zhou Haibei

(Zhou Haibei)



Tested By

Liu Qi

(Liu Qi)

Approved By

Wang Hui

(Wang Hui)

TABLE OF CONTENTS

Description	Page
1. General Information.....	5
1.1. EUT Description	5
1.2. Test Mode.....	5
1.3. Tested System Details	6
1.4. Configuration of tested System.....	6
1.5. EUT Exercise Software	7
1.6. Test Facility	8
2. Test Summary	9
3. Power spectral density.....	10
3.1. Test Equipment	10
3.2. Test Setup	10
3.3. Limits.....	10
3.4. Test Procedure	11
3.5. Test Specification	11
3.6. EUT Operation	11
3.7. Test Result	11
4. 6 dB bandwidth.....	21
4.1. Test Equipment	21
4.2. Test Setup	21
4.3. Limits.....	21
4.4. Test Procedure	22
4.5. Test Specification	22
4.6. EUT Operation	22
4.7. Test Result	23
5. Peak Output Power (Conduction).....	33
5.1. Test Equipment	33
5.2. Test Setup	33
5.3. Limits.....	33
5.4. Test Procedure	33
5.5. Test Specification	34
5.6. EUT Operation	34
5.7. Test Result	34
6. Spurious Emissions (Conduction)	44
6.1. Test Equipment	44
6.2. Test Setup	44
6.3. Limits.....	44
6.4. Test Procedure	45
6.5. Test Specification	45
6.6. EUT Operation	45

6.7.	Test Result	46
7.	Band edge measurement	63
7.1.	Test Equipment	63
7.2.	Test Setup	63
7.3.	Limits	63
7.4.	Test Procedure	64
7.5.	Test Specification	64
7.6.	EUT Operation	64
7.7.	Test Result	64
8.	Spurious Emissions (Radiation).....	71
8.1.	Test Equipment	71
8.2.	Test Setup	71
8.3.	Limits	72
8.4.	Test Procedure	72
8.5.	Test Specification	73
8.6.	EUT Operation	74
8.7.	Test Result	74
9.	Test Setup Photo	77
9.1.	Radiation Emission Setup Photo	77
9.2.	RF conducted Test Setup Photo	79
9.3.	EUT Axis of Setup Photo	80
10.	Internal Photo	82

Reference: Laboratory of License

1. General Information

1.1. EUT Description

Product Name	GPS Locator
Trade Name	Queclink
Model No.	CP100
Type of modulation	Wifi: 64QAM (54.48Mbps), 16QAM (36, 24Mbps), QPSK (18, 12Mbps), BPSK (9, 6Mbps); CCK (11, 5.5Mbps), DQPSK (2Mbps), DBPSK (1Mbps)
Type of antenna joint	Spring touch
Antenna type	Soldered on PCB
Tx Frequency Range	Wifi: 2412MHz~2462MHz
Antenna Gain	Wifi: -1.5dBi
Channel number	Wifi: 11
Channel separation	Wifi: 5MHz (ch1~ch11)
Rx Frequency Range	Wifi: 2412MHz~2462MHz

1.2. Test Mode

SIMT EMC has verified the construction and function in typical operation. All the test modes were carried out with the EUT in normal operation, which was shown in this test report and defined as:

Test Mode	Wifi (keep continuous transmitting)
-----------	-------------------------------------

1.3. Tested System Details

The types for all equipments, plus descriptions of all cables used in the tested system (including inserted cards) are:

Product	Manufacturer	Model No.	Serial No.	Power Cord	
1	EUT	Quealink Wireless Solutions Co., Ltd	CP100	N/A	Non-Shielded, 1.00m
2	PC	Lenovo	14002	EB09094065	N/A
3	Adapter	Soucething High Electric (iamen) Co., Ltd	P-05113-050050	N/A	Shielded, 1.19m

1.4. Configuration of tested System

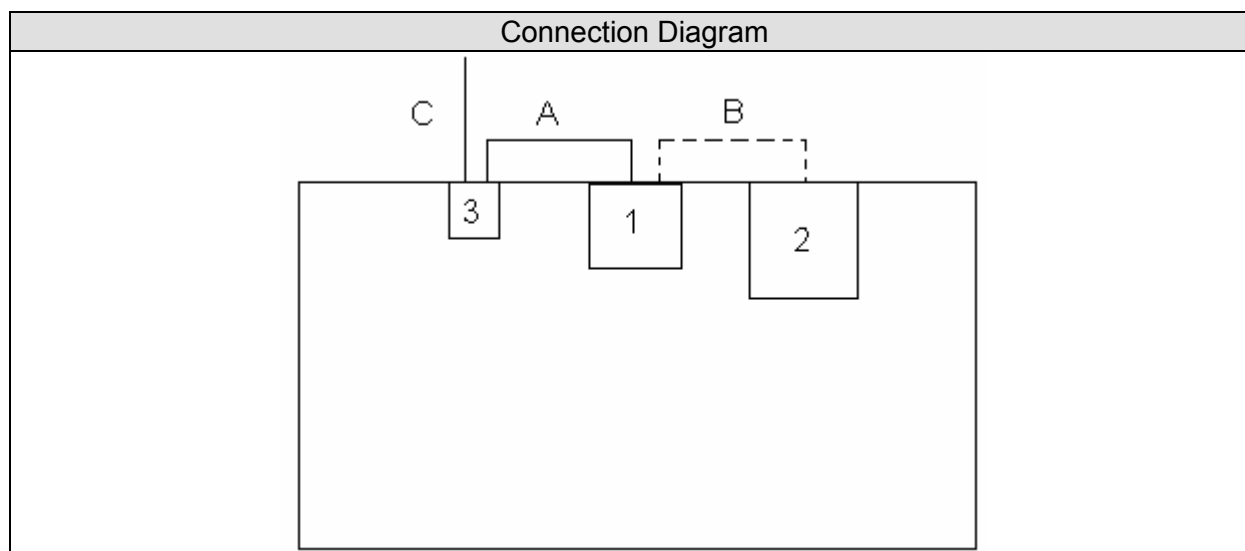

Signal Cable Type	Signal cable Description	
A	Output cable on adapter	1-(Shielded, 1.19m)
B	USB cable	1-(Shielded, 1.04m)
C	Input cable on adapter	N/A

1.5. EUT Exercise Software

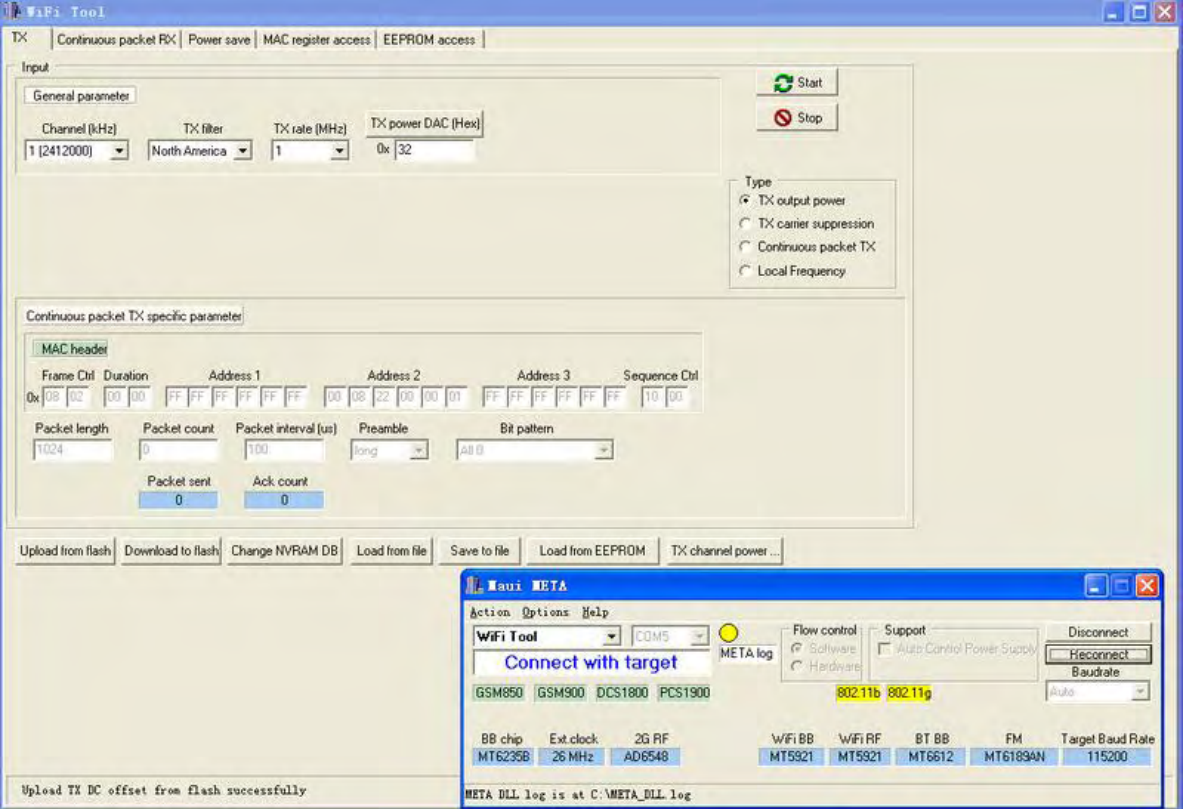
1	Power on the EUT.
2	<p>The engineering mode is used to set the TX channel, rate and power level by the software Maui META. The detailed setup was displayed as follow.</p>  <p>The screenshot displays two software windows. The top window is 'WiFi Tool' with tabs for 'Continuous packet RX', 'Power save', 'MAC register access', and 'EEPROM access'. It features an 'Input' section with 'General parameter' (Channel: 1 [2412000], TX filter: North America, TX rate: 1, TX power DAC: 0x32) and 'Continuous packet TX specific parameter' (MAC header, Packet length: 1024, Packet count: 0, Packet interval: 100, Preamble: long, Bit pattern: All 0). The bottom window is 'Maui META' showing 'Connect with target' for 'WiFi Tool' on 'COM5'. It lists various protocols (GSM850, GSM900, DCS1800, PCS1900) and hardware details (BB chip: MT6235B, Ext clock: 26 MHz, 2G RF: AD6548, WiFi BB: MT5921, WiFi RF: MT5921, BT BB: MT6612, FM: MT61894N, Target Baud Rate: 115200). A status bar at the bottom indicates 'Upload TX DC offset from flash successfully' and 'META DLL log is at C:\META_DLL.log'.</p>
3	Perform test .

1.6. Test Facility

Site Description:

Jan 01, 2011 Accreditation on NVLAP
NVLAP Lab Code: 200632-0

June 26, 2010 Accreditation on DNV
Statement No.: 639-10-LAB22

Site Name: SIMT EMC Lab



Site Address: 716 Yi Shan Road. Shanghai. China
TEL: 8621-6470-1390 / FAX : 8621-6451-4252
E-Mail: EMC@SIMT.com.cn

2. Test Summary

FCC Rule	DESCRIPTION OF TEST	Result	Section
§15.247(e)	Power spectral density	Passed	3
§15.247 (a)	6 dB bandwidth	Passed	4
§15.247(b)	Peak Output Power (Conduction)	Passed	5
§15.247(d)	Spurious Emissions (Conduction)	Passed	6
§15.247(d)	Band edge measurement	Passed	7
§15.247(d) §15.35(b) §15.209(a)	Spurious Emissions (Radiation)	Passed	8

3. Power spectral density

3.1. Test Equipment

The following test equipment are used during the Power spectral density test:

Item	Instrument	Manufacturer	Type No./Serial No	Due Date
1	Spectrum Analyzer	R & S	FSU 26/ 200932	2011.12.05
2	10dB Attenuator	Agilent	8493C/ 76156	2011.12.19

3.2. Test Setup

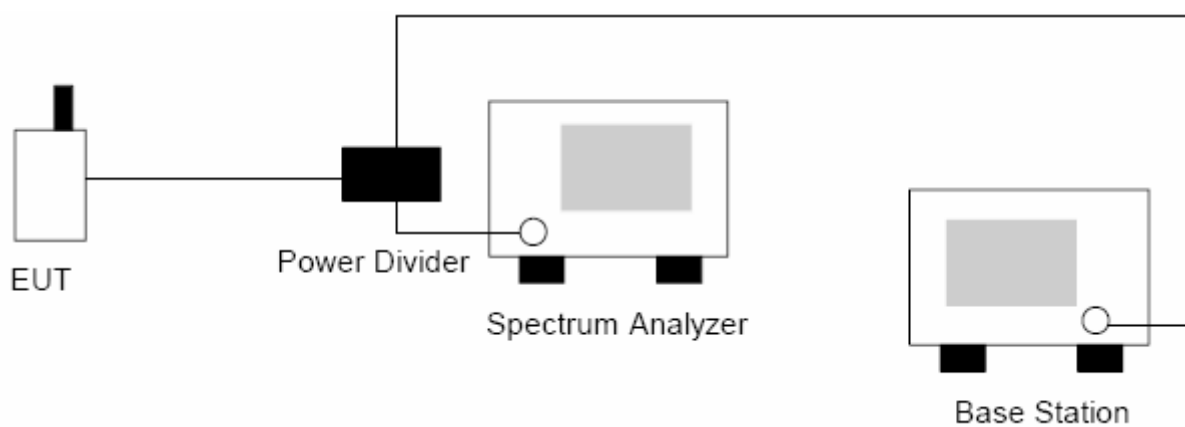

3.3. Limits

Limits	≤8dBm
--------	-------

3.4. Test Procedure

Use the following spectrum analyzer settings:

Span = 1.5MHz

RBW \geq 3KHz

VBW \geq RBW

Sweep time=span/ RBW

Detector function = peak

Trace = max hold

Allow the trace to stabilize.

3.5. Test Specification

According to CFR 47 FCC Part 15.247

3.6. EUT Operation

See chapter 1.2 of this test report.

3.7. Test Result

channel	mode	Data Rate (Mbps)	Measured level (dBm)	Limit (dBm)	Result
1	802.11b	1	-1.04	\leq 8.00	Pass
		5.5	0.13	\leq 8.00	Pass
		11	-0.59	\leq 8.00	pass
	802.11g	6	-13.28	\leq 8.00	Pass
		24	-11.17	\leq 8.00	Pass
		54	-13.00	\leq 8.00	pass
6	802.11b	1	6.30	\leq 8.00	Pass
		5.5	3.01	\leq 8.00	Pass
		11	5.42	\leq 8.00	pass
	802.11g	6	-11.43	\leq 8.00	Pass
		24	-12.70	\leq 8.00	Pass
		54	-13.33	\leq 8.00	pass
11	802.11b	1	5.29	\leq 8.00	Pass
		5.5	7.53	\leq 8.00	Pass
		11	7.36	\leq 8.00	pass
	802.11g	6	-11.60	\leq 8.00	Pass
		24	-12.79	\leq 8.00	Pass
		54	-14.03	\leq 8.00	pass

802.11b, channel 1, 1Mbps

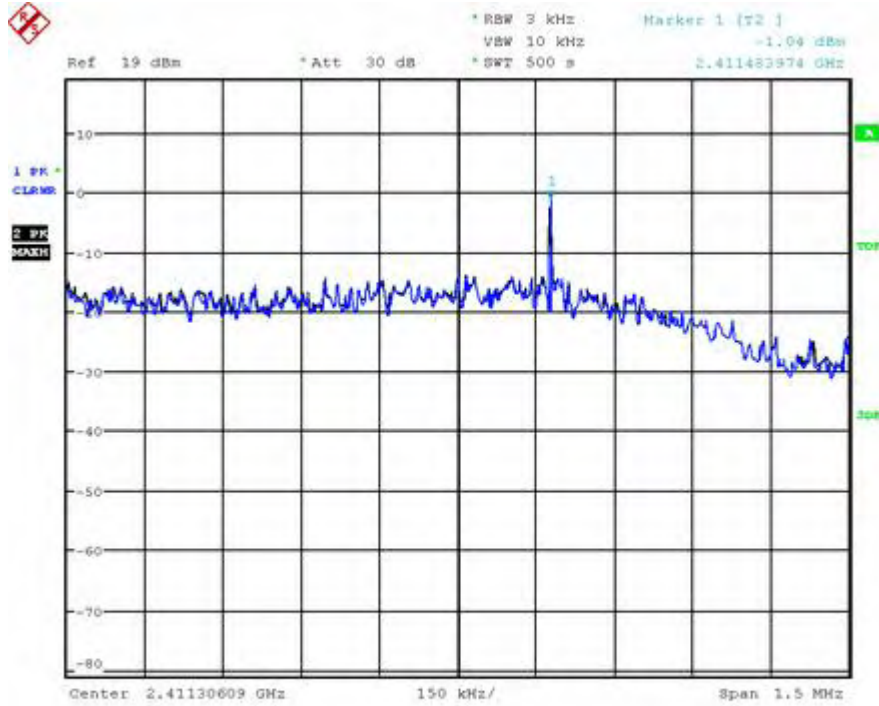

Date: 31.MAR.2011 06:59:26

802.11b, channel 1, 5.5Mbps

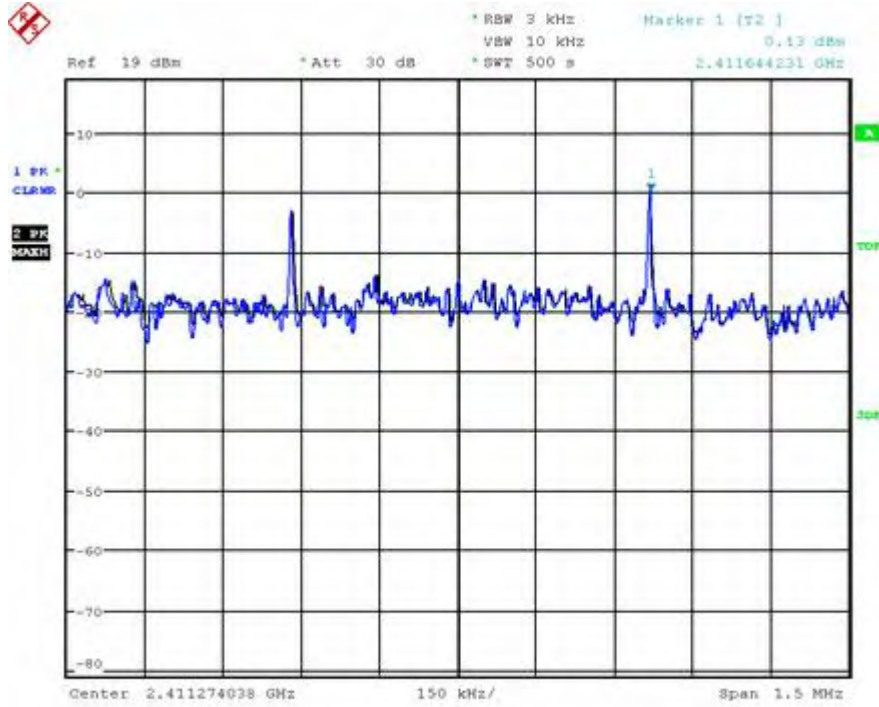

Date: 31.MAR.2011 07:35:25

802.11b, channel 1, 11Mbps

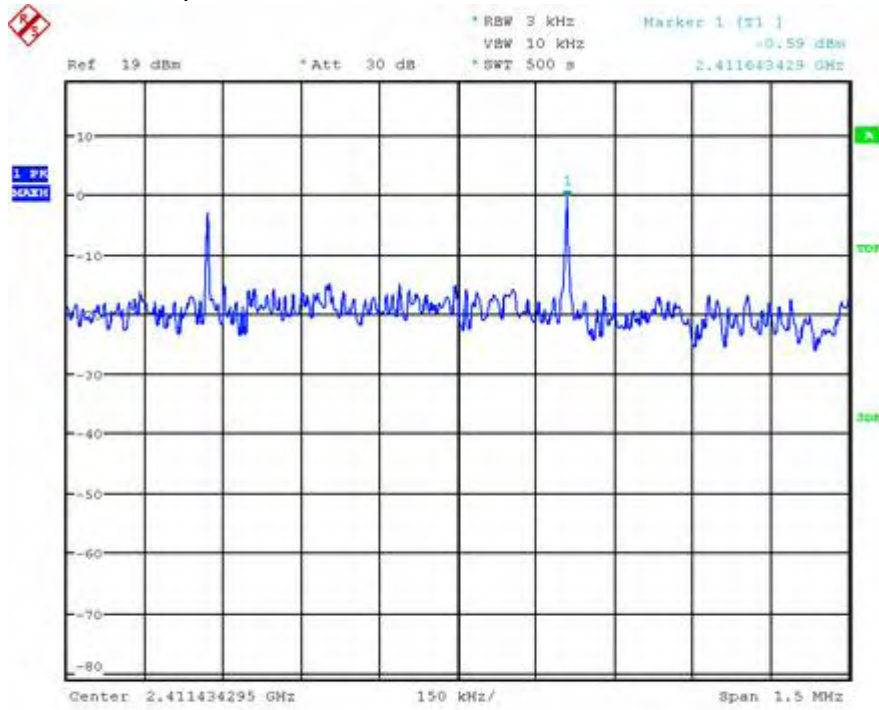

Date: 31.MAR.2011 07:47:13

802.11b, channel 6, 1Mbps

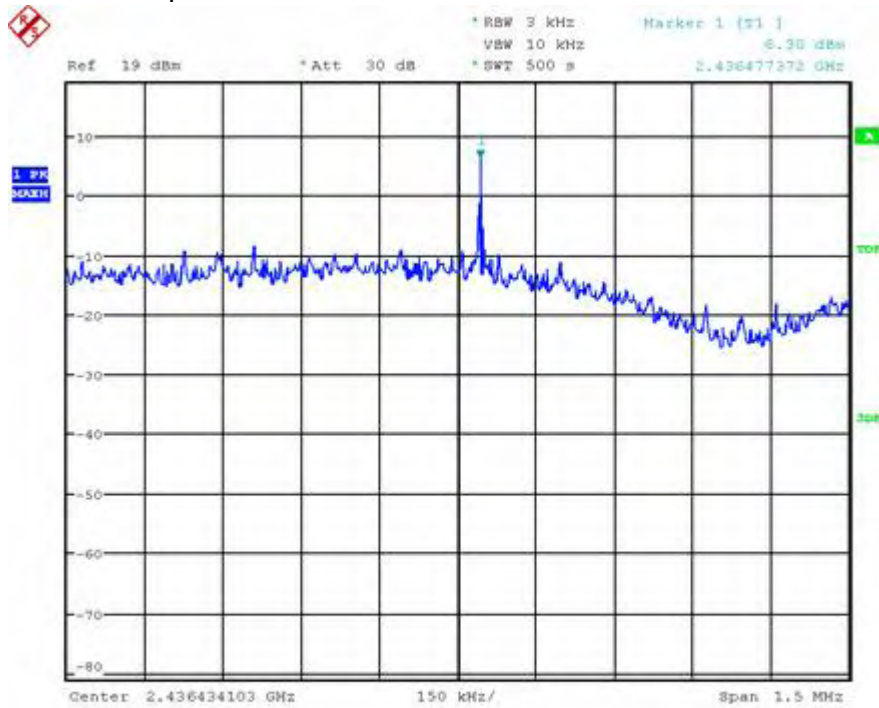

Date: 31.MAR.2011 08:16:26

802.11b, channel 6, 5.5Mbps

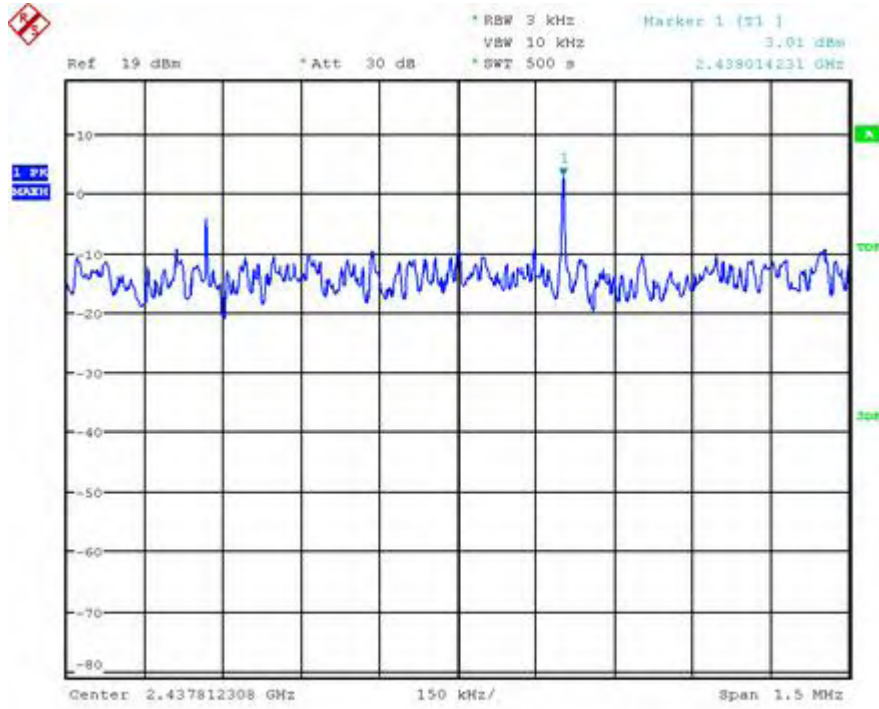

Date: 31.MAR.2011 08:27:04

802.11b, channel 6, 11Mbps

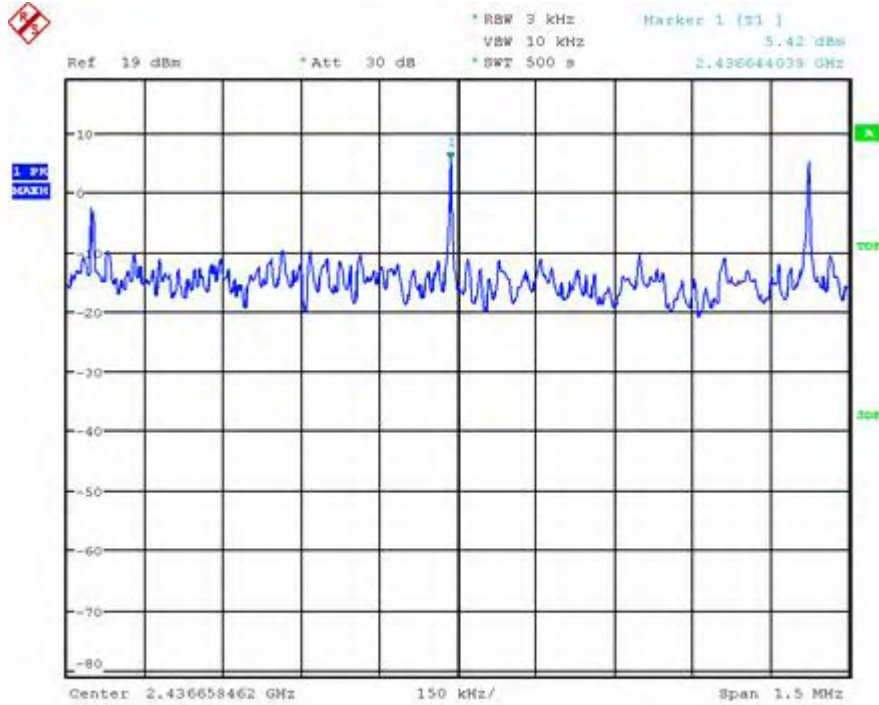

Date: 31.MAR.2011 08:46:55

802.11b, channel 11, 1Mbps

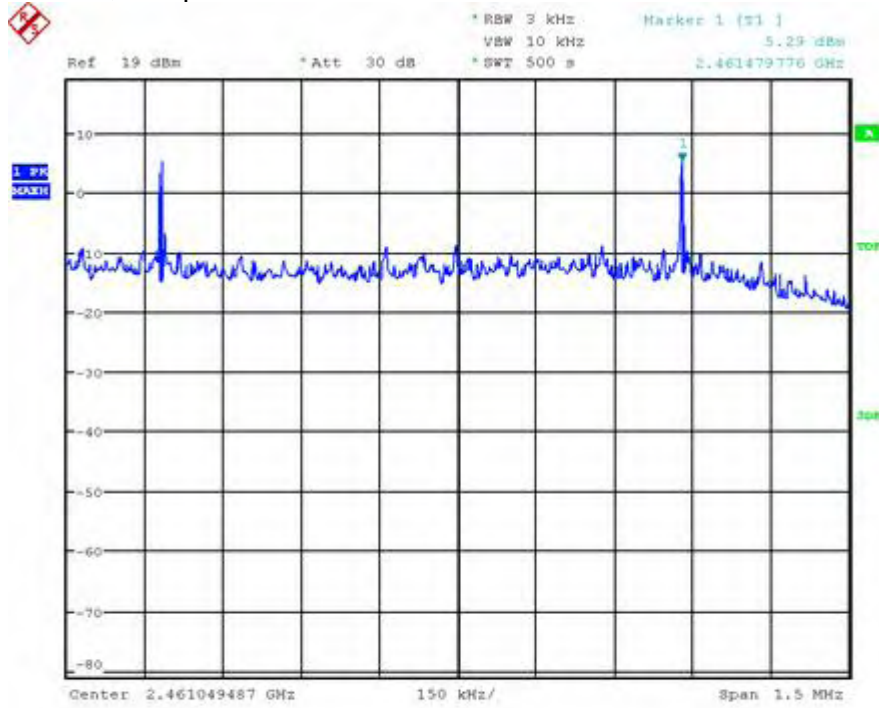

Date: 31.MAR.2011 09:08:14

802.11b, channel 11, 5.5Mbps

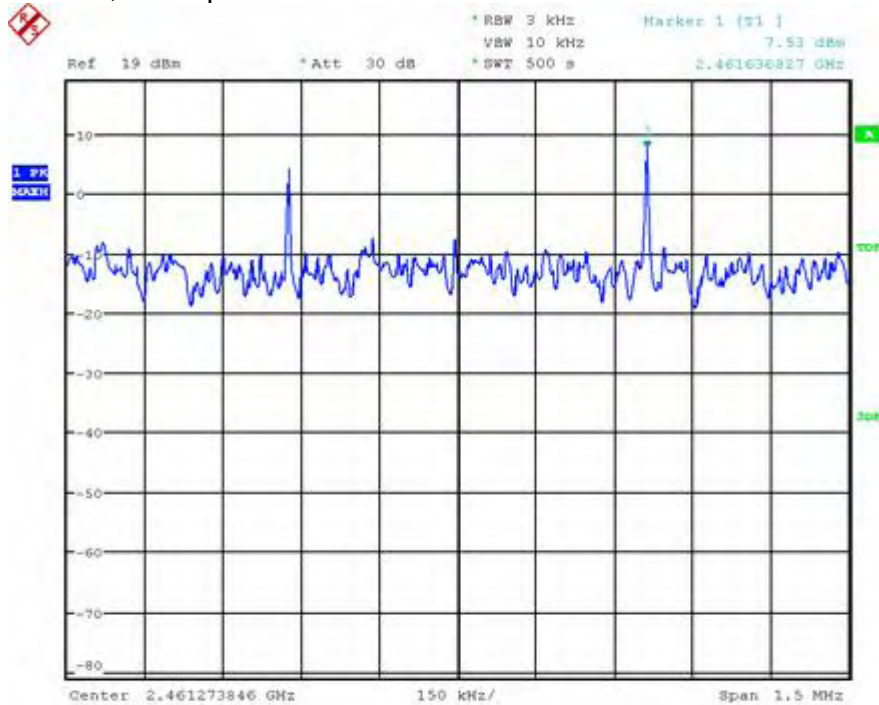

Date: 31.MAR.2011 09:21:16

802.11b, channel 11, 11Mbps

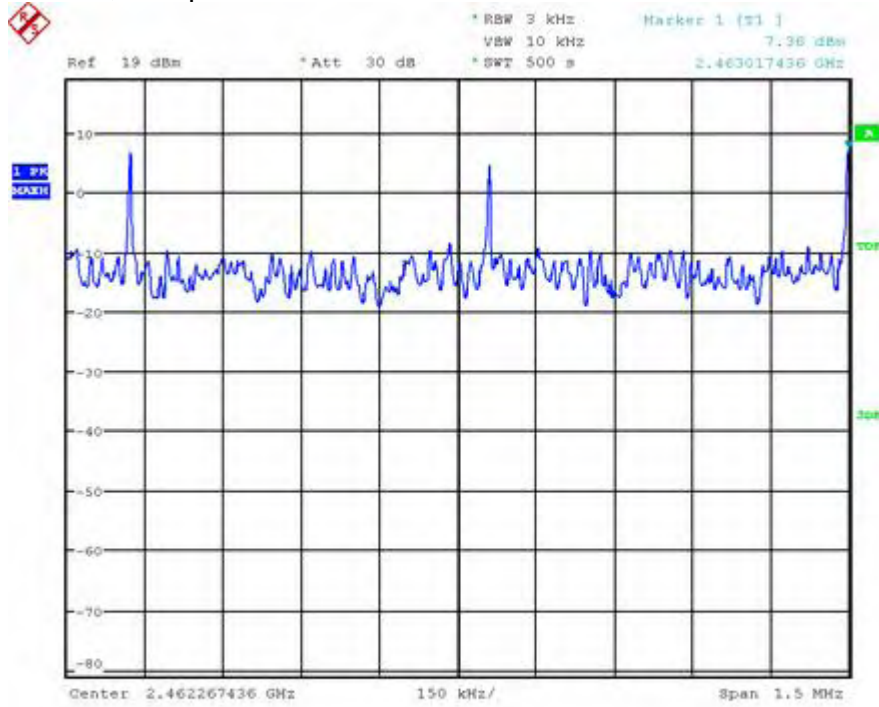

Date: 31.MAR.2011 09:31:59

802.11g, channel 1, 6Mbps

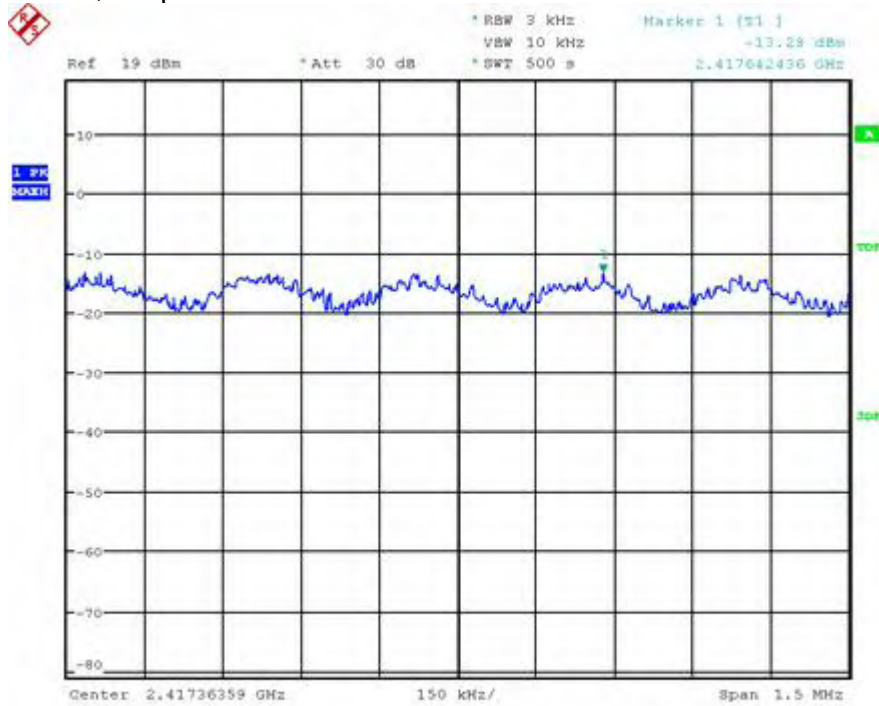

Date: 31.MAR.2011 10:27:50

802.11g, channel 1, 24Mbps

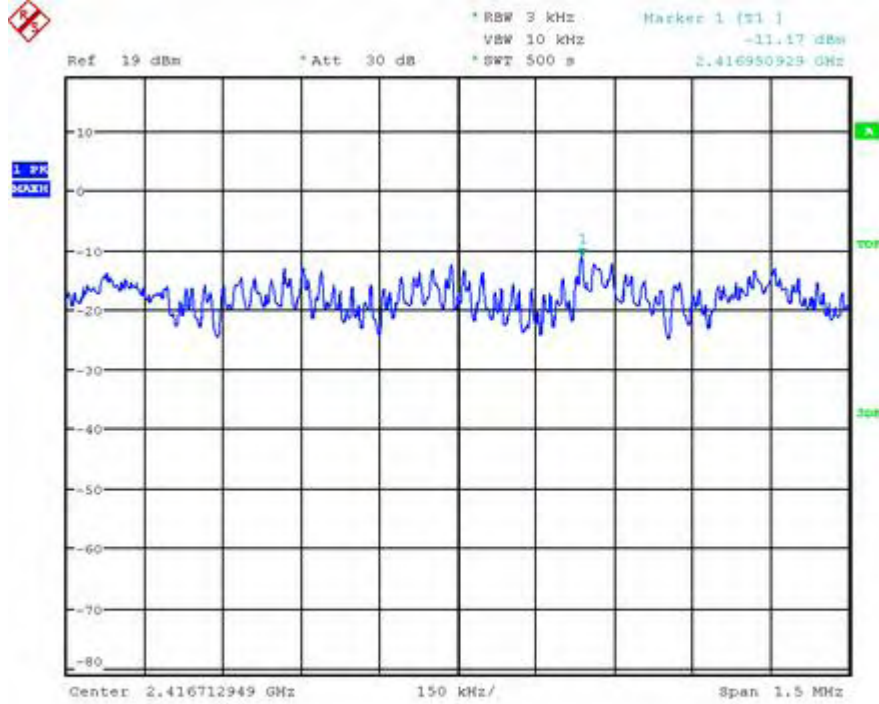

Date: 31.MAR.2011 10:39:49

802.11g, channel 1, 54Mbps

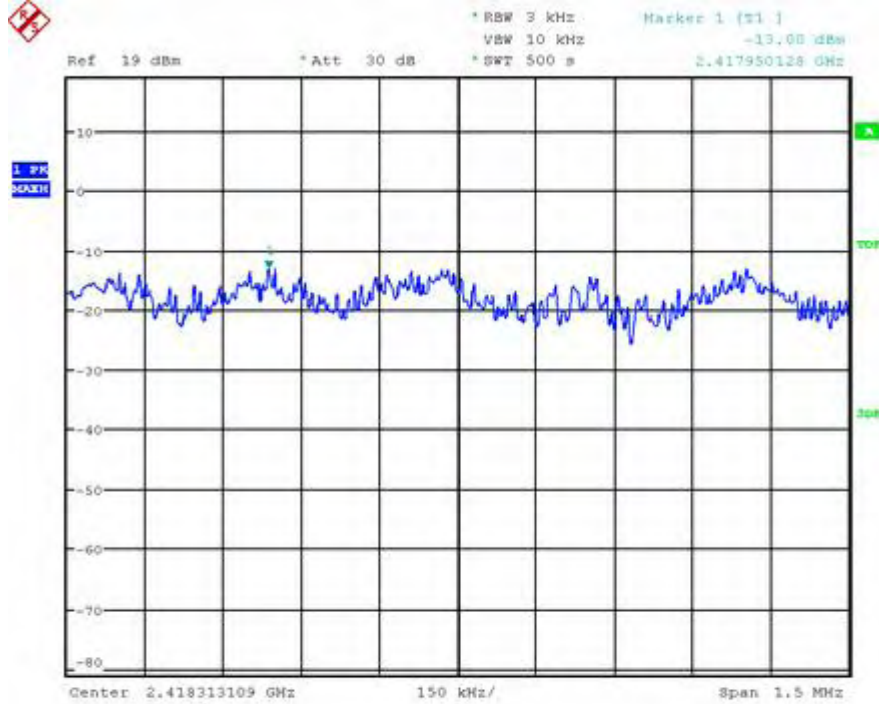

Date: 31.MAR.2011 11:02:56

802.11g, channel 6,6Mbps

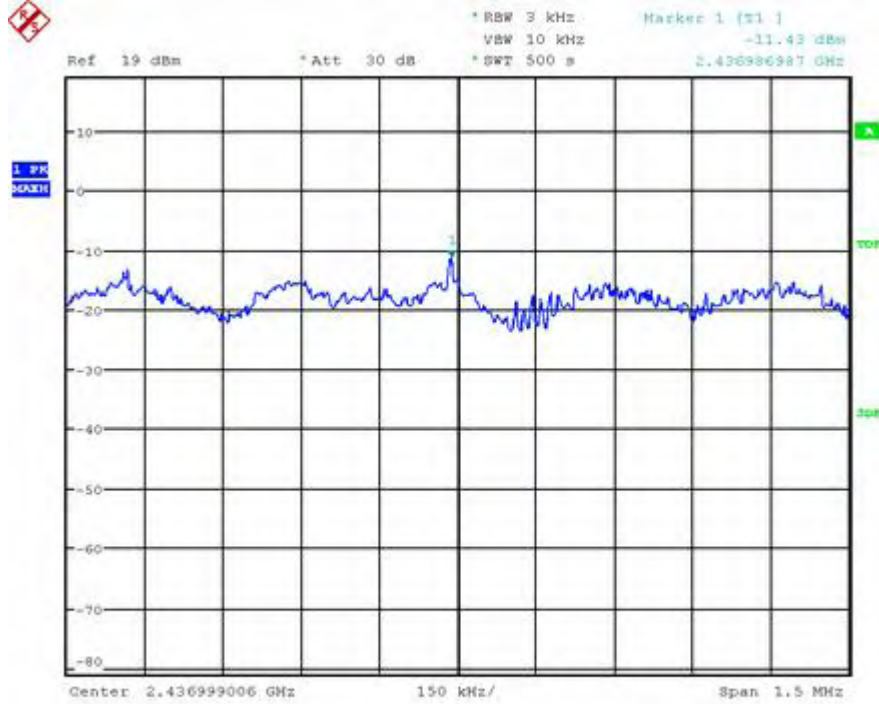

Date: 31.MAR.2011 11:26:00

802.11g, channel 6,24Mbps

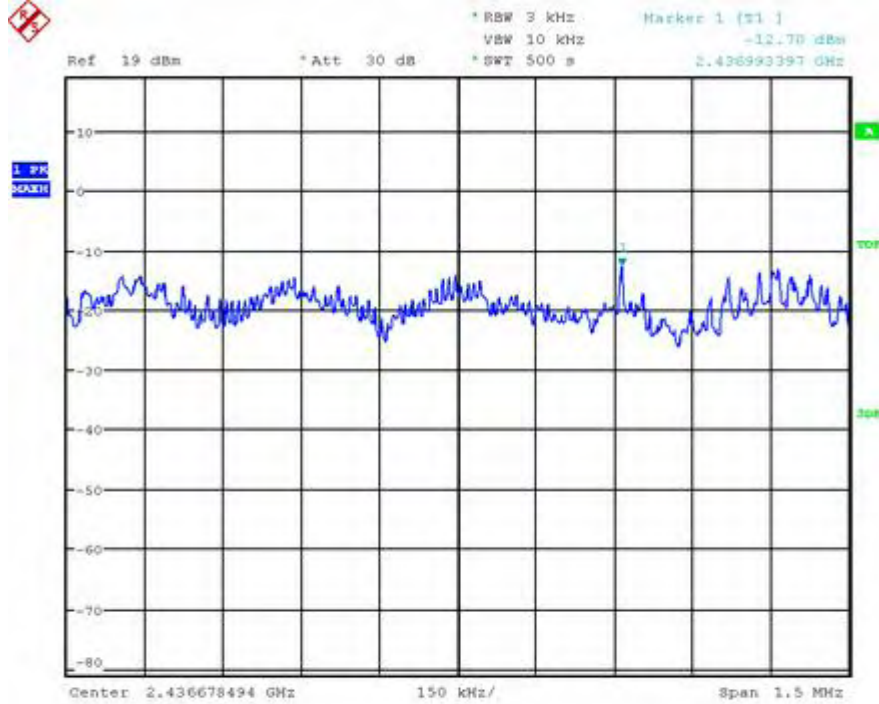

Date: 31.MAR.2011 11:44:09

802.11g, channel 6, 54Mbps

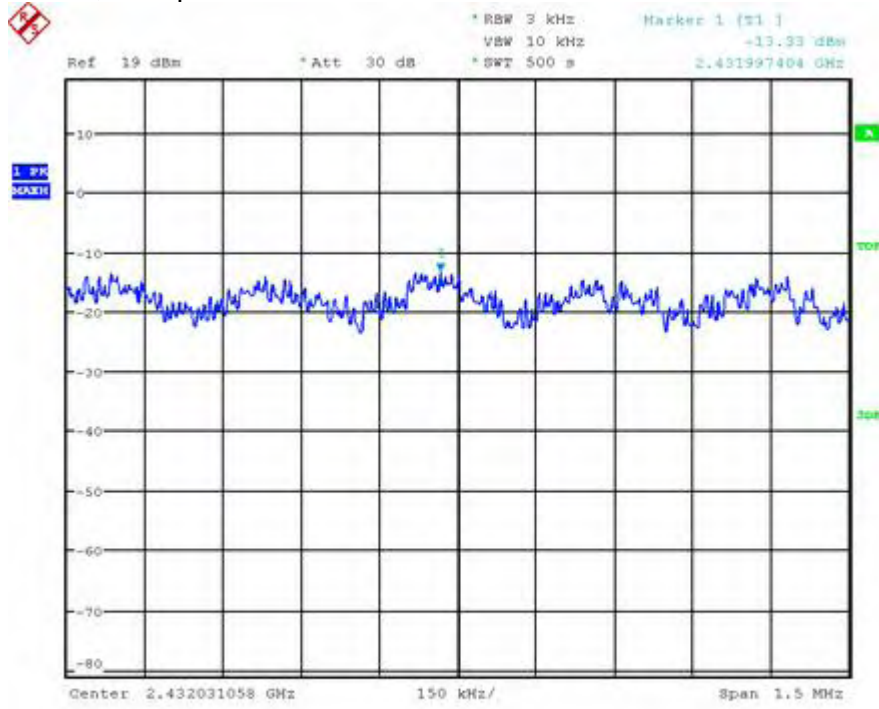

Date: 31.MAR.2011 11:55:49

802.11g, channel 11, 6Mbps

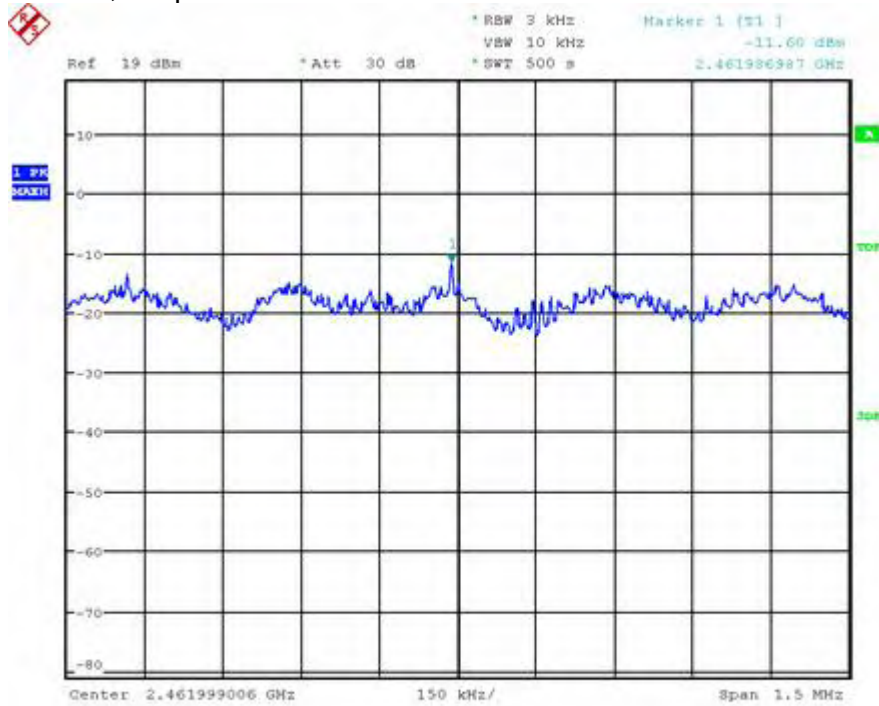

Date: 31.MAR.2011 12:08:13

802.11g, channel 11, 24Mbps

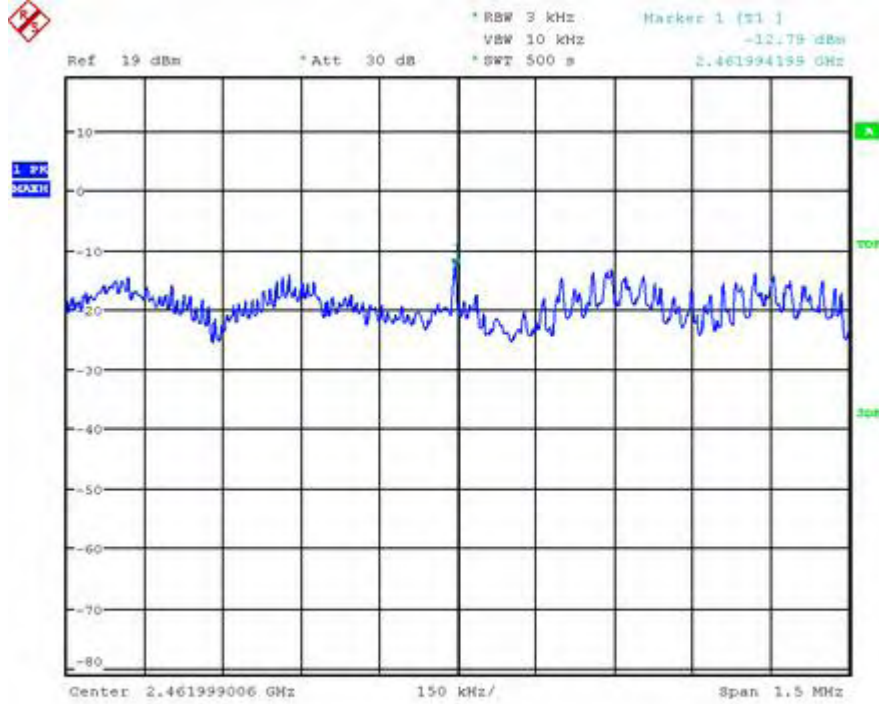

Date: 31.MAR.2011 12:23:04

802.11g, channel 11, 54Mbps

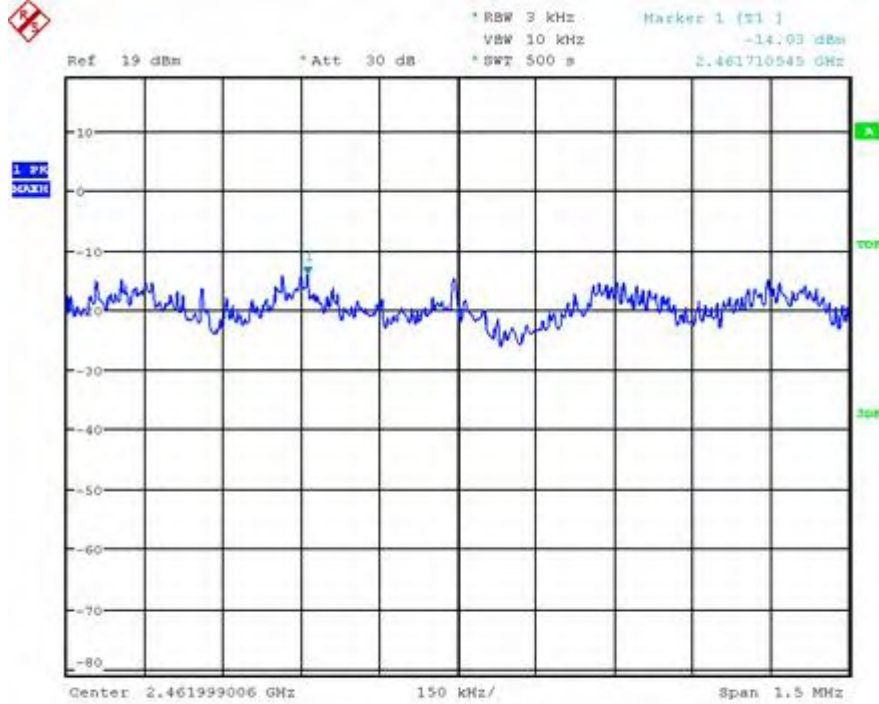

Date: 31.MAR.2011 12:34:34

4. 6 dB bandwidth

4.1. Test Equipment

The following test equipment are used during the 6 dB bandwidth test:

Item	Instrument	Manufacturer	Type No./Serial No	Due Date
1	Spectrum Analyzer	R & S	FSU 26/ 200932	2011.12.05
2	10dB Attenuator	Agilent	8493C/ 76156	2011.12.19

4.2. Test Setup

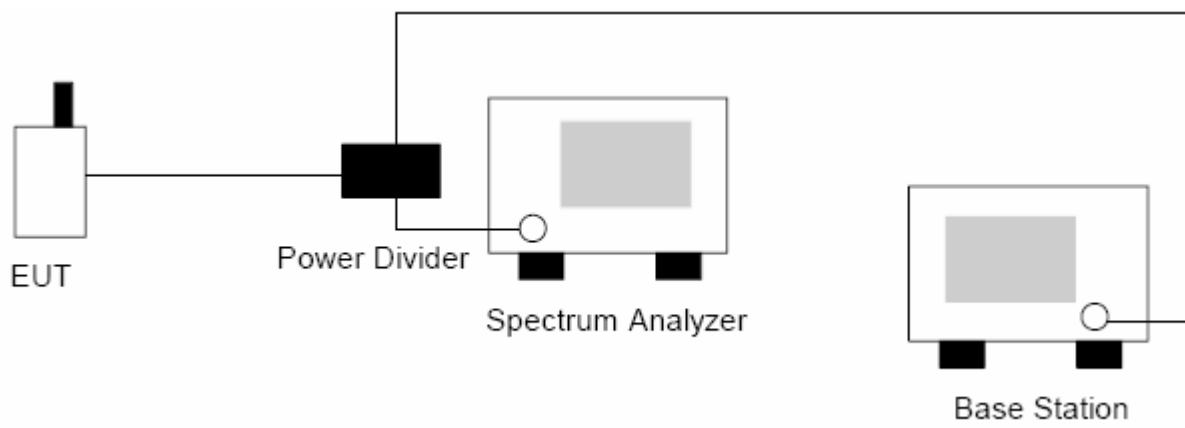

4.3. Limits

Limits	≥500 kHz
--------	----------

4.4. Test Procedure

Use the following spectrum analyzer settings:

Span = approximately 2 to 3 times the 6 dB bandwidth, centered on a channel

RBW \geq 100KHz

VBW \geq RBW

Sweep = auto

Detector function = peak

Trace = max hold

The EUT should be transmitting at its maximum data rate. Allow the trace to stabilize. Use the marker-to-peak function to set the marker to the peak of the emission. Use the marker-delta function to measure 6 dB down one side of the emission. Reset the marker-delta function, and move the marker to the other side of the emission, until it is (as close as possible to) even with the reference marker level. The marker-delta reading at this point is the 6 dB bandwidth of the emission. If this value varies with different modes of operation (e.g., data rate, modulation format, etc.), repeat this test for each variation.

4.5. Test Specification

According to CFR 47 FCC Part 15.247

4.6. EUT Operation

See chapter 1.2 of this test report.

4.7. Test Result

channel	mode	Data Rate (Mbps)	Measured 6dB bandwidth (MHz)	Limit (kHz)	Result
1	802.11b	1	10.06	≥500	Pass
		5.5	11.06	≥500	Pass
		11	9.05	≥500	Pass
	802.11g	6	16.35	≥500	Pass
		24	16.39	≥500	Pass
		54	16.50	≥500	Pass
6	802.11b	1	10.06	≥500	Pass
		5.5	10.14	≥500	Pass
		11	10.14	≥500	Pass
	802.11g	6	16.11	≥500	Pass
		24	16.36	≥500	Pass
		54	16.32	≥500	Pass
11	802.11b	1	9.09	≥500	Pass
		5.5	9.71	≥500	Pass
		11	8.33	≥500	Pass
	802.11g	6	16.06	≥500	Pass
		24	16.04	≥500	Pass
		54	16.28	≥500	Pass

802.11b, channel 1, 1Mbps

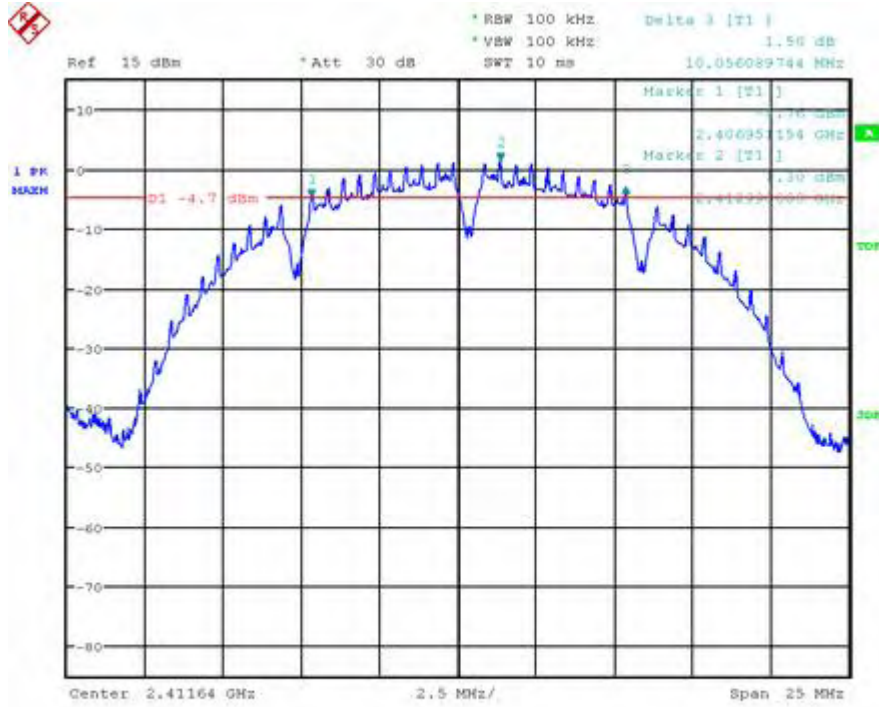

Date: 11.APR.2011 04:29:44

802.11b, channel 1, 5.5Mbps

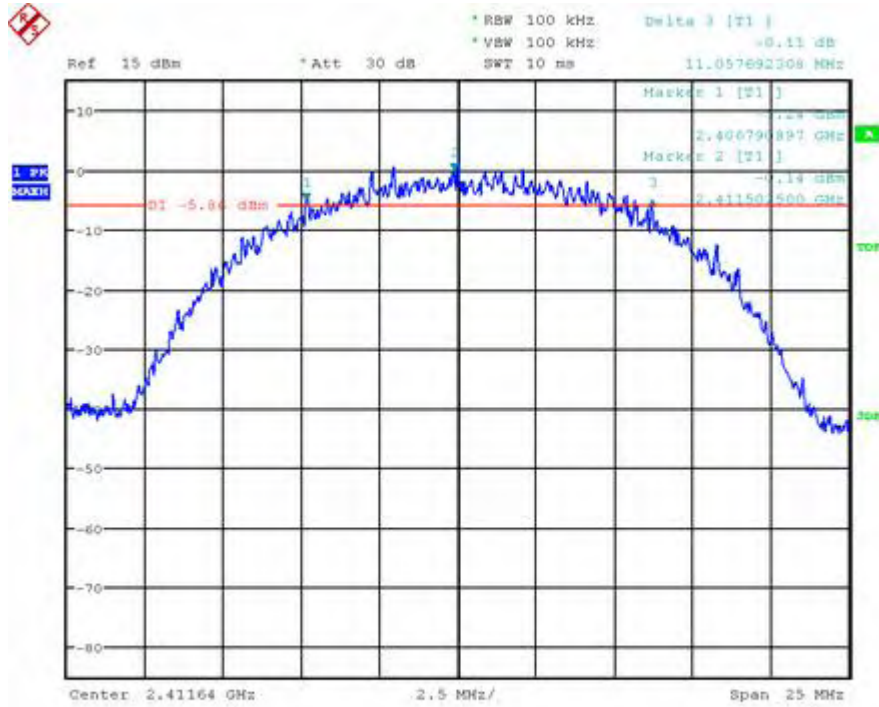

Date: 11.APR.2011 04:31:51

802.11b, channel 1, 11Mbps

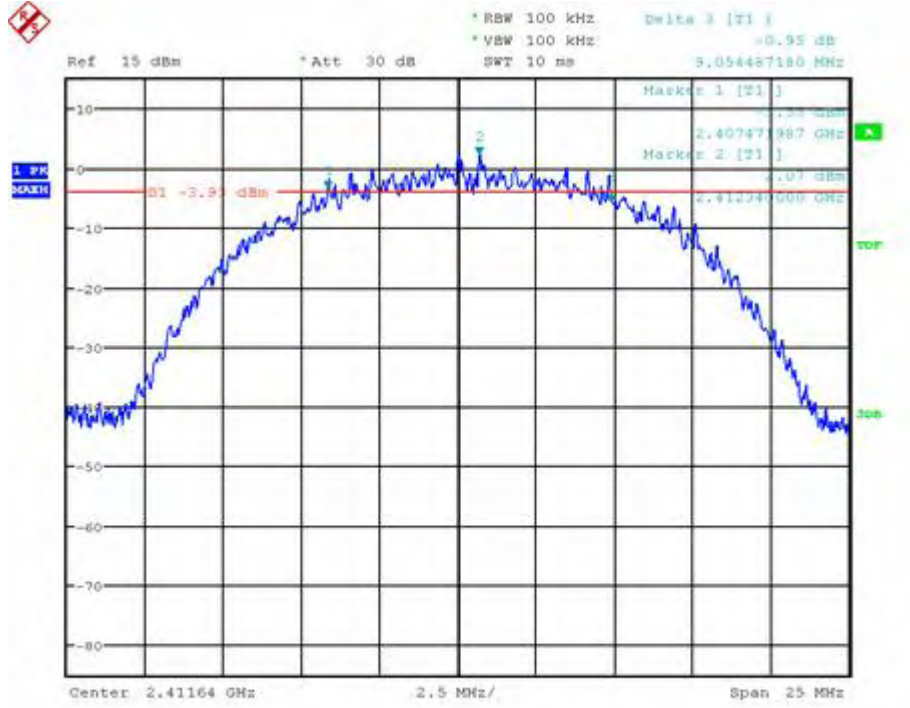

Date: 11.APR.2011 04:38:39

802.11b, channel 6, 1Mbps



Date: 11.APR.2011 05:05:36

802.11b, channel 6, 5.5Mbps



Date: 11.APR.2011 05:08:32

802.11b, channel 6, 11Mbps

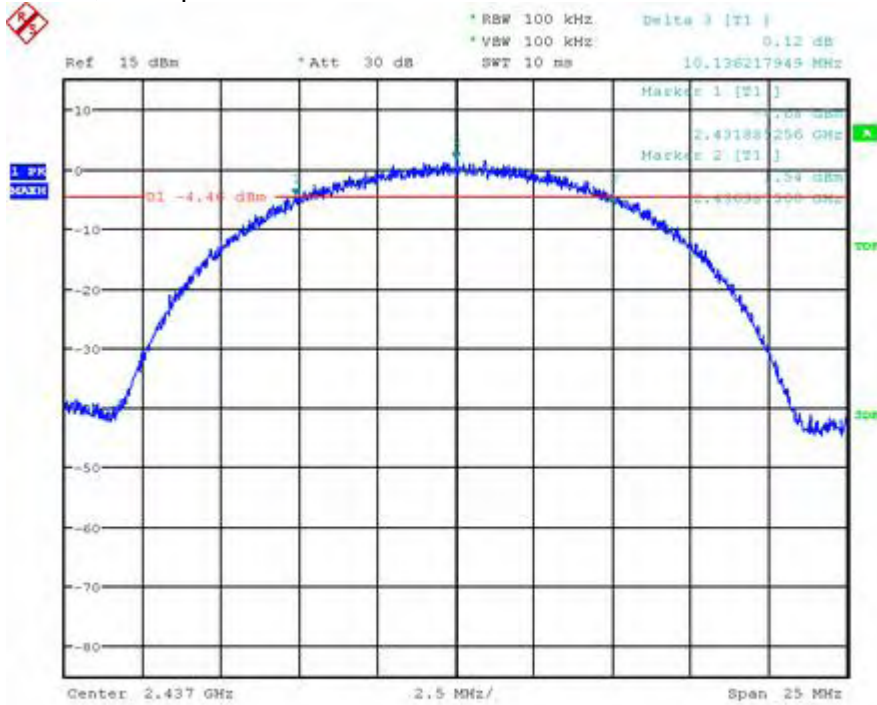

Date: 11.APR.2011 05:10:29

802.11b, channel 11, 1Mbps

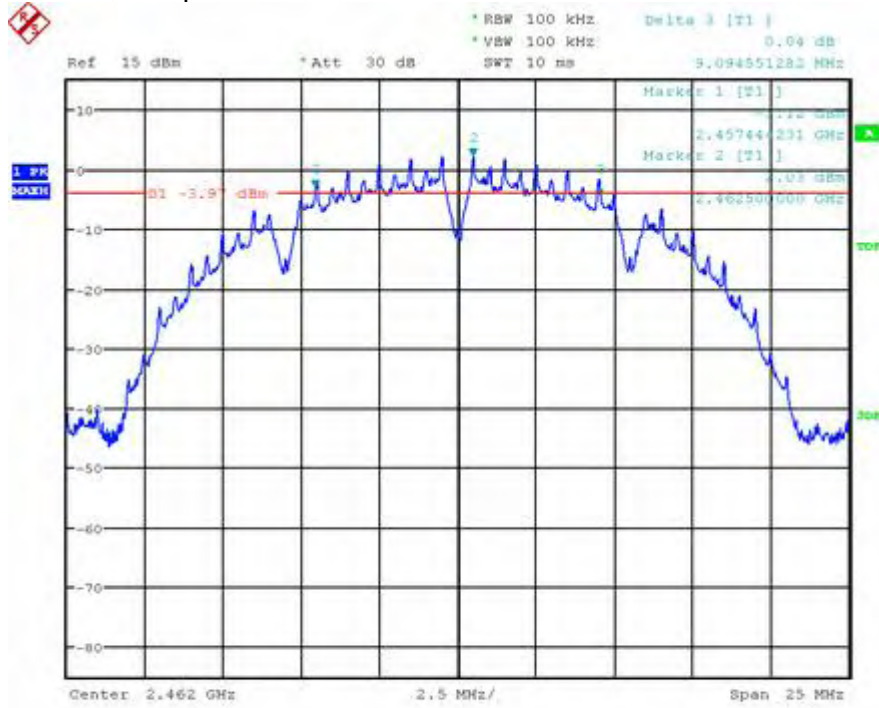

Date: 11.APR.2011 06:18:27

802.11b, channel 11, 5.5Mbps

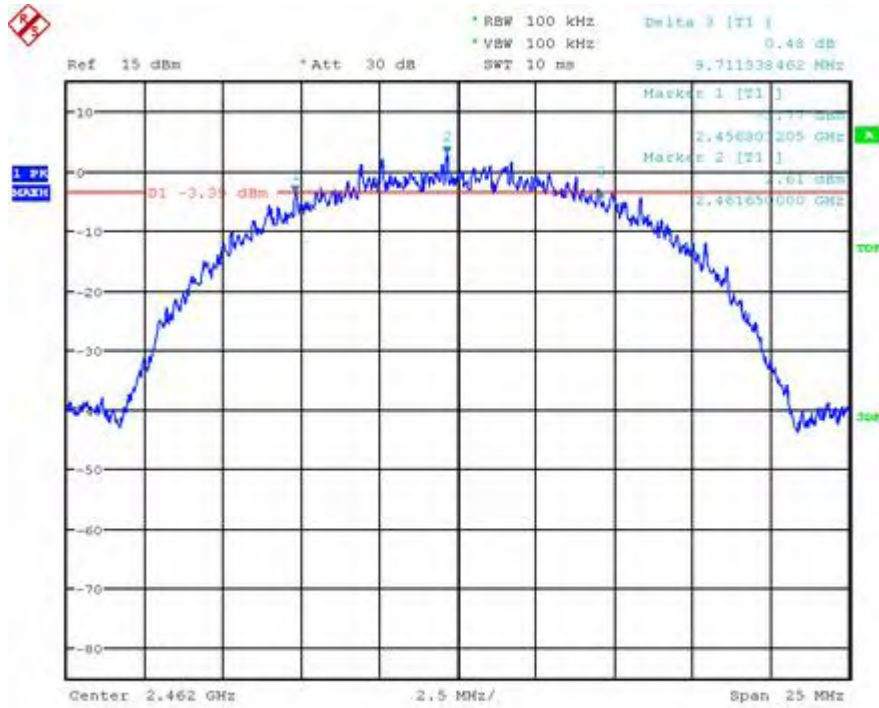

Date: 11.APR.2011 07:01:04

802.11b, channel 11, 11Mbps

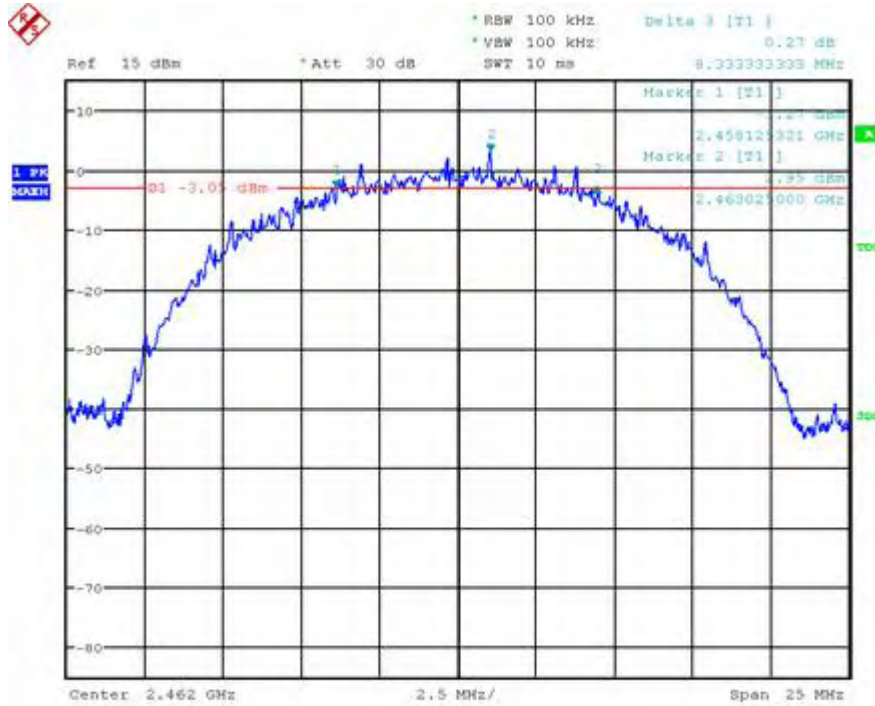

Date: 11.APR.2011 06:22:12

802.11g, channel 1, 6Mbps

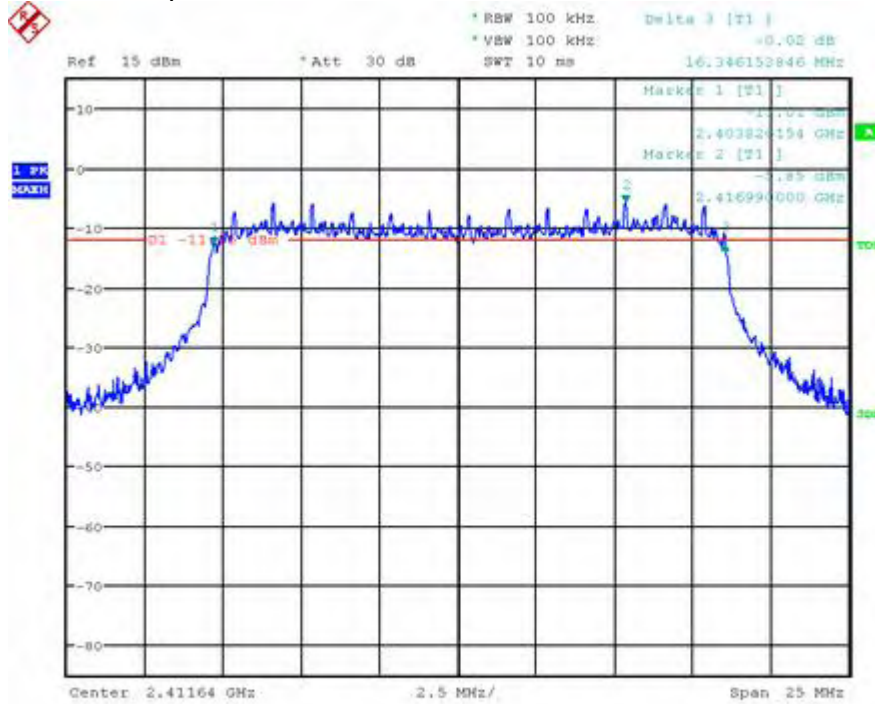

Date: 11.APR.2011 04:49:52

802.11g, channel 1, 24Mbps

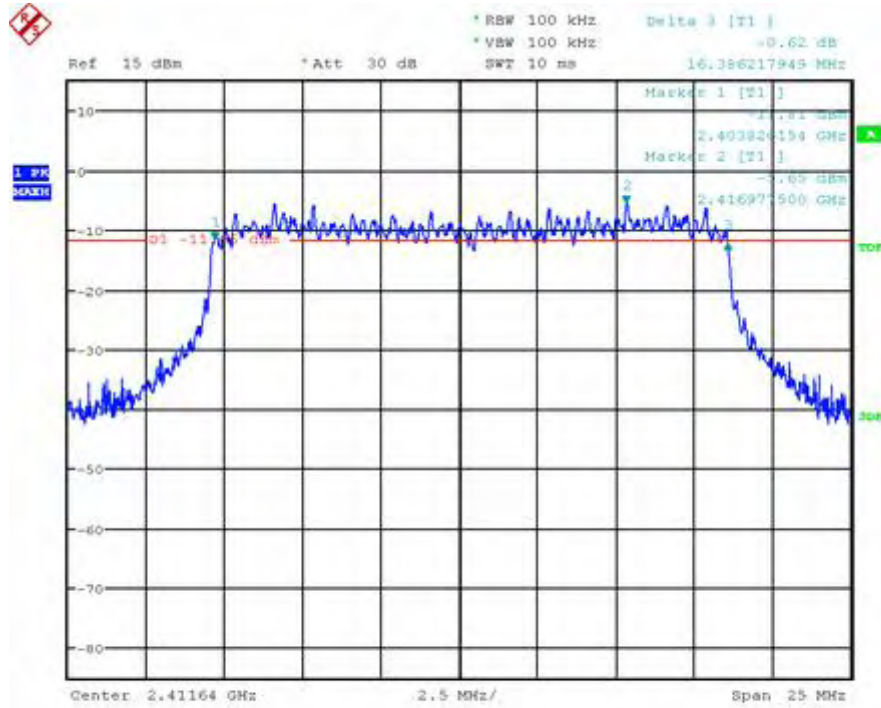

Date: 11.APR.2011 04:57:05

802.11g, channel 1, 54Mbps

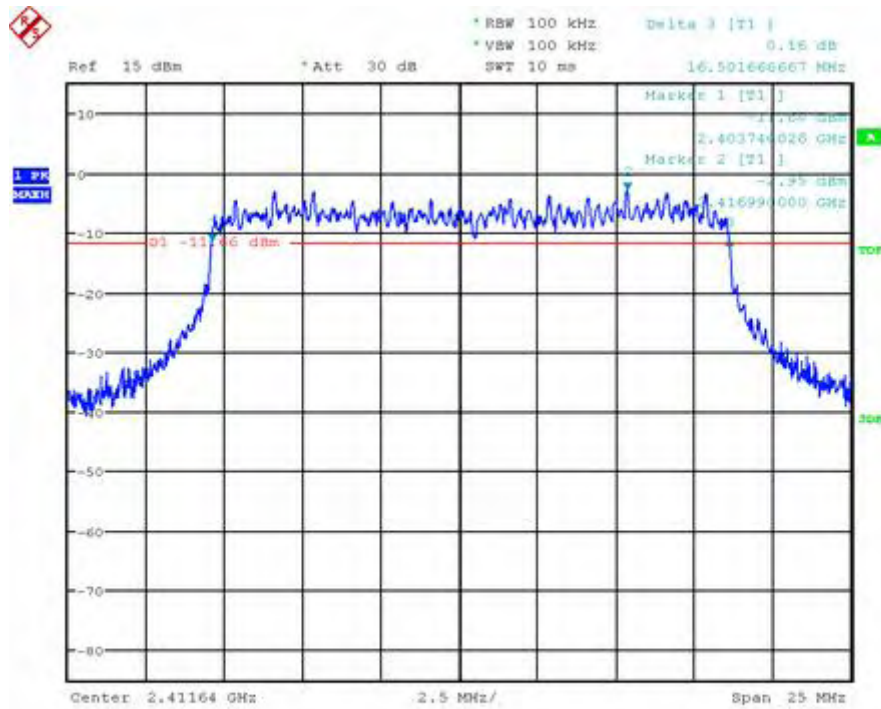

Date: 11.APR.2011 05:01:13

802.11g, channel 6, 6Mbps

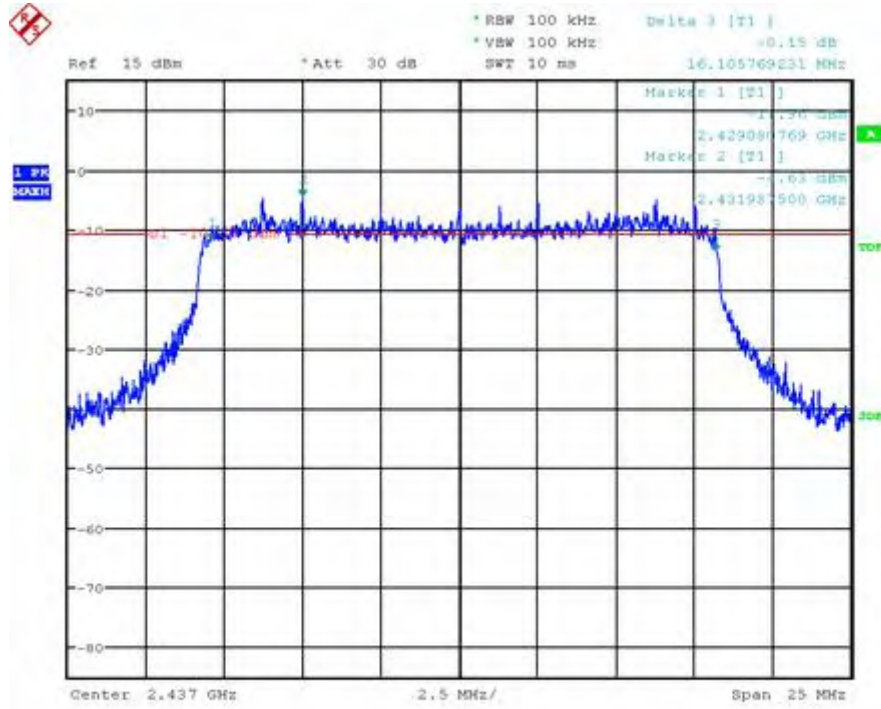

Date: 11.APR.2011 05:32:37

802.11g, channel 6, 24Mbps

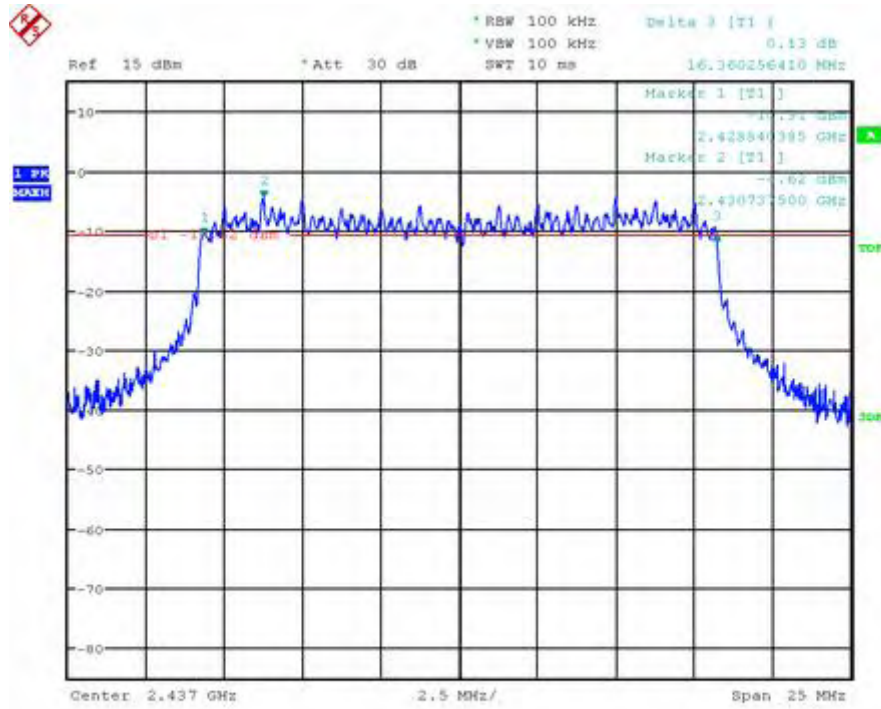

Date: 11.APR.2011 05:34:43

802.11g, channel 6, 54Mbps

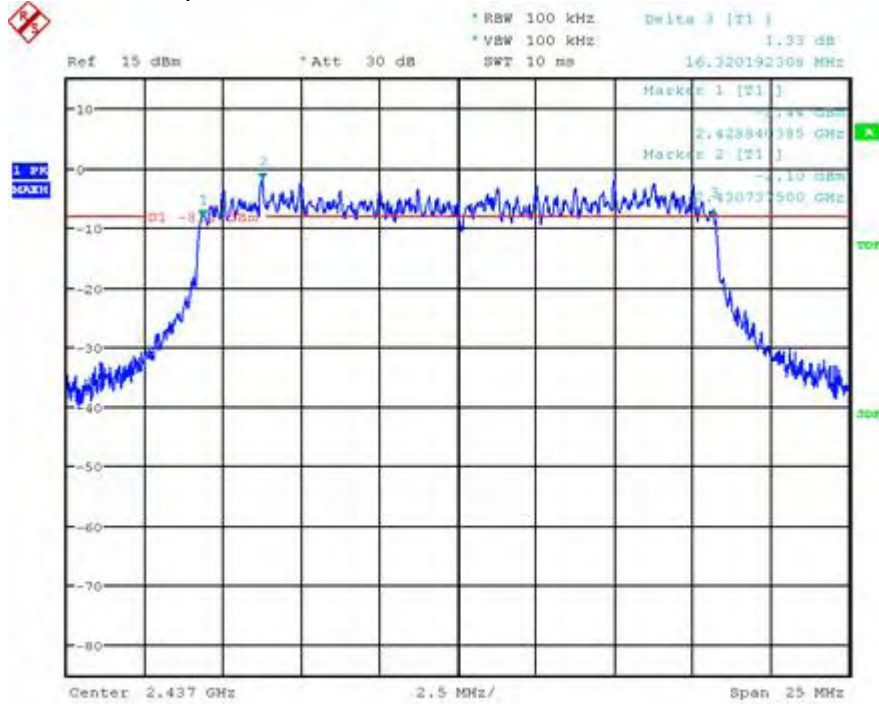

Date: 11.APR.2011 05:39:34

802.11g, channel 11, 6Mbps

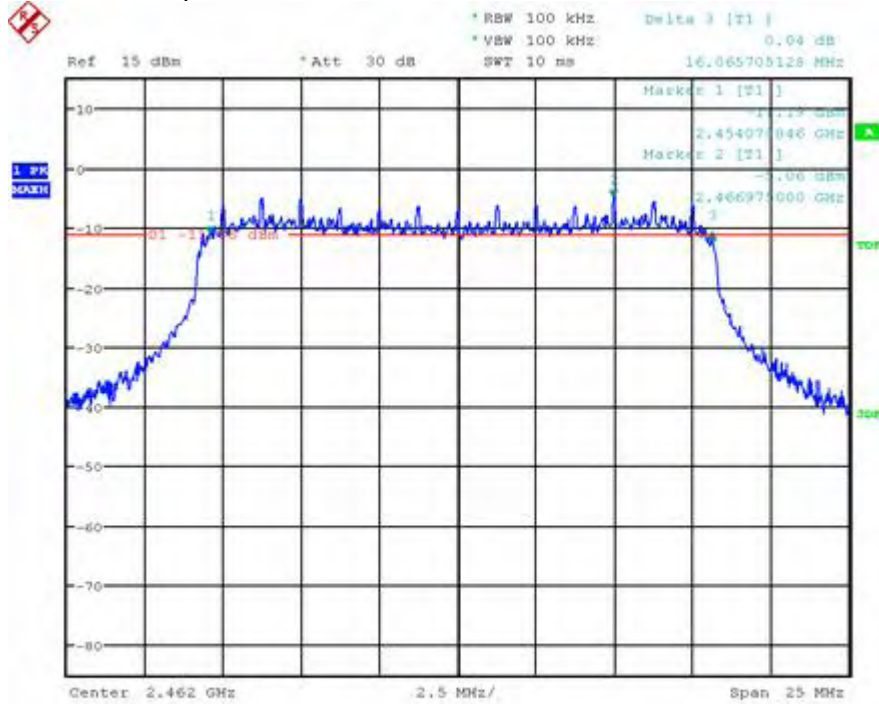

Date: 11.APR.2011 06:27:11

802.11g, channel 11, 24Mbps

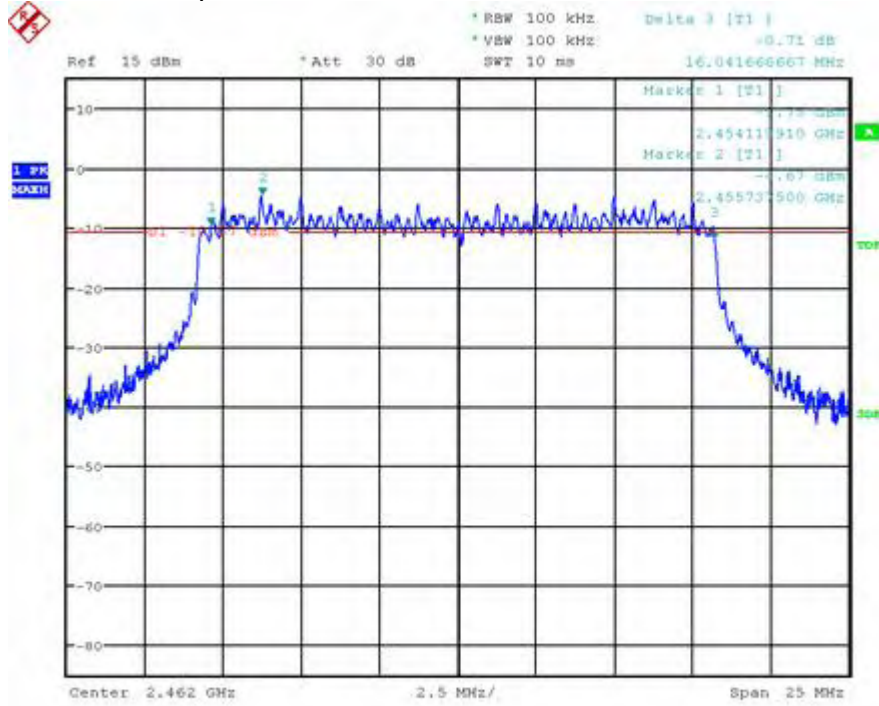

Date: 11.APR.2011 06:30:58

802.11g, channel 11, 54Mbps

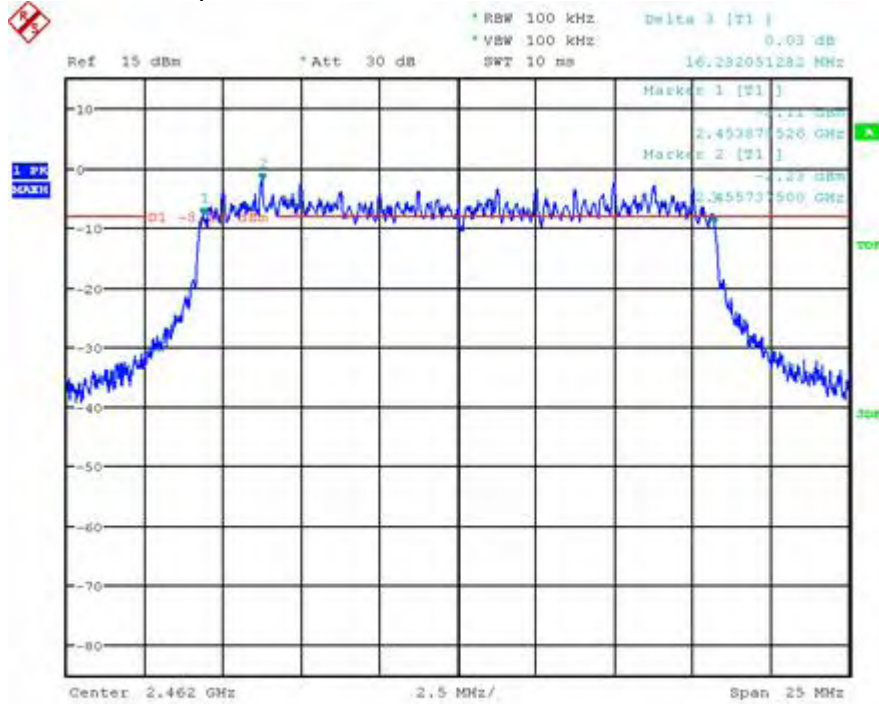

Date: 11.APR.2011 06:34:08

5. Peak Output Power (Conduction)

5.1. Test Equipment

The following test equipment are used during the Peak Output Power (Conduction) test:

Item	Instrument	Manufacturer	Type No./Serial No	Due Date
1	Spectrum Analyzer	R & S	FSU 26/ 200932	2011.12.05

5.2. Test Setup

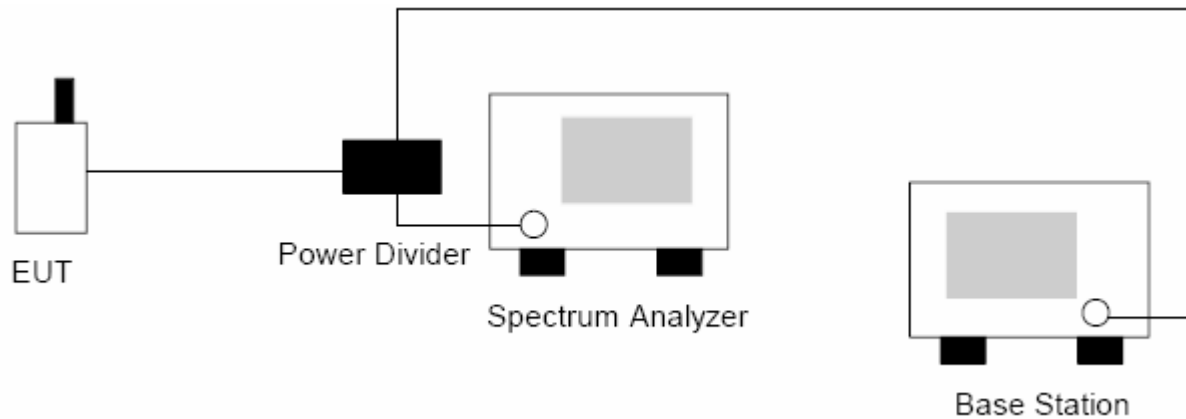

5.3. Limits

Limits	<30dBm
--------	--------

5.4. Test Procedure

The output power of the cell signal of the testing equipment will be increased until the output power of the EUT reach a maximum value. Then the test data can be read at the tester screen. The loss between RF output port of the EUT and the input port of the tester will be taken into consideration.

The measurement will be conducted at different three channels.

Use the following spectrum analyzer settings:

RBW≥EBW; VBW≥ RBW; Detector function = peak; Trace = max hold

5.5. Test Specification

According to CFR 47 FCC Part 15.247

5.6. EUT Operation

See chapter 1.2 of this test report.

5.7. Test Result

channel	mode	Data Rate (Mbps)	Frequency measured (MHz)	Cable loss (dB)	Measurement result (dBm)	Carrier power (dBm)	Limit (dBm)	Result
1	802.11b	1	2412	0.56	13.69	14.25	<30.00	Pass
		5.5	2412	0.56	13.27	13.83	<30.00	Pass
		11	2412	0.56	12.90	13.46	<30.00	pass
	802.11g	6	2412	0.56	16.14	16.70	<30.00	Pass
		24	2412	0.56	15.98	16.64	<30.00	Pass
		54	2412	0.56	17.65	18.21	<30.00	pass
6	802.11b	1	2437	0.67	13.41	14.08	<30.00	Pass
		5.5	2437	0.67	12.49	13.16	<30.00	Pass
		11	2437	0.67	12.53	13.20	<30.00	pass
	802.11g	6	2437	0.67	17.05	17.72	<30.00	Pass
		24	2437	0.67	17.18	17.85	<30.00	Pass
		54	2437	0.67	17.25	17.92	<30.00	pass
11	802.11b	1	2462	0.72	13.27	13.99	<30.00	Pass
		5.5	2462	0.72	13.05	13.77	<30.00	Pass
		11	2462	0.72	13.42	14.14	<30.00	pass
	802.11g	6	2462	0.72	16.60	17.32	<30.00	Pass
		24	2462	0.72	16.97	17.69	<30.00	Pass
		54	2462	0.72	16.90	17.62	<30.00	pass

802.11b, channel 1, 1Mbps

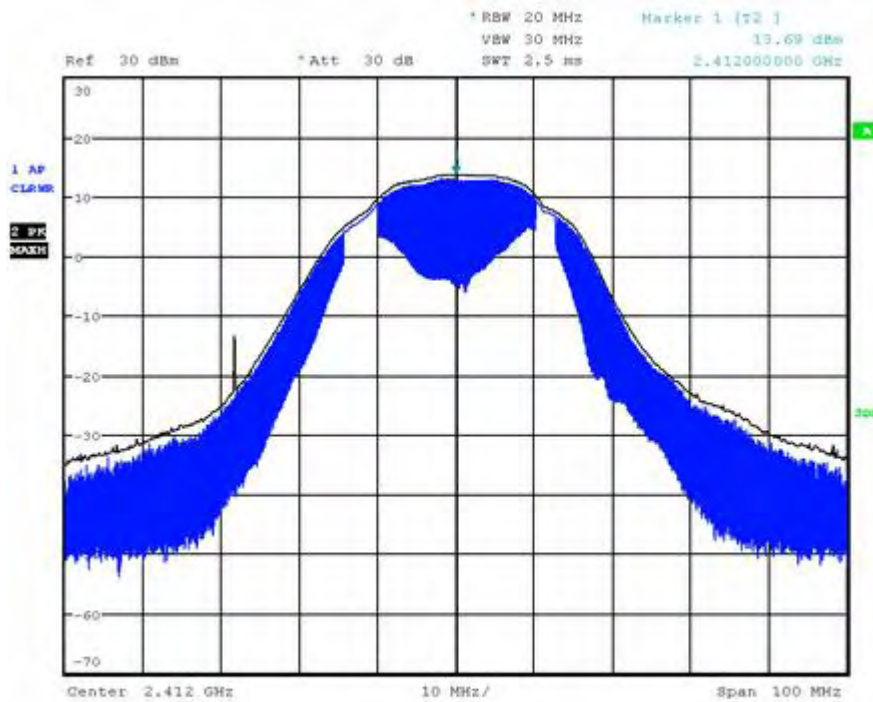

Date: 16.MAY.2011 10:50:52

802.11b, channel 1, 5.5Mbps

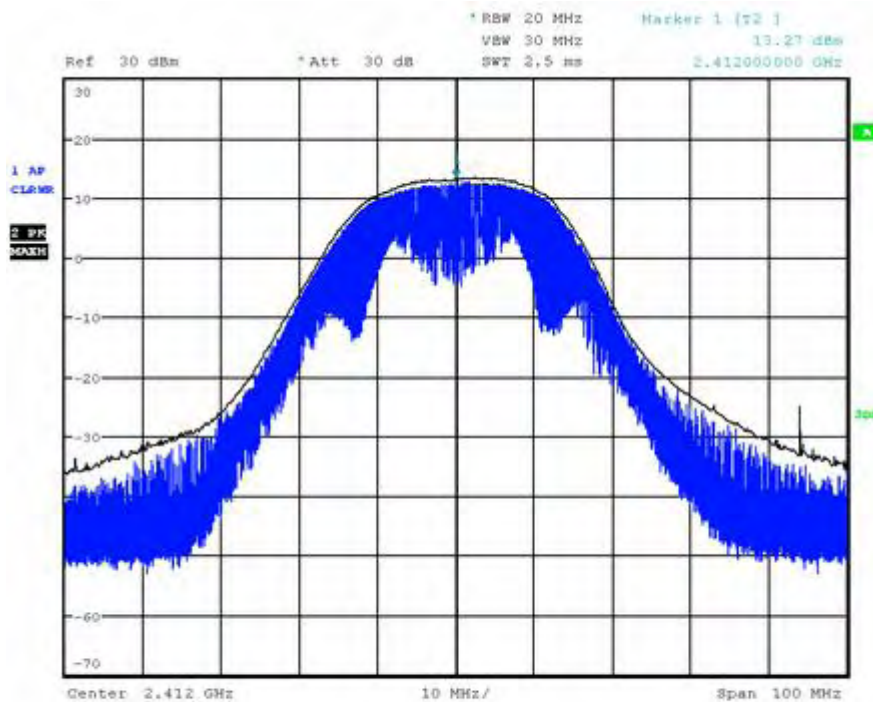

Date: 16.MAY.2011 10:51:55

802.11b, channel 1, 11Mbps

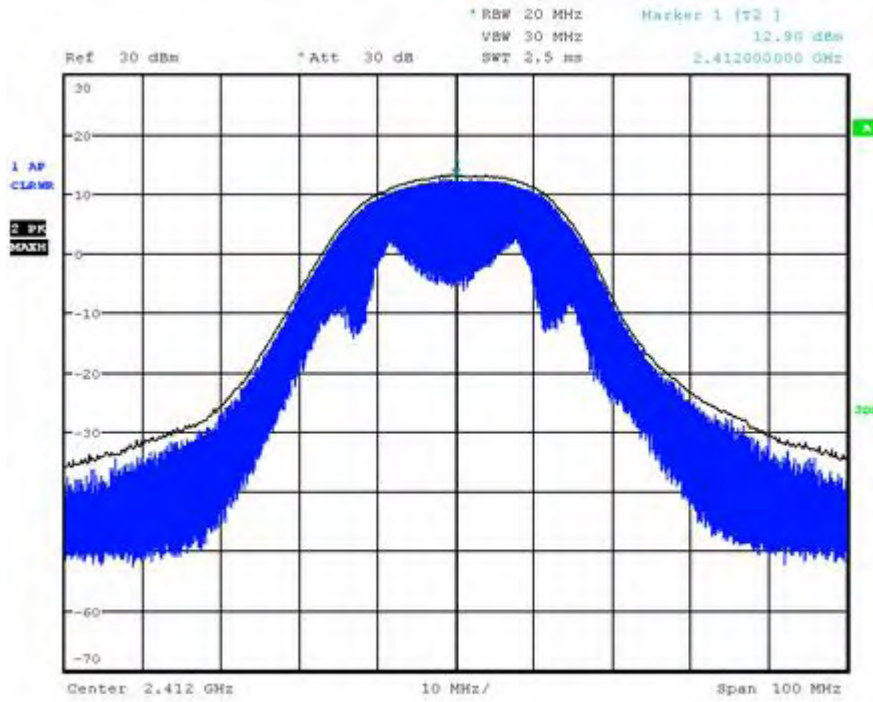

Date: 16.MAY.2011 10:52:49

802.11b, channel 6, 1Mbps

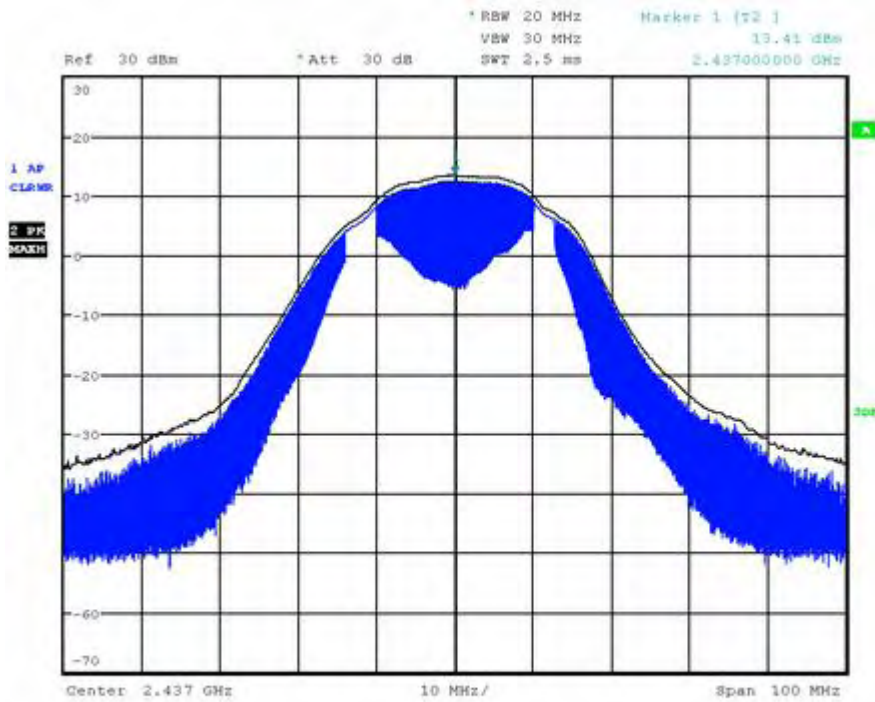

Date: 16.MAY.2011 10:16:39

802.11b, channel 6, 5.5Mbps

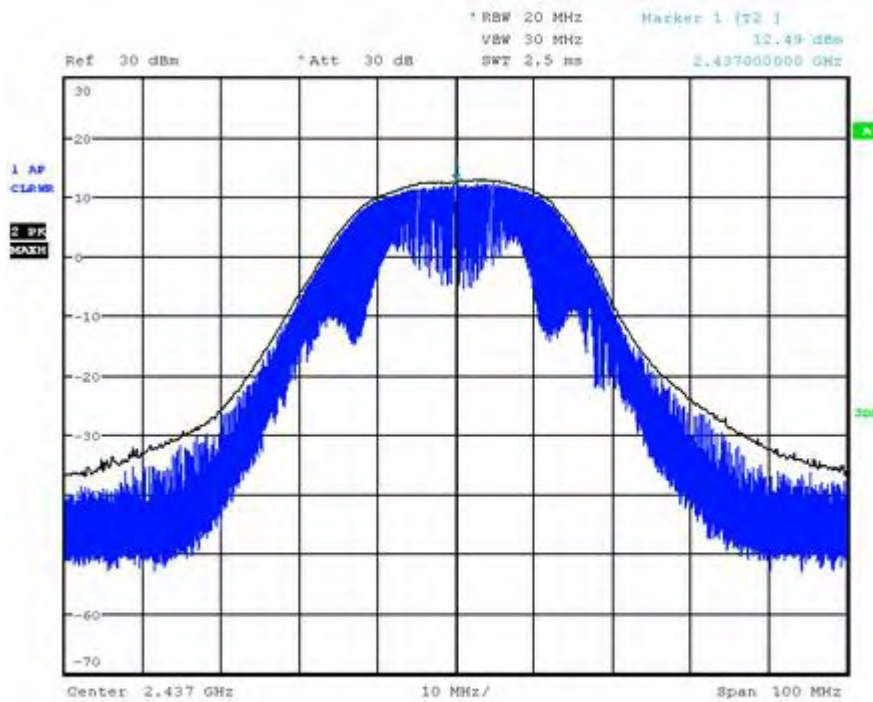

Date: 16.MAY.2011 10:17:32

802.11b, channel 6, 11Mbps

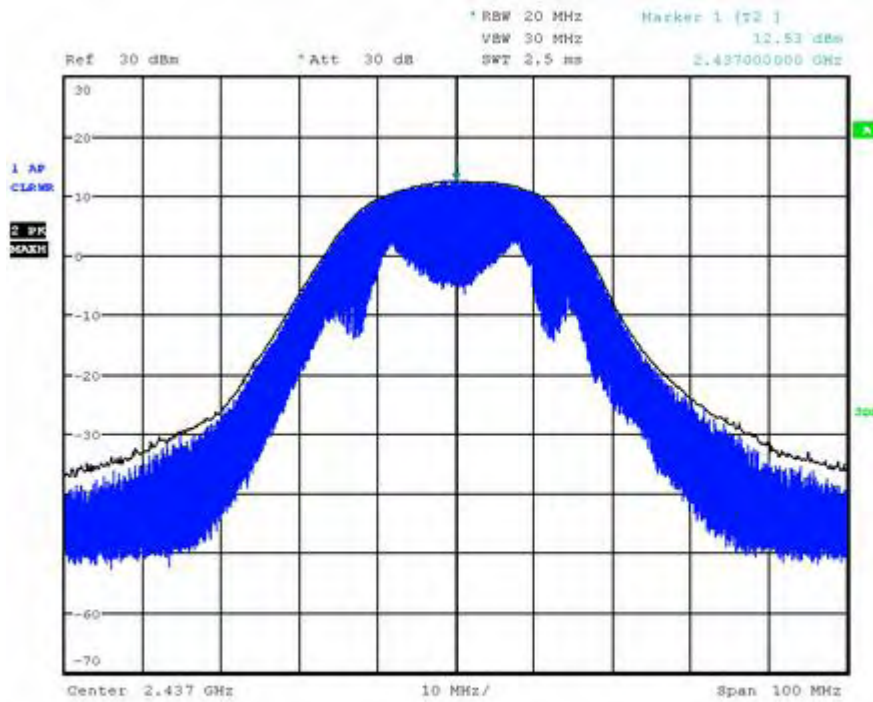

Date: 16.MAY.2011 10:18:57

802.11b, channel 11, 1Mbps

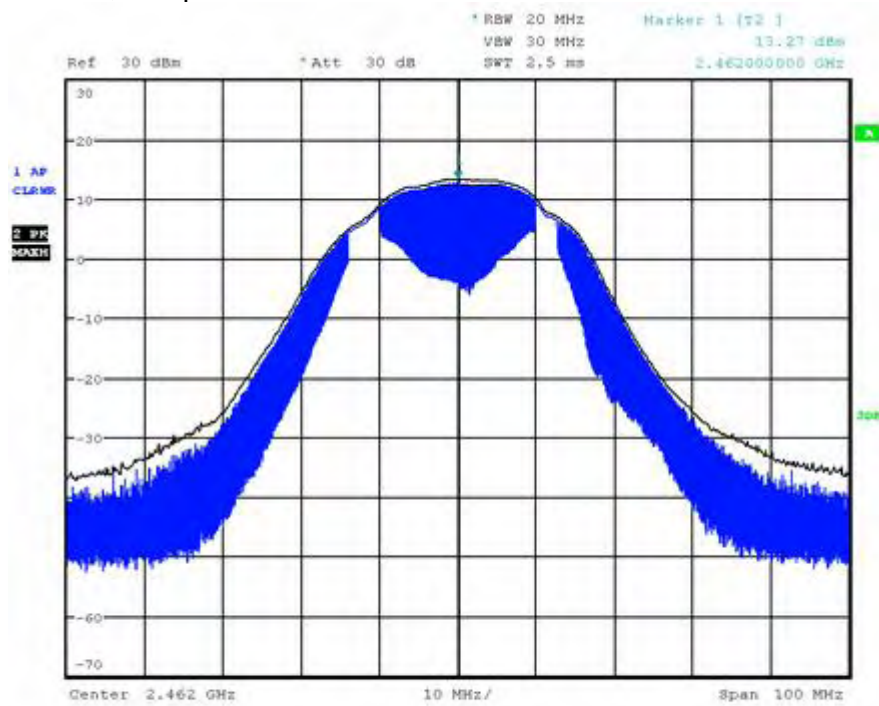

Date: 16.MAY.2011 10:25:14

802.11b, channel 11, 5.5Mbps

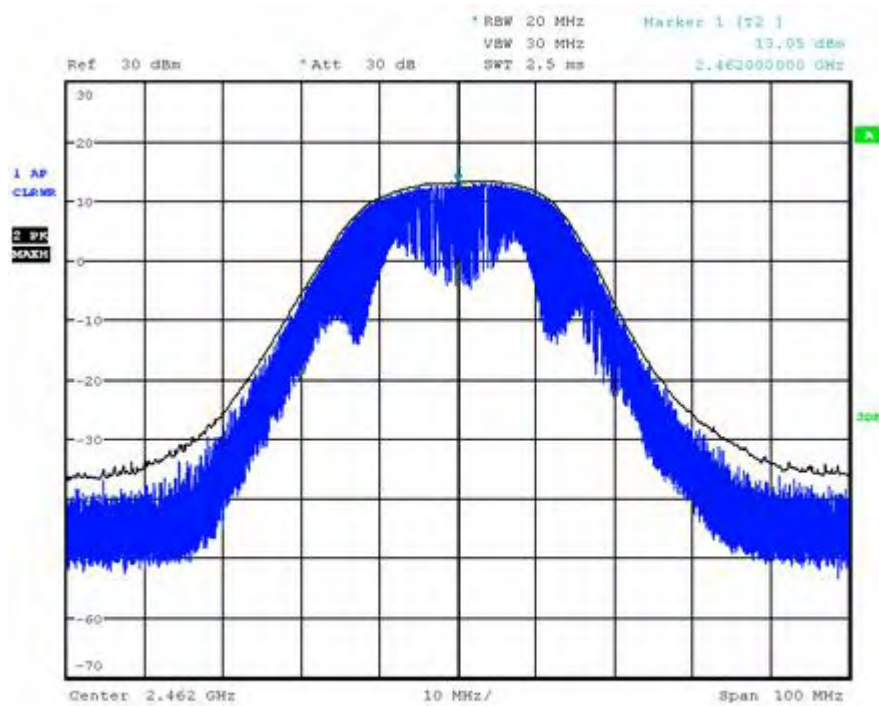

Date: 16.MAY.2011 10:26:23

802.11b, channel 11, 11Mbps

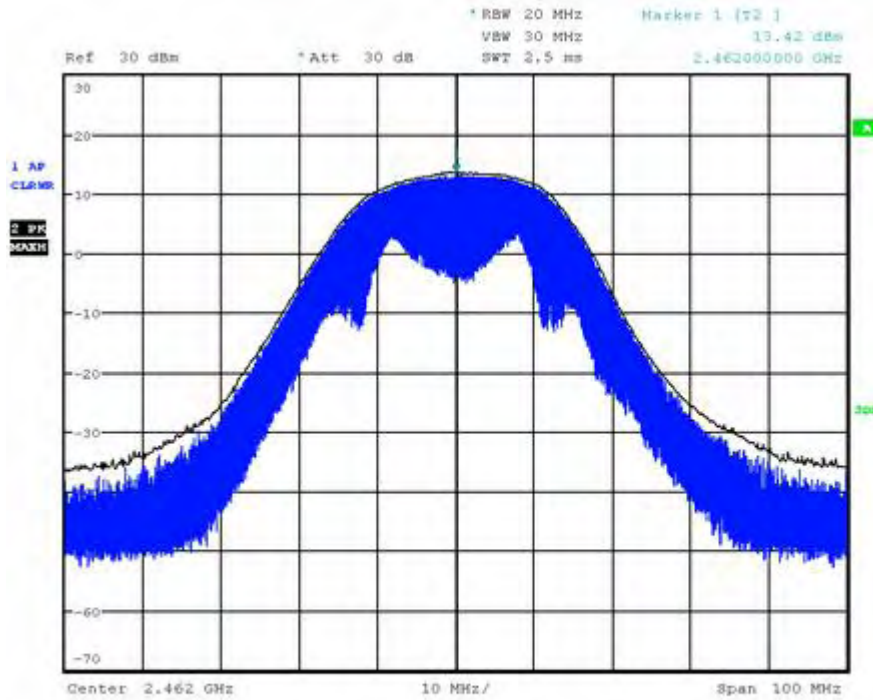

Date: 16.MAY.2011 10:26:48

802.11g, channel 1, 6Mbps

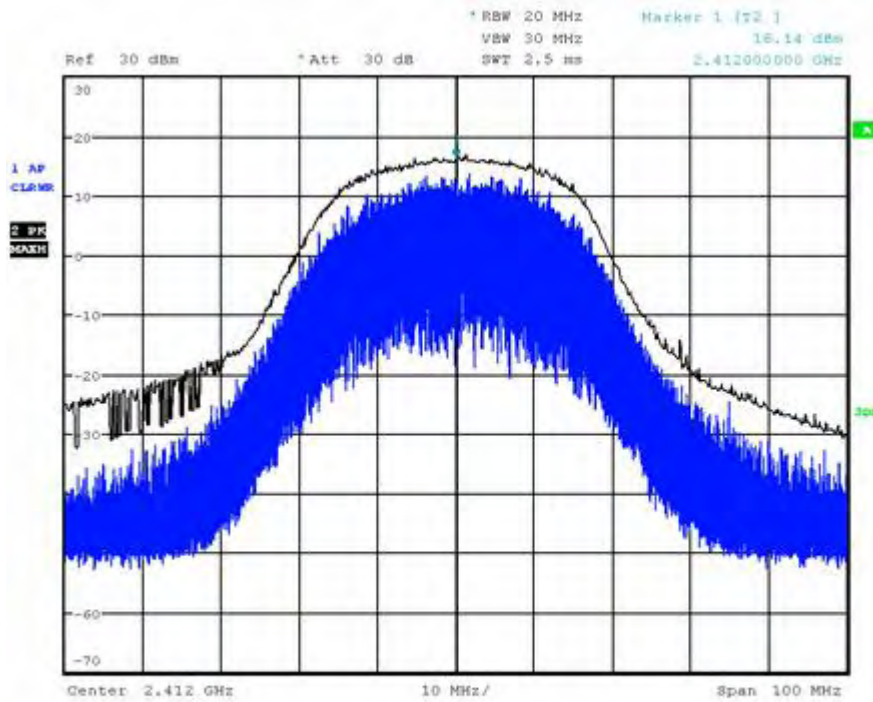

Date: 16.MAY.2011 10:10:49

802.11g, channel 1, 24Mbps

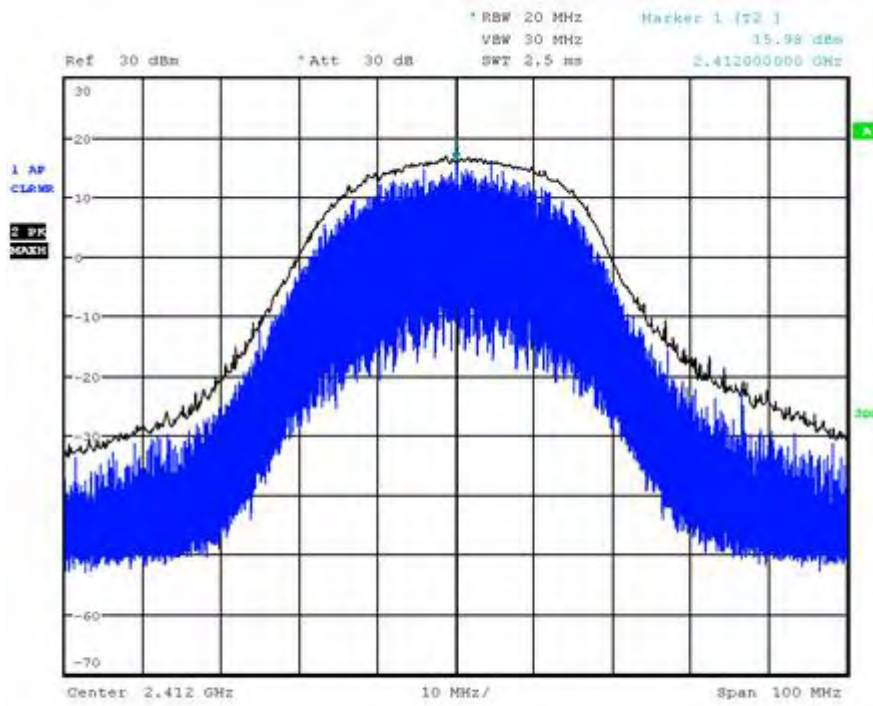

Date: 16.MAY.2011 10:49:35

802.11g, channel 1, 54Mbps

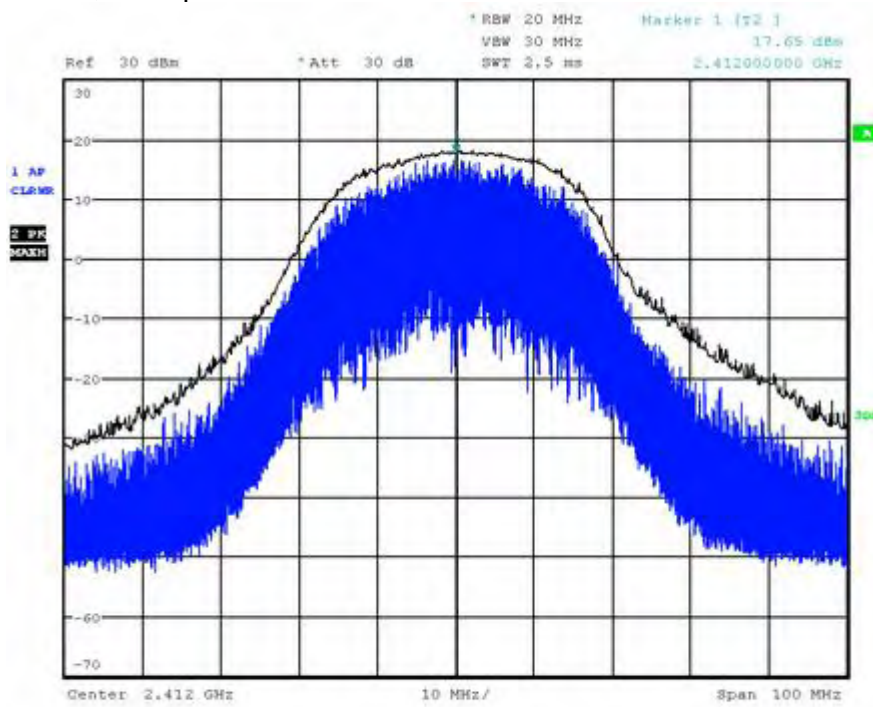

Date: 16.MAY.2011 10:47:15

802.11g, channel 6, 6Mbps

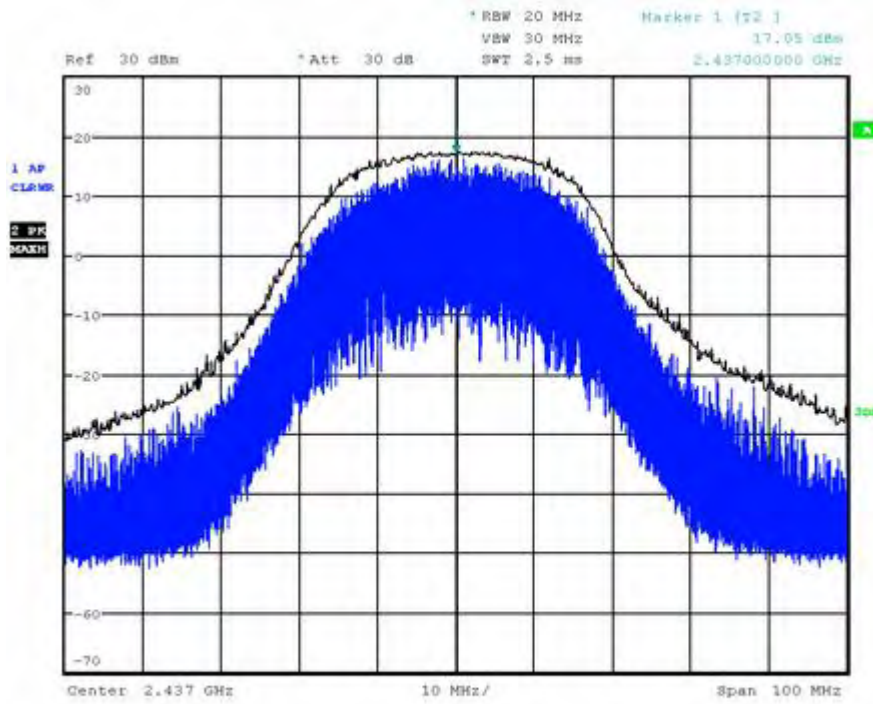

Date: 16.MAY.2011 10:21:41

802.11g, channel 6, 24Mbps

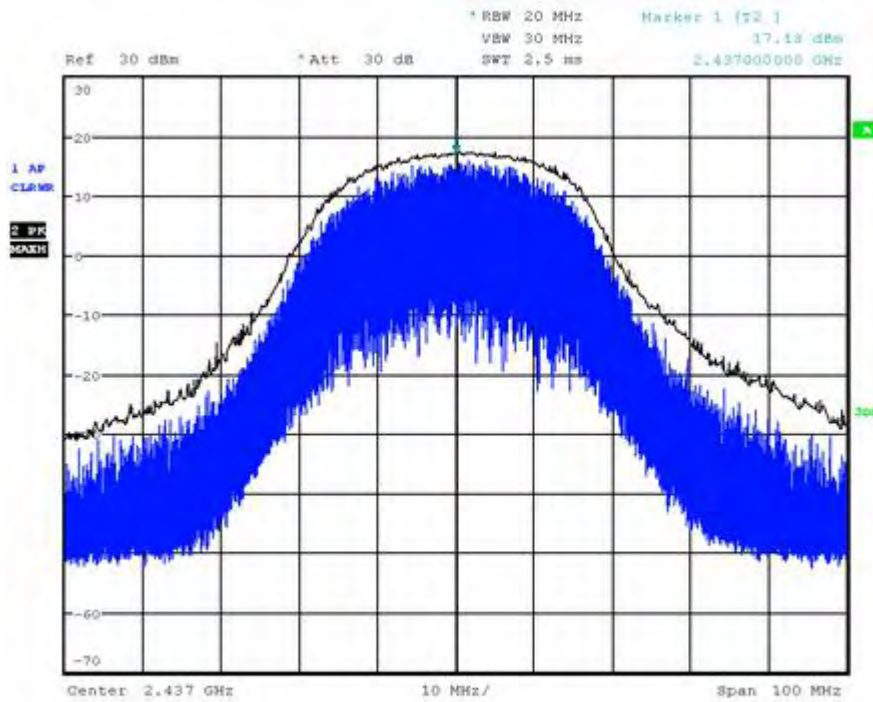

Date: 16.MAY.2011 10:23:39

802.11g, channel 6, 54Mbps

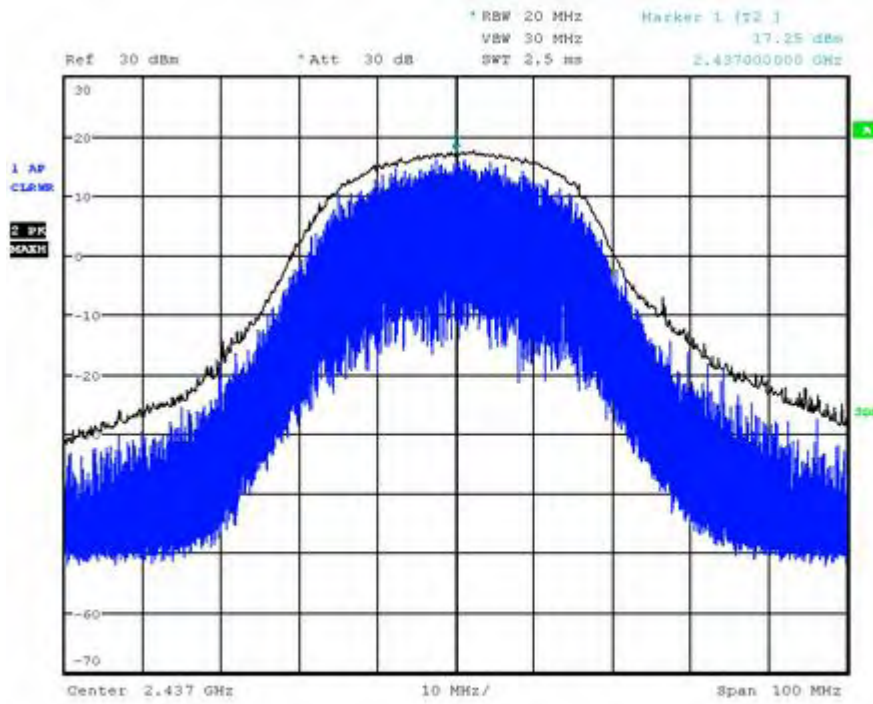

Date: 16.MAY.2011 10:24:16

802.11g, channel 11, 6Mbps

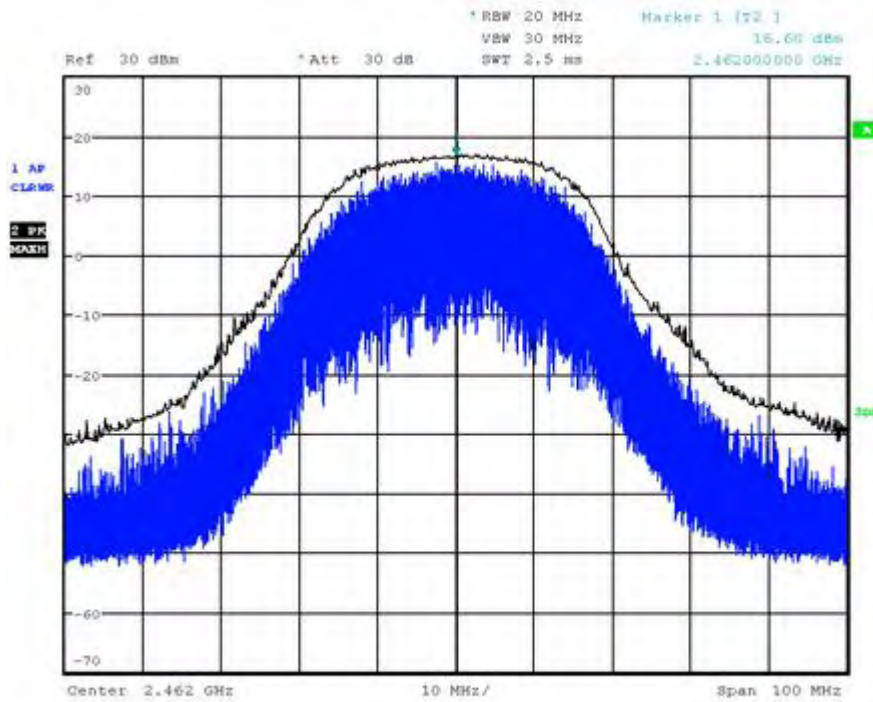

Date: 16.MAY.2011 10:27:51

802.11g, channel 11, 24Mbps

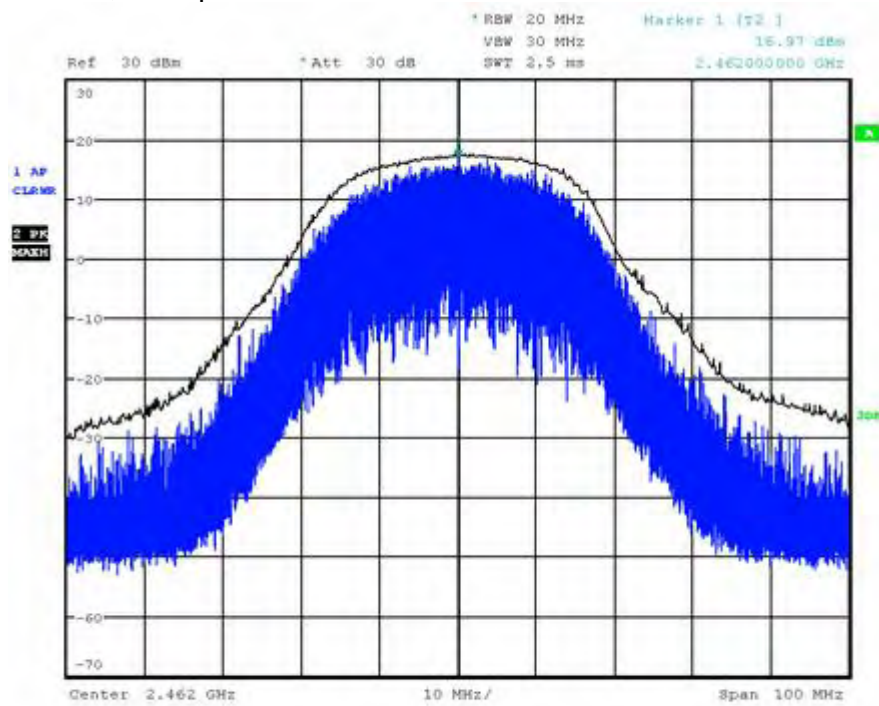

Date: 16.MAY.2011 10:35:53

802.11g, channel 11, 54Mbps

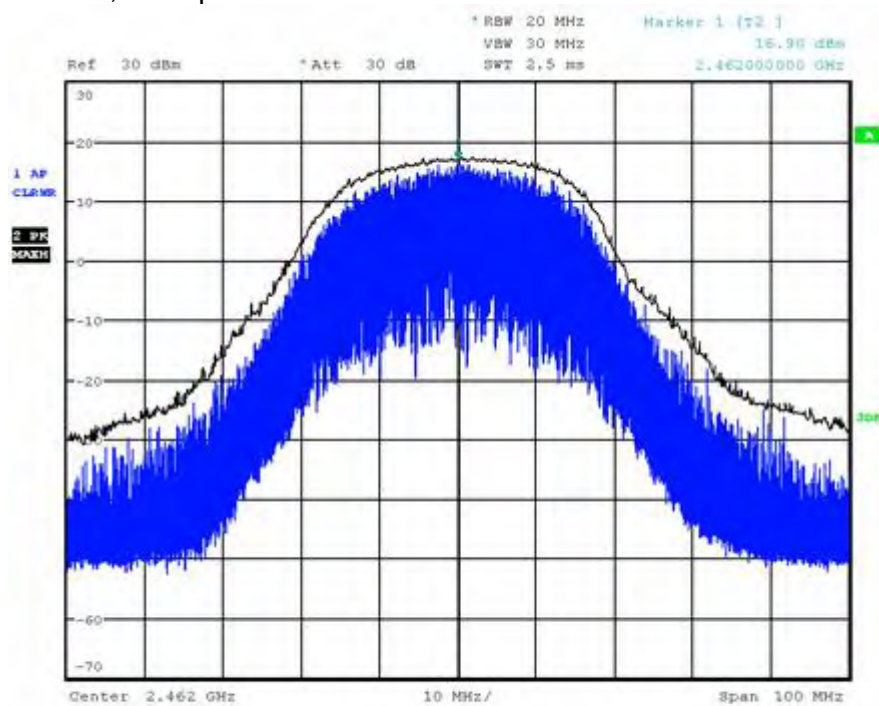

Date: 16.MAY.2011 10:36:37

6. Spurious Emissions (Conduction)

6.1. Test Equipment

The following test equipment are used during the Spurious Emissions (Conduction) test:

Item	Instrument	Manufacturer	Type No./Serial No	Due Date
1	Signal and Spectrum Analyzer	R & S	FSV7/ 101836	2011.12.02
2	10dB Attenuator	Agilent	8493C/ 76156	2011.12.19
3	Spectrum Analyzer	R & S	FSU 26/ 200932	2011.12.05

6.2. Test Setup

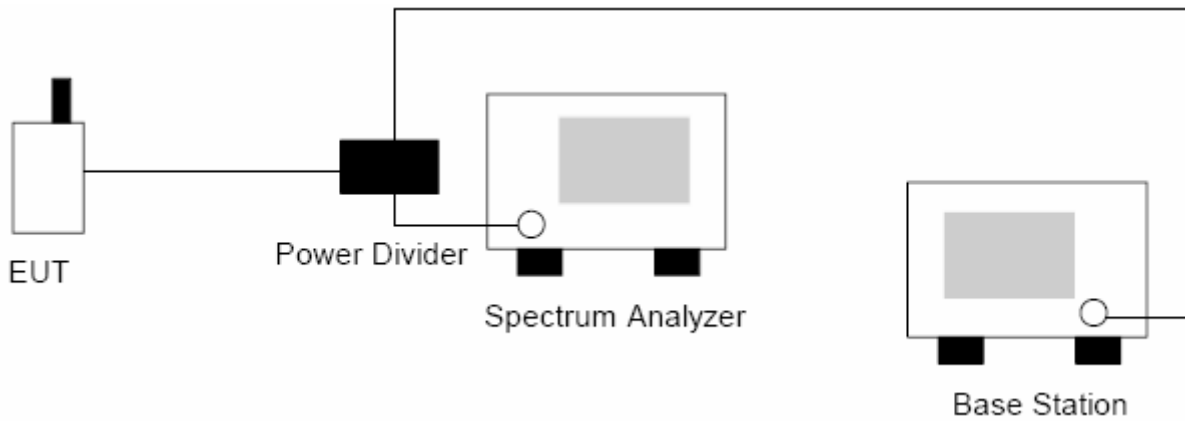

6.3. Limits

Limits	< (P-20dB)
Note: P is the highest level of the desired power ;	

6.4. Test Procedure

Spurious RF Conducted Emissions:

The EUT was connected to Spectrum Analyzer and Base Station via power divider. Use the following spectrum analyzer settings:

Span = wide enough to capture the peak level of the in-band emission and all spurious emissions (e.g., harmonics) from the lowest frequency generated in the EUT up through the 10th harmonic. Typically, several plots are required to cover this entire span.

RBW = 100 kHz; VBW \geq RBW; Sweep = auto; Detector function = peak; Trace = max hold

Allow the trace to stabilize. Set the marker on the peak of any spurious emission recorded. The level displayed must comply with the limit specified in this Section.

6.5. Test Specification

According to CFR 47 FCC Part 15.247

6.6. EUT Operation

See chapter 1.2 of this test report

6.7. Test Result

channel	mode	Data Rate (Mbps)	Measured level (dBc)	Limit (dBc)	Result
1	802.11b	1	Refer to picture	<-20	Pass
		5.5	Refer to picture	<-20	Pass
		11	Refer to picture	<-20	Pass
	802.11g	6	Refer to picture	<-20	Pass
		24	Refer to picture	<-20	Pass
		54	Refer to picture	<-20	Pass
6	802.11b	1	Refer to picture	<-20	Pass
		5.5	Refer to picture	<-20	Pass
		11	Refer to picture	<-20	Pass
	802.11g	6	Refer to picture	<-20	Pass
		24	Refer to picture	<-20	Pass
		54	Refer to picture	<-20	Pass
11	802.11b	1	Refer to picture	<-20	Pass
		5.5	Refer to picture	<-20	Pass
		11	Refer to picture	<-20	Pass
	802.11g	6	Refer to picture	<-20	Pass
		24	Refer to picture	<-20	Pass
		54	Refer to picture	<-20	Pass

802.11b, channel 1, 1 Mbps
9kHz~30MHz

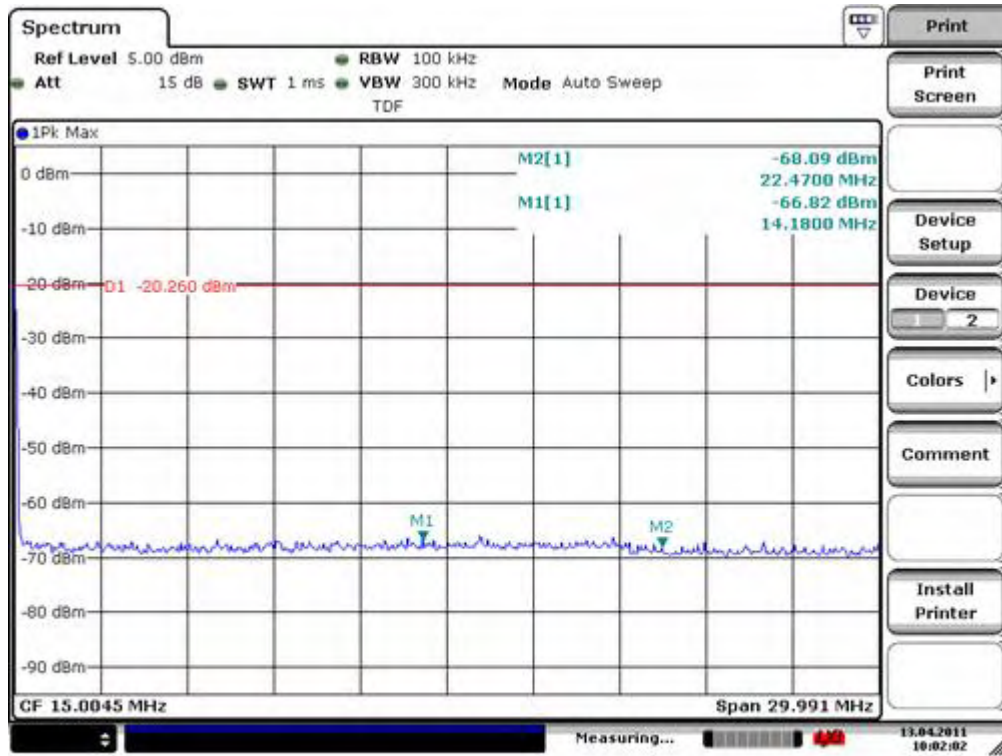

CH1 B 1M
Date: 13.APR.2011 10:02:01

30MHz~25GHz

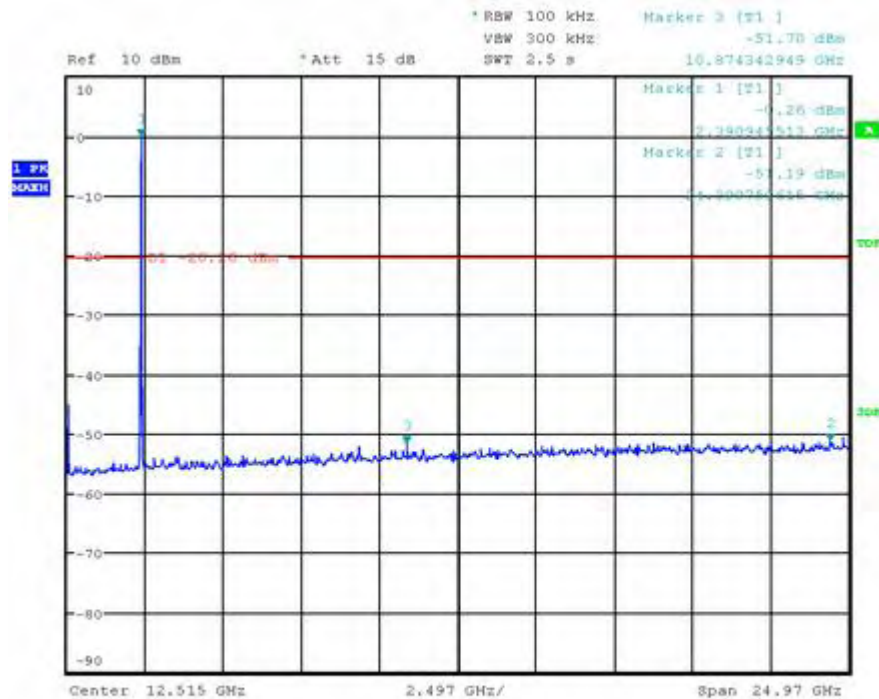

Date: 13.APR.2011 04:09:54

Note: The signal beyond the limit is carrier

802.11b, channel 1, 5.5 Mbps
9kHz~30MHz

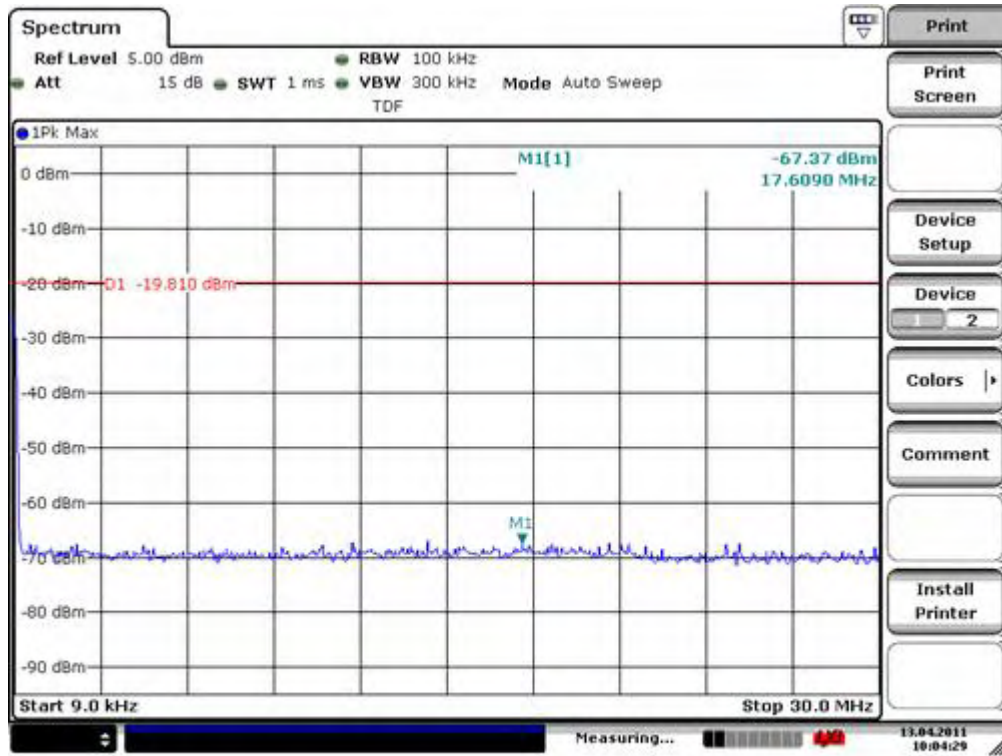

CH1 B 1M
 Date: 13.APR.2011 10:04:28

30MHz~25GHz

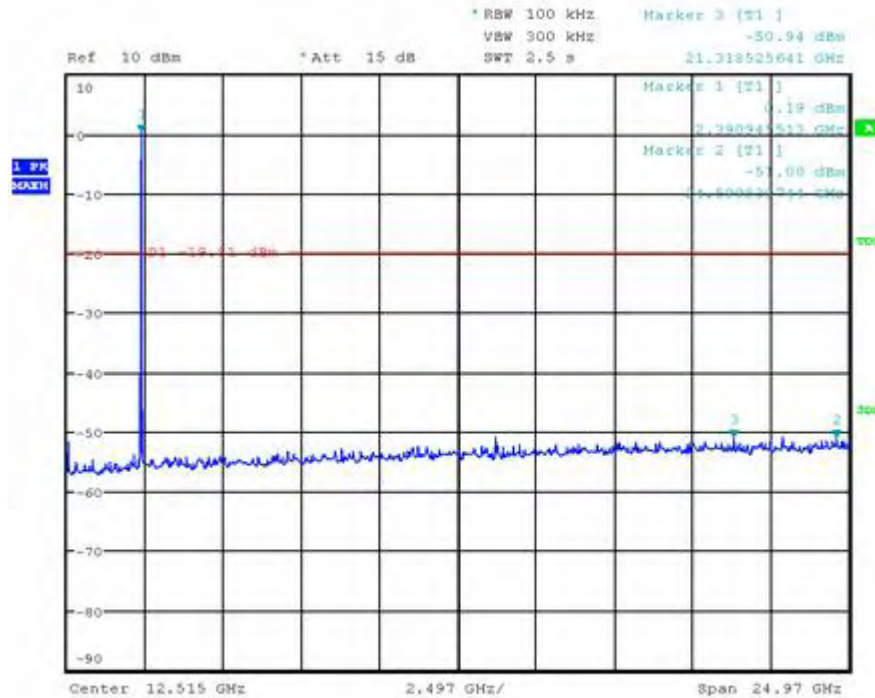

Date: 13.APR.2011 04:11:34

Note: The signal beyond the limit is carrier

802.11b, channel 1, 11 Mbps
9kHz~30MHz

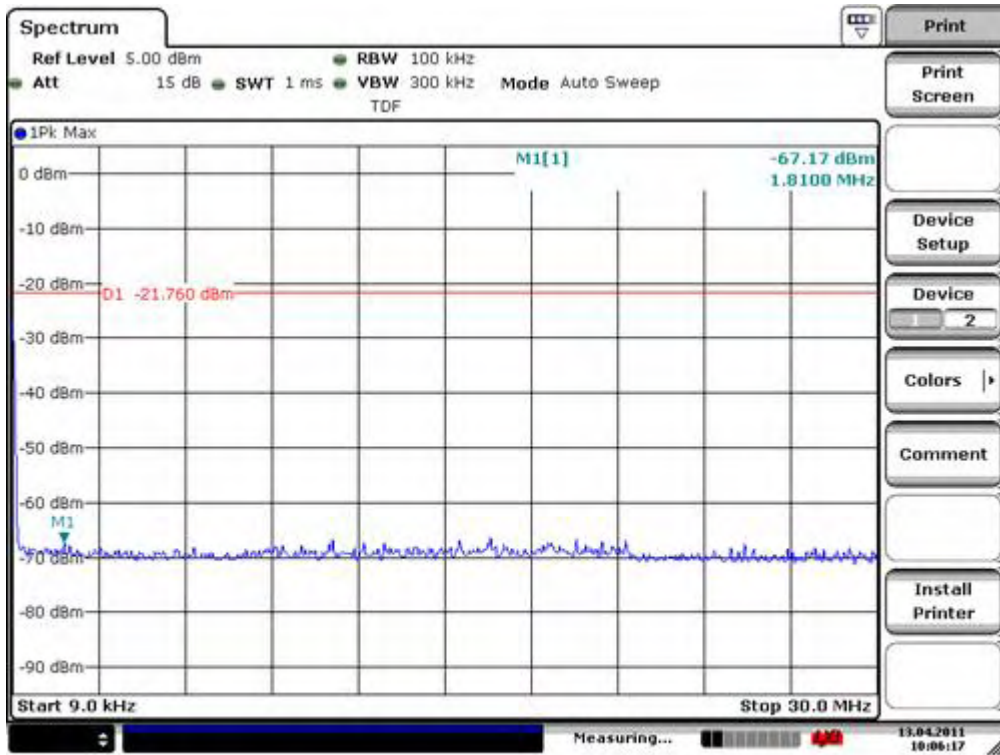

CH1 B 1M
 Date: 13.APR.2011 10:06:16

30MHz~25GHz

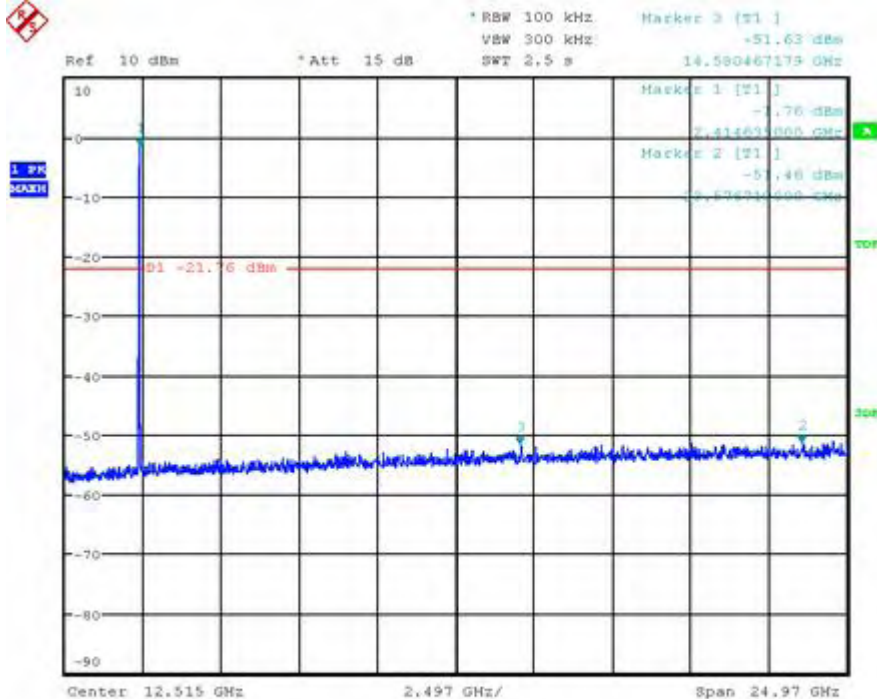

Date: 12.APR.2011 09:42:37

Note: The signal beyond the limit is carrier

802.11b, channel 6, 1 Mbps
9kHz~30MHz

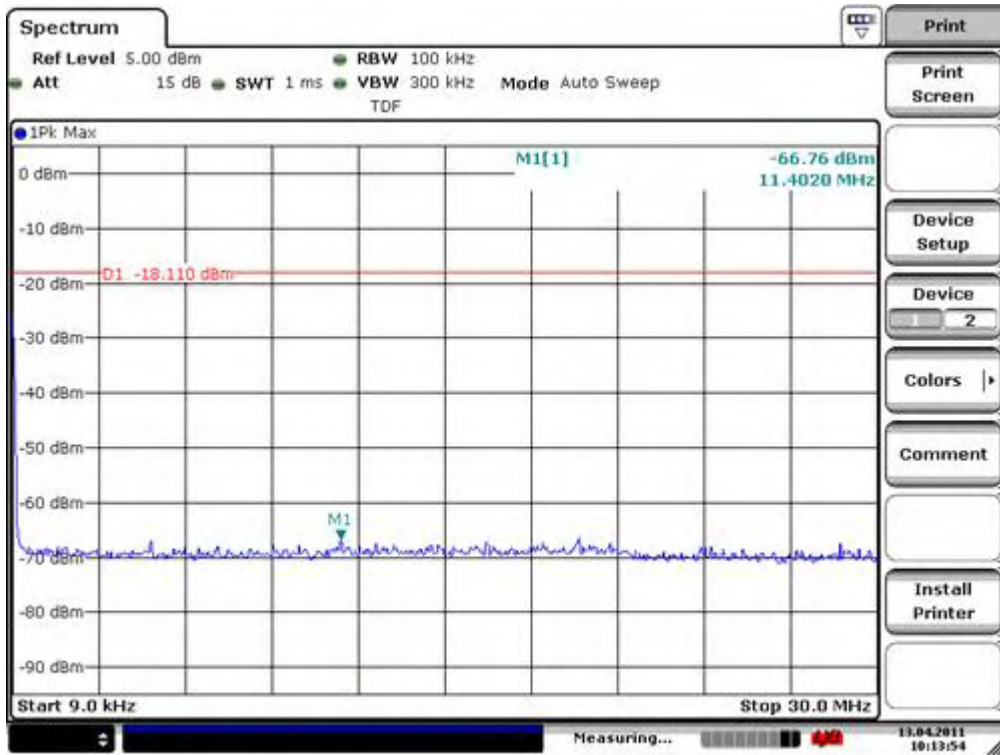

CH1 B 1M
 Date: 13.APR.2011 10:13:53

30MHz~25GHz

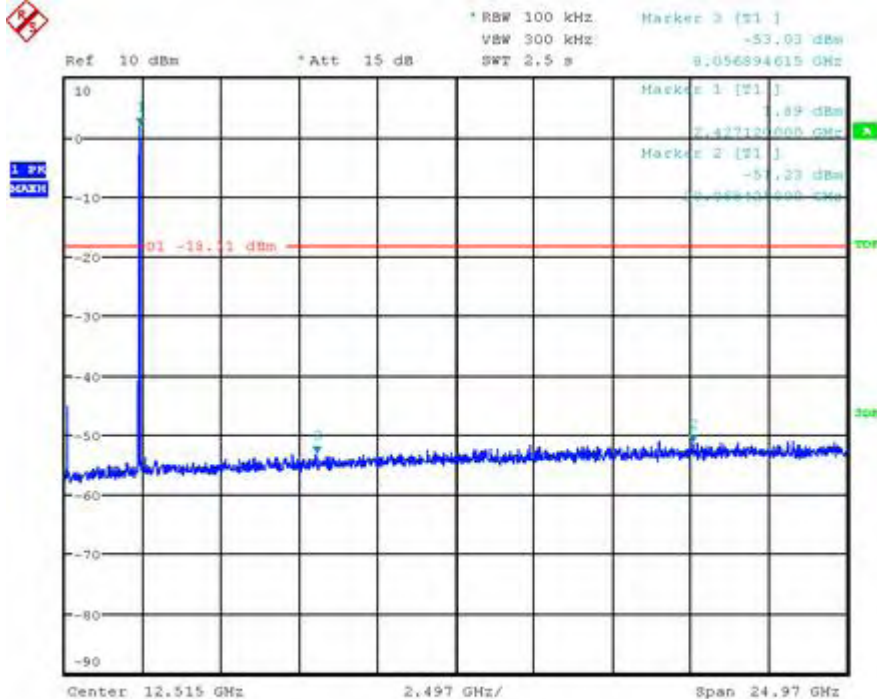

Date: 12.APR.2011 09:47:41

Note: The signal beyond the limit is carrier

802.11b, channel 6, 5.5 Mbps
9kHz~30MHz

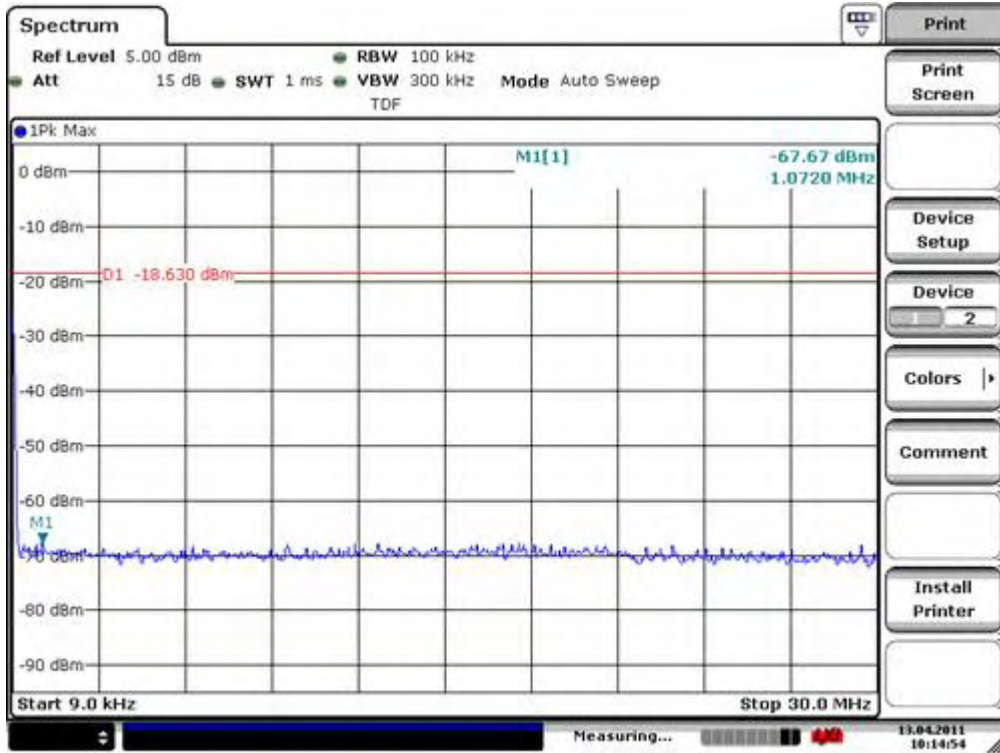

CH1 B 1M
 Date: 13.APR.2011 10:14:54

30MHz~25GHz

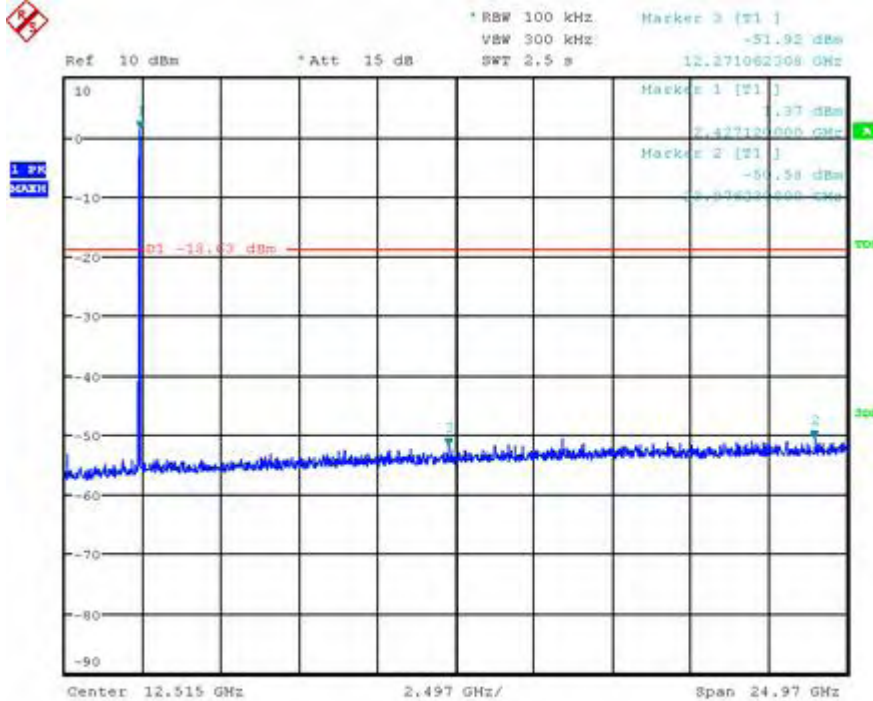

Date: 12.APR.2011 09:57:07

Note: The signal beyond the limit is carrier

802.11b, channel 6, 11 Mbps
9kHz~30MHz

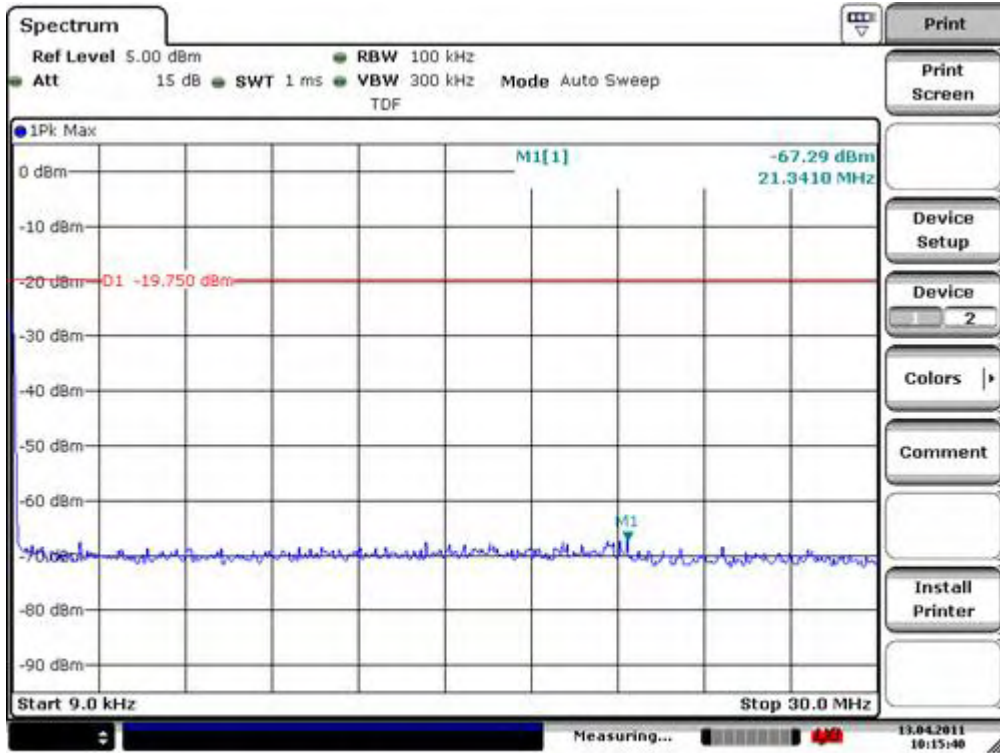

CH1 B 1M
 Date: 13.APR.2011 10:15:39

30MHz~25GHz

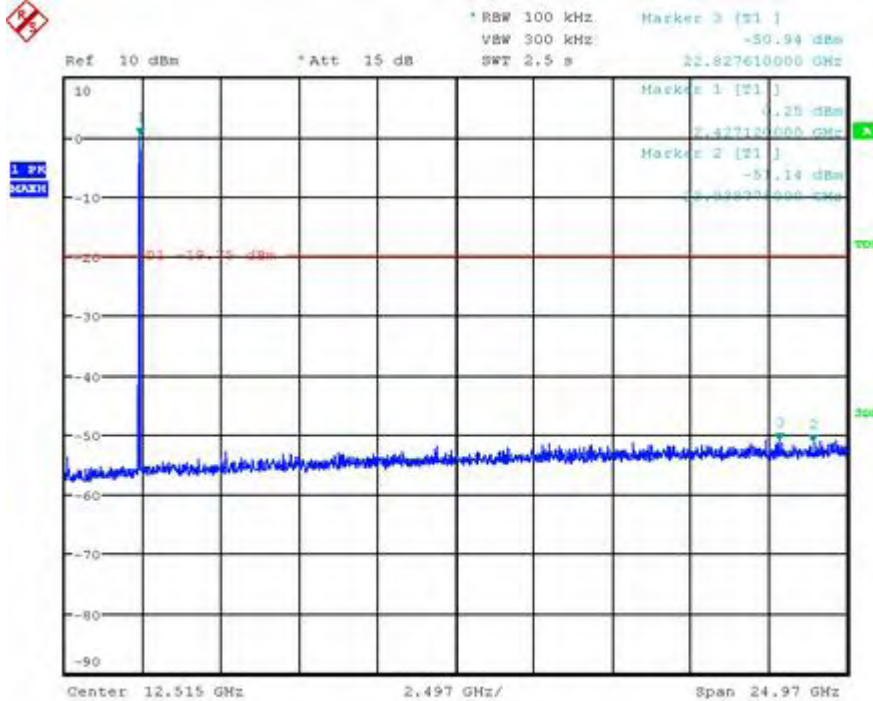

Date: 12.APR.2011 10:30:12

Note: The signal beyond the limit is carrier

802.11b, channel 11, 1 Mbps
9kHz~30MHz

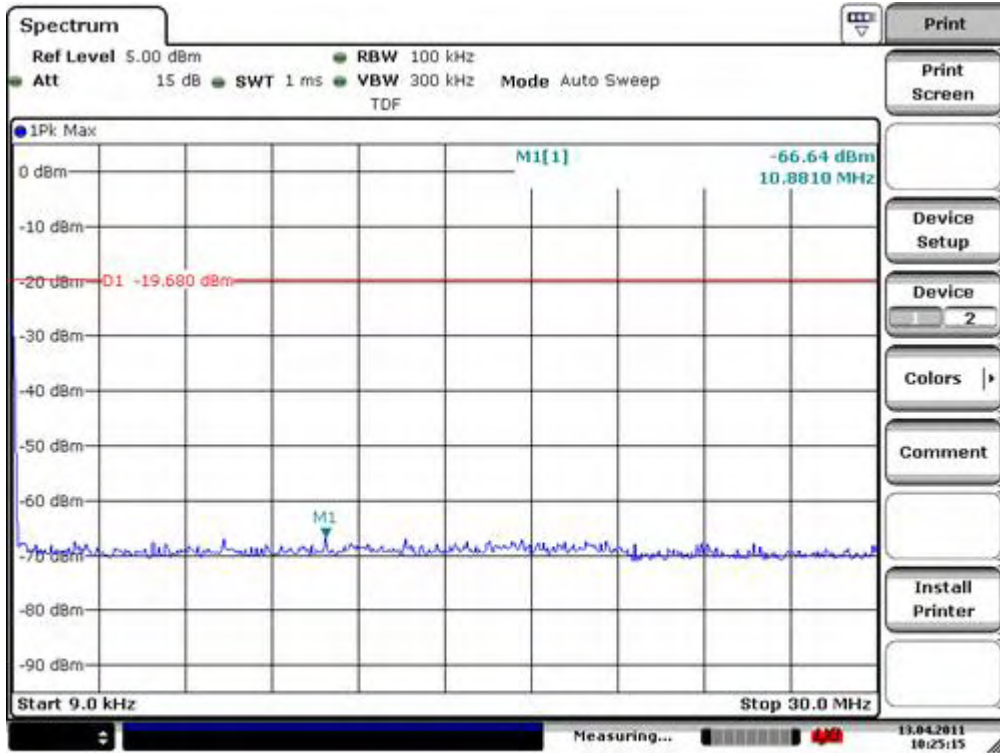

CH1 B 1M
 Date: 13.APR.2011 10:25:14

30MHz~25GHz

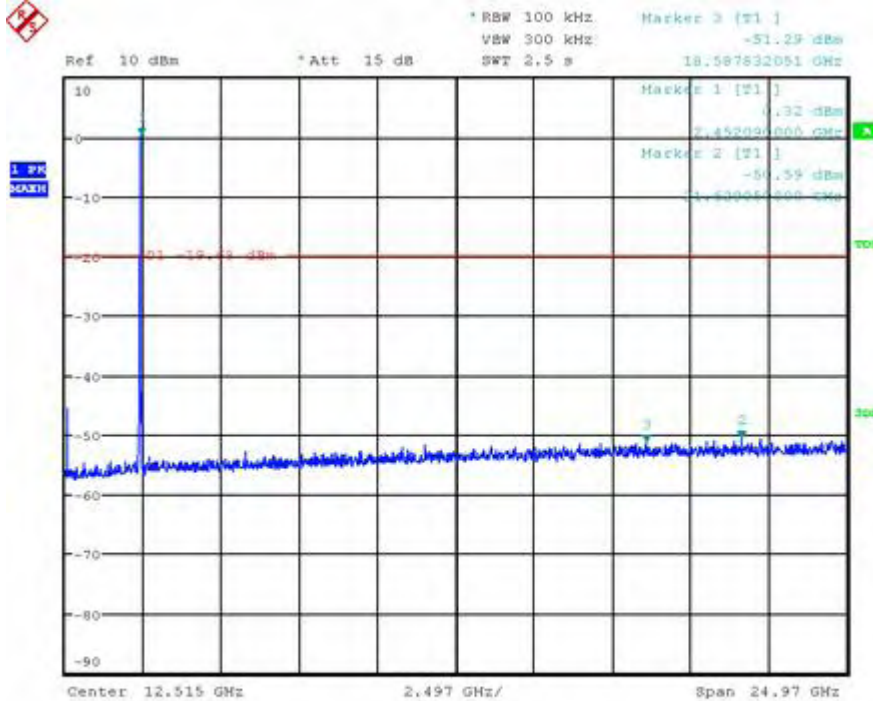

Date: 12.APR.2011 10:10:39

Note: The signal beyond the limit is carrier

802.11b, channel 11, 5.5Mbps
9kHz~30MHz

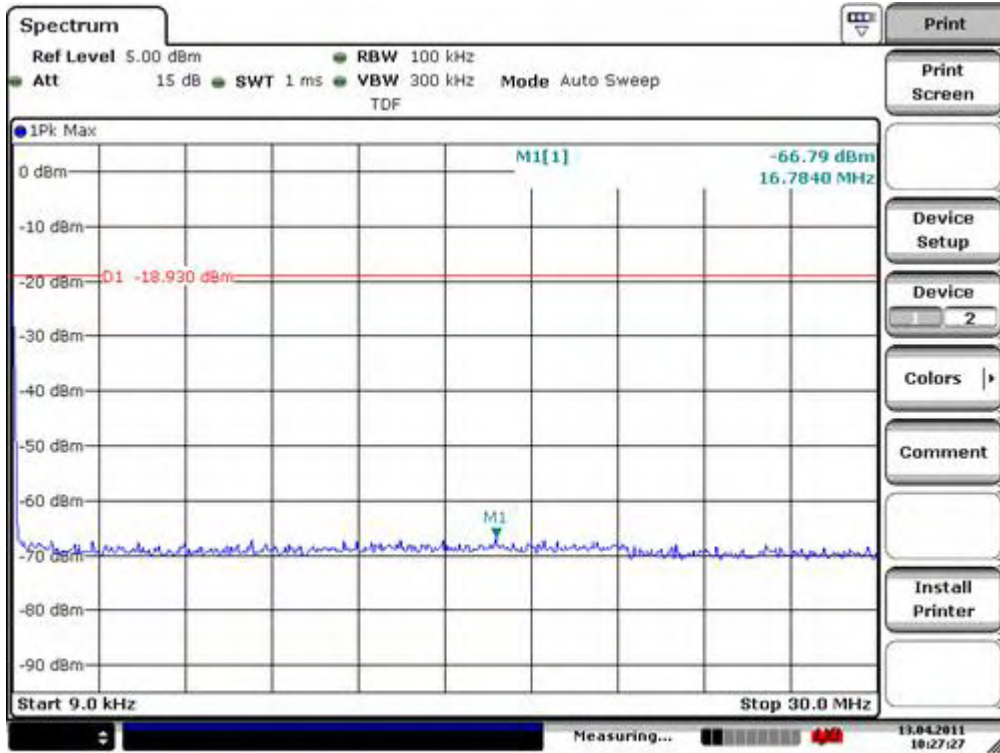

CH1 B 1M
 Date: 13.APR.2011 10:27:26

30MHz~25GHz

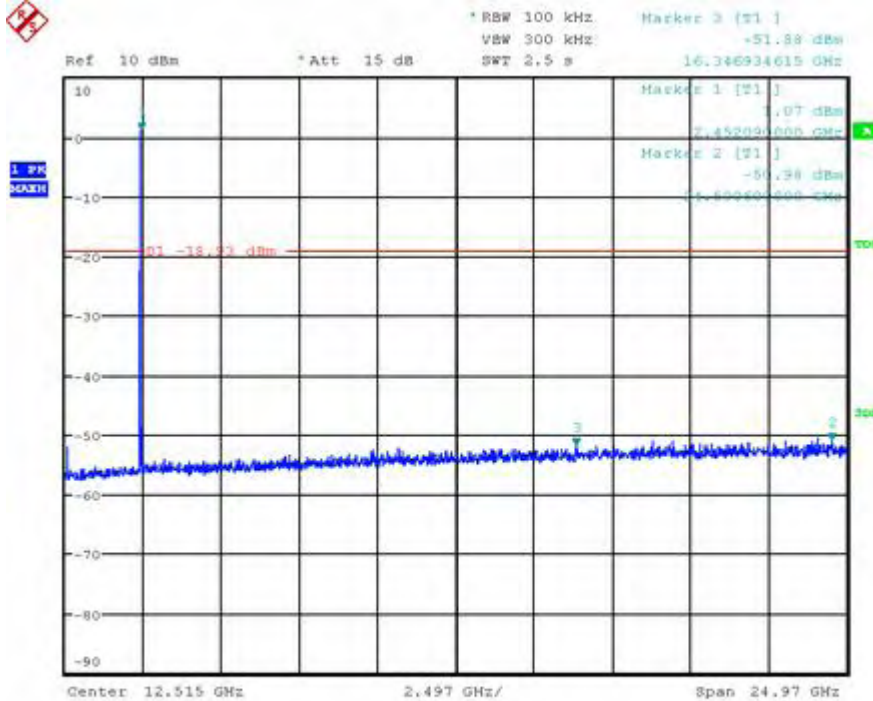

Date: 12.APR.2011 10:13:11

Note: The signal beyond the limit is carrier

802.11b, channel 11, 11Mbps
9kHz~30MHz

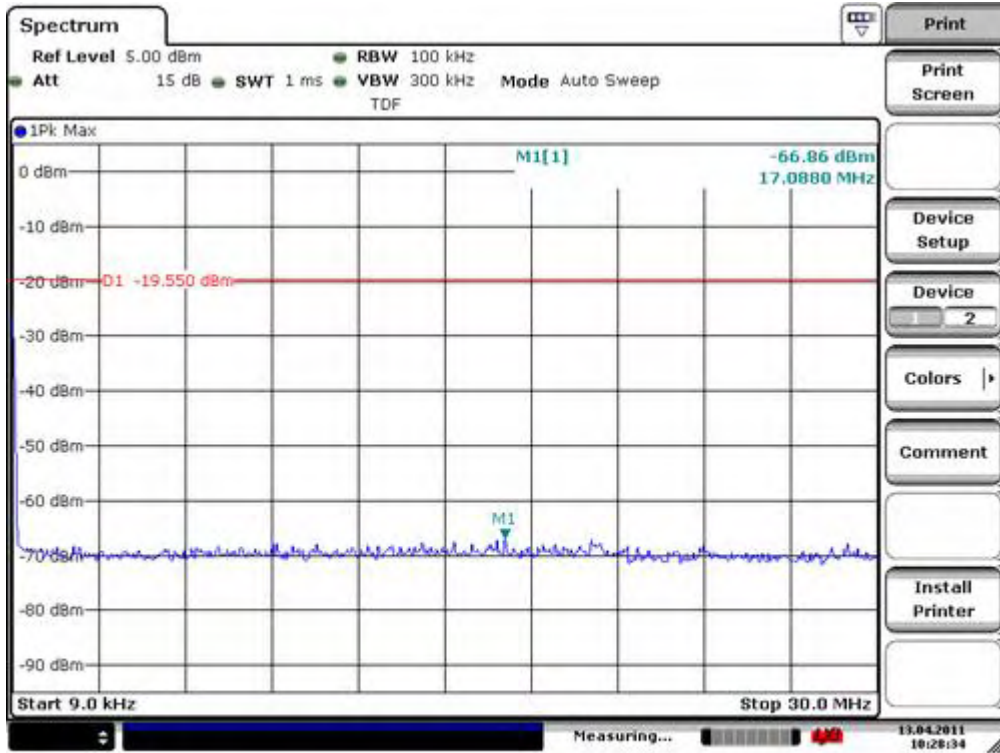

CH1 B 1M
 Date: 13.APR.2011 10:28:33

30MHz~25GHz

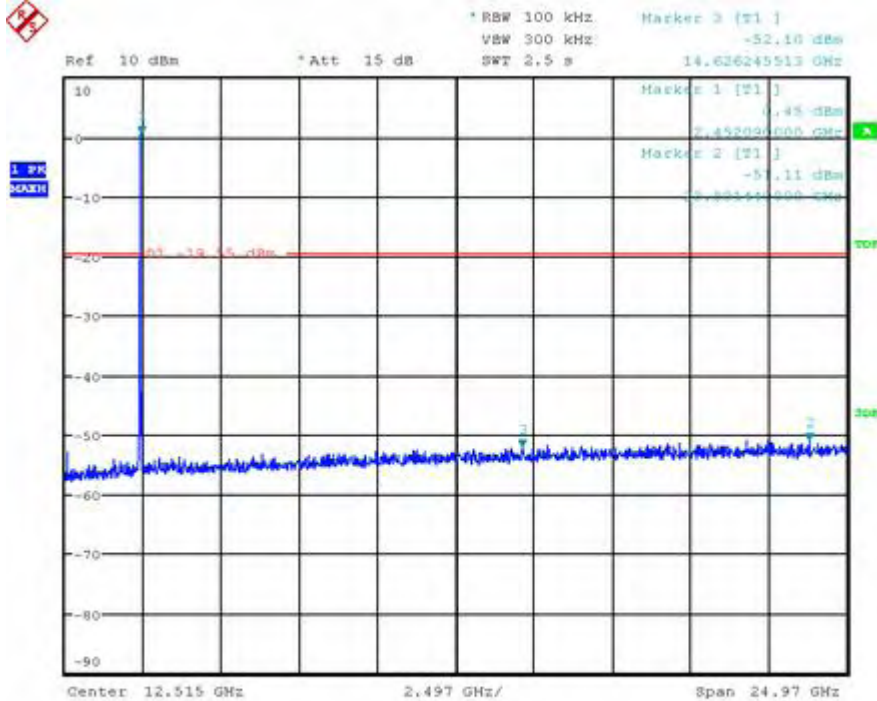

Date: 12.APR.2011 10:15:57

Note: The signal beyond the limit is carrier

802.11g, channel 1, 6Mbps
9kHz~30MHz

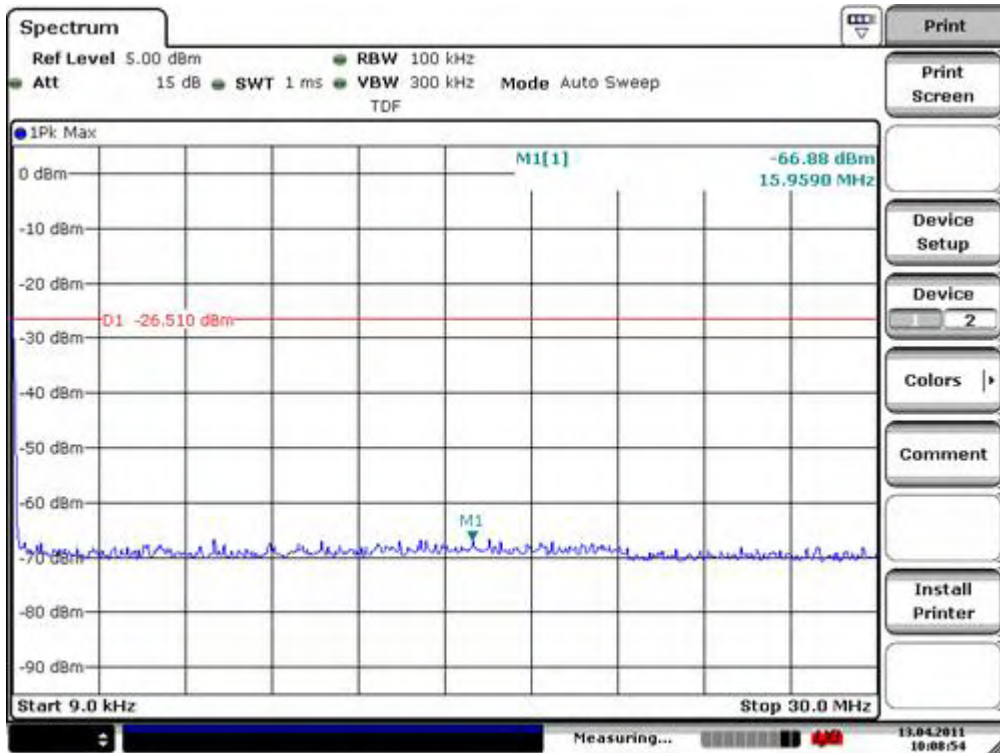

CH1 B 1M
 Date: 13.APR.2011 10:08:53

30MHz~25GHz

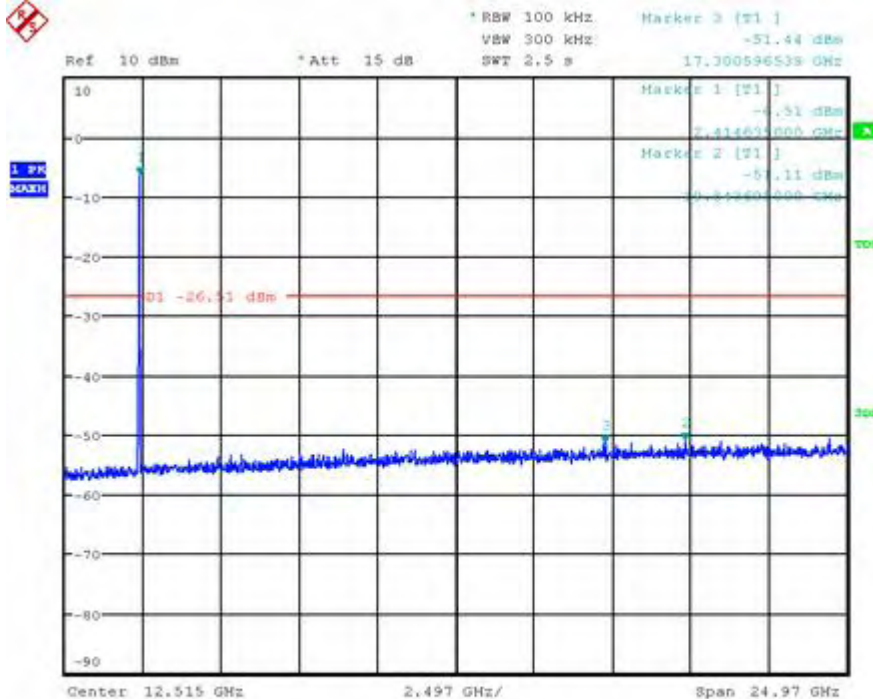

Date: 12.APR.2011 09:45:07

Note: The signal beyond the limit is carrier

802.11g, channel 1, 24Mbps
9kHz~30MHz

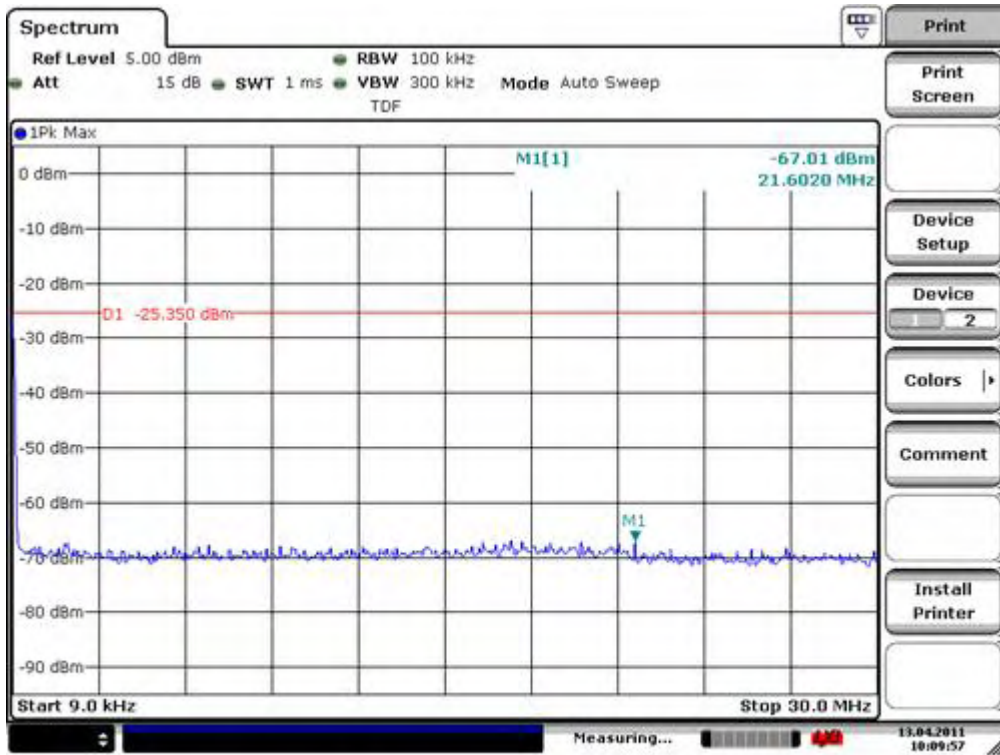

CH1 B 1M
 Date: 13.APR.2011 10:09:56

30MHz~25GHz

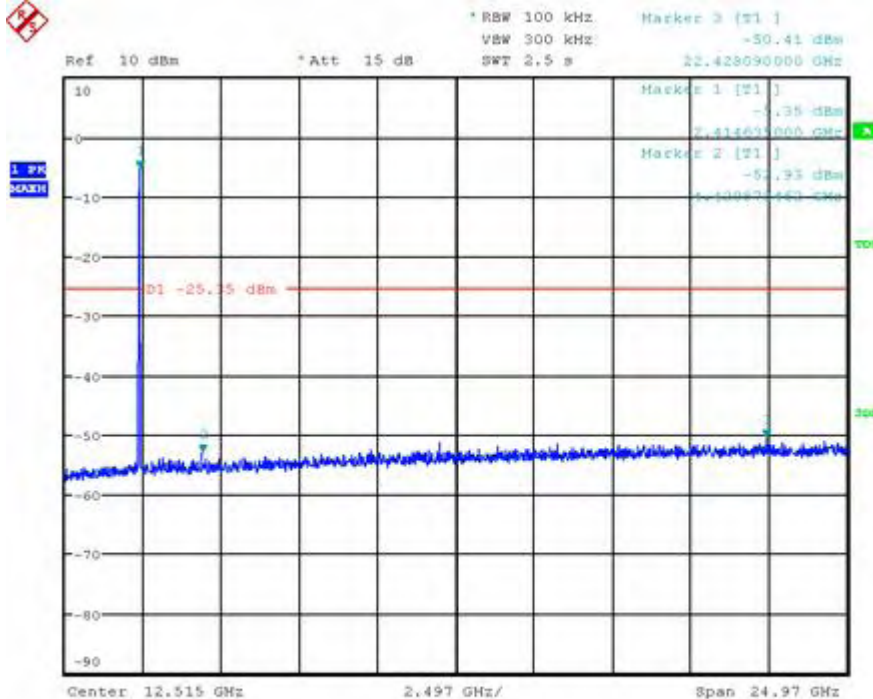

Date: 12.APR.2011 09:33:52

Note: The signal beyond the limit is carrier

802.11g, channel 1, 54Mbps
9kHz~30MHz

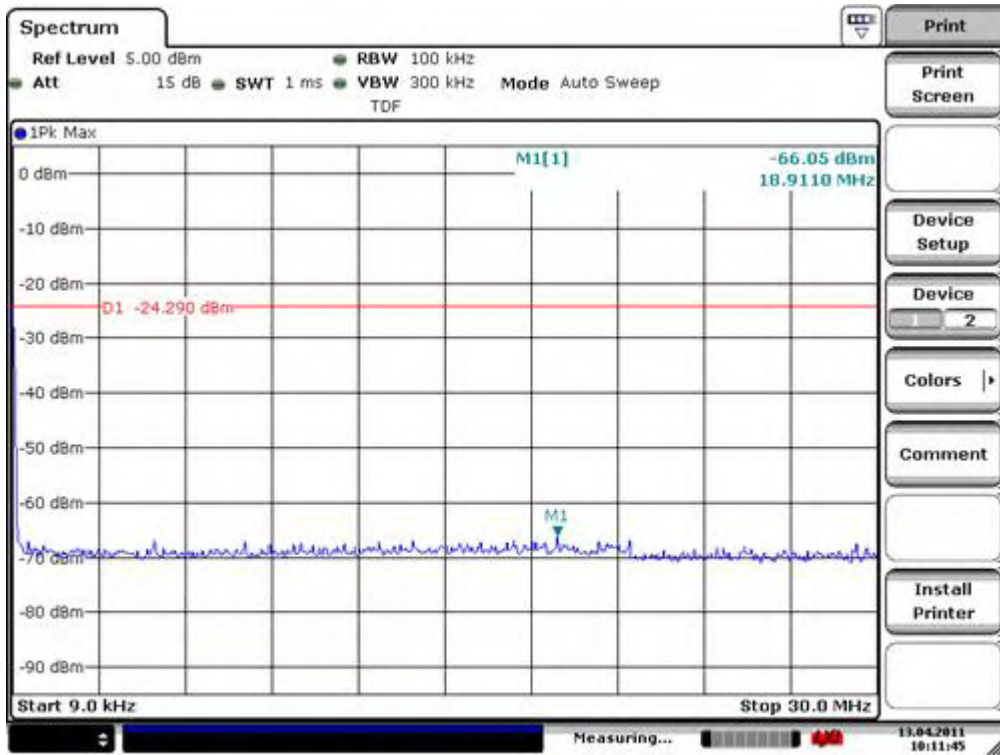

CH1 B 1M
 Date: 13.APR.2011 10:11:45

30MHz~25GHz

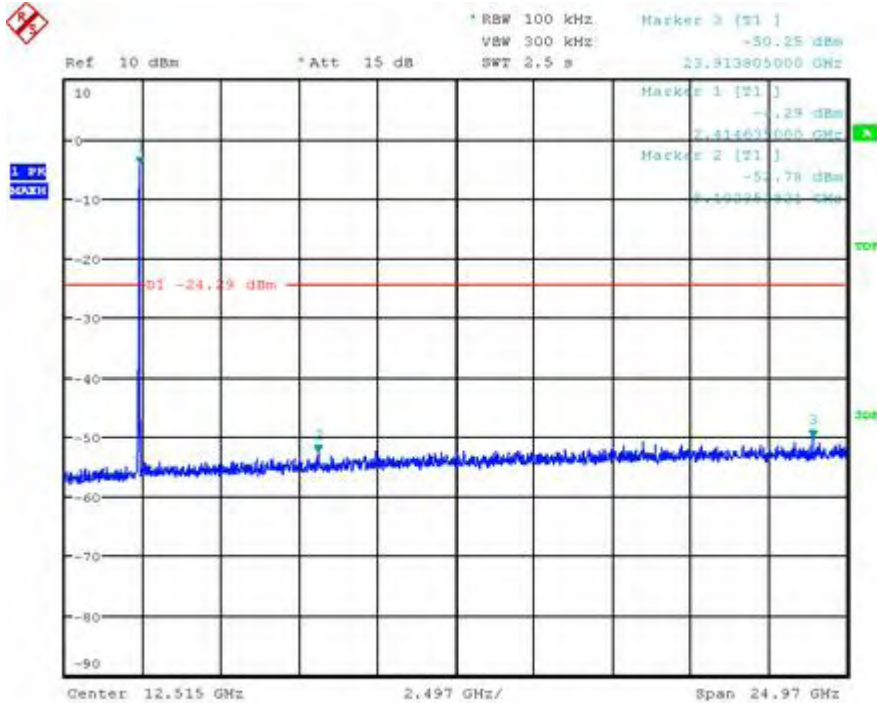

Date: 12.APR.2011 09:35:47

Note: The signal beyond the limit is carrier

802.11g, channel 6, 6Mbps
9kHz~30MHz

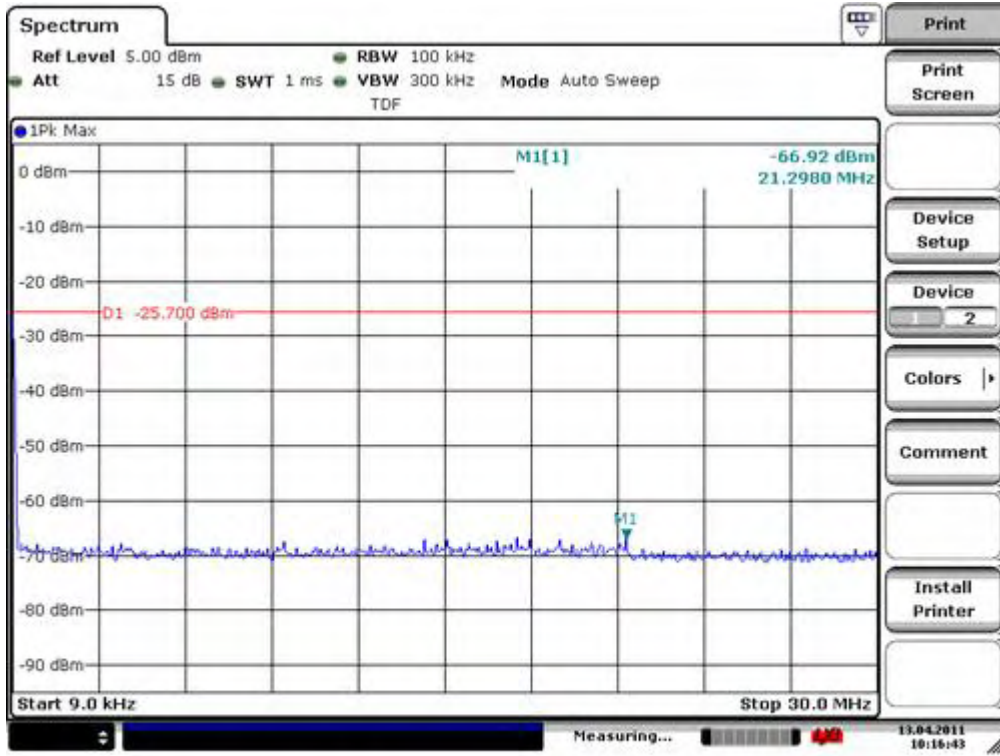

CHI B 1M
 Date: 13.APR.2011 10:16:42

30MHz~25GHz

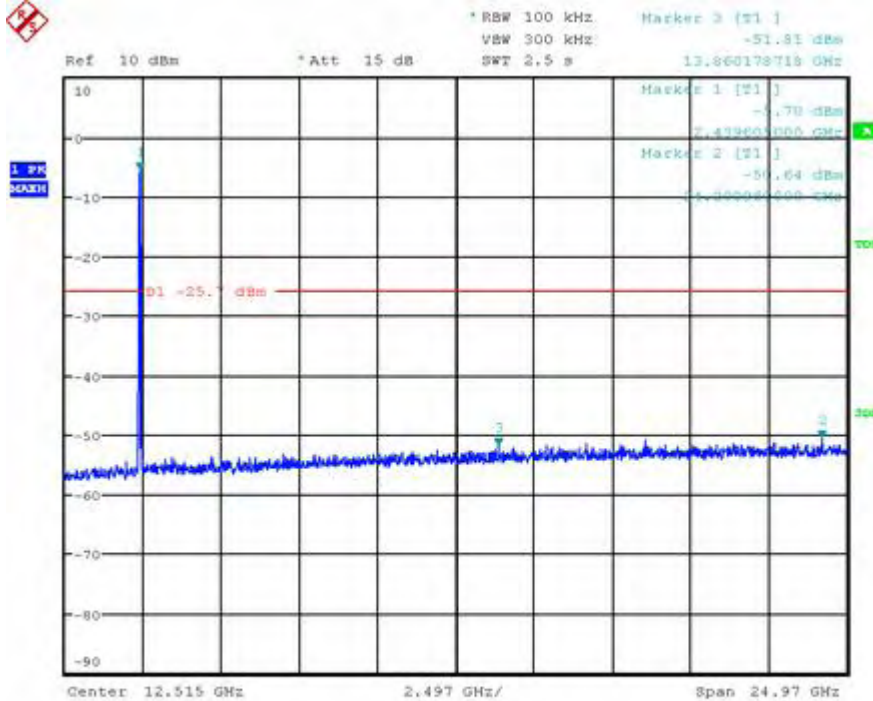

Date: 12.APR.2011 10:00:48

Note: The signal beyond the limit is carrier

802.11g, channel 6, 24Mbps
9kHz~30MHz

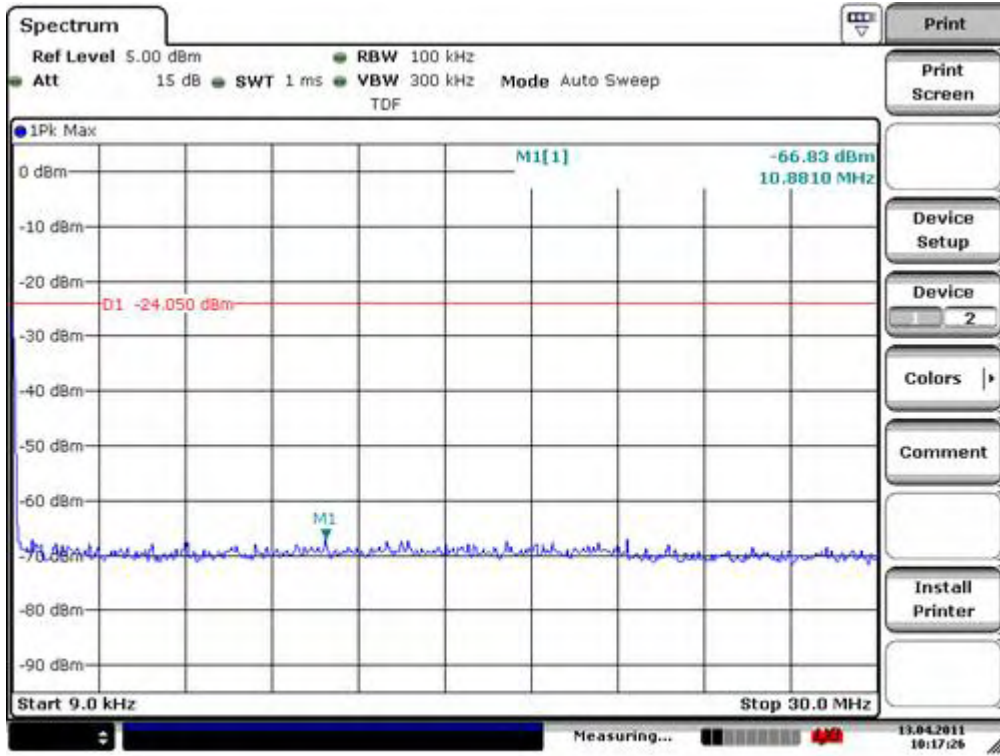

CH1 B 1M
 Date: 13.APR.2011 10:17:26

30MHz~25GHz

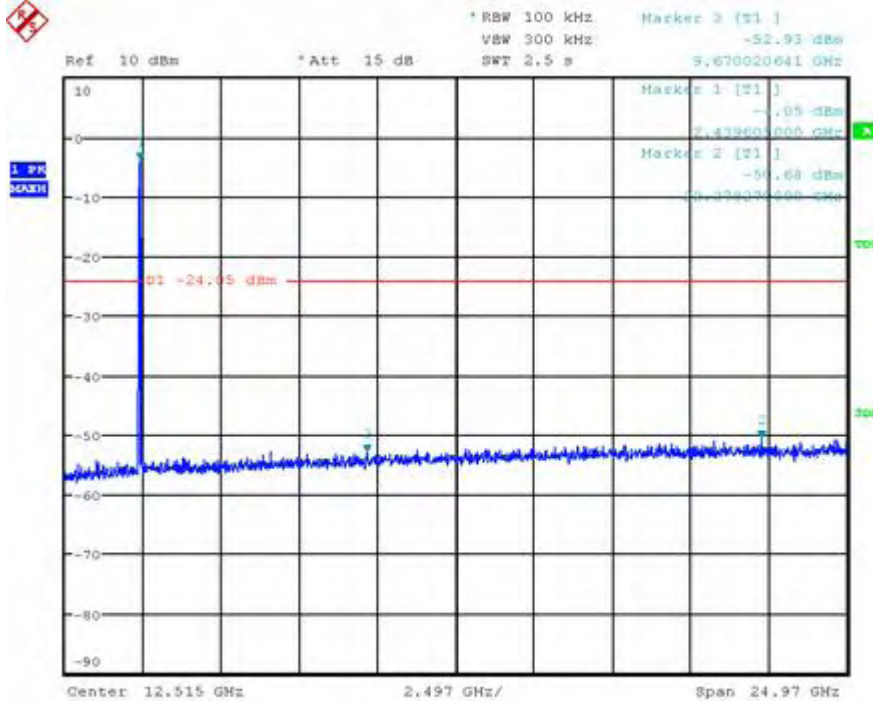

Date: 12.APR.2011 10:04:00

Note: The signal beyond the limit is carrier

802.11g, channel 6, 54Mbps
9kHz~30MHz

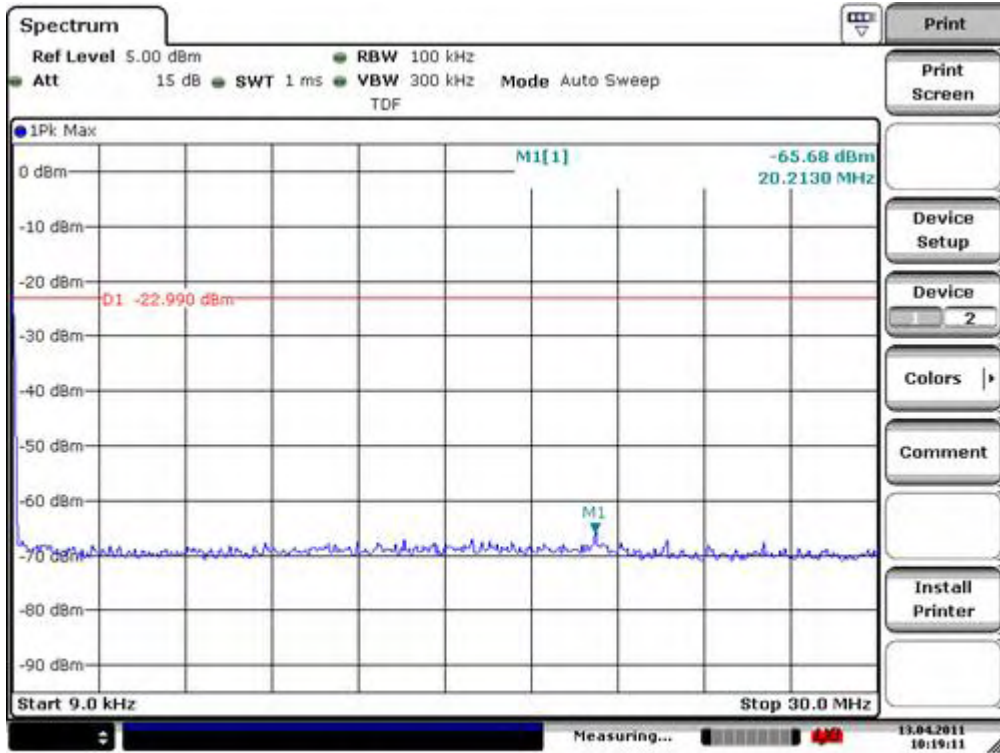

CH1 B 1M
 Date: 13.APR.2011 10:19:11

30MHz~25GHz

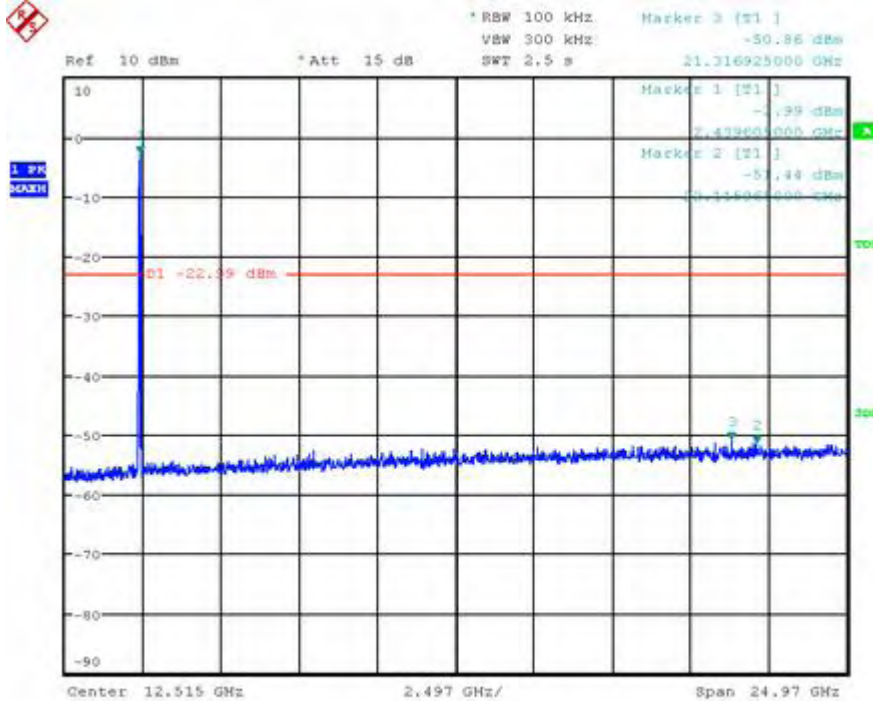

Date: 12.APR.2011 10:28:22

Note: The signal beyond the limit is carrier

802.11g, channel 11, 6Mbps
9kHz~30MHz

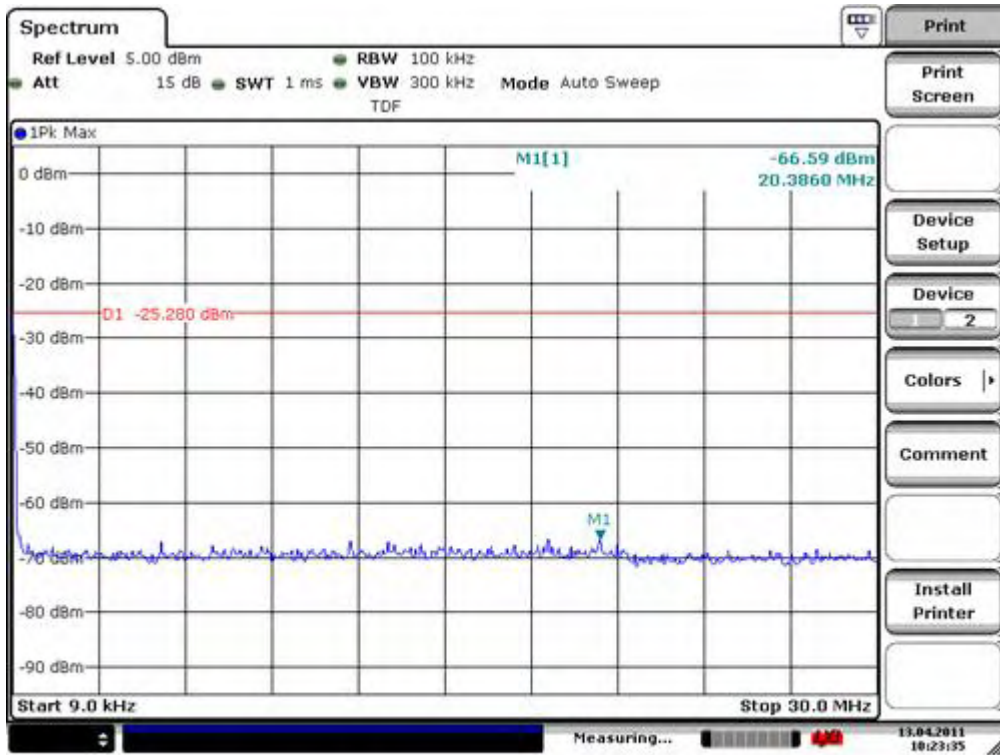

CH1 B 1M
 Date: 13.APR.2011 10:23:35

30MHz~25GHz

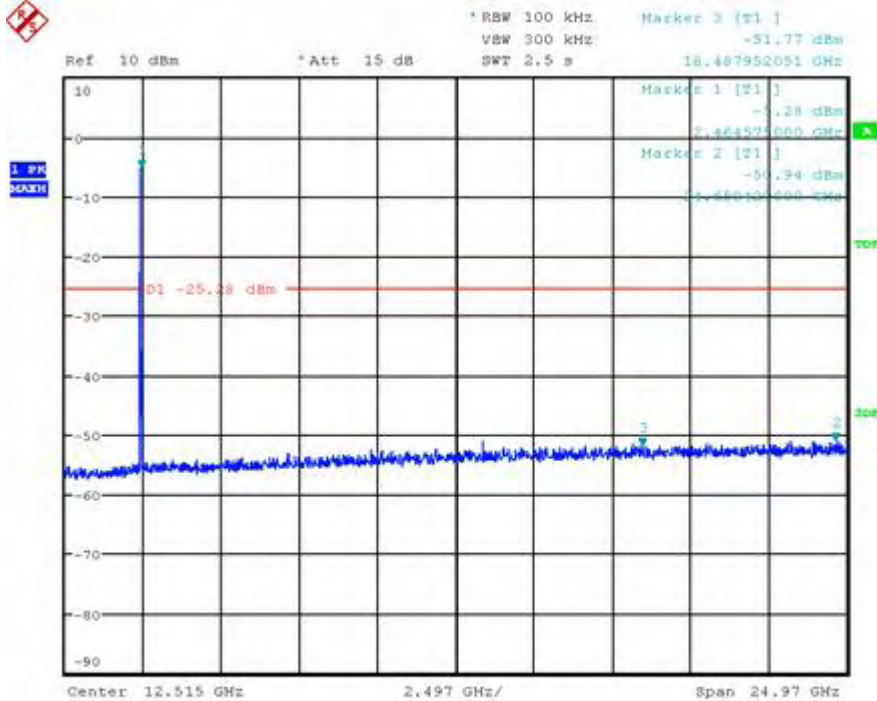

Date: 12.APR.2011 10:19:22

Note: The signal beyond the limit is carrier

802.11g, channel 11, 24Mbps
9kHz~30MHz

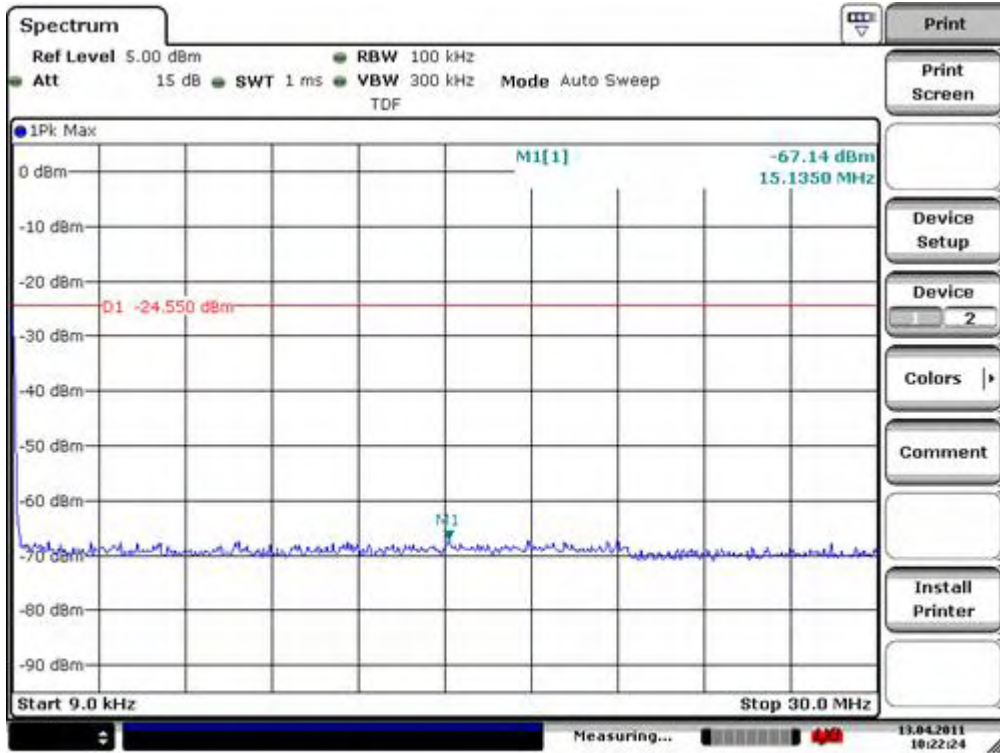

CH1 B 1M
 Date: 13.APR.2011 10:22:23

30MHz~25GHz

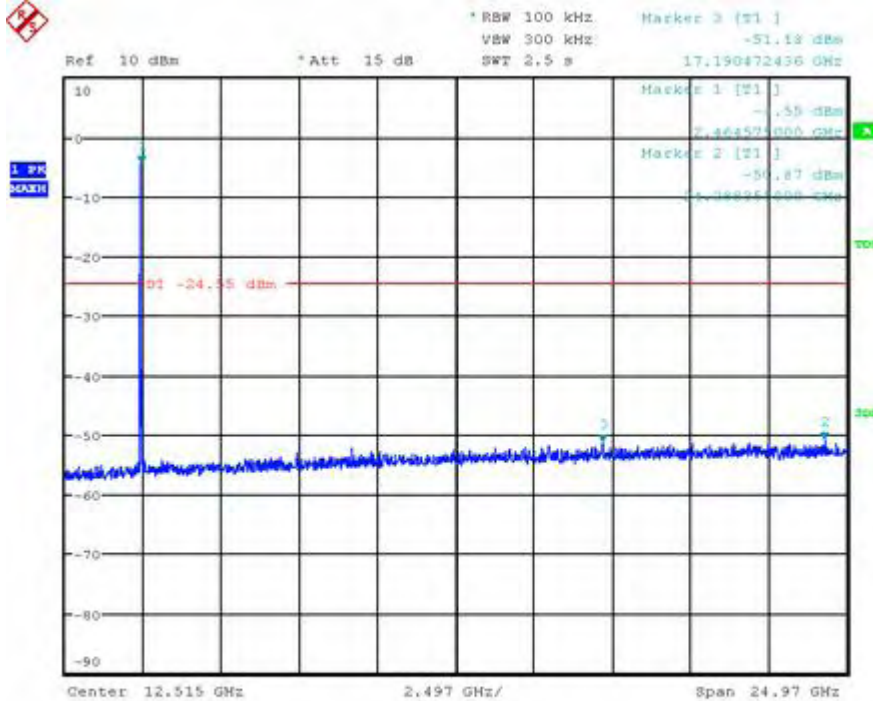

Date: 12.APR.2011 10:21:39

Note: The signal beyond the limit is carrier

802.11g, channel 11, 54Mbps
9kHz~30MHz

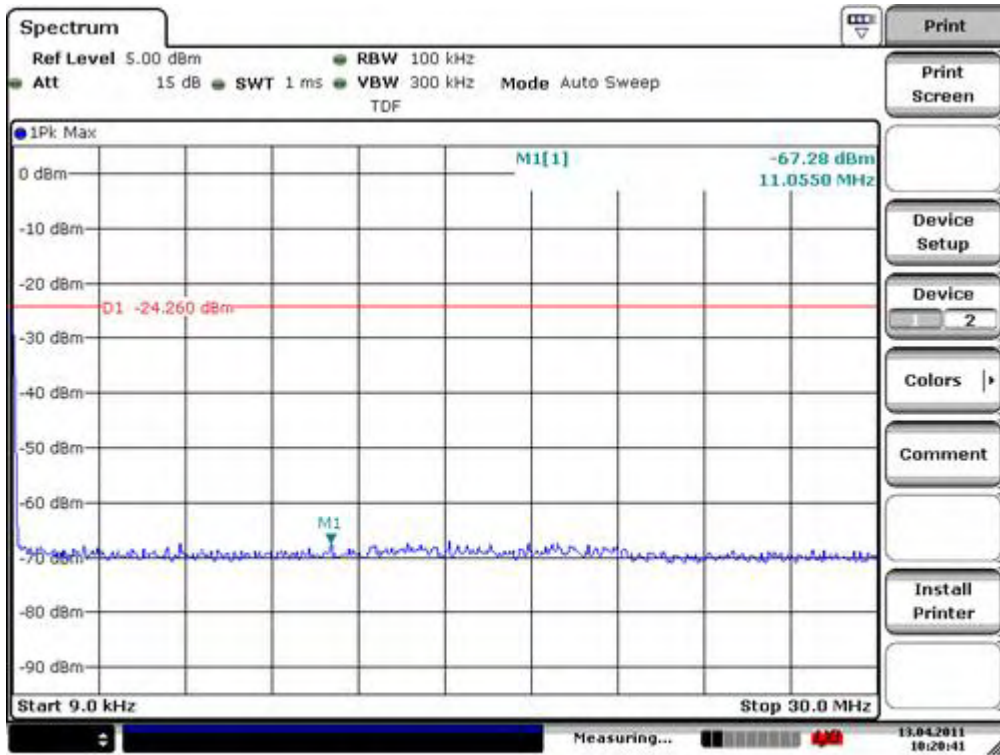

CH1 B 1M
 Date: 13.APR.2011 10:20:41

30MHz~25GHz

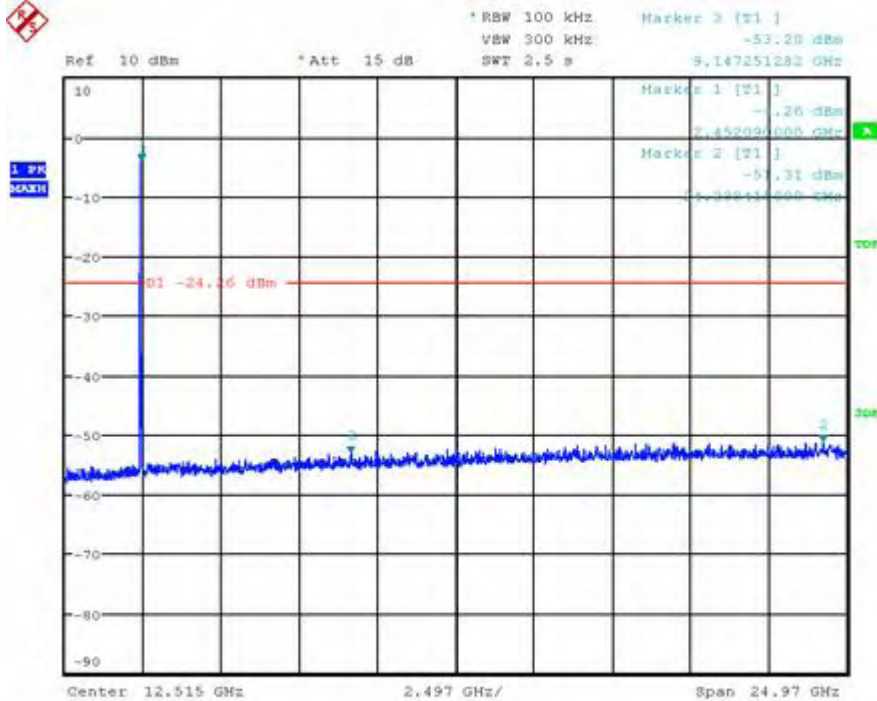

Date: 12.APR.2011 10:23:14

Note: The signal beyond the limit is carrier

7. Band edge measurement

7.1. Test Equipment

The following test equipment are used during the band edge test:

Item	Instrument	Manufacturer	Type No./Serial No	Due Date
1	Signal and Spectrum Analyzer	R & S	FSV7/ 101836	2011.12.02
2	10dB Attenuator	Agilent	8493C/ 76156	2011.12.19

7.2. Test Setup

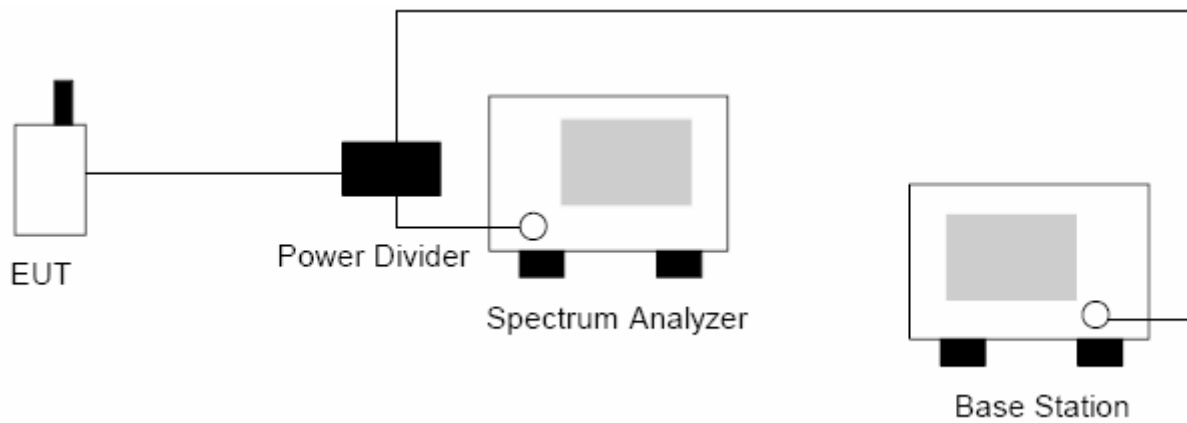

7.3. Limits

Limits	< (P-20dB)
Note: P is the highest level of the desired power ;	

7.4. Test Procedure

Band-edge Compliance of RF Conducted Emissions:

Use the following spectrum analyzer settings:

Span = wide enough to capture the peak level of the emission operating on the channel closest to the band edge, as well as any modulation products which fall outside of the authorized band of operation RBW \geq 1% of the span; VBW \geq RBW; Sweep = auto; Detector function = peak; Trace = max hold Allow the trace to stabilize. Set the marker on the emission at the band edge, or on the highest modulation product outside of the band, if this level is greater than that at the band edge. Enable the marker-delta function, then use the marker-to-peak function to move the marker to the peak of the in-band emission.

7.5. Test Specification

According to CFR 47 FCC Part 15.247

7.6. EUT Operation

See chapter 1.2 of this test report

7.7. Test Result

channel	mode	Data Rate (Mbps)	Measured Level (dBc)	Limit (dBc)	Result
1	802.11b	1	Refer to picture	<-20	Pass
		5.5	Refer to picture	<-20	Pass
		11	Refer to picture	<-20	Pass
	802.11g	6	Refer to picture	<-20	Pass
		24	Refer to picture	<-20	Pass
		54	Refer to picture	<-20	Pass
11	802.11b	1	Refer to picture	<-20	Pass
		5.5	Refer to picture	<-20	Pass
		11	Refer to picture	<-20	Pass
	802.11g	6	Refer to picture	<-20	Pass
		24	Refer to picture	<-20	Pass
		54	Refer to picture	<-20	Pass

Band-edge, 802.11b, channel 1, 1Mbps

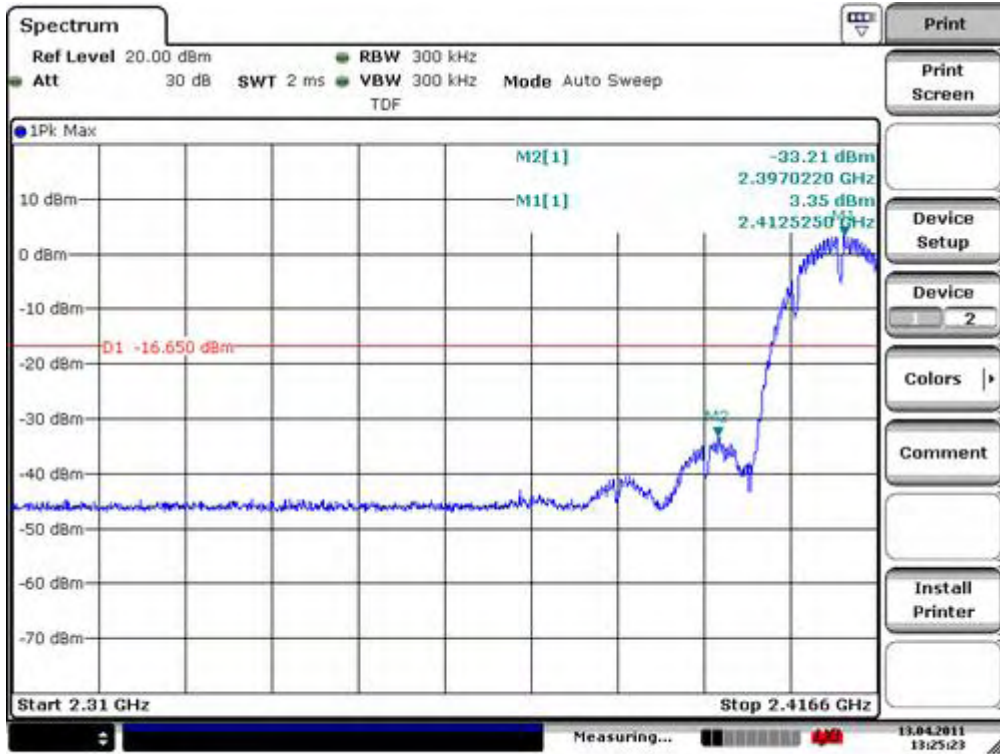

CH1 B 1M

Date: 13.APR.2011 13:25:23

Band-edge, 802.11b, channel 1, 5.5Mbps

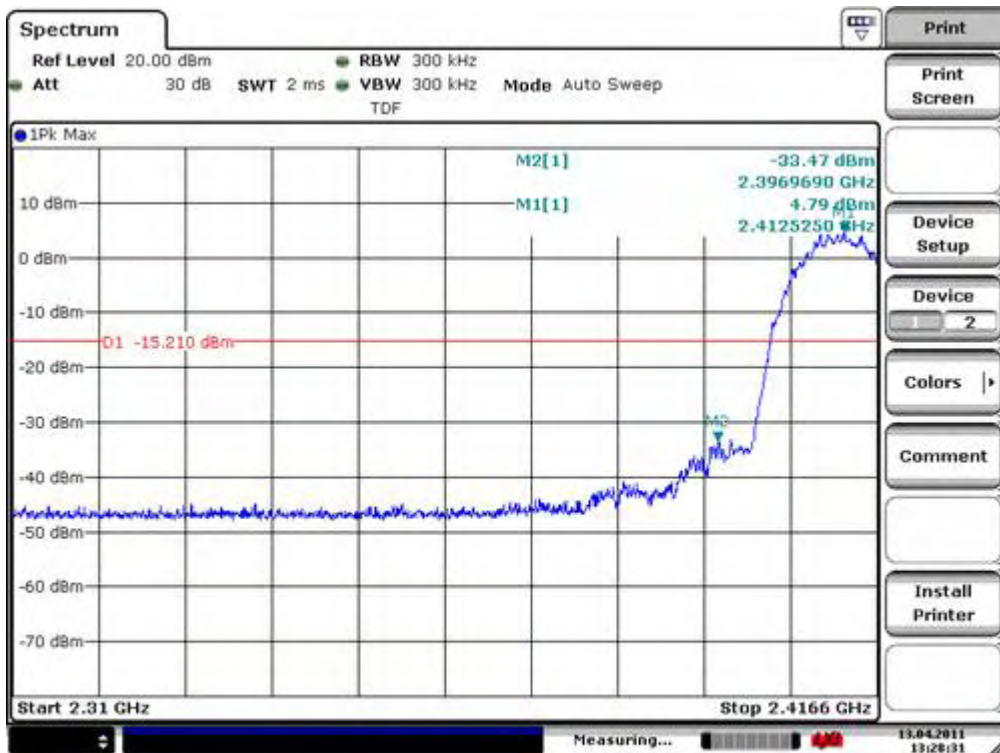

CH1 B 1M

Date: 13.APR.2011 13:28:31

Band-edge, 802.11b, channel 1, 11Mbps

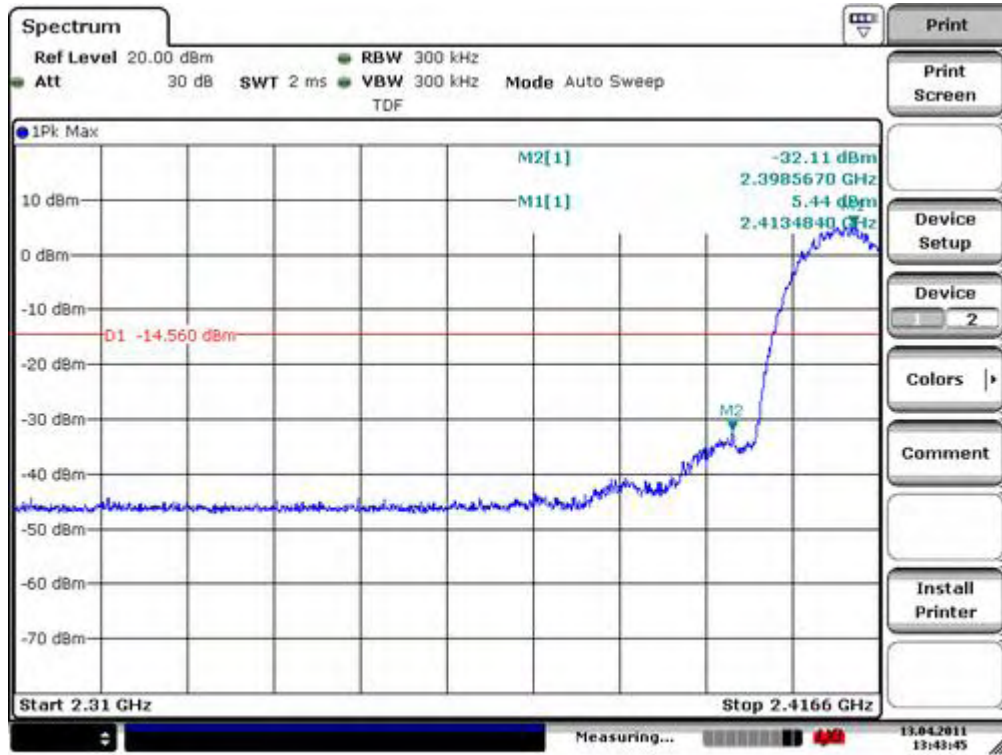

CH1 B 1M
 Date: 13.APR.2011 13:43:45

Band-edge, 802.11b, channel 11, 1Mbps



CH1 B 1M
 Date: 13.APR.2011 14:15:06

Band-edge, 802.11b, channel 11, 5.5Mbps



CH1 B 1M
Date: 13.APR.2011 14:21:29

Band-edge, 802.11b, channel 11, 11Mbps



CH1 B 1M
Date: 13.APR.2011 14:23:33

Band-edge, 802.11g, channel 1, 6Mbps

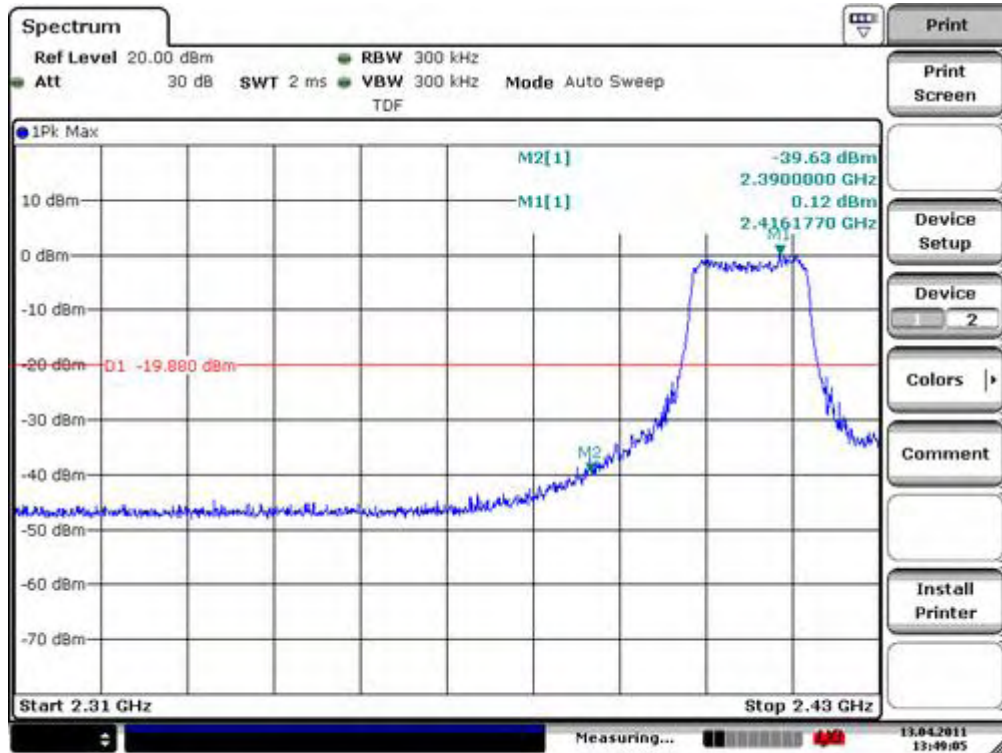

CHI B 1M
Date: 13.APR.2011 13:49:05

Band-edge, 802.11g, channel 1, 24Mbps



CHI B 1M
Date: 13.APR.2011 13:50:45

Band-edge, 802.11g, channel 1, 54Mbps

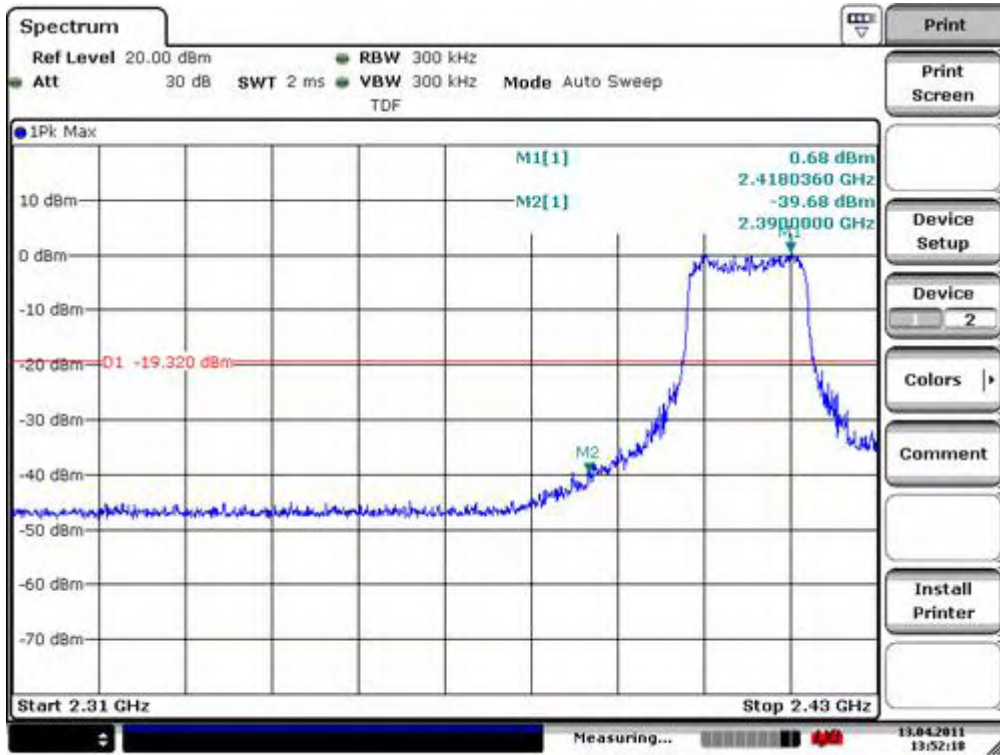

CH1 B 1M
Date: 13.APR.2011 13:52:18

Band-edge, 802.11g, channel 11, 6Mbps

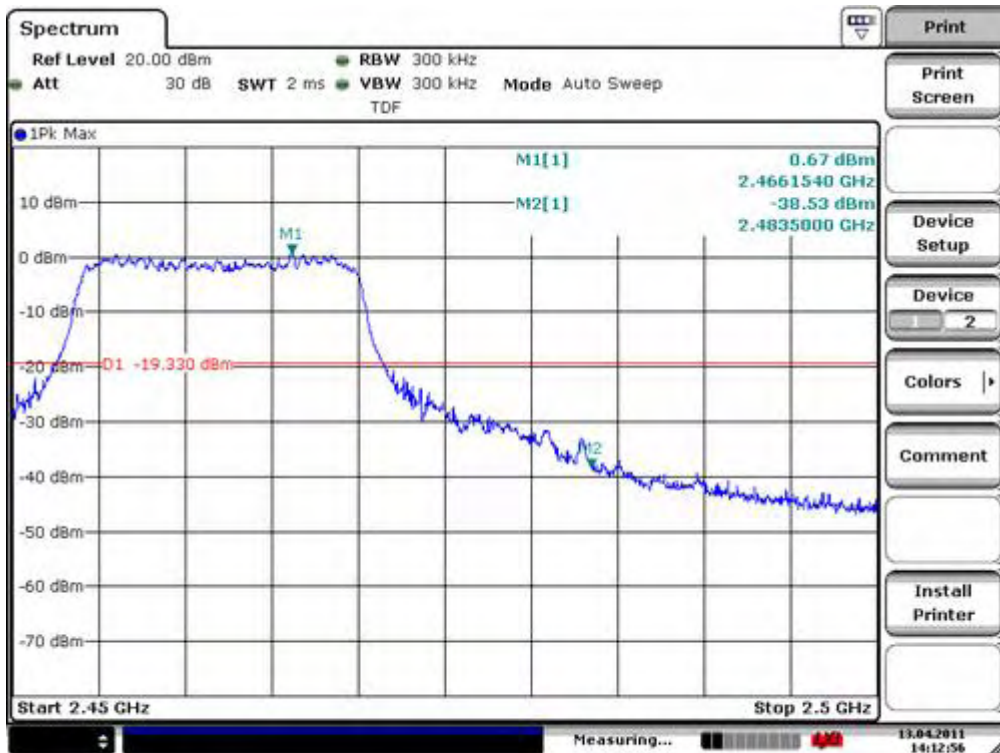

CH1 B 1M
Date: 13.APR.2011 14:12:56

Band-edge, 802.11g, channel 11, 24Mbps

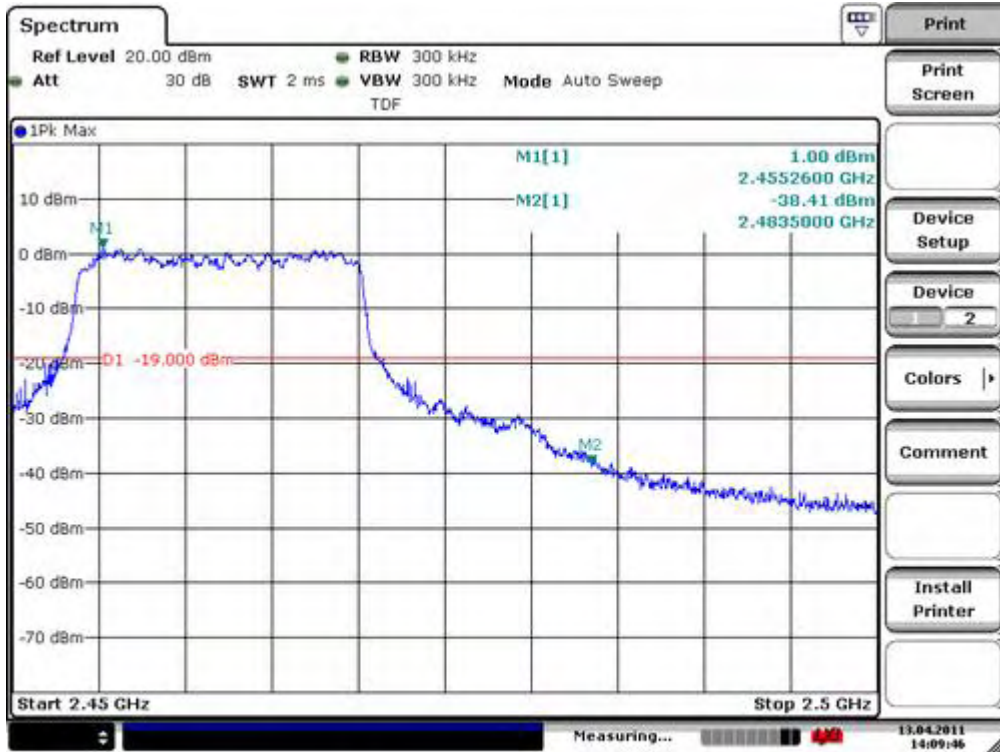

CH1 B 1M
Date: 13.APR.2011 14:09:46

Band-edge, 802.11g, channel 11, 54Mbps

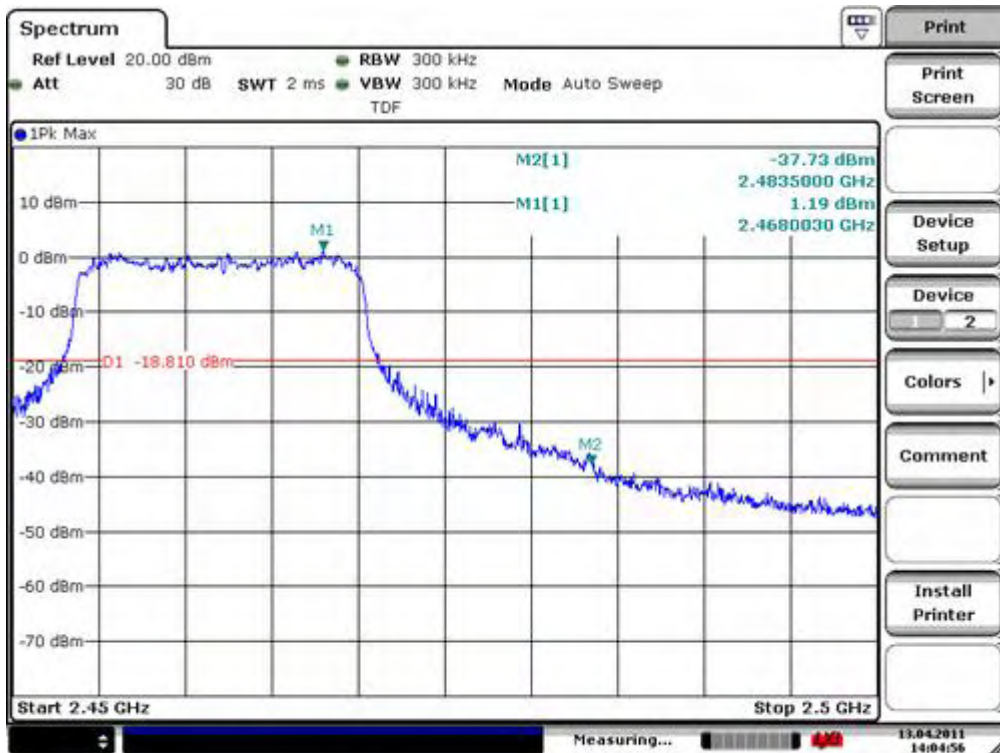

CH1 B 1M
Date: 13.APR.2011 14:04:57

8. Spurious Emissions (Radiation)

8.1. Test Equipment

The following test equipment are used during the Spurious Emissions (Radiation) test

Item	Instrument	Manufacturer	Type No./Serial No	Due Date
1	EMI Test Receiver	R & S	ESI 26/ 838786/011	2011.12.22
2	Double-Ridged Waveguide Horn Antenna	HF 906	HF 906/ 100023	2011.06.17
3	Loop Field Strength Measuring System	SCHWARZBECK	FMZB 1516/ 114	2011.11.29
4	SAC 10m channels	R & S	CP1.2/X1-3GHz / N/A	2011.09.12
5	SAC 10m channels	R & S	CP2/X1-18GHz / N/A	2011.09.12
6	BiConiLog Antenna	ETS-LINDGREN	3142C/ 00091725	2011.11.04
7	Pre-Amplifier	R & S	AFS42-00101800/ 1096336	2012.01.19
8	Spectrum Analyzer	R & S	FSU 26/ 200932	2011.12.05
9	Pyramidal Horn Antenna	ETS-LINDGREN	3160-09/ 00086671	2011.06.17
10	Amplifier	MITEQ	AFS4-00102650-42-8P-4 / 1405286	2011.06.11

8.2. Test Setup

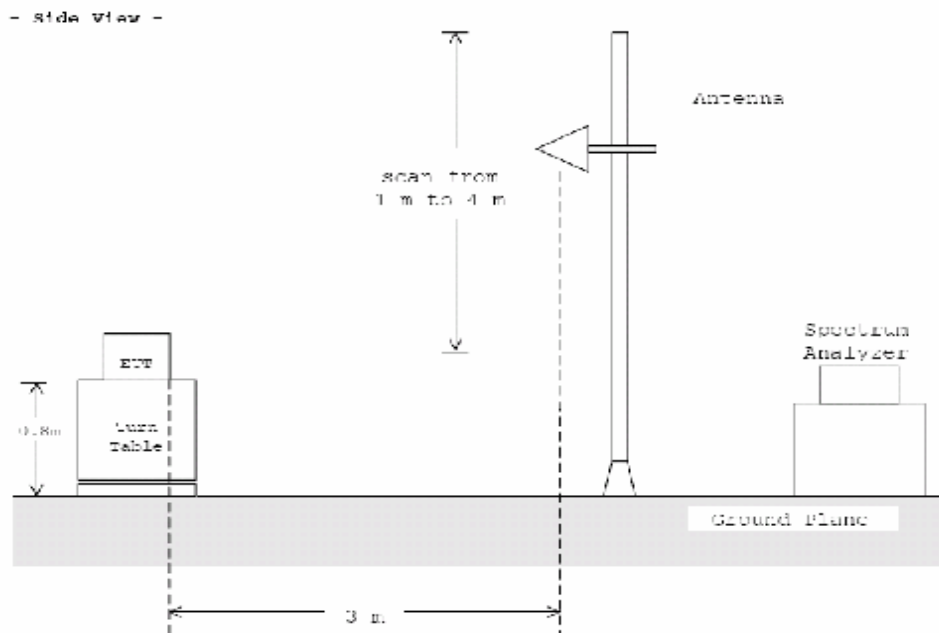

8.3. Limits

Frequency (MHz)	Limits (dB uV/m)	Measured distance (m)
0.009 – 0.490	107.60-72.88	10
0.490 – 1.705	52.88-42.05	
1.705 – 30	48.62	
30~88	40.00	3
88~216	43.52	
216-960	46.02	
960-1000	54.00	

8.4. Test Procedure

Radiated Emission (9 kHz – 30 MHz) :

Spurious emissions from the EuT are measured in the frequency range of 9 kHz to 30 MHz using a tuned receiver and a shielded loop antenna. The antenna was positioned 3, 10 or 30 meters horizontally from the EuT. Measurements have been made in all three orthogonal axes and the shielded loop antenna was rotated to locate the maximum of the emissions. The emission limits are based on measurements employing a CISPR quasi-peak detector except for the frequency bands 9-90 kHz, 110-490 kHz.

Radiated Emission (30 MHz – 1000 MHz) :

According to description of ANSI C63.4-2003 sec.13.1.4 and RSS 210 sec.2.6, the preliminary radiated emissions measurement were carried out. The preliminary radiated measurements were performed at the measurement distance that specified for compliance to determine the emission characteristics of the EUT. The EUT configuration (in X, Y and Z axis), cable configuration and mode of operation were determined for producing the maximum level of emissions. These configurations were used for the final radiated emissions measurements. The measurement is carried out using a spectrum analyzer or receiver. The Quasi-peak detector is used and RBW is set to 120kHz. The antenna height and turn table rotation is adjusted until the maximum power value is founded on spectrum analyzer or receiver.

Radiated Emission (Above 1 GHz) :

According to description of ANSI C63.4-2003 sec.13.1.4 and RSS 210 sec.2.6, the preliminary radiated emissions measurement were carried out. The preliminary radiated measurements were performed at the measurement distance that specified for compliance to determine the emission characteristics of the EUT. The EUT configuration (in X, Y and Z axis), cable configuration and mode of operation were determined for producing the maximum level of emissions. These configurations were used for the final radiated emissions measurements. The measurement is carried out using a spectrum analyzer or receiver. The spectrum analyzer scans from 1GHz to 25GHz (higher than the 10th harmonic of the carrier). The peak detector is used for Peak limit and RBW is set to 1MHz ,VBW \geq 3RBW. The peak detector is used for Average limit and RBW is set to 1MHz ,VBW is 10Hz. The antenna height and turn table rotation is adjusted until the maximum power value is founded on spectrum analyzer or receiver.

8.5. Test Specification

According to CFR 47 FCC Part 15.247, FCC Part 15.209

8.6. EUT Operation

See chapter 1.2 of this test report.

8.7. Test Result

Radiated Emission (9 kHz – 30 MHz) :

All configurations of EUT have been investigated and the worst case mode has been listed.

Mode of EUT:			802.11b			
Antenna polarity: X, Test distance: at 10m						
Frequency (MHz)	Antenna Factor (dB/m)	Cable loss (dB)	Receiver reading (QP) (dBuV)	Emission Level (QP) (dBμV/m)	Limit (dBμV/m)	Margin (dB)
0.5201	19.99	0.15	10.96	31.10	52.38	21.28
7.5588	19.66	0.28	10.76	30.70	48.60	17.90
7.5707	19.66	0.28	11.36	31.30	48.60	17.30
Antenna polarity: Y, Test distance: at 10m						
7.5588	19.66	0.28	19.06	39.00	48.60	9.60
7.6782	19.67	0.28	18.55	38.50	48.60	10.10
8.6573	19.77	0.30	15.33	35.40	48.60	13.20
Antenna polarity: Z, Test distance: at 10m						
1.1589	19.85	0.45	6.00	26.30	45.44	19.14
1.5709	19.97	0.36	5.57	25.90	42.81	16.91
1.6604	20.00	0.31	5.79	26.10	42.33	16.23

Remark:

1. Emission level (dBuV/m) = Reading (dBuV) + Correction Factor (dB/m).
2. Correction Factor (dB/m) = Antenna Factor (dB/m) + Cable Factor (dB).
3. The other emission levels were very low against 20dB from the limit.
4. Margin value = Emission level – Limit value.

All configurations of EUT have been investigated and the worst case mode has been listed.

Mode of EUT:			802.11g			
Antenna polarity: X, Test distance: at 10m						
Frequency (MHz)	Antenna Factor (dB/m)	Cable loss (dB)	Receiver reading (QP) (dBuV)	Emission Level (QP) (dBuV/m)	Limit (dBuV/m)	Margin (dB)
0.9679	19.81	0.36	6.73	26.90	47.00	20.10
1.1171	19.84	0.43	6.93	27.20	45.76	18.56
1.6186	19.99	0.33	6.78	27.10	42.55	15.45
Antenna polarity: Y, Test distance: at 10m						
0.9380	19.82	0.35	9.03	29.20	47.28	18.08
1.0276	19.81	0.39	6.10	26.30	46.49	20.19
18.4540	20.34	0.46	5.70	26.50	48.60	22.10
Antenna polarity: Z, Test distance: at 10m						
1.4694	19.94	0.42	4.74	25.10	43.39	18.29
16.4899	20.26	0.44	5.41	26.10	48.60	22.50
21.7495	20.37	0.51	6.72	27.60	48.60	21.00

Remark:

1. Emission level (dBuV/m) = Reading (dBuV) + Correction Factor (dB/m).
2. Correction Factor (dB/m) = Antenna Factor (dB/m) + Cable Factor (dB).
3. The other emission levels were very low against 20dB from the limit.
4. Margin value = Emission level – Limit value.

Radiated Emission (30 MHz – 1000 MHz) :

All configurations of EUT have been investigated and the worst case mode has been listed.

Mode of EUT:			802.11b			
Antenna polarity & Test distance: horizontal at 3m						
Frequency (MHz)	Antenna Factor (dB/m)	Cable loss (dB)	Receiver reading (QP) (dBuV)	Emission Level (QP) (dBuV/m)	Limit (dBuV/m)	Margin (dB)
30.140281	17.22	0.46	-1.80	15.88	40.00	24.12
99.664564	7.98	0.29	1.29	9.55	43.52	33.97
189.564685	10.00	0.35	1.31	11.65	43.52	31.87
286.068460	12.84	0.37	0.44	13.65	46.02	32.37
457.655311	17.23	0.46	0.29	17.98	46.02	28.04
729.656430	22.22	0.52	1.92	24.66	46.02	21.36
Antenna polarity & Test distance: vertical at: 3m						
38.156313	12.90	0.37	6.99	20.25	40.00	19.75
50.310621	8.66	0.30	13.69	22.65	40.00	17.35
69.949900	6.50	0.25	3.14	9.89	40.00	30.11
308.361585	13.33	0.37	0.31	14.02	46.02	32.00
468.665446	17.85	0.46	0.03	18.34	46.02	27.68
607.025544	20.74	0.49	1.79	23.02	46.02	23.00

Remark:

1. Emission level (dBuV/m) = Reading (dBuV) + Correction Factor (dB/m).
2. Correction Factor (dB/m) = Antenna Factor (dB/m) + Cable Factor (dB).
3. The other emission levels were very low against 20dB from the limit.
4. Margin value = Emission level – Limit value.

All configurations of EUT have been investigated and the worst case mode has been listed.

Mode of EUT:			802.11g			
Antenna polarity & Test distance: horizontal at 3m						
Frequency (MHz)	Antenna Factor (dB/m)	Cable loss (dB)	Receiver reading (QP) (dBuV)	Emission Level (QP) (dBuV/m)	Limit (dBuV/m)	Margin (dB)
30.862235	16.83	0.45	-1.23	16.05	40.00	23.95
43.607214	10.75	0.37	3.73	14.84	40.00	25.16
154.408818	9.02	0.31	-1.06	8.27	43.52	35.25
171.903808	9.58	0.33	2.03	11.94	43.52	31.58
471.262525	17.99	0.46	0.78	19.23	46.02	26.79
677.314629	21.36	0.51	1.22	23.09	46.02	22.93
Antenna polarity & Test distance: vertical at: 3m						
41.330661	11.47	0.38	18.56	30.41	40.00	9.59
43.194389	10.88	0.37	17.83	29.08	40.00	10.92
62.929860	7.14	0.27	8.83	16.24	40.00	23.76
199.118236	9.82	0.34	-0.49	9.67	43.52	33.85
486.422846	18.25	0.46	0.01	18.72	46.02	27.30
702.585170	21.93	0.52	1.01	23.46	46.02	22.56

Remark:

1. Emission level (dBuV/m) = Reading (dBuV) + Correction Factor (dB/m).
2. Correction Factor (dB/m) = Antenna Factor (dB/m) + Cable Factor (dB).
3. The other emission levels were very low against 20dB from the limit.
4. Margin value = Emission level – Limit value.

Radiated Emission (Above 1000MHz) :

All configurations of EUT have been investigated and the worst case mode has been listed.

Mode of EUT:				802.11b			
Antenna polarity & Test distance: horizontal at 3m, PK							
Frequency (GHz)	Antenna Factor (dB/m)	Cable Loss (dB)	Preamplifier (dB)	Receiver Reading (dBuV)	Emission Level (dBµV/m)	Limit (dBµV/m)	Margin (dB)
1.0640	24.29	5.02	-38.23	94.30	36.80	74.00	37.20
1.6732	26.50	6.33	-38.60	97.26	38.50	74.00	35.50
1.6484	26.37	6.29	-38.58	98.06	39.40	74.00	34.60
2.3900	28.34	6.98	/	13.18	48.50	74.00	25.50
2.4835	28.42	7.09	/	13.79	49.30	74.00	24.70
5.7270	35.42	11.98	-40.94	113.58	49.20	74.00	24.80
9.6360	38.48	16.22	-37.69	113.76	53.80	74.00	20.20
18.0000	44.60	23.26	-38.68	123.62	63.60	74.00	10.40
Antenna polarity & Test distance: vertical at: 3m, PK							
1.0484	24.25	4.99	-38.22	94.08	36.60	74.00	37.40
1.3892	25.27	5.77	-38.37	95.47	37.60	74.00	36.40
1.7236	26.76	6.42	-38.64	98.78	39.80	74.00	34.20
2.3900	28.34	6.98	/	12.58	47.90	74.00	26.10
2.4835	28.42	7.09	/	12.99	48.50	74.00	25.50
5.6670	35.20	12.04	-40.82	112.08	48.10	74.00	25.90
14.6130	40.30	19.91	-40.79	120.38	59.20	74.00	14.80
17.7300	44.11	22.91	-39.30	124.71	64.20	74.00	9.80

Remark:

1. Emission level (dBuV/m) = Reading (dBuV) + Correction Factor (dB/m).
2. Correction Factor (dB/m) = Antenna Factor (dB/m) + Cable Factor (dB)- preamp(dB).
3. The other emission levels were very low against 20dB from the limit.
4. Margin value = Emission level – Limit value.

All configurations of EUT have been investigated and the worst case mode has been listed.

Mode of EUT:				802.11b			
Antenna polarity & Test distance: horizontal at 3m, AV							
1.0656	24.30	5.03	-38.23	29.39	20.48	54.00	33.52
1.5688	25.96	6.14	-38.54	28.95	22.50	54.00	31.50
1.8180	27.25	6.60	-38.69	28.26	23.43	54.00	30.57
2.3900	28.34	6.98	/	3.28	38.60	54.00	15.40
2.4835	28.42	7.09	/	2.59	38.10	54.00	15.90
4.2990	32.62	10.35	-40.35	26.89	29.51	54.00	24.49
14.6010	40.32	19.85	-40.76	22.95	42.36	54.00	11.64
17.9280	44.47	23.21	-38.98	20.28	48.98	54.00	5.02
Antenna polarity & Test distance: vertical at: 3m, AV							
1.0200	24.16	4.92	-38.21	31.65	22.52	54.00	31.48
1.2188	24.76	5.38	-38.25	30.61	22.50	54.00	31.50
1.6932	26.60	6.36	-38.61	30.67	25.02	54.00	28.98
2.3900	28.34	6.98	/	3.08	38.40	54.00	15.60
2.4835	28.42	7.09	/	3.99	39.50	54.00	14.50
5.4270	34.42	11.67	-40.70	26.92	32.31	54.00	21.69
14.5440	40.42	19.80	-40.48	23.36	43.10	54.00	10.90
17.9280	44.47	23.21	-38.98	22.56	51.26	54.00	2.74

Remark:

1. Emission level (dBuV/m) = Reading (dBuV) + Correction Factor (dB/m).
2. Correction Factor (dB/m) = Antenna Factor (dB/m) + Cable Factor (dB)- preamp(dB).
3. The other emission levels were very low against 20dB from the limit.
4. Margin value = Emission level – Limit value.

All configurations of EUT have been investigated and the worst case mode has been listed.

Mode of EUT:				802.11g			
Antenna polarity & Test distance: horizontal at 3m, PK							
Frequency (GHz)	Antenna Factor (dB/m)	Cable Loss (dB)	Preamplifier (dB)	Receiver Reading (dBuV)	Emission Level (dB μ V/m)	Limit (dB μ V/m)	Margin (dB)
1.1912	24.67	5.32	-38.26	46.30	38.04	74.00	35.97
1.5208	25.71	6.03	-38.52	45.20	38.42	74.00	35.58
2.3900	28.34	6.98	/	13.78	49.10	74.00	24.90
2.4835	28.42	7.09	/	13.79	49.30	74.00	24.70
2.2420	28.39	7.35	-39.01	44.48	41.21	74.00	32.79
6.9570	37.23	13.32	-40.54	40.93	50.94	74.00	23.06
13.8180	41.27	19.29	-39.69	36.89	57.76	74.00	16.24
17.9130	44.44	23.26	-39.05	34.90	63.55	74.00	10.45
Antenna polarity & Test distance: vertical at: 3m, PK							
1.2664	24.90	5.49	-38.30	45.60	37.68	74.00	36.32
1.8780	27.57	6.68	-38.76	44.51	40.00	74.00	34.00
2.3900	28.34	6.98	/	14.88	50.20	74.00	23.80
2.4835	28.42	7.09	/	16.59	52.10	74.00	21.90
2.9932	29.59	8.55	-39.70	44.69	43.12	74.00	30.88
3.9300	32.32	9.84	-40.12	43.39	45.42	74.00	28.58
14.5230	40.46	19.89	-40.38	37.90	57.87	74.00	16.13
17.9640	44.54	23.40	-38.83	34.20	63.31	74.00	10.69

Remark:

1. Emission level (dB μ V/m) = Reading (dBuV) + Correction Factor (dB/m).
2. Correction Factor (dB/m) = Antenna Factor (dB/m) + Cable Factor (dB) - preamp(dB).
3. The other emission levels were very low against 20dB from the limit.
4. Margin value = Emission level – Limit value.

All configurations of EUT have been investigated and the worst case mode has been listed.

Mode of EUT:				802.11 g			
Antenna polarity & Test distance: horizontal at 3m, AV							
1.1912	24.67	5.32	-38.26	31.71	23.45	54.00	30.55
1.4548	25.46	5.91	-38.41	30.46	23.43	54.00	30.57
2.1400	28.31	7.18	-38.93	30.50	27.06	54.00	26.94
2.3900	28.34	6.98	/	3.28	38.60	54.00	15.40
2.4835	28.42	7.09	/	3.59	39.10	54.00	14.90
4.3620	32.64	10.39	-40.34	29.88	32.57	54.00	21.43
7.0500	37.35	13.43	-40.47	27.90	38.21	54.00	15.79
9.6660	38.50	16.20	-37.85	24.38	41.23	54.00	12.77
Antenna polarity & Test distance: vertical at: 3m, AV							
1.3008	25.00	5.56	-38.35	35.32	27.53	54.00	26.47
1.8516	27.43	6.63	-38.72	34.30	29.64	54.00	24.36
2.1392	28.31	7.18	-38.93	34.34	30.90	54.00	23.10
2.3900	28.34	6.98	/	4.18	39.50	54.00	14.50
2.4835	28.42	7.09	/	4.79	40.30	54.00	13.70
3.5640	31.37	9.30	-40.06	29.95	30.56	54.00	23.44
7.9500	37.35	14.42	-40.16	26.34	37.95	54.00	16.05
17.6640	44.00	22.49	-39.18	22.23	49.53	54.00	4.47

Remark:

1. Emission level (dBuV/m) = Reading (dBuV) + Correction Factor (dB/m).
2. Correction Factor (dB/m) = Antenna Factor (dB/m) + Cable Factor (dB)- preamp(dB).
3. The other emission levels were very low against 20dB from the limit.
4. Margin value = Emission level – Limit value.

9. Test Setup Photo

9.1. Radiation Emission Setup Photo

9kHz~30MHz



(30~1000)MHz



(1000-18000)MHz



(18000-26000)MHz



9.2. RF conducted Test Setup Photo



9.3. EUT Axis of Setup Photo

X Axis



Y Axis



Z Axis



10. Internal Photo

Battery & mainboard



Front & USB cable



Mainboard

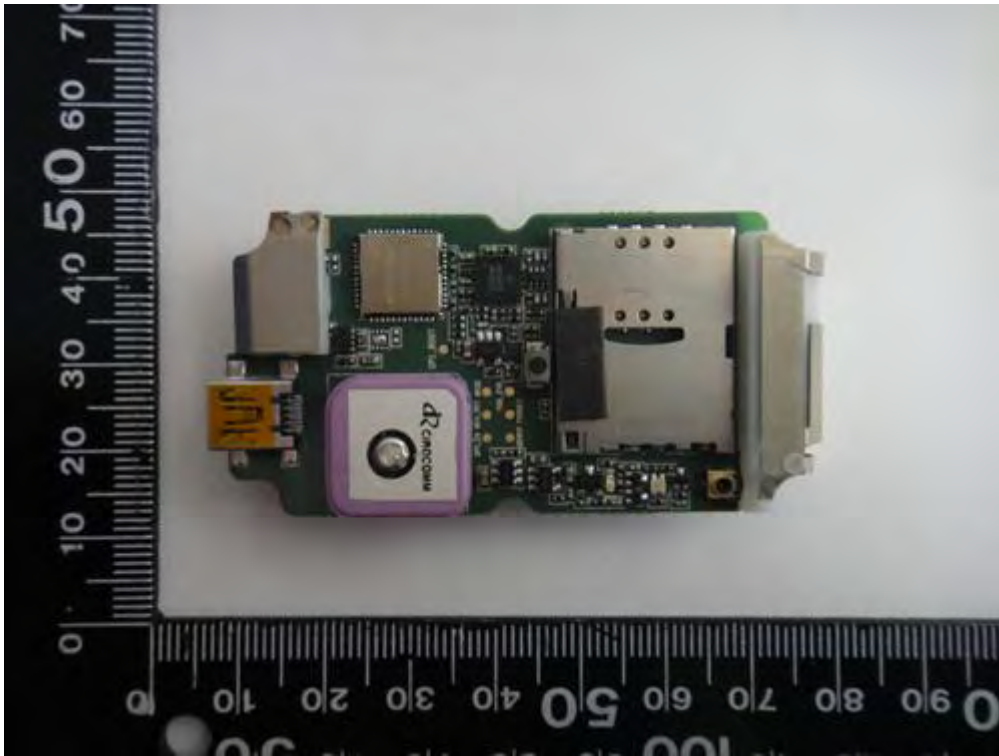

Rear & adapter



Reference: Laboratory of License



DET NORSKE VERITAS

STATEMENT OF RECOGNITION

STATEMENT NO. 639 -10 – LAB22
The statement consists of 3 pages

This is to confirm that the
EMC LABORATORY

Within

Shanghai Institute of Measurement and Testing Technology

with legal identity
Shanghai Institute of Measurement and Testing Technology
716 Yi Shan Road, Shanghai, China

has been found to comply with the requirements of DNV towards subcontractors of EMC testing services in conjunction with the EMC Directive and in the voluntary field.

The acceptance is based on a formal Quality Audit and follow-ups according to relevant parts of ISO/IEC Guide 17025 (2005), in accordance with the requirements of the DNV Laboratory Quality Manual towards subcontractors.

<p style="text-align: center;"><i>Place and date</i> DNV Shanghai, 26 June, 2010 for Det Norske Veritas Certification AS (Competent and Notified Body no. 575)</p>	<p style="text-align: right;"><i>This Statement is valid until</i> 26 June, 2013</p>
--	--

 <hr style="width: 80%; margin: 0 auto;"/> <p>Zhang Qing Ping <i>Product Certification Manager</i></p>	<p>DNV local office: DNV Shanghai</p> 	 <hr style="width: 80%; margin: 0 auto;"/> <p>Sean Lee <i>Technical Reviewer</i></p>
--	---	--

Notice: This Statement is subject to terms and conditions overleaf. Any significant change in the laboratory facilities or in the quality system may render this Statement invalid.
 If any person suffers loss or damage which is proved to have been caused by any negligent act or omission of Det Norske Veritas, then Det Norske Veritas shall pay compensation to such person for his proved direct loss or damage. However, the compensation shall not exceed an amount equal to ten times the fee charged for the service in question, provided that the maximum compensation shall never exceed USD 2 million. In this provision "Det Norske Veritas" shall mean the Foundation Det Norske Veritas as well as all its subsidiaries, directors, officers, employees, agents and any other acting on behalf of Det Norske Veritas.

DET NORSKE VERITAS AS SHANGHAI BRANCH
HOUSE NO.9, 1591 HONG QIAO ROAD, SHANGHAI 200336, P.R. CHINA
TEL: 86(0) 21 3208 4518

Page 1 of 3



Statement No.: 639 – 10 –LAB22

Project No.: PRJC-20846-2007-PRC-RGC

Audit information*Initial audit:*

- Date of Audit: 2002-10-10~2002-10-11
- Initial Certification Audit Report: 2002-10-11; 2002-11-16/final
- Closing of Non-conformities: 2002-11-16

Re-Certification Audit:

- Date of Audit: 2010-06-02
- Re-Certification Audit Report: 2010-06-21/final
- Audit Report Identification: 600474

Scope of recognition EMC/LVD

- EN 55011 (CISPR 11)
 - EN 55012 (CISPR 12)
 - EN 55013 (CISPR 13)
 - EN 55014-1/-2 (CISPR 14-1/-2)
 - EN 55015 (CISPR 15)
 - EN 55022 (CISPR 22)
 - EN 55024 (CISPR 24)
 - EN 55025 (CISPR 25)
 - EN/IEC 61000-3-2/EN60555-2/IEC555-2
 - EN/IEC 61000-3-3/EN60555-3/IEC555-3
 - EN/IEC 61000-4-2/IEC801-2
 - EN/IEC 61000-4-3/ENV50140/IEC801-3
 - EN/IEC 61000-4-4/IEC801-4
 - EN/IEC 61000-4-5/ENV50142
 - EN/IEC 61000-4-6/ENV50141
 - EN/IEC 61000-4-8
 - EN/IEC 61000-4-9
 - EN/IEC 61000-4-11
 - EN/IEC 61000-4-12
 - EN/IEC 61000-4-29
 - EN/IEC 61000-6-1
 - EN/IEC 61000-6-2
 - EN/IEC 61000-6-3
 - EN/IEC 61000-6-4
-
- EN 12015
 - EN 12016
 - EN 60065
 - EN 60601-1
 - EN 60950





Statement No.: 639 – 10 –LAB22

Project No.: PRJC-20846-2007-PRC-RGC

- EN 50091-2
- EN 50121
- EN 50130-4
- EN 60601-1-2
- EN/IEC 60974-10
- EN 61010-1
- EN 61326
- EN 61547
- EN 62040-2
- EN 301 489-01
- EN 301 489-02
- EN 301 489-03
- EN 301 489-07
- EN 301 489-08
- EN 301 489-17
- EN 301 489-23
- EN 301 489-24
- EN 301 489-25
- EN 301 908-01
- EN 300 328
- EN 300 386
- EN 300 826
- ISO 7637
- ISO 10805
- ISO 11452
- ISO 16750-2
- 3GPP TS 25.113
- ETSI TS 134 124

Application/Limitations

Light/heavy industry, ITE, heavy power device, car and communication exchange device.

Documentation

- Company Document: S-QAM-01-xx for the QM-quality manual; S-ADP-xx for procedure; S-EMP-xx for daily operation working instruction.
- Accredited by A2LA on 2008-05-28
- NVLAP on 2010-01-01
- VCCI valid until 2013-01-23
- FCC on 2011-10-30
- CNAL on 2009-09-21



END OF STATEMENT

FEDERAL COMMUNICATIONS COMMISSION

Laboratory Division
7435 Oakland Mills Road
Columbia, MD 21046

November 30, 2005

Registration Number: 142171

SIMT EMC Lab
716 Yi Shan Road
Shanghai City,
China

Attention: Gong Zeng

Re: Measurement facility located at Shanghai City
Anechoic chamber (3 & 10 meters)
Date of Renewal: November 30, 2005

Dear Sir or Madam:

Your request for renewal of the registration of the subject measurement facility has been received. The information submitted has been placed in your file and the registration has been renewed. The name of your organization will remain on the list of facilities whose measurement data will be accepted in conjunction with applications for Certification under Parts 15 or 18 of the Commission's Rules. Please note that the file must be updated for any changes made to the facility and the registration must be renewed at least every three years.

Measurement facilities that have indicated that they are available to the public to perform measurement services on a fee basis may be found on the FCC website www.fcc.gov under E-Filing, OET Equipment Authorization Electronic Filing, Test Firms.

Sincerely,



Phyllis Parrish
Information Technician



United States Department of Commerce
National Institute of Standards and Technology

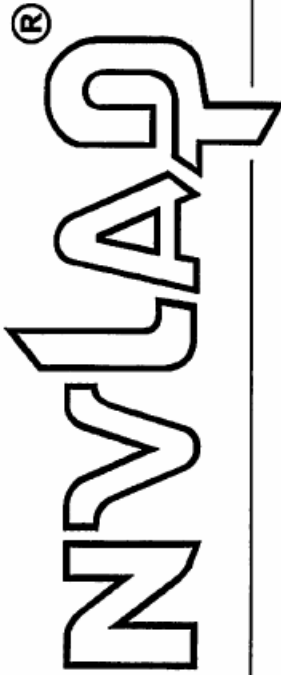

Certificate of Accreditation to ISO/IEC 17025:2005

NVLAP LAB CODE: 200632-0

Shanghai Institute of Measurement and Testing Technology EMC Lab

Shanghai City, 200233
P.R. CHINA

*is accredited by the National Voluntary Laboratory Accreditation Program for specific services,
listed on the Scope of Accreditation, for.*

ELECTROMAGNETIC COMPATIBILITY AND TELECOMMUNICATIONS

*This laboratory is accredited in accordance with the recognized International Standard ISO/IEC 17025:2005.
This accreditation demonstrates technical competence for a defined scope and the operation of a laboratory quality
management system (refer to joint ISO-IAC-IAF Communiqué dated January 2009).*

2011-01-01 through 2011-12-31

Effective dates



Dolly S. Bucea
For the National Institute of Standards and Technology

NVLAP-01C (REV. 2009-01-28)