

Königswinkel 10

32825 Blomberg, Germany

Phone +49 (0) 52 35 95 00-0

Fax +49 (0) 52 35 95 00-10

office@phoenix-testlab.de

www.phoenix-testlab.de

Test Report

Report Number:

F153143E1

Equipment under Test (EUT):

**UHF RFID read/write device
TN902-Q175L200-H1147**

Applicant:

Hans Turck GmbH & Co. KG

Manufacturer:

Werner Turck GmbH & Co. KG





Deutsche
Akkreditierungsstelle
D-PL-17186-01-01
D-PL-17186-01-02
D-PL-17186-01-03

References

- [1] **ANSI C63.10: 2013** American National Standard of Procedures for Compliance Testing of Unlicensed Wireless Devices
- [2] **FCC CFR 47 Part 15 (July 2014)** Radio Frequency Devices
- [3] **RSS-247 Issue 1 (May 2015)** Licence-exempt Radio Apparatus (All Frequency Bands): Category I Equipment
- [4] **RSS-Gen Issue 4 (November 2014)** General Requirements for Compliance of Radio Apparatus
- [5] **DA 00-705 (March 30, 2000)** Filing and Measurement Guidelines for Frequency Hopping Spread Spectrum Systems

TEST RESULT

The requirements of the tests performed as shown in the overview (clause 4) were fulfilled by the equipment under test.
The complete test results are presented in the following.

Test engineer:	Thomas KÜHN		08/26/2015
	Name	Signature	Date
Authorized reviewer:	Bernd STEINER		08/26/2015
	Name	Signature	Date

This test report is only valid in its original form.

Any reproduction of its contents in extracts without written permission of the accredited test laboratory PHOENIX TESTLAB GmbH is prohibited.

The test results herein refer only to the tested sample. PHOENIX TESTLAB GmbH is not responsible for any generalisations or conclusions drawn from these test results concerning further samples. Any modification of the tested samples is prohibited and leads to the invalidity of this test report. Each page necessarily contains the PHOENIX TESTLAB Logo and the TEST REPORT NUMBER.

This test report is valid in hardcopy form as well as in electronic form.

Contents:	Page
1 Identification	4
1.1 Applicant.....	4
1.2 Manufacturer	4
1.3 Test laboratory	4
1.4 EUT (Equipment Under Test).....	5
1.5 Technical data of equipment	5
1.6 Dates	5
2 Operational states	6
3 Additional information.....	7
4 Overview.....	7
5 Test results	8
5.1 20 dB bandwidth	8
5.1.1 Method of measurement (20 dB bandwidth).....	8
5.1.2 Test results (20 dB bandwidth)	9
5.2 Carrier frequency separation.....	11
5.2.1 Method of measurement (carrier frequency separation)	11
5.2.2 Test results (carrier frequency separation)	12
5.3 Number of hopping frequencies.....	14
5.3.1 Method of measurement (number of hopping frequencies).....	14
5.3.2 Test results (number of hopping frequencies)	15
5.4 Dwell time.....	16
5.4.1 Method of measurement (dwell time)	16
5.4.2 Test results (dwell time)	17
5.5 Maximum peak output power	18
5.5.1 Method of measurement (maximum peak output power)	18
5.5.2 Test results (maximum peak output power).....	19
5.6 Radiated emissions	21
5.6.1 Method of measurement (radiated emissions)	21
5.6.2 Test results (radiated emissions)	28
5.6.2.1 Preliminary radiated emission measurement	28
5.6.2.2 Final radiated emission measurement (30 MHz to 1 GHz)	36
5.6.2.3 Final radiated emission measurement (1 GHz to 10 GHz).....	40
5.7 Conducted emissions on power supply lines (150 kHz to 30 MHz).....	43
5.7.1 Method of measurement	43
5.7.2 Test results (conducted emissions on power supply lines)	44
6 Test equipment and ancillaries used for tests.....	46
7 Report history	47
8 List of annexes	47

1 Identification

1.1 Applicant

Name:	Hans Turck GmbH & Co. KG
Address:	Witzlebenstr. 7 45472 Mülheim an der Ruhr
Country:	Germany
Name for contact purposes:	Mr. Werner BIBERNELL
Phone:	+49 208 49 52 - 206
Fax:	+49 208 49 52 - 264
eMail Address:	Werner.Bibernell@turck.com
Applicant represented during the test by the following person:	-

1.2 Manufacturer

Name:	Werner Turck GmbH & Co. KG
Address:	Goethestraße 7 58553 Halver
Country:	Germany
Name for contact purposes:	Dr.-Ing. Michael REPPEL
Phone:	+49 23 53 709 - 61 29
Fax:	+49 23 53 709 - 61 74
eMail Address:	michael.reppel@turck.com
Manufacturer represented during the test by the following person:	-

1.3 Test laboratory

The tests were carried out at: **PHOENIX TESTLAB GmbH**
Königswinkel 10
32825 Blomberg
Germany

accredited by DGA Deutsche Gesellschaft Akkreditierungsstelle GmbH (DAkkS) in compliance with DIN EN ISO/IEC 17025 under Reg. No. D-PL-17186-01-02, FCC Test site registration number 90877 and Industry Canada Test site registration IC3469A-1.

1.4 EUT (Equipment Under Test)

Test object: *	UHF RFID read/write device
Modelname / HVIN: *	TN902-Q175L200-H1147
FCC ID:*	YQ7TN902-Q175L201
IC: *	8821A-T902Q17L21
Serial number: *	40002
PCB identifier: *	07396901
Hardware version: *	V2.01
Software version: *	V1.52
Lowest internal frequency	16 MHz

1.5 Technical data of equipment

Channel 1	RX:	902.75 MHz	TX:	902.75 MHz
Channel 25	RX:	914.75 MHz	TX:	914.75 MHz
Channel 50	RX:	927.25 MHz	TX:	927.25 MHz

Rated RF output power: *	29 dBm				
Antenna type: *	Internal				
Antenna gain: *	6 dBi				
Antenna connector: *	Yes (internal only)				
Adaptive frequency agility: *	No				
Modulation: *	FHSS (PR-ASK)				
Supply Voltage: *	U _{nom} =	24.0 V DC	U _{min} =	9.6 V DC	U _{max} = 30.0 V DC
Temperature range: *	-20 °C to +70 °C				
Ancillary used for test:	An USB/RS485 converter type SNG 3 was used to connect the EUT to the power supply and the laptop computer. During the conducted emission measurement on the AC-supply line an AC / DC adaptor type FW3288 was used.				

* declared by the applicant.

The following external I/O cables were used:

Identification	Connector		Length *
	EUT	Ancillary	
Power / RS485	4-pin M12-connector	-	2.0 m
-	-	-	-

*: Length during the test if no other specified.

1.6 Dates

Date of receipt of test sample:	07/13/2015
Start of test:	08/18/2015
End of test:	08/25/2015

2 Operational states

All tests were carried out with an unmodified sample.

During all tests the TN902-Q175L200-H1147 was powered by an external power supply with 24.0 V DC.

The operation mode could be chosen with the help of a laptop computer with a test-software, which communicates with the EUT via the RS485 line. The RS485 connection between the laptop PC and the EUT (via the USB/RS485 converter) was maintained during all tests.

The conducted measurements were carried out at the internal antenna connector of the EUT.

The following test modes were adjusted during the tests:

Test items	Operation	Operation mode
20 dB bandwidth	Transmit with normal modulation on channel 1, 25 or 50	1, 2, 3
Carrier frequency separation	Transmit with normal modulation on channel 1, 25 or 50	1, 2, 3
Number of hopping channels	Transmit with normal modulation, hopping on all channels	4
Dwell time	Transmit with normal modulation on channel 1, 25 or 50	1, 2, 3
Maximum peak output power	Transmit with normal modulation on channel 1, 25 or 50	1, 2, 3
Radiated emissions (transmitter)	Transmit with normal modulation on channel 1, 25 or 50	1, 2, 3
Conducted emissions on supply line	Transmit with normal modulation, hopping on all channels	4

Physical boundary of the EUT

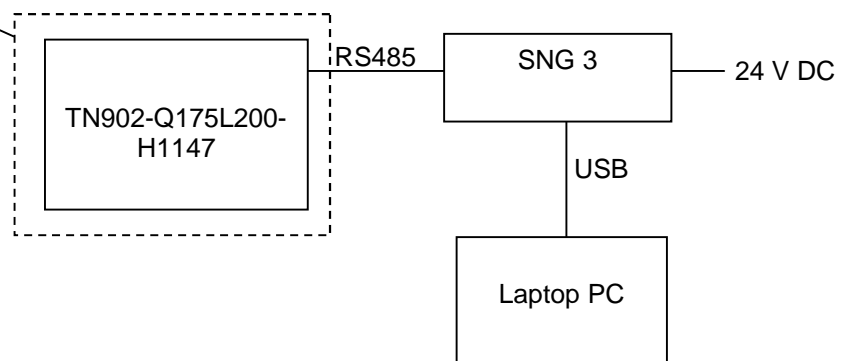

3 Additional information

During the tests the EUT was not labelled as required by FCC / IC.

4 Overview

Application	Frequency range [MHz]	FCC 47 CFR Part 15 section [2]	RSS 247, Issue 1 [3] or RSS-Gen, Issue 4 [4]	Status	Refer page
20 dB bandwidth	General	15.247 (a) (1) (i)	5.1 (1) [3]	Passed	8 et seq.
Carrier frequency separation	General	15.247 (a) (1) (i)	5.1 (2) [3]	Passed	11 et seq.
Number of hopping channels	902.0 – 928.0	15.247 (a) (1) (i)	5.1 (3) [3]	Passed	14 et seq.
Dwell time	902.0 – 928.0	15.247 (a) (1) (i)	5.1 (3) [3]	Passed	16 et seq.
Maximum peak output power	902.0 – 928.0	15.247 (b) (2)	5.4 (1) [3]	Passed	18 et seq.
Radiated emissions (transmitter)	0.009 - 10,000	15.247 (d) 15.205 (a) 15.209 (a)	5.5 [3] 8.9 [4]	Passed	21 et seq.
Conducted emissions on supply line	0.15 - 30	15.207 (a)	8.8 [4]	Passed	43 et seq.
Radiated emissions (receiver)	30 - 5,000	15.109 (a)	6.1 [4]	N. a. *	-
Antenna requirement	-	15.203 [2]	-	Passed**	-

*: No measurement of the receiver spurious emissions was carried out, because of a continuously operating co-located transmitter.

** : Integrated antenna only, requirement fulfilled.

5 Test results

5.1 20 dB bandwidth

5.1.1 Method of measurement (20 dB bandwidth)

The calibration of the spectrum analyser has to be checked with the help of a known signal from a signal generator. The EUT has to be connected to the spectrum analyser via a low loss cable. If the EUT is not equipped with an antenna connector, a temporary antenna connector has to be installed. The EUT has to be switched on and the hopping function has to be disabled, the transmitter shall work with its maximum data rate.

The following spectrum analyser settings according to [5] shall be used:

- Span: App. 2 to 3 times the 20 dB bandwidth, centred on the actual hopping channel.
- Resolution bandwidth: $\geq 1\%$ of the 20 dB bandwidth.
- Video bandwidth: \geq the resolution bandwidth.
- Sweep: Auto.
- Detector function: peak.
- Trace mode: Max hold.

After trace stabilisation the marker shall be set on the signal peak. The first display line has to be set on this value. The second display line has to be set 20 dB below the first line (or the peak marker). The frequency lines shall be set on the intersection points between the second display line and the measured curve.

The measurement will be performed at the upper, the lower end and the middle of the assigned frequency band.

Test set-up:



5.1.2 Test results (20 dB bandwidth)

Ambient temperature	21 °C	Relative humidity	58 %
---------------------	-------	-------------------	------

153143_23.wmf: 20 dB bandwidth at the lower end of the assigned frequency band:

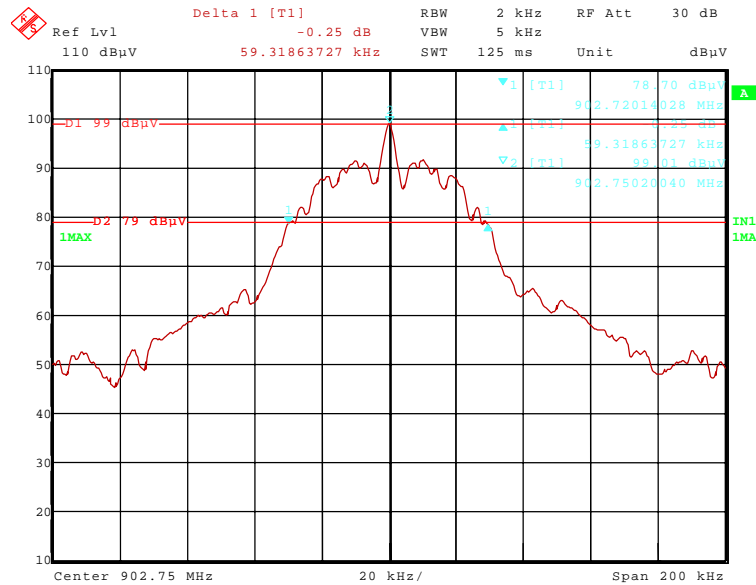

153143_22.wmf: 20 dB bandwidth at the middle of the assigned frequency band:

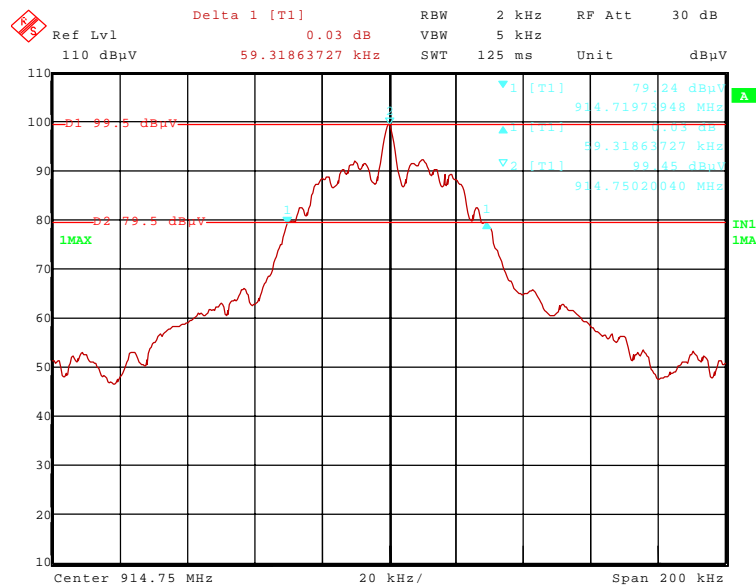

5.2 Carrier frequency separation

5.2.1 Method of measurement (carrier frequency separation)

The calibration of the spectrum analyser has to be checked with the help of a known signal from a signal generator. The EUT has to be connected to the spectrum analyser via a low loss cable. If the EUT is not equipped with an antenna connector, a temporary antenna connector has to be installed. The EUT has to be switched on and the hopping function has to be enabled.

The following spectrum analyser settings according to [5] shall be used:

- Span: Wide enough to capture the peaks of two adjacent channels.
- Resolution bandwidth: $\geq 1\%$ of the span.
- Video bandwidth: \geq the resolution bandwidth.
- Sweep: Auto.
- Detector function: peak.
- Trace mode: Max hold.

After trace stabilisation the marker and the delta marker function will be used to determine the separation between the peaks of two adjacent channel signals.

The measurement will be performed at the upper, the lower end and the middle of the assigned frequency band.

Test set-up:



5.2.2 Test results (carrier frequency separation)

Ambient temperature	21 °C	Relative humidity	58 %
---------------------	-------	-------------------	------

153143_24.wmf: Channel separation at the lower end of the assigned frequency band:

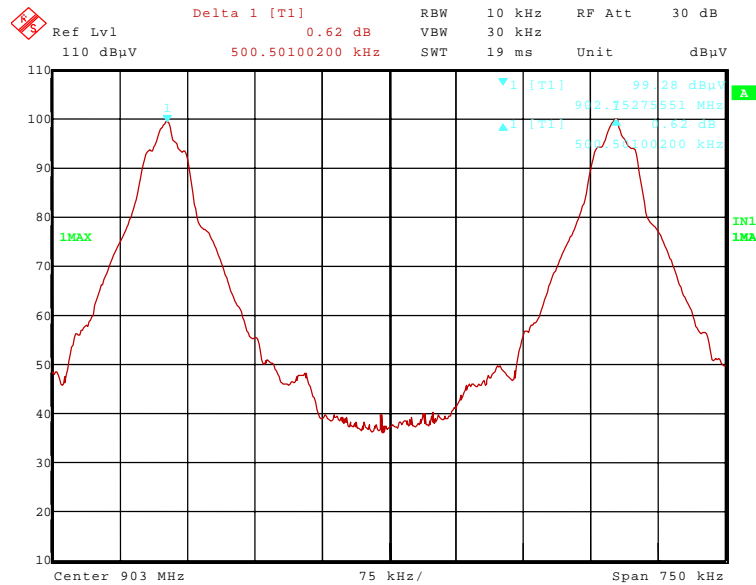

153143_25.wmf: Channel separation at the middle of the assigned frequency band:

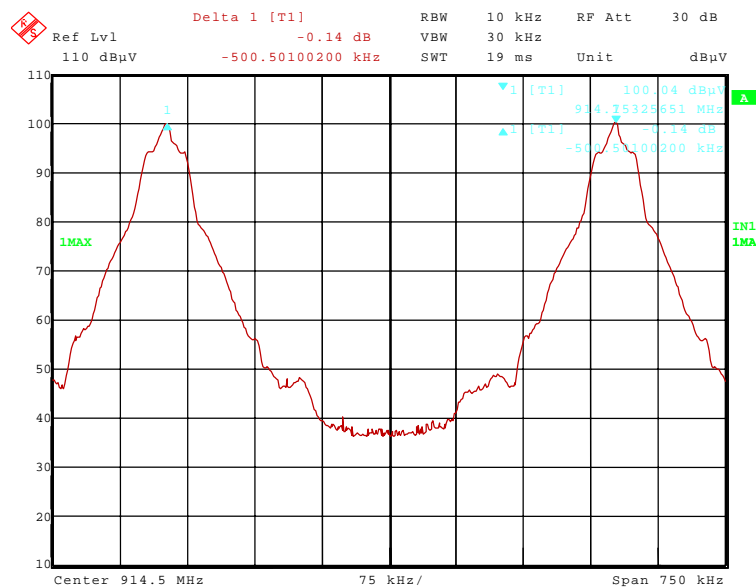

153143 .wmf: Channel separation at the upper end of the assigned frequency band:

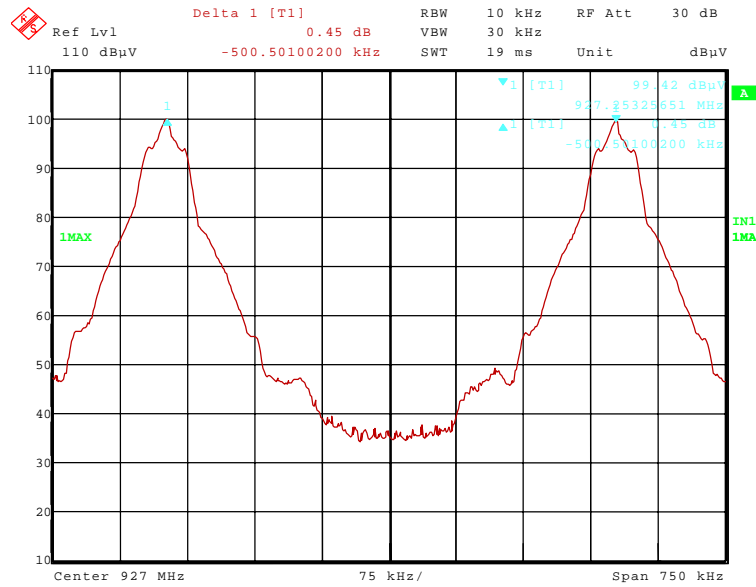

Channel number	Channel frequency [MHz]	Channel separation [kHz]	Minimum limit [kHz]
1	902.750	500.501	59.319 (the 20 dB bandwidth)
25	914.750	500.501	59.319 (the 20 dB bandwidth)
50	927.250	500.501	59.719 (the 20 dB bandwidth)
Measurement uncertainty			<10 ⁻⁷

Test: Passed

Test equipment used (see chapter 6):

31, 54, 84

5.3 Number of hopping frequencies

5.3.1 Method of measurement (number of hopping frequencies)

The calibration of the spectrum analyser has to be checked with the help of a known signal from a signal generator. The EUT has to be connected to the spectrum analyser via a low loss cable. If the EUT is not equipped with an antenna connector, a temporary antenna connector has to be installed. The EUT has to be switched on and the hopping function has to be enabled.

The following spectrum analyser settings according to [5] shall be used:

- Span: Equal to the assigned frequency band.
- Resolution bandwidth: $\geq 1\%$ of the span.
- Video bandwidth: \geq the resolution bandwidth.
- Sweep: Auto.
- Detector function: Peak.
- Trace mode: Max hold.

After trace stabilisation the number of hopping channels could be counted. It might be possible to divide the span into some sub ranges in order to clearly show all hopping frequencies.

Test set-up:



5.3.2 Test results (number of hopping frequencies)

Ambient temperature	21 °C	Relative humidity	58 %
---------------------	-------	-------------------	------

153143 1.wmf: Number of hopping channels:

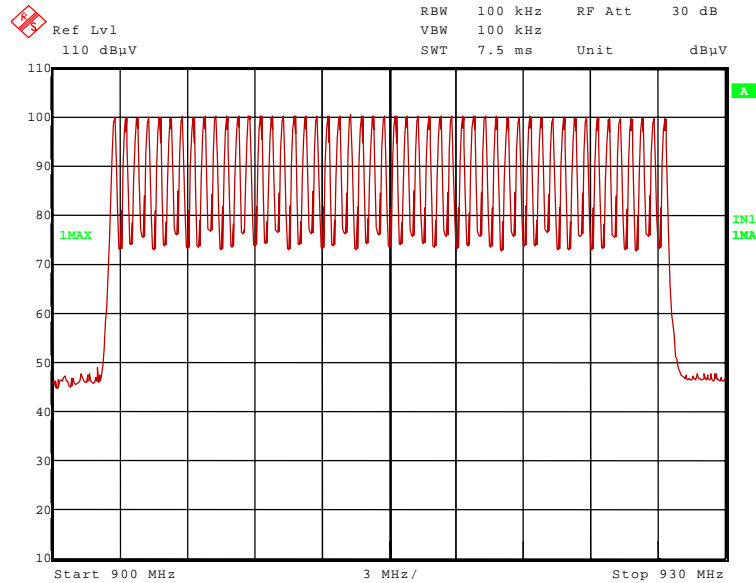

Remark: A smaller Resolution bandwidth was used in order to receive a better optical separation of the signal peaks.

Number of hopping channels	Limit
Operation mode 4	
50	At least 50

Test: Passed

Test equipment used (see chapter 6):

31, 54, 84

5.4 Dwell time

5.4.1 Method of measurement (dwell time)

The calibration of the spectrum analyser has to be checked with the help of a known signal from a signal generator. The EUT has to be connected to the spectrum analyser via a low loss cable. If the EUT is not equipped with an antenna connector, a temporary antenna connector has to be installed. The EUT has to be switched on and the hopping function has to be enabled.

The following spectrum analyser settings according to [5] shall be used:

- Span: Zero, centred on a hopping channel.
- Resolution bandwidth: 1 MHz.
- Video bandwidth: \geq the resolution bandwidth.
- Sweep: As necessary to capture the entire dwell time per hopping channel.
- Detector function: peak.
- Trace mode: Max hold.

The marker and delta marker function of the spectrum analyser will be used to determine the dwell time.

The measurement will be performed at the middle of the assigned frequency band.

If the EUT is possible to operate with different mode of operation (data rates, modulation formats etc.) the test will be repeated with every different operation mode of the EUT.

Test set-up:



5.4.2 Test results (dwell time)

Ambient temperature	21 °C	Relative humidity	58 %
---------------------	-------	-------------------	------

153143_27.wmf: Dwell time at the middle of the assigned frequency band:

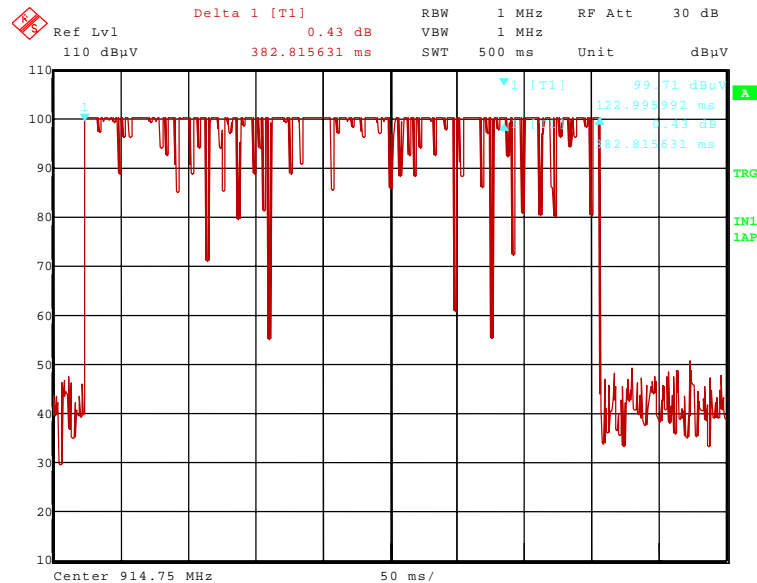

The dwell time is calculated with the following formula:

$$\text{Dwell time} = t_{\text{pulse}} \times n_{\text{hops}} / \text{number of hopping channels} \times 20 \text{ s}$$

Where:

t_{pulse} is the measured pulse time (pls. refer the plots of the spectrum analyser above) [s],
 n_{hops} is the number of hops per second in the actual operating mode of the transmitter [1/s].

The hopping rate of the system is 2.5 hops per second and the system uses 50 channels.

Channel number	Channel frequency [MHz]	t_{pulse} [ms]	Dwell time [ms]	Limit [ms]
25	914.750	382.816	382.816	400.000
Measurement uncertainty			<10 ⁻⁷	

Test: Passed

Test equipment used (see chapter 6):

31, 54, 84

5.5 Maximum peak output power

5.5.1 Method of measurement (maximum peak output power)

The calibration of the spectrum analyser has to be checked with the help of a known signal from a signal generator. The EUT has to be connected to the spectrum analyser via a low loss cable. If the EUT is not equipped with an antenna connector, a temporary antenna connector has to be installed. The EUT has to be switched on and the hopping function has to be disabled.

The following spectrum analyser settings according to [5] shall be used:

- Span: Approx. 5 times the 20 dB bandwidth, centred on a hopping channel.
- Resolution bandwidth: > the 20 dB bandwidth of the emission being measured.
- Video bandwidth: \geq the resolution bandwidth.
- Sweep: Auto.
- Detector function: peak.
- Trace mode: Max hold.

After trace stabilisation the marker shall be set on the signal peak. The indicated level is the peak output power, which has to be corrected with the value of the cable loss and an external attenuation (if necessary).

The measurement will be performed at the upper and lower end and the middle of the assigned frequency band.

Test set-up:



5.5.2 Test results (maximum peak output power)

Ambient temperature	22 °C	Relative humidity	54 %
---------------------	-------	-------------------	------

153143 28.wmf: Maximum peak output power at the lower end of the assigned frequency band:

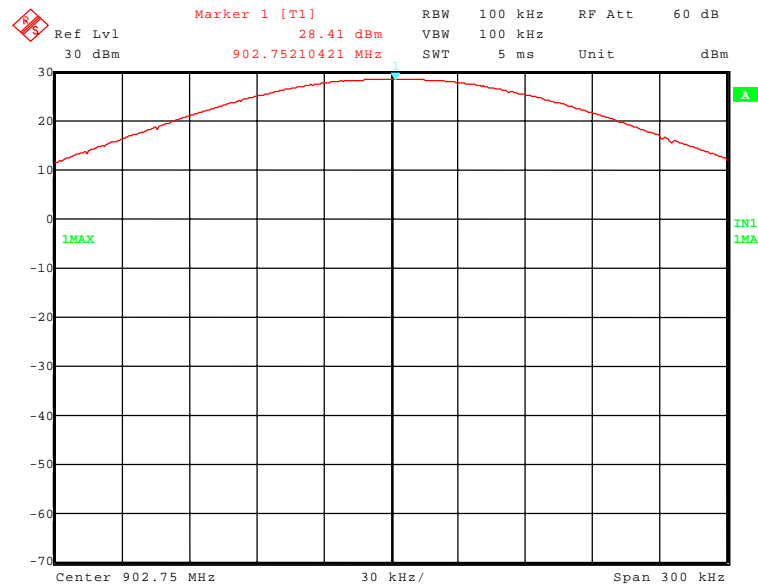

153143 29.wmf: Maximum peak output power at the middle of the assigned frequency band:

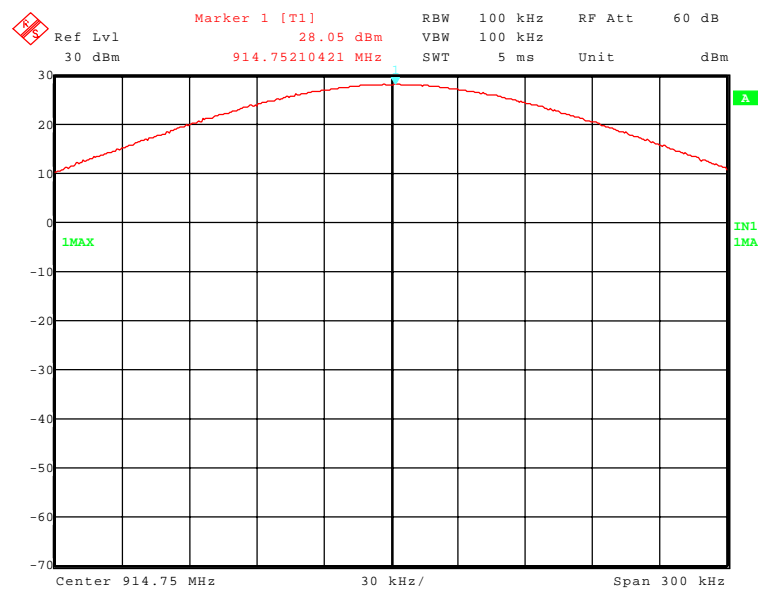

153143_30.wmf: Maximum peak output power at the upper end of the assigned frequency band:

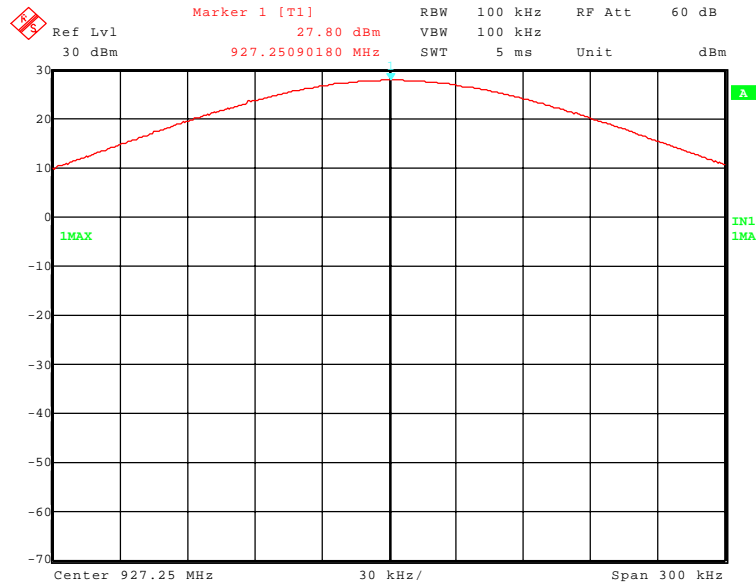

Operation mode	Channel number	Channel frequency [MHz]	Maximum peak output power [dBm]	Antenna gain [dBi]	Peak power limit [dBm]
1	1	902.750	28.41	6.0	30.0
2	25	914.750	28.05	6.0	30.0
3	50	927.250	27.80	6.0	30.0
Measurement uncertainty				+0.66 dB / -0.72 dB	

Test: Passed

Test equipment used (see chapter 6):

31, 54, 84

5.6 Radiated emissions

5.6.1 Method of measurement (radiated emissions)

The radiated emission measurement is subdivided into five stages.

- A preliminary measurement carried out in a fully anechoic chamber with a fixed antenna height in the frequency range 9 kHz to 1 GHz.
- A final measurement carried out on an outdoor test site without reflecting ground plane and a fixed antenna height in the frequency range 9 kHz to 30 MHz.
- A final measurement carried out on an open area test site with reflecting ground plane and various antenna height in the frequency range 30 MHz to 1 GHz.
- A preliminary measurement carried out in a fully anechoic chamber with a variable antenna distance and height in the frequency range 1 GHz to 25 / 40 GHz.
- A final measurement carried out in a fully anechoic chamber with a fixed antenna height in the frequency range 1 GHz to 40 GHz.

Preliminary measurement (9 kHz to 30 MHz):

In the first stage a preliminary measurement will be performed in a shielded room with a measuring distance of 3 meters. Table-top devices will set up on a non-conducting support with a size of 1 m by 1.5 m and a height of 80 cm. Floor-standing devices will be placed directly on the turntable/ground plane. The set up of the Equipment under test will be in accordance to [1].

The frequency range 9 kHz to 30 MHz will be monitored with a spectrum analyser while the system and its cables will be manipulated to find out the configuration with the maximum emission levels if applicable. The EMI Receiver will be set to MAX Hold mode. The EUT and the measuring antenna will be rotated around their vertical axis to found the maximum emissions.

The resolution bandwidth of the spectrum analyser will be set to the following values:

Frequency range	Resolution bandwidth
9 kHz to 150 kHz	200 Hz
150 kHz to 30 MHz	10 kHz

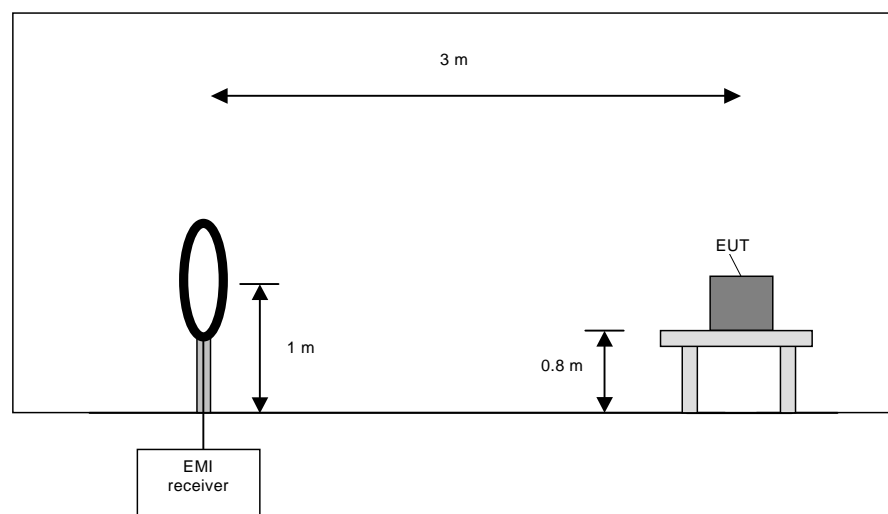

Preliminary measurement procedure:

Prescans were performed in the frequency range 9 kHz to 150 kHz and 150 kHz to 30 MHz.

The following procedure will be used:

- 1) Monitor the frequency range at horizontal polarisation and a EUT azimuth of 0 °.
- 2) Manipulate the system cables within the range to produce the maximum level of emission.
- 3) Rotate the EUT by 360 ° to maximize the detected signals.
- 4) Make a hardcopy of the spectrum.
- 5) Measure the frequencies of highest detected emission with a lower span and resolution bandwidth to increase the accuracy and note the frequency value.
- 6) Repeat steps 1) to 5) with the other orthogonal axes of the EUT (because of EUT is a module and might be used in a handheld equipment application).
- 7) Rotate the measuring antenna and repeat steps 1) to 5).

Final measurement (9 kHz to 30 MHz):

In the second stage a final measurement will be performed on an open area test site with no conducting ground plane in a measuring distances of 3 m, 10 m and 30 m. In the case where larger measuring distances are required the results will be extrapolated based on the values measured on the closer distances according to Section 15.31 (f) (2) [2]. The final measurement will be performed with a EMI Receiver set to Quasi Peak detector except for the frequency bands 9 kHz to 90 kHz and 110 kHz to 490 kHz where an average detector will be used according Section 15.209 (d) [2].

On the frequencies, which were detected during the preliminary measurements, the final measurement will be performed while rotating the EUT and the measuring antenna in the range of 0 ° to 360 ° around their vertical axis until the maximum value is found.

The resolution bandwidth of the EMI Receiver will be set to the following values:

Frequency range	Resolution bandwidth
9 kHz to 150 kHz	200 Hz
150 kHz to 30 MHz	9 kHz

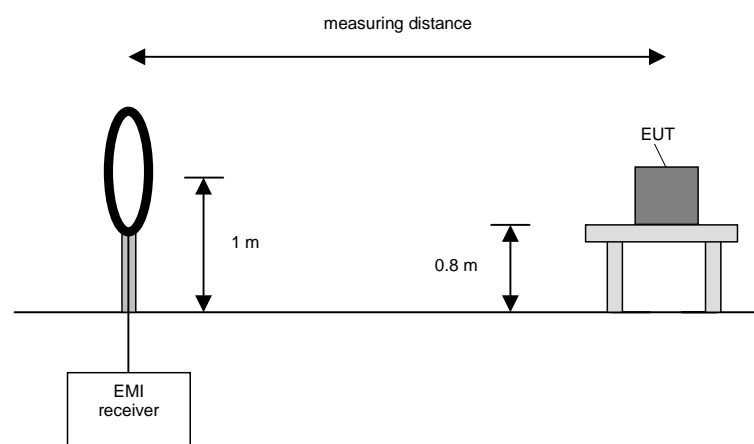

Final measurement procedure:

The following procedure will be used:

- 1) Monitor the frequency range with the measuring antenna at vertical orientation parallel to the EUT at an azimuth of 0 °.
- 2) Rotate the EUT by 360 ° to maximize the detected signals and note the azimuth and orientation.
- 3) Rotate the measuring antenna to find the maximum and note the value.
- 4) Rotate the measuring antenna and repeat steps 1) to 3) until the maximum value is found.
- 5) Repeat steps 1) to 4) with the other orthogonal axes of the EUT (if the EUT is a module and might be used in a handheld equipment application).

Preliminary measurement (30 MHz to 1 GHz)

In the first stage a preliminary measurement will be performed in a fully anechoic chamber with a measuring distance of 3 meter. Table top devices will set up on a non-conducting turn device on the height of 1.5 m. Floor-standing devices will be placed directly on the turntable/ground plane. The set up of the Equipment under test will be in accordance to [1].

The frequency range 30 MHz to 1 GHz will be measured with an EMI Receiver set to MAX Hold mode and a resolution bandwidth of 100 kHz. The measurement will be performed in horizontal and vertical polarisation of the measuring antenna and while rotating the EUT in its vertical axis in the range of 0 ° to 360 °. This measurement is repeated after raising the EUT in 30 ° steps according 6.6.5.4 in [1].

The resolution bandwidth of the EMI Receiver will be set to the following values:

Frequency range	Resolution bandwidth
30 MHz to 230 MHz	100 kHz
230 MHz to 1 GHz	100 kHz

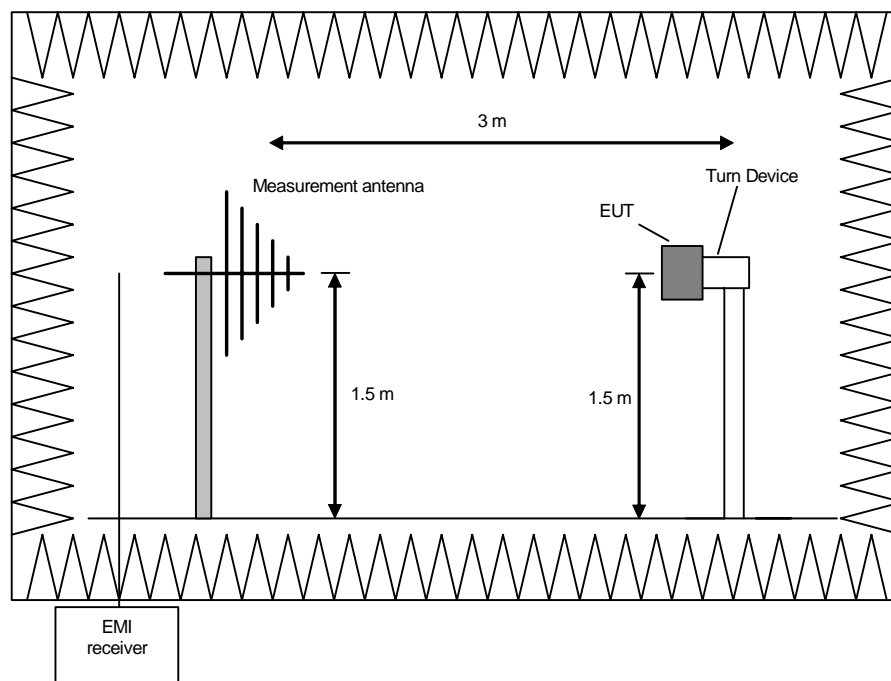

Procedure preliminary measurement:

Prescans were performed in the frequency range 30 MHz to 230 MHz and 230 MHz to 1 GHz.

The following procedure will be used:

1. Monitor the frequency range at horizontal polarisation and a EUT azimuth of 0 °.
2. Manipulate the system cables within the range to produce the maximum level of emission.
3. Rotate the EUT by 360 ° to maximize the detected signals.
4. Repeat 1) to 3) with the vertical polarisation of the measuring antenna.
5. Make a hardcopy of the spectrum.
6. Repeat 1) to 5) with the EUT raised by an angle of 30 ° (60 °, 90 °, 120 ° and 150 °) according to 6.6.5.4 in [1].
7. Measure the frequency of the detected emissions with a lower span and resolution bandwidth to increase the accuracy and note the frequency value.

Final measurement (30 MHz to 1 GHz)

A final measurement on an open area test site will be performed on selected frequencies found in the preliminary measurement. During this test the EUT will be rotated in the range of 0 ° to 360 °, the measuring antenna will be set to horizontal and vertical polarisation and raised and lowered in the range from 1 m to 4 m to find the maximum level of emissions.

The resolution bandwidth of the EMI Receiver will be set to the following values:

Frequency range	Resolution bandwidth
30 MHz to 1 GHz	120 kHz

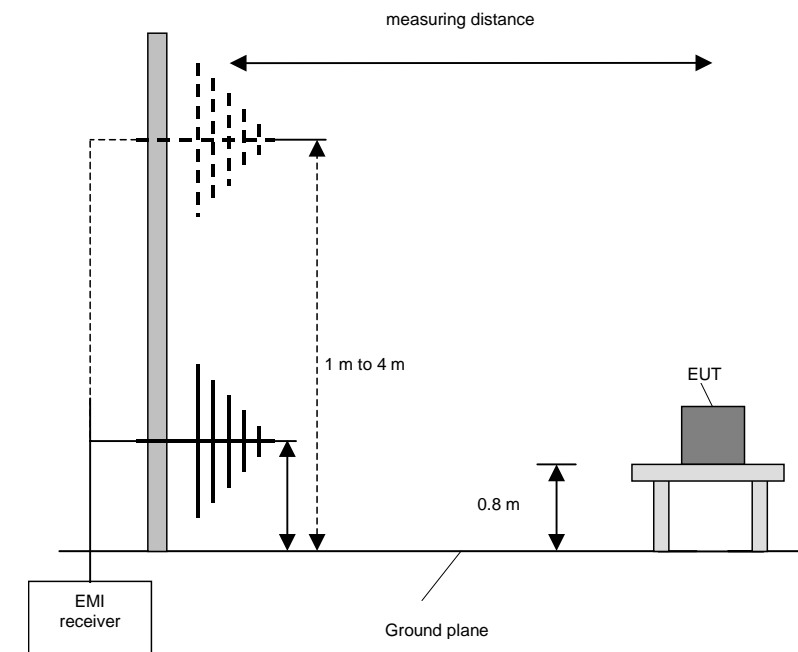

Procedure final measurement:

The following procedure will be used:

- 1) Measure on the selected frequencies at an antenna height of 1 m and a EUT azimuth of 23 °.
- 2) Move the antenna from 1 m to 4 m and note the maximum value at each frequency.
- 3) Rotate the EUT by 45 ° and repeat 2) until an azimuth of 337 ° is reached.
- 4) Repeat 1) to 3) for the other orthogonal antenna polarization.
- 5) Move the antenna and the turntable to the position where the maximum value is detected.
- 6) Measure while moving the antenna slowly +/- 1 m.
- 7) Set the antenna to the position where the maximum value is found.
- 8) Measure while moving the turntable +/- 45 °.
- 9) Set the turntable to the azimuth where the maximum value is found.
- 10) Measure with Final detector (QP and AV) and note the value.
- 11) Repeat 5) to 10) for each frequency.
- 12) Repeat 1) to 11) for each orthogonal axes of the EUT (because of EUT is a module and might be used in a handheld equipment application).

Preliminary and final measurement (1 GHz to 40 GHz)

This measurement will be performed in a fully anechoic chamber. Table top devices will set up on a non-conducting turn device on the height of 1.5 m. The set-up of the Equipment under test will be in accordance to [1].

Preliminary measurement (1 GHz to 40 GHz)

The frequency range will be divided into different sub ranges depending of the frequency range of the used horn antenna. The spectrum analyser set to MAX Hold mode and a resolution bandwidth of 100 kHz. The measurement will be performed in horizontal and vertical polarisation of the measuring antenna and while rotating the EUT in its vertical axis in the range of 0 ° to 360 °. This measurement is repeated after raising the EUT in 30 ° steps according 6.6.5.4 in [1].

The resolution bandwidth of the EMI Receiver will be set to the following values:

Frequency range	Resolution bandwidth
1 GHz to 4 GHz	100 kHz
4 GHz to 12 GHz	100 kHz
12 GHz to 18 GHz	100 kHz
18 GHz to 25 / 26.5 GHz	100 kHz
26.5 GHz to 40 GHz	100 kHz

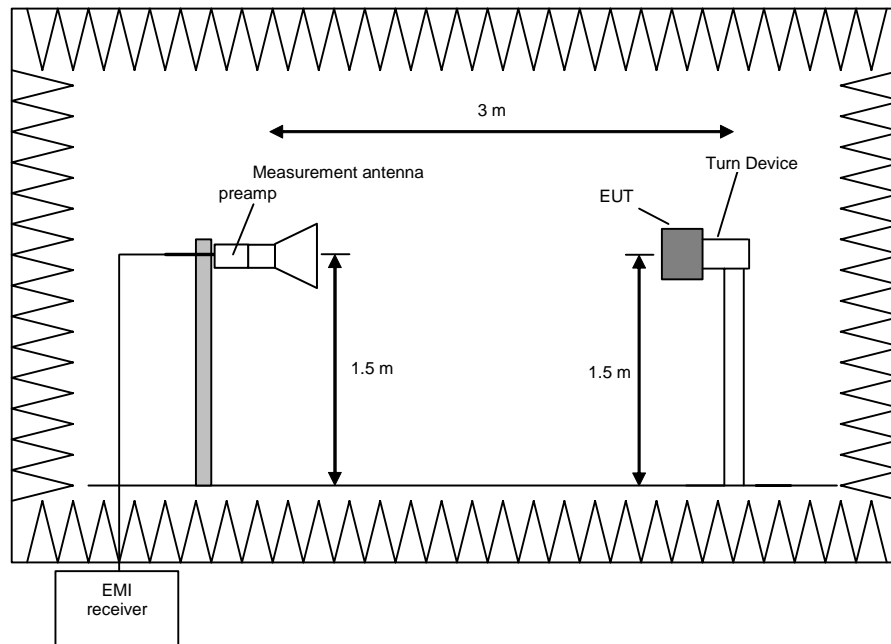

Procedure preliminary measurement:

Prescans were performed in the frequency range 1 to 40 GHz.

The following procedure will be used:

1. Monitor the frequency range at horizontal polarisation and a EUT azimuth of 0 °.
2. Rotate the EUT by 360° to maximize the detected signals.
3. Repeat 1) to 2) with the vertical polarisation of the measuring antenna.
4. Make a hardcopy of the spectrum.
5. Repeat 1) to 4) with the EUT raised by an angle of 30° (60°, 90°, 120° and 150°) according to 6.6.5.4 in [1].
6. Measure the frequency of the detected emissions with a lower span and resolution bandwidth to increase the accuracy and note the frequency value.
7. The measurement antenna polarisation, with the according EUT position (Turntable and Turn device) which produces the highest emission for each frequency will be used for the final measurement. The six closest values to the applicable limit will be used for the final measurement.

Final measurement (1 GHz to 40 GHz)

The frequency range will be divided into different sub ranges depending of the frequency range of the used horn antenna. The EMI Receiver set to peak and average mode and a resolution bandwidth of 1 MHz. The measurement will be performed by rotating the turntable through 0 to 360° in the worst-case EUT orientation which was obtained during the preliminary measurements.

The resolution bandwidth of the EMI Receiver will be set to the following values:

Frequency range	Resolution bandwidth
1 GHz to 4 GHz	1 MHz
4 GHz to 12 GHz	1 MHz
12 GHz to 18 GHz	1 MHz
18 GHz to 25 / 26.5 GHz	1 MHz
26.5 GHz to 40 GHz	1 MHz

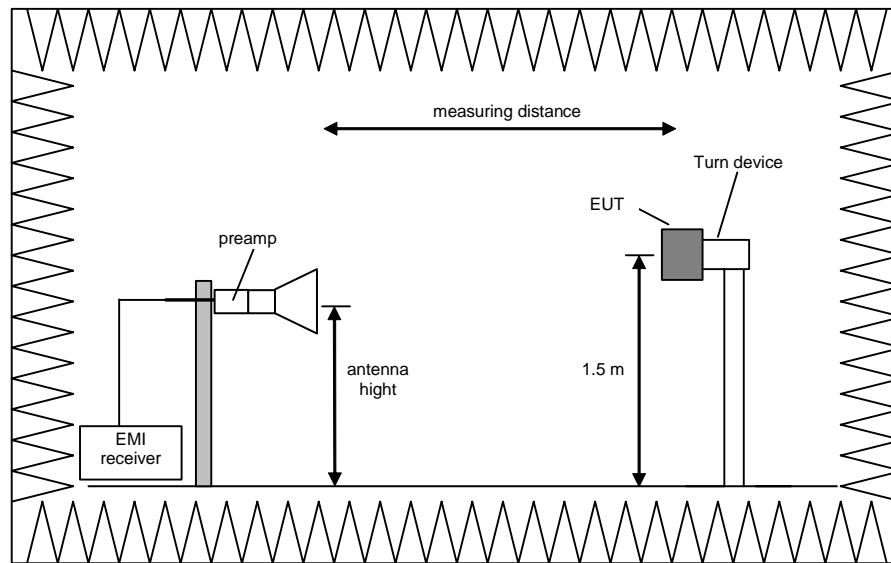

Procedure of measurement:

The measurements were performed in the frequency ranges 1 GHz to 4 GHz, 4 GHz to 12 GHz, 12 GHz to 18 GHz, 18 GHz to 25 /26.5 GHz and 26.5 GHz to 40 GHz.

The following procedure will be used:

- 1) Set the turntable and the turn device to obtain the worst-case emission for the first frequency identified in the preliminary measurements.
- 2) Set the measurement antenna polarisation to the orientation with the highest emission for the first frequency identified in the preliminary measurements.
- 3) Set the spectrum analyser to EMI mode with peak and average detector activated.
- 4) Rotate the turntable from 0° to 360° to find the EUT angle that produces the highest emissions.
- 5) Note the highest displayed peak and average values
- 6) Repeat the steps 1) to 5) for each frequency detected during the preliminary measurements.

5.6.2 Test results (radiated emissions)

5.6.2.1 Preliminary radiated emission measurement

Ambient temperature	21 °C	Relative humidity	58 %
---------------------	-------	-------------------	------

Position of EUT:	The EUT was set-up on a non-conducting table of a height of 0.8 m and 1.5 m. The distance between EUT and antenna was 3 m.
Cable guide:	For detail information of test set-up and the cable guide refer to the pictures in annex A of this test report.
Test record:	All results are shown in the following.
Supply voltage:	During all measurements the EUT was supplied with 24 V DC by an external power supply.
Frequency range:	The preliminary measurement was carried out in the frequency range 10 MHz to 10 GHz according to [2].
Remark:	As pre-tests have shown, the emissions in the frequency range 10 MHz to 30 MHz are not depending on the transmitter operation mode. Therefore the emissions in this frequency range were measured only with the transmitter operates in operation mode 2.

Transmitter operates at the lower end of the assigned frequency band (operation mode 1)

153143_2.wmf: Spurious emissions from 30 MHz to 230 MHz (operation mode 1):

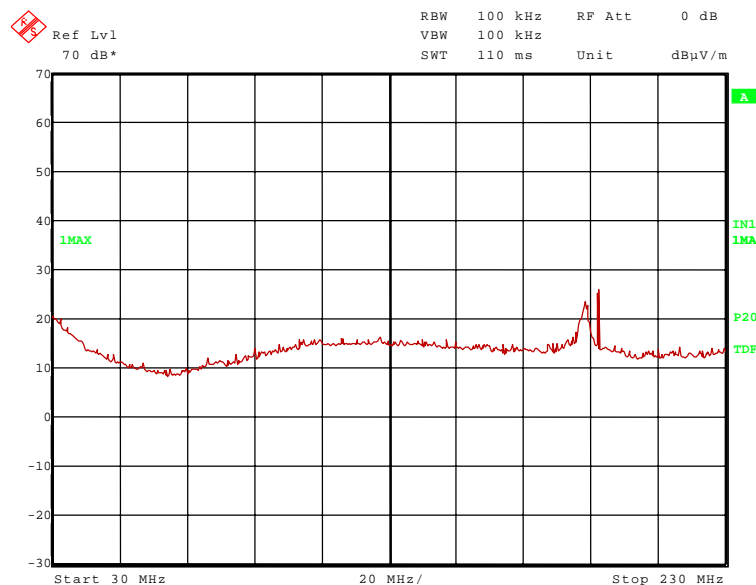

153143_3.wmf: Spurious emissions from 230 MHz to 1 GHz (operation mode 1, carrier notched):

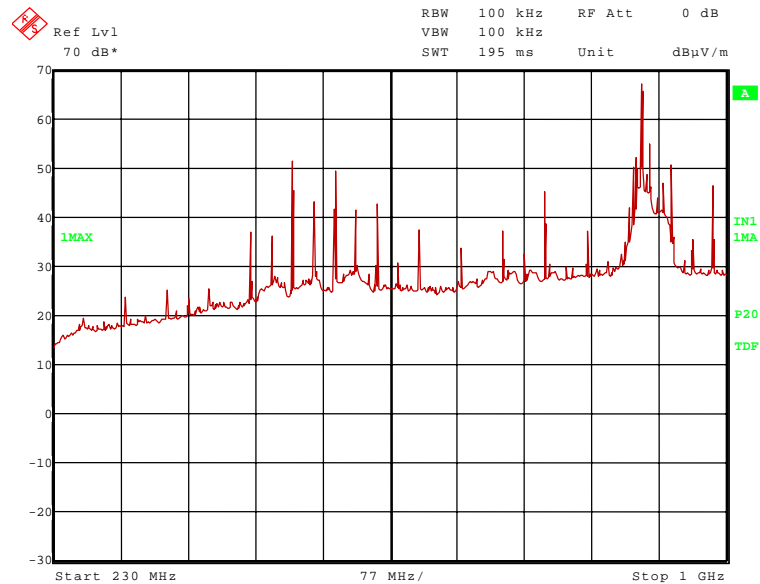

The following frequencies were found outside the restricted bands during the preliminary radiated emission test:

- 188.270 MHz, 192.000 MHz, 455.989 MHz, 503.987 MHz, 551.986 MHz, 599.985 MHz, 791.980 MHz, 897.249 MHz, 902.750 MHz, 912.000 MHz and 935.977 MHz.

The following frequency was found inside the restricted bands during the preliminary radiated emission test:

- 983.975 MHz.

These frequencies have to be measured on the open area test site. The result is presented in the following.

153143_16.wmf: Spurious emissions from 1 GHz to 4 GHz (operation mode 1):

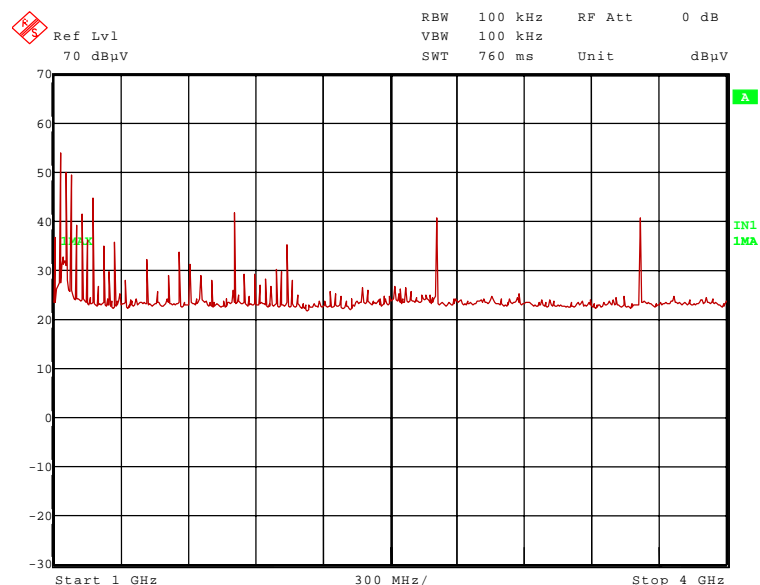

153143_19.wmf: Spurious emissions from 4 GHz to 10 GHz (operation mode 1):

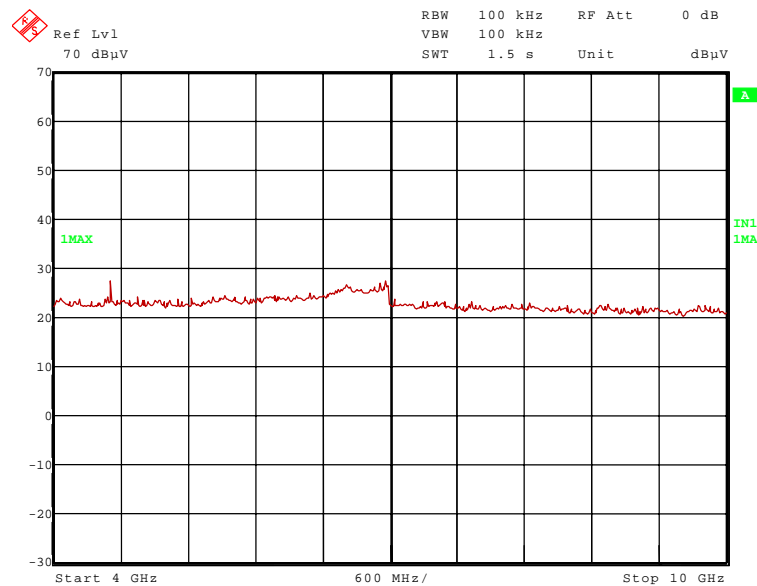

The following frequencies were found inside the restricted bands during the preliminary radiated emission test:

- 1031.974 MHz, 1175.970 MHz, 2708.250 MHz, 3611.000 MHz and 4513.750 MHz.

The following frequency was found outside the restricted bands during the preliminary radiated emission test:

- 1805.500 MHz and 2039.950 MHz.

These frequencies have to be measured in a final measurement. The results were presented in the following.

Test equipment used (see chapter 6):

29, 31 - 36, 43 - 45, 49, 54, 55, 73, 75, 83, 84

153143_5.wmf: Spurious emissions from 230 MHz to 1 GHz (operation mode 2, carrier notched):

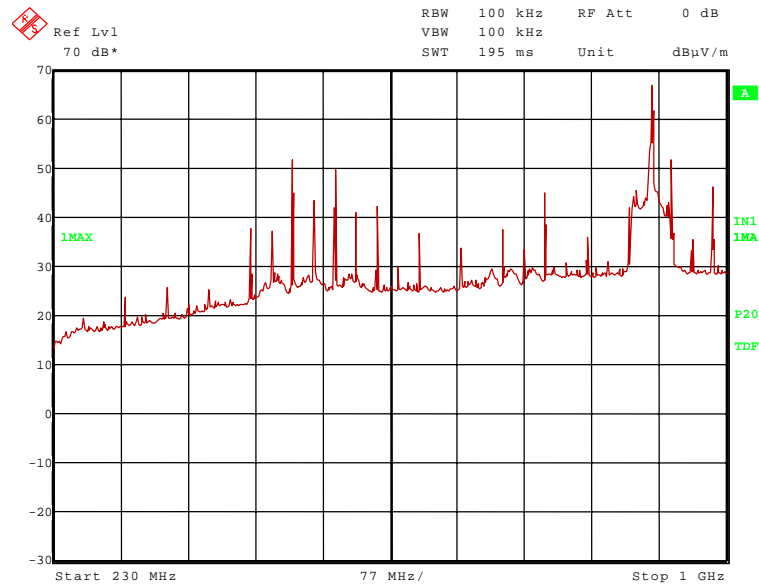

The following frequencies were found outside the restricted bands during the preliminary radiated emission test:

- 188.095 MHz, 192.000 MHz, 455.989 MHz, 503.987 MHz, 551.986 MHz, 599.985 MHz, 791.981 MHz, 896.250 MHz, 914.750 MHz and 936.000 MHz

The following frequency was found inside the restricted bands during the preliminary radiated emission test:

- 983.975 MHz

These frequencies have to be measured on the open area test site. The result is presented in the following.

153143_15.wmf: Spurious emissions from 1 GHz to 4 GHz (operation mode 2):

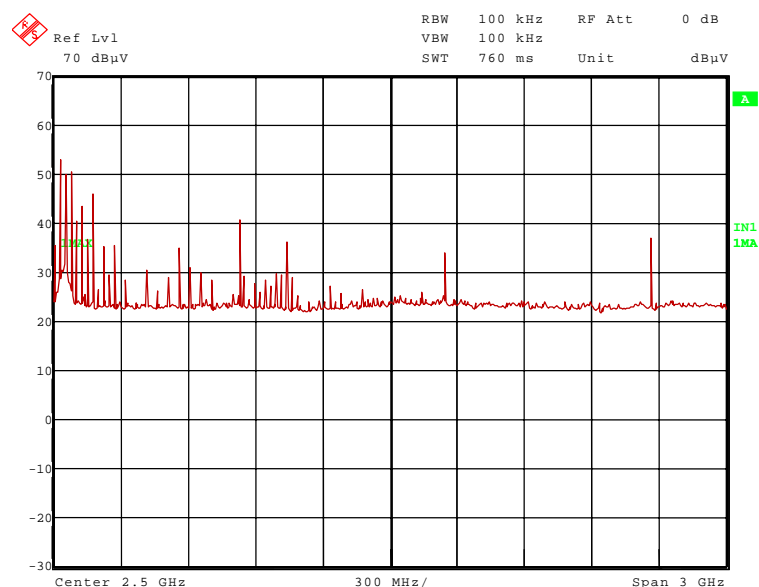

153143_18.wmf: Spurious emissions from 4 GHz to 10 GHz (operation mode 2):

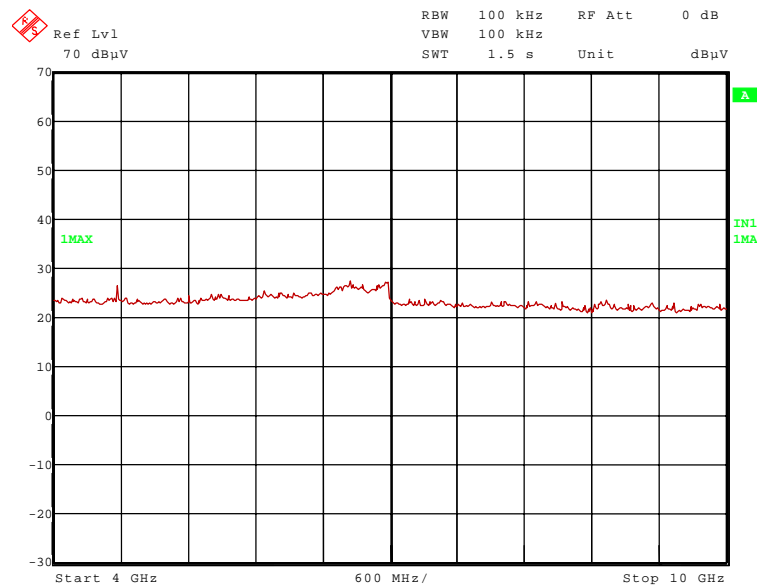

The following frequencies were found inside the restricted bands during the preliminary radiated emission test:

- 1031.974 MHz, 1175.970 MHz, 2744.250 MHz, 3659.000 MHz and 4573.250 MHz.

The following frequency was found outside the restricted bands during the preliminary radiated emission test:

- 1.8295 MHz and 2039.950 MHz.

These frequencies have to be measured in a final measurement. The results were presented in the following.

5.6.2.2 Final radiated emission measurement (30 MHz to 1 GHz)

Ambient temperature	20 °C	Relative humidity	56 %
---------------------	-------	-------------------	------

Position of EUT: The EUT was set-up on a non-conducting table of a height of 0.8 m. The distance between EUT and antenna was 3 m.

Cable guide: For detail information of test set-up and the cable guide refer to the pictures in annex A of this test report.

Test record: All results are shown in the following.

Supply voltage: During all measurements the EUT was supplied with 24 V DC by an external power supply.

Test results: The test results were calculated with the following formula:

$$\text{Result [dB}\mu\text{V/m]} = \text{reading [dB}\mu\text{V]} + \text{cable loss [dB]} + \text{antenna factor [dB/m]}$$

The measured points and the limit line in the following diagrams refer to the standard measurement of the emitted interference in compliance with the above-mentioned standard. The measured points marked with an x are the measured results of the standard final measurement on the open area test site.

The results of the standard subsequent measurement on the open area test site are indicated in the table below. The limits as well as the measured results (levels) refer to the above mentioned standard while taking account of the specified requirements for a 3 m measuring distance.

The measurement time with the quasi-peak measuring detector is 1 second.

Transmitter operates on the lower end of the assigned frequency (operation mode 1)

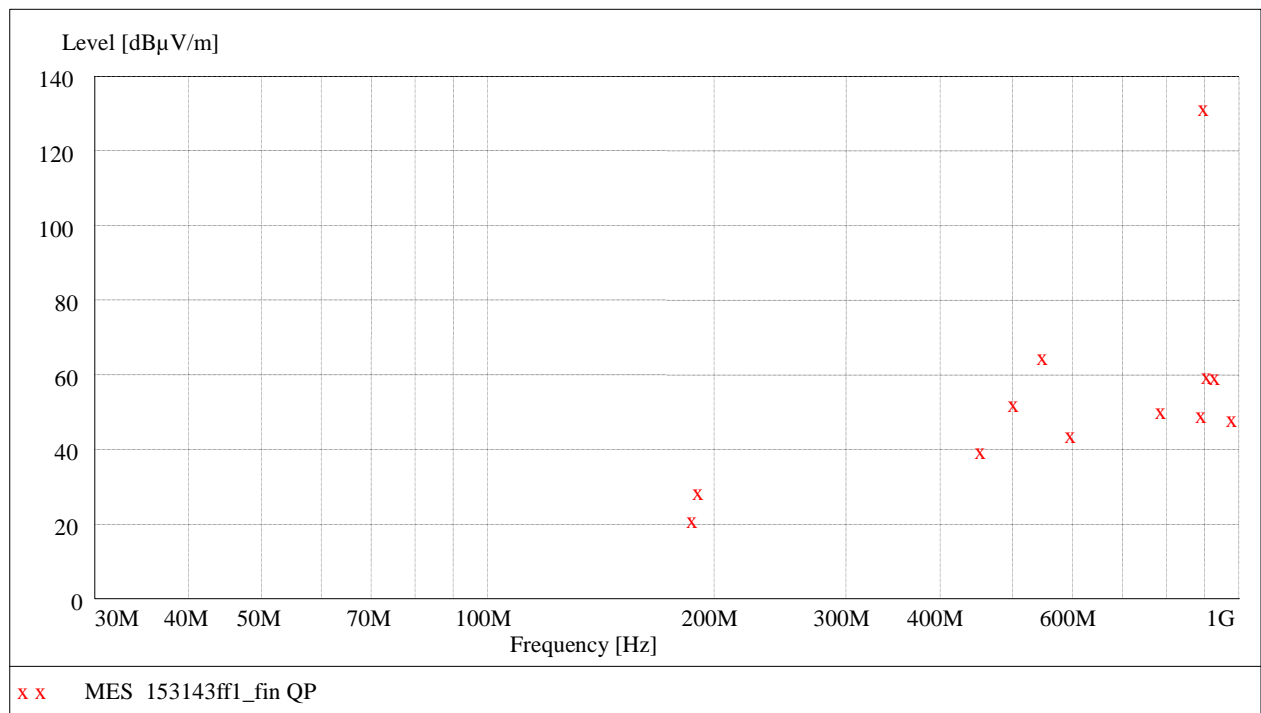

Data record name: 153143ff1

Transmitter operates on the middle of the assigned frequency (operation mode 2)

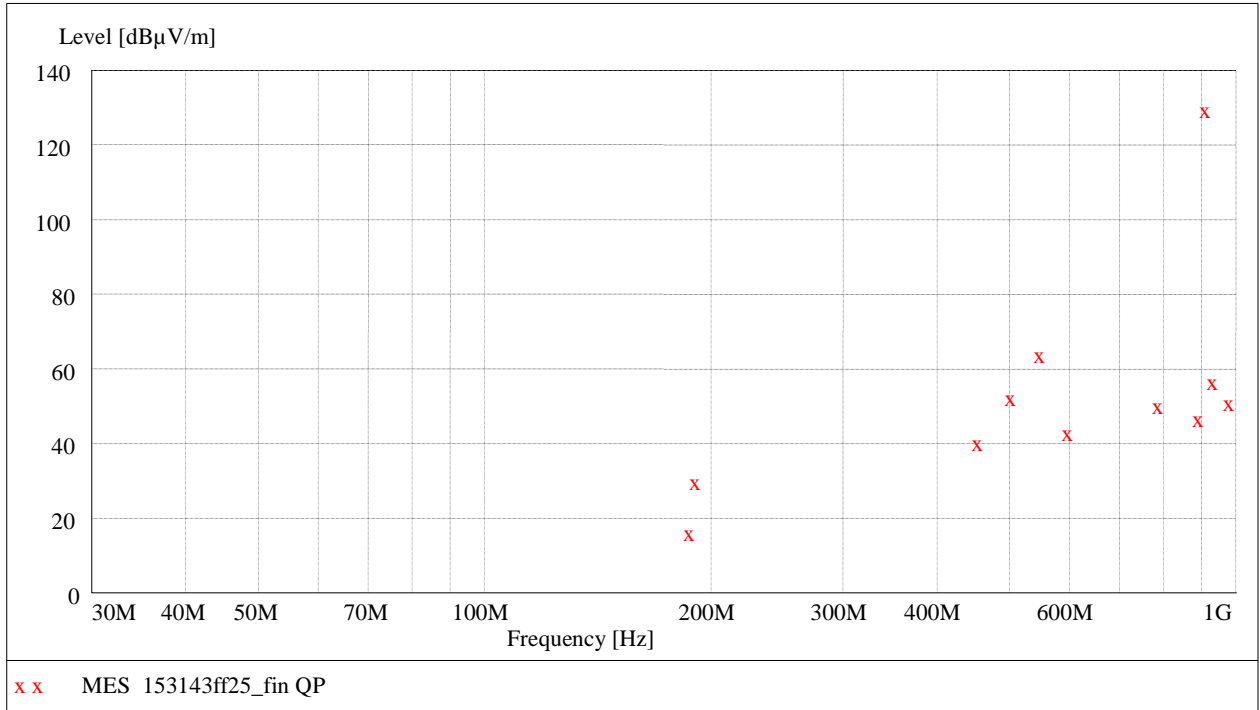

Data record name: 153143ff25

Transmitter operates on the upper end of the assigned frequency (operation mode 3)

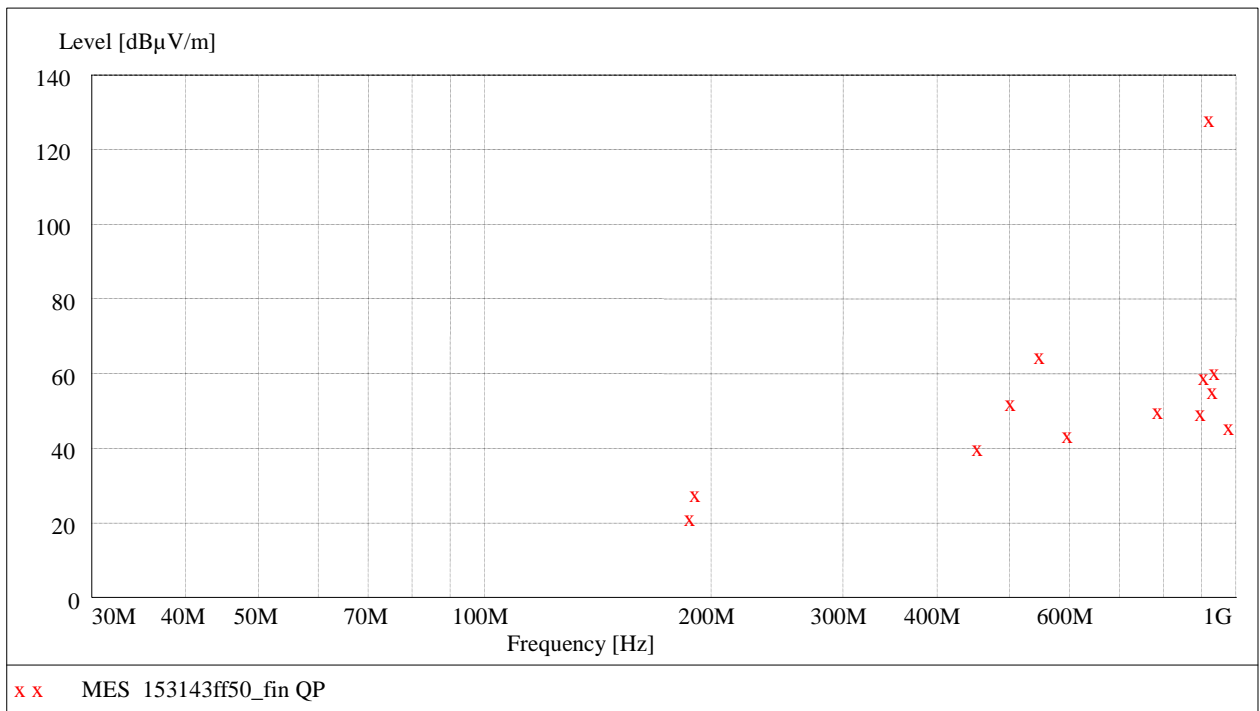

Data record name: 153143ff50

Result measured with the quasi-peak detector:
(These values were marked in the diagrams by an x)

Transmitter operates on the lower end of the assigned frequency band (operation mode 1)									
Spurious emissions outside restricted bands									
Frequency	Result	Limit	Margin	Readings	Antenna factor	Cable loss	Height	Azimuth	Pol.
MHz	dB μ V/m	dB μ V/m	dB	dB μ V	dB/m	dB	cm	deg	
188.270	22.1	112.3	90.2	11.6	9.0	1.5	100	348	Vert.
192.000	29.5	112.3	82.8	19.0	9.0	1.5	110	135	Hor.
455.989	40.4	112.3	71.9	21.3	16.7	2.4	100	0	Vert.
503.987	53.0	112.3	59.3	33.0	17.5	2.5	100	342	Vert.
551.986	65.6	112.3	46.7	43.2	19.7	2.7	100	2	Vert.
599.985	44.7	112.3	67.6	22.7	19.2	2.8	155	9	Vert.
791.980	51.2	112.3	61.1	26.6	21.4	3.2	111	56	Vert.
897.249	50.1	112.3	62.2	24.3	22.3	3.5	100	2	Vert.
902.750	132.3	Carrier	-	106.4	22.5	3.4	174	0	Hor.
912.000	60.5	112.3	51.8	34.4	22.7	3.4	100	0	Vert.
935.977	60.3	112.3	52.0	33.2	23.7	3.4	165	65	Hor.
Spurious emissions inside restricted bands									
Frequency	Result	Limit	Margin	Readings	Antenna factor	Cable loss	Height	Azimuth	Pol.
MHz	dB μ V/m	dB μ V/m	dB	dB μ V	dB/m	dB	cm	deg	
983.975	49.1	54.0	4.9	21.8	23.8	3.5	150	74	Hor.

Transmitter operates on the middle of the assigned frequency band (operation mode 2)									
Spurious emissions outside restricted bands									
Frequency	Result	Limit	Margin	Readings	Antenna factor	Cable loss	Height	Azimuth	Pol.
MHz	dB μ V/m	dB μ V/m	dB	dB μ V	dB/m	dB	cm	deg	
188.095	16.9	110.0	93.1	6.4	9.0	1.5	128	110	Hor.
192.000	30.4	110.0	79.6	19.9	9.0	1.5	108	144	Hor.
455.989	41.0	110.0	69.0	21.9	16.7	2.4	100	34	Vert.
503.987	53.0	110.0	57.0	33.0	17.5	2.5	100	350	Vert.
551.986	64.6	110.0	45.4	42.2	19.7	2.7	100	326	Vert.
599.985	43.8	110.0	66.2	21.8	19.2	2.8	150	15	Vert.
791.981	50.8	110.0	59.2	26.2	21.4	3.2	109	63	Vert.
896.250	47.4	110.0	62.6	21.6	22.3	3.5	172	11	Hor.
914.750	130.0	Carrier	-	103.8	22.8	3.4	100	10	Vert.
936.000	57.1	110.0	52.9	30.0	23.7	3.4	164	68	Hor.
Spurious emissions inside restricted bands									
Frequency	Result	Limit	Margin	Readings	Antenna factor	Cable loss	Height	Azimuth	Pol.
MHz	dB μ V/m	dB μ V/m	dB	dB μ V	dB/m	dB	cm	deg	
983.975	51.7	54.0	2.3	24.4	23.8	3.5	150	57	Hor.

Transmitter operates on the upper end of the assigned frequency band (operation mode 3)									
Spurious emissions outside restricted bands									
Frequency	Result	Limit	Margin	Readings	Antenna factor	Cable loss	Height	Azimuth	Pol.
MHz	dB μ V/m	dB μ V/m	dB	dB μ V	dB/m	dB	cm	deg	
188.678	22.1	109.0	86.9	11.6	9.0	1.5	106	0	Vert.
192.000	28.5	109.0	80.5	18.0	9.0	1.5	100	20	Vert.
455.989	40.9	109.0	68.1	21.8	16.7	2.4	100	34	Hor.
503.987	52.8	109.0	56.2	32.8	17.5	2.5	100	28	Vert.
551.986	65.6	109.0	43.4	43.2	19.7	2.7	100	5	Vert.
599.985	44.2	109.0	64.8	22.2	19.2	2.8	158	18	Vert.
791.980	50.8	109.0	58.2	26.2	21.4	3.2	109	67	Vert.
903.252	50.1	109.0	58.9	24.2	22.5	3.4	100	12	Hor.
912.000	59.8	109.0	49.2	33.7	22.7	3.4	100	11	Hor.
927.250	129.1	Carrier	-	102.3	23.4	3.4	100	8	Hor.
936.000	56.1	109.0	52.9	29.0	23.7	3.4	124	0	Vert.
942.500	61.1	109.0	47.9	33.9	23.8	3.4	175	234	Vert.
Spurious emissions inside restricted bands									
Frequency	Result	Limit	Margin	Readings	Antenna factor	Cable loss	Height	Azimuth	Pol.
MHz	dB μ V/m	dB μ V/m	dB	dB μ V	dB/m	dB	cm	deg	
983.975	46.4	54.0	7.6	19.1	23.8	3.5	107	25	Hor.
Measurement uncertainty				+2.2 dB / -3.6 dB					

Test: Passed

Test equipment used (see chapter 6):

14 – 20, 54, 84

5.6.2.3 Final radiated emission measurement (1 GHz to 10 GHz)

Ambient temperature	21 °C	Relative humidity	58 %
---------------------	-------	-------------------	------

Position of EUT: The EUT was set-up on a non-conducting table of a height of 1.5 m. The distance between EUT and antenna was 3 m.

Cable guide: For detail information of test set-up and the cable guide refer to the pictures in annex A of this test report.

Test record: All results are shown in the following.

Supply voltage: During all measurements the EUT was supplied with 24 V DC by an external power supply.

Resolution bandwidth: For all measurements a resolution bandwidth of 1 MHz was used.

Test results: The test results were calculated with the following formula:

$$\text{Result [dB}\mu\text{V/m]} = \text{reading [dB}\mu\text{V]} + \text{cable loss [dB]} + \text{antenna factor [dB/m]} - \text{preamp [dB]}$$

Transmitter operates at the lower end of the assigned frequency band (operation mode 1)

Result measured with the peak detector:

Frequency MHz	Result dB μ V/m	Limit dB μ V/m	Margin dB	Readings dB μ V	Antenna factor 1/m	Preamp dB	Cable loss dB	Height cm	Pol.	Restr. Band
1031.974	54.5	74.0	19.5	56.0	22.5	25.9	1.9	150	Hor.	Yes
1175.970	49.3	74.0	24.7	49.6	23.6	25.9	2.0	150	Hor.	Yes
1805.500	47.9	112.3	64.4	44.2	27.1	25.9	2.5	150	Hor.	No
2039.950	45.3	112.3	67.0	40.2	28.3	25.9	2.7	150	Vert.	No
2708.250	51.9	74.0	22.1	42.9	31.8	26.1	3.2	150	Vert.	Yes
3611.000	53.8	74.0	20.2	43.0	32.9	25.9	3.7	150	Vert.	Yes
4513.750	48.4	74.0	25.6	34.1	35.3	25.2	4.3	150	Hor.	Yes
Measurement uncertainty							+2.2 dB / -3.6 dB			

Result measured with the average detector:

Frequency MHz	Result dB μ V/m	Limit dB μ V/m	Margin dB	Readings dB μ V	Antenna factor 1/m	Preamp dB	Cable loss dB	Height cm	Pol.	Restr. Band
1031.974	52.9	54.0	1.1	54.4	22.5	25.9	1.9	150	Hor.	Yes
1175.970	44.9	54.0	9.1	45.2	23.6	25.9	2.0	150	Hor.	Yes
1805.500	44.3	112.3	68.0	40.6	27.1	25.9	2.5	150	Hor.	No
2039.950	39.1	112.3	73.2	34.0	28.3	25.9	2.7	150	Vert.	No
2708.250	47.6	54.0	6.4	38.6	31.8	26.1	3.2	150	Vert.	Yes
3611.000	50.3	54.0	3.7	39.5	32.9	25.9	3.7	150	Vert.	Yes
4513.750	39.0	54.0	15.0	24.7	35.3	25.2	4.3	150	Hor.	Yes
Measurement uncertainty							+2.2 dB / -3.6 dB			

Transmitter operates at the middle of the assigned frequency band (operation mode 2)

Result measured with the peak detector:

Frequency MHz	Result dB μ V/m	Limit dB μ V/m	Margin dB	Readings dB μ V	Antenna factor 1/m	Preamp dB	Cable loss dB	Height cm	Pol.	Restr. Band
1031.974	54.1	74.0	19.9	55.6	22.5	25.9	1.9	150	Hor.	Yes
1175.970	49.4	74.0	24.6	49.7	23.6	25.9	2.0	150	Hor.	Yes
1829.500	47.5	110.0	62.5	43.8	27.2	26.1	2.6	150	Hor.	No
2039.950	45.4	110.0	64.6	40.3	28.3	25.9	2.7	150	Vert.	No
2744.250	48.6	74.0	25.4	39.0	31.9	25.6	3.3	150	Vert.	Yes
3659.000	53.3	74.0	20.7	42.2	32.7	25.4	3.8	150	Vert.	Yes
4573.250	46.2	74.0	27.8	32.1	35.3	25.5	4.3	150	Hor.	Yes
Measurement uncertainty								+2.2 dB / -3.6 dB		

Result measured with the average detector:

Frequency MHz	Result dB μ V/m	Limit dB μ V/m	Margin dB	Readings dB μ V	Antenna factor 1/m	Preamp dB	Cable loss dB	Height cm	Pol.	Restr. Band
1031.974	51.9	54.0	2.1	53.4	22.5	25.9	1.9	150	Hor.	Yes
1175.970	44.9	54.0	9.1	45.2	23.6	25.9	2.0	150	Hor.	Yes
1829.500	43.6	110.0	66.4	39.9	27.2	26.1	2.6	150	Hor.	No
2039.950	39.2	110.0	70.8	34.1	28.3	25.9	2.7	150	Vert.	No
2744.250	42.8	54.0	11.2	33.2	31.9	25.6	3.3	150	Vert.	Yes
3659.000	49.0	54.0	5.0	37.9	32.7	25.4	3.8	150	Vert.	Yes
4573.250	34.0	54.0	20.0	19.9	35.3	25.5	4.3	150	Hor.	Yes
Measurement uncertainty								+2.2 dB / -3.6 dB		

Transmitter operates at the upper end of the assigned frequency band (operation mode 3)

Result measured with the peak detector:

Frequency MHz	Result dB μ V/m	Limit dB μ V/m	Margin dB	Readings dB μ V	Antenna factor 1/m	Preamp dB	Cable loss dB	Height cm	Pol.	Restr. Band
1031.974	54.8	74.0	19.2	56.3	22.5	25.9	1.9	150	Hor.	Yes
1175.970	49.4	74.0	24.6	49.7	23.6	25.9	2.0	150	Hor.	Yes
1854.500	48.2	109.1	60.9	44.1	27.2	25.7	2.6	150	Hor.	No
2039.950	45.3	109.1	63.8	40.2	28.3	25.9	2.7	150	Vert.	No
2781.750	45.6	74.0	28.4	36.6	31.7	26.1	3.4	150	Vert.	Yes
3709.000	51.4	74.0	22.6	40.7	32.6	25.7	3.8	150	Vert.	Yes
Measurement uncertainty							+2.2 dB / -3.6 dB			

Result measured with the average detector:

Frequency MHz	Result dB μ V/m	Limit dB μ V/m	Margin dB	Readings dB μ V	Antenna factor 1/m	Preamp dB	Cable loss dB	Height cm	Pol.	Restr. Band
1031.974	53.0	54.0	1.0	54.5	22.5	25.9	1.9	150	Hor.	Yes
1175.970	45.1	54.0	8.9	45.4	23.6	25.9	2.0	150	Hor.	Yes
1854.500	44.8	109.1	64.3	40.7	27.2	25.7	2.6	150	Hor.	No
2039.950	38.8	109.1	70.3	33.7	28.3	25.9	2.7	150	Vert.	No
2781.750	38.5	54.0	15.5	29.5	31.7	26.1	3.4	150	Vert.	Yes
3709.000	43.7	54.0	10.3	33.0	32.6	25.7	3.8	150	Vert.	Yes
Measurement uncertainty							+2.2 dB / -3.6 dB			

Test: Passed

Test equipment used (see chapter 6):

29, 31 - 34, 36, 44, 45, 49, 54, 73, 75, 84

5.7 Conducted emissions on power supply lines (150 kHz to 30 MHz)

5.7.1 Method of measurement

This test will be carried out in a shielded chamber. Tabletop devices will set up on a non-conducting support with a size of 1 m by 1.5 m and a height of 80 cm above the ground plane. Floor-standing devices will be placed directly on the ground plane. The setup of the Equipment under test will be in accordance to [1].

The frequency range 150 kHz to 30 MHz will be measured with an EMI Receiver set to MAX Hold mode with peak and average detector and a resolution bandwidth of 9 kHz. A scan will be carried out on the phase (or plus pole in case of DC powered devices) of the AC mains network. If levels detected 10 dB below the appropriate limit, this emission will be measured with the average and quasi-peak detector on all lines.

Frequency range	Resolution bandwidth
150 kHz to 30 MHz	9 kHz

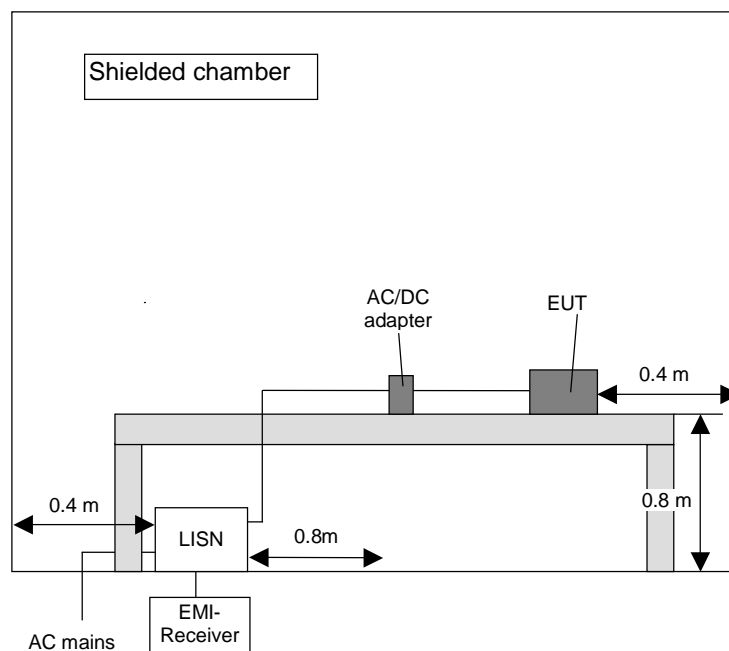

5.7.2 Test results (conducted emissions on power supply lines)

Ambient temperature	21 °C	Relative humidity	64 %
---------------------	-------	-------------------	------

Position of EUT: The EUT was set-up on a non-conducting table of a height of 0.8 m.

Cable guide: The cables of the EUT were fixed on the non-conducting table. For further information of the cable guide refer to the pictures in annex A of this test report.

Test record: All results are shown in the following.

Supply voltage: During this test the EUT was powered with 24 V_{DC} by the Friwo FW3288, which was itself supplied with 120 V_{AC} / 60 Hz.

Remark: The laptop PC shown in Annex A (153143_j.jpg) was removed after adjusting the operation mode and before starting the measurement.

The curves in the diagram only represent for each frequency point the maximum measured value of all preliminary measurements which were made for each power supply line. The top measured curve represents the peak measurement and the bottom measured curve the average measurement. The quasi-peak measured points are marked by **◆** and the average measured points by **+**.

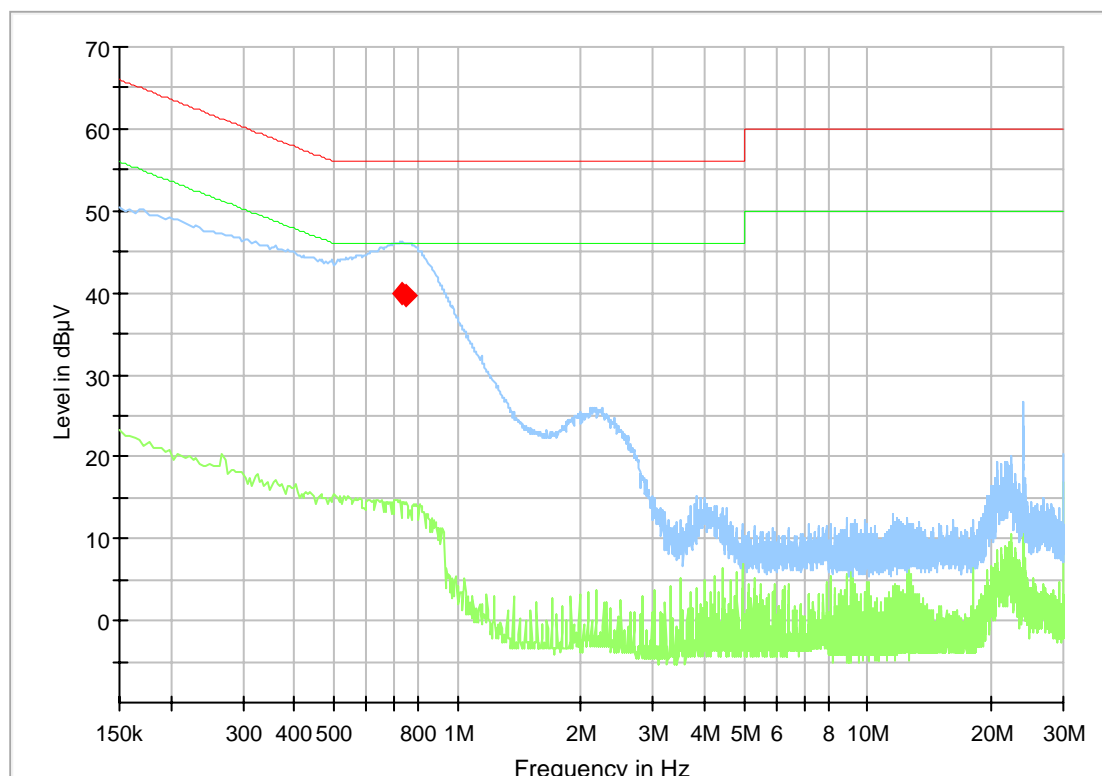

— Preview Result 2-AVG
 — Preview Result 1-PK+
 — FCC 15.207 V QP
— FCC 15.207 V AV
 ◆ Final_Result QPK
 + Final_Result AVG

Data record name: 153143con

Remark: The limits of FCC 15.207 are identical to [3]

Frequency (MHz)	QuasiPeak (dB μ V)	Average (dB μ V)	Limit (dB μ V)	Margin (dB)	Meas. Time (ms)	Bandwidth (kHz)	Line	PE	Transducer (dB)
0.734100	39.80	---	56.00	16.20	5000.0	9.000	L1	GND	9.9
0.753000	39.73	---	56.00	16.27	5000.0	9.000	L1	GND	9.9
Measurement uncertainty			+6.7 dB / -6.0 dB						

Test: Passed

Test equipment used (see chapter 6):

1 - 4, 6, 84

6 Test equipment and ancillaries used for tests

No.	Test equipment	Type	Manufacturer	Serial No.	PM. No.	Cal. Date	Cal. due
1	Shielded chamber M4	-	Siemens	B83117-S1-X158-	480088	Weekly verification (system cal.)	
2	EMI Receiver	ESIB 26	Rohde & Schwarz	1088.7490	481182	03/21/2014	03/2016
3	LISN	NSLK8128	Schwarzbeck	8128161	480138	02/27/2015	02/2016
4	Transient Filter Limiter	CFL 9206A	Teseq GmbH	38268	481982	Weekly verification (system cal.)	
6	EMI Software	EMC 32	Rohde & Schwarz	100061	481022	-	-
14	Open area test site	-	Phoenix Test-Lab	-	480085	Weekly verification (system cal.)	
15	Measuring receiver	ESIB7	Rohde & Schwarz	100304	480521	03/06/2015	03/2017
16	Controller	HD100	Deisel	100/670	480139	-	-
17	Turntable	DS420HE	Deisel	420/620/80	480087	-	-
18	Antenna support	AS615P	Deisel	615/310	480086	-	-
19	Antenna	CBL6111 D	Chase	25761	480894	09/18/2014	09/2017
20	EMI Software	ES-K1	Rohde & Schwarz	-	480111	-	-
29	Fully anechoic chamber M20	-	Albatross Projects	B83107-E2439-T232	480303	Weekly verification (system cal.)	
30	Spectrum analyser	FSU	Rohde & Schwarz	200125	480956	03/09/2015	03/2016
31	Measuring receiver	ESI 40	Rohde & Schwarz	100064	480355	03/02/2015	03/2016
32	Controller	MCU	Maturo	MCU/043/971107	480832	-	-
33	Turntable	DS420HE	Deisel	420/620/80	480315	-	-
34	Antenna support	AS615P	Deisel	615/310	480187	-	-
35	Antenna	CBL6112 B	Chase	2688	480328	04/14/2014	04/2017
36	Antenna	HL50	Rohde & Schwarz	100438	481170	08/27/2014	08/2017
43	RF-cable No. 36	Sucoflex 106B	Suhner	0587/6B	480865	Weekly verification (system cal.)	
44	RF-cable No. 3	Sucoflex 106B	Suhner	0563/6B	480670	Weekly verification (system cal.)	
45	RF-cable No. 40	Sucoflex 106B	Suhner	0708/6B	481330	Weekly verification (system cal.)	
49	Preamplifier	JS3-00101200-23-5A	Miteq	681851	480337	Six month verification (system cal.)	
54	Power supply	TOE 8752	Toellner	31566	480010	-	-
55	Loop antenna	HFH2-Z2	Rohde & Schwarz	100417	481912	09/22/2014	09/2015
73	High Pass Filter	WHJS1000C 11/60EF	Wainwright Instruments GmbH	1	480413	Weekly verification (system cal.)	
75	High Pass Filter	WHKX4.0/18 G-8SS	Wainwright Instruments GmbH	1	480587	Weekly verification (system cal.)	
83	Tuneable Notch Filter	WRCA800/90 0-0.2/40-6EEK	Wainwright Instruments GmbH	15	480414	Weekly verification (system cal.)	
84	Multimeter	971A	Hewlett Packard	JP39009365	480722	03/13/2014	03/2016

