

Test Report

Report Number:

F212088E1

Equipment under Test (EUT):

TN-M18-H1147

Applicant:

Werner Turck GmbH & Co. KG

Manufacturer:

Werner Turck GmbH & Co. KG



Deutsche
Akkreditierungsstelle
D-PL-17186-01-01
D-PL-17186-01-02
D-PL-17186-01-03

References

- [1] **ANSI C63.10: 2013** American National Standard of Procedures for Compliance Testing of Unlicensed Wireless Devices
- [2] **FCC CFR 47 Part 15** Radio Frequency Devices
- [3] **RSS-210 Issue 10 (December 2019)**
Licence-exempt Radio Apparatus (All Frequency Bands): Category I Equipment
- [4] **RSS-Gen Issue 5 (February 2021) Amendment 2**
General Requirements for Compliance of Radio Apparatus

Test Result

“Passed” indicates that the equipment under test conforms with the relevant limits of the testing standard without taking any measurement uncertainty into account as stated in clause 1.3 of ANSI C63.10 (2013). However, the measurement uncertainty is calculated and shown in this test report. The requirements of the tests performed as shown in the overview (clause 4) were fulfilled by the equipment under test. The complete test results are presented in the following.

Tested and
written by:

Signature

Reviewed and
approved by:

Signature

This test report is only valid in its original form.

Any reproduction of its contents in extracts without written permission of the accredited test laboratory PHOENIX TESTLAB GmbH is prohibited.

The test results herein refer only to the tested sample. PHOENIX TESTLAB GmbH is not responsible for any generalisations or conclusions drawn from these test results concerning further samples. Any modification of the tested samples is prohibited and leads to the invalidity of this test report. Each page necessarily contains the PHOENIX TESTLAB Logo and the TEST REPORT NUMBER.

Contents:	Page
1 Identification	4
1.1 Applicant.....	4
1.2 Manufacturer	4
1.3 Test Laboratory	4
1.4 EUT (Equipment under Test)	5
1.5 Technical Data of Equipment	5
1.6 Dates	6
2 Operational States	6
3 Additional Information	7
4 Overview.....	7
5 Results.....	8
5.1 Conducted emissions on power supply lines	8
5.1.1 Test method.....	8
5.1.2 Test results conducted emissions on power supply lines	9
5.2 Radiated emissions	10
5.2.1 Test method.....	10
5.2.2 Test results preliminary measurement 9 kHz to 1 GHz.....	14
5.2.3 Test results final measurement 150 kHz to 30 MHz.....	16
5.2.4 Test results final measurement 30 MHz to 1 GHz.....	17
5.3 99 % bandwidth.....	18
5.3.1 Test method.....	18
5.3.2 Test results 99 % bandwidth	19
6 Test Equipment used for Tests	20
7 Test site Validation	21
8 Report History.....	21
9 List of Annexes	21

1 Identification

1.1 Applicant

Name:	Werner Turck GmbH & Co. KG
Address:	Goethestraße 7 58533 Halver
Country:	Germany
Name for contact purposes:	Mr. Markus TEUBNER
Phone:	+49 23 53 709 – 61 24
eMail address:	markus.teubner@turck.com
Applicant represented during the test by the following person:	---

1.2 Manufacturer

Name:	Werner Turck GmbH & Co. KG
Address:	Goethestraße 7 58533 Halver
Country:	Germany
Name for contact purposes:	Mr. Markus TEUBNER
Phone:	+49 23 53 709 – 61 24
eMail address:	markus.teubner@turck.com
Manufacturer represented during the test by the following person:	---

1.3 Test Laboratory

The tests were carried out by: **PHOENIX TESTLAB GmbH**
Königswinkel 10
32825 Blomberg
Germany

Accredited by Deutsche Akkreditierungsstelle GmbH (DAkkS) in compliance with DIN EN ISO/IEC 17025 under Reg. No. D-PL-17186-01-06 and D-PL-17186-01-05, FCC Test Firm Designation Number DE0004, FCC Test Firm Registration Number 469623, CAB Identifier DE0003 and ISED# 3469A.

1.4 EUT (Equipment under Test)

Test object: *	RFID read/write device
Model name / PMN: *	TN-M18-H1147
Serial number: *	None (engineering sample)
FCC ID: *	YQ7-TNM18W
IC certification number: *	8821A-TNM18W
HVIN: *	1
FVIN: *	VN1.96
Highest internal frequency: *	13.56 MHz

Note: PHOENIX TESTLAB GmbH does not take samples. The samples used for tests are provided exclusively by the applicant.

1.5 Technical Data of Equipment

Operating frequency: *	13.56 MHz		
Power supply: *	Externally 24 V _{DC}		
Rated output power: *	<250 mW		
Supply voltage: *	U _{nom} = 24 V _{DC}	U _{min} = 10 V _{DC}	U _{max} = 30 V _{DC}
Type of modulation: *	ASK		
Antenna connector: *	None		
Number of channels: *	1		
Antenna type: *	Integrated PCB coil antenna with 95 mm ²		
Data rate: *	26.48 kbaud		
Temperature range: *	-25 °C to +70 °C		

*: Declared by the applicant

Ports / Connectors				
Identification	Connector		Length during test	Shielding (Yes / No)
	EUT	Ancillary		
System line (DC and Data)	Four pole M12 connector	Four pole M12 connector	2.5 m	Yes
-	-	-	-	-

Ancillary Equipment	
TAG * ¹	Type TURCK TW-R7.5-B128
Gateway * ¹	BL67 (consisting of PG-DP, 2RFID-S and 8XSG-PD)
External power supply * ²	HC24-2.4 AG from bell power solutions and protection, used for AC power line conducted tests only

*¹: Provided by the applicant

*²: Provided by the laboratory

1.6 Dates

Date of receipt of test sample:	02.07.2021
Start of test:	03.09.2021
End of test:	27.10.2021

2 Operational States

Description of function of the EUT:

The EUT is a RFID Reader/Writer. All tests were carried out with an unmodified test sample.

The following states were defined as the operating conditions:

To set the EUT in operation, it was connected to a TURCK gateway BL67, which was placed outside the measurement environment via a filter type Epcos B84312-C30-H3 of the anechoic chamber. During all tests the EUT was supplied with a 24.0 V_{DC} via the gateway, which was connected to an external power supply.

All tests were carried out with an unmodified test sample, which operates in normal operation mode. If not otherwise stated a TAG type TURCK TW-R7.5-B128 was presented in the front of the EUT.

Because no dedicated position of operating is defined by the applicant, all radiated measurements were carried out with the EUT in two orthogonal positions. For details of the different positions, refer annex A of this test report.

The system was setup as follows:

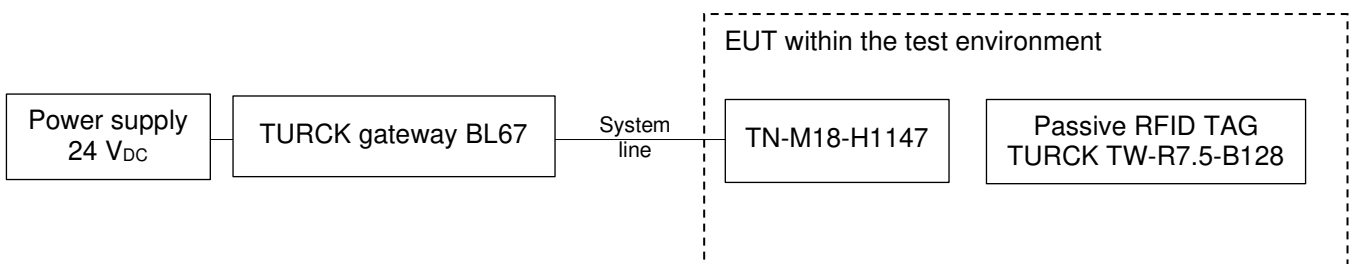

3 Additional Information

The EUT was not labeled.

4 Overview

Application	Frequency range [MHz]	FCC 47 CFR Part 15 section [2]	RSS-Gen, Issue 5 [4] and RSS-210, Issue 10 [3]	Status
Conducted emissions on supply line	0.15 – 30	15.207 (a)	8.8 [4]	Passed
Radiated emissions	0.009 – 1000 **	15.205 (a) 15.209 (a)	8.9 and 8.10 [4] 7.1 and 7.3 [3]	Passed
99 % bandwidth	13.56	-	6.7 [4]	Performed
Antenna requirement	-	15.203 [2]	6.8 [4]	Passed *

*: Integrated antenna only, requirement fulfilled.

** : As declared by the applicant the highest radio clock frequency is 13.56 MHz. Therefore, the radiated emission measurement must be carried out up to 1 GHz.

5 Results

5.1 Conducted emissions on power supply lines

5.1.1 Test method

The test is carried out in a shielded chamber. Table-top devices are set up on a non-conducting support with a size of 1 m by 1.5 m and a height of 80 cm above the ground plane. Floor-standing devices are placed directly on the ground plane. In case of DC powered equipment, which is not exclusively powered by a battery, it is connected to the LISN via a suitable AC/DC adaptor. The setup of the equipment under test is in accordance to [1].

The frequency range 150 kHz to 30 MHz is measured with an EMI receiver set to MAX hold mode with Peak and Average detectors and a resolution bandwidth of 9 kHz. A scan is carried out on the phase and neutral line of the AC mains network. If emissions less than 10 dB below the appropriate limit are detected, these emissions are measured with an Average and Quasi-Peak detector on all lines.

Frequency range	Resolution bandwidth
150 kHz to 30 MHz	9 kHz

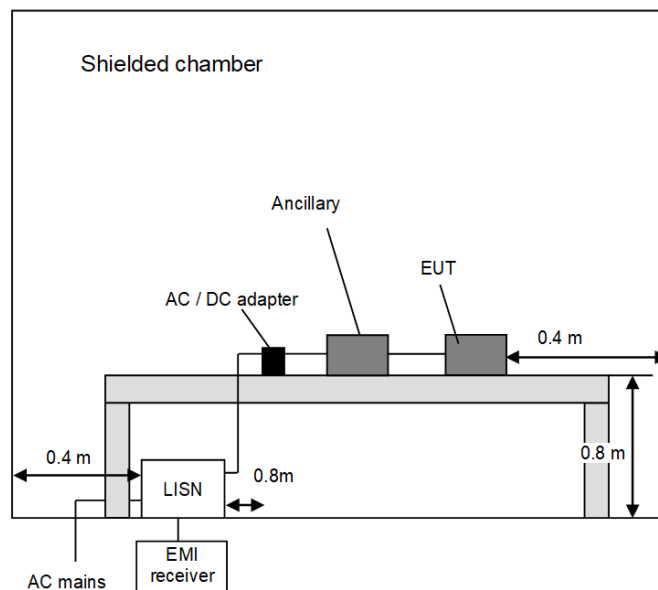

5.1.2 Test results conducted emissions on power supply lines

Ambient temperature:	22 °C
Relative humidity:	49 %

Date:	19.10.2021
Tested by:	Yassine KHALEK

The curves in the diagrams below only represent for each frequency point the maximum measured value of all preliminary measurements which were made for each power supply line. The top measured curve represents the peak measurement and the bottom measured curve the average measurement. The quasi-peak measured points are marked by ◆ and the average measured points by ◆.

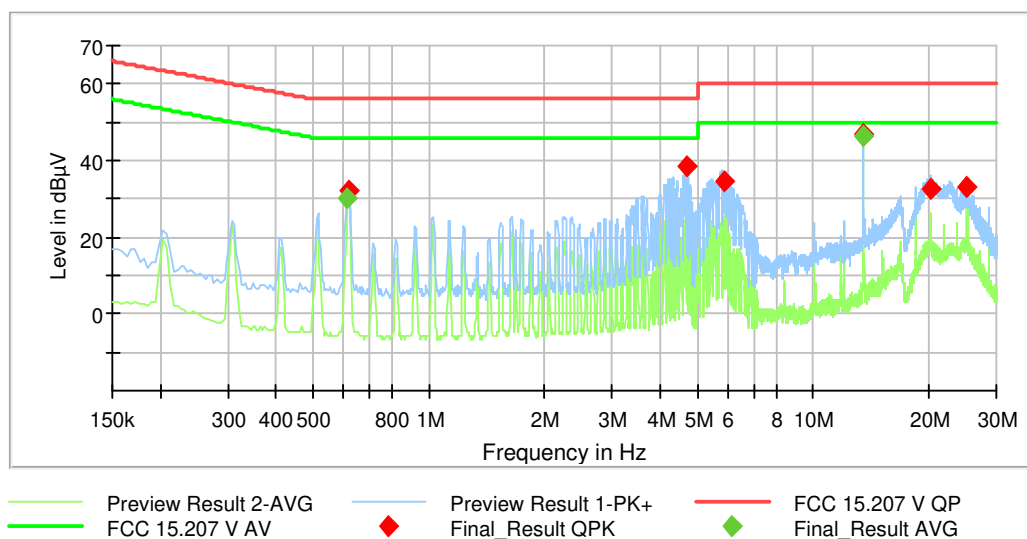

Frequency [MHz]	QuasiPeak [dBµV]	Average [dBµV]	Limit [dBµV]	Margin [dB]	Meas. Time [ms]	Bandwidth [kHz]	Line	PE	Corr. [dB]
0.614400	---	30.4	46.0	15.6	5000	9.0	N	FLO	9.9
0.616200	32.0	---	56.0	24.0	5000	9.0	N	FLO	9.9
4.693200	38.4	---	56.0	17.6	5000	9.0	N	GND	10.3
5.860500	34.4	---	60.0	25.6	5000	9.0	N	FLO	10.4
13.560000	46.8	---	60.0	13.2	5000	9.0	N	GND	10.8
13.560000	---	46.5	50.0	3.5	5000	9.0	N	GND	10.8
20.231700	32.5	---	60.0	27.5	5000	9.0	L1	GND	10.9
25.003500	33.0	---	60.0	27.0	5000	9.0	L1	GND	11.1

Measurement uncertainty ±2.76 dB

Remark: The limits of FCC part 15.209 [2] are identical to the general limits of the RSS-Gen [4]

Test result: Passed

Test equipment (please refer to chapter 6 for details)
1 – 7

5.2 Radiated emissions

5.2.1 Test method

Preliminary measurement 9 kHz to 30 MHz

In the first stage a preliminary measurement is performed in an anechoic chamber with a measuring distance of 3 meters. Table-top devices are set up on a non-conducting support with a size of 1 m by 1.5 m and a height of 80 cm. Floor-standing devices are placed directly on the turntable / ground plane. The setup of the equipment under test is in accordance to [1].

The frequency range 9 kHz to 30 MHz is monitored with an EMI receiver while the system and its cables are manipulated to find out the configuration with the maximum emission levels if applicable. The EMI receiver is set to MAX hold mode. The EUT and the measuring antenna are rotated around their vertical axis to find the maximum emission levels.

The resolution bandwidth of the EMI receiver is set to the following values:

Frequency range	Resolution bandwidth
9 kHz to 150 kHz	200 Hz
150 kHz to 30 MHz	9 kHz

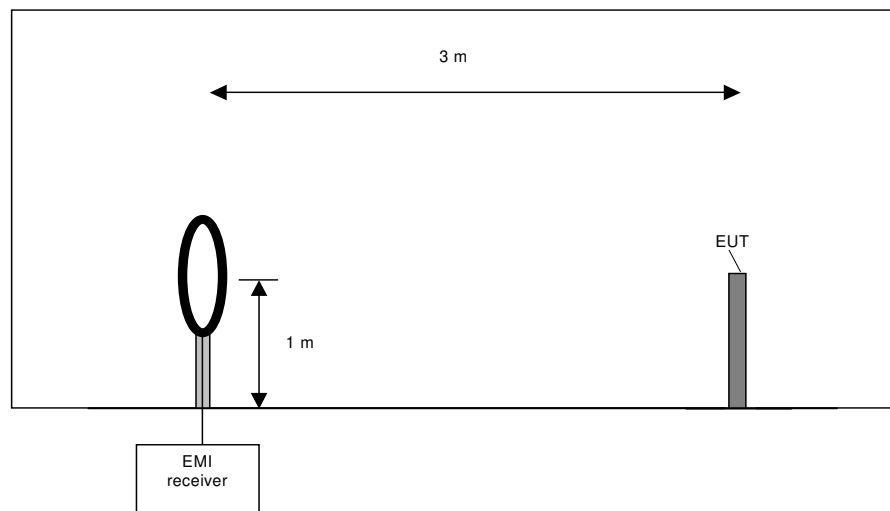

Procedure preliminary measurement:

Pre-scans are performed in the frequency range 9 kHz to 150 kHz and 150 kHz to 30 MHz.

The following procedure is used:

- 1) Monitor the frequency range with the measuring antenna facing the EUT and an EUT / turntable azimuth of 0 °.
- 2) Manipulate the system cables to produce the maximum levels of emissions.
- 3) Rotate the EUT by 360 ° to maximize the detected signals.
- 4) Measure the frequencies of the highest detected emissions with a lower span and resolution bandwidth to increase the accuracy and note the frequency values.
- 5) If the EUT is portable or ceiling mounted, repeat steps 1 to 4 with other orientations (x, y, z) of the EUT.
- 6) Rotate the measuring antenna and repeat steps 1 to 5.

Final measurement 9 kHz to 30 MHz

In the second stage a final measurement is performed on an open area test site with no conducting ground plane in a measuring distances of 3 m, 10 m or 30 m. In the case where larger measuring distances are required the results are extrapolated based on the values measured on the closer distances according to section 15.31 (f) (2) [2]. The final measurement is performed with an EMI receiver set to Quasi-Peak detector, except for the frequency bands 9 kHz to 90 kHz and 110 kHz to 490 kHz where an Average detector is used according section 15.209 (d) [2].

At the frequencies, which were detected during the preliminary measurements, the final measurement is performed while rotating the EUT and the measuring antenna in the range of 0 ° to 360 ° around their vertical axis until the maximum level value is found.

The resolution bandwidth of the EMI receiver is set to the following values:

Frequency range	Resolution bandwidth
9 kHz to 150 kHz	200 Hz
150 kHz to 30 MHz	9 kHz

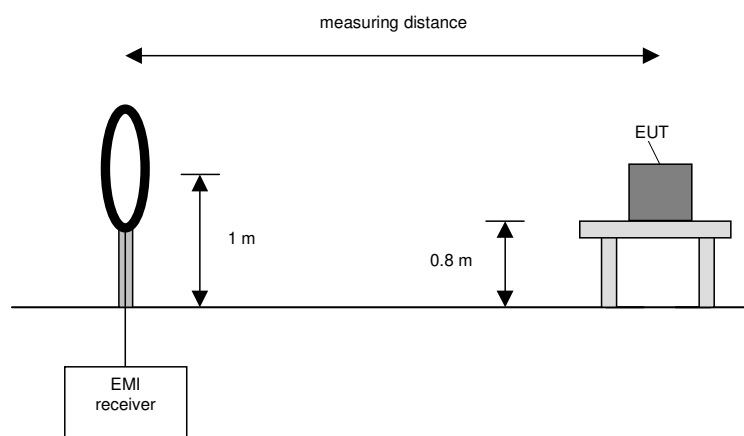

Procedure final measurement:

The following procedure is used:

- 1) Monitor the selected frequencies from the preliminary measurement with the measuring antenna facing the EUT and an EUT azimuth of 0 °.
- 2) Rotate the EUT by 360 ° to maximize the detected signals.
- 3) Rotate the measuring antenna and repeat steps 1 to 2 until the maximum value is found and note it.
- 4) If the EUT is portable or ceiling mounted, repeat steps 1 to 3 with other orientations (x, y, z) of the EUT.

Preliminary and final measurement 30 MHz to 1 GHz

The preliminary and final measurements are performed in a semi-anechoic chamber with a metal ground plane in a 3 m distance.

During the tests the EUT is rotated in the range of 0 ° to 360 °, the measuring antenna is set to horizontal and vertical polarization and raised and lowered in the range from 1 m to 4 m to find the maximum level of emissions.

The resolution bandwidth of the EMI Receiver is set to the following values:

Test	Frequency range	Resolution bandwidth
Preliminary measurement	30 MHz to 1 GHz	100 kHz
Frequency peak search	+ / - 1 MHz	10 kHz
Final measurement	30 MHz to 1 GHz	120 kHz

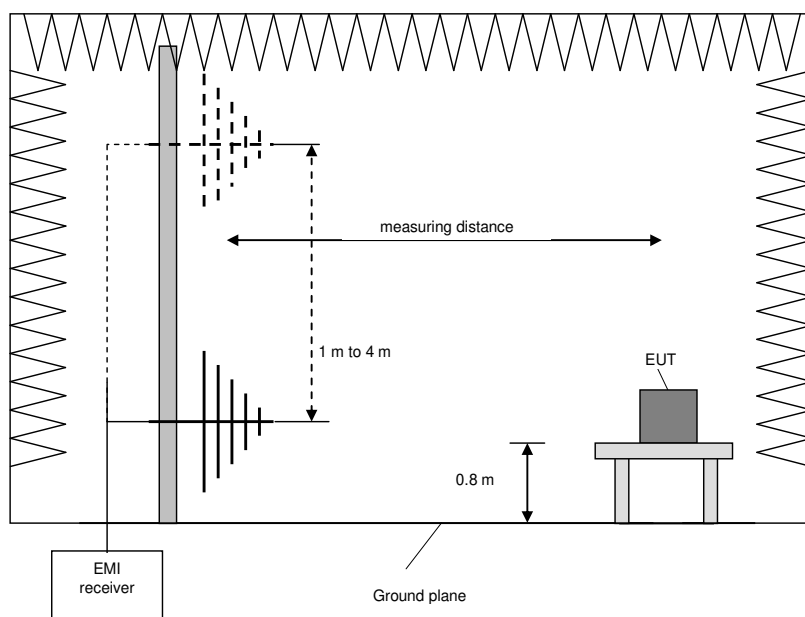

Procedure preliminary measurement:

The following procedure is used:

- 1) Set the measuring antenna to 1 m height.
- 2) Monitor the frequency range at horizontal polarisation of the measuring antenna and an EUT / turntable azimuth of 0 °.
- 3) Rotate the EUT by 360° to maximize the detected signals.
- 4) Repeat steps 2 to 3 with the vertical polarisation of the measuring antenna.
- 5) Increase the height of the measuring antenna for 0.5 m and repeat steps 2 to 4 until the final height of 4 m is reached.
- 6) The highest values for each frequency are saved by the software, including the measuring antenna height and polarization and the turntable azimuth for that value.

Procedure final measurement:

The following procedure is used:

- 1) Select the highest frequency peaks (lowest margin to the limit) for the final measurement.
- 2) The software determines the exact peak frequencies by doing a partial scan with reduced RBW with +/- 10 times the RBW of the pre-scan of the selected peaks.
- 3) If the EUT is portable or ceiling mounted, find the worst-case EUT orientation (x, y, z) for the final test.
- 4) The worst-case measuring antenna height is found via varying the height by +/- 0.5 m from the value obtained in the preliminary measurement while monitoring the emission level.
- 5) The worst-case turntable position is found via varying the turntable azimuth by +/- 30° from the value obtained in the preliminary measurement while monitoring the emission level.
- 6) The final measurement is performed at the worst-case measuring antenna height and the worst-case turntable azimuth.
- 7) Steps 2 to 6 are repeated for each frequency peak selected in step 1.

5.2.2 Test results preliminary measurement 9 kHz to 1 GHz

Ambient temperature:	22 °C / 22 °C
Relative humidity:	40 % / 45 %

Date:	27.10.2021 / 03.09.2021
Tested by:	Yassine KHALEK / Thomas KÜHN

The curves in the diagrams only represent the maximum measured value for each frequency point of all preliminary measurements, which were carried out with various EUT and antenna positions.

Spurious emissions from 9 kHz to 30 MHz:

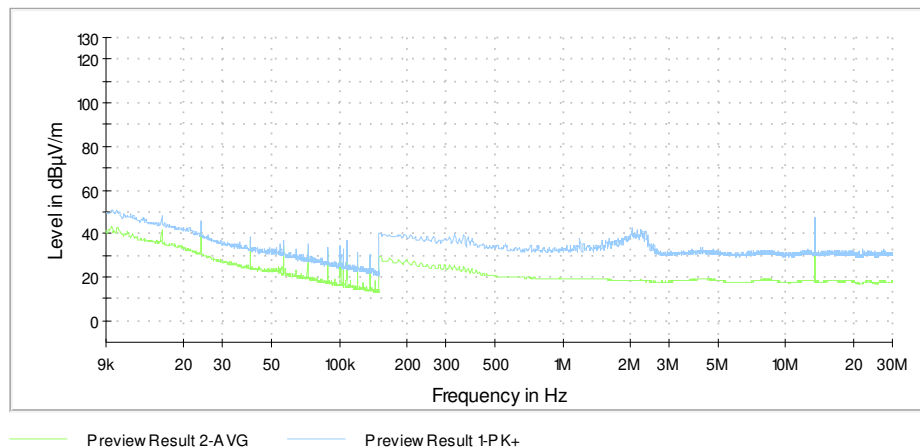

Preview Result 2-AVG Preview Result 1-PK+

Spurious emissions from 30 MHz to 1 GHz:

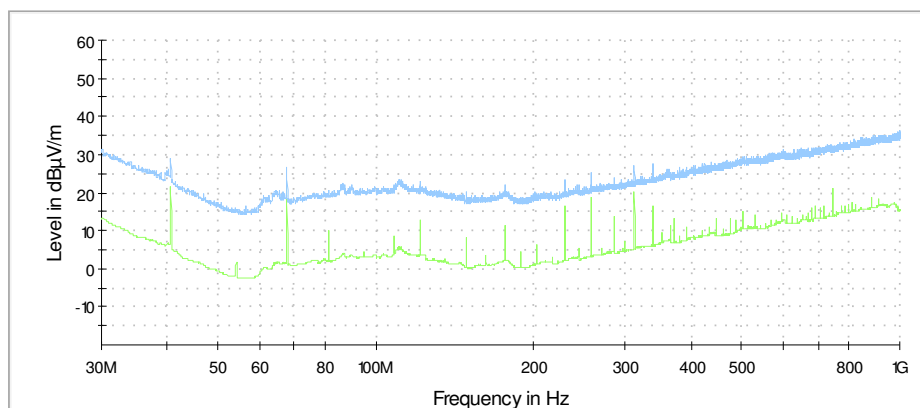

Preview Result 2-AVG Preview Result 1-PK+

The results of the final measurement were presented on the following pages. The measured results (levels) refer to the above-mentioned standard while taking account of the specified requirements for a 3 m measuring distance.

The following emissions were found during the preliminary measurement:

13.560 MHz, 40.670 MHz, 67.800 MHz, 311.880 MHz, 339.000 MHz, 745.590 MHz and 999.540 MHz

On these frequencies a final measurement has to be carried out. The final results are presented in the following.

Test equipment (please refer to chapter 6 for details)
--

6 – 16, 18

5.2.3 Test results final measurement 150 kHz to 30 MHz

Ambient temperature:	15 °C
Relative humidity:	52 %

Date:	26.10.2021
Tested by:	Yassine KHALEK

The results of the standard-compliant re-measurement on the outdoor test site are given in the table below. The limit values as well as the measurement results (levels) refer to the above standard, taking into account the specified requirements for both the prescribed and the measurement distance used.

Result 9 kHz - 30 MHz												
Frequency	Reading @ measuring distance	Result* @ norm. dist.	Result* @ norm. dist.	Limit acc. 15.209	Limit acc. RSS-Gen Table 6	Margin**	Detector	Antenna factor	Measuring Distance	Normative distance	Distance correction factor***	Position
[MHz]	[dBμV]	[dBμV/m]	[dBμA/m]	[dBμV/m]	[dBμA/m]	[dB]		[dB/m]	[m]	[m]	[dB]	
13.560	25.0	4.9	-46.5	29.5	-21.9	24.6	QP	19.9	3	30	40	1
Measurement uncertainty: ±4.36 dB												

* Result @ norm. dist. = Reading @ measuring distance + Antenna factor - Distance correction factor;

Result [dBμA/m] = Result [dBμV/m] - 20*log(377 Ω)

** Margin = Limit [dBμ{V|A}/m] - Result @ norm dist.

*** 40dB/decade according Part §15.31 (f) (2)

Remark: At 10 m measuring distance the signal of the EUT was below the sensitivity of the measuring system.

Test result: Passed

Test equipment (please refer to chapter 6 for details)
6, 7, 17 – 19

5.2.4 Test results final measurement 30 MHz to 1 GHz

Ambient temperature:	22 °C
Relative humidity:	45 %

Date:	03.09.2021
Tested by:	Thomas KÜHN

The measured points and the limit line in the following diagram refer to the standard measurement of the emitted interference in compliance with the above-mentioned standard. The measured points marked with “◆” are the measured results of the standard subsequent measurement in a semi-anechoic chamber.

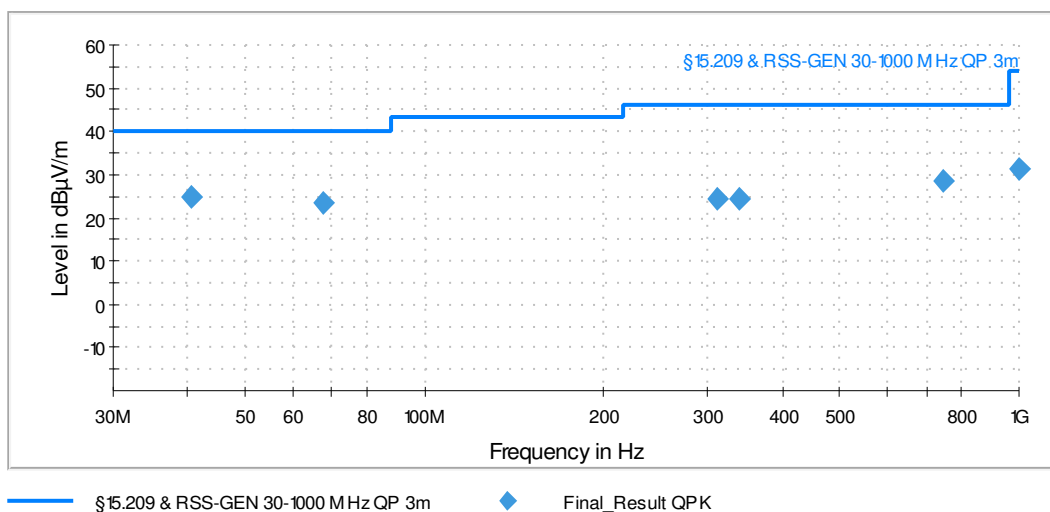

The results of the standard subsequent measurement in a semi-anechoic chamber are indicated in the table below. The limits as well as the measured results (levels) refer to the above-mentioned standard while taking account of the specified requirements for a 3 m measuring distance.

Frequency [MHz]	QuasiPeak [dBµV/m]	Limit [dBµV/m]	Margin [dB]	Meas. Time [ms]	Bandwidth [kHz]	Height [cm]	Pol	Azimuth [deg]	Corr. [dB]	Position
40.670	24.9	40.0	15.1	1000	120.000	100.0	V	113	19.7	1
67.800	23.3	40.0	16.7	1000	120.000	162.0	V	194	14.3	2
311.880	24.4	46.0	21.6	1000	120.000	120.0	H	135	19.4	1
339.000	24.3	46.0	21.7	1000	120.000	100.0	H	239	20.2	1
745.590	28.5	46.0	17.5	1000	120.000	238.0	H	279	28.0	1
999.540	31.2	54.0	23.8	1000	120.000	191.0	H	250	30.9	2
Measurement uncertainty ±5.12 dB										

Test result: Passed

The correction factor was calculated as follows:

$$\text{Corr. [dB]} = \text{cable attenuation [dB]} + 6 \text{ dB attenuator [dB]} + \text{antenna factor [dB]}$$

Therefore, the reading can be calculated as follows:

$$\text{Reading [dBµV/m]} = \text{result QuasiPeak [dBµV/m]} - \text{Corr. [dB]}$$

Test equipment (please refer to chapter 6 for details)
6 - 16

5.3 99 % bandwidth

5.3.1 Test method

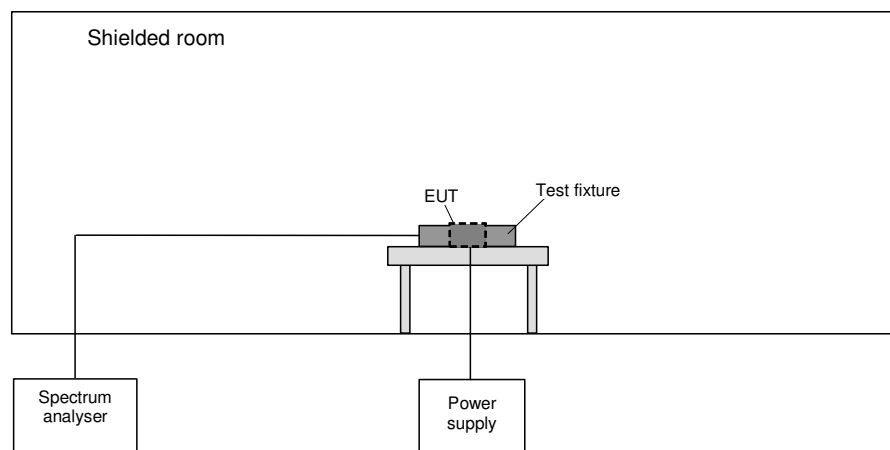

The following procedure is used for the occupied bandwidth measurement according to [1]:

The occupied bandwidth is the frequency bandwidth such that, below its lower and above its upper frequency limits, the mean powers are each equal to 0.5% of the total mean power of the given emission. The following procedure is used for measuring the 99% power bandwidth:

- 1) The instrument center frequency is set to the nominal EUT channel center frequency. The frequency span for the spectrum analyzer shall be between 1.5 times and 5.0 times the OBW.
- 2) The nominal IF filter bandwidth (3 dB RBW) shall be in the range of 1% to 5% of the OBW, and VBW shall be approximately three times the RBW, unless otherwise specified by the applicable requirement.
- 3) Set the reference level of the instrument as required, keeping the signal from exceeding the maximum input mixer level for linear operation. In general, the peak of the spectral envelope shall be more than $[10 \log (\text{OBW}/\text{RBW})]$ below the reference level. Specific guidance is given in 4.1.5.2.
- 4) Step 1) through step 3) might require iteration to adjust within the specified range.

5.3.2 Test results 99 % bandwidth

Ambient temperature:	22 °C
Relative humidity:	45 %

Date:	03.09.2021
Tested by:	Thomas KÜHN

210221_1.png: 99% Bandwidth:

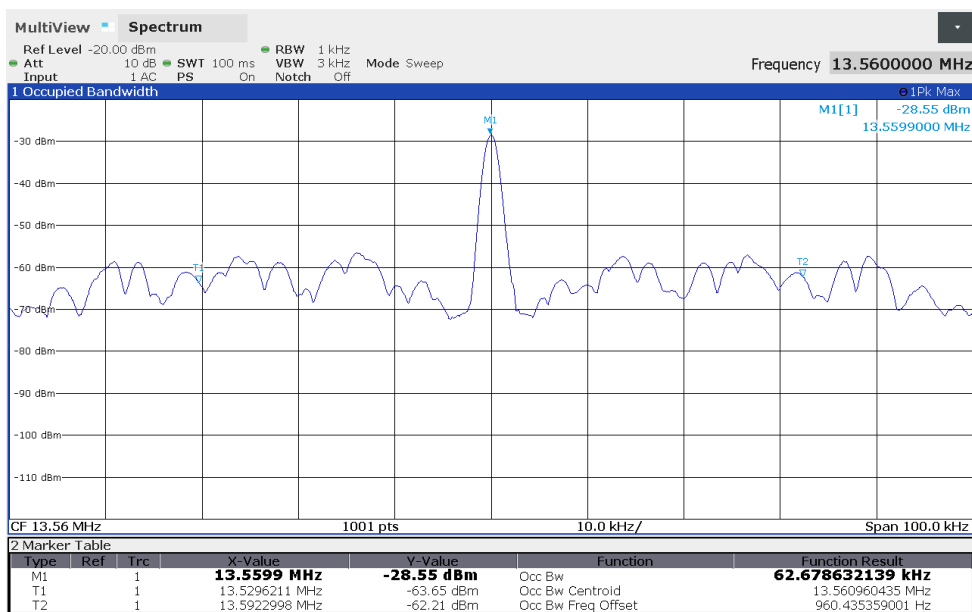

FL	FU	BW (FU - FL)
13.529621 MHz	13.592300 MHz	62.7 kHz
Measurement uncertainty < 1*10 ⁻⁷		

Test equipment (please refer to chapter 6 for details) 6, 7, 16, 20
--

6 Test Equipment used for Tests

No.	Test equipment	Type	Manufacturer	Serial No.	PM No.	Cal Date	Cal Due
1	Shielded chamber M4	B83117-S1-X158	Siemens	190075	480088	Calibration not necessary	
2	EMI Receiver	ESIB 26	Rohde & Schwarz	100292	481182	12.02.2020	02.2022
3	LISN	NSLK8128	Schwarzbeck	8128161	480138	11.02.2020	02.2022
4	Transient Filter Limiter	CFL 9206A	Teseq GmbH	38268	481982	Calibration not necessary	
5	EMI Software	EMC 32	Rohde & Schwarz	100061	481022	Calibration not necessary	
6	Digital multimeter	971A	Hewlett Packard	JP39009358	480721	17.02.2021	02.2022
7	AC source	AC6803A	Keysight	JPVJ002509	482350	Calibration not necessary	
8	Semi Anechoic Chamber M276	SAC5-2	Albatross Projects	C62128-A540-A138-10-0006	483227	Calibration not necessary	
9	Ultralog Antenna	HL562E	Rohde & Schwarz	101079	482978	18.03.2021	03.2024
10	Turntable	TT3.0-3t	Maturo	825/2612/01	483224	Calibration not necessary	
11	Antenna support	BAM 4.5-P-10kg	Maturo	222/2612.01	483225	Calibration not necessary	
12	Controller	NCD	Maturo	474/2612.01	483226	Calibration not necessary	
13	RF Switch Matrix	OSP220	Rohde & Schwarz	-	482976	Calibration not necessary	
14	Cable 416	Sucoflex 116	Huber & Suhner	500651/119	-	Calibration not necessary	
15	Software	EMC32	Rohde & Schwarz	100970	482972	Calibration not necessary	
16	EMI Receiver	ESW44	Rohde & Schwarz	101828	482979	17.10.2019	10.2021
17	Outdoor test site	-	PHOENIX-Testlab	-	480293	Calibration not necessary	
18	Loop antenna	HFH2-Z2	Rohde & Schwarz	100417	480912	25.02.2021	02.2022
19	EMI Receiver / Spectrum Analyser	ESI 40	Rohde & Schwarz	100064/040	480355	25.02.2021	02.2022
20	Loop Antenna Ø = 110 mm	-	Phoenix Test-Lab	-	410084	Calibration not necessary	

7 Test site Validation

Test equipment	PM. No.	Frequency range	Type of validation	According to	Val. Date	Val Due
Semi anechoic chamber M276	483227	30 – 1000 MHz	NSA	ANSI C63.4a-2017	03.03.2021	02.03.2023
Semi anechoic chamber M276	483227	1 -18 GHz	SVSWR	CISPR 16-1-4 + Cor1:2010 + A1:2012 +A2:2017	25.02.2021	24.02.2023
Shielded chamber M4	480088	9 kHz – 30 MHz	GND-Plane	ANSI C63.4-2014	12.05.2020	11.05.2022

8 Report History

Report Number	Date	Comment
F212088E1	08.11.2021	Initial Test Report
-	-	-
-	-	-

9 List of Annexes

Annex A	Test Setup Photos	9 pages
Annex B	External EUT Photos	4 pages
Annex C	Internal EUT Photos	5 pages