

# CIRCUIT DESCRIPTION

## 1、 GSM RF Circuit: Transmitter and Receiver

As the following PIC, the GSM signal is received by GAM ANT, then it through the power amplifier (U801), and the GSM signal is separated to 4 bands according current net types: GSM850/GSM900/DCS1800/PCS1900, then the signal will be filtrated by the sawfilter (Z801 Z802 Z803) according the different bands, final, the signal is demodulated to audio signal by MT6252. when transmitting, the audio signal will modulated to RF signal, then it is enlarged by U801, then eradiate to the air by GSM ANT.

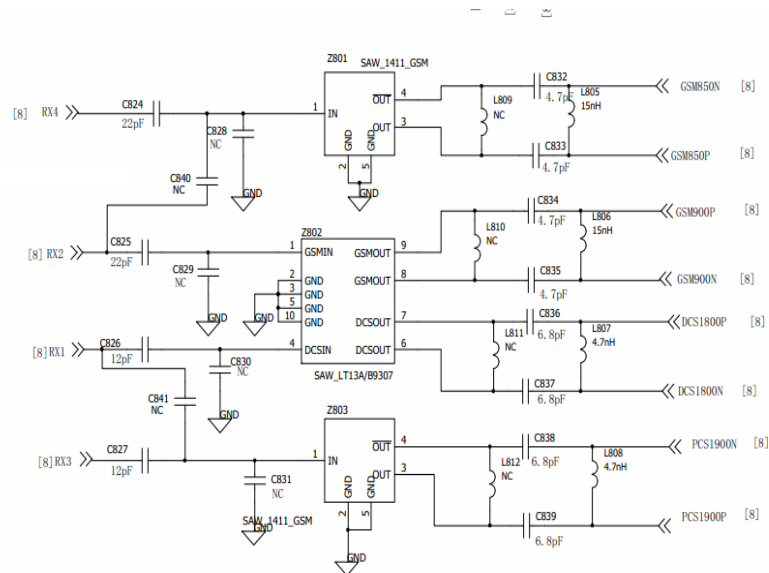

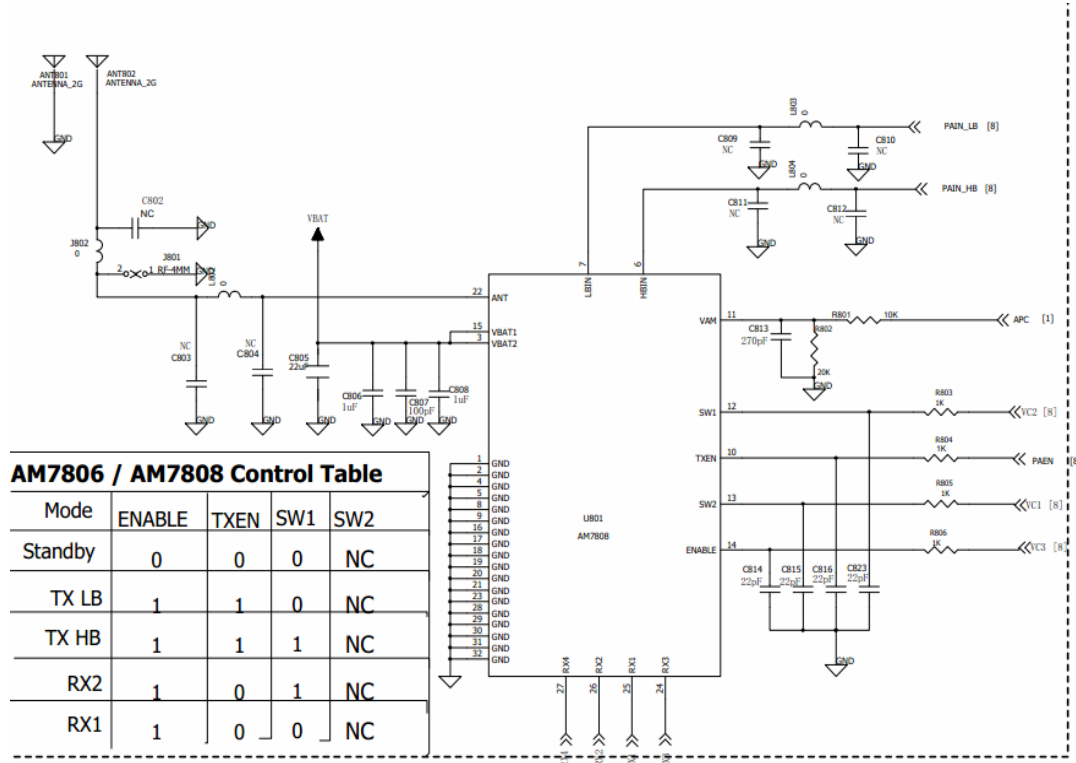
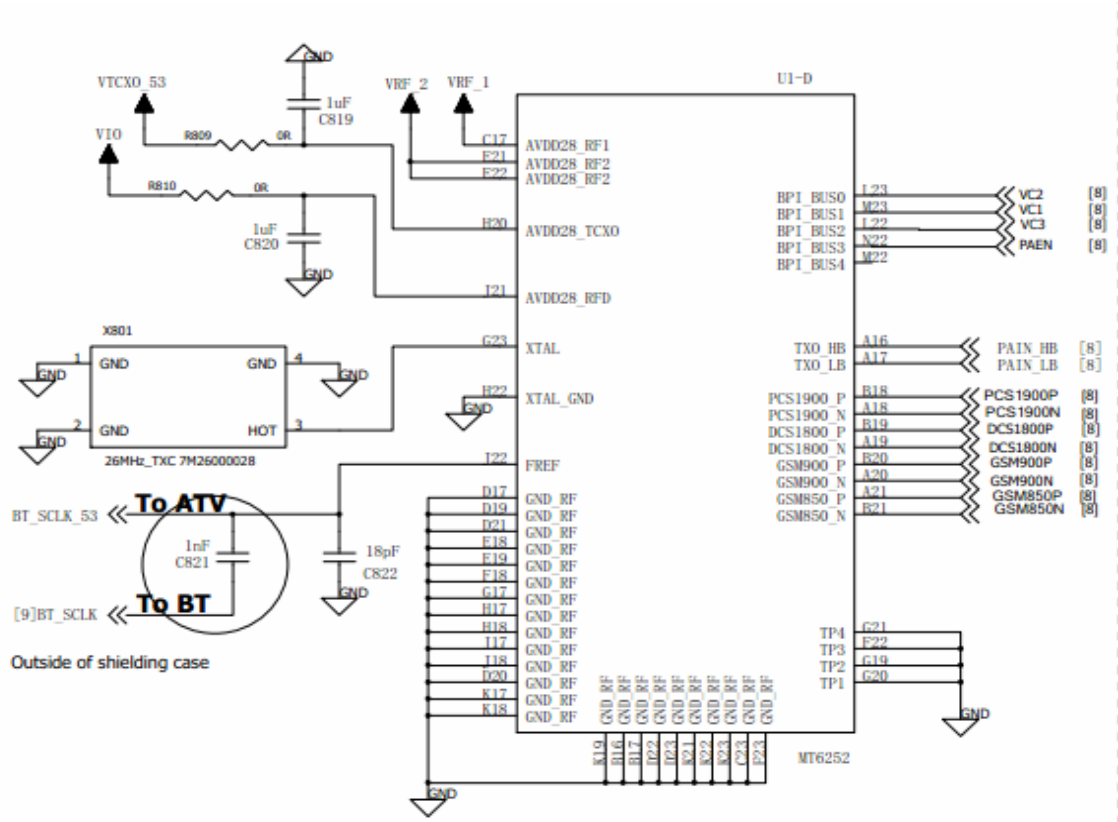

Outside of shielding case

## 2、 GSM ANT Circuit

The GSM ANT is monopole type. It's frequency band is 4 bands: GSM850/GSM900/DCS1800/PCS1900 .J802, C802, make up of the antenna RC matching circuit. When receiver, the antenna receive the RF signal, and then demodulated by MT6252 ,when transmitting, the antenna transmit the RF signal to GSM net.

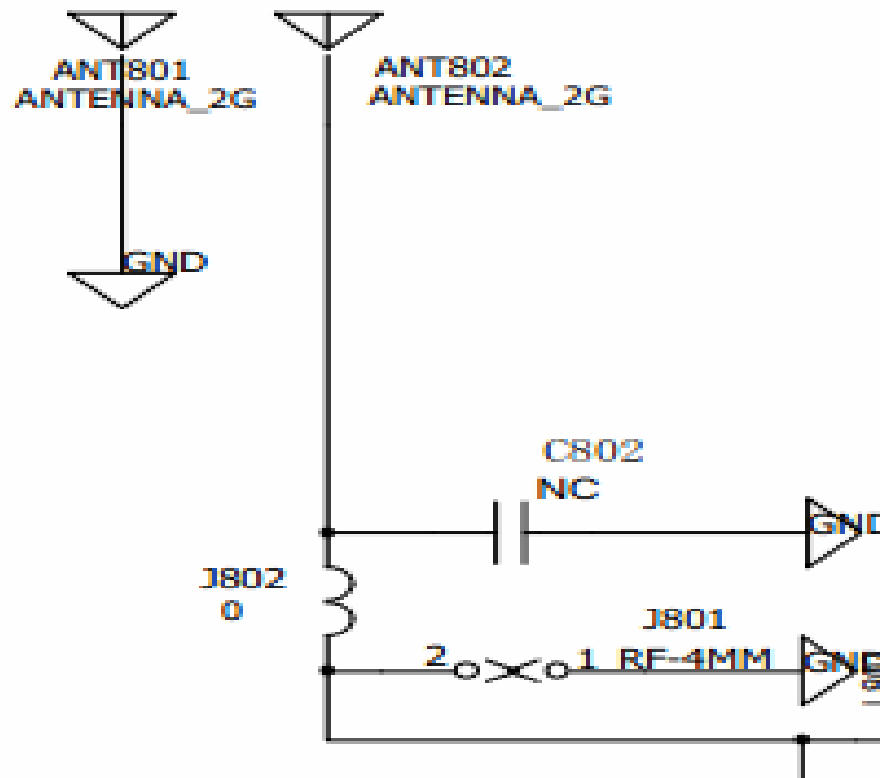

### 3.Power ON/OFF Circuit

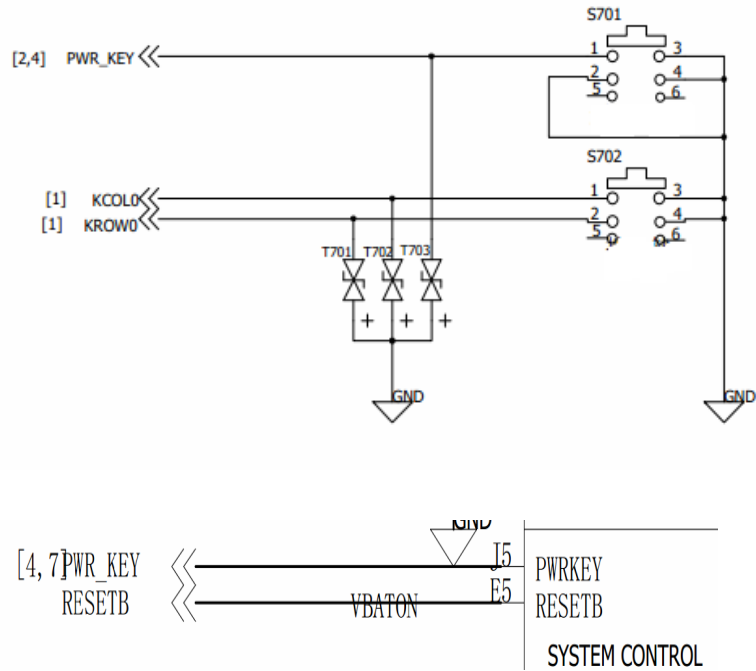

After inserting the battery, VRTC output voltage of 2V, and then the 32.768KHZ crystal start to work. Now press the power on/off switch SW1, then the program start initialing. Press the power on/off switch about 2s at normal status, CPU MT6252 will detect the signal and start the power off program.

## 4、Charger Circuit

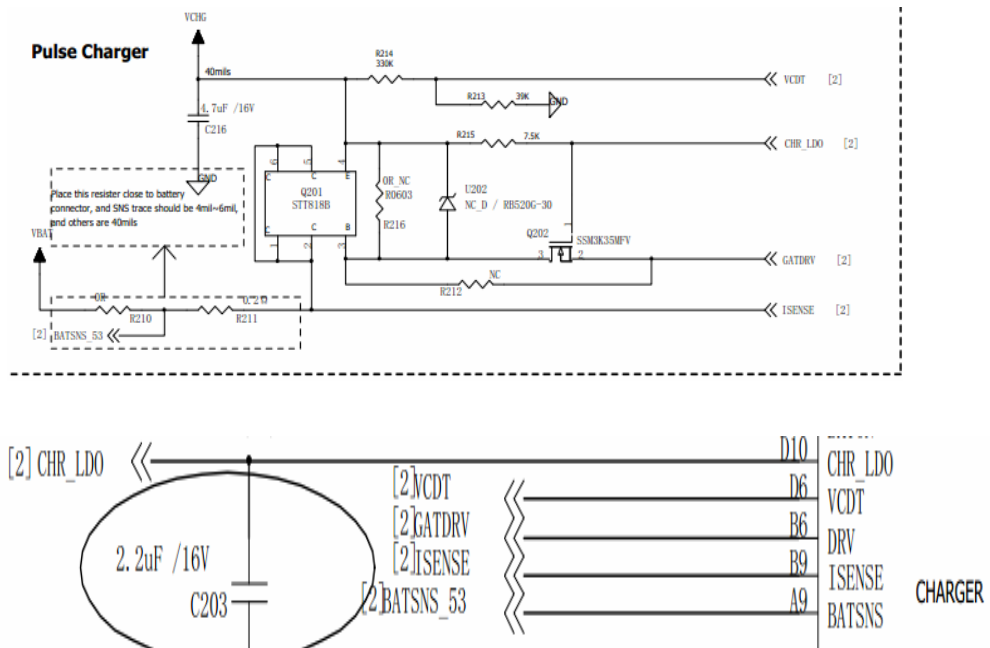

The MT6252 integrate the charger control circuit. When inserting the charging adapter, CHRIN detect high level, and start the charging program. The MT6252 will output the GATEDRV, then drive the MOSFET Q201 to charge the battery, By detecting the current of R214 ,the MT6252 can adjust the voltage of GATEDRV to chang the charging current, still charging finished.

## 5、LCD Circuit

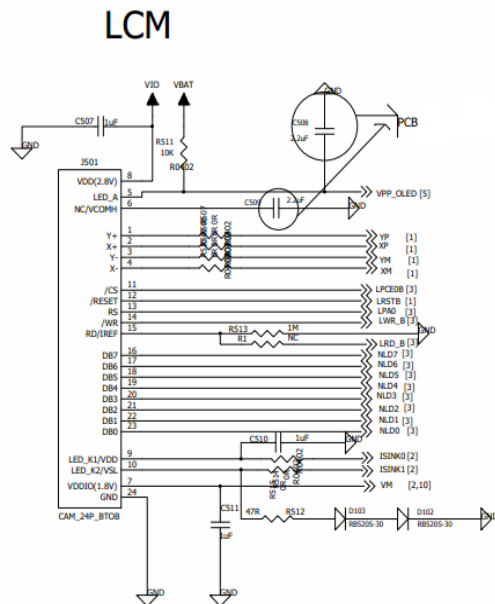

The LCD connects to MT6252 through FPC. The signals are defined as follows:  
VDD: 2.8V,LCD inner driver voltage, provided by MT6252  
LRSTB: Reset signal  
LWRB: LCD writing signal

LRDB: LCD reading signal  
 LPCE0B: LCD chip select signal  
 LPA0: Register select  
 NLD0~NLD7: LCD data signal

## 6、LCD Backlight Circuit

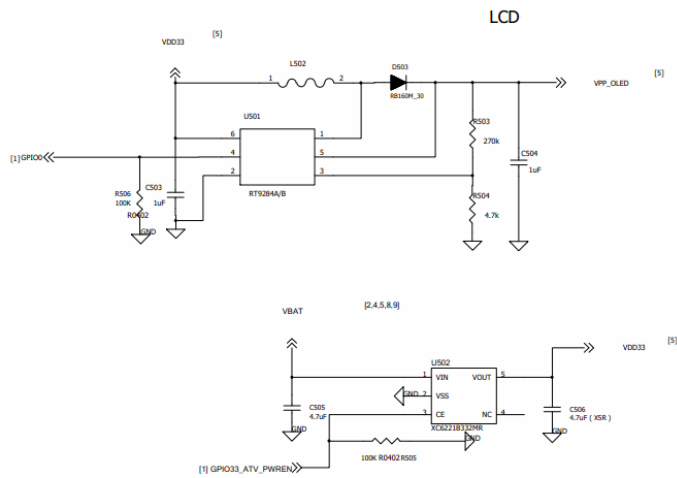

LCD backlight is provided by U501. It will output 15V voltage to the LED.

## 7、Keypad Circuit

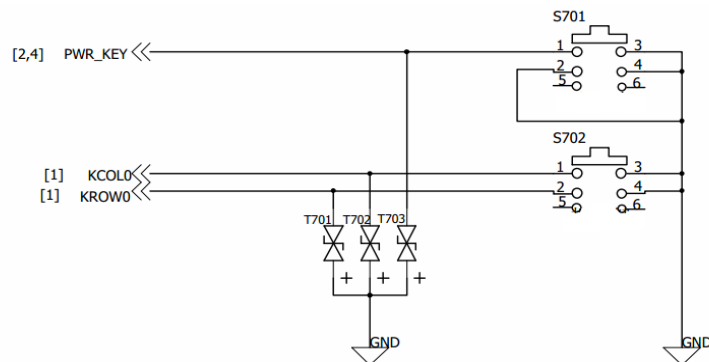

The keypad contains S701 and S702.

## 8、 Keypad Backlight Circuit

NONE

## 9、 Audio Circuit

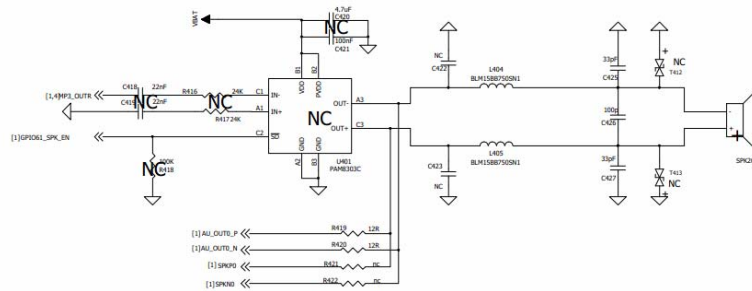

The audio amplifier is PAM8303, class D, controlled by the GPIO61\_PWREN. The speaker should use 8 ohm.

This is mic-phone circuit. MICBIAS provides the bias voltage for microphone.

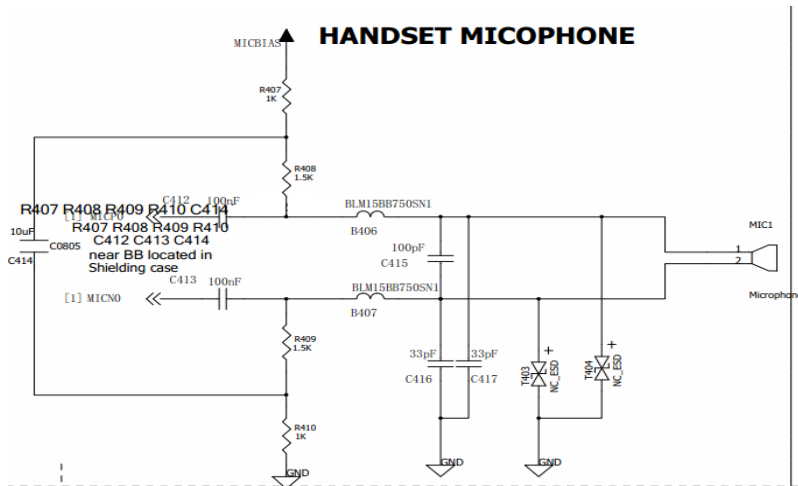

## 10.SIM Card Circuit

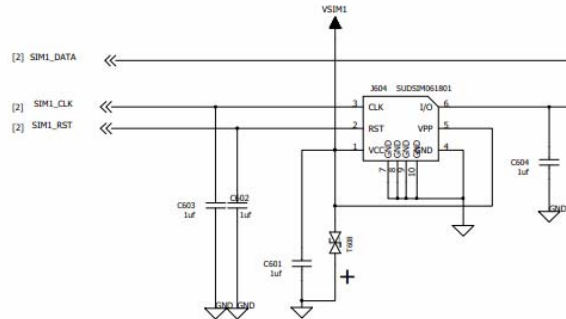

SIM card pin defined as follows:  
VSIM1: SIM card voltage supply,  
SIO1: Data input/output  
SCLK1: Clock signal  
SRST1: Reset signal



# 11、I/O and audio jack Circuit

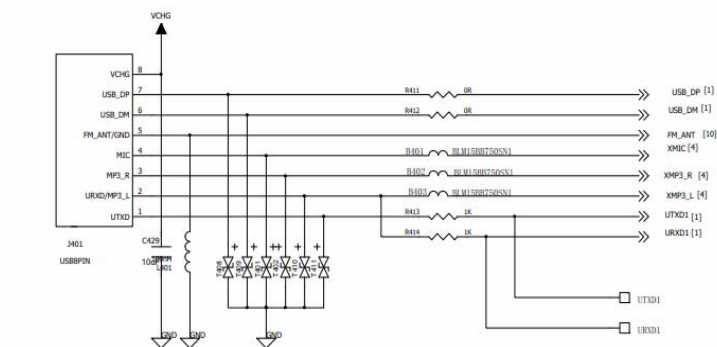

## HEADSET EarPhone

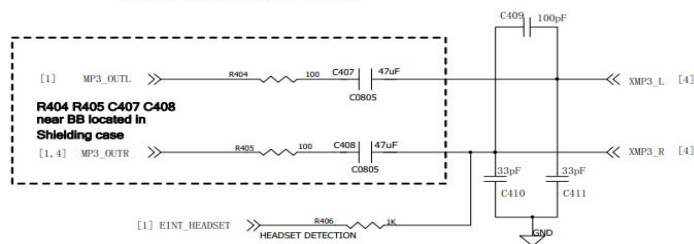

## HEADSET MICOPHONE

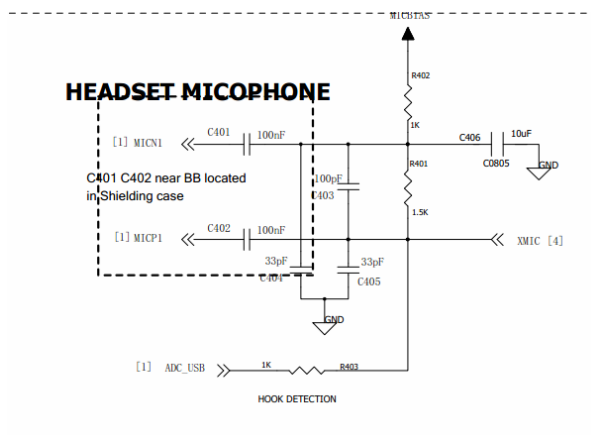

The I/O circuit contains earphone port, UART port, USB port and charge input. and.XMP3\_L is detecting pin for earphone insert. For normal it is high, and become low when earphone insert.



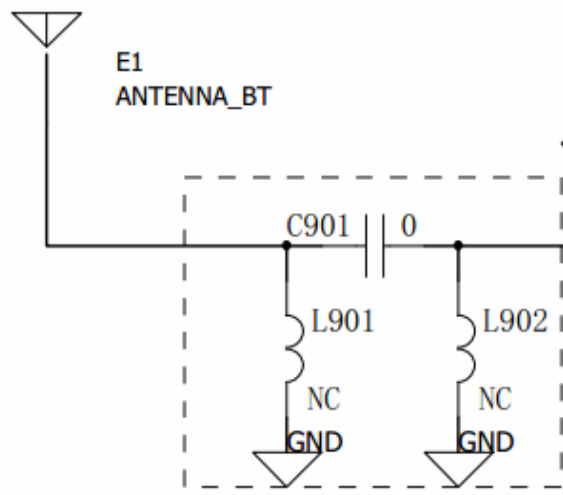

Close to Antenna

## 14、 The GND SYSTEM

All the GND nets are connected by PCB, and the GND is full connected by router,vias and coppers. The GND net of LCD is connector by the LCD connector: J503. When charging, the GND net is connected by I/O connector(J501) to the charger, then to power supply system.The metallic shell is connected to the GND net by metallic shrapnel.

