

1 RX antenna switch SCH (Refer to SCH)

The aerial signal mobile phone received goes from antenna to RF testpoint. RF testpoint, which is a special parts developed for RF test. By connecting RF cable to spectrum analyzer, you can measure RF signal.

Signal output from RF testpoint will be input to the Dual band front-end module U101 (SKY77555). The module has two RX ports for GSM850/EGSM900 and DCS1800/PCS1900 bands of operation. The two RX ports are symmetrical; they can be used either as GSM850/EGSM900 and DCS1800/PCS1900 bands of operation. To control the mode of operation, there are three logic control signals: VSW_EN, PAEN, and BAND_SW.

RF channel CTRL logic	BPI_BUS1	BPI_BUS3	BPI_BUS2
STANDBY	VSW_EN = 0	PAEN = 0	BAND_SW = 0
RX1 (GSM)	1	0	0
RX2 (DCS)	1	0	1
GSM850/900 TX Mode	1	1	0
DCS1800/PCS1900 TX Mode	1	1	1

2 RX SAW Filter SCH

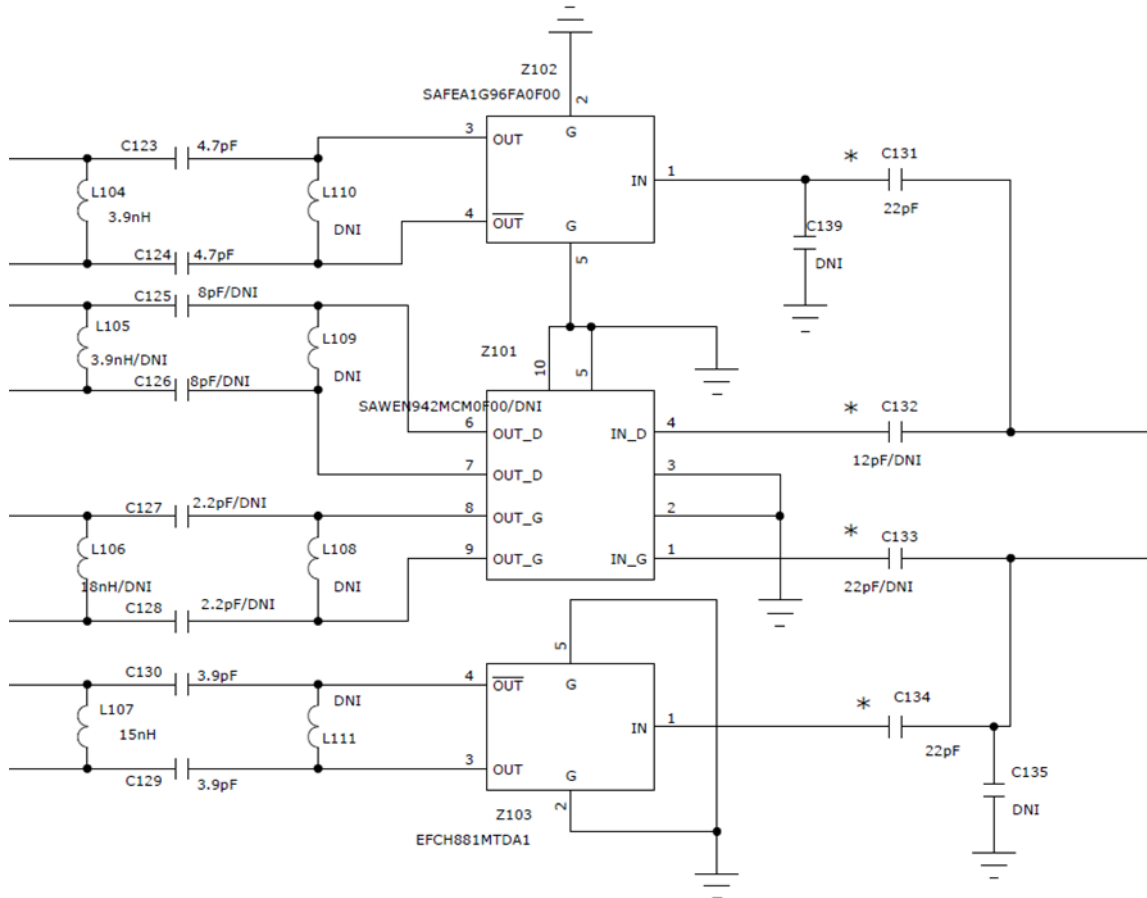

The RX signal output from RF antenna Switch(internal in RF PA), then input SAW filter .changed two difference signals in SAW filter,then input the Baseband CPU U201.

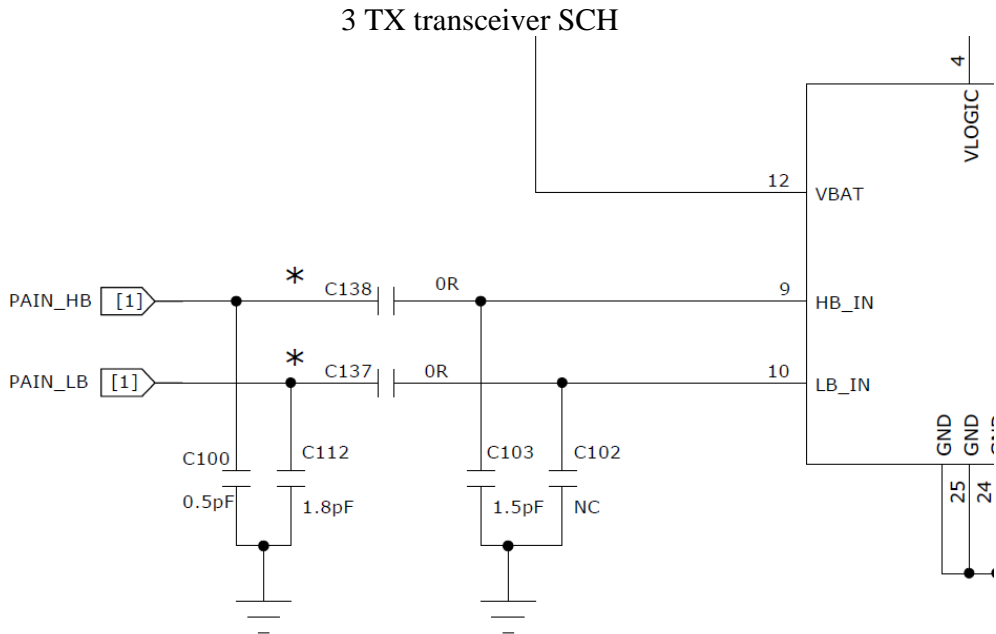

RF PA 9,10 pin connected to the CPU U201 of the A16, A17 pin.

MT6252DA

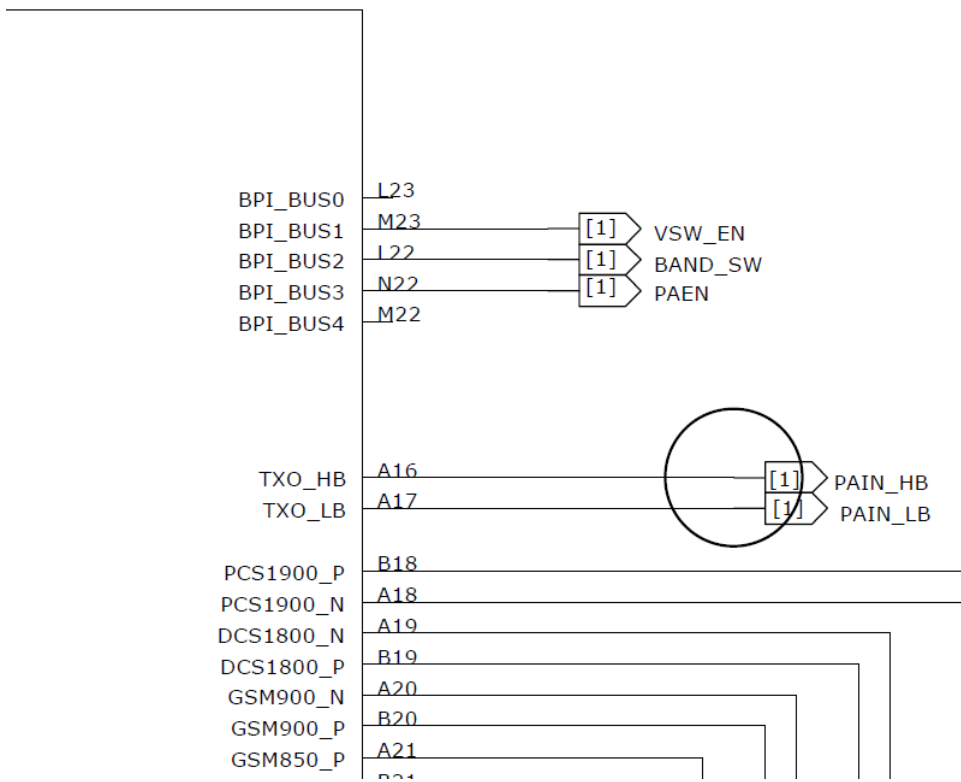

The RF overall schematic as up. It contains the TX path and RX path. The signal received from the air will be demodulated in CPU through RX SAW and Transceiver, Then the original voice signal will driver the receiver. At the same time the signal from microphone will be sent to transceiver through CPU, then be amplified by RF PA, at last sent to air from the antenna switch(internal in RF PA).

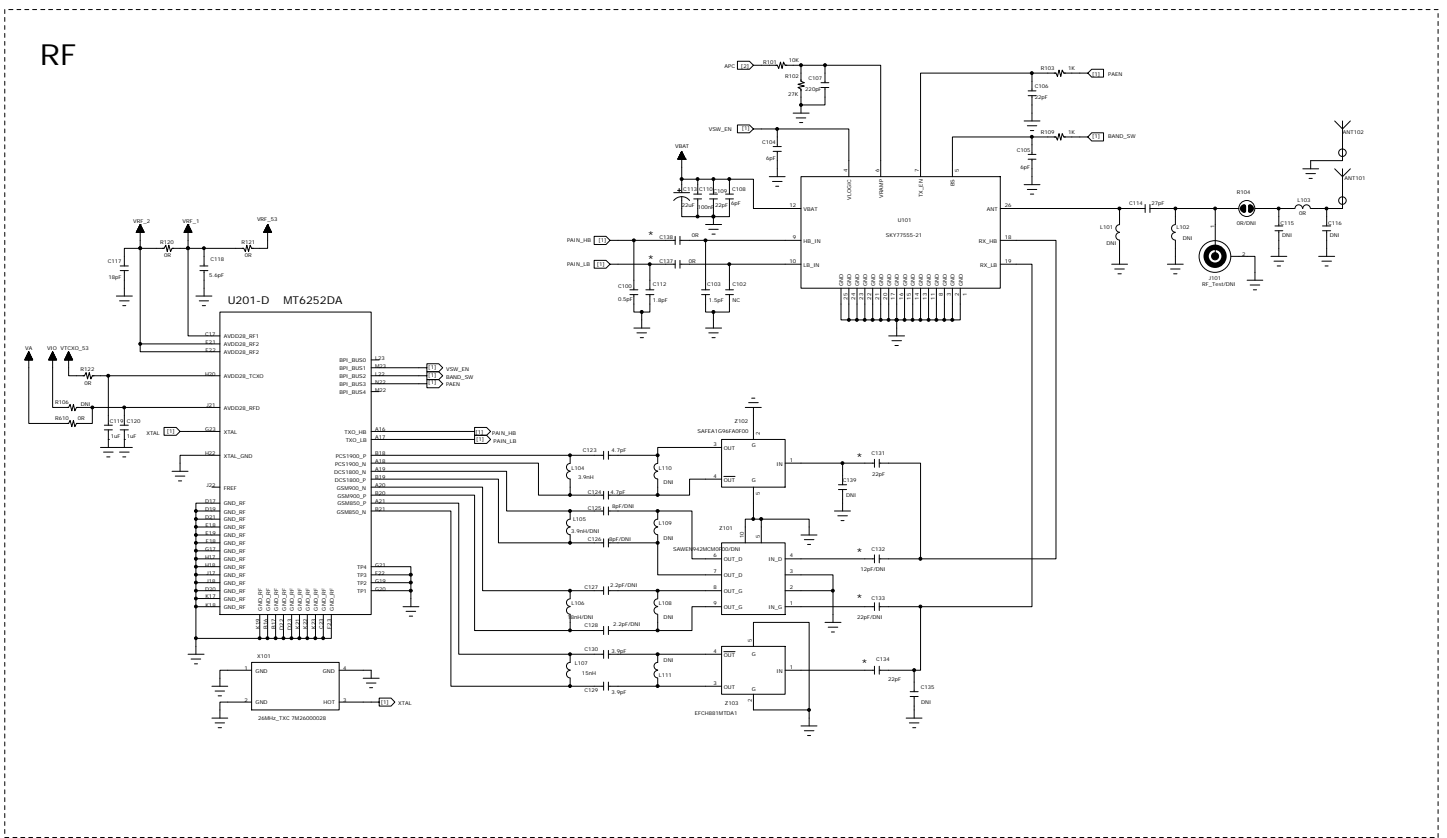

COMPANY: Smile-phone			
FILE: O1_RF			
DATE: 2011-9-14	SIZE: A2	REV: V0.1	
DRW: Leidajun	DATE: <Release Date>		
RELEASED: <Release Date>			SHEET: 1 / 8