

PMU-3 can be used for sleep mode

- EMPT0 : reserved
- EMPT1 : Gyro-Sensor
- EMPT2 : A/D-Sensor
- EMPT3 : G-Sensor
- EMPT4 : W-Sensor
- EMPT5 : CTB
- EMPT6 : MAGNET
- EMPT7 : MEM0
- EMPT8 : MEM129
- EMPT9 : MEM420 REF
- EMPT10 : MEM420 REF
- EMPT11 : MEM420 REF

PMU0 : 3D Control
 PMU1 : 3D Control
 PMU2 : 3D Control
 PMU3 : GP10 Mode

UART0 : Download
 UART1 : UART
 UART2 : UART
 UART3 : UART
 UART4 : Debug

I2C0 : G/M/GYRO sensor / CTB
 I2C1 : Camera
 I2C2 : PMIC

I2S0 : MEM1
 I2S1 : MEM620

MSDC0 : reserved
 MSDC1 : T-Card
 MSDC2 : GP10
 MSDC3 : MEM620

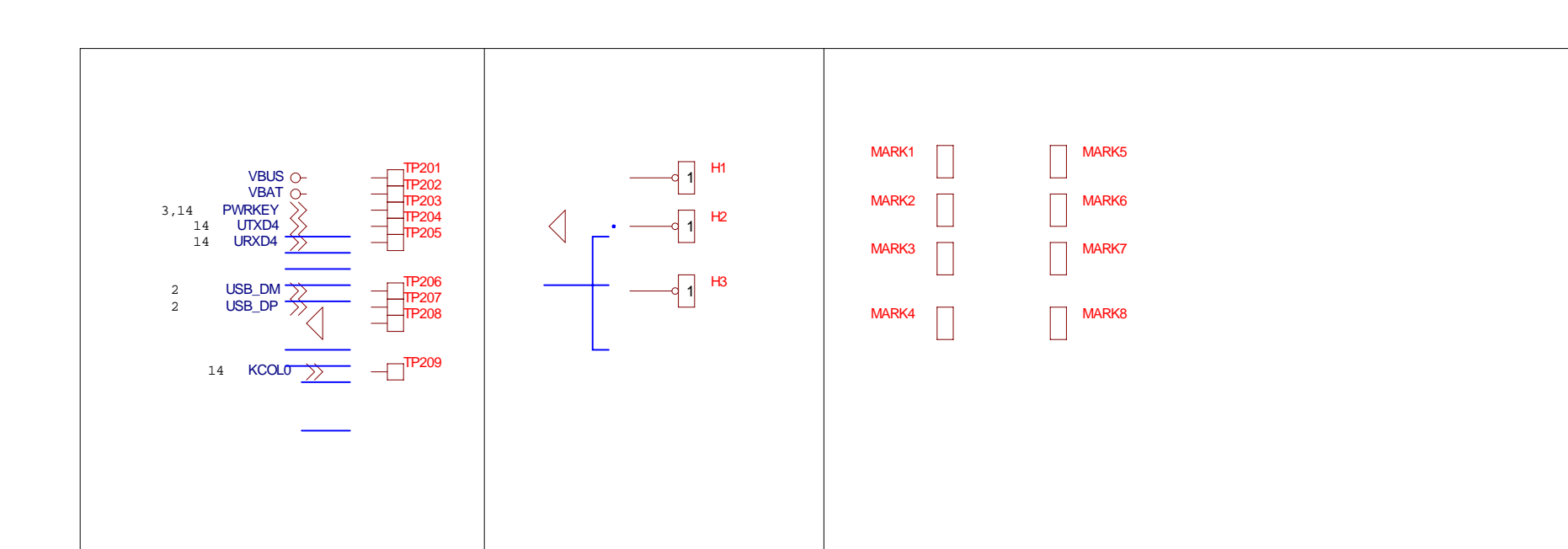
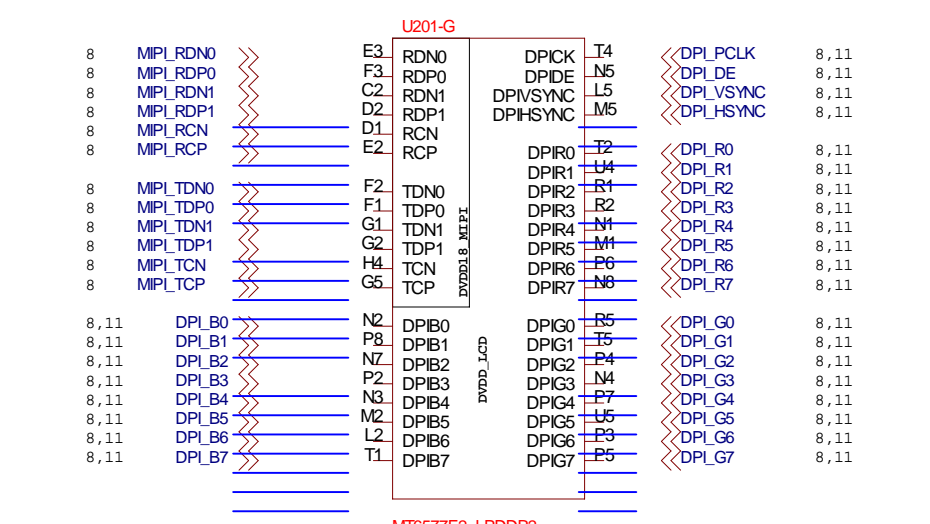
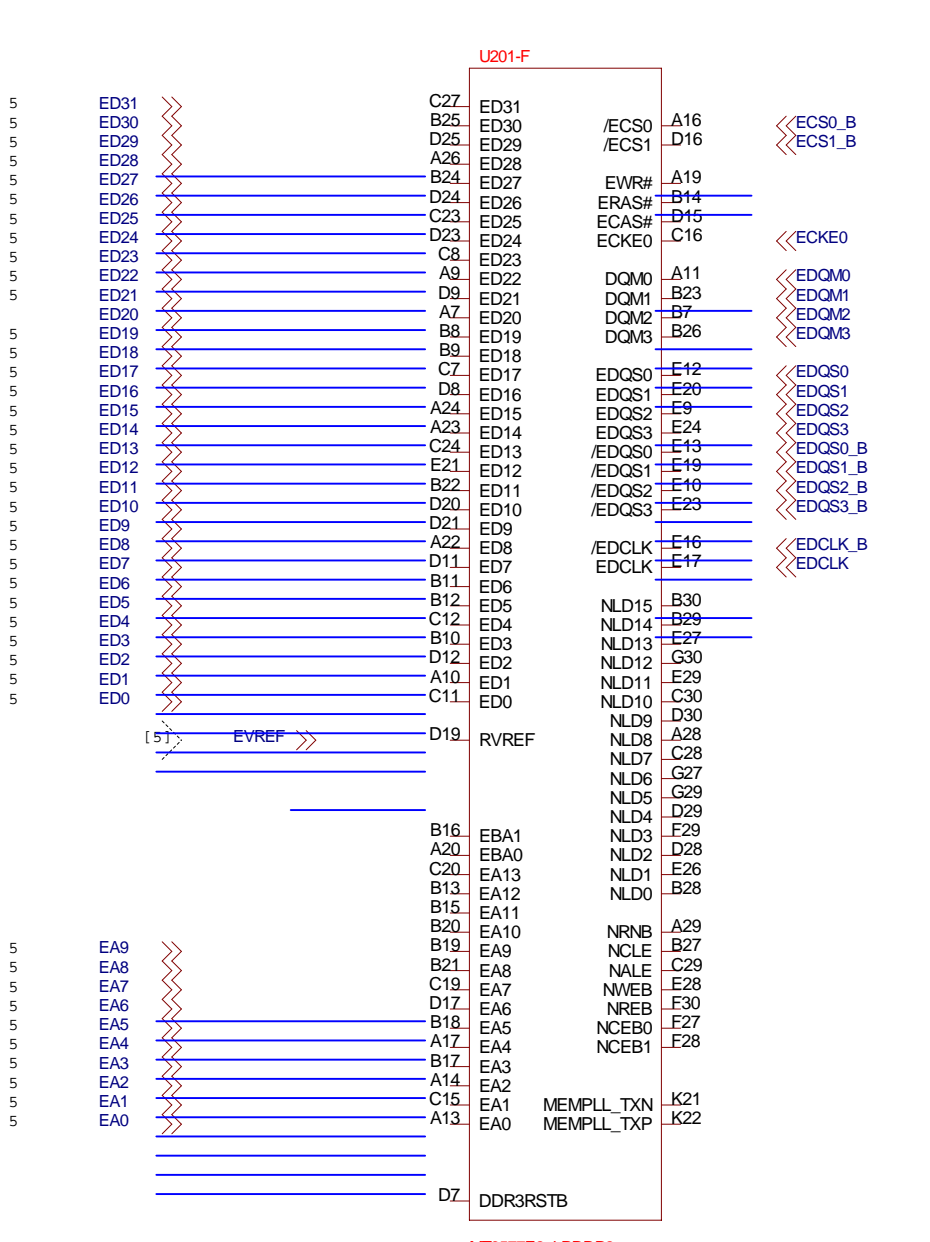
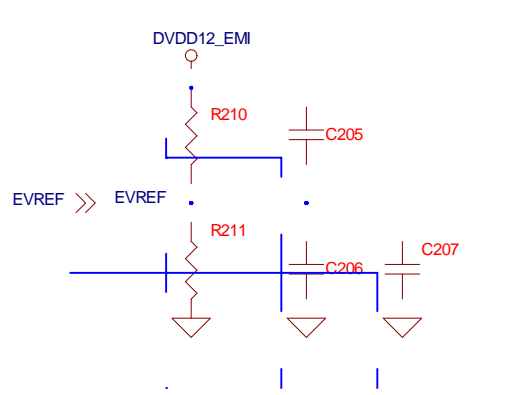

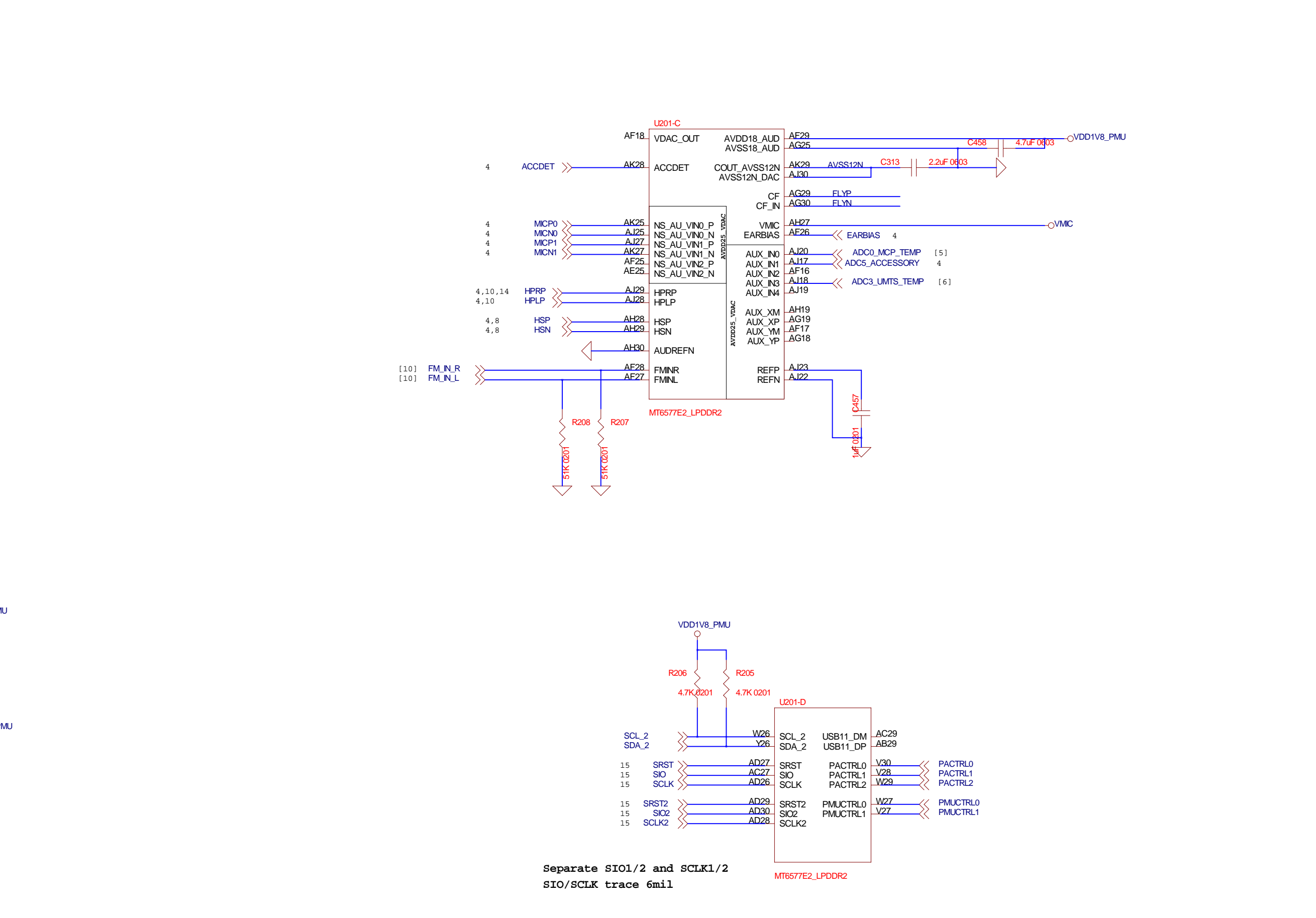
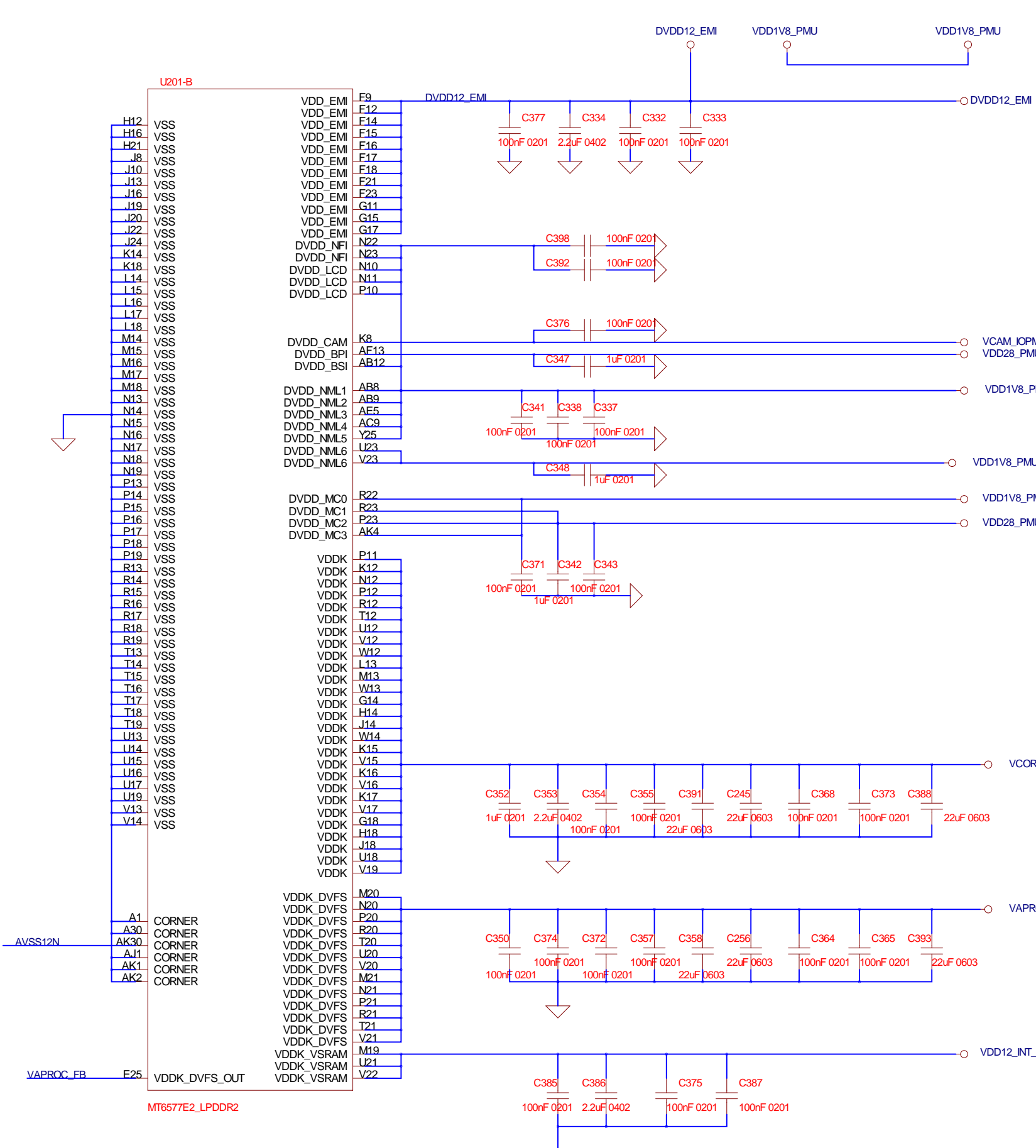
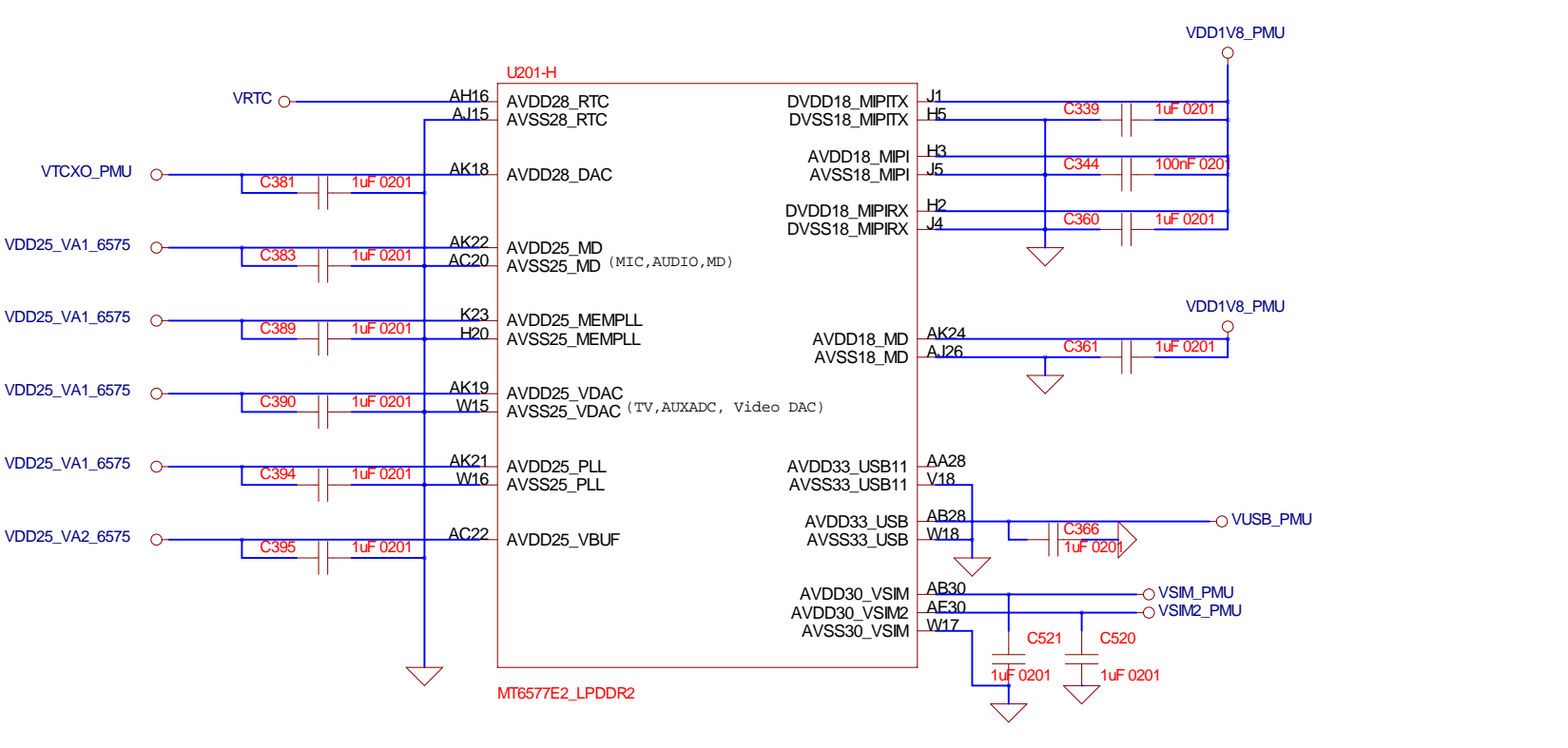
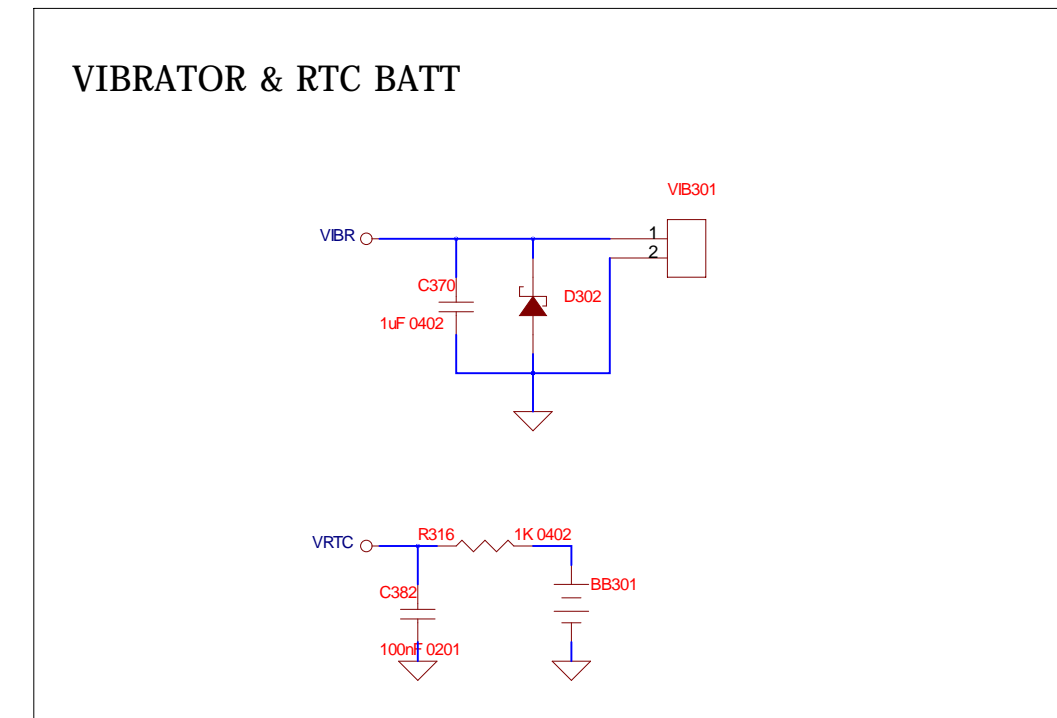
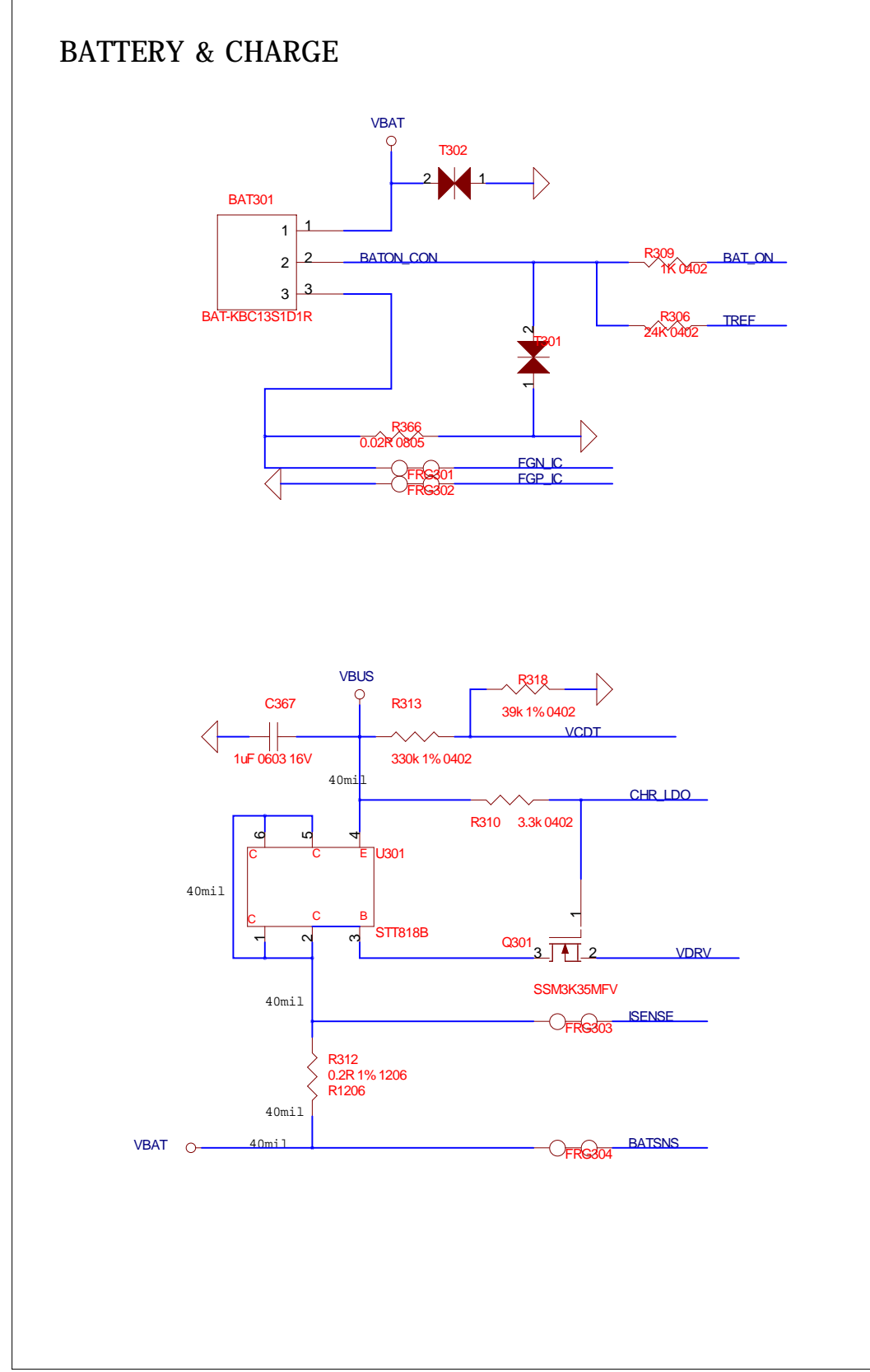
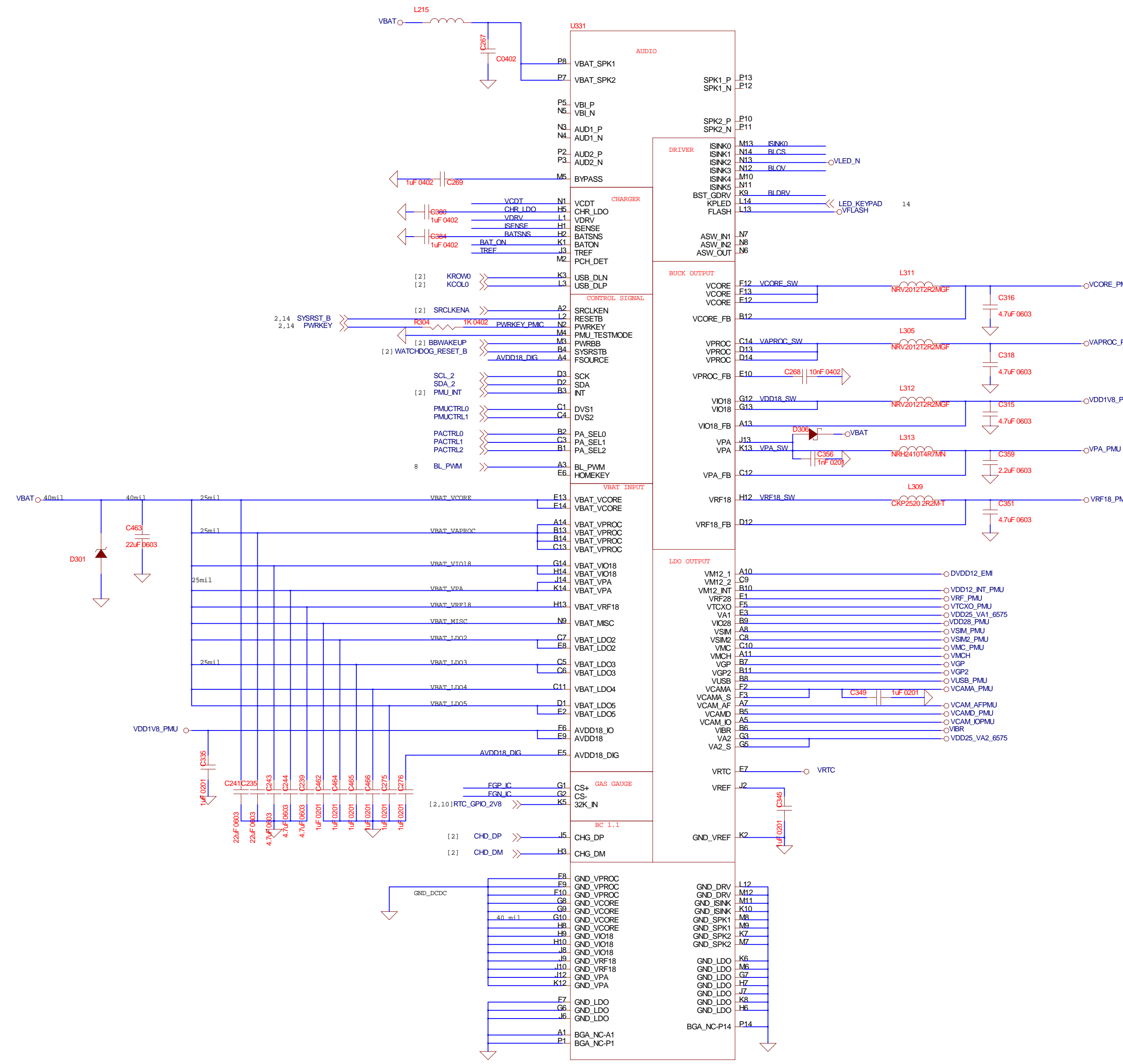

Separate S10/2 and S12/2 S10/S12 trace file!

MIC

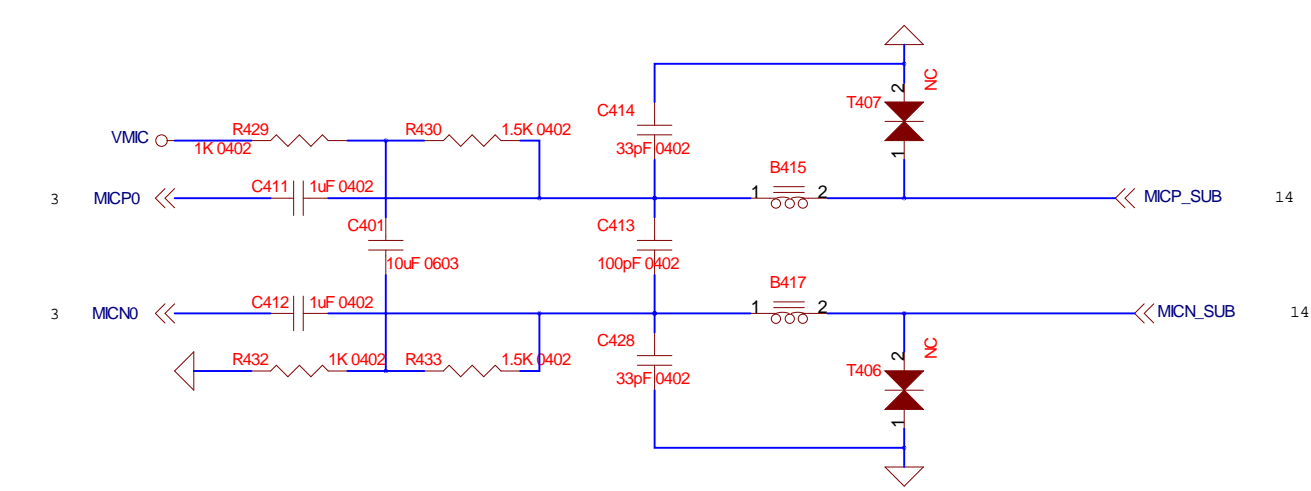

SPEAKER

RECEIVER

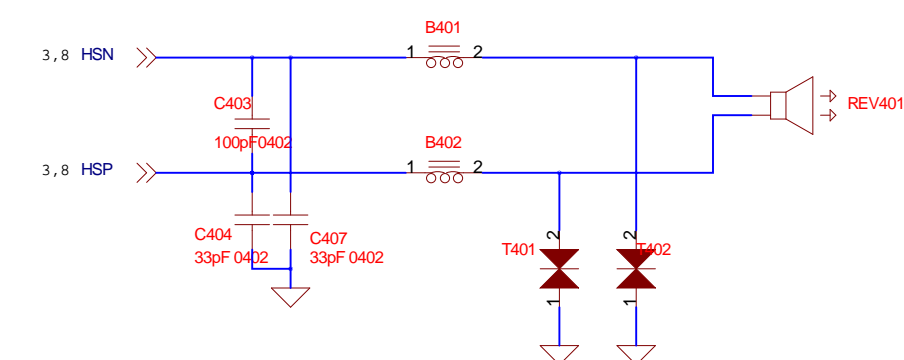

Audio Jack

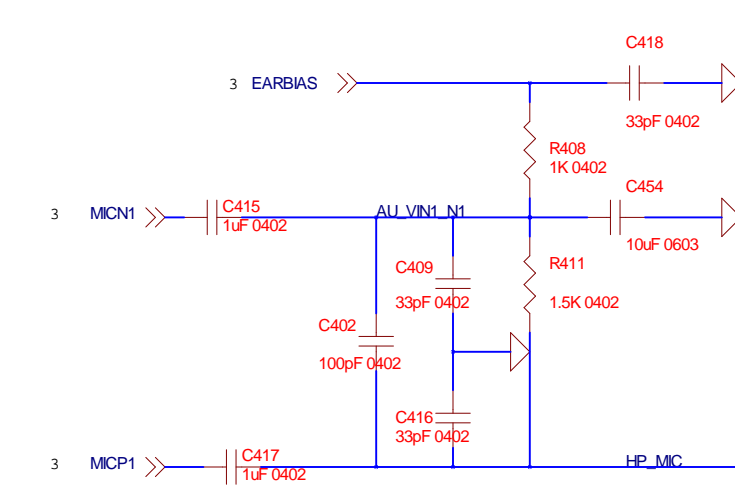
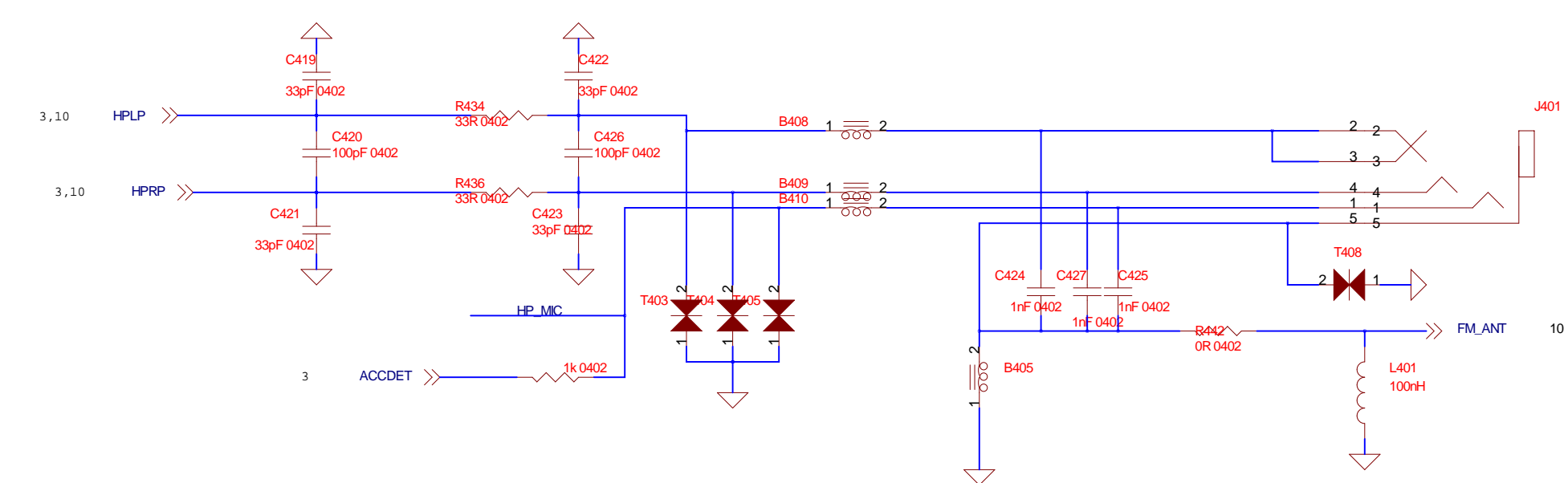

RF_MT6162_RX

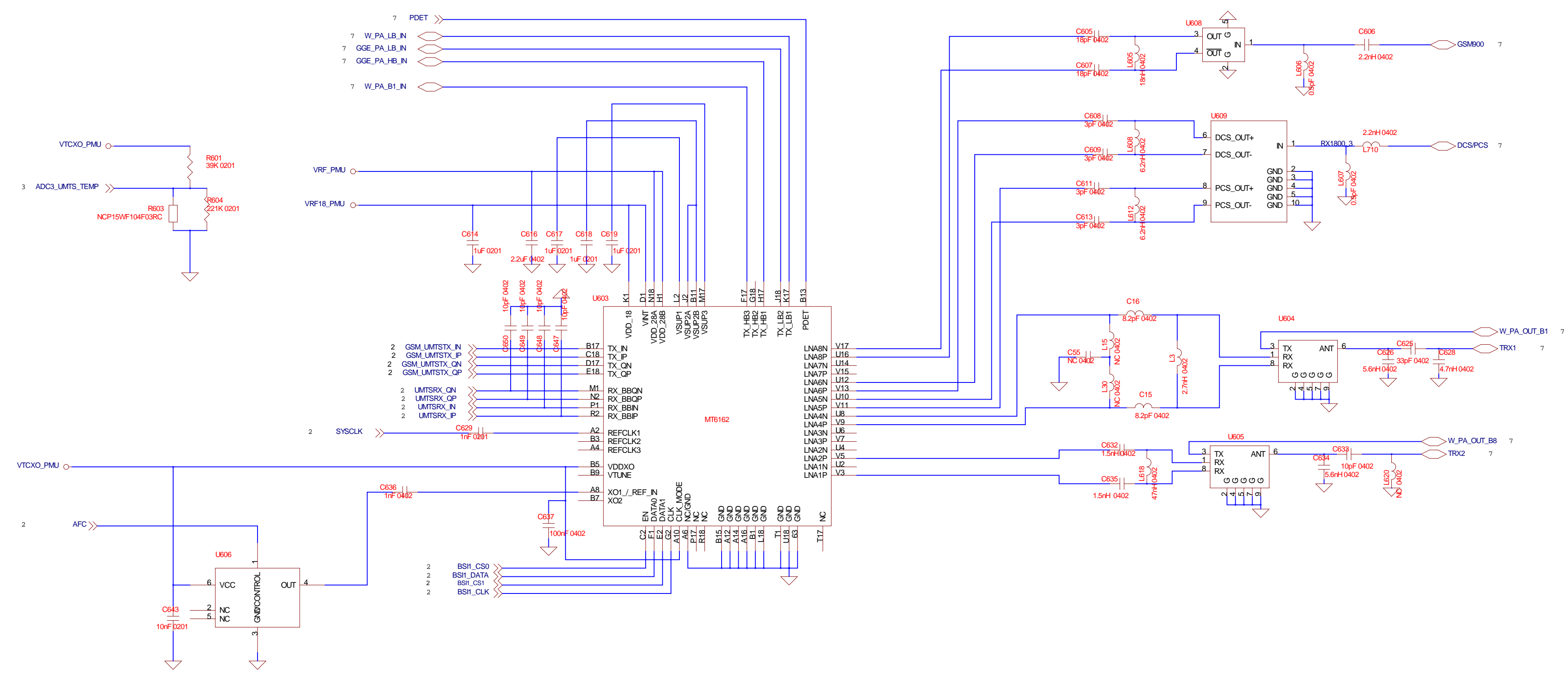

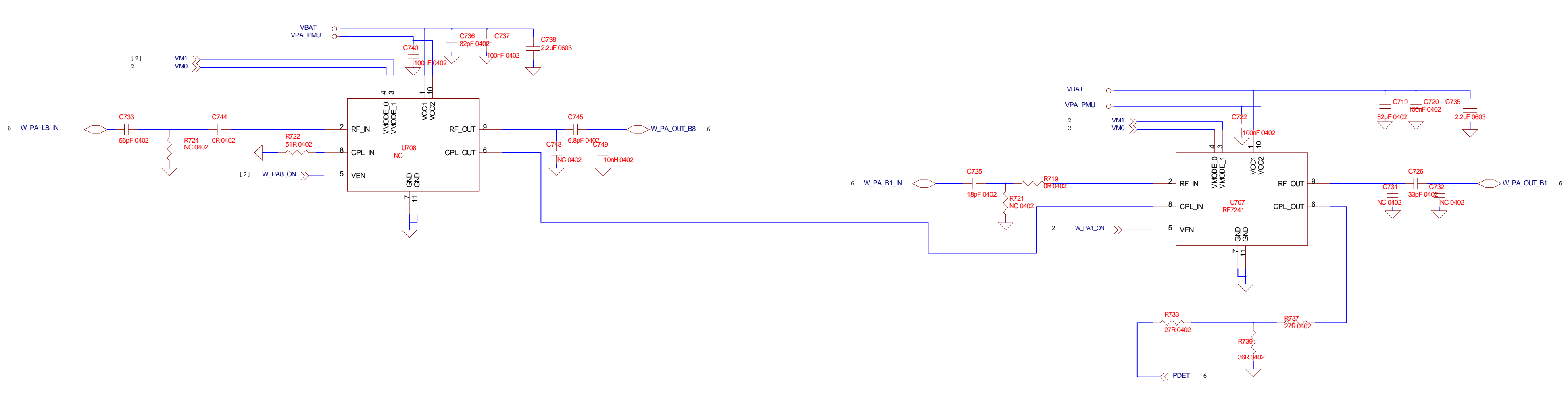
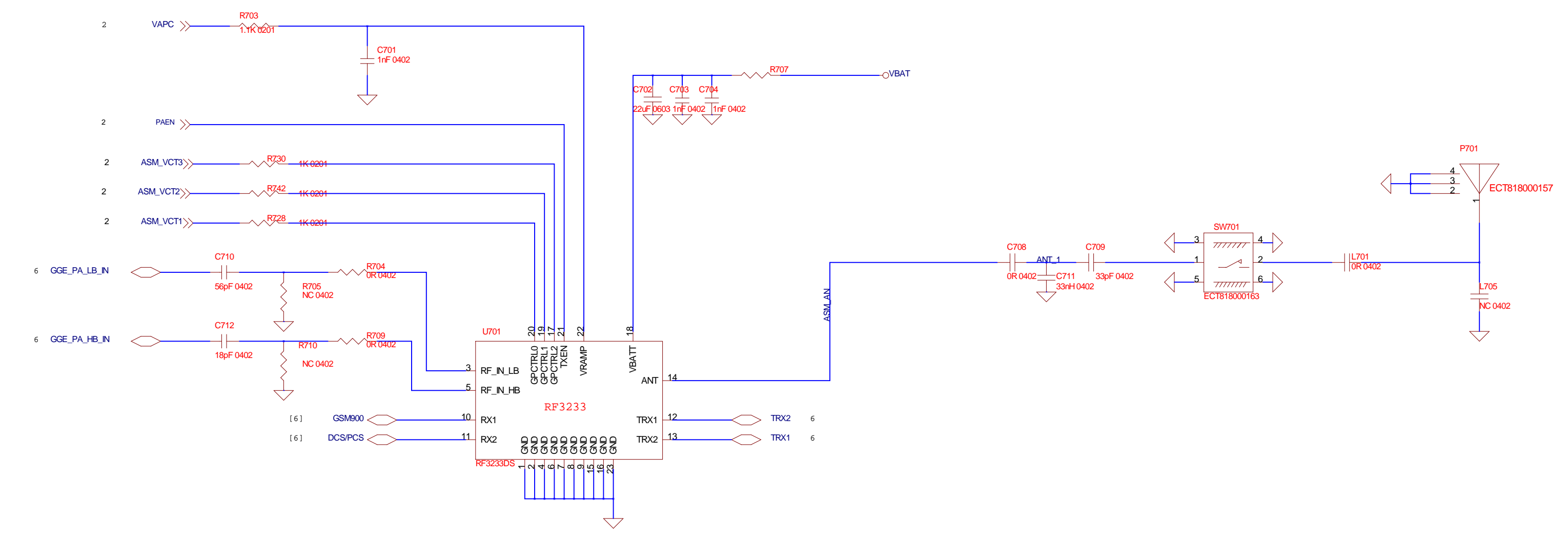

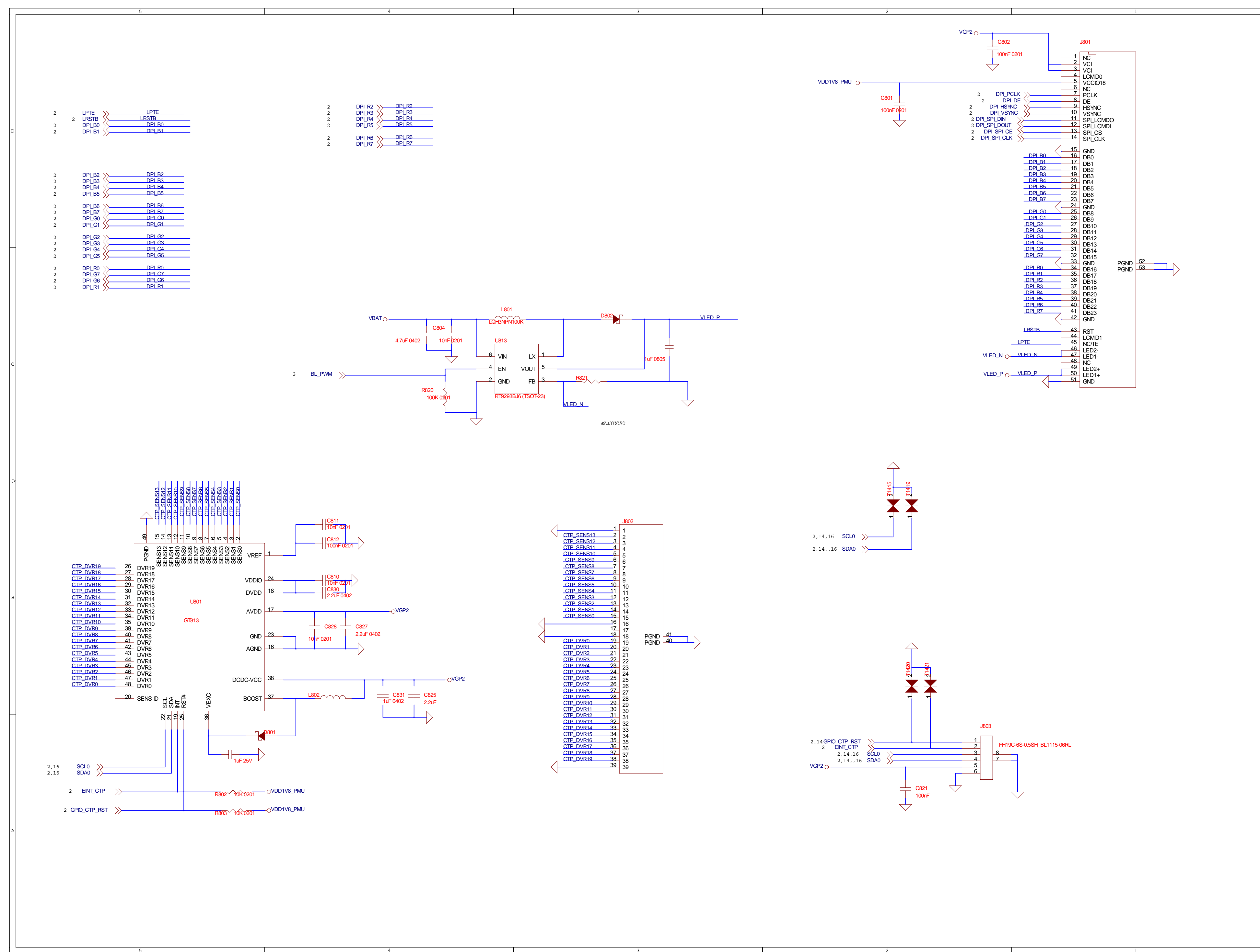

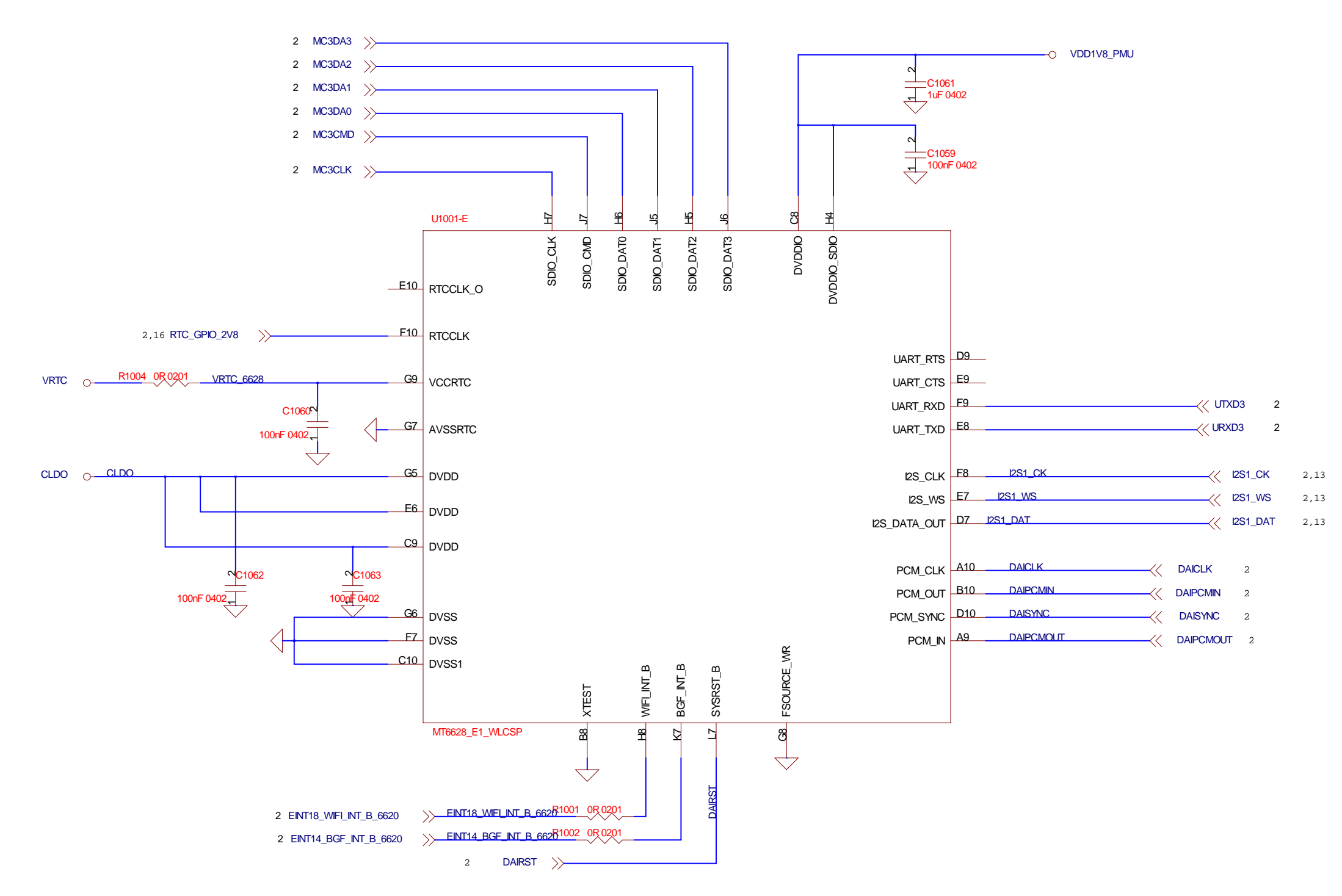
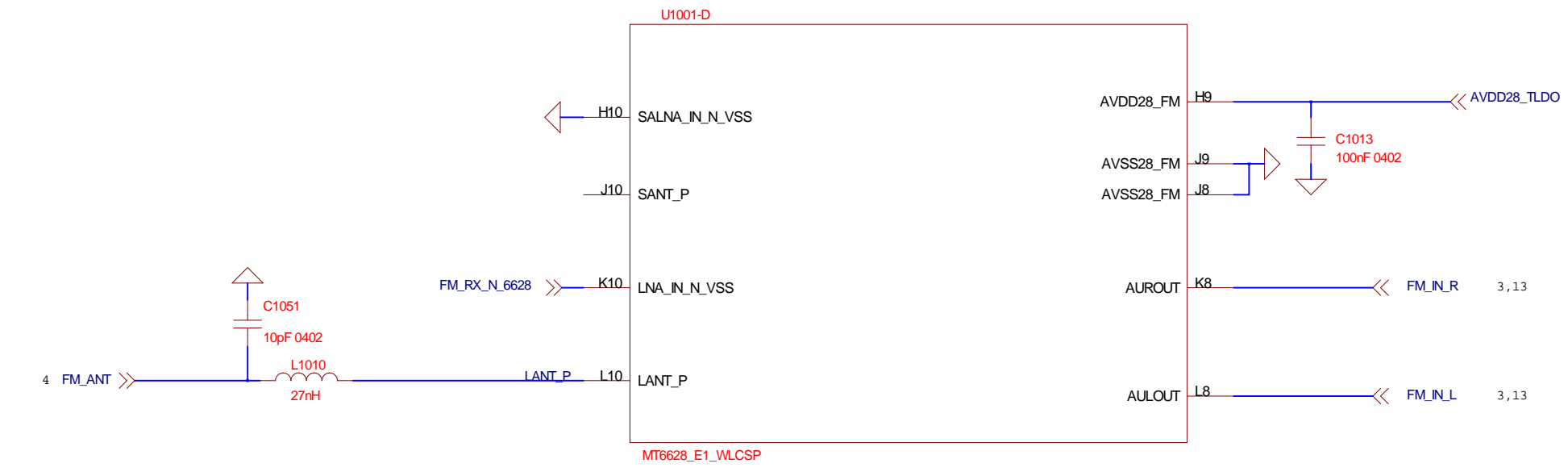
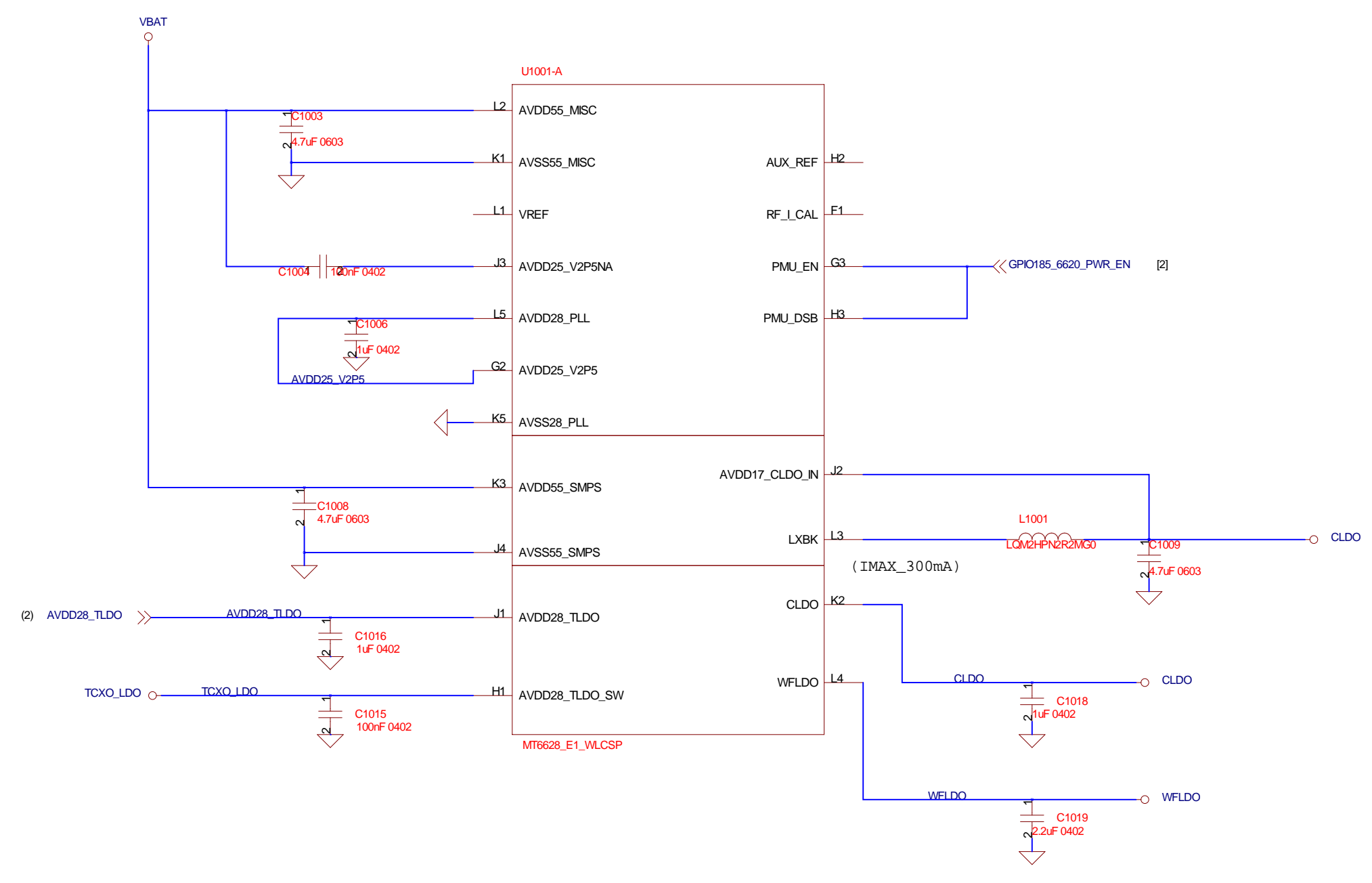
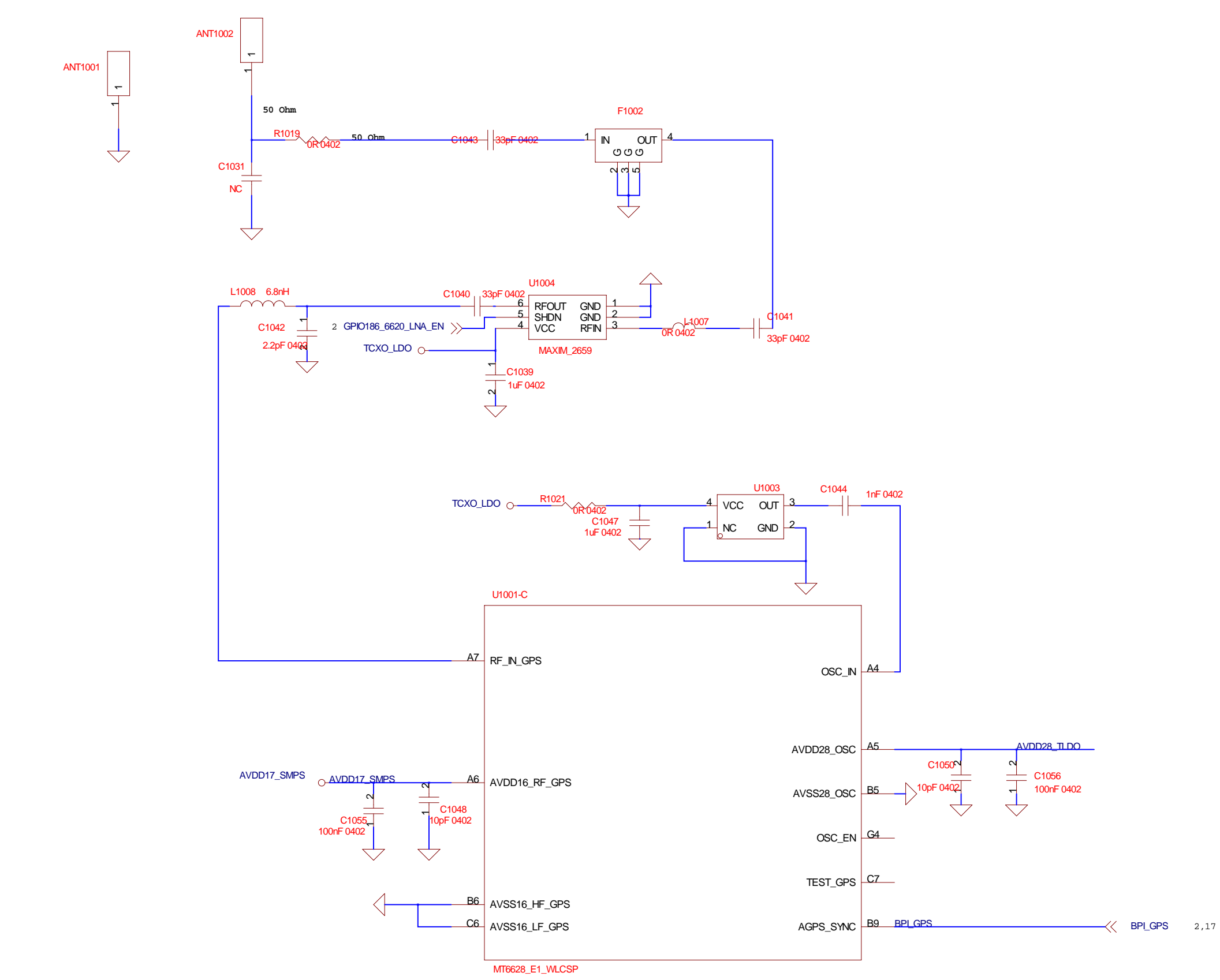
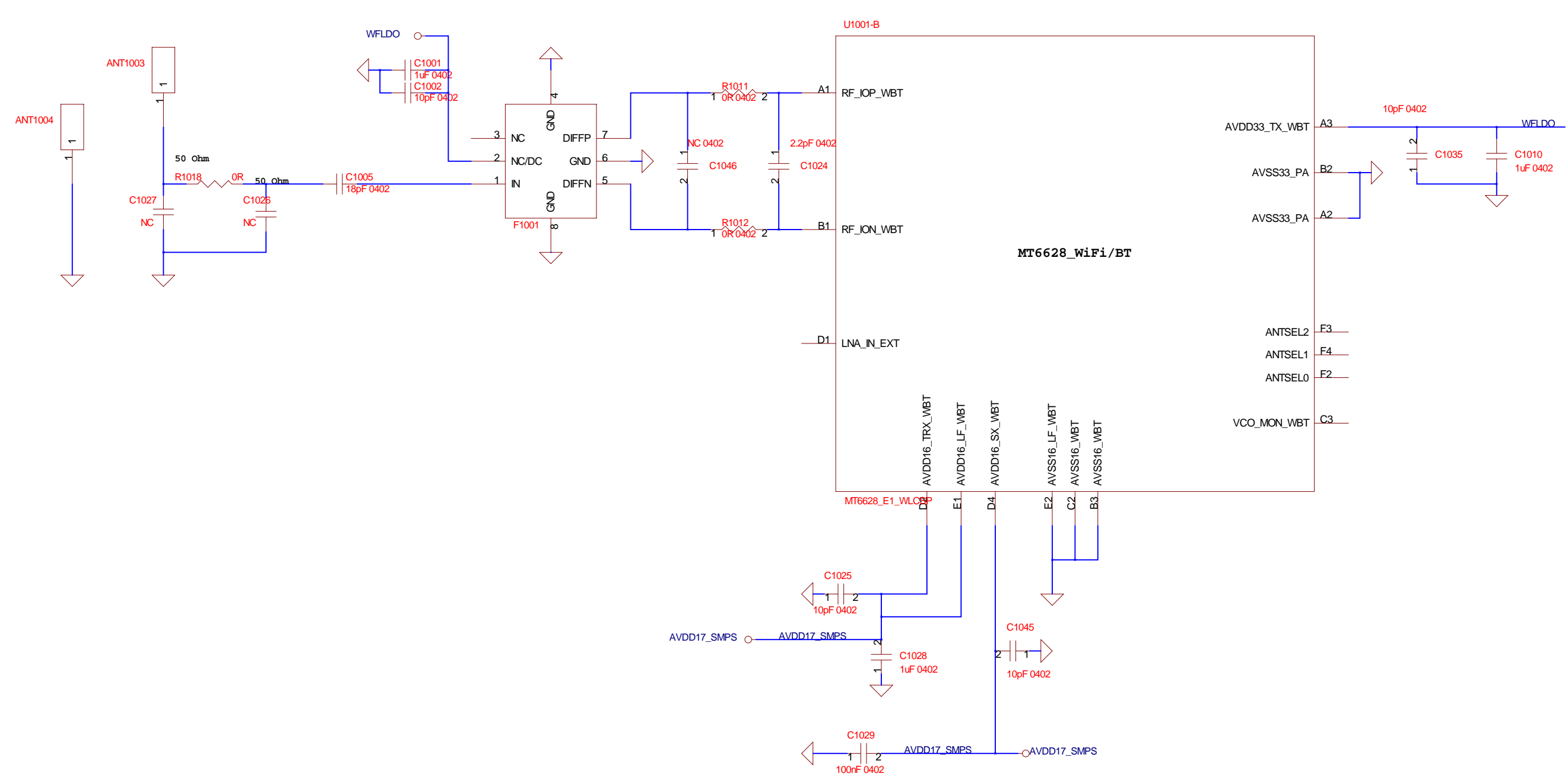

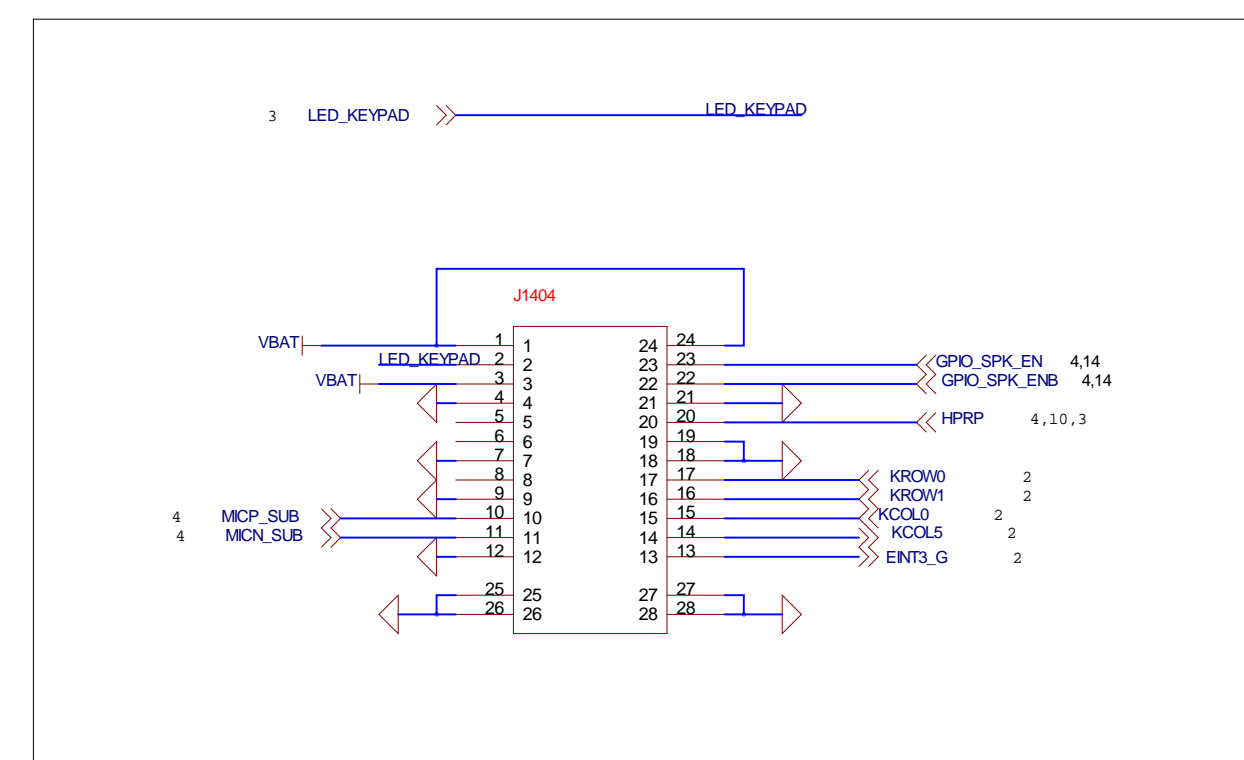
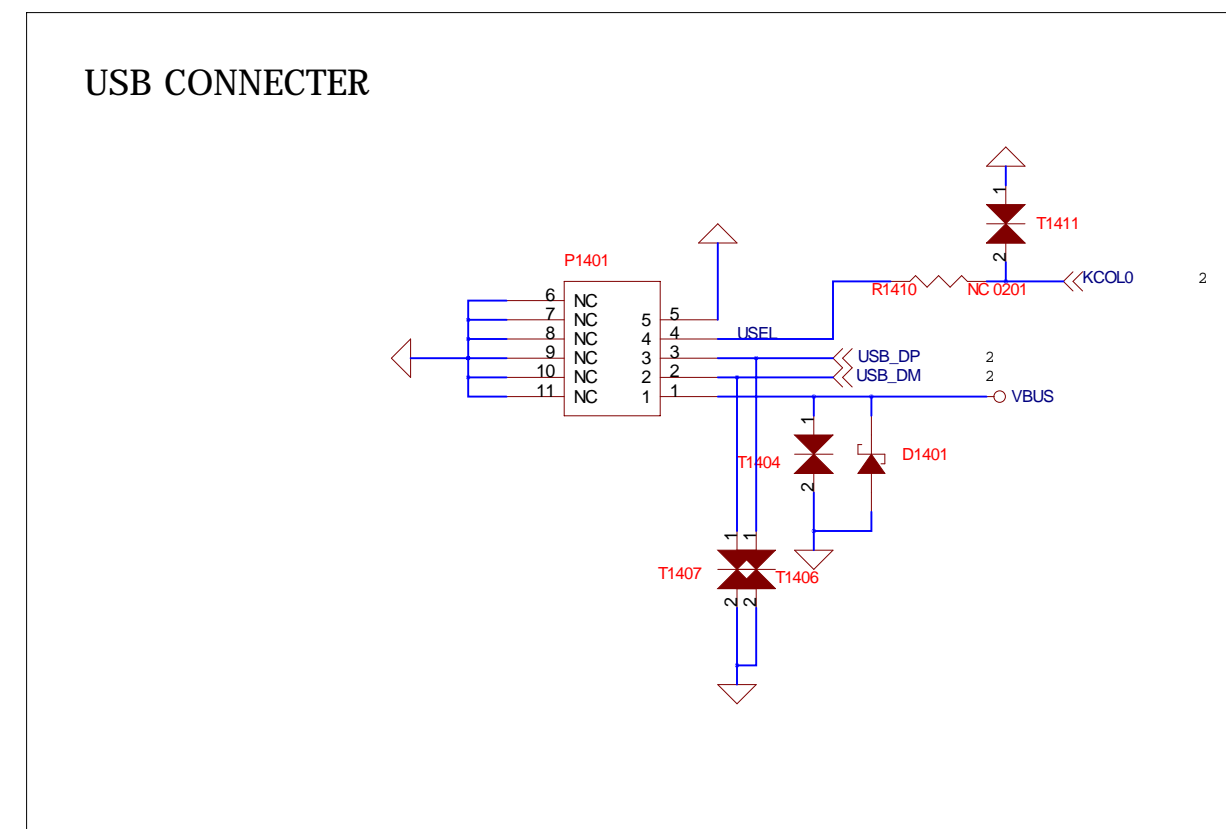
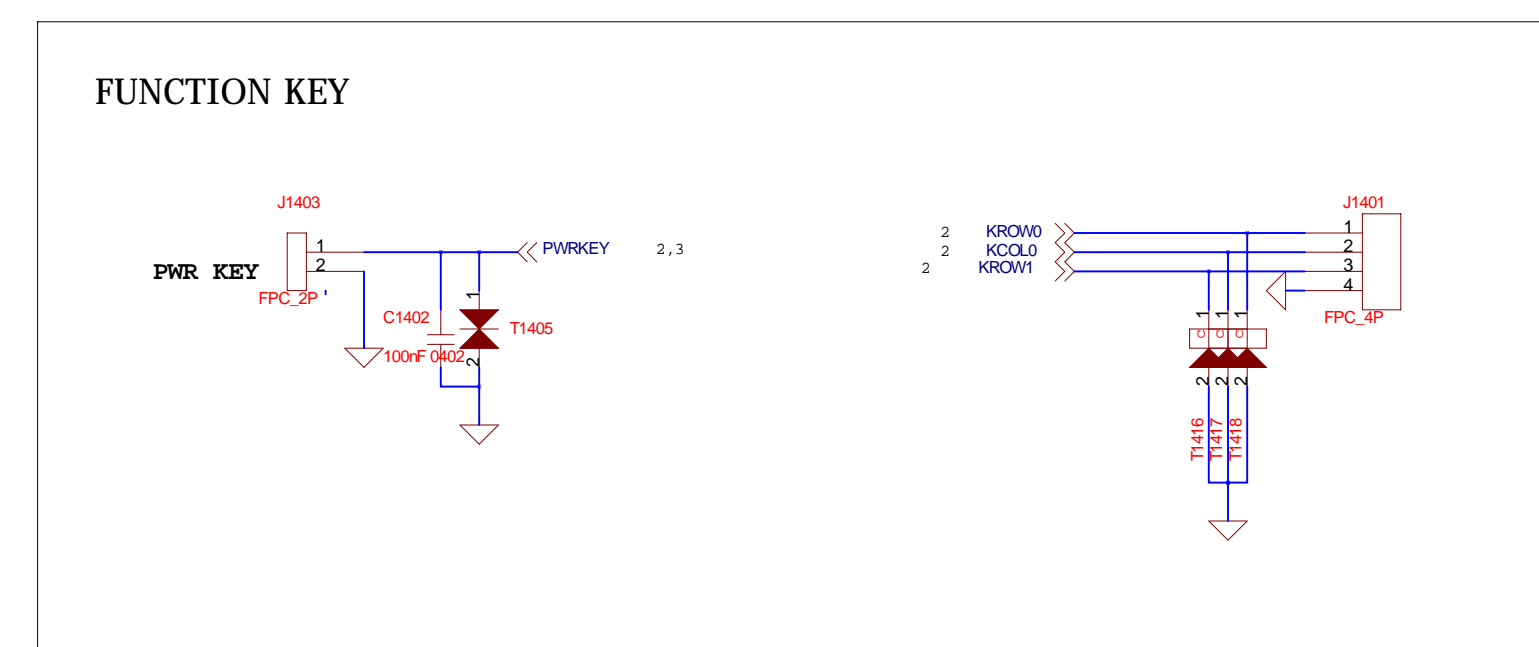
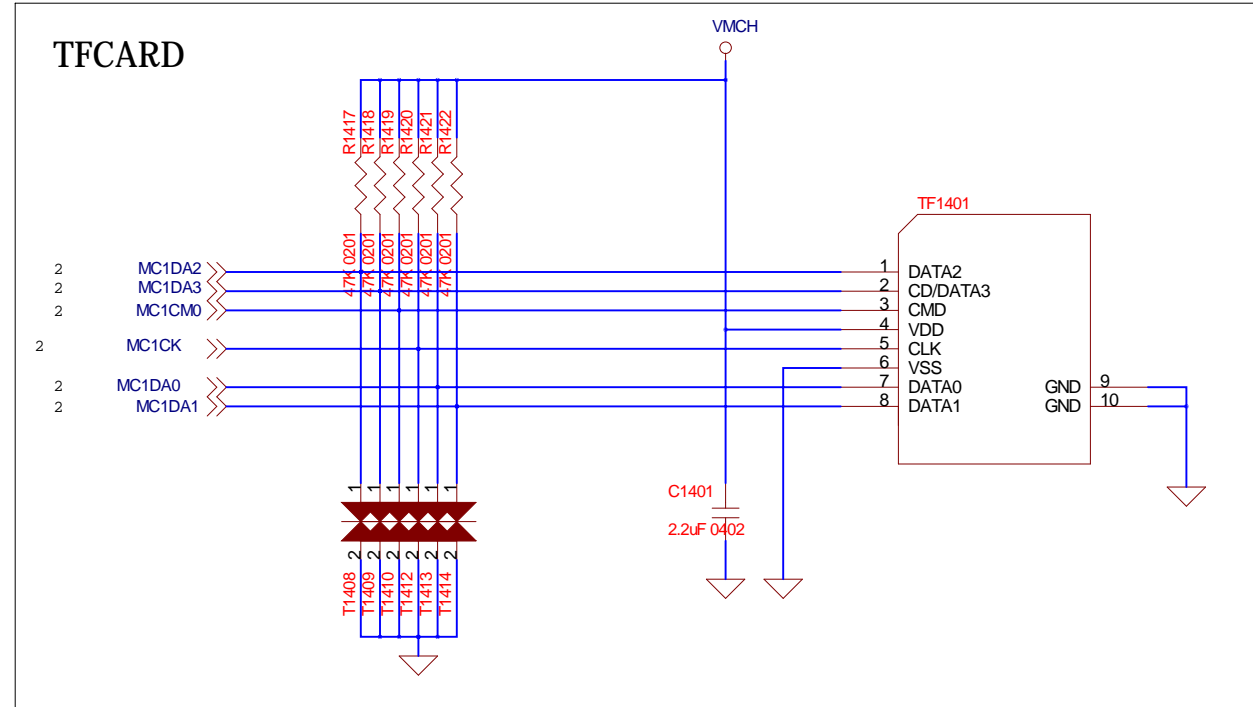

2.11 CMBCLK >> CMBCLK
 2.11 CMBST >> CMBCLK
 2 CMBPON >> CMBCLK

 2.11 CMBREF >> CMBREF
 2.11 CMBRE >> CMBREF
 2 CMBVTS >> CMBREF
 2 CMBVTS >> CMBREF

 2.11 CMBVTS >> CMBREF
 2.11 CMBVTS >> CMBREF
 2 CMBVTS >> CMBREF

 2.11 CMBVTS >> CMBREF
 2.11 CMBVTS >> CMBREF
 2.11 CMBVTS >> CMBREF

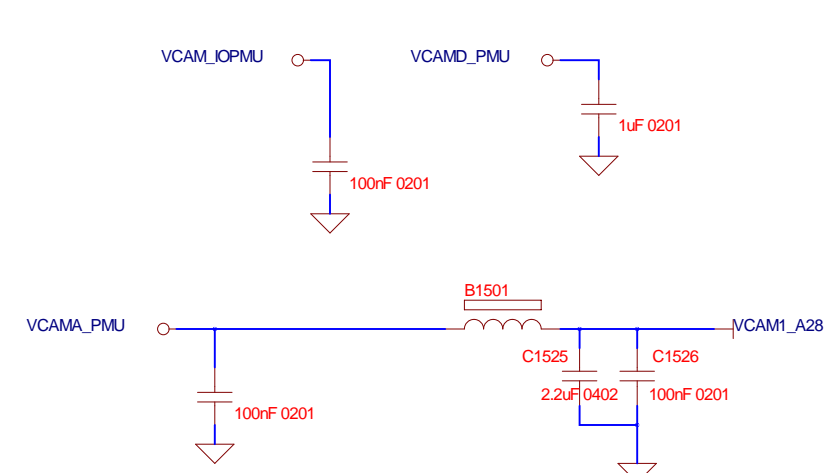

CAMERAε™ BACKε ©

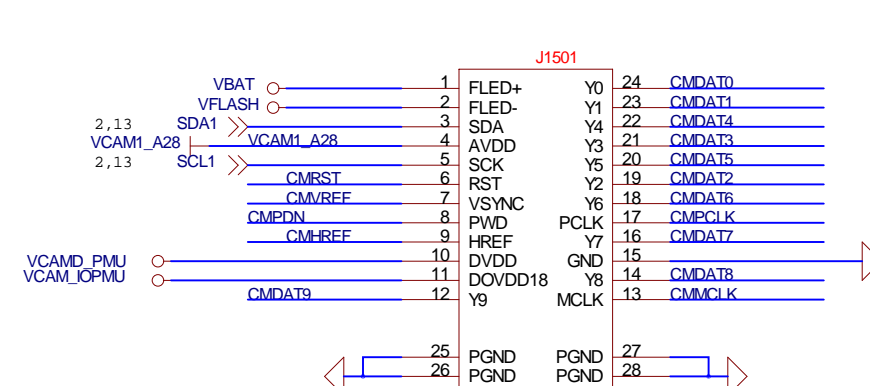

SIM1

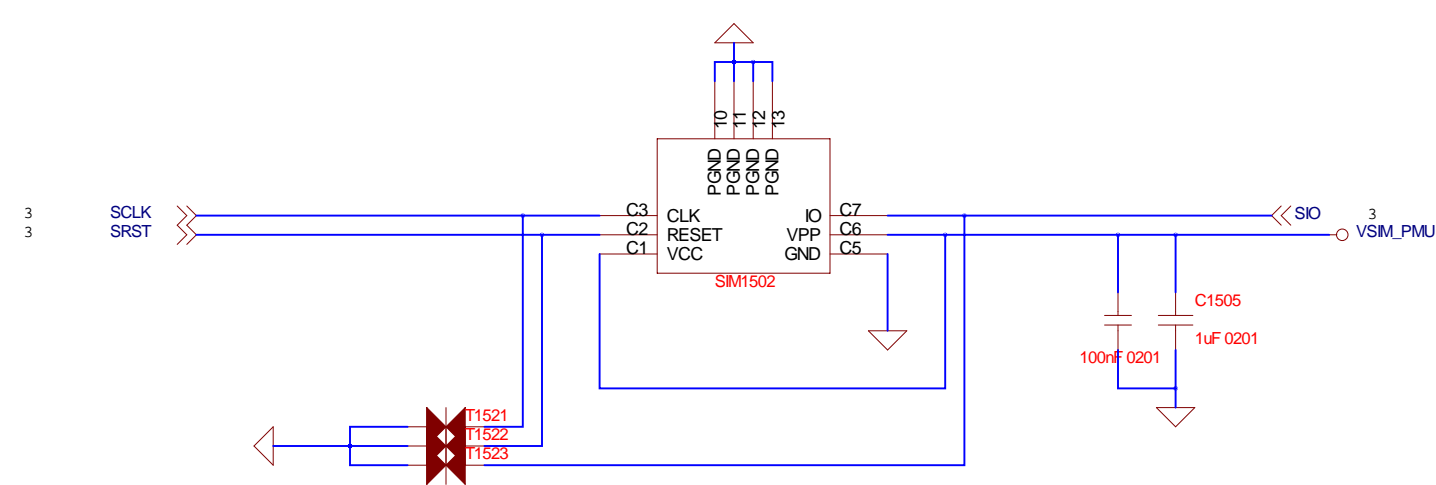

CAMERAε™ FRONTε ©

