

TEST REPORT

of

FCC PART 15 SUBPART E

New Application; Class I PC; Class II PC

Product : Wireless Router
Brand: Synology
Model: RT1900ac
Model Difference: N/A
FCC ID: YOR-RT1900AC
FCC Rule Part: §15.407, Cat:NII
Applicant: Synology Incorporated
Address: 3F-3,No.106,Chang An W. Rd., Taipei, Taiwan

Test Performed by:

International Standards Laboratory

<Lung-Tan LAB>

*Side Registration No.

BSMI: SL2-IN-E-0013; MRA TW1036; TAF: 0997; IC: IC4067B-3;

*Address:

No. 120, Lane 180, Hsin Ho Rd.

Lung-Tan Dist., Tao Yuan City 325, Taiwan

*Tel : 886-3-407-1718; Fax: 886-3-407-1738

Report No.: **ISL-15LR055FENII-R1**

Issue Date : **2015/08/24**

Test results given in this report apply only to the specific sample(s) tested and are traceable to national or international standard through calibration of the equipment and evaluating measurement uncertainty herein.

This report MUST not be used to claim product endorsement by TAF, NVLAP or any agency of the Government.

This test report shall not be reproduced except in full, without the written approval of International Standards Laboratory.



VERIFICATION OF COMPLIANCE

Applicant: Synology Incorporated
Product Description: Wireless Router
Brand Name: Synology
Model No.: RT1900ac
Model Difference: N/A
FCC ID: YOR-RT1900AC
FCC Rule Part: §15.407, Cat: NII
Date of test: 2015/03/13 ~ 2015/08/21
Date of EUT Received: 2015/03/13

We hereby certify that:

All the tests in this report have been performed and recorded in accordance with the standards described above and performed by an independent electromagnetic compatibility consultant, International Standards Laboratory.

The test results contained in this report accurately represent the measurements of the characteristics and the energy generated by sample equipment under test at the time of the test. The sample equipment tested as described in this report is in compliance with the limits of above standards.

Test By:	 _____	Date:	2015/08/24 _____
	<i>Dion Chang / Engineer</i>		
Prepared By:	 _____	Date:	2015/08/24 _____
	<i>Gigi Yeh / Specialist</i>		
Approved By:	 _____	Date:	2015/08/24 _____
	<i>Vincent Su / Technical Manager</i>		

Version

Version No.	Date	Description
00	2015/05/11	Initial creation of document
01	2015/08/24	Add Band 2, B3 and same type lower gain antenna

Table of Contents

1. GENERAL INFORMATION	6
1.1. Product Description	6
1.2. Related Submittal(s) / Grant (s)	8
1.3. Test Methodology	8
1.4. Test Facility	8
1.5. Special Accessories	8
1.6. Equipment Modifications	8
2. SYSTEM TEST CONFIGURATION	9
2.1. EUT Configuration	9
2.2. EUT Exercise	9
2.3. Test Procedure	9
2.4. Configuration of Tested System	10
3. SUMMARY OF TEST RESULT	11
4. DESCRIPTION OF TEST MODES	12
5. AVERAGE OUTPUT POWER / SPECTRAL DENSITY MEASUREMENT.....	13
5.1 Standard Applicable	13
5.2 Measurement Procedure.....	15
5.3 Measurement Equipment Used:	16
5.4 Measurement Equipment Used:	16
5.5 Measurement Result.....	17
6. 26dB /99% EMISSION BANDWIDTH MEASUREMENT	46
6.1 Standard Applicable	46
6.2 Measurement Procedure.....	46
6.3 Measurement Equipment Used:	46
6.4 Test Set-up:	46
6.5 Measurement Result.....	47
7. UNDESIRABLE EMISSION - RADICTED MEASUREMENT	62
7.1 Standard Applicable	62
7.2 EUT Setup.....	64
7.3 Measurement Procedure.....	65
7.4 Test SET-UP (Block Diagram of Configuration)	66
7.5 Measurement Equipment Used:	67
7.6 Field Strength Calculation	68
7.7 Measurement Result.....	68
8. TRANSMISSION IN THE ABSENCE OF DATA	89
8.1 Standard Applicable	89
8.2 Result:	89

9. FREQUENCY STABILITY	90
9.1 Standard Applicable	90
9.2 Result:	90
10. ANTENNA REQUIREMENT	91
10.1 Standard Applicable	91
10.2 Antenna Connected Construction	91
11. TPC and DFS MEASUREMENT	92
11.1 TPC: Standard Applicable.....	92
11.2 DFS: Standard Applicable.....	92
11.3 Test Equipment Used:	98
11.4 Test results	98

1. GENERAL INFORMATION

1.1. Product Description

General:

Product Name	Wireless Router	
Brand Name	Synology	
Model Name	RT1900ac	
Model Difference	N/A	
TPC	Yes	
DFS	DFS Master	
Simultaneous transmissions:	Yes, 2.4GHz and 5GHz	
WAN Port:	One provided	
LAN Port:	Four provided, 10/100/1000Mbps	
HW version:	V1.6	
SW version:	V5740	
Power Supply	12Vdc from AC adapter	
	Adapter:	Model: WA-24E12

The device is an indoor access point.

WLAN Band 2(5250-5350MHz) and Band 3(5470-5725MHz) : 3X3 MIMO

5600-5650MHz is excluded.

Wi-Fi	Frequency Range (MHz)	Channels	Average Rated Power at each port	Modulation Technology
802.11a	5250 – 5350 (NII)	4	8.12dBm (AVG)	OFDM
802.11an	HT20 5250 – 5350 (NII)	4	12.61dBm (AVG)	
	HT40 5250 - 5350 (NII)	2	12.07dBm (AVG)	
802.11ac	HT80 5250 - 5350 (NII)	1	10.96dBm (AVG)	

Wi-Fi	Frequency Range (MHz)	Channels	Average Rated Power at each port	Modulation Technology
802.11a	5470 - 5725 (NII)	9	8.87dBm (AVG)	OFDM
802.11an	HT20 5470 - 5725 (NII)	9	13.95dBm (AVG)	
	HT40 5470 - 5725 (NII)	4	13.25dBm (AVG)	
802.11ac	HT80 5470 - 5725 (NII)	2	12.43dBm (AVG)	
Modulation type		CCK, DQPSK, DBPSK for DSSS 256QAM, 64QAM, 16QAM, QPSK, BPSK for OFDM		
Antenna Designation		<p>Dipole Antenna 1: Reversed SMA type, Supplier: anjiesz 2.4GHz Antenna : 3.63dBi (max) 5GHz Antenna : 6.12dBi (max)</p> <p>Dipole Antenna 2: Reversed SMA type, Supplier: ADVANCED 2.4GHz Antenna : 3.5dBi 5GHz Antenna : 4.6dBi</p> <p>According to KDB662911 D01 MU-MIMO signals could be considered uncorrelated for purposes of directional gain computation. 3Tx MIMO, Beamforming gain: 4.77dBi = 10log(3)</p>		

Power Tolerance: 2 dB

The EUT is compliance with IEEE 802.11 a/b/g/n/ac Standard.

This is CIIPC report what applies for frequency bands: 5250 MHz -5350MHz; 5470MHz–5725MHz (5600-5650MHz is excluded).

Remark: The above DUT's information was declared by manufacturer. Please refer to the specifications or user's manual for more detailed description.

1.2. Related Submittal(s) / Grant (s)

This submittal(s) (test report) is intended for **FCC ID: YOR-RT1900AC** filing to comply with Section 15.407 of the FCC Part 15, Subpart E Rules. The composite system (digital device) is compliance with Subpart B is authorized under a DoC procedure.

1.3. Test Methodology

Both conducted and radiated testing were performed according to the procedures in ANSI C63.10: 2013. Radiated testing was performed at an antenna to EUT distance 3 meters.

KDB Document: 789033 D02 General UNII Test Procedures New Rules v01

KDB 644545 D03 GUIDANCE FOR IEEE Std 802.11ac

KDB 662911 D01 GUIDANCE FOR MIMO Device

KDB 905462 GUIDANCE FOR DFS Test

FCC 14-30 Revision UNII

594280 D02 U-NII Device Security v01r02

1.4. Test Facility

The measurement facilities used to collect the 3m Radiated Emission and AC power line conducted data are located on the address of International Standards Laboratory <Lung-Tan LAB> No. 120, Lane 180, Hsin Ho Rd., Lung-Tan Dist., Tao Yuan City 325, Taiwan which are constructed and calibrated to meet the FCC requirements in documents ANSI C63.4: 2014, ANSI C63.10: 2013. FCC Registration Number is: 872200; Designation Number is: TW1036, Canada Registration Number: 4067B-3.

1.5. Special Accessories

Not available for this EUT intended for grant.

1.6. Equipment Modifications

Not available for this EUT intended for grant.

2. SYSTEM TEST CONFIGURATION

2.1. EUT Configuration

The EUT configuration for testing is installed on RF field strength measurement to meet the Commissions requirement and operating in a manner which intends to maximize its emission characteristics in a continuous normal application.

2.2. EUT Exercise

The EUT (Transmitter) was operated in the engineering mode to fix the Tx frequency that was for the purpose of the measurements.

2.3. Test Procedure

2.3.1 Conducted Emissions

The EUT is a placed on as turn table which is 0.8 m above ground plane. According to the requirements in Section Section 5 and 7 of ANSI C63.10: 2013. Conducted emissions from the EUT measured in the frequency range between 0.15 MHz and 30 MHz using CISPR Quasi-Peak and Average detector mode.

2.3.2 Radiated Emissions

The EUT is a placed on as turn table which is 0.8 m /1.5m(Frequency above 1GHz) above ground plane. The turn table shall rotate 360 degrees to determine the position of maximum emission level. EUT is set 3m away from the receiving antenna which varied from 1m to 4m to find out the highest emission. And also, each emission was to be maximized by changing the polarization of receiving antenna both horizontal and vertical. In order to find out the max. emission, the relative positions of this hand-held transmitter (EUT) was rotated through three orthogonal axes and measurement procedures for electric field radiated emissions above 1 GHz the EUT measurement is to be made “while keeping the antenna in the ‘cone of radiation’ from that area and pointed at the area both in azimuth and elevation, with polarization oriented for maximum response.” Is still within the 3Db illumination BW of the measurement antenna. According to the requirements in Section 6 and 11 of ANSI C63.10: 2013.

2.4. Configuration of Tested System

Fig. 2-1 Configuration of Tested System

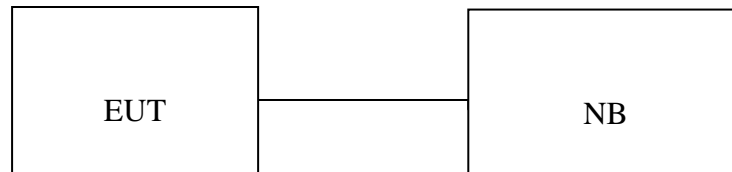

Table 1-1 Equipment Used in Tested System

Item	Equipment	Mfr/Brand	Model/ Type No.	Series No.	Data Cable	Power Cord
1	NB	HP	440	N/A	N/A	No- Shielding

3. SUMMARY OF TEST RESULT

FCC Rules	Description Of Test	Result
§15.407(a)(2)	Average Output Power/ Spectral Density Measurement	Compliant
§15.407(a)	26dB/99% Emission Bandwidth	Compliant
§15.407(b)	Undesirable Emission – Radiated Measurement	Compliant
§15.407(c)	Transmission in case of Absence of Information	Compliant
§15.407(g)	Frequency Stability	Compliant
§15.407(a)	Antenna Requirement	Compliant
§15.407(h)	TPC and DFS Measurement	Compliant
§15.407(i)	Device Security	Compliant

4. DESCRIPTION OF TEST MODES

The EUT has been tested under operating condition.

Test program used to control the EUT for staying in continuous transmitting mode is programmed.

5250MHz-5350MHz:

802.11a mode: Channel low (5260MHz)、 mid (5280MHz) and high (5320MHz) with 6Mbps lowest data rate are chosen for pre-test testing of radiated emissions.

802.11 n HT20: Channel low (5260MHz)、 mid (5280MHz) and high (5320MHz) with 6.5Mbps lowest data rate are chosen for pre-test testing of radiated emissions.

802.11 n HT40: Channel low (5270MHz) and high (5310MHz) with 13.5Mbps lowest data rate are chosen for pre-test testing of radiated emissions.

802.11 AC HT80: Channel (5290MHz) with 29.3Mbps lowest data rate is chosen for pre-test testing of radiated emissions.

The worst case 802.11 n HT20 (5GHz) was reported for Radiated Emission.

5470MHz-5725MHz:

802.11a mode: Channel low (5500MHz)、 mid (5580MHz) and high (5720MHz) with 6Mbps lowest data rate are chosen for pre-test testing of radiated emissions.

802.11 n HT20: Channel low (5500MHz)、 mid (5580MHz) and high (5720MHz) with 6.5Mbps lowest data rate are chosen for pre-test testing of radiated emissions.

802.11 n HT40: Channel low (5510MHz) 、 mid (5550MHz) and high (5710MHz) with 13.5Mbps lowest data rate are chosen for pre-test testing of radiated emissions.

802.11 AC HT80: Channel low (5530MHz) and high (5690MHz)with 29.3Mbps lowest data rate is chosen for pre-test testing of radiated emissions.

The worst case 802.11 n HT20 (5GHz) was reported for Radiated Emission.

5. AVERAGE OUTPUT POWER / SPECTRAL DENSITY MEASUREMENT

5.1 Standard Applicable

According to §15.407(a) Power limits:

(1) For the band 5.15-5.25 GHz.

(i) For an outdoor access point operating in the band 5.15 – 5.25 GHz, the maximum conducted output power over the frequency band of operation shall not exceed 1 W provided the maximum antenna gain does not exceed 6 dBi. In addition, the maximum power spectral density shall not exceed 17 dBm in any 1 megahertz band. If transmitting antennas of directional gain greater than 6 dBi are used, both the maximum conducted output power and the maximum power spectral density shall be reduced by the amount in dB that the directional gain of the antenna exceeds 6 dBi. The maximum e.i.r.p. at any elevation angle above 30 degrees as measured from the horizon must not exceed 125 mW (21 dBm).

(ii) For an indoor access point operating in the band 5.15 – 5.25 GHz, the maximum conducted output power over the frequency band of operation shall not exceed 1 W provided the maximum antenna gain does not exceed 6 dBi. In addition, the maximum power spectral density shall not exceed 17 dBm in any 1 megahertz band. If transmitting antennas of directional gain greater than 6 dBi are used, both the maximum conducted output power and the maximum power spectral density shall be reduced by the amount in dB that the directional gain of the antenna exceeds 6 dBi.

(iii) For fixed point-to-point access points operating in the band 5.15 – 5.25 GHz, the maximum conducted output power over the frequency band of operation shall not exceed 1 W. Fixed point-to-point U-NII devices may employ antennas with directional gain up to 23 dBi without any corresponding reduction in the maximum conducted output power or maximum power spectral density. For fixed point-to-point transmitters that employ a directional antenna gain greater than 23 dBi, a 1 dB reduction in maximum conducted output power and maximum power spectral density is required for each 1 dB of antenna gain in excess of 23 dBi. Fixed, point-to-point operations exclude the use of point-to-multipoint systems, omnidirectional applications, and multiple collocated transmitters transmitting the same information. The operator of the U-NII device, or if the equipment is professionally installed, the installer, is responsible for ensuring that systems employing high gain directional antennas are used exclusively for fixed, point-to-point operations.

(iv) For mobile and portable client devices in the 5.15 – 5.25 GHz band, the maximum conducted output power over the frequency band of operation shall not exceed 250 mW provided the maximum antenna gain does not exceed 6 dBi. In addition, the maximum power spectral density shall not exceed 11 dBm in any 1 megahertz band. If transmitting antennas of directional gain greater than 6 dBi are used, both the maximum conducted output power and the maximum power spectral density shall be reduced by the amount in dB that the directional gain of the antenna exceeds 6 dBi.

(2) For the 5.25-5.35 GHz and 5.47-5.725 GHz bands, the maximum conducted output power over the frequency bands of operation shall not exceed the lesser of 250 mW or $11 \text{ dBm} + 10 \log B$, where B is the 26 dB emission bandwidth in megahertz. In addition, the maximum power spectral density shall not exceed 11 dBm in any 1 megahertz band. If transmitting antennas of directional gain greater than 6 dBi are used, both the maximum conducted output power and the maximum power spectral density shall be reduced by the amount in dB that the directional gain of the antenna exceeds 6 dBi.

(3) For the band 5.725-5.85 GHz, the maximum conducted output power over the frequency band of operation shall not exceed 1 W. In addition, the maximum power spectral density shall not exceed 30 dBm in any 500 kHz band. If transmitting antennas of directional gain greater than 6 dBi are used, both the maximum conducted output power and the maximum power spectral density shall be reduced by the amount in dB that the directional gain of the antenna exceeds 6 dBi. However, fixed point-to-point U-NII devices operating in this band may employ transmitting antennas with directional gain greater than 6 dBi without any corresponding reduction in transmitter conducted power. Fixed, point-to-point operations exclude the use of point-to-multipoint systems, omnidirectional applications, and multiple collocated transmitters transmitting the same information. The operator of the U-NII device, or if the equipment is professionally installed, the installer, is responsible for ensuring that systems employing high gain directional antennas are used exclusively for fixed, point-to-point operations.

NOTE TO PARAGRAPH (a)(3): The Commission strongly recommends that parties employing U-NII devices to provide critical communications services should determine if there are any nearby Government radar systems that could affect their operation.

5.2 Measurement Procedure

For Average Power

1. Place the EUT on the table and set it in transmitting mode.
2. Remove the antenna from the EUT and then connect a low loss RF cable from the antenna port to the power meter
3. Record the max. reading.
4. Repeat above procedures until all frequency measured were complete.

For Peak Power Spectral Density

1. Place the EUT on the table and set it in transmitting mode.
2. Remove the antenna from the EUT and then connect a low loss RF cable from the antenna port to Spectrum.
3. Set RBW=1MHz,VBW=3MHz, Span=50MHz (Base Mode), Sweep time = Auto, traces 100 sweeps of video averaging for 5150-5725MHz;
4. Set RBW=500KHz,VBW=1.5MHz, Span=60MHz (Base Mode), Sweep time = Auto, traces 100 sweeps of video averaging for 5725-5850MHz;
5. Record the max. reading.
6. Repeat above procedures until all frequency measured were complete.

Refer to section E3 of KDB Document: KDB 789033 D02 General UNII Test Procedures New Rules v01

5.3 Measurement Equipment Used:

Conducted Emission Test Side					
EQUIPMENT TYPE	MFR	MODEL NUMBER	SERIAL NUMBER	LAST CAL.	CAL DUE.
Power Meter 05	Anritsu	ML2495A	1116010	07/29/2015	07/28/2016
Power Sensor 05	Anritsu	MA2411B	34NKF50	07/29/2015	07/28/2016
Power Sensor 06	DARE	RPR3006W	13I00030SN O33	10/31/2014	10/30/2015
Power Sensor 07	DARE	RPR3006W	13I00030SN O34	10/31/2014	10/30/2015
Temperature Chamber	KSON	THS-B4H100	2287	06/05/2015	06/04/2016
DC Power supply	ABM	8185D	N/A	07/16/2015	07/15/2016
AC Power supply	EXTECH	CFC105W	NA	12/27/2014	12/26/2015
Attenuator	Woken	Watt-65m3502	11051601	NA	NA
Splitter	MCLI	PS4-199	12465	12/27/2013	12/26/2015
Spectrum analyzer	Agilent	N9030A	MY51360021	05/02/2015	05/01/2016

5.4 Measurement Equipment Used:

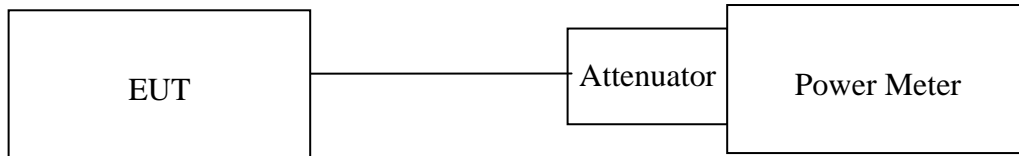

5.5 Measurement Result

Average Power Measurement:

Band: 5250-5350 MHz / 5470 – 5725 MHz

802.11a

Mode	Freq(MHz)	AV Power (dBm)	limit(dBm)	result
802.11a	5260	7.56	23.85	pass
	5280	7.90	23.85	pass
	5320	8.12	23.85	pass
	5500	8.87	23.85	pass
	5580	8.64	23.85	pass
	5720	7.91	23.85	pass

Note: 1. offset 0.5 dB for cable loss.

2. 5GHz antenna gain is 6.12dBi, the limit is reduced 0.12 dB.

3*3 MIMO

Mode	Freq(MHz)	Output Chain (dBm)			Combine Output Power (dBm)	Limit(dBm)	Result
		Chain A	chain B	Chain C			
n20	5260	7.81	8.03	6.71	12.33	19.08	Pass
	5280	7.9	8.11	6.96	12.46	19.08	Pass
	5320	8.14	8.23	7.04	12.61	19.08	Pass
	5500	9.15	9.37	8.03	13.66	19.08	Pass
	5580	9.41	9.67	8.34	13.95	19.08	Pass
	5720	8.81	9.02	7.74	13.33	19.08	Pass

3*3 MIMO

Mode	Freq(MHz)	Output Chain (dBm)			Combine Output Power (dBm)	Limit(dBm)	Result
		Chain A	chain B	Chain C			
n40	5270	7.42	7.68	6.35	11.96	19.08	Pass
	5310	7.59	7.77	6.42	12.07	19.08	Pass
	5510	8.43	8.64	7.32	12.94	19.08	Pass
	5550	8.76	8.94	7.62	13.25	19.08	Pass
	5710	8.14	8.36	7.04	12.66	19.08	Pass

3*3 MIMO

Mode	Freq(MHz)	Output Chain (dBm)			Combine Output Power (dBm)	Limit(dBm)	Result
		Chain A	chain B	Chain C			
AC80	5290	6.41	6.68	5.37	10.96	19.08	Pass
	5530	7.51	8.74	6.43	12.43	19.08	Pass
	5690	7.01	8.19	5.88	11.90	19.08	Pass

Note: 1. offset 0.5 dB for cable loss.

2. 5GHz antenna gain is 6.12dBi, Beamforming gain:4.77dBi , the limit is reduced 4.89 dB.

Band 3 (5470 – 5725 MHz) Highest channel power within band 4

802.11a

Mode	Channel	power (dBm)	limit(dBm)	result
	5720	4.04	29.88	pass

Note: 1. offset 0.5 dB for cable loss.

2. 5GHz antenna gain is 6.12dBi, the limit is reduced 0.12 dB.

3*3 MIMO

Mode	Freq(MHz)	Output Chain (dBm)			Combine Output Power (dBm)	Limit(dBm)	Result
		Chain A	chain B	Chain C			
n20	5720	-1.66	-1.53	-1.55	3.19	25.11	Pass

Mode	Freq(MHz)	Output Chain (dBm)			Combine Output Power (dBm)	Limit(dBm)	Result
		Chain A	chain B	Chain C			
n40	5710	-1.68	-1.57	-1.63	3.14	25.11	Pass

Mode	Freq(MHz)	Output Chain (dBm)			Combine Output Power (dBm)	Limit(dBm)	Result
		Chain A	chain B	Chain C			
AC80	5690	-1.66	-1.57	-1.63	3.15	25.11	Pass

Note: 1. offset 0.5 dB for cable loss.

2. 5GHz antenna gain is 6.12dBi, Beamforming gain:4.77dBi , the limit is reduced 4.89 dB.

Peak Power Spectral Density Measurement:

802.11a Mode

Frequency MHz	RF Power Density Reading (dBm/MHz)	Maximum Limit (dBm/MHz)
5260	-1.505	10.88
5280	-3.052	10.88
5320	-2.145	10.88
5500	-2.212	10.88
5580	-1.732	10.88
5720	-0.792	10.88

Note: 1. offset 0.5 dB for cable loss.

2. 5GHz antenna gain is 6.12dBi, the limit is reduced 0.12 dB.

3*3 MIMO

802.11n HT20					
Frequency MHz	Chain 1 RF Power Density Reading (dBm/MHz)	Chain 2 RF Power Density Reading (dBm/MHz)	Chain 3 RF Power Density Reading (dBm/MHz)	RF Power Density Reading (dBm/MHz)	Maximum Limit (dBm/MHz)
5260	-1.59	-2.62	-1.65	2.84	6.11
5280	-0.69	-2.89	-1.88	3.04	6.11
5320	-3.22	-3.36	-1.83	2.03	6.11
5500	-1.81	-1.35	-0.90	3.43	6.11
5580	-1.93	-1.89	-0.27	3.48	6.11
5720	-0.26	-1.41	0.12	4.30	6.11

802.11n HT40 Mode

Frequency MHz	Chain 1 RF Power Density Reading (dBm/MHz)	Chain 2 RF Power Density Reading (dBm/MHz)	Chain 3 RF Power Density Reading (dBm/MHz)	RF Power Density Reading (dBm/MHz)	Maximum Limit (dBm/MHz)
5270	-6.31	-6.52	-5.50	-1.32	6.11
5310	-5.19	-7.20	-5.33	-1.04	6.11
5510	-4.77	-4.81	-4.71	0.01	6.11
5550	-4.42	-4.52	-4.20	0.40	6.11
5710	-3.82	-5.17	-2.97	0.88	6.11

802.11AC HT80 Mode

Frequency MHz	Chain 1 RF Power Density Reading (dBm/MHz)	Chain 2 RF Power Density Reading (dBm/MHz)	Chain 3 RF Power Density Reading (dBm/MHz)	RF Power Density Reading (dBm/MHz)	Maximum Limit (dBm/MHz)
5290	-8.17	-10.31	-9.05	-4.32	6.11
5530	-8.11	-8.44	-7.57	-3.25	6.11
5690	-7.60	-8.95	-6.91	-2.97	6.11

Note: 1. offset 0.5 dB for cable loss.

2. 5GHz antenna gain is 6.12dBi, Beamforming gain:4.77dBi , the limit is reduced 4.89 dB.

5250-5350 MHz

802.11a

Peak Power Spectral Density Data Plot (5260MHz)

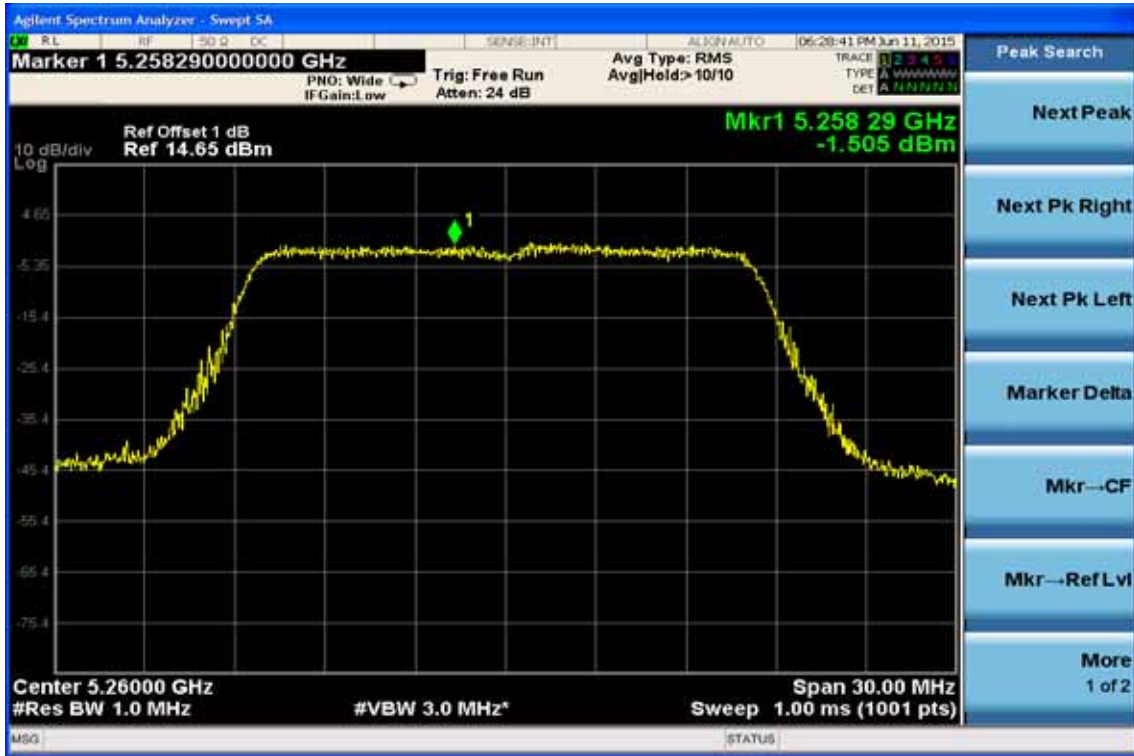

Peak Power Spectral Density Data Plot (5280MHz)



Peak Power Spectral Density Data Plot (5320MHz)



802.11n HT20 (chain 1)

Power Spectral Density Test Plot (5260MHz)



Power Spectral Density Test Plot (5280MHz)



Power Spectral Density Test Plot (5320MHz)



802.11n HT20 (chain 2) Power Spectral Density Test Plot (5260MHz)

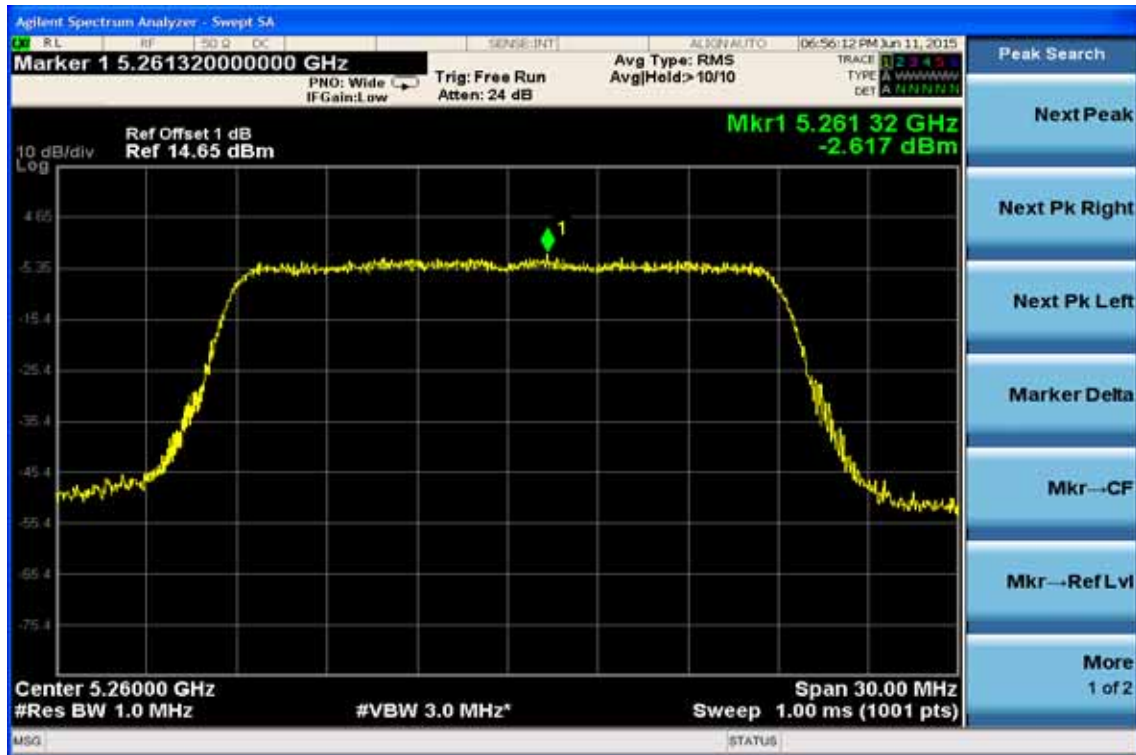

Power Spectral Density Test Plot (5280MHz)



Power Spectral Density Test Plot (5320MHz)

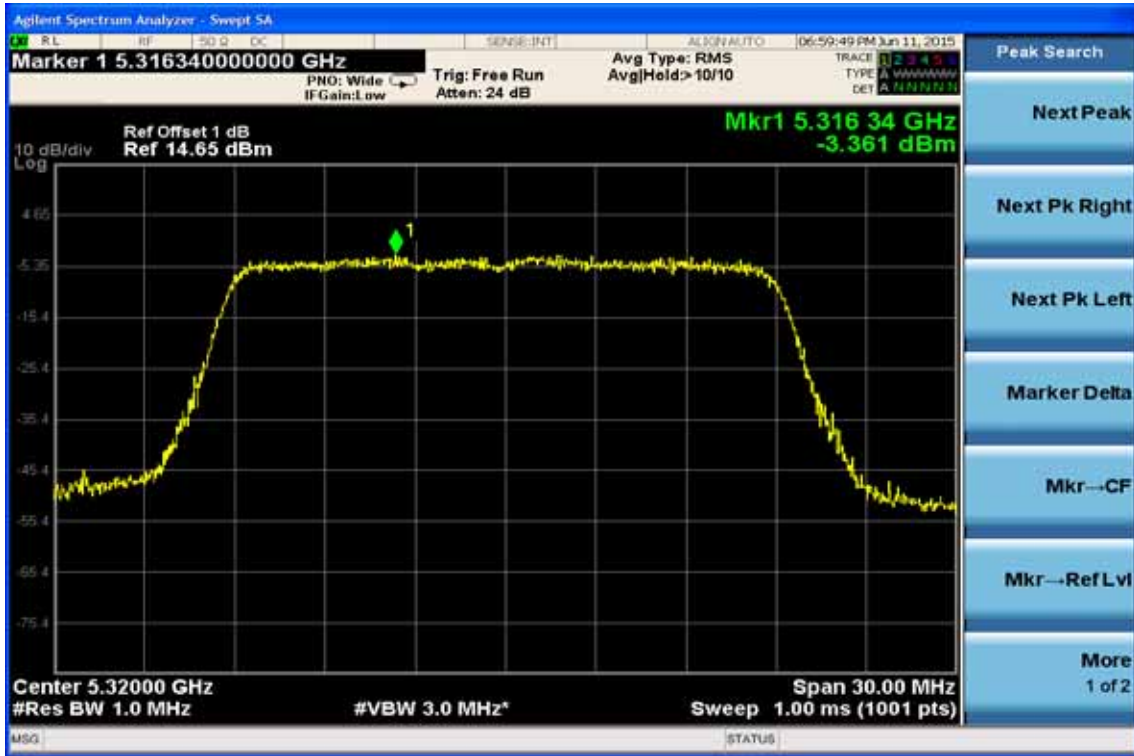

802.11n HT20 (chain 3)

Power Spectral Density Test Plot (5260MHz)



Power Spectral Density Test Plot (5280MHz)



Power Spectral Density Test Plot (5320MHz)



802.11n HT40 (chain 1) Power Spectral Density Test Plot (5270MHz)



Power Spectral Density Test Plot (5310MHz)



802.11n HT40 (chain 2) Power Spectral Density Test Plot (5270MHz)



Power Spectral Density Test Plot (5310MHz)



802.11n HT40 (chain 3) Power Spectral Density Test Plot (5270MHz)



Power Spectral Density Test Plot (5310MHz)



802.11AC HT80 (chain 1)
Power Spectral Density Test Plot (5290MHz)



802.11AC HT80 (chain 2)
Power Spectral Density Test Plot (5290MHz)



802.11AC HT80 (chain 3) Power Spectral Density Test Plot (5290MHz)

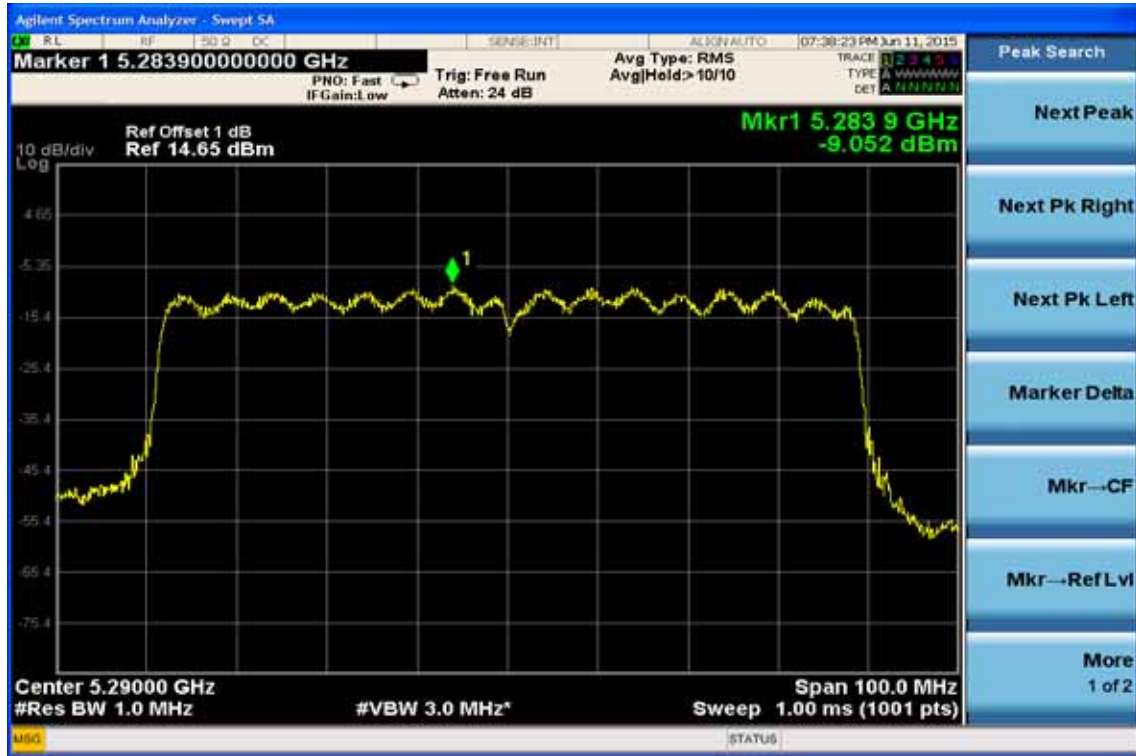

5470-5725 MHz

802.11a

Peak Power Spectral Density Data Plot (5500MHz)



Peak Power Spectral Density Data Plot (5580MHz)

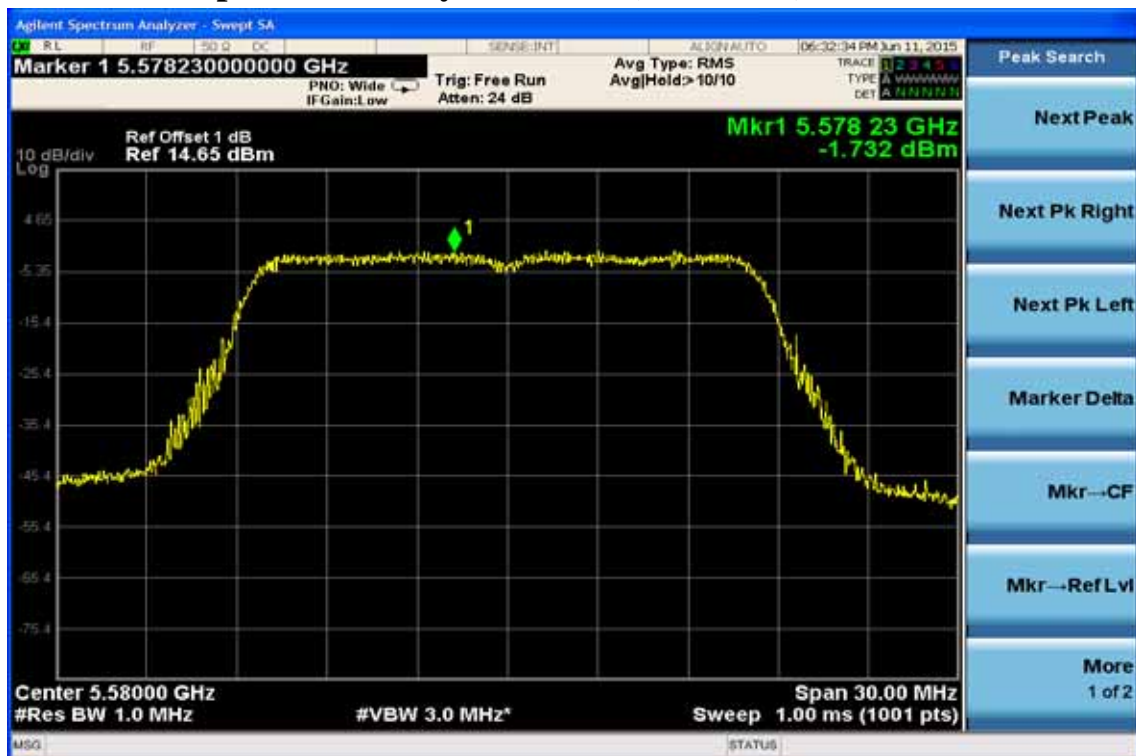

802.11a

Peak Power Spectral Density Data Plot (5720MHz)



802.11n HT20 (chain 1)

Power Spectral Density Test Plot (5500MHz)



Power Spectral Density Test Plot (5580MHz)



802.11n HT20

Power Spectral Density Test Plot (5720MHz)



802.11n HT20 (chain 2)
Power Spectral Density Test Plot (5500MHz)



Power Spectral Density Test Plot (5580 MHz)



Power Spectral Density Test Plot (5720MHz)



802.11n HT20 (chain 3)

Power Spectral Density Test Plot (5500MHz)



Power Spectral Density Test Plot (5580MHz)



Power Spectral Density Test Plot (5720MHz)



802.11n HT40 (chain 1) Power Spectral Density Test Plot (5510MHz)



Power Spectral Density Test Plot (5550MHz)

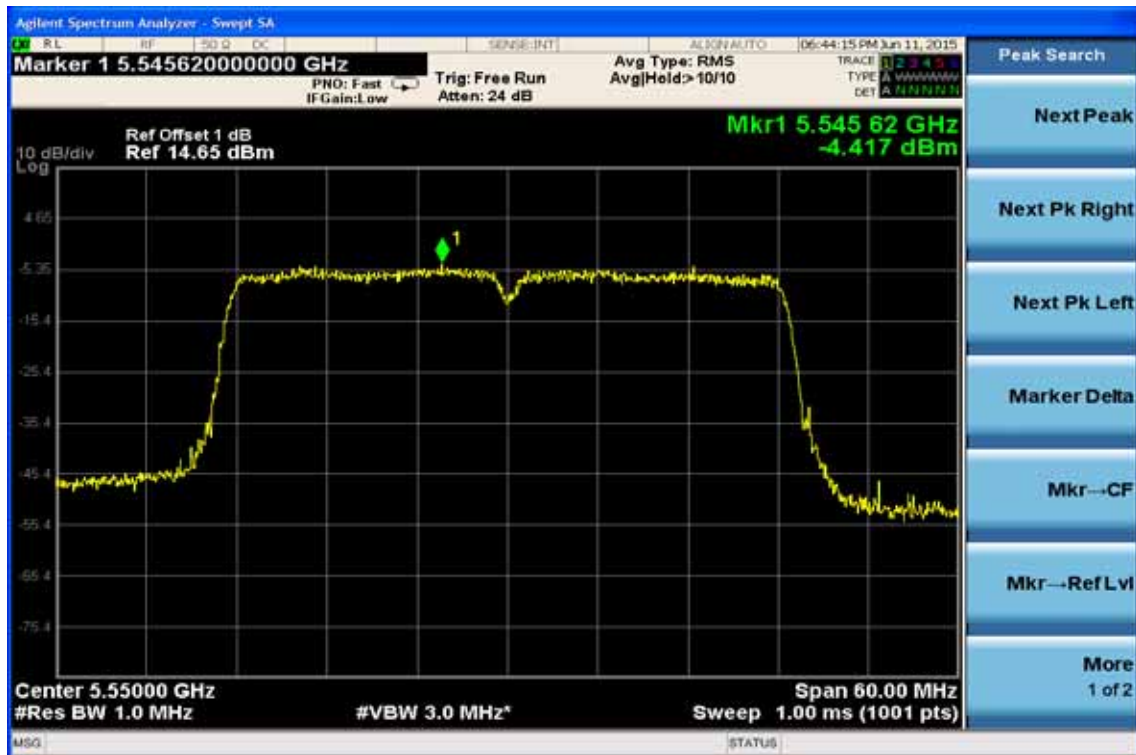

802.11n HT40 Power Spectral Density Test Plot (5710MHz)



802.11n HT40 (chain 2) Power Spectral Density Test Plot (5510MHz)

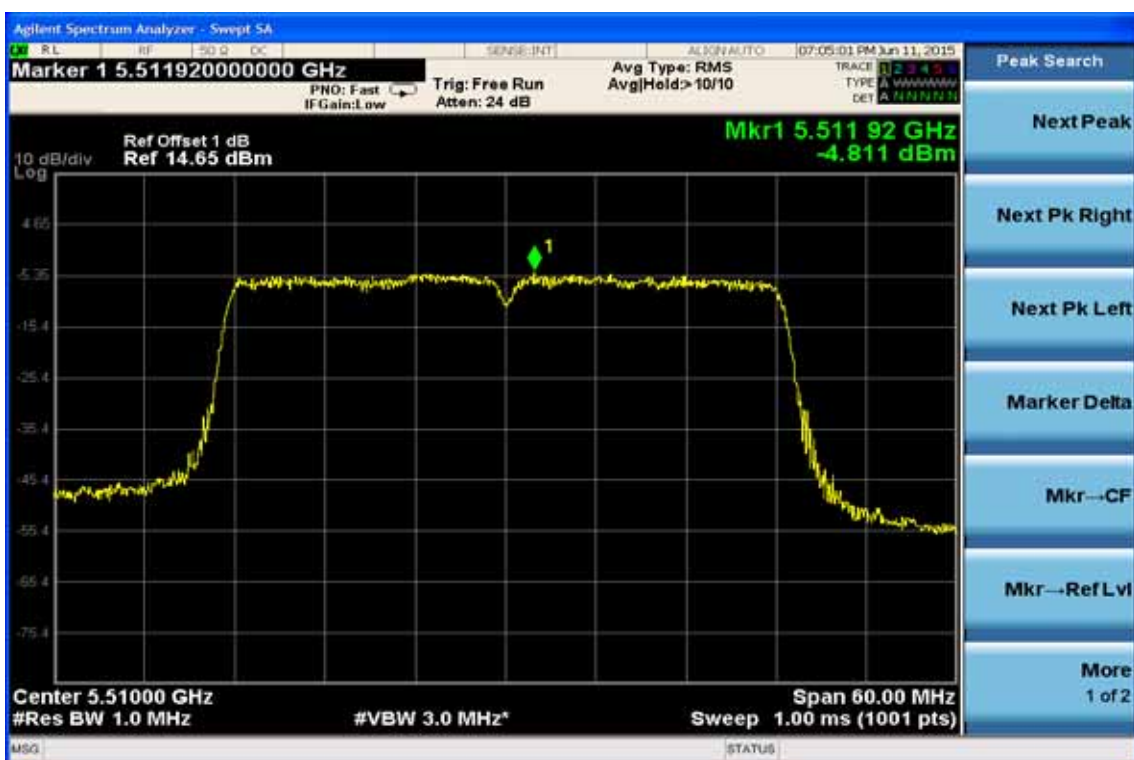

Power Spectral Density Test Plot (5550MHz)



802.11n HT40

Power Spectral Density Test Plot (5710MHz)

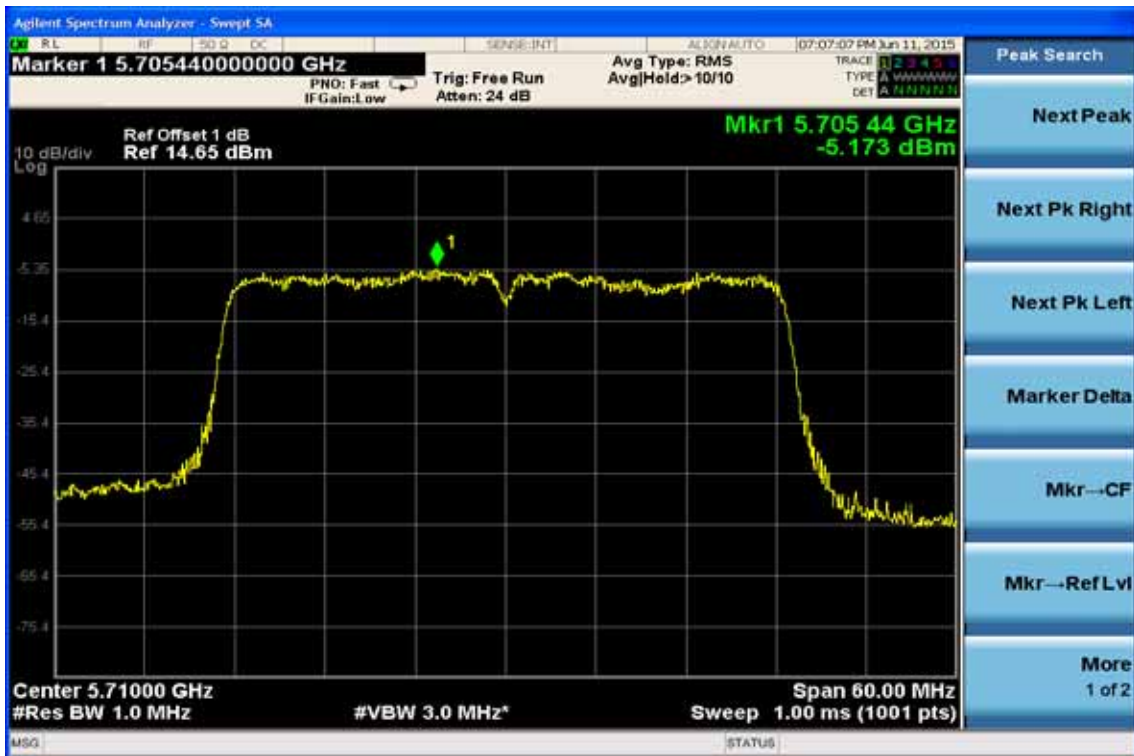

802.11n HT40 (chain 3)
Power Spectral Density Test Plot (5510MHz)



Power Spectral Density Test Plot (5550MHz)



802.11n HT40 Power Spectral Density Test Plot (5710MHz)



802.11AC HT80 (chain 1) Power Spectral Density Test Plot (5530MHz)



802.11AC HT80 Power Spectral Density Test Plot (5690MHz)



802.11AC HT80 (chain 2) Power Spectral Density Test Plot (5530MHz)



802.11AC HT80 Power Spectral Density Test Plot (5690MHz)

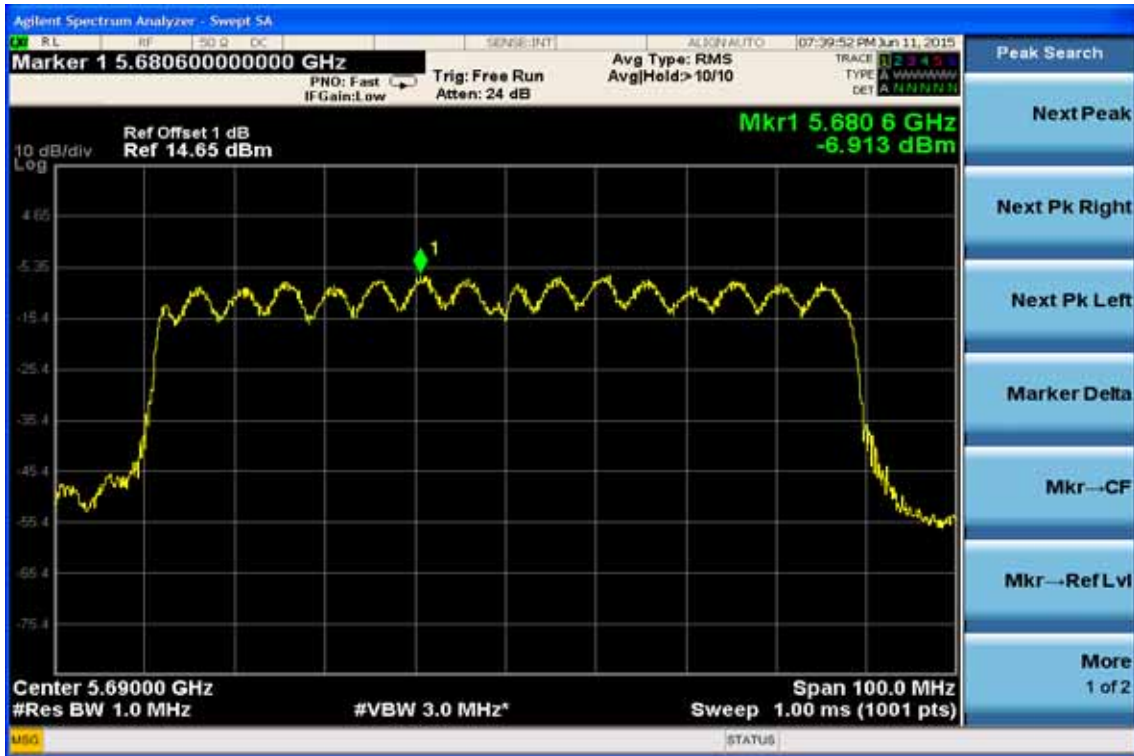

6. 26dB /99% EMISSION BANDWIDTH MEASUREMENT

6.1 Standard Applicable

According to §15.407(a). No Limit required.

6.2 Measurement Procedure

1. Place the EUT on the table and set it in transmitting mode.
2. Remove the antenna from the EUT and then connect a low loss RF cable from the antenna port to the spectrum analyzer.
3. Set the spectrum analyzer as RBW=300KHz/1MHz, VBW =1MHz/3MHz, Span=30/50/90MHz,, Sweep=auto
4. Mark the peak frequency and -26dB (upper and lower) frequency.
5. Repeat above procedures until all frequency measured were complete.

Refer to section D of KDB Document: KDB 789033 D02 General UNII Test Procedures New Rules v01

6.3 Measurement Equipment Used:

Refer to section 6.3 for details.

6.4 Test Set-up:

Refer to section 6.4 for details.

6.5 Measurement Result

5250-5350 MHz / 5470-5725 MHz

802.11a Mode

Frequency (MHz)	26dB Bandwidth (MHz)	99% Bandwidth (MHz)
5260	20.100	16.806
5280	20.240	16.823
5320	20.220	16.860
5500	20.300	16.830
5580	20.540	16.836
5720(within 5470-5725)	15.230	13.477

802.11n HT20 Mode

Frequency (MHz)	26dB Bandwidth (MHz)	99% Bandwidth (MHz)
5260	20.040	17.555
5280	20.120	17.638
5320	19.980	17.630
5500	20.080	17.586
5580	20.070	17.608
5720(within 5470-5725)	15.130	13.876

802.11n HT40 Mode

Frequency (MHz)	26dB Bandwidth (MHz)	99% Bandwidth (MHz)
5270	40.230	37.029
5310	40.280	36.996
5510	39.820	36.940
5550	40.190	37.018
5710(within 5470-5725)	35.130	33.291

802.11a HT80 Mode

Frequency (MHz)	26dB Bandwidth (MHz)	99% Bandwidth (MHz)
5290	81.610	76.504
5530	80.910	76.230
5690(within 5470-5725)	75.730	72.605

5470-5725 MHz (Outside Bandwidth)

802.11a Mode

Frequency (MHz)	26dB Bandwidth (MHz)	99% Bandwidth (MHz)
5720	5.200	4.173

802.11n HT20 Mode

Frequency (MHz)	26dB Bandwidth (MHz)	99% Bandwidth (MHz)
5720	5.212	4.258

802.11n HT40 Mode

Frequency (MHz)	26dB Bandwidth (MHz)	99% Bandwidth (MHz)
5710	5.360	4.338

802.11a HT80 Mode

Frequency (MHz)	26dB Bandwidth (MHz)	99% Bandwidth (MHz)
5690	6.602	4.801

5250MHz – 5350MHz

802.11a

26dB & 99% Band Width Test Data (5260MHz)

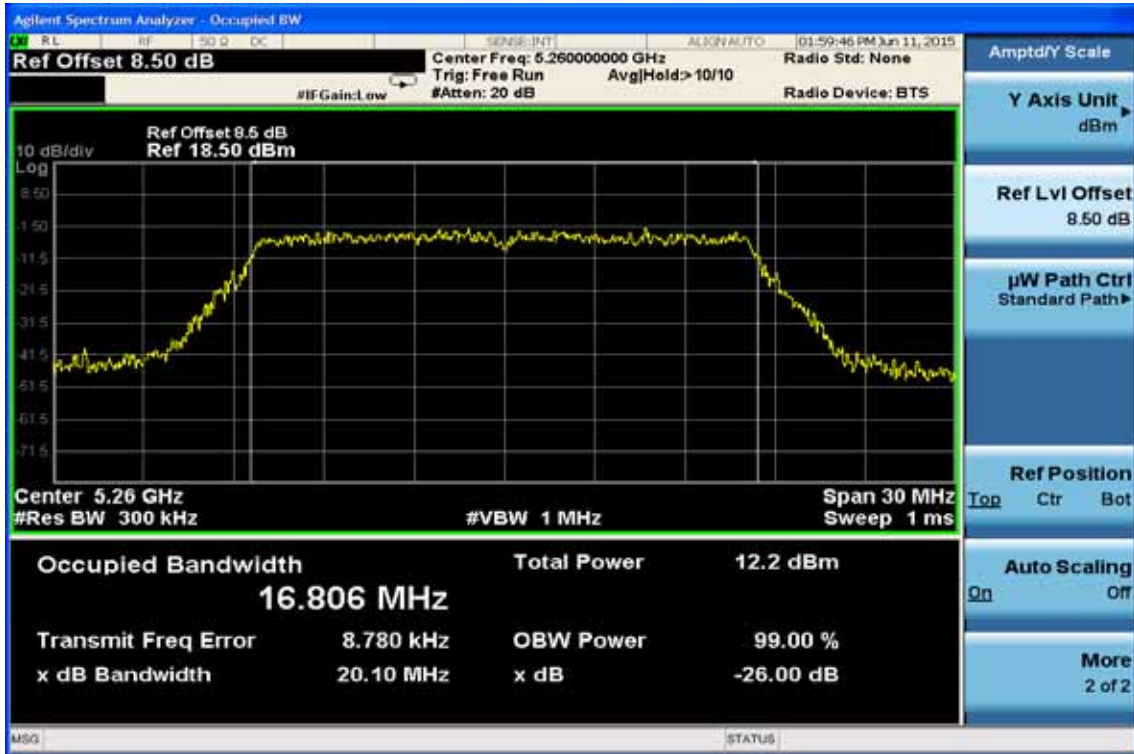

26dB & 99% Band Width Test Data(5280MHz)

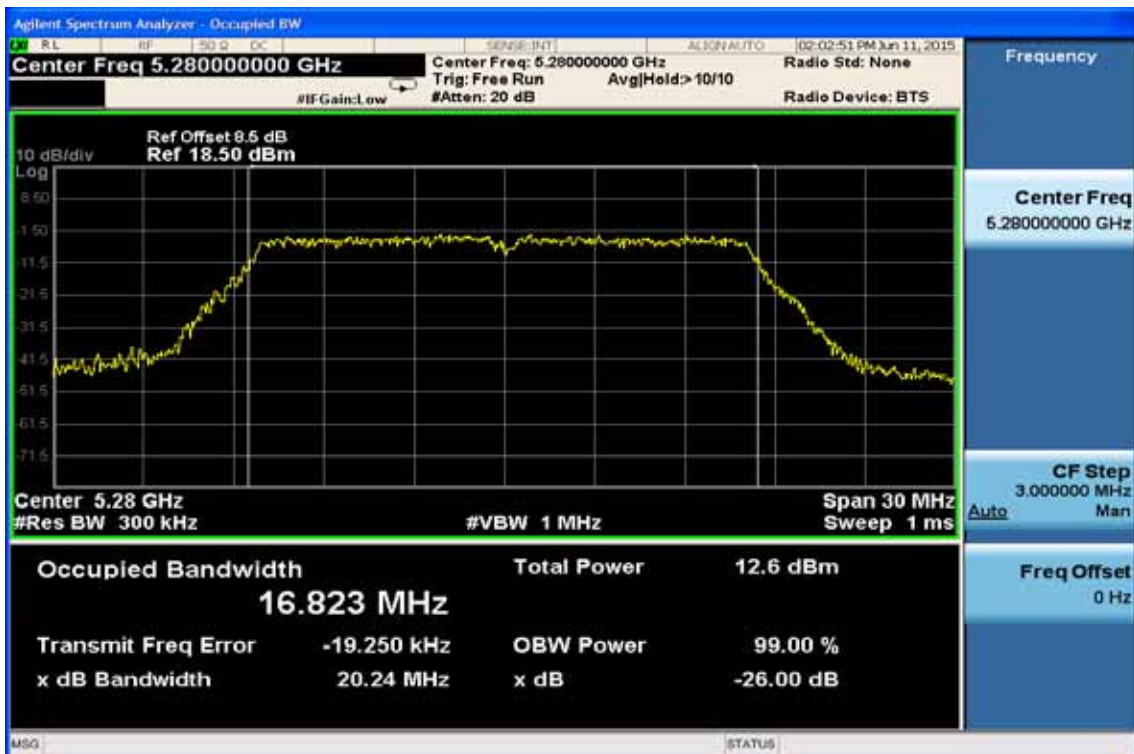

26dB & 99% Band Width Test Data (5320MHz)

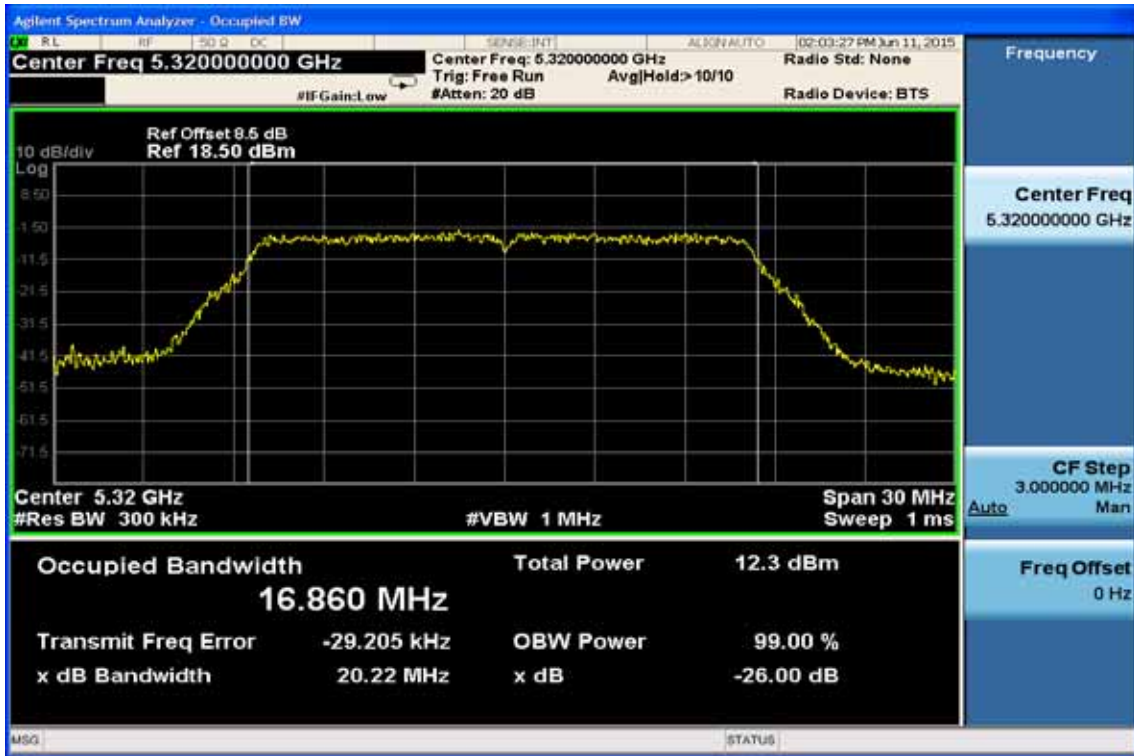

802.11n HT20

26dB & 99% Band Width Test Data (5260MHz)



26dB &99% Band Width Test Data(5280MHz)



26dB &99% Band Width Test Data (5320MHz)

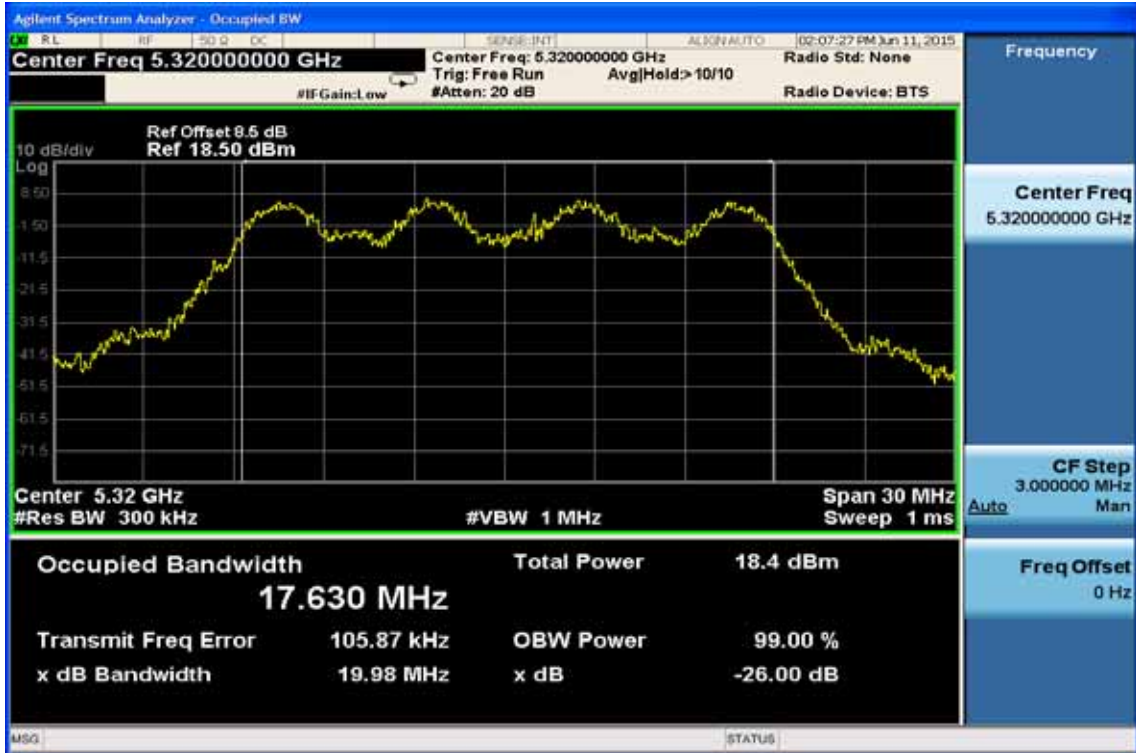

**802.11n HT40
26dB &99% Band Width Test Data (5270MHz)**

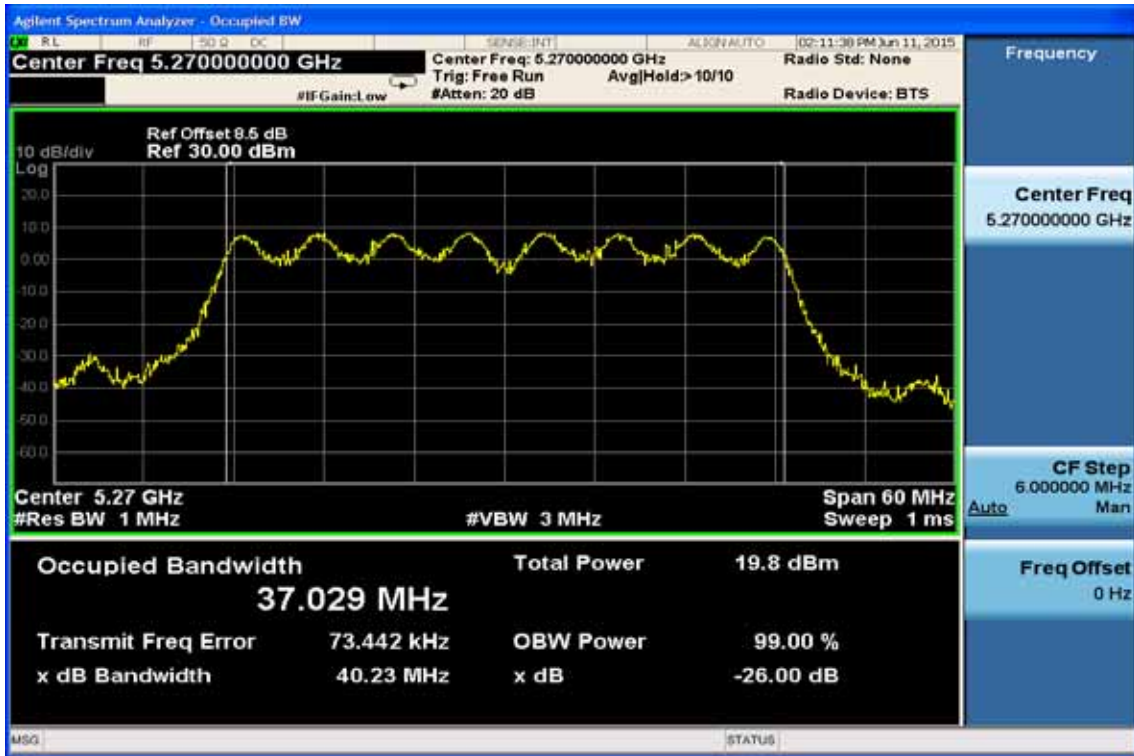

26dB &99%Band Width Test Data (5310MHz)

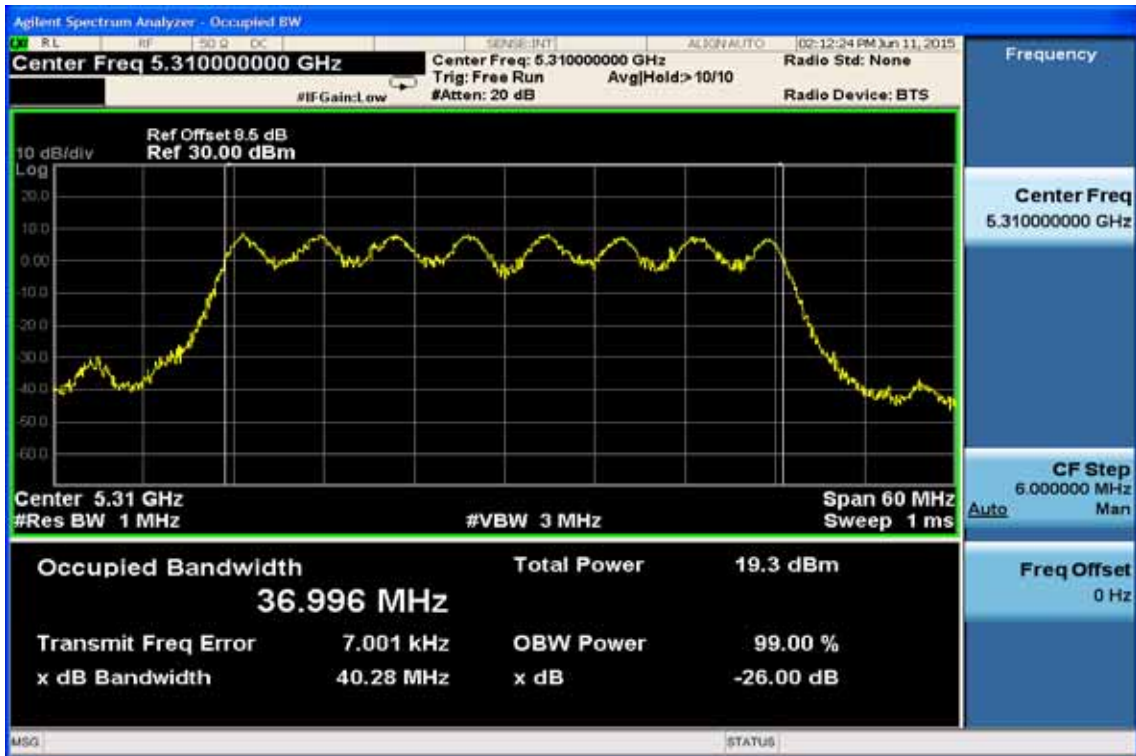

802.11AC HT80
26dB & 99% Band Width Test Data (5290MHz)

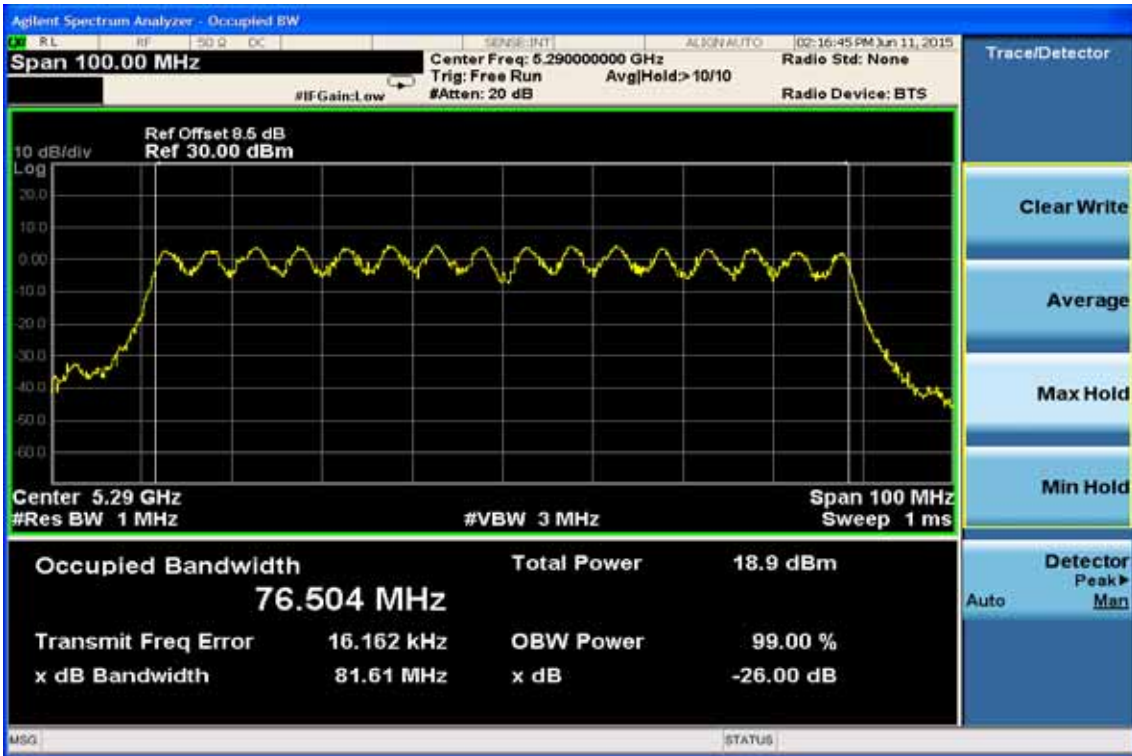

5470-5725 MHz

802.11a

26dB &99% Band Width Test Data (5500MHz)

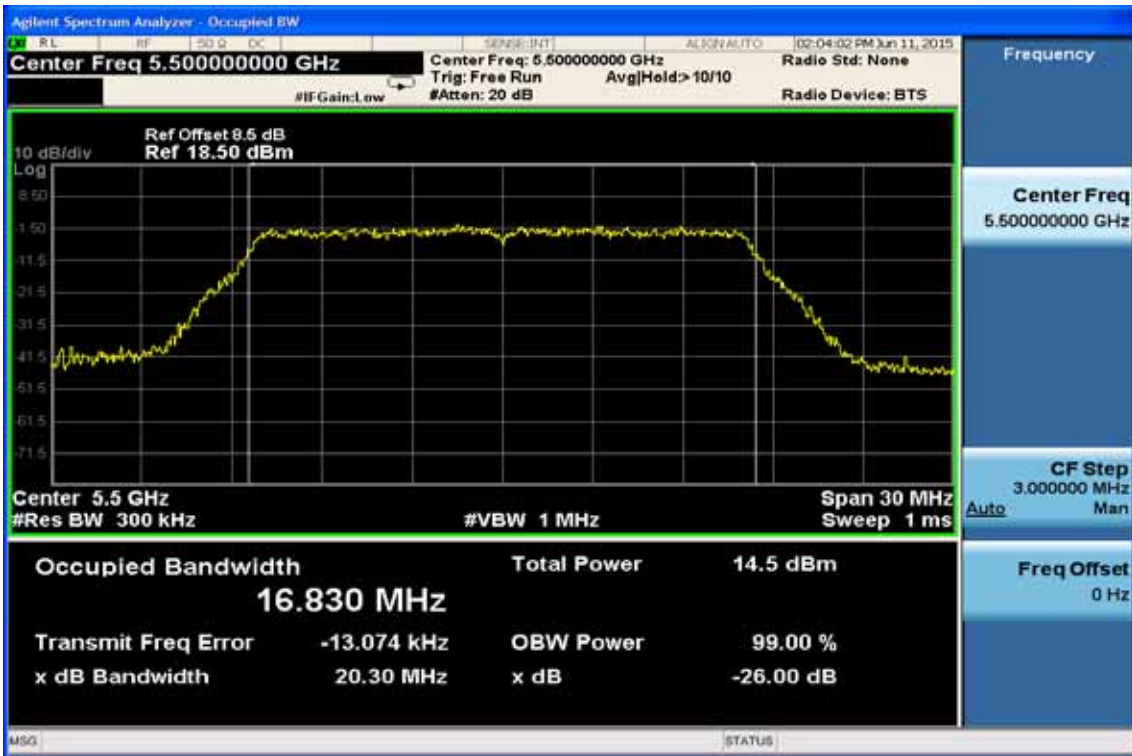

26dB &99% Band Width Test Data (5580MHz)

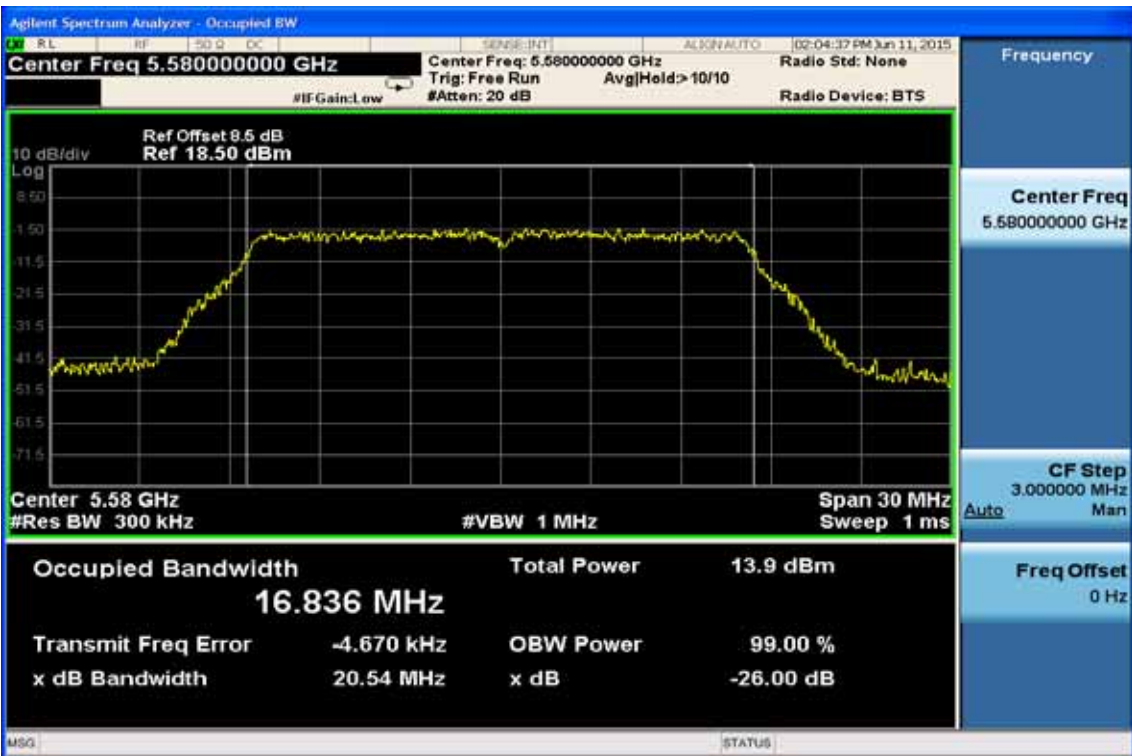

802.11a

26dB & 99% Band Width Test Data (5720MHz) -1 (within 5470-5725)

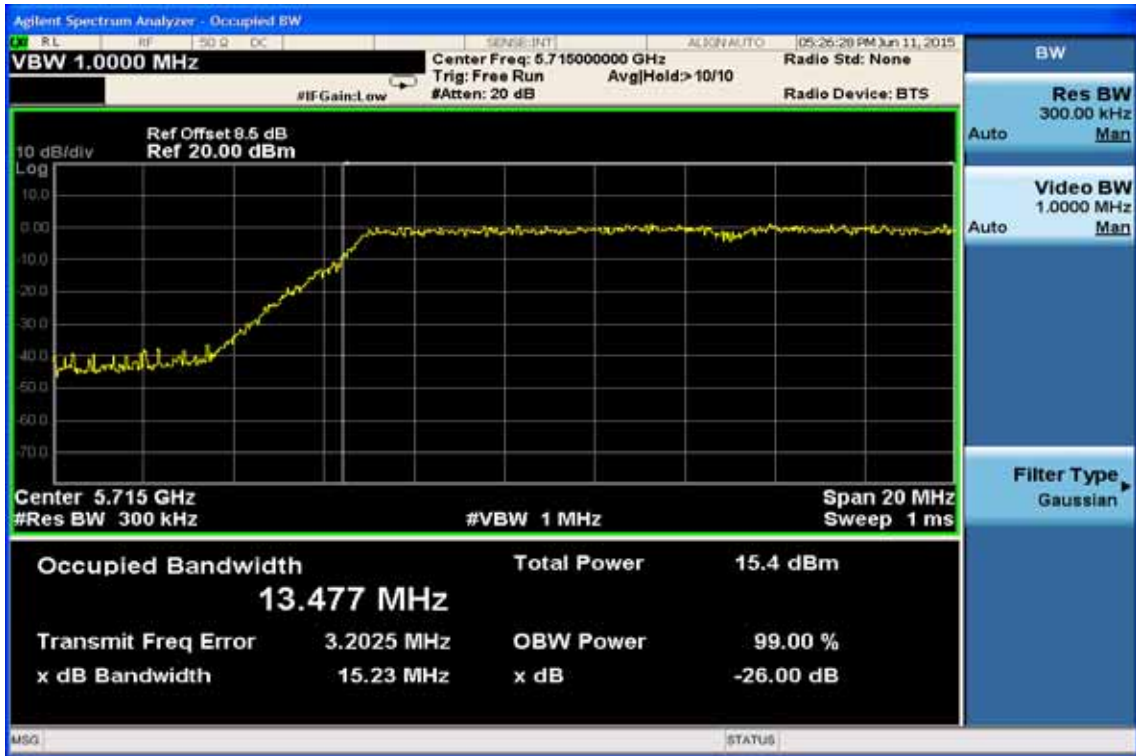

26dB & 99% Band Width Test Data (5720MHz) -2 (Out side)

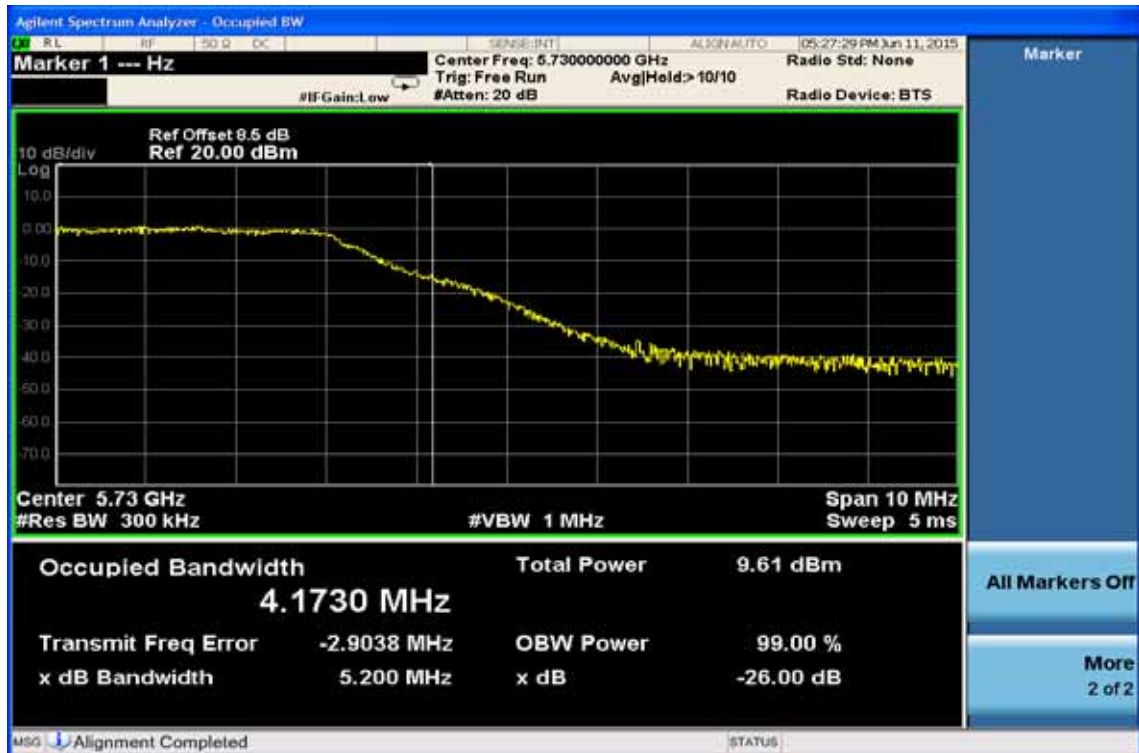

**802.11n HT20
26dB &99% Band Width Test Data (5500MHz)**

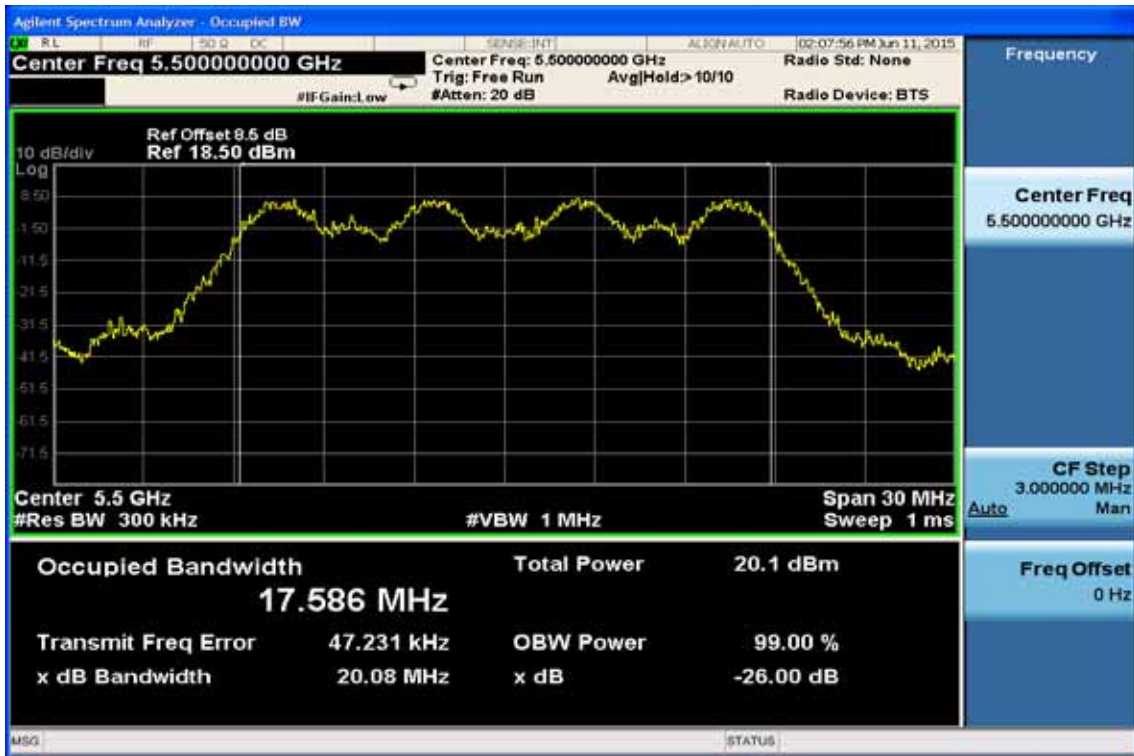

26dB &99% Band Width Test Data (5580MHz)



802.11n HT20

26dB & 99% Band Width Test Data (5720MHz) -1 (within 5470-5725)

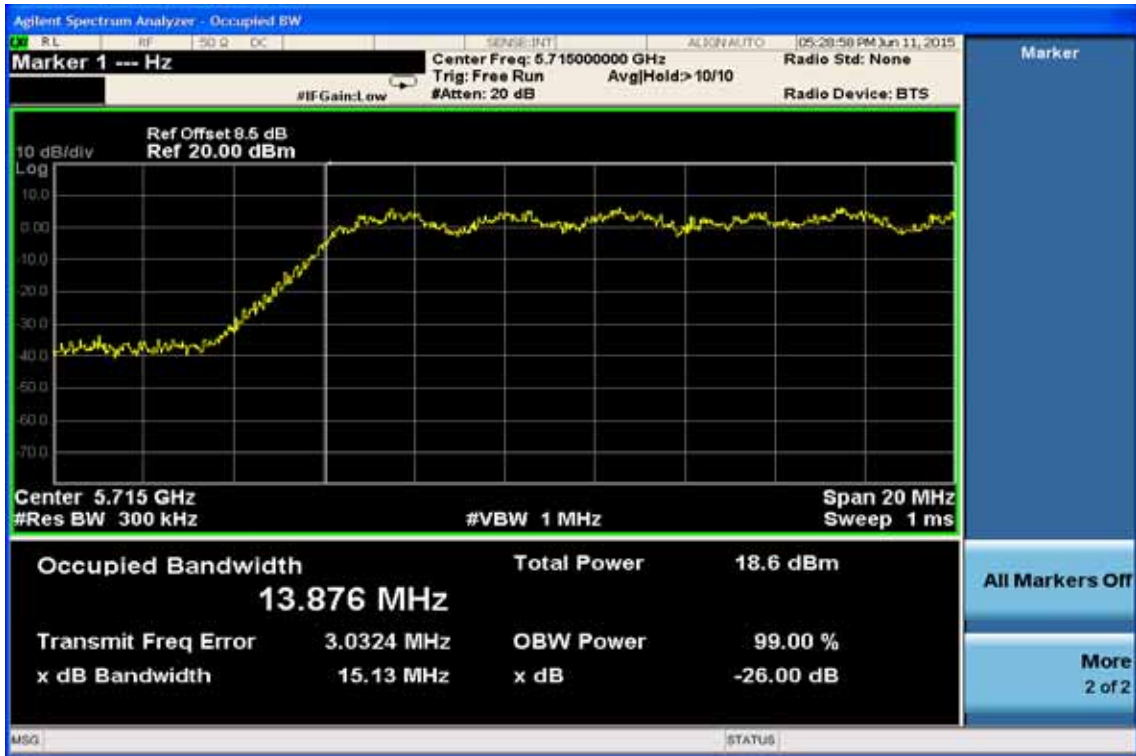

26dB & 99% Band Width Test Data (5720MHz) -2 (Out side)

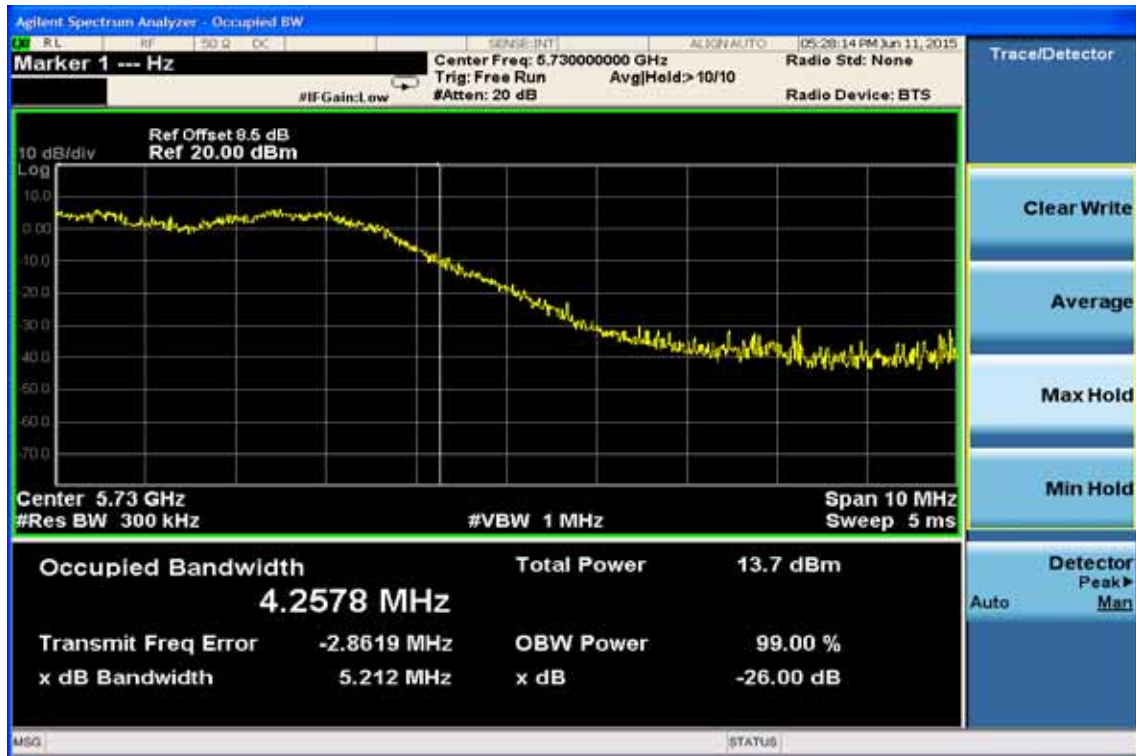

802.11n HT40
26dB &99% Band Width Test Data (5510MHz)

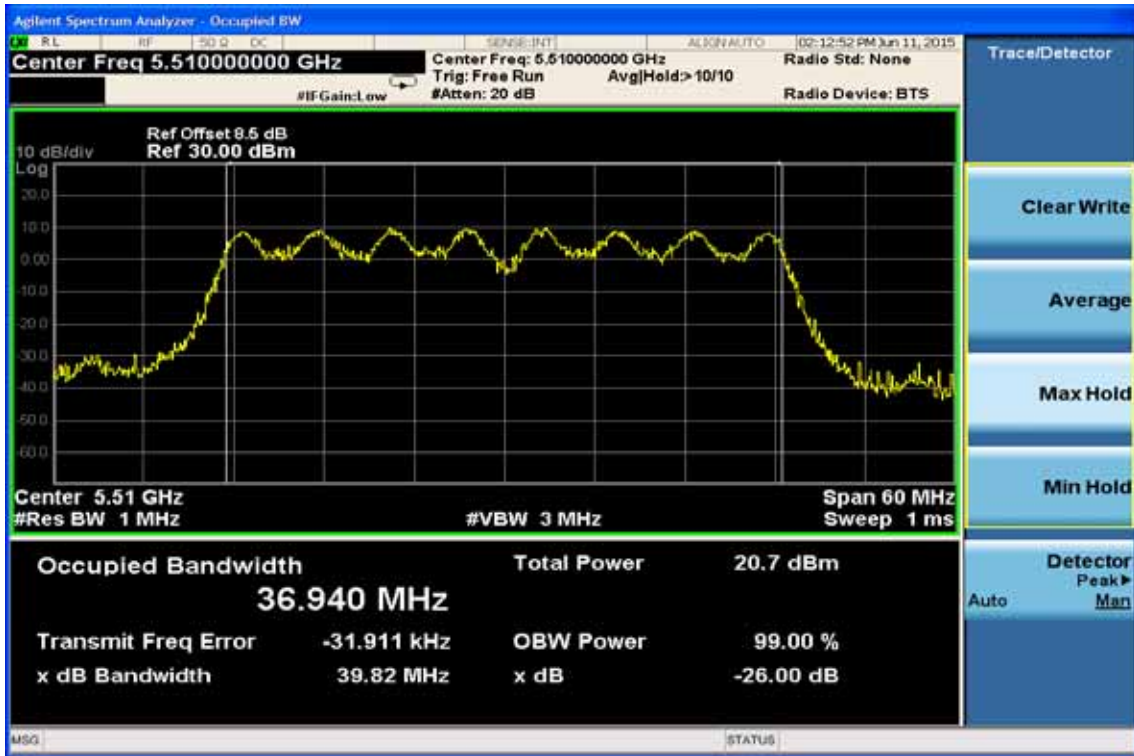

26dB &99% Band Width Test Data (5550MHz)

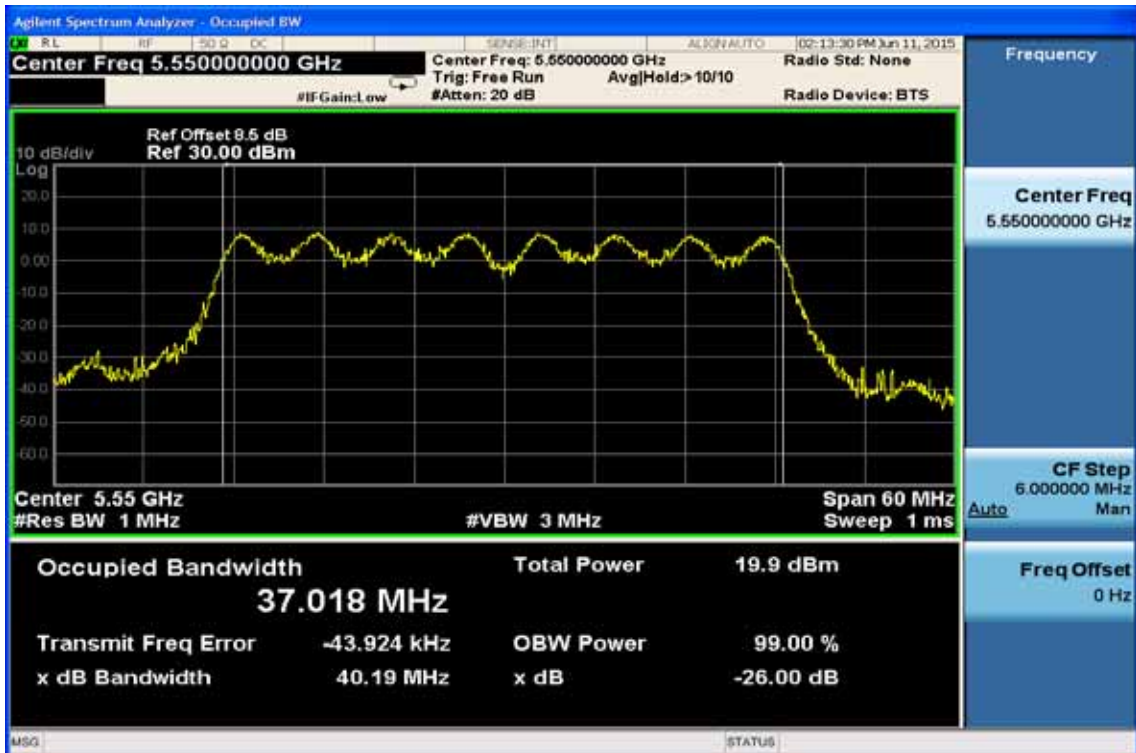

802.11n HT40

26dB & 99% Band Width Test Data (5710MHz) -1 (within 5470-5725)

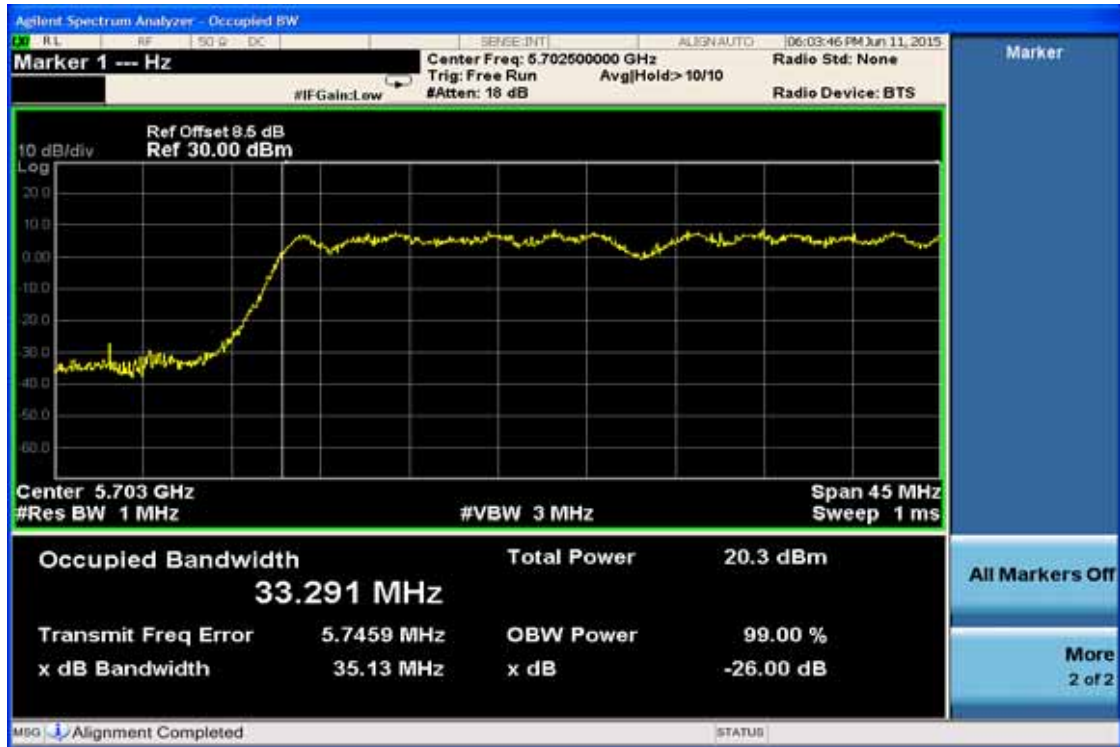

26dB & 99% Band Width Test Data (5710MHz) -2 (Out side)

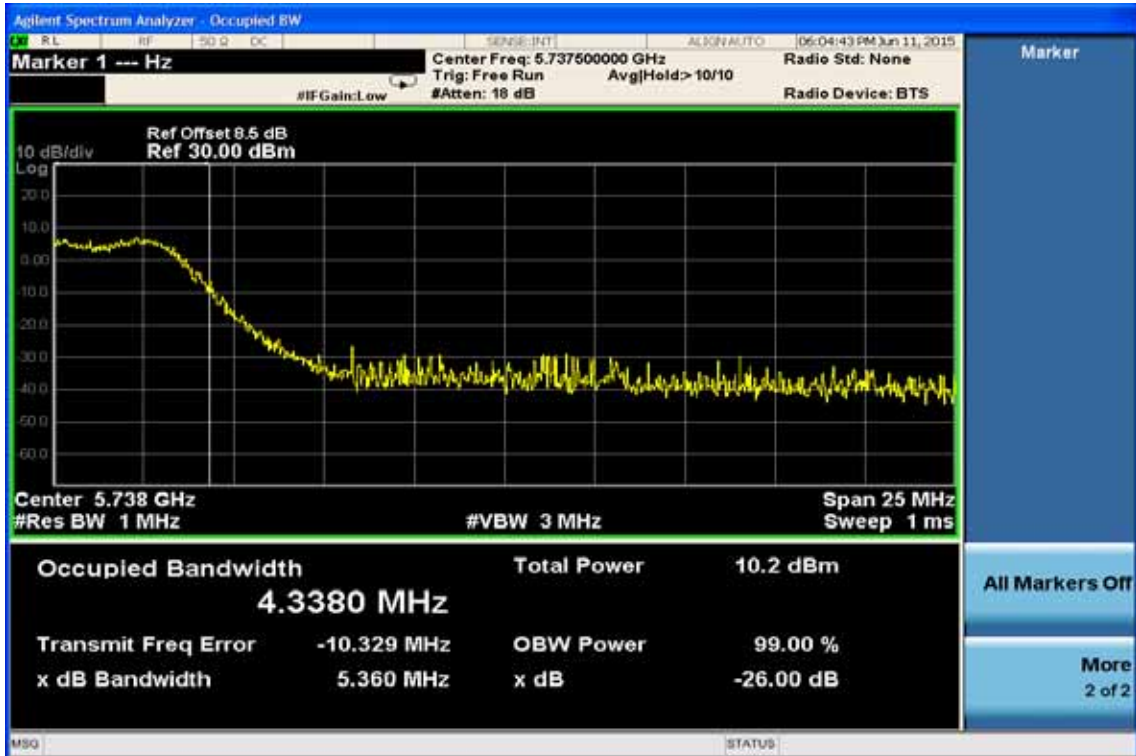

**802.11AC HT80
26dB &99% Band Width Test Data (5530MHz)**

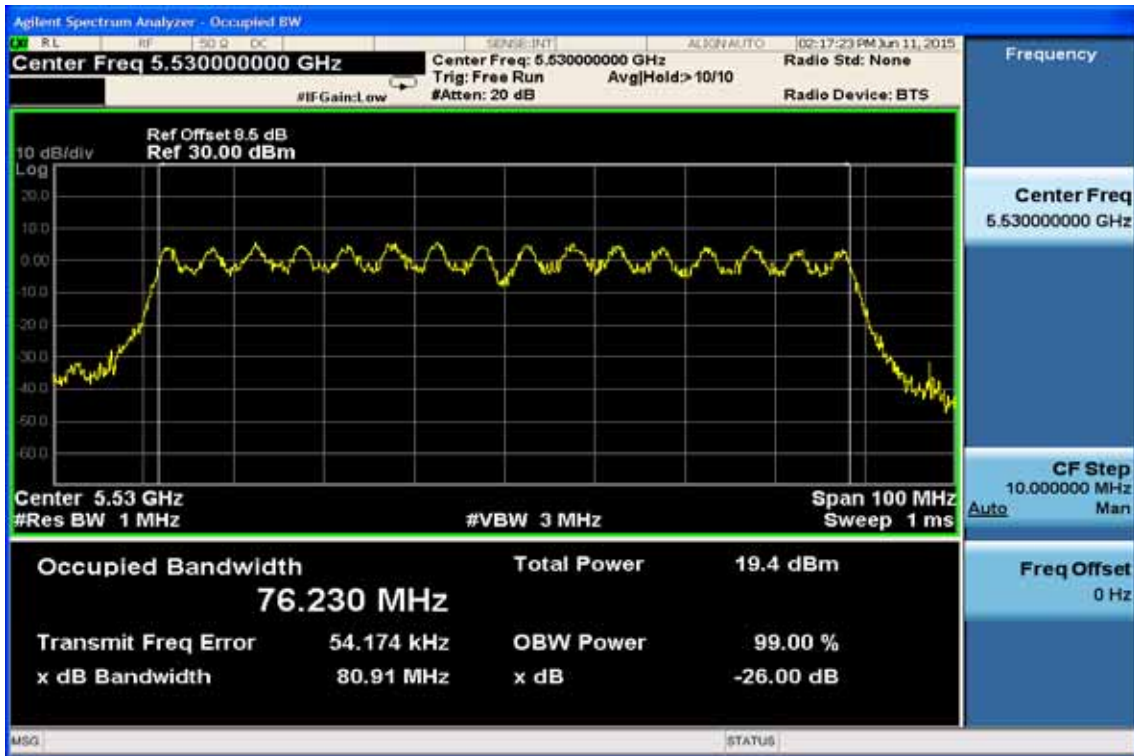

**802.11AC HT80
26dB &99% Band Width Test Data (5690MHz)-1 (within 5470-5725)**

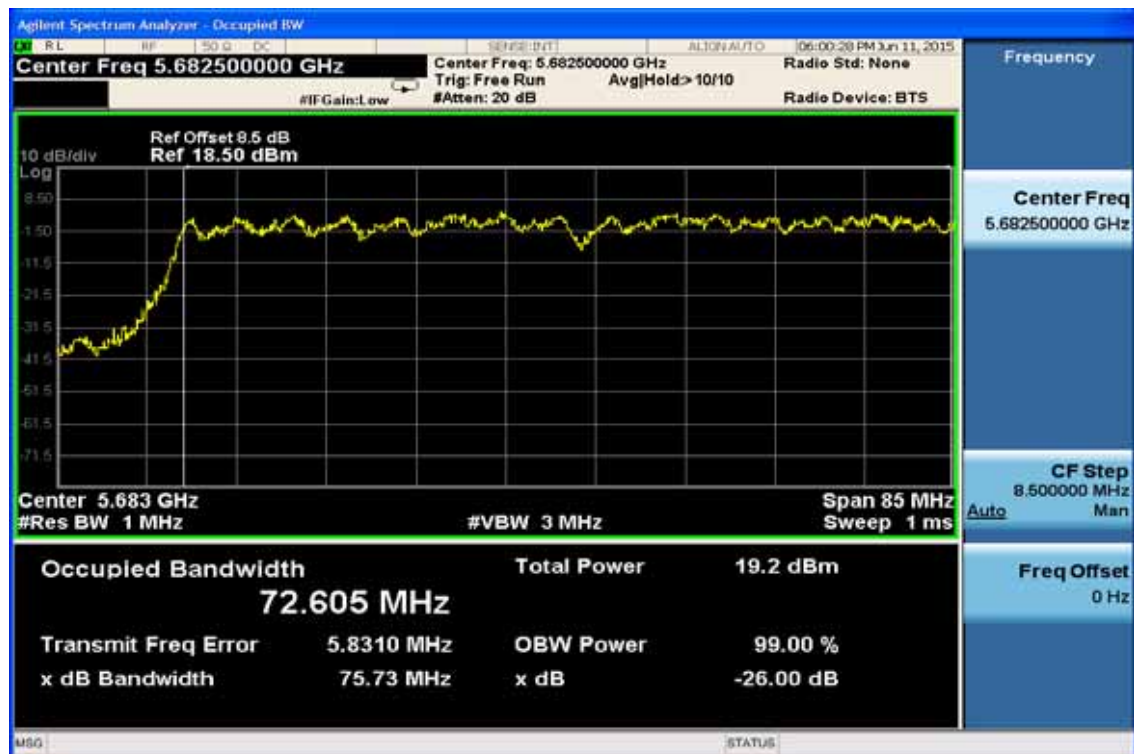

802.11AC HT80
26dB & 99% Band Width Test Data (5690MHz)-2 (Out side)

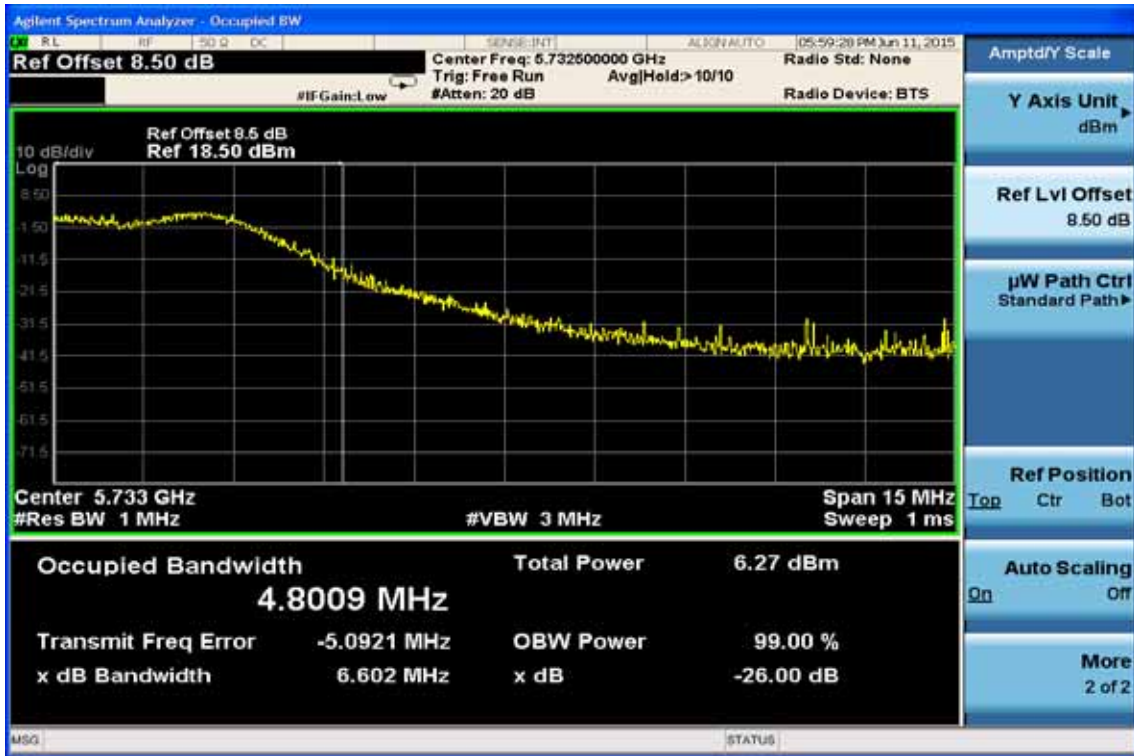

7. UNDESIRABLE EMISSION - RADICTED MEASUREMENT

7.1 Standard Applicable

According to §15.407(b),

According to §15.407(b), Undesirable Emission Limits: Except as shown in Paragraph (b)(7) of this section, the peak emissions outside of the frequency bands of operation shall be attenuated in accordance with the following limits:

- (1) For transmitters operating in the 5.15-5.25 GHz band: all emissions outside of the 5.15-5.35 GHz band shall not exceed an e.i.r.p. of -27 dBm/MHz.
- (2) For transmitters operating in the 5.25-5.35 GHz band: all emissions outside of the 5.15-5.35 GHz band shall not exceed an e.i.r.p. of -27 dBm/MHz.
- (3) For transmitters operating in the 5.47-5.725 GHz band: all emissions outside of the 5.47-5.725 GHz band shall not exceed an e.i.r.p. of -27 dBm/MHz.
- (4) For transmitters operating in the 5.725-5.85 GHz band: all emissions within the frequency range from the band edge to 10 MHz above or below the band edge shall not exceed an e.i.r.p. of -17dBm/MHz; for frequencies 10 MHz or greater above or below the band edge, emissions shall not exceed an e.i.r.p. of -27 dBm/MHz.
- (5) The above emission measurements shall be performed using a minimum resolution bandwidth of 1 MHz. A lower resolution bandwidth may be employed near the band edge, when necessary, provided the measured energy is integrated to show the total power over 1 MHz.
- (6) Unwanted emissions below 1 GHz must comply with the general field strength limits set forth in Section 15.209. Further, any U-NII devices using an AC power line are required to comply also with the conducted limits set forth in Section 15.207.
- (7) The provisions of Section 15.205 of this part apply to intentional radiators operating under this section.
- (8) When measuring the emission limits, the nominal carrier frequency shall be adjusted as close to the upper and lower frequency band edges as the design of the equipment permits.

§15.205- RESTRICTED BANDS OF OPERATIONS

(a) Except as shown in paragraph (d) of this section, only spurious emissions are permitted in any of the frequency bands listed below:

MHz	MHz	MHz	GHz
0.090 - 0.110	16.42 - 16.423	399.9 - 410	4.5 - 5.15
¹ 0.495 - 0.505	16.69475 - 16.69525	608 - 614	5.35 - 5.46
2.1735 - 2.1905	16.80425 - 16.80475	960 - 1240	7.25 - 7.75
4.125 - 4.128	25.5 - 25.67	1300 - 1427	8.025 - 8.5
4.17725 - 4.17775	37.5 - 38.25	1435 - 1626.5	9.0 - 9.2
4.20725 - 4.20775	73 - 74.6	1645.5 - 1646.5	9.3 - 9.5
6.215 - 6.218	74.8 - 75.2	1660 - 1710	10.6 - 12.7
6.26775 - 6.26825	108 - 121.94	1718.8 - 1722.2	13.25 - 13.4
6.31175 - 6.31225	123 - 138	2200 - 2300	14.47 - 14.5
8.291 - 8.294	149.9 - 150.05	2310 - 2390	15.35 - 16.2
8.362 - 8.366	156.52475 -	2483.5 - 2500	17.7 - 21.4
8.37625 - 8.38675	156.52525	2655 - 2900	22.01 - 23.12
8.41425 - 8.41475	156.7 - 156.9	3260 - 3267	23.6 - 24.0
12.29 - 12.293	162.0125 - 167.17	3332 - 3339	31.2 - 31.8
12.51975 - 12.52025	167.72 - 173.2	3345.8 - 3358	36.43 - 36.5
12.57675 - 12.57725	240 - 285	3600 - 4400	(²)
13.36 - 13.41	322 - 335.4		

¹ Until February 1, 1999, this restricted band shall be 0.490-0.510 MHz.

² Above 38.6

(b) Except as provided in paragraphs (d) and (e), the field strength of emissions appearing within these frequency bands shall not exceed the limits shown in Section 15.209. At frequencies equal to or less than 1000 MHz, compliance with the limits in Section 15.209 shall be demonstrated using measurement instrumentation employing a CISPR quasi-peak detector. Above 1000 MHz, compliance with the emission limits in Section 15.209 shall be demonstrated based on the average value of the measured emissions. The provisions in Section 15.35 apply to these measurements.

§15.209- RADIATED EMISSION LIMITS: GENERAL REQUIREMENTS

FCC PART 15.209

MEASURING DISTANCE OF 3 METER		
FREQUENCY RANGE (MHz)	FIELD STRENGTH (Microvolts/m)	FIELD STRENGTH (dBuV/m)
30-88	100	40
88-216	150	43.5
216-960	200	46
Above 960	500	54

7.2 EUT Setup

1. The radiated emission tests were performed in the 3 meter open-test side, using the setup in accordance with the ANSI C63.10:2013.
2. The EUT was put in the front of the test table. The host PC system was placed on the center of the back edge on the test table. The peripherals like modem, monitor printer, K/B, and mouse were placed on the side of the host PC system. The rear of the EUT and peripherals were placed flushed with the rear of the tabletop.
3. The keyboard was placed directly in the front of the monitor, flushed with the front tabletop. The mouse was placed next to the Keyboard, flushed with the back of keyboard.
4. The spacing between the peripherals was 10 centimeters.
5. External I/O cables were draped along the edge of the test table and bundle when necessary.
6. The host PC system was connected with 120Vac/60Hz power source.

7.3 Measurement Procedure

1. The EUT was placed on a turn table which is 0.8/1.5m above ground plane.
2. The turn table shall rotate 360 degrees to determine the position of maximum emission level.
3. EUT is set 3m away from the receiving antenna which varied from 1m to 4m to find out the highest emissions.
4. Maximum procedure was performed on the six highest emissions to ensure EUT compliance.
5. And also, each emission was to be maximized by changing the polarization of receiving antenna both horizontal and vertical.
6. Repeat above procedures until all frequency measured were complete.

Refer to section G of KDB Document: KDB 789033 D02 General UNII Test Procedures New Rules v01

7.4 Test SET-UP (Block Diagram of Configuration)

(A) Radiated Emission Test Set-Up, Frequency Below 1000MHz

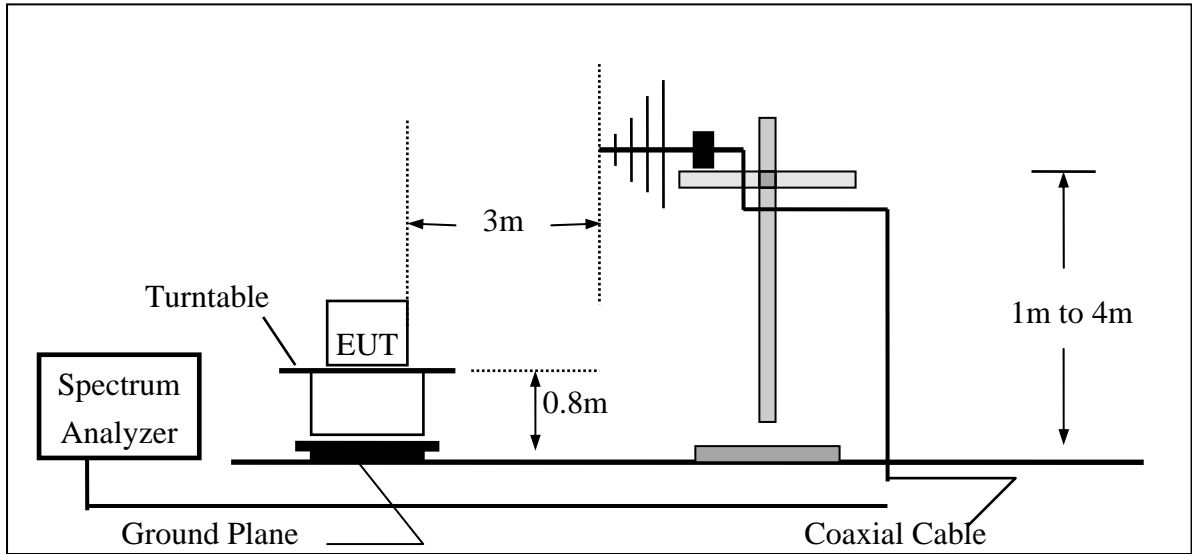

(B) Radiated Emission Test Set-UP Frequency Over 1 GHz

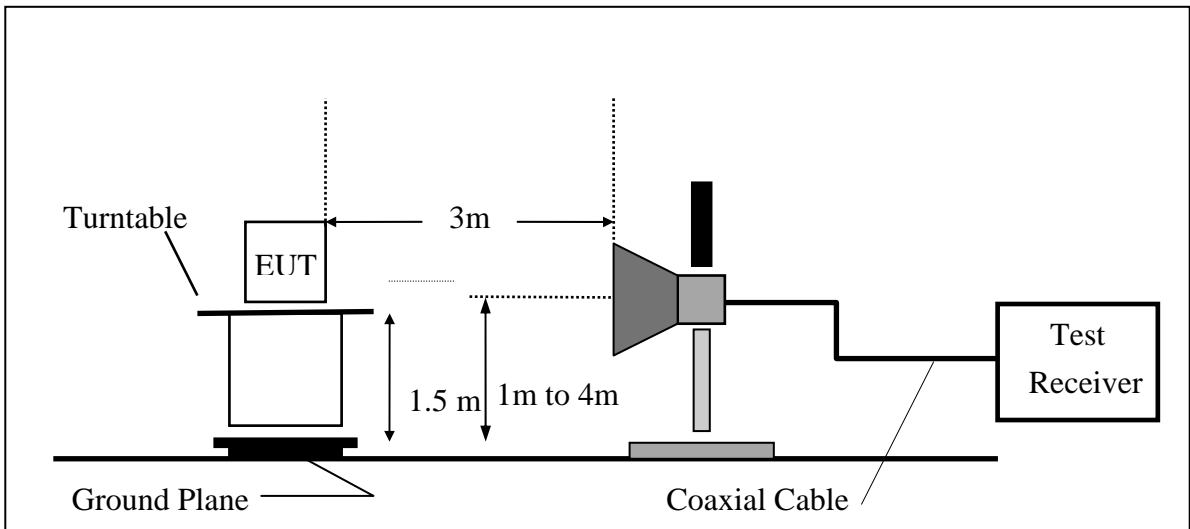

7.5 Measurement Equipment Used:

Chamber 14(966)					
EQUIPMENT TYPE	MFR	MODEL NUMBER	SERIAL NUMBER	LAST CAL.	CAL DUE.
Spectrum Analyzer 21(26.5GHz)	Agilent	N9010A	MY49060537	07/30/2015	07/29/2016
Spectrum Analyzer 20(6.5GHz)	Agilent	E4443A	MY48250315	05/21/2015	05/20/2016
Spectrum Analyzer 22(43GHz)	R&S	FSU43	100143	05/23/2015	05/22/2016
Dipole antenna	SCHWARZBECK	VHAP,30-300	919	12/03/2013	12/02/2015
Dipole antenna	SCHWARZBECK	UHAP,300-1000	1195	12/03/2013	12/02/2015
Loop Antenna9K-30M	A.H.SYSTEM	SAS-564	294	05/11/2015	05/10/2017
Bilog Antenna30-1G	Schaffner	CBL 6112B	2756	12/30/2014	12/29/2015
Horn antenna1-18G	ETS	3117	00066665	11/27/2014	11/26/2015
Horn antenna26-40G(05)	Com-power	AH-640	100A	01/21/2015	01/20/2017
Horn antenna18-26G(04)	Com-power	AH-826	081001	07/24/2015	07/23/2017
Preamplifier9-1000M	HP	8447D	NA	03/12/2015	03/11/2016
Preamplifier1-18G	MITEQ	AFS44-00101800-25-10P-44	1329256	07/28/2015	07/27/2016
Preamplifier1-26G	EM	EM01M26G	NA	03/11/2015	03/10/2016
Preamplifier26-40G	MITEQ	JS-26004000-27-5A	818471	07/23/2015	07/22/2017
Cable1-18G	HUBER SUHNER	Sucoflex 106	NA	12/02/2014	12/01/2015
Cable UP to 1G	HUBER SUHNER	RG 214/U	NA	10/17/2014	10/16/2015
SUCOFLEX 1GHz~40GHz cable	HUBER SUHNER	Sucoflex 102	27963/2&37421/2	10/03/2013	10/02/2015
Signal Generator	R&S	SMU200A	102330	03/11/2015	02/10/2016
Signal Generator	Anritsu	MG3692A	20311	10/29/2014	10/28/2015
2.4G Filter	Micro-Tronics	Brm50702	76	12/27/2014	12/26/2015
5G Filter	Micro-Tronics	Brm50716	005	12/27/2014	12/26/2015

7.6 Field Strength Calculation

The field strength is calculated by adding the Antenna Factor and Cable Factor and subtracting the Amplifier Gain and Duty Cycle Correction Factor(if any) from the measured reading. The basic equation with a sample calculation is as follows:

$$FS = RA + AF + CL - AG$$

Where	FS = Field Strength	CL = Cable Attenuation Factor (Cable Loss)
	RA = Reading Amplitude	AG = Amplifier Gain
	AF = Antenna Factor	

7.7 Measurement Result

Refer to attach tabular data sheets.

NOTE:

The resolution bandwidth and video bandwidth of test receiver/spectrum analyzer is 100kHz for Peak detection (PK) and Quasi-peak detection (QP) at frequency below 1GHz. And RBW 1MHz for frequency above1GHz.

Radiated Spurious Emission Measurement Result (below 1GHz) (worst case) Band 2

Operation Mode	802.11n HT20 TX CH Low	Test Date	2015/08/12
Fundamental Frequency	5260MHz	Test By	Dino
Temperature	25	Pol	Ver./Hor
Humidity	65 %		

No	Freq MHz	Reading dBuV	Factor dB	Level dBuV/m	Limit dBuV/m	Over Limit dB	Remark	Pol V/H
1	101.78	48.65	-17.10	31.55	43.50	-11.95	Peak	VERTICAL
2	166.77	41.86	-12.43	29.43	43.50	-14.07	Peak	VERTICAL
3	250.19	40.65	-12.89	27.76	46.00	-18.24	Peak	VERTICAL
4	288.99	38.46	-11.38	27.08	46.00	-18.92	Peak	VERTICAL
5	700.27	30.37	-4.02	26.35	46.00	-19.65	Peak	VERTICAL
6	833.16	32.12	-1.69	30.43	46.00	-15.57	Peak	VERTICAL
1	83.35	45.34	-17.57	27.77	40.00	-12.23	Peak	HORIZONTAL
2	161.92	39.13	-12.17	26.96	43.50	-16.54	Peak	HORIZONTAL
3	250.19	43.89	-12.89	31.00	46.00	-15.00	Peak	HORIZONTAL
4	350.10	39.44	-10.11	29.33	46.00	-16.67	Peak	HORIZONTAL
5	450.01	33.78	-7.78	26.00	46.00	-20.00	Peak	HORIZONTAL
6	900.09	28.78	-0.50	28.28	46.00	-17.72	Peak	HORIZONTAL

Remark:

- 1 No further spurious emissions detected from the lowest internal frequency and 30MHz.
- 2 Measuring frequencies from the lowest internal frequency to the 1GHz.
- 3 Radiated emissions measured in frequency range from 9MHz to 1000MHz were made with an instrument detector setting 9-90KHz/110-490KHz using PK/AV and other Frequency Band using PK/QP
- 4 Measurement result within this frequency range shown “ - ” in the table above means the reading of emissions are attenuated more than 20dB below the permissible limits or the field strength is too small to be measured.
- 5 The IF bandwidth of SPA between 9kHz to 30MHz was 10kHz, VBW= 30kHz; between 30MHz to 1GHz was 100KHz, VBW=300KHz.

Radiated Spurious Emission Measurement Result (below 1GHz)

Operation Mode	802.11n HT20 TX CH Mid	Test Date	2015/08/12
Fundamental Frequency	5280MHz	Test By	Dino
Temperature	25	Pol	Ver./Hor
Humidity	65 %		

No	Freq MHz	Reading dBuV	Factor dB	Level dBuV/m	Limit dBuV/m	Over Limit dB	Remark	Pol V/H
1	97.90	46.92	-17.63	29.29	43.50	-14.21	Peak	VERTICAL
2	165.80	41.15	-12.38	28.77	43.50	-14.73	Peak	VERTICAL
3	250.19	39.52	-12.89	26.63	46.00	-19.37	Peak	VERTICAL
4	285.11	38.09	-11.48	26.61	46.00	-19.39	Peak	VERTICAL
5	700.27	29.53	-4.02	25.51	46.00	-20.49	Peak	VERTICAL
6	833.16	29.88	-1.69	28.19	46.00	-17.81	Peak	VERTICAL
1	84.32	44.78	-17.75	27.03	40.00	-12.97	Peak	HORIZONTAL
2	167.74	38.76	-12.48	26.28	43.50	-17.22	Peak	HORIZONTAL
3	250.19	43.82	-12.89	30.93	46.00	-15.07	Peak	HORIZONTAL
4	350.10	40.54	-10.11	30.43	46.00	-15.57	Peak	HORIZONTAL
5	450.01	33.82	-7.78	26.04	46.00	-19.96	Peak	HORIZONTAL
6	700.27	31.22	-4.02	27.20	46.00	-18.80	Peak	HORIZONTAL

Remark:

- 1 No further spurious emissions detected from the lowest internal frequency and 30MHz.
- 2 Measuring frequencies from the lowest internal frequency to the 1GHz.
- 3 Radiated emissions measured in frequency range from 9MHz to 1000MHz were made with an instrument detector setting 9-90KHz/110-490KHz using PK/AV and other Frequency Band using PK/QP
- 4 Measurement result within this frequency range shown “ - ” in the table above means the reading of emissions are attenuated more than 20dB below the permissible limits or the field strength is too small to be measured.
- 5 The IF bandwidth of SPA between 9kHz to 30MHz was 10kHz, VBW= 30kHz; between 30MHz to 1GHz was 100KHz, VBW=300KHz.

Radiated Spurious Emission Measurement Result (below 1GHz)

Operation Mode	802.11n HT20 TX CH High	Test Date	2015/08/12
Fundamental Frequency	5320MHz	Test By	Dino
Temperature	25	Pol	Ver./Hor
Humidity	65 %		

No	Freq MHz	Reading dBuV	Factor dB	Level dBuV/m	Limit dBuV/m	Over Limit dB	Remark	Pol V/H
1	102.75	46.58	-16.97	29.61	43.50	-13.89	Peak	VERTICAL
2	167.74	41.44	-12.48	28.96	43.50	-14.54	Peak	VERTICAL
3	250.19	39.28	-12.89	26.39	46.00	-19.61	Peak	VERTICAL
4	499.48	30.29	-7.46	22.83	46.00	-23.17	Peak	VERTICAL
5	700.27	29.17	-4.02	25.15	46.00	-20.85	Peak	VERTICAL
6	833.16	30.19	-1.69	28.50	46.00	-17.50	Peak	VERTICAL
1	84.32	43.93	-17.75	26.18	40.00	-13.82	Peak	HORIZONTAL
2	154.16	37.52	-12.10	25.42	43.50	-18.08	Peak	HORIZONTAL
3	250.19	43.40	-12.89	30.51	46.00	-15.49	Peak	HORIZONTAL
4	350.10	39.59	-10.11	29.48	46.00	-16.52	Peak	HORIZONTAL
5	450.01	32.93	-7.78	25.15	46.00	-20.85	Peak	HORIZONTAL
6	700.27	30.23	-4.02	26.21	46.00	-19.79	Peak	HORIZONTAL

Remark:

- 1 No further spurious emissions detected from the lowest internal frequency and 30MHz.
- 2 Measuring frequencies from the lowest internal frequency to the 1GHz.
- 3 Radiated emissions measured in frequency range from 9MHz to 1000MHz were made with an instrument detector setting 9-90KHz/110-490KHz using PK/AV and other Frequency Band using PK/QP
- 4 Measurement result within this frequency range shown “ - ” in the table above means the reading of emissions are attenuated more than 20dB below the permissible limits or the field strength is too small to be measured.
- 5 The IF bandwidth of SPA between 9kHz to 30MHz was 10kHz, VBW= 30kHz; between 30MHz to 1GHz was 100KHz, VBW=300KHz.

Radiated Spurious Emission Measurement Result (below 1GHz) (worst case) Band 3

Operation Mode	802.11n HT20 TX CH Low	Test Date	2015/08/12
Fundamental Frequency	5500MHz	Test By	Dino
Temperature	25	Pol	Ver./Hor
Humidity	65 %		

No	Freq MHz	Reading dBuV	Factor dB	Level dBuV/m	Limit dBuV/m	Over Limit dB	Remark	Pol V/H
1	103.72	46.41	-16.85	29.56	43.50	-13.94	Peak	VERTICAL
2	166.77	42.28	-12.43	29.85	43.50	-13.65	Peak	VERTICAL
3	250.19	38.87	-12.89	25.98	46.00	-20.02	Peak	VERTICAL
4	279.29	37.28	-11.65	25.63	46.00	-20.37	Peak	VERTICAL
5	499.48	31.40	-7.46	23.94	46.00	-22.06	Peak	VERTICAL
6	833.16	32.12	-1.69	30.43	46.00	-15.57	Peak	VERTICAL
1	83.35	44.92	-17.57	27.35	40.00	-12.65	Peak	HORIZONTAL
2	166.77	38.10	-12.43	25.67	43.50	-17.83	Peak	HORIZONTAL
3	250.19	43.64	-12.89	30.75	46.00	-15.25	Peak	HORIZONTAL
4	350.10	39.29	-10.11	29.18	46.00	-16.82	Peak	HORIZONTAL
5	500.45	32.29	-7.45	24.84	46.00	-21.16	Peak	HORIZONTAL
6	700.27	31.03	-4.02	27.01	46.00	-18.99	Peak	HORIZONTAL

Remark:

- 1 No further spurious emissions detected from the lowest internal frequency and 30MHz.
- 2 Measuring frequencies from the lowest internal frequency to the 1GHz.
- 3 Radiated emissions measured in frequency range from 9MHz to 1000MHz were made with an instrument detector setting 9-90KHz/110-490KHz using PK/AV and other Frequency Band using PK/QP
- 4 Measurement result within this frequency range shown “ - ” in the table above means the reading of emissions are attenuated more than 20dB below the permissible limits or the field strength is too small to be measured.
- 5 The IF bandwidth of SPA between 9kHz to 30MHz was 10kHz, VBW= 30kHz; between 30MHz to 1GHz was 100KHz, VBW=300KHz.

Radiated Spurious Emission Measurement Result (below 1GHz)

Operation Mode	802.11n HT20 TX CH Mid	Test Date	2015/08/12
Fundamental Frequency	5580MHz	Test By	Dino
Temperature	25	Pol	Ver./Hor
Humidity	65 %		

No	Freq MHz	Reading dBuV	Factor dB	Level dBuV/m	Limit dBuV/m	Over Limit dB	Remark	Pol V/H
1	94.99	48.22	-18.06	30.16	43.50	-13.34	Peak	VERTICAL
2	164.83	41.56	-12.32	29.24	43.50	-14.26	Peak	VERTICAL
3	250.19	39.28	-12.89	26.39	46.00	-19.61	Peak	VERTICAL
4	455.83	29.76	-7.73	22.03	46.00	-23.97	Peak	VERTICAL
5	700.27	30.99	-4.02	26.97	46.00	-19.03	Peak	VERTICAL
6	833.16	31.24	-1.69	29.55	46.00	-16.45	Peak	VERTICAL
1	85.29	45.74	-17.93	27.81	40.00	-12.19	Peak	HORIZONTAL
2	157.07	39.35	-12.08	27.27	43.50	-16.23	Peak	HORIZONTAL
3	250.19	43.48	-12.89	30.59	46.00	-15.41	Peak	HORIZONTAL
4	350.10	40.20	-10.11	30.09	46.00	-15.91	Peak	HORIZONTAL
5	450.01	33.51	-7.78	25.73	46.00	-20.27	Peak	HORIZONTAL
6	700.27	30.37	-4.02	26.35	46.00	-19.65	Peak	HORIZONTAL

Remark:

- 1 No further spurious emissions detected from the lowest internal frequency and 30MHz.
- 2 Measuring frequencies from the lowest internal frequency to the 1GHz.
- 3 Radiated emissions measured in frequency range from 9MHz to 1000MHz were made with an instrument detector setting 9-90KHz/110-490KHz using PK/AV and other Frequency Band using PK/QP
- 4 Measurement result within this frequency range shown “ - ” in the table above means the reading of emissions are attenuated more than 20dB below the permissible limits or the field strength is too small to be measured.
- 5 The IF bandwidth of SPA between 9kHz to 30MHz was 10kHz, VBW= 30kHz; between 30MHz to 1GHz was 100KHz, VBW=300KHz.

Radiated Spurious Emission Measurement Result (below 1GHz)

Operation Mode	802.11n HT20 TX CH High	Test Date	2015/08/12
Fundamental Frequency	5720MHz	Test By	Dino
Temperature	25	Pol	Ver./Hor
Humidity	65 %		

No	Freq MHz	Reading dBuV	Factor dB	Level dBuV/m	Limit dBuV/m	Over Limit dB	Remark	Pol V/H
1	101.78	47.68	-17.10	30.58	43.50	-12.92	Peak	VERTICAL
2	167.74	41.83	-12.48	29.35	43.50	-14.15	Peak	VERTICAL
3	250.19	40.84	-12.89	27.95	46.00	-18.05	Peak	VERTICAL
4	273.47	38.70	-11.98	26.72	46.00	-19.28	Peak	VERTICAL
5	700.27	29.80	-4.02	25.78	46.00	-20.22	Peak	VERTICAL
6	833.16	31.88	-1.69	30.19	46.00	-15.81	Peak	VERTICAL
1	84.32	45.46	-17.75	27.71	40.00	-12.29	Peak	HORIZONTAL
2	159.98	39.14	-12.06	27.08	43.50	-16.42	Peak	HORIZONTAL
3	250.19	43.40	-12.89	30.51	46.00	-15.49	Peak	HORIZONTAL
4	350.10	39.26	-10.11	29.15	46.00	-16.85	Peak	HORIZONTAL
5	450.01	32.90	-7.78	25.12	46.00	-20.88	Peak	HORIZONTAL
6	700.27	30.87	-4.02	26.85	46.00	-19.15	Peak	HORIZONTAL

Remark:

- 1 No further spurious emissions detected from the lowest internal frequency and 30MHz.
- 2 Measuring frequencies from the lowest internal frequency to the 1GHz.
- 3 Radiated emissions measured in frequency range from 9MHz to 1000MHz were made with an instrument detector setting 9-90KHz/110-490KHz using PK/AV and other Frequency Band using PK/QP
- 4 Measurement result within this frequency range shown “ - ” in the table above means the reading of emissions are attenuated more than 20dB below the permissible limits or the field strength is too small to be measured.
- 5 The IF bandwidth of SPA between 9kHz to 30MHz was 10kHz, VBW= 30kHz; between 30MHz to 1GHz was 100KHz, VBW=300KHz.

Radiated Spurious Emission Measurement Result (above 1GHz) (worst case) Band2

Operation Mode	802.11n HT20 TX CH Low	Test Date	2015/08/12
Fundamental Frequency	5260MHz	Test By	Dino
Temperature	25	Humidity	60 %

No	Freq MHz	Reading dBuV	Factor dB	Level dBuV/m	Limit dBuV/m	Over Limit dB	Remark	Pol V/H
1	1791.00	61.07	-13.22	47.85	74.00	-26.15	Peak	VERTICAL
2	1994.00	61.83	-12.17	49.66	74.00	-24.34	Peak	VERTICAL
3	10520.00	35.62	7.88	43.50	54.00	-10.50	Average	VERTICAL
4	10520.00	44.99	7.88	52.87	74.00	-21.13	Peak	VERTICAL
1	1595.00	52.72	-14.27	38.45	74.00	-35.55	Peak	HORIZONTAL
2	1994.00	57.11	-12.17	44.94	74.00	-29.06	Peak	HORIZONTAL
3	10520.00	40.54	7.88	48.42	74.00	-25.58	Peak	HORIZONTAL

Remark:

- 1 Measuring frequencies from the lowest internal frequency to the 10th of fundamental frequency
- 2 Field strength limits for frequency above 1000MHz are based on average limits. However, Peak mode field strength shall not exceed the average limits specified plus 20dB.
- 3 Measurement of data within this frequency range shown “ - ” in the table above means the reading of emissions are attenuated more than 20dB below the permissible limits or the field strength is too small to be measured.
- 4 Spectrum Peak mode IF bandwidth Setting : 1GHz- 40GHz, RBW= 1MHz, Sweep time= 200 ms., the VBW setting was 3 MHz.
- 5 Spectrum AV mode if bandwidth Setting : 1GHz- 40GHz, RBW= 1MHz, VBW= 10Hz, Sweep time= 200 ms.

Radiated Spurious Emission Measurement Result (above 1GHz) (worst case)

Operation Mode	802.11n HT20 TX CH Mid	Test Date	2015/08/12
Fundamental Frequency	5280MHz	Test By	Dino
Temperature	25	Humidity	60 %

No	Freq MHz	Reading dBuV	Factor dB	Level dBuV/m	Limit dBuV/m	Over Limit dB	Remark	Pol V/H
1	1497.00	66.49	-14.79	51.70	74.00	-22.30	Peak	VERTICAL
2	1994.00	61.96	-12.17	49.79	74.00	-24.21	Peak	VERTICAL
3	10560.00	43.08	7.88	50.96	74.00	-23.04	Peak	VERTICAL
1	1595.00	53.12	-14.27	38.85	74.00	-35.15	Peak	HORIZONTAL
2	1994.00	58.44	-12.17	46.27	74.00	-27.73	Peak	HORIZONTAL
3	10560.00	41.18	7.88	49.06	74.00	-24.94	Peak	HORIZONTAL

Remark:

- 1 Measuring frequencies from the lowest internal frequency to the 10th of fundamental frequency
- 2 Field strength limits for frequency above 1000MHz are based on average limits. However, Peak mode field strength shall not exceed the average limits specified plus 20dB.
- 3 Measurement of data within this frequency range shown “ - ” in the table above means the reading of emissions are attenuated more than 20dB below the permissible limits or the field strength is too small to be measured.
- 4 Spectrum Peak mode IF bandwidth Setting : 1GHz- 40GHz, RBW= 1MHz, Sweep time= 200 ms., the VBW setting was 3 MHz.
- 5 Spectrum AV mode if bandwidth Setting : 1GHz- 40GHz, RBW= 1MHz, VBW= 10Hz, Sweep time= 200 ms.

Radiated Spurious Emission Measurement Result (above 1GHz) (worst case)

Operation Mode	802.11n HT20 TX CH High	Test Date	2015/08/12
Fundamental Frequency	5320MHz	Test By	Dino
Temperature	25	Humidity	60 %

No	Freq MHz	Reading dBuV	Factor dB	Level dBuV/m	Limit dBuV/m	Over Limit dB	Remark	Pol V/H
1	1791.00	56.93	-13.22	43.71	74.00	-30.29	Peak	VERTICAL
2	1994.00	63.64	-12.17	51.47	74.00	-22.53	Peak	VERTICAL
3	10640.00	43.14	7.91	51.05	74.00	-22.95	Peak	VERTICAL
1	1497.00	55.68	-14.79	40.89	74.00	-33.11	Peak	HORIZONTAL
2	1994.00	56.74	-12.17	44.57	74.00	-29.43	Peak	HORIZONTAL
3	10640.00	40.15	7.91	48.06	74.00	-25.94	Peak	HORIZONTAL

Remark:

- 1 Measuring frequencies from the lowest internal frequency to the 10th of fundamental frequency
- 2 Field strength limits for frequency above 1000MHz are based on average limits. However, Peak mode field strength shall not exceed the average limits specified plus 20dB.
- 3 Measurement of data within this frequency range shown “ - ” in the table above means the reading of emissions are attenuated more than 20dB below the permissible limits or the field strength is too small to be measured.
- 4 Spectrum Peak mode IF bandwidth Setting : 1GHz- 40GHz, RBW= 1MHz, Sweep time= 200 ms., the VBW setting was 3 MHz.
- 5 Spectrum AV mode if bandwidth Setting : 1GHz- 40GHz, RBW= 1MHz, VBW= 10Hz, Sweep time= 200 ms.

Radiated Spurious Emission Measurement Result (above 1GHz) (worst case) Band3

Operation Mode	802.11n HT20 TX CH Low	Test Date	2015/08/12
Fundamental Frequency	5500MHz	Test By	Dino
Temperature	25	Humidity	60 %

No	Freq MHz	Reading dBuV	Factor dB	Level dBuV/m	Limit dBuV/m	Over Limit dB	Remark	Pol V/H
1	1798.00	60.81	-13.19	47.62	74.00	-26.38	Peak	VERTICAL
2	2001.00	63.98	-12.14	51.84	74.00	-22.16	Peak	VERTICAL
3	11000.00	42.55	7.98	50.53	74.00	-23.47	Peak	VERTICAL
1	1497.00	55.46	-14.79	40.67	74.00	-33.33	Peak	HORIZONTAL
2	2001.00	55.88	-12.14	43.74	74.00	-30.26	Peak	HORIZONTAL
3	11000.00	40.69	7.98	48.67	74.00	-25.33	Peak	HORIZONTAL

Remark:

- 1 Measuring frequencies from the lowest internal frequency to the 10th of fundamental frequency
- 2 Field strength limits for frequency above 1000MHz are based on average limits. However, Peak mode field strength shall not exceed the average limits specified plus 20dB.
- 3 Measurement of data within this frequency range shown “ - ” in the table above means the reading of emissions are attenuated more than 20dB below the permissible limits or the field strength is too small to be measured.
- 4 Spectrum Peak mode IF bandwidth Setting : 1GHz- 40GHz, RBW= 1MHz, Sweep time= 200 ms., the VBW setting was 3 MHz.
- 5 Spectrum AV mode if bandwidth Setting : 1GHz- 40GHz, RBW= 1MHz, VBW= 10Hz, Sweep time= 200 ms.

Radiated Spurious Emission Measurement Result (above 1GHz) (worst case)

Operation Mode	802.11n HT20 TX CH Mid	Test Date	2015/08/12
Fundamental Frequency	5580MHz	Test By	Dino
Temperature	25	Humidity	60 %

No	Freq MHz	Reading dBuV	Factor dB	Level dBuV/m	Limit dBuV/m	Over Limit dB	Remark	Pol V/H
1	1791.00	60.15	-13.22	46.93	74.00	-27.07	Peak	VERTICAL
2	1994.00	62.23	-12.17	50.06	74.00	-23.94	Peak	VERTICAL
3	11160.00	41.59	7.93	49.52	74.00	-24.48	Peak	VERTICAL
1	1497.00	55.52	-14.79	40.73	74.00	-33.27	Peak	HORIZONTAL
2	2001.00	55.60	-12.14	43.46	74.00	-30.54	Peak	HORIZONTAL
3	11160.00	41.60	7.93	49.53	74.00	-24.47	Peak	HORIZONTAL

Remark:

- 1 Measuring frequencies from the lowest internal frequency to the 10th of fundamental frequency
- 2 Field strength limits for frequency above 1000MHz are based on average limits. However, Peak mode field strength shall not exceed the average limits specified plus 20dB.
- 3 Measurement of data within this frequency range shown “ - ” in the table above means the reading of emissions are attenuated more than 20dB below the permissible limits or the field strength is too small to be measured.
- 4 Spectrum Peak mode IF bandwidth Setting : 1GHz- 40GHz, RBW= 1MHz, Sweep time= 200 ms., the VBW setting was 3 MHz.
- 5 Spectrum AV mode if bandwidth Setting : 1GHz- 40GHz, RBW= 1MHz, VBW= 10Hz, Sweep time= 200 ms.

Radiated Spurious Emission Measurement Result (above 1GHz) (worst case)

Operation Mode	802.11n HT20 TX CH High	Test Date	2015/08/12
Fundamental Frequency	5720MHz	Test By	Dino
Temperature	25	Humidity	60 %

No	Freq MHz	Reading dBuV	Factor dB	Level dBuV/m	Limit dBuV/m	Over Limit dB	Remark	Pol V/H
1	1994.00	39.45	-12.17	27.28	54.00	-26.72	Average	VERTICAL
2	1994.00	67.07	-12.17	54.90	74.00	-19.10	Peak	VERTICAL
3	11440.00	44.34	7.87	52.21	74.00	-21.79	Peak	VERTICAL
1	1994.00	57.82	-12.17	45.65	74.00	-28.35	Peak	HORIZONTAL
2	3275.00	49.68	-8.44	41.24	74.00	-32.76	Peak	HORIZONTAL
3	11440.00	40.60	7.87	48.47	74.00	-25.53	Peak	HORIZONTAL

Remark:

- 1 Measuring frequencies from the lowest internal frequency to the 10th of fundamental frequency
- 2 Field strength limits for frequency above 1000MHz are based on average limits. However, Peak mode field strength shall not exceed the average limits specified plus 20dB.
- 3 Measurement of data within this frequency range shown “ - ” in the table above means the reading of emissions are attenuated more than 20dB below the permissible limits or the field strength is too small to be measured.
- 4 Spectrum Peak mode IF bandwidth Setting : 1GHz- 40GHz, RBW= 1MHz, Sweep time= 200 ms., the VBW setting was 3 MHz.
- 5 Spectrum AV mode if bandwidth Setting : 1GHz- 40GHz, RBW= 1MHz, VBW= 10Hz, Sweep time= 200 ms.

Band Edges test: 5250MHz – 5350MHz, 802.11a mode

Operation Mode TX CH Low
Fundamental Frequency 5260 MHz
Temperature 25

Test Date 2015/08/12
Test By Dino
Humidity 65 %

No	Freq MHz	Reading dBuV	Factor dB	Level dBuV/m	Limit dBuV/m	Over Limit dB	Remark	Pol V/H
1	5000.76	55.33	-2.75	52.58	54.00	-1.42	Average	VERTICAL
2	5000.76	57.94	-2.75	55.19	74.00	-18.81	Peak	VERTICAL
3	5150.00	46.28	-2.40	43.88	74.00	-30.12	Peak	VERTICAL
1	5150.00	40.13	-2.40	37.73	54.00	-16.27	Average	HORIZONTAL
2	5150.00	55.00	-2.40	52.60	74.00	-21.40	Peak	HORIZONTAL

Operation Mode TX CH High
Fundamental Frequency 5320MHz
Temperature 25

Test Date 2015/08/12
Test By Dino
Humidity 65 %

No	Freq MHz	Reading dBuV	Factor dB	Level dBuV/m	Limit dBuV/m	Over Limit dB	Remark	Pol V/H
1	5350.00	51.68	-1.94	49.74	74.00	-24.26	Peak	VERTICAL
2	5404.16	46.93	-1.81	45.12	54.00	-8.88	Average	VERTICAL
3	5404.16	56.62	-1.81	54.81	74.00	-19.19	Peak	VERTICAL
1	5350.00	49.77	-1.94	47.83	74.00	-26.17	Peak	HORIZONTAL
2	5355.36	52.72	-1.92	50.80	74.00	-23.20	Peak	HORIZONTAL

Remark:

- 1 Measuring frequencies from the lowest internal frequency to the 10th of fundamental frequency
- 2 Field strength limits for frequency above 1000MHz are based on average limits. However, Peak mode field strength shall not exceed the average limits specified plus 20dB.
- 3 Measurement of data within this frequency range shown “ - ” in the table above means the reading of emissions are attenuated more than 20dB below the permissible limits or the field strength is too small to be measured.
- 4 Spectrum Peak mode IF bandwidth Setting : 1GHz- 40GHz, RBW= 1MHz, Sweep time= 200 ms., the VBW setting was 3 MHz.
- 5 Spectrum AV mode if bandwidth Setting : 1GHz- 40GHz, RBW= 1MHz, VBW= 10Hz, Sweep time= 200 ms.

Band Edges test: 5250MHz – 5350MHz, 802.11n HT20 mode, Combined

Operation Mode	TX CH Low	Test Date	2015/08/12
Fundamental Frequency	5260 MHz	Test By	Dino
Temperature	25	Humidity	65 %

No	Freq MHz	Reading dBuV	Factor dB	Level dBuV/m	Limit dBuV/m	Over Limit dB	Remark	Pol V/H
1	5000.40	56.06	-2.75	53.31	54.00	-0.69	Average	VERTICAL
2	5000.40	59.17	-2.75	56.42	74.00	-17.58	Peak	VERTICAL
3	5150.00	52.44	-2.40	50.04	74.00	-23.96	Peak	VERTICAL
1	5150.00	40.13	-2.40	37.73	54.00	-16.27	Average	HORIZONTAL
2	5150.00	55.00	-2.40	52.60	74.00	-21.40	Peak	HORIZONTAL

Operation Mode	TX CH High	Test Date	2015/08/12
Fundamental Frequency	5320MHz	Test By	Dino
Temperature	25	Humidity	65 %

No	Freq MHz	Reading dBuV	Factor dB	Level dBuV/m	Limit dBuV/m	Over Limit dB	Remark	Pol V/H
1	5350.00	51.68	-1.94	49.74	74.00	-24.26	Peak	VERTICAL
2	5404.16	46.93	-1.81	45.12	54.00	-8.88	Average	VERTICAL
3	5404.16	56.62	-1.81	54.81	74.00	-19.19	Peak	VERTICAL
1	5350.00	49.77	-1.94	47.83	74.00	-26.17	Peak	HORIZONTAL
2	5355.36	52.72	-1.92	50.80	74.00	-23.20	Peak	HORIZONTAL

Remark:

- 1 Measuring frequencies from the lowest internal frequency to the 10th of fundamental frequency
- 2 Field strength limits for frequency above 1000MHz are based on average limits. However, Peak mode field strength shall not exceed the average limits specified plus 20dB.
- 3 Measurement of data within this frequency range shown “ - ” in the table above means the reading of emissions are attenuated more than 20dB below the permissible limits or the field strength is too small to be measured.
- 4 Spectrum Peak mode IF bandwidth Setting : 1GHz- 40GHz, RBW= 1MHz, Sweep time= 200 ms., the VBW setting was 3 MHz.
- 5 Spectrum AV mode if bandwidth Setting : 1GHz- 40GHz, RBW= 1MHz, VBW= 10Hz, Sweep time= 200 ms.

Band Edges test: 5250MHz – 5350MHz, 802.11n HT40 mode , Combined

Operation Mode	TX CH Low	Test Date	2015/08/12
Fundamental Frequency	5270 MHz	Test By	Dino
Temperature	25	Humidity	65 %

No	Freq MHz	Reading dBuV	Factor dB	Level dBuV/m	Limit dBuV/m	Over Limit dB	Remark	Pol V/H
1	5000.80	55.98	-2.75	53.23	54.00	-0.77	Average	VERTICAL
2	5000.80	59.48	-2.75	56.73	74.00	-17.27	Peak	VERTICAL
3	5150.00	53.83	-2.40	51.43	74.00	-22.57	Peak	VERTICAL
1	5000.80	54.69	-2.75	51.94	74.00	-22.06	Peak	HORIZONTAL
2	5150.00	52.37	-2.40	49.97	74.00	-24.03	Peak	HORIZONTAL

Operation Mode	TX CH High	Test Date	2015/08/12
Fundamental Frequency	5310MHz	Test By	Dino
Temperature	25	Humidity	65 %

No	Freq MHz	Reading dBuV	Factor dB	Level dBuV/m	Limit dBuV/m	Over Limit dB	Remark	Pol V/H
1	5350.00	48.81	-1.94	46.87	54.00	-7.13	Average	VERTICAL
2	5350.00	61.29	-1.94	59.35	74.00	-14.65	Peak	VERTICAL
3	5358.12	42.77	-1.92	40.85	54.00	-13.15	Average	VERTICAL
4	5358.12	60.13	-1.92	58.21	74.00	-15.79	Peak	VERTICAL
1	5350.00	50.62	-1.94	48.68	74.00	-25.32	Peak	HORIZONTAL
2	5376.84	52.39	-1.87	50.52	74.00	-23.48	Peak	HORIZONTAL

Remark:

- 1 Measuring frequencies from the lowest internal frequency to the 10th of fundamental frequency
- 2 Field strength limits for frequency above 1000MHz are based on average limits. However, Peak mode field strength shall not exceed the average limits specified plus 20dB.
- 3 Measurement of data within this frequency range shown “ - ” in the table above means the reading of emissions are attenuated more than 20dB below the permissible limits or the field strength is too small to be measured.
- 4 Spectrum Peak mode IF bandwidth Setting : 1GHz- 40GHz, RBW= 1MHz, Sweep time= 200 ms., the VBW setting was 3 MHz.
- 5 Spectrum AV mode if bandwidth Setting : 1GHz- 40GHz, RBW= 1MHz, VBW= 10Hz, Sweep time= 200 ms.

Band Edges test: 5250MHz – 5350MHz, 802.11AC HT80 mode , Combined

Operation Mode	TX CH Low	Test Date	2015/08/12
Fundamental Frequency	5290 MHz	Test By	Dino
Temperature	25	Humidity	65 %

No	Freq MHz	Reading dBuV	Factor dB	Level dBuV/m	Limit dBuV/m	Over Limit dB	Remark	Pol V/H
1	5000.65	56.01	-2.75	53.26	54.00	-0.74	Average	VERTICAL
2	5000.65	59.67	-2.75	56.92	74.00	-17.08	Peak	VERTICAL
3	5150.00	52.99	-2.40	50.59	74.00	-23.41	Peak	VERTICAL
1	5134.10	44.82	-2.44	42.38	54.00	-11.62	Average	HORIZONTAL
2	5134.10	55.08	-2.44	52.64	74.00	-21.36	Peak	HORIZONTAL
3	5150.00	53.72	-2.40	51.32	74.00	-22.68	Peak	HORIZONTAL

Remark:

- 1 Measuring frequencies from the lowest internal frequency to the 10th of fundamental frequency
- 2 Field strength limits for frequency above 1000MHz are based on average limits. However, Peak mode field strength shall not exceed the average limits specified plus 20dB.
- 3 Measurement of data within this frequency range shown “ - ” in the table above means the reading of emissions are attenuated more than 20dB below the permissible limits or the field strength is too small to be measured.
- 4 Spectrum Peak mode IF bandwidth Setting : 1GHz- 40GHz, RBW= 1MHz, Sweep time= 200 ms., the VBW setting was 3 MHz.
- 5 Spectrum AV mode if bandwidth Setting : 1GHz- 40GHz, RBW= 1MHz, VBW= 10Hz, Sweep time= 200 ms.

Band Edges test: 5470MHz – 5725MHz, 802.11a mode

Operation Mode	TX CH Low	Test Date	2015/08/12
Fundamental Frequency	5500 MHz	Test By	Dino
Temperature	25	Humidity	65 %

No	Freq MHz	Reading dBuV	Factor dB	Level dBuV/m	Limit dBuV/m	Over Limit dB	Remark	Pol V/H
1	5417.52	48.50	-1.78	46.72	74.00	-27.28	Peak	VERTICAL
2	5470.00	45.15	-1.66	43.49	74.00	-30.51	Peak	VERTICAL
1	5414.64	48.39	-1.78	46.61	74.00	-27.39	Peak	HORIZONTAL
2	5470.00	43.92	-1.66	42.26	74.00	-31.74	Peak	HORIZONTAL

Remark:

- 1 Measuring frequencies from the lowest internal frequency to the 10th of fundamental frequency
- 2 Field strength limits for frequency above 1000MHz are based on average limits. However, Peak mode field strength shall not exceed the average limits specified plus 20dB.
- 3 Measurement of data within this frequency range shown “ - ” in the table above means the reading of emissions are attenuated more than 20dB below the permissible limits or the field strength is too small to be measured.
- 4 Spectrum Peak mode IF bandwidth Setting : 1GHz- 26GHz, RBW= 1MHz, Sweep time= 200 ms., the VBW setting was 3 MHz.
- 5 Spectrum AV mode if bandwidth Setting : 1GHz- 26GHz, RBW= 1MHz, VBW= 10Hz, Sweep time= 200 ms.

Band Edges test: 5470MHz – 5725MHz, 802.11n HT20 mode, Combined

Operation Mode	TX CH Low	Test Date	2015/08/12
Fundamental Frequency	5500 MHz	Test By	Dino
Temperature	25	Humidity	65 %

No	Freq MHz	Reading dBuV	Factor dB	Level dBuV/m	Limit dBuV/m	Over Limit dB	Remark	Pol V/H
1	5422.44	47.04	-1.77	45.27	54.00	-8.73	Average	VERTICAL
2	5422.44	57.06	-1.77	55.29	74.00	-18.71	Peak	VERTICAL
3	5470.00	42.47	-1.66	40.81	54.00	-13.19	Average	VERTICAL
4	5470.00	53.93	-1.66	52.27	74.00	-21.73	Peak	VERTICAL
1	5413.56	52.99	-1.78	51.21	74.00	-22.79	Peak	HORIZONTAL
2	5470.00	49.95	-1.66	48.29	74.00	-25.71	Peak	HORIZONTAL

Remark:

- 1 Measuring frequencies from the lowest internal frequency to the 10th of fundamental frequency
- 2 Field strength limits for frequency above 1000MHz are based on average limits. However, Peak mode field strength shall not exceed the average limits specified plus 20dB.
- 3 Measurement of data within this frequency range shown “ - ” in the table above means the reading of emissions are attenuated more than 20dB below the permissible limits or the field strength is too small to be measured.
- 4 Spectrum Peak mode IF bandwidth Setting : 1GHz- 26GHz, RBW= 1MHz, Sweep time= 200 ms., the VBW setting was 3 MHz.
- 5 Spectrum AV mode if bandwidth Setting : 1GHz- 26GHz, RBW= 1MHz, VBW= 10Hz, Sweep time= 200 ms.

Band Edges test: 5470MHz – 5725MHz, 802.11n HT40 mode, Combined

Operation Mode	TX CH Low	Test Date	2015/08/12
Fundamental Frequency	5510 MHz	Test By	Dino
Temperature	25	Humidity	65 %

No	Freq MHz	Reading dBuV	Factor dB	Level dBuV/m	Limit dBuV/m	Over Limit dB	Remark	Pol V/H
1	5469.02	51.27	-1.66	49.61	54.00	-4.39	Average	VERTICAL
2	5469.02	66.65	-1.66	64.99	74.00	-9.01	Peak	VERTICAL
3	5470.00	49.68	-1.66	48.02	54.00	-5.98	Average	VERTICAL
4	5470.00	63.36	-1.66	61.70	74.00	-12.30	Peak	VERTICAL
1	5470.00	43.45	-1.66	41.79	54.00	-12.21	Average	HORIZONTAL
2	5470.00	54.22	-1.66	52.56	74.00	-21.44	Peak	HORIZONTAL

Remark:

- 1 Measuring frequencies from the lowest internal frequency to the 10th of fundamental frequency
- 2 Field strength limits for frequency above 1000MHz are based on average limits. However, Peak mode field strength shall not exceed the average limits specified plus 20dB.
- 3 Measurement of data within this frequency range shown “ - ” in the table above means the reading of emissions are attenuated more than 20dB below the permissible limits or the field strength is too small to be measured.
- 4 Spectrum Peak mode IF bandwidth Setting : 1GHz- 26GHz, RBW= 1MHz, Sweep time= 200 ms., the VBW setting was 3 MHz.
- 5 Spectrum AV mode if bandwidth Setting : 1GHz- 26GHz, RBW= 1MHz, VBW= 10Hz, Sweep time= 200 ms.

Band Edges test: 5470MHz – 5725MHz, 802.11AC HT80 mode, Combined

Operation Mode	TX CH	Test Date	2015/08/12
Fundamental Frequency	5530 MHz	Test By	Dino
Temperature	25	Humidity	65 %

No	Freq MHz	Reading dBuV	Factor dB	Level dBuV/m	Limit dBuV/m	Over Limit dB	Remark	Pol V/H
1	5470.00	52.60	-1.66	50.94	54.00	-3.06	Average	VERTICAL
2	5470.00	66.23	-1.66	64.57	74.00	-9.43	Peak	VERTICAL
1	5462.28	42.41	-1.67	40.74	54.00	-13.26	Average	HORIZONTAL
2	5462.28	56.62	-1.67	54.95	74.00	-19.05	Peak	HORIZONTAL
3	5470.00	52.89	-1.66	51.23	74.00	-22.77	Peak	HORIZONTAL

Remark:

- 1 Measuring frequencies from the lowest internal frequency to the 10th of fundamental frequency
- 2 Field strength limits for frequency above 1000MHz are based on average limits. However, Peak mode field strength shall not exceed the average limits specified plus 20dB.
- 3 Measurement of data within this frequency range shown “ - ” in the table above means the reading of emissions are attenuated more than 20dB below the permissible limits or the field strength is too small to be measured.
- 4 Spectrum Peak mode IF bandwidth Setting : 1GHz- 26GHz, RBW= 1MHz, Sweep time= 200 ms., the VBW setting was 3 MHz.
- 5 Spectrum AV mode if bandwidth Setting : 1GHz- 26GHz, RBW= 1MHz, VBW= 10Hz, Sweep time= 200 ms.

8. TRANSMISSION IN THE ABSENCE OF DATA

8.1 Standard Applicable

According to §15.407(c)

The device shall automatically discontinue transmission in case of either absence of information to transmit or operational failure. These provisions are not intended to preclude the transmission of control or signaling information or the use of repetitive codes used by certain digital technologies to complete frame or burst intervals. Applicants shall include in their application for equipment authorization a description of how this requirement is met.

8.2 Result:

No non-compliance noted:

Refer to the theory of operation.

9. FREQUENCY STABILITY

9.1 Standard Applicable

According to §15.407 (g) Manufacturers of U-NII devices are responsible for ensuring frequency stability such that an emission is maintained within the band of operation under all conditions of normal operation as specified in the user's manual.

9.2 Result:

No non-compliance noted:

± 20 ppm ppm was defined in product specification.

10. ANTENNA REQUIREMENT

10.1 Standard Applicable

According to §15.203, Antenna requirement.

An intentional radiator shall be designed to ensure that no antenna other than that furnished by the responsible party shall be used with the device. The use of a permanently attached antenna or of an antenna that uses a unique coupling to the intentional radiator shall be considered sufficient to comply with the provisions of this Section. The manufacturer may design the unit so that a broken antenna can be replaced by the user, but the use of a standard antenna jack or electrical connector is prohibited. This requirement does not apply to carrier current devices or to devices operated under the provisions of Sections 15.211, 15.213, 15.217, 15.219, or 15.221. Further, this requirement does not apply to intentional radiators that must be professionally installed, such as perimeter protection systems and some field disturbance sensors, or to other intentional radiators which, in accordance with Section 15.31(d), must be measured at the installation side. However, the installer shall be responsible for ensuring that the proper antenna is employed so that the limits in this Part are not exceeded.

10.2 Antenna Connected Construction

The directional gains of antenna used for transmitting is below table, and the antenna connector is designed with unique type RF connector and no consideration of replacement. Please see EUT photo and antenna spec. for details.

Antenna Designation:

	Manufacturer	Type	Gain (2.4GHz)	Gain (5GHz)
Ant 1	Suzhou Anjie Technology Col, Ltd.	Reversed SMA type dipole Antenna	3.63dBi	6.12dBi
Ant 2	ADVANCED	Reversed SMA type dipole Antenna	3.5dBi	4.6dBi

According to KDB662911 D01 MU-MIMO signals could be considered uncorrelated for purposes of directional gain computation.

3Tx MIMO,

Directional gain = G_{ANT} = Beamforming gain $10\log(3) = 4.77\text{dBi}$

11. TPC and DFS MEASUREMENT

11.1 TPC: Standard Applicable

According to §15.407(h)(1), Transmit power control (TPC). U-NII devices operating in the 5.25-5.35 GHz band and the 5.47-5.725 GHz band shall employ a TPC mechanism. The U-NII device is required to have the capability to operate at least 6 dB below the mean EIRP value of 30 dBm. A TPC mechanism is not required for systems with an e.i.r.p. of less than 500 mW.

11.1.1. Result: N/A, The output power is less than 500mW.

11.2 DFS: Standard Applicable

According to §15.407(h)(2), Radar Detection Function of Dynamic Frequency Selection (DFS). U-NII devices operating in the 5.25-5.35 GHz and 5.47-5.725 GHz bands shall employ a DFS radar detection.

11.2.1. Limit

Table 1: Applicability of DFS requirements prior to use of a channel

Requirement	Operational Mode		
	Master	Client Without Radar Detection	Client With Radar Detection
<i>Non-Occupancy Period</i>	Yes	Not required	Yes
<i>DFS Detection Threshold</i>	Yes	Not required	Yes
<i>Channel Availability Check Time</i>	Yes	Not required	Not required
<i>U-NII Detection Bandwidth</i>	Yes	Not required	Yes

Table 2: Applicability of DFS requirements during normal operation

Requirement	Operational Mode	
	Master Device or Client with Radar Detection	Client Without Radar Detection
<i>DFS Detection Threshold</i>	Yes	Not required
<i>Channel Closing Transmission Time</i>	Yes	Yes
<i>Channel Move Time</i>	Yes	Yes
<i>U-NII Detection Bandwidth</i>	Yes	Not required

Table 3: DFS Detection Thresholds for Master Devices and Client Devices With Radar Detection

Maximum Transmit Power	Value (See Notes 1, 2, and 3)
EIRP \geq 200 milliwatt	-64 dBm
EIRP < 200 milliwatt and power spectral density < 10 dBm/MHz	-62 dBm
EIRP < 200 milliwatt that do not meet the power spectral density requirement	-64 dBm
<p>Note 1: This is the level at the input of the receiver assuming a 0 dBi receive antenna.</p> <p>Note 2: Throughout these test procedures an additional 1 dB has been added to the amplitude of the test transmission waveforms to account for variations in measurement equipment. This will ensure that the test signal is at or above the detection threshold level to trigger a DFS response.</p> <p>Note3: EIRP is based on the highest antenna gain. For MIMO devices refer to KDB Publication 662911 D01.</p>	

Table 4: DFS Response requirement values

Parameter	Value
<i>Non-occupancy period</i>	Minimum 30 minutes
<i>Channel Availability Check Time</i>	60 seconds
<i>Channel Move Time</i>	10 seconds See Note 1.
<i>Channel Closing Transmission Time</i>	200 milliseconds + an aggregate of 60 milliseconds over remaining 10 second period. See Notes 1 and 2.
<i>U-NII Detection Bandwidth</i>	Minimum 100% of the U-NII 99% transmission power bandwidth. See Note 3.
<p>Note 1: <i>Channel Move Time</i> and the <i>Channel Closing Transmission Time</i> should be performed with Radar Type 0. The measurement timing begins at the end of the Radar Type 0 burst.</p> <p>Note 2: The <i>Channel Closing Transmission Time</i> is comprised of 200 milliseconds starting at the beginning of the <i>Channel Move Time</i> plus any additional intermittent control signals required to facilitate a <i>Channel</i> move (an aggregate of 60 milliseconds) during the remainder of the 10 second period. The aggregate duration of control signals will not count quiet periods in between transmissions.</p> <p>Note 3: During the <i>U-NII Detection Bandwidth</i> detection test, radar type 0 should be used. For each frequency step the minimum percentage of detection is 90 percent. Measurements are performed with no data traffic.</p>	

Table 5: Radar Test Waveforms

Short Pulse Radar

Radar Type	Pulse Width (μsec)	PRI (μsec)	Number of Pulses	Minimum Percentage of Successful Detection	Minimum Number of Trials
0	1	1428	18	See Note 1	See Note 1
1	1	Test A: 15 unique PRI values randomly selected from the list of 23 PRI values in Table 5a	Roundup $\left\{ \begin{matrix} \left(\frac{1}{360} \right) \cdot \\ \left(\frac{19 \cdot 10^6}{PRI_{\mu sec}} \right) \end{matrix} \right\}$	60%	30
		Test B: 15 unique PRI values randomly selected within the range of 518-3066 μsec, with a minimum increment of 1 μsec, excluding PRI values selected in Test A			
2	1-5	150-230	23-29	60%	30
3	6-10	200-500	16-18	60%	30
4	11-20	200-500	12-16	60%	30
Aggregate (Radar Types 1-4)				80%	120

Long Pulse Radar

Radar Type	Pulse Width (μsec)	Chirp Width (MHz)	PRI (μsec)	Number of Pulses per Burst	Number of Bursts	Minimum Percentage of Successful Detection	Minimum Trials
5	50-100	5-20	1000-2000	1-3	8-20	80%	30

Frequency Hopping Radar

Radar Type	Pulse Width (μsec)	PRI (μsec)	Pulses per Hop	Hopping Rate (kHz)	Hopping Sequence Length (msec)	Minimum Percentage of Successful Detection	Minimum Trials
6	1	333	9	.333	300	70%	30

Table 5: Radar Test mode

Additional requirements for devices with multiple bandwidth modes	Master Device or Client with Radar Detection	Client Without Radar Detection
<i>U-NII Detection Bandwidth and Statistical Performance Check</i>	All BW modes must be tested	Not required
<i>Channel Move Time and Channel Closing Transmission Time</i>	Test using widest BW mode available	Test using the widest BW mode available for the link
<i>All other tests</i>	Any single BW mode	Not required
<p>Note: Frequencies selected for statistical performance check (Section 7.8.4) should include several frequencies within the radar detection bandwidth and frequencies near the edge of the radar detection bandwidth. For 802.11 devices it is suggested to select frequencies in each of the bonded 20 MHz channels and the channel center frequency.</p>		

11.2.2. Test Setup

Setup for Master with injection at the Master

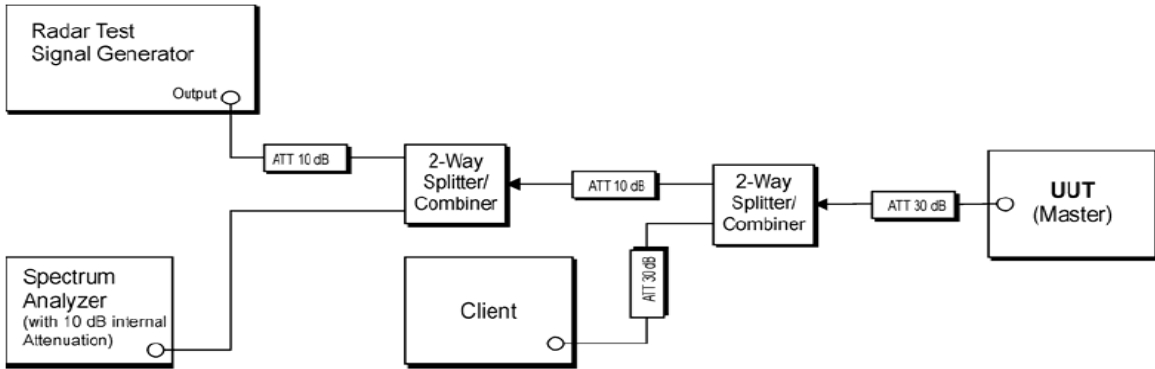

Setup for Client with injection at the Master

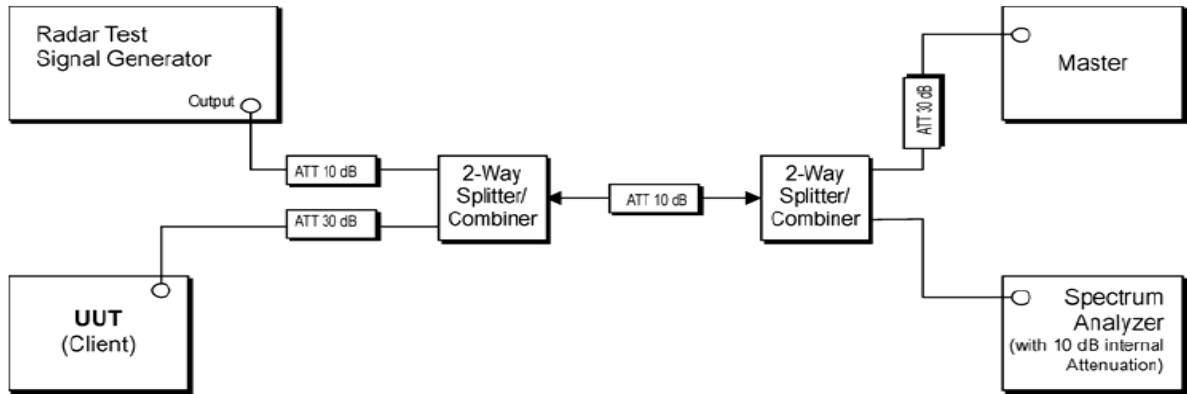

Setup for Client with injection at the Client

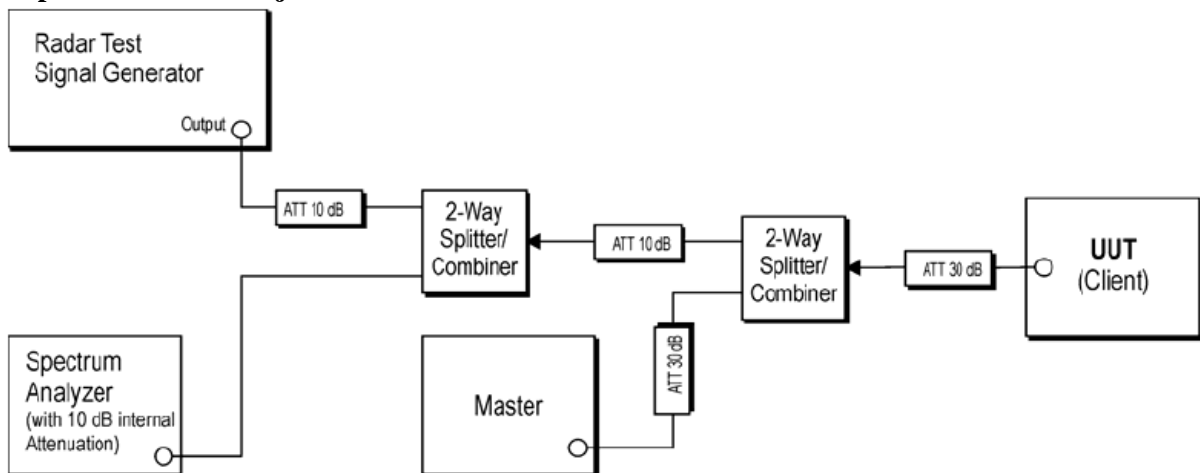

11.3 Test Equipment Used:

Refer to section 6.3 for details.

11.3.1. Description of EUT :

WLAN traffic is generated by streaming the mpeg file from the EUT to slave in full monitor video mode using the media player.

Threshold level is worst -64dBm to all DFS item

11.4 Test results

Refer to next page for plots.

5250MHz ~ 5350MHz

Calibration plots for each of the required radar waveforms

Radar type 0

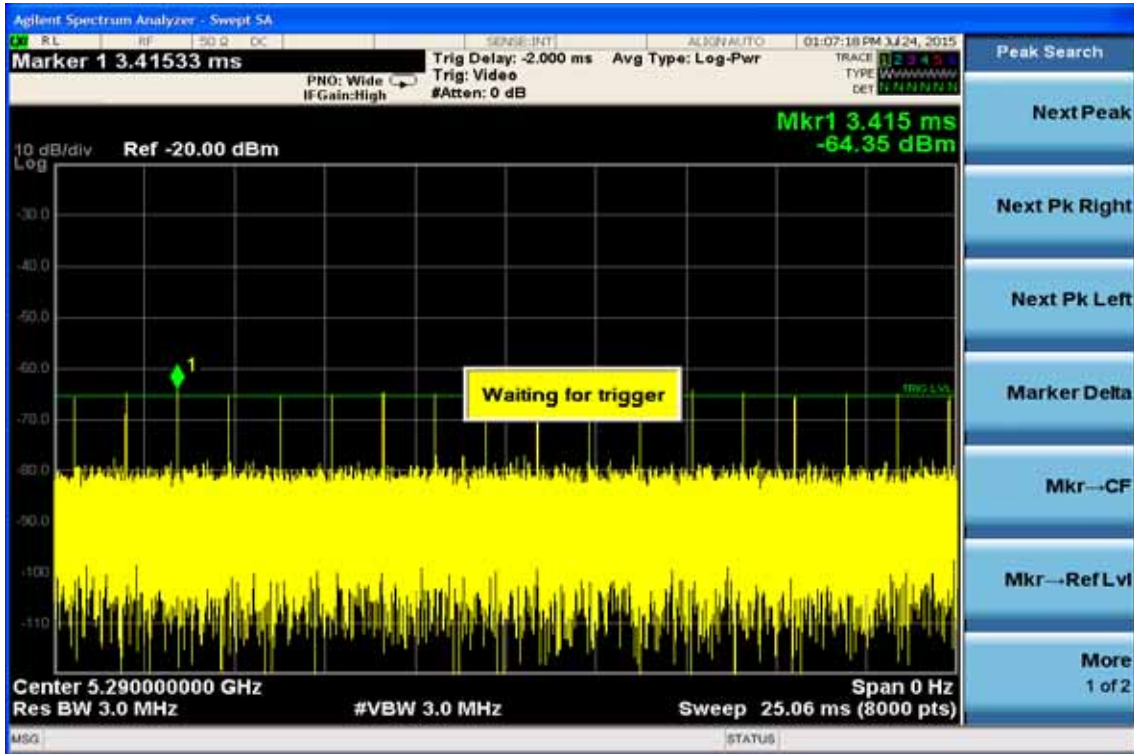

Radar type 1A

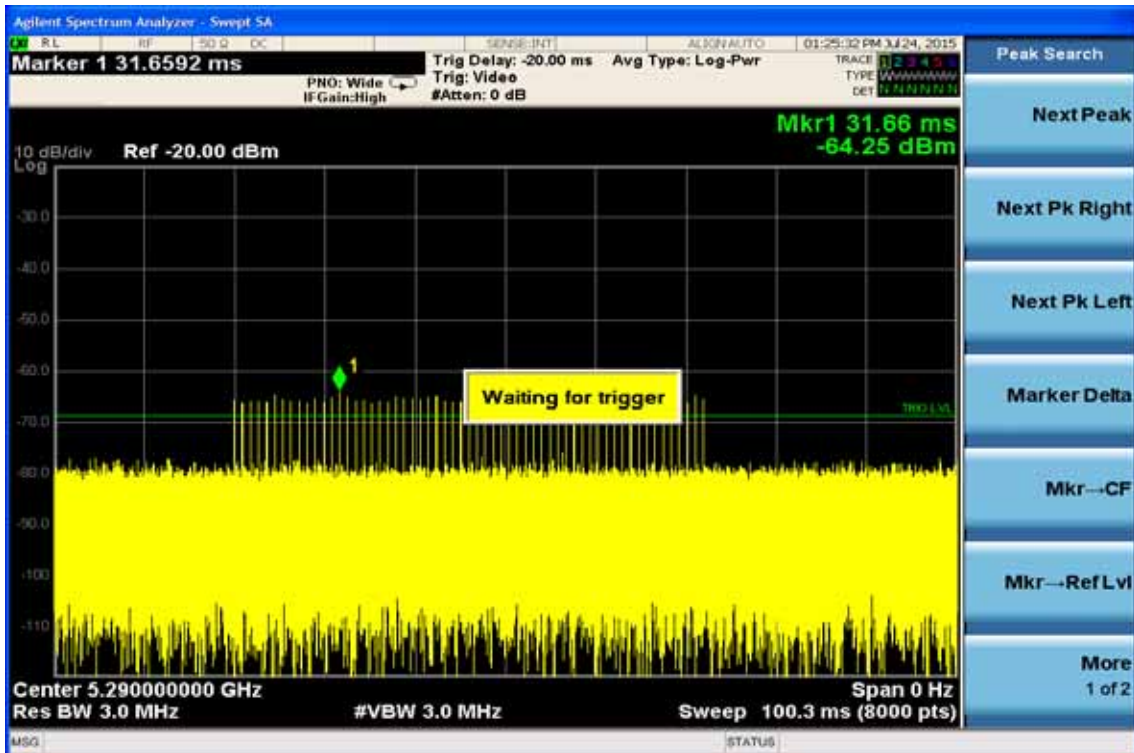

Radar type 1B

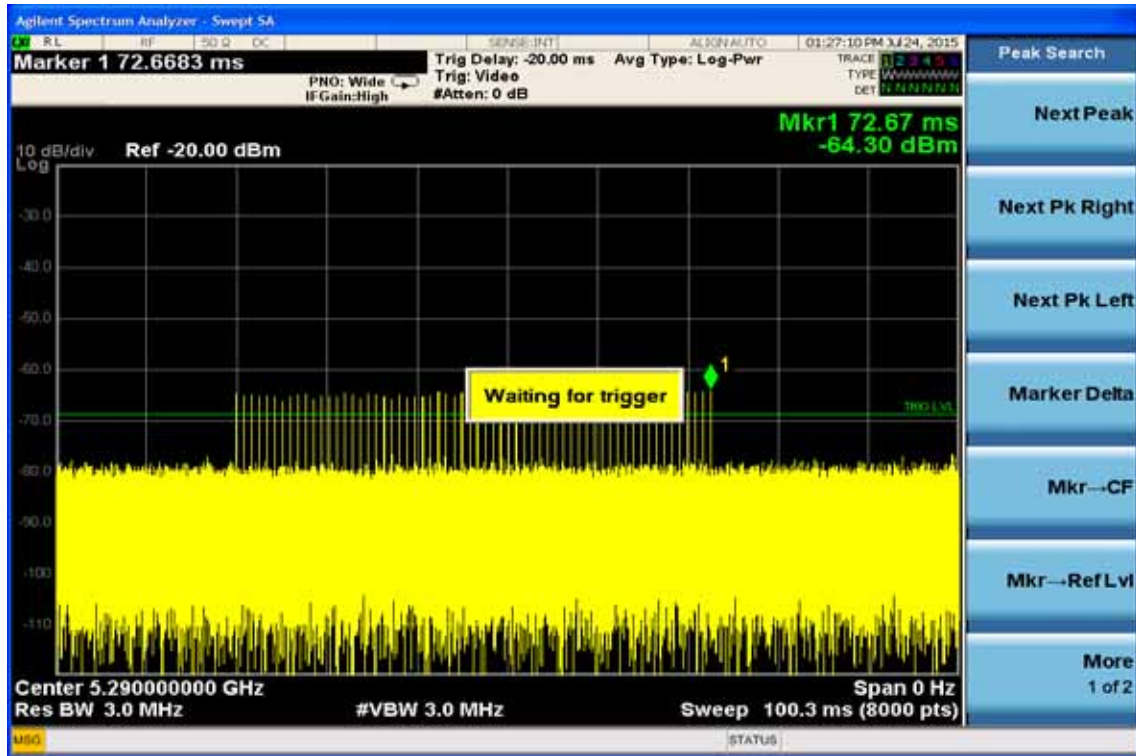

Radar type 2

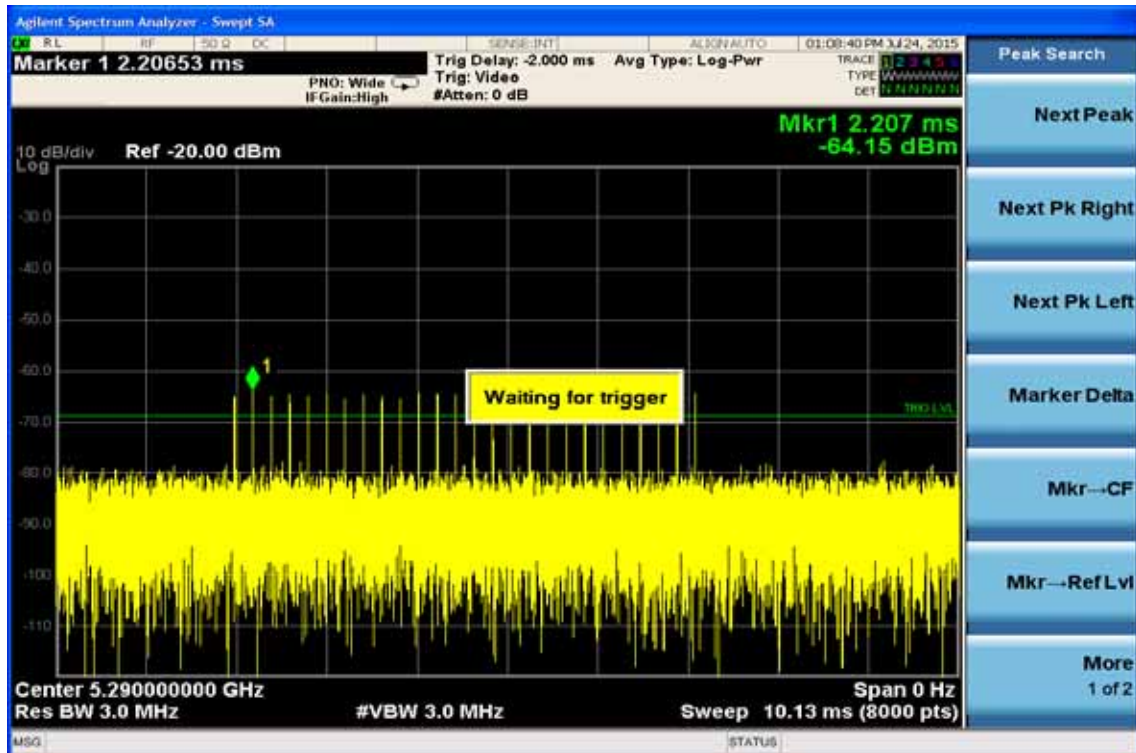

Radar type 3

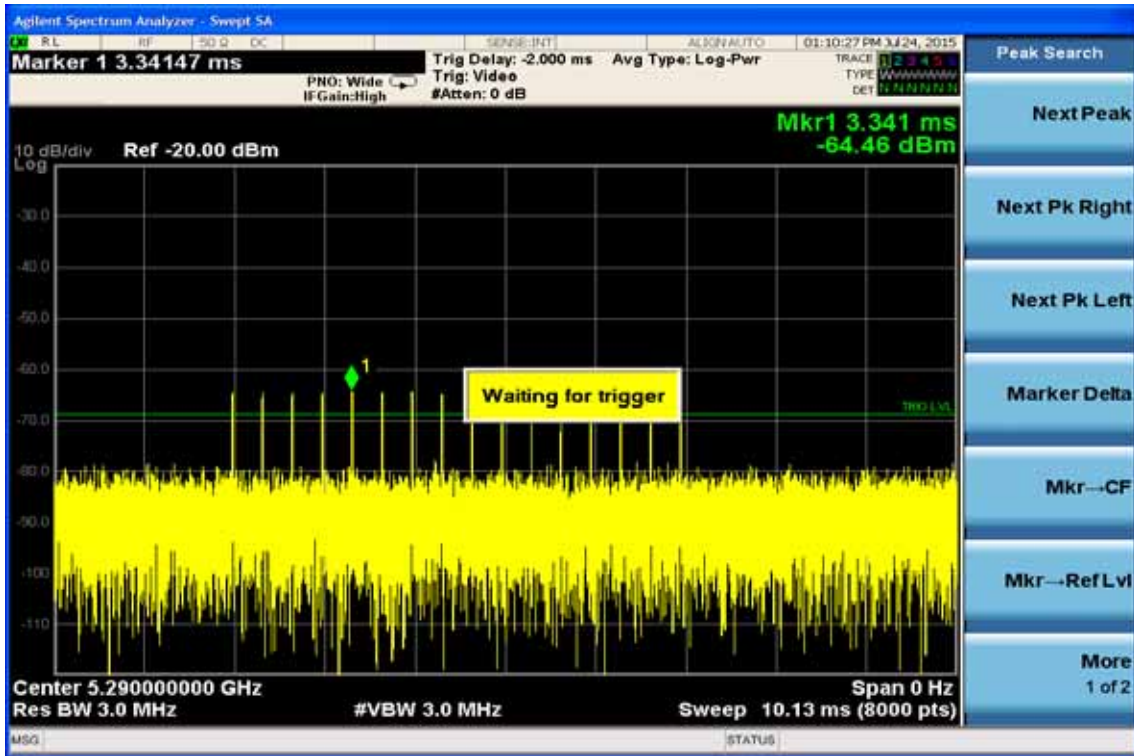

Radar type 4

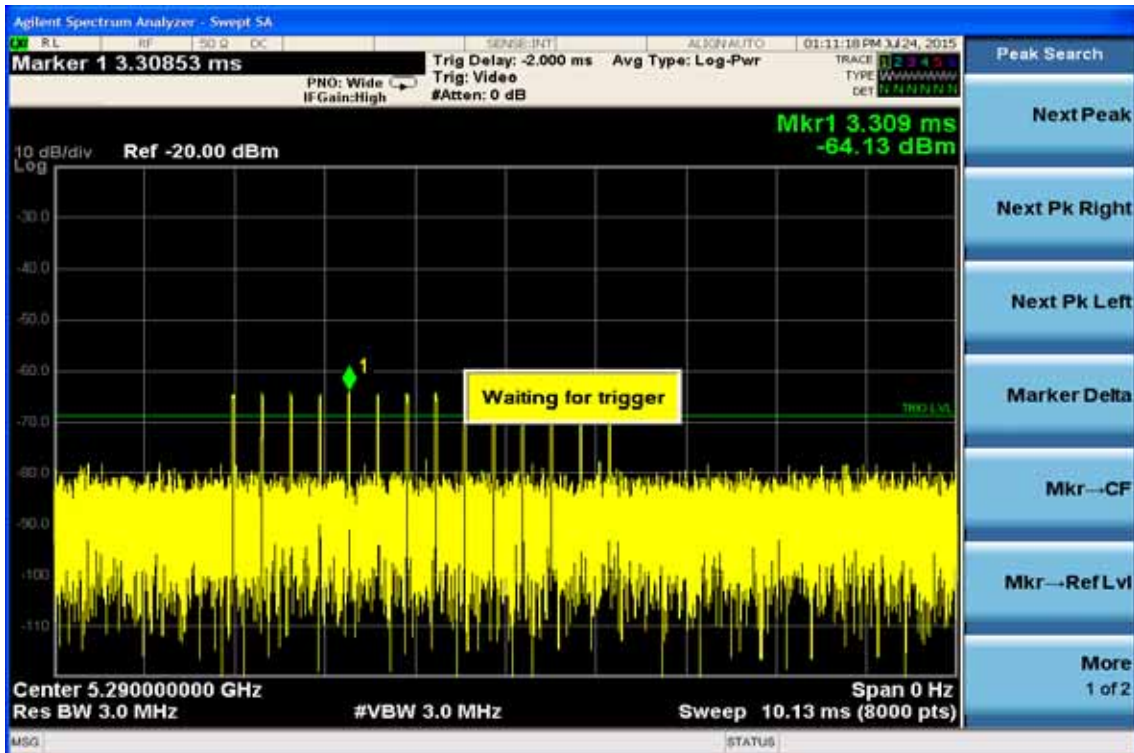

Radars type 5

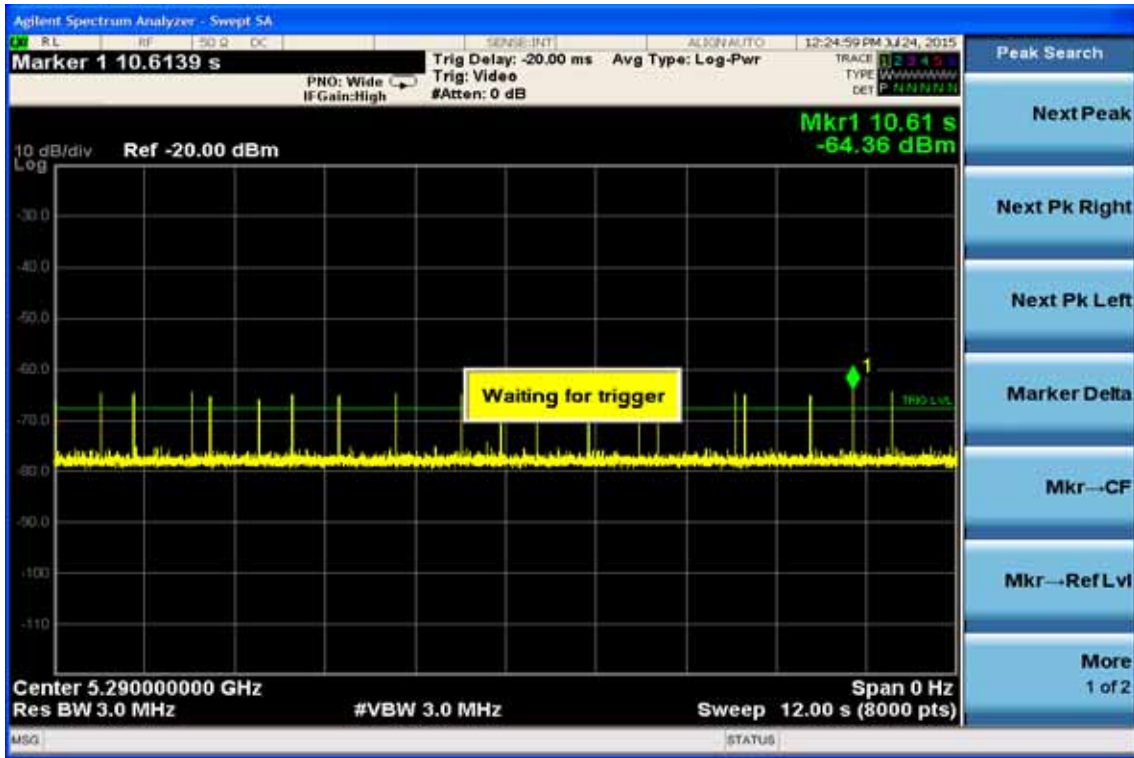

Radars type 6

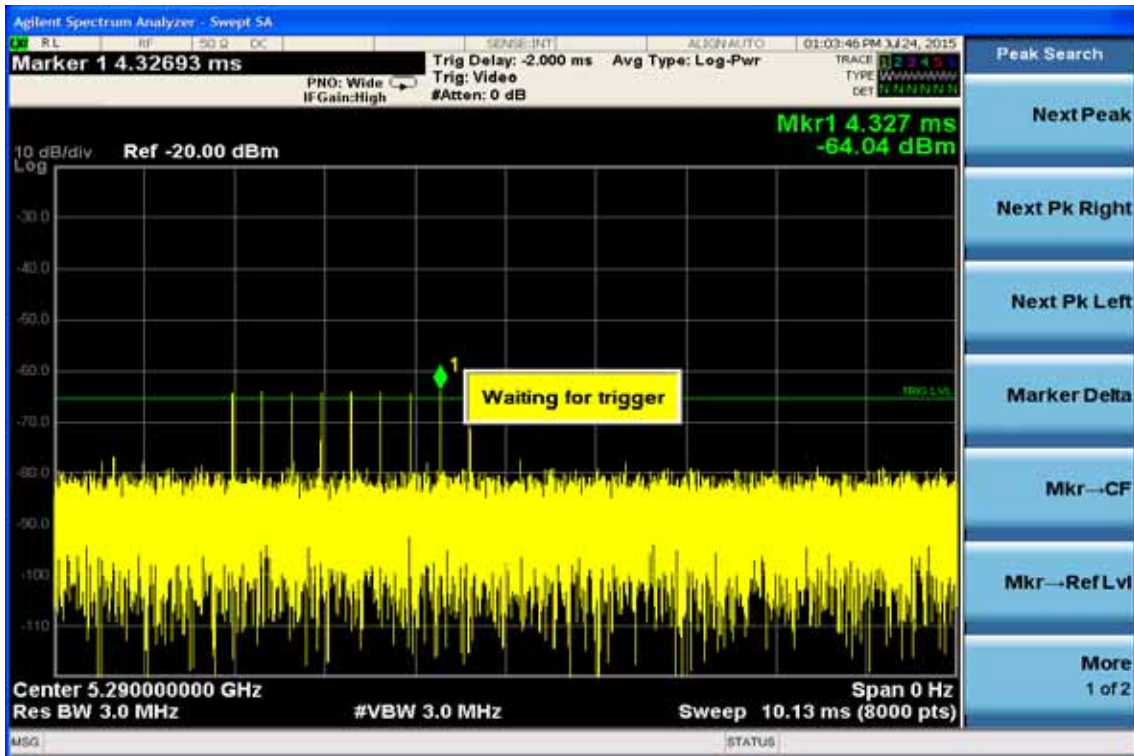

5470MHz ~ 5725MHz

Calibration plots for each of the required radar waveforms

Radar type 0

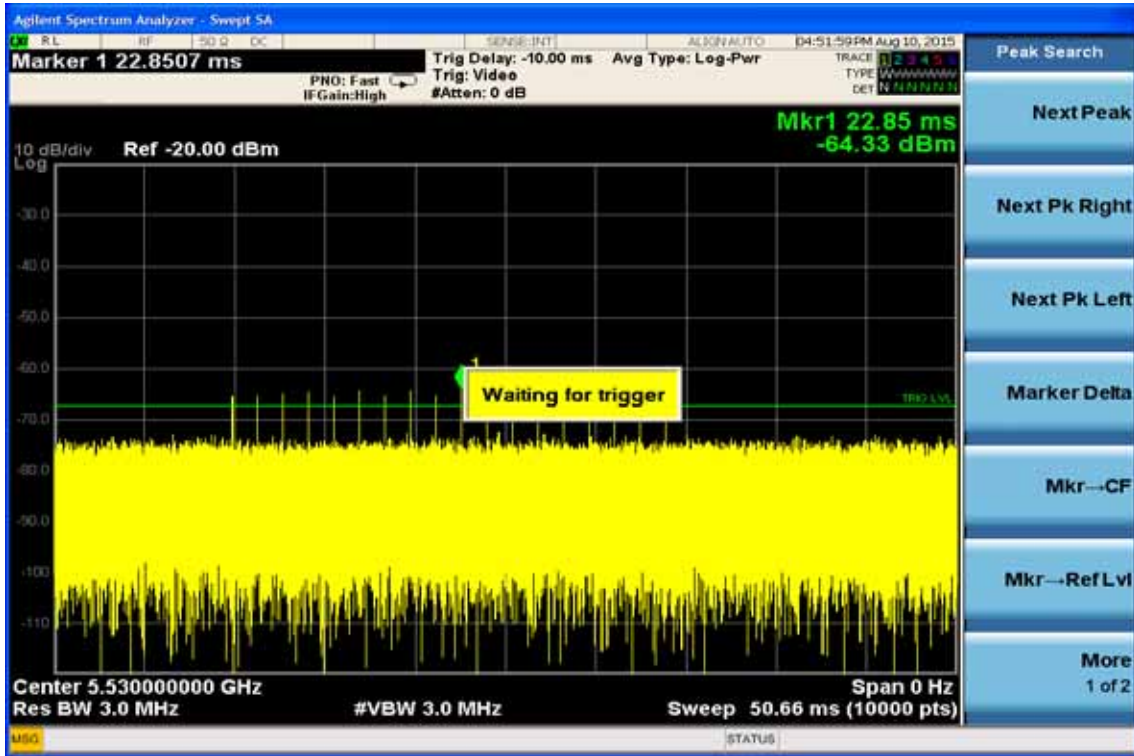

Radar type 1A

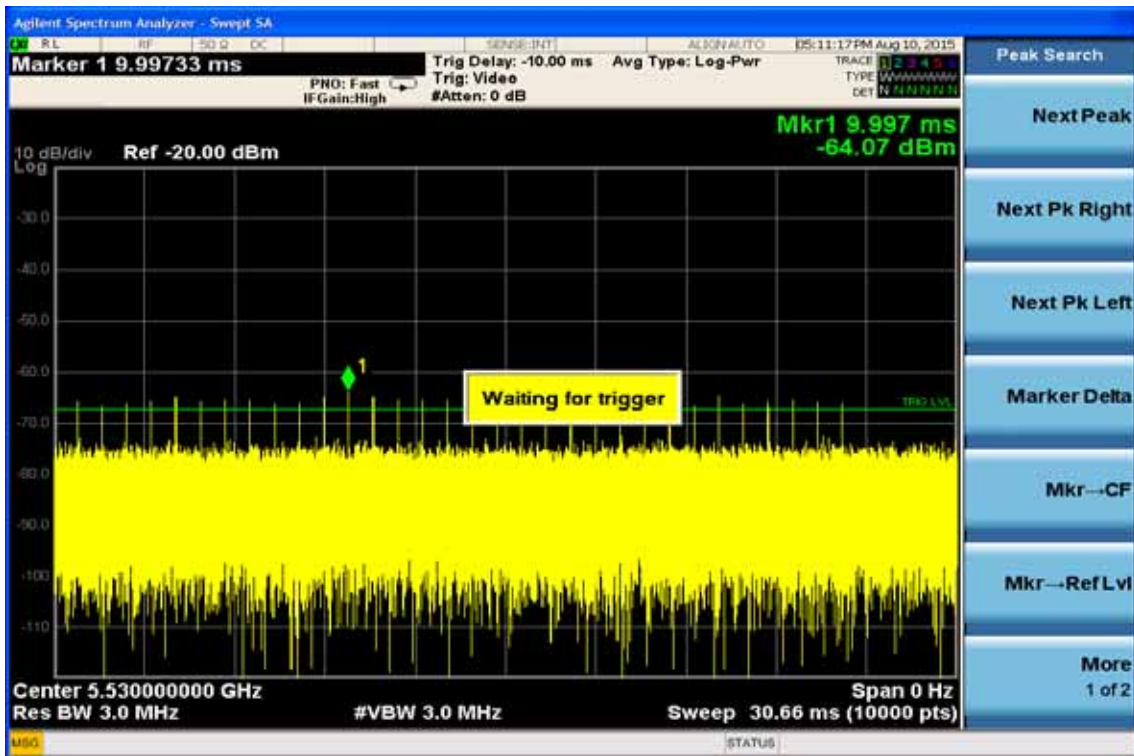

Radar type 1B

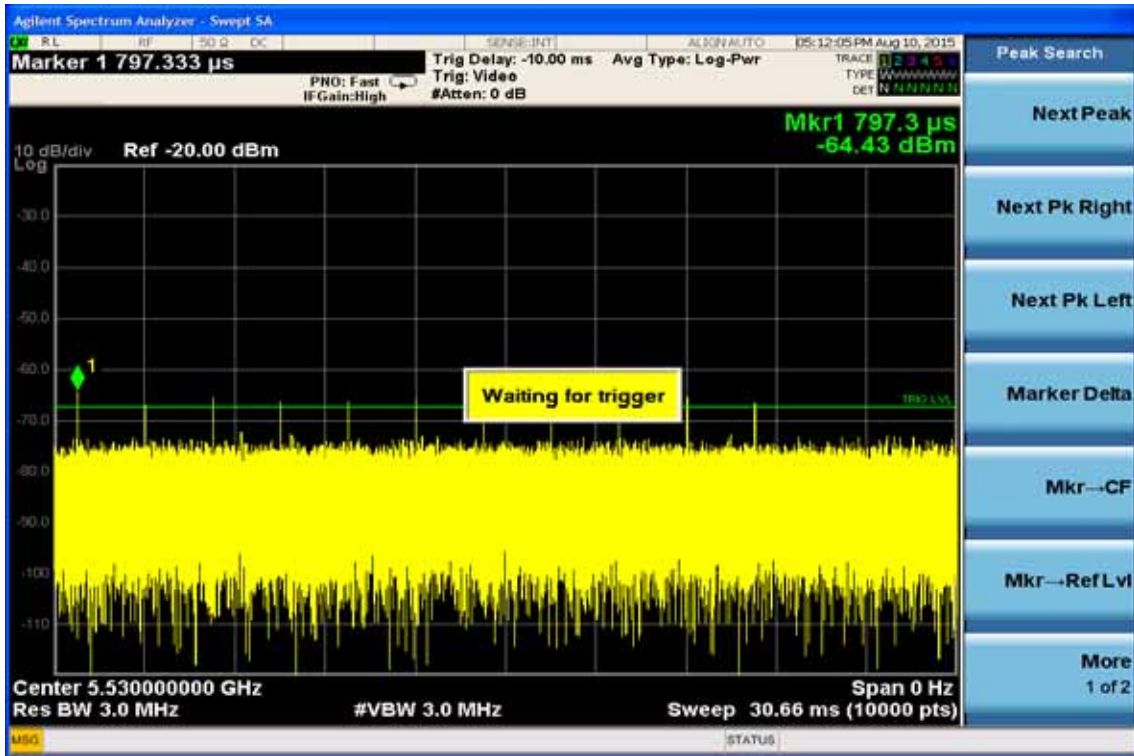

Radar type 2

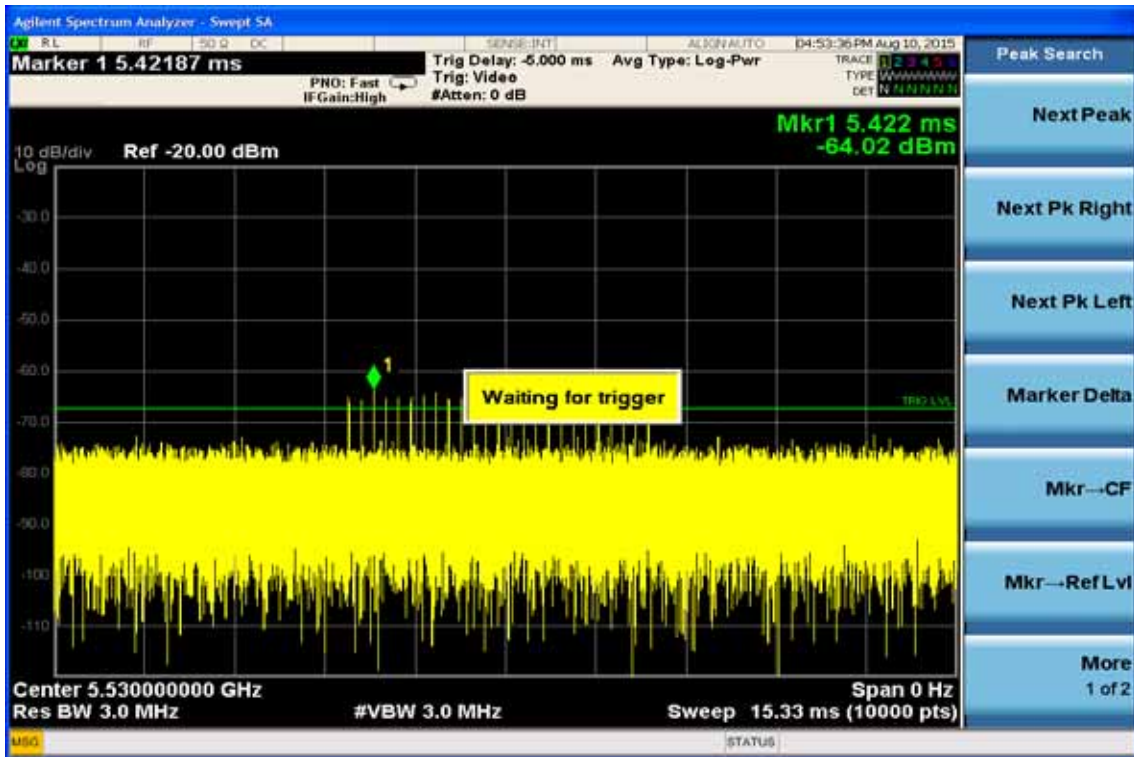

Radar type 3

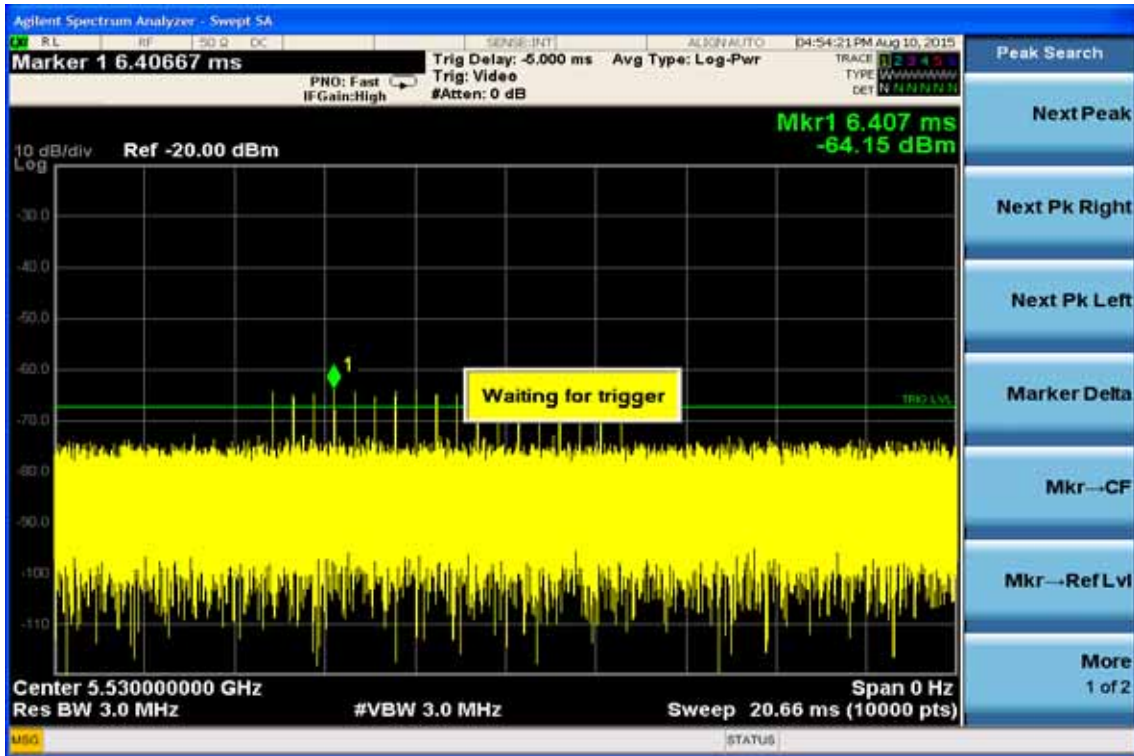

Radar type 4

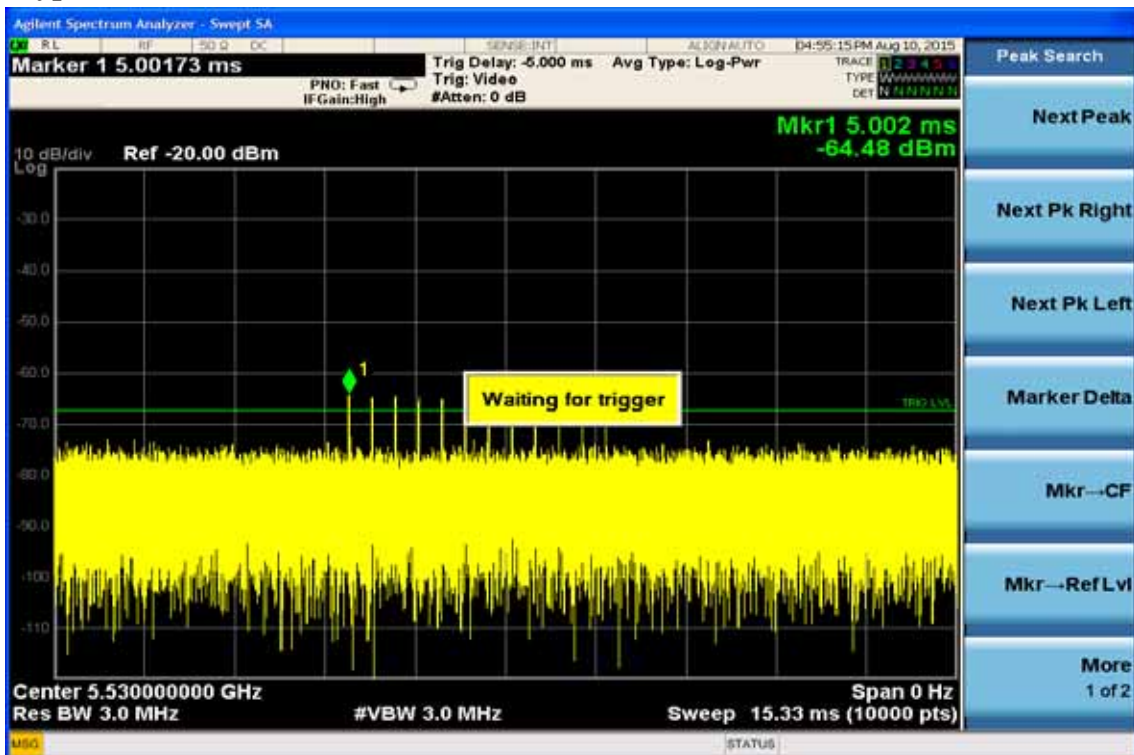

Radar type 5



Radar type 6

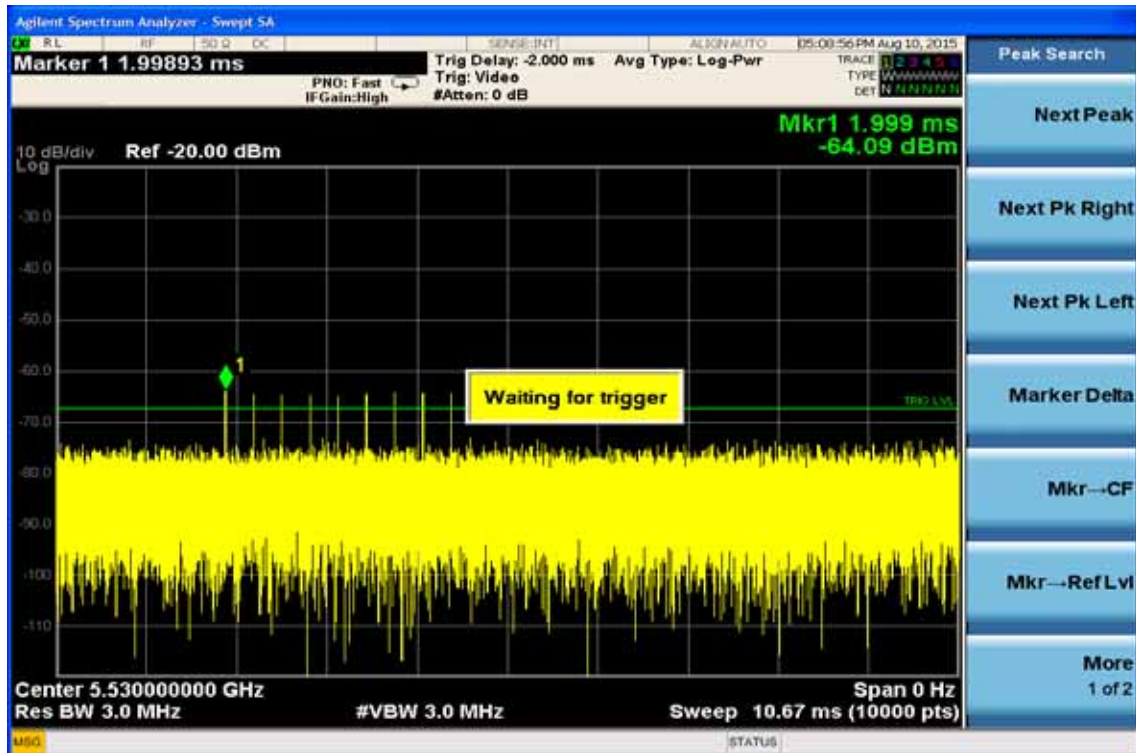

Pulse width

Plus wide 0

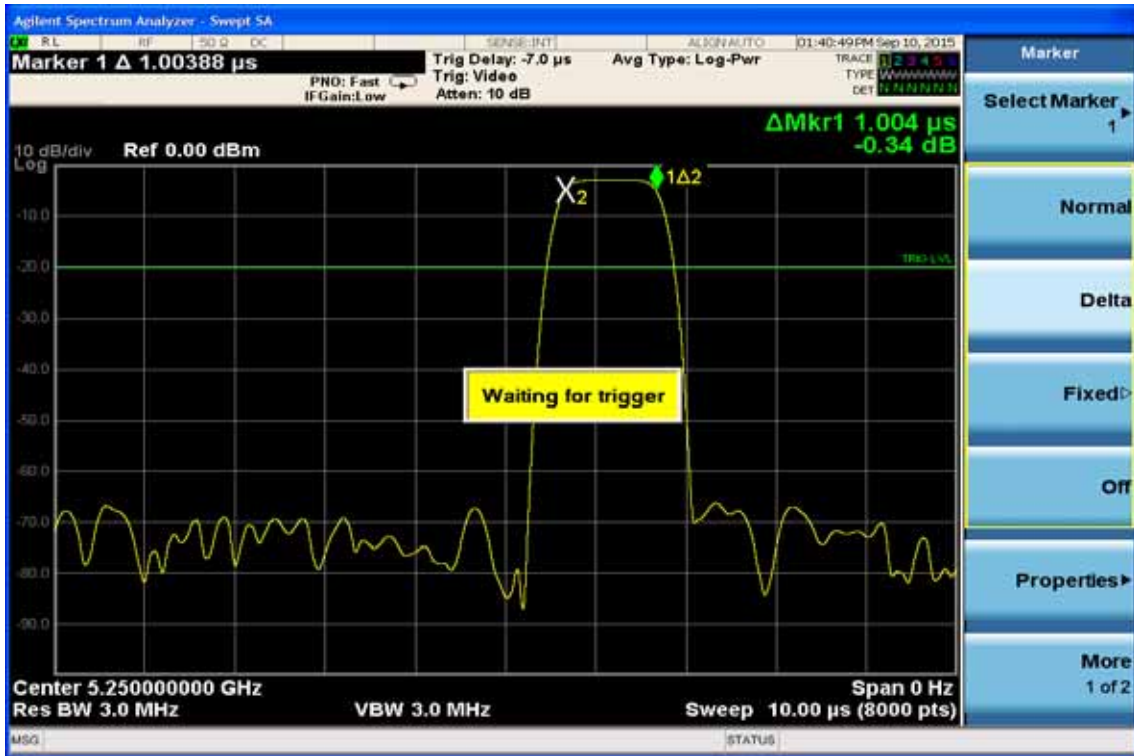

Plus wide 1a

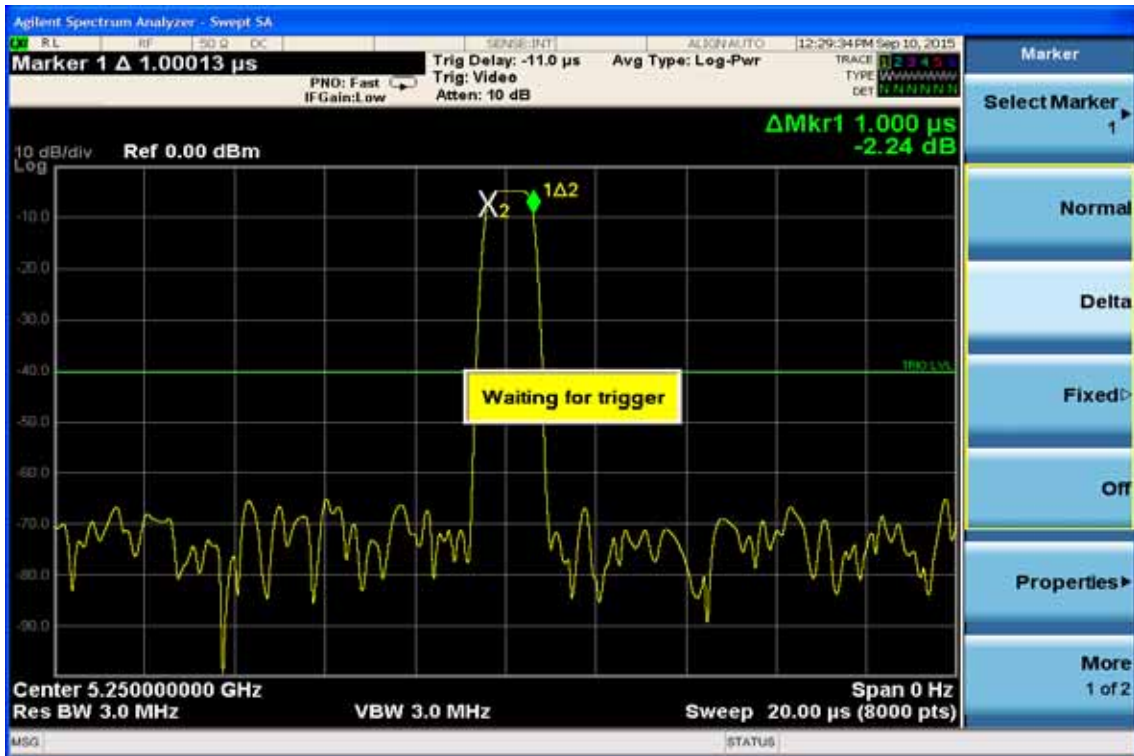

Plus wide 1b

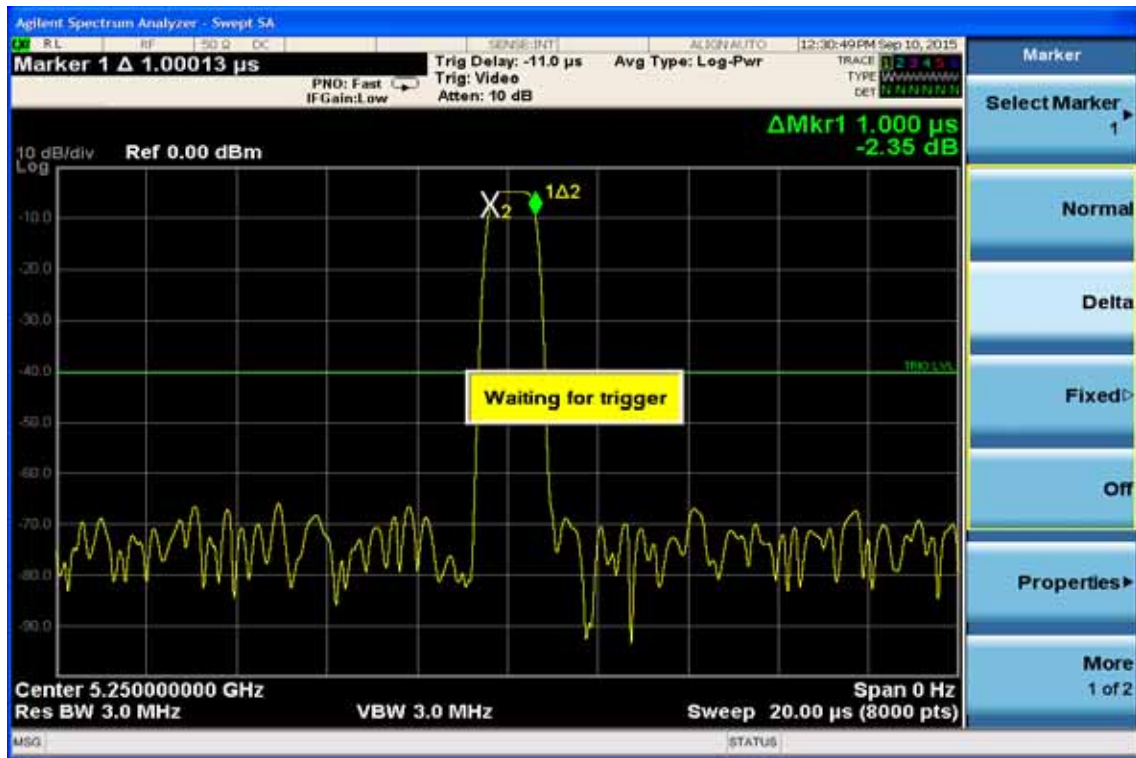

Plus wide 2

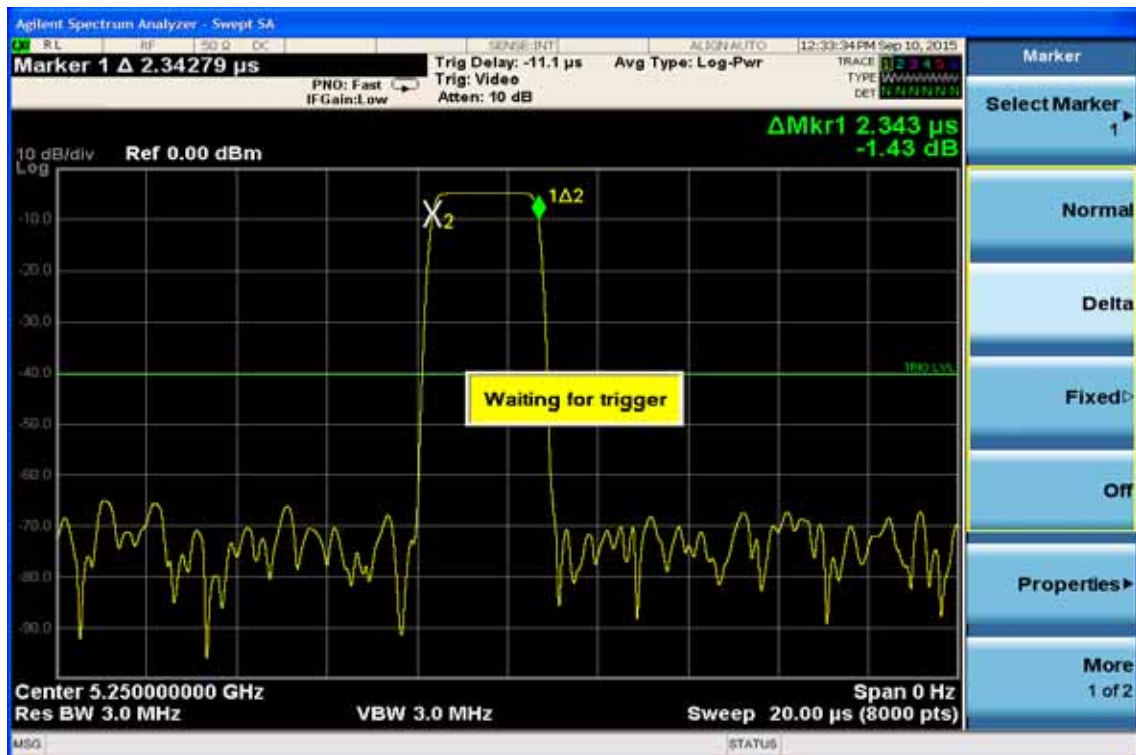

Plus wide 3

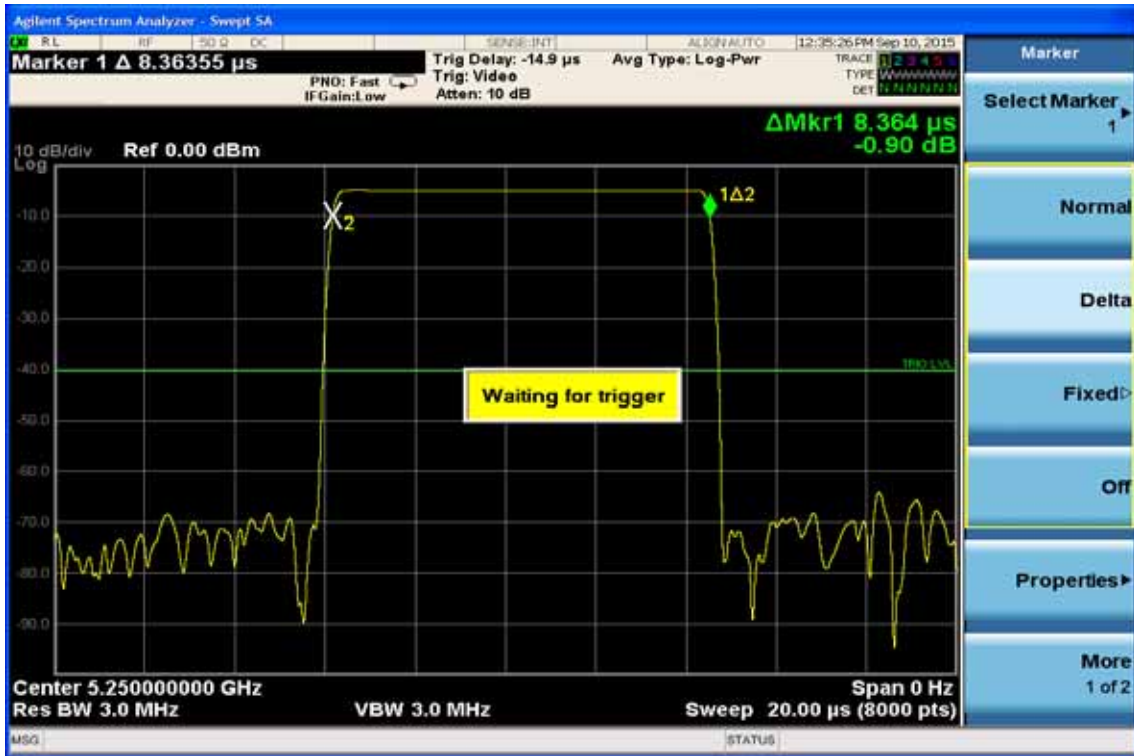

Plus wide 4

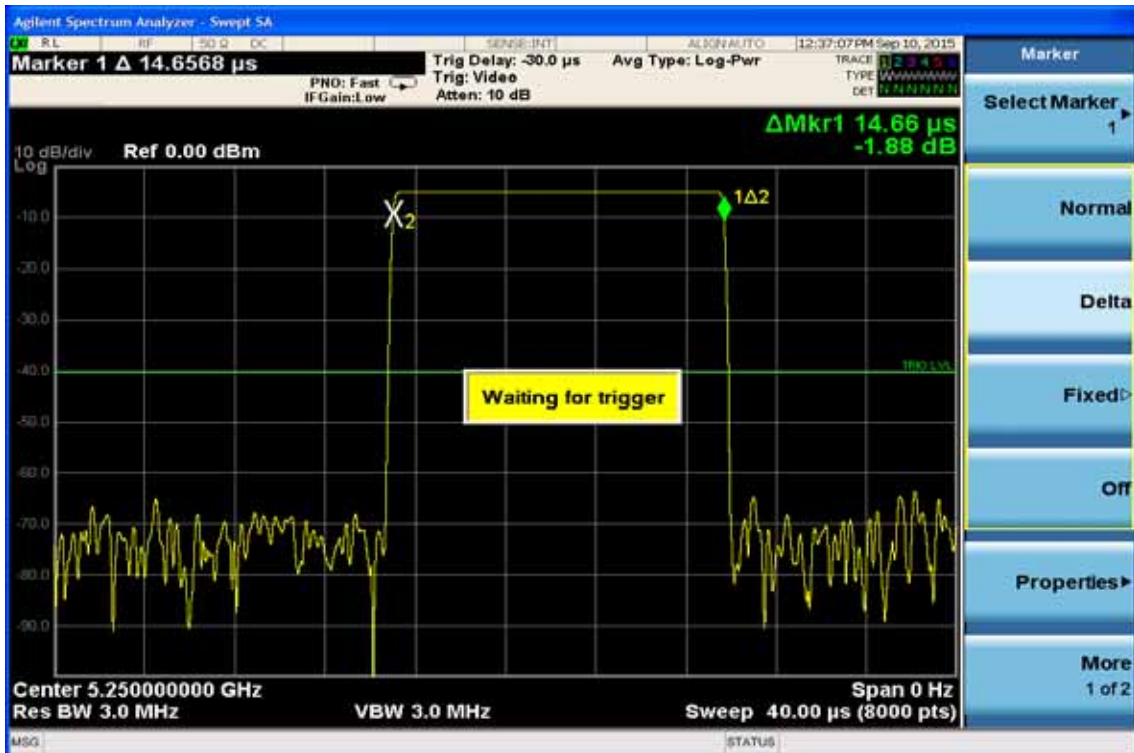

Plus wide 5

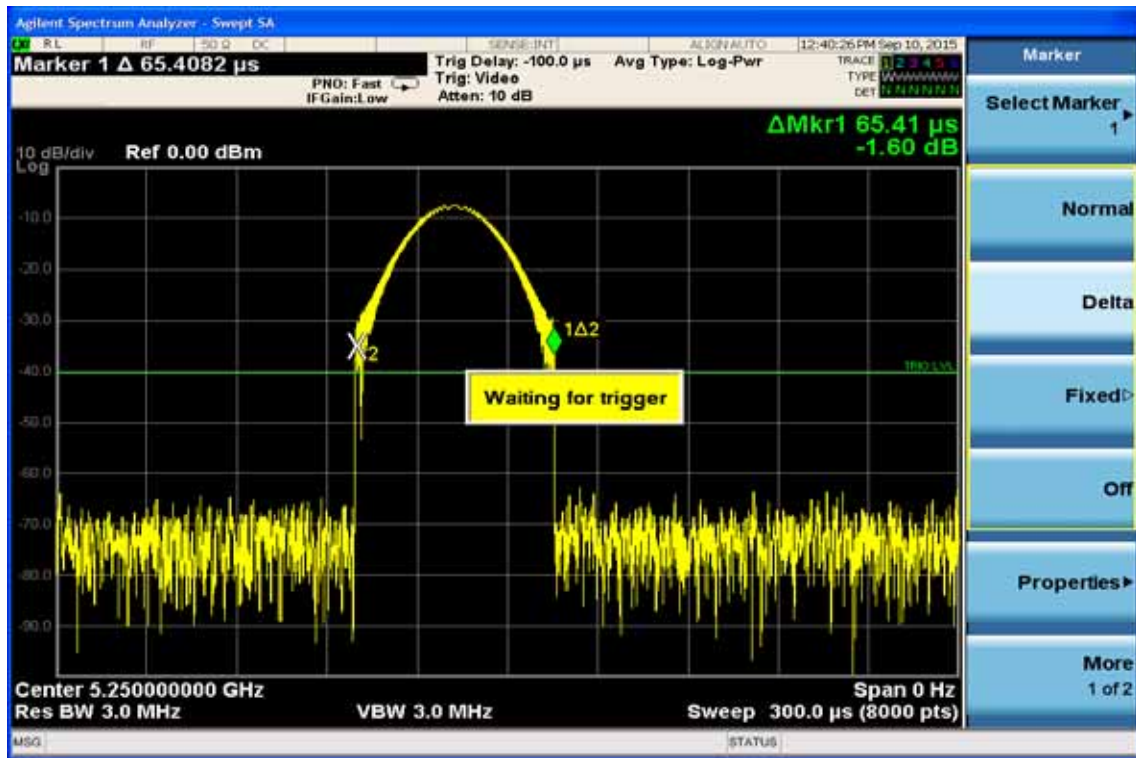

Plus wide 6

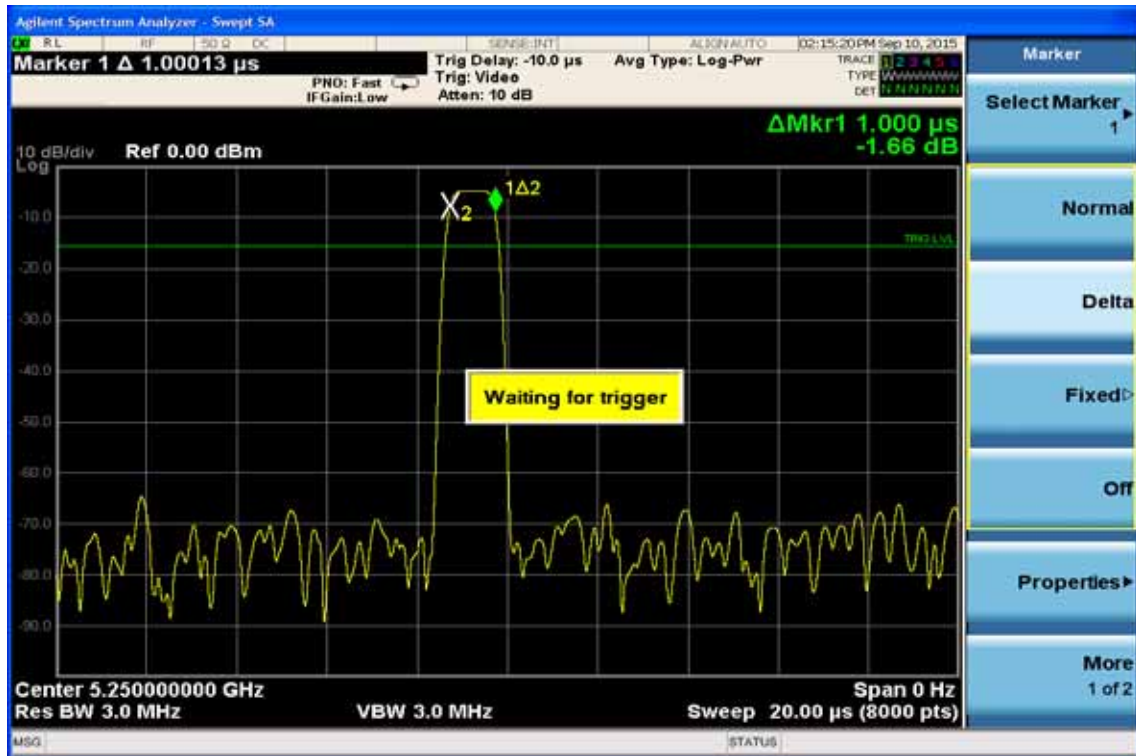

Radar information

Type o		
DFS waveform parameters (Radar Type 1)		
Pulse Width(us)	Pri(us)	Pulses/Burst
1	1428	18
Type 1A		
Random DFS waveform parameters (Radar Type 1)09-09-2015 16:14:05		
Pulse Width(us)	Pri(us)	Pulses/Burst
1	678	78
Type 1b		
Random DFS waveform parameters (Radar Type 1)09-09-2015 16:16:08		
Pulse Width(us)	Pri(us)	Pulses/Burst
1	1968	27
Type 2		
Random DFS waveform parameters (Radar Type 2)09-09-2015 16:17:05		
Pulse Width(us)	Pri(us)	Pulses/Burst
2.9	155	27
Type 3		
Random DFS waveform parameters (Radar Type 3)09-09-2015 16:17:57		
Pulse Width(us)	Pri(us)	Pulses/Burst
9.400001	358	16
Type 4		
Random DFS waveform parameters (Radar Type 4)09-09-2015 16:18:33		
Pulse Width(us)	Pri(us)	Pulses/Burst
11.9	367	12

Type 5

Waveform Num = 1
Num of Bursts = 17
Burst Interval (us)= 705882

Burst Start Loc # (us)	Off Time Start Burst (us) Interval(us)	# End Burst Pulses Interval(us)	Chirp (MHz)	PW (us)	Pulse 1 Pri(us)	Pulse 2 Pri(us)	Pulse 3 Pri(us)
1 604136	0 604136	1 705881	18	100	1967	0	0
2 714701	108598 705882 963144	2 1411763	19	60	1786	1831	0
3 1681462	1411764 708810	1 2117645	10	50	1255	0	0
4 2391527	2117646 902419	2 2823527	14	100	1503	1911	0
5 3297360	2823528 510615	1 3529409	9	60	1932	0	0
6 3809907	3529410 925239	1 4235291	15	100	1685	0	0
7 4736831	4235292 823026	2 4941173	8	90	1800	1745	0
8 5563402	4941174 503830	3 5647055	6	65	1823	1530	1172
9 6071757	5647056 560909	1 6352937	9	60	1115	0	0
10 6633781	6352938 778278	3 7058819	10	95	1897	1355	1307
11 7416618	7058820 453968	2 7764701	16	65	1165	1720	0
12 7873471	7764702 1016215	2 8470583	13	90	1199	1875	0
13 8892760	8470584 382874	2 9176465	20	85	1131	1047	0
14 9277812	9176466 725603	3 9882347	19	95	1035	1138	1790
15 10007378	9882348 1124604	2 10588229	11	80	1663	1894	0
16 11135539	10588230 409908	1 11294111	5	95	1422	0	0
17 11546869	11294112	2 11999993	17	70	1430	1222	0

Total number of pulses in waveform = 31

Type 5 Segments

Waveform Num = 1

Num of Bursts = 17

Burst Interval (us)= 705882

Segment #	Since Seg 1(us)	Between Seg(us)
1	0	0
2	110565	110565
3	112351	1786
4	1077326	964975
5	1787391	710065
6	1788894	1503
7	2693224	904330
8	3205771	512547
9	4132695	926924
10	4134495	1800
11	4959266	824771
12	4961089	1823
13	4962619	1530
14	5467621	505002
15	6029645	562024
16	6031542	1897
17	6032897	1355
18	6812482	779585
19	6813647	1165
20	7269335	455688
21	7270534	1199
22	8288624	1018090
23	8289755	1131
24	8673676	383921
25	8674711	1035
26	8675849	1138
27	9403242	727393
28	9404905	1663
29	10531403	1126498
30	10942733	411330
31	10944163	1430

Type 5 Segments

Waveform Num = 1

Num of Bursts = 17

Burst Interval (us)= 705882

Segment #	Since Seg 1(us)	Between Seg(us)
1	0	0
2	110565	110565
3	112351	1786
4	1077326	964975
5	1787391	710065
6	1788894	1503
7	2693224	904330
8	3205771	512547
9	4132695	926924
10	4134495	1800
11	4959266	824771
12	4961089	1823
13	4962619	1530
14	5467621	505002
15	6029645	562024
16	6031542	1897
17	6032897	1355
18	6812482	779585
19	6813647	1165
20	7269335	455688
21	7270534	1199
22	8288624	1018090
23	8289755	1131
24	8673676	383921
25	8674711	1035
26	8675849	1138
27	9403242	727393
28	9404905	1663
29	10531403	1126498
30	10942733	411330
31	10944163	1430

Type 6

Random DFS waveform parameters (Radar Type 6)

RLAN Freq Range:

Trail#	HopFreq List#	HopFreq	In WLAN BW(80M)	Hopping Rate(kHz)	Hopping Length(ms)
1	0	5305	No	0.333	300
1	1	5653	No	0.333	300
1	2	5472	No	0.333	300
1	3	5302	No	0.333	300
1	4	5723	No	0.333	300
1	5	5701	No	0.333	300
1	6	5437	No	0.333	300
1	7	5434	No	0.333	300
1	8	5516	No	0.333	300
1	9	5391	No	0.333	300
1	10	5517	No	0.333	300
1	11	5286	No	0.333	300
1	12	5515	No	0.333	300
1	13	5315	No	0.333	300
1	14	5386	No	0.333	300
1	15	5686	No	0.333	300
1	16	5274	***Yes***	0.333	300

1	17	5401	No	0.333	300
1	18	5374	No	0.333	300
1	19	5379	No	0.333	300
1	20	5666	No	0.333	300
1	21	5322	No	0.333	300
1	22	5629	No	0.333	300
1	23	5637	No	0.333	300
1	24	5414	No	0.333	300
1	25	5710	No	0.333	300
1	26	5387	No	0.333	300
1	27	5565	No	0.333	300
1	28	5679	No	0.333	300
1	29	5604	No	0.333	300
1	30	5416	No	0.333	300
1	31	5690	No	0.333	300
1	32	5436	No	0.333	300
1	33	5618	No	0.333	300
1	34	5441	No	0.333	300
1	35	5506	No	0.333	300

1	36	5298	No	0.333	300
1	37	5325	No	0.333	300
1	38	5644	No	0.333	300
1	39	5364	No	0.333	300
1	40	5277	***Yes***	0.333	300
1	41	5372	No	0.333	300
1	42	5501	No	0.333	300
1	43	5619	No	0.333	300
1	44	5545	No	0.333	300
1	45	5600	No	0.333	300
1	46	5628	No	0.333	300
1	47	5435	No	0.333	300
1	48	5254	***Yes***	0.333	300
1	49	5376	No	0.333	300
1	50	5638	No	0.333	300
1	51	5570	No	0.333	300
1	52	5289	No	0.333	300
1	53	5712	No	0.333	300
1	54	5421	No	0.333	300
1	55	5714	No	0.333	300

1	56	5458	No	0.333	300
1	57	5308	No	0.333	300
1	58	5290	No	0.333	300
1	59	5412	No	0.333	300
1	60	5498	No	0.333	300
1	61	5718	No	0.333	300
1	62	5684	No	0.333	300
1	63	5300	No	0.333	300
1	64	5403	No	0.333	300
1	65	5490	No	0.333	300
1	66	5301	No	0.333	300
1	67	5697	No	0.333	300
1	68	5265	***Yes***	0.333	300
1	69	5321	No	0.333	300
1	70	5311	No	0.333	300
1	71	5716	No	0.333	300
1	72	5518	No	0.333	300
1	73	5293	No	0.333	300
1	74	5291	No	0.333	300

1	75	5562	No	0.333	300
1	76	5543	No	0.333	300
1	77	5282	No	0.333	300
1	78	5396	No	0.333	300
1	79	5480	No	0.333	300
1	80	5292	No	0.333	300
1	81	5450	No	0.333	300
1	82	5652	No	0.333	300
1	83	5263	***Yes***	0.333	300
1	84	5407	No	0.333	300
1	85	5681	No	0.333	300
1	86	5475	No	0.333	300
1	87	5661	No	0.333	300
1	88	5404	No	0.333	300
1	89	5496	No	0.333	300
1	90	5514	No	0.333	300
1	91	5250	***Yes***	0.333	300
1	92	5476	No	0.333	300
1	93	5576	No	0.333	300
1	94	5405	No	0.333	300

1	95	5445	No	0.333	300
1	96	5560	No	0.333	300
1	97	5529	No	0.333	300
1	98	5343	No	0.333	300
1	99	5397	No	0.333	300

Detection BW

For 20MHz BW 5250-5350 Test TYPE Type 0 only
 center Frequency : 5260
 99% BW : 17.56
 Detection range: F low= 5251.22 F high= 5268.78
 DFS Detection Trials

Frequency	1	2	3	4	5	6	7	8	9	10	Limit
5251	Y	Y	Y	Y	Y	Y	Y	Y	Y	Y	90%
5252	Y	Y	Y	Y	Y	Y	Y	Y	Y	Y	90%
5253	Y	Y	Y	Y	Y	Y	Y	Y	Y	Y	90%
5254	Y	Y	Y	Y	Y	Y	Y	Y	Y	Y	90%
5255	Y	Y	Y	Y	Y	Y	Y	Y	Y	Y	90%
5256	Y	Y	Y	Y	Y	Y	Y	Y	Y	Y	90%
5257	Y	Y	Y	Y	Y	Y	Y	Y	Y	Y	90%
5258	Y	Y	Y	Y	Y	Y	Y	Y	Y	Y	90%
5259	Y	Y	Y	Y	Y	Y	Y	Y	Y	Y	90%
5260	Y	Y	Y	Y	Y	Y	Y	Y	Y	Y	90%
5261	Y	Y	Y	Y	Y	Y	Y	Y	Y	Y	90%
5262	Y	Y	Y	Y	Y	Y	Y	Y	Y	Y	90%
5263	Y	Y	Y	Y	Y	Y	Y	Y	Y	Y	90%
5264	Y	Y	Y	Y	Y	Y	Y	Y	Y	Y	90%
5265	Y	Y	Y	Y	Y	Y	Y	Y	Y	Y	90%
5266	Y	Y	Y	Y	Y	Y	Y	Y	Y	Y	90%
5267	Y	Y	Y	Y	Y	Y	Y	Y	Y	Y	90%
5268	Y	Y	Y	Y	Y	Y	Y	Y	Y	Y	90%
5269	Y	Y	Y	Y	Y	Y	Y	Y	Y	Y	90%

Result: Pass: 100%

For 20MHz BW 5470-5725

center Frequency : 5500

99% BW : 17.59

Detection range: F low= 5491.205 F high= 5508.795

DFS Detection Trials

Frequency	1	2	3	4	5	6	7	8	9	10	Limit
5491	Y	Y	Y	Y	Y	Y	Y	Y	Y	Y	90%
5492	Y	Y	Y	Y	Y	Y	Y	Y	Y	Y	90%
5493	Y	Y	Y	Y	Y	Y	Y	Y	Y	Y	90%
5494	Y	Y	Y	Y	Y	Y	Y	Y	Y	Y	90%
5495	Y	Y	Y	Y	Y	Y	Y	Y	Y	Y	90%
5496	Y	Y	Y	Y	Y	Y	Y	Y	Y	Y	90%
5497	Y	Y	Y	Y	Y	Y	Y	Y	Y	Y	90%
5498	Y	Y	Y	Y	Y	Y	Y	Y	Y	Y	90%
5499	Y	Y	Y	Y	Y	Y	Y	Y	Y	Y	90%
5500	Y	Y	Y	Y	Y	Y	Y	Y	Y	Y	90%
5501	Y	Y	Y	Y	Y	Y	Y	Y	Y	Y	90%
5502	Y	Y	Y	Y	Y	Y	Y	Y	Y	Y	90%
5503	Y	Y	Y	Y	Y	Y	Y	Y	Y	Y	90%
5504	Y	Y	Y	Y	Y	Y	Y	Y	Y	Y	90%
5505	Y	Y	Y	Y	Y	Y	Y	Y	Y	Y	90%
5506	Y	Y	Y	Y	Y	Y	Y	Y	Y	Y	90%
5507	Y	Y	Y	Y	Y	Y	Y	Y	Y	Y	90%
5508	Y	Y	Y	Y	Y	Y	Y	Y	Y	Y	90%
5509	Y	Y	Y	Y	Y	Y	Y	Y	Y	Y	90%

Result: Pass: 100%

For 40MHz BW

center Frequency : 5270

99% BW : 37.029

Detection range: F low= 5251.486 F high= 5288.515

DFS Detection Trials

Frequency	1	2	3	4	5	6	7	8	9	10	Limit
5251	Y	Y	Y	Y	Y	Y	Y	Y	Y	Y	90%
5252	Y	Y	Y	Y	Y	Y	Y	Y	Y	Y	90%
5253	Y	Y	Y	Y	Y	Y	Y	Y	Y	Y	90%
5254	Y	Y	Y	Y	Y	Y	Y	Y	Y	Y	90%
5255	Y	Y	Y	Y	Y	Y	Y	Y	Y	Y	90%
5256	Y	Y	Y	Y	Y	Y	Y	Y	Y	Y	90%
5257	Y	Y	Y	Y	Y	Y	Y	Y	Y	Y	90%
5258	Y	Y	Y	Y	Y	Y	Y	Y	Y	Y	90%
5259	Y	Y	Y	Y	Y	Y	Y	Y	Y	Y	90%
5260	Y	Y	Y	Y	Y	Y	Y	Y	Y	Y	90%
5261	Y	Y	Y	Y	Y	Y	Y	Y	Y	Y	90%
5262	Y	Y	Y	Y	Y	Y	Y	Y	Y	Y	90%
5263	Y	Y	Y	Y	Y	Y	Y	Y	Y	Y	90%
5264	Y	Y	Y	Y	Y	Y	Y	Y	Y	Y	90%
5265	Y	Y	Y	Y	Y	Y	Y	Y	Y	Y	90%
5266	Y	Y	Y	Y	Y	Y	Y	Y	Y	Y	90%
5267	Y	Y	Y	Y	Y	Y	Y	Y	Y	Y	90%
5268	Y	Y	Y	Y	Y	Y	Y	Y	Y	Y	90%
5269	Y	Y	Y	Y	Y	Y	Y	Y	Y	Y	90%
5270	Y	Y	Y	Y	Y	Y	Y	Y	Y	Y	90%
5271	Y	Y	Y	Y	Y	Y	Y	Y	Y	Y	90%
5272	Y	Y	Y	Y	Y	Y	Y	Y	Y	Y	90%
5273	Y	Y	Y	Y	Y	Y	Y	Y	Y	Y	90%
5274	Y	Y	Y	Y	Y	Y	Y	Y	Y	Y	90%
5275	Y	Y	Y	Y	Y	Y	Y	Y	Y	Y	90%
5276	Y	Y	Y	Y	Y	Y	Y	Y	Y	Y	90%
5277	Y	Y	Y	Y	Y	Y	Y	Y	Y	Y	90%
5278	Y	Y	Y	Y	Y	Y	Y	Y	Y	Y	90%
5279	Y	Y	Y	Y	Y	Y	Y	Y	Y	Y	90%
5280	Y	Y	Y	Y	Y	Y	Y	Y	Y	Y	90%
5281	Y	Y	Y	Y	Y	Y	Y	Y	Y	Y	90%
5282	Y	Y	Y	Y	Y	Y	Y	Y	Y	Y	90%
5283	Y	Y	Y	Y	Y	Y	Y	Y	Y	Y	90%
5284	Y	Y	Y	Y	Y	Y	Y	Y	Y	Y	90%

5285	Y	Y	Y	Y	Y	Y	Y	Y	Y	Y	90%
5286	Y	Y	Y	Y	Y	Y	Y	Y	Y	Y	90%
5287	Y	Y	Y	Y	Y	Y	Y	Y	Y	Y	90%
5288	Y	Y	Y	Y	Y	Y	Y	Y	Y	Y	90%
5289	Y	Y	Y	Y	Y	Y	Y	Y	Y	Y	90%

Result: Pass: 100%

For 40MHz BW

center Frequency : 5510

99% BW : 36.94

Detection range: F low= 5491.53 F high= 5528.47

DFS Detection Trials

Frequency	1	2	3	4	5	6	7	8	9	10	Limit
5491	Y	Y	Y	Y	Y	Y	Y	Y	Y	Y	90%
5492	Y	Y	Y	Y	Y	Y	Y	Y	Y	Y	90%
5493	Y	Y	Y	Y	Y	Y	Y	Y	Y	Y	90%
5494	Y	Y	Y	Y	Y	Y	Y	Y	Y	Y	90%
5495	Y	Y	Y	Y	Y	Y	Y	Y	Y	Y	90%
5496	Y	Y	Y	Y	Y	Y	Y	Y	Y	Y	90%
5497	Y	Y	Y	Y	Y	Y	Y	Y	Y	Y	90%
5498	Y	Y	Y	Y	Y	Y	Y	Y	Y	Y	90%
5499	Y	Y	Y	Y	Y	Y	Y	Y	Y	Y	90%
5500	Y	Y	Y	Y	Y	Y	Y	Y	Y	Y	90%
5501	Y	Y	Y	Y	Y	Y	Y	Y	Y	Y	90%
5502	Y	Y	Y	Y	Y	Y	Y	Y	Y	Y	90%
5503	Y	Y	Y	Y	Y	Y	Y	Y	Y	Y	90%
5504	Y	Y	Y	Y	Y	Y	Y	Y	Y	Y	90%
5505	Y	Y	Y	Y	Y	Y	Y	Y	Y	Y	90%
5506	Y	Y	Y	Y	Y	Y	Y	Y	Y	Y	90%
5507	Y	Y	Y	Y	Y	Y	Y	Y	Y	Y	90%
5508	Y	Y	Y	Y	Y	Y	Y	Y	Y	Y	90%
5509	Y	Y	Y	Y	Y	Y	Y	Y	Y	Y	90%
5510	Y	Y	Y	Y	Y	Y	Y	Y	Y	Y	90%
5511	Y	Y	Y	Y	Y	Y	Y	Y	Y	Y	90%
5512	Y	Y	Y	Y	Y	Y	Y	Y	Y	Y	90%
5513	Y	Y	Y	Y	Y	Y	Y	Y	Y	Y	90%
5514	Y	Y	Y	Y	Y	Y	Y	Y	Y	Y	90%
5515	Y	Y	Y	Y	Y	Y	Y	Y	Y	Y	90%
5516	Y	Y	Y	Y	Y	Y	Y	Y	Y	Y	90%
5517	Y	Y	Y	Y	Y	Y	Y	Y	Y	Y	90%
5518	Y	Y	Y	Y	Y	Y	Y	Y	Y	Y	90%
5519	Y	Y	Y	Y	Y	Y	Y	Y	Y	Y	90%
5520	Y	Y	Y	Y	Y	Y	Y	Y	Y	Y	90%
5521	Y	Y	Y	Y	Y	Y	Y	Y	Y	Y	90%
5522	Y	Y	Y	Y	Y	Y	Y	Y	Y	Y	90%
5523	Y	Y	Y	Y	Y	Y	Y	Y	Y	Y	90%
5524	Y	Y	Y	Y	Y	Y	Y	Y	Y	Y	90%

5525	Y	Y	Y	Y	Y	Y	Y	Y	Y	Y	90%
5526	Y	Y	Y	Y	Y	Y	Y	Y	Y	Y	90%
5527	Y	Y	Y	Y	Y	Y	Y	Y	Y	Y	90%
5528	Y	Y	Y	Y	Y	Y	Y	Y	Y	Y	90%
5529	Y	Y	Y	Y	Y	Y	Y	Y	Y	Y	90%

Result: Pass: 100%

For 80MHz BW

center Frequency : 5290

99% BW : 76.504

Detection range: F low= 5251.748 F high= 5328.252

DFS Detection Trials

Frequency	1	2	3	4	5	6	7	8	9	10	Limit
5251	Y	Y	Y	Y	Y	Y	Y	Y	Y	Y	90%
5252	Y	Y	Y	Y	Y	Y	Y	Y	Y	Y	90%
5253	Y	Y	Y	Y	Y	Y	Y	Y	Y	Y	90%
5254	Y	Y	Y	Y	Y	Y	Y	Y	Y	Y	90%
5255	Y	Y	Y	Y	Y	Y	Y	Y	Y	Y	90%
5256	Y	Y	Y	Y	Y	Y	Y	Y	Y	Y	90%
5257	Y	Y	Y	Y	Y	Y	Y	Y	Y	Y	90%
5258	Y	Y	Y	Y	Y	Y	Y	Y	Y	Y	90%
5259	Y	Y	Y	Y	Y	Y	Y	Y	Y	Y	90%
5260	Y	Y	Y	Y	Y	Y	Y	Y	Y	Y	90%
5261	Y	Y	Y	Y	Y	Y	Y	Y	Y	Y	90%
5262	Y	Y	Y	Y	Y	Y	Y	Y	Y	Y	90%
5263	Y	Y	Y	Y	Y	Y	Y	Y	Y	Y	90%
5264	Y	Y	Y	Y	Y	Y	Y	Y	Y	Y	90%
5265	Y	Y	Y	Y	Y	Y	Y	Y	Y	Y	90%
5266	Y	Y	Y	Y	Y	Y	Y	Y	Y	Y	90%
5267	Y	Y	Y	Y	Y	Y	Y	Y	Y	Y	90%
5268	Y	Y	Y	Y	Y	Y	Y	Y	Y	Y	90%
5269	Y	Y	Y	Y	Y	Y	Y	Y	Y	Y	90%
5270	Y	Y	Y	Y	Y	Y	Y	Y	Y	Y	90%
5271	Y	Y	Y	Y	Y	Y	Y	Y	Y	Y	90%
5272	Y	Y	Y	Y	Y	Y	Y	Y	Y	Y	90%
5273	Y	Y	Y	Y	Y	Y	Y	Y	Y	Y	90%
5274	Y	Y	Y	Y	Y	Y	Y	Y	Y	Y	90%
5275	Y	Y	Y	Y	Y	Y	Y	Y	Y	Y	90%
5276	Y	Y	Y	Y	Y	Y	Y	Y	Y	Y	90%
5277	Y	Y	Y	Y	Y	Y	Y	Y	Y	Y	90%
5278	Y	Y	Y	Y	Y	Y	Y	Y	Y	Y	90%
5279	Y	Y	Y	Y	Y	Y	Y	Y	Y	Y	90%
5280	Y	Y	Y	Y	Y	Y	Y	Y	Y	Y	90%
5281	Y	Y	Y	Y	Y	Y	Y	Y	Y	Y	90%
5282	Y	Y	Y	Y	Y	Y	Y	Y	Y	Y	90%
5283	Y	Y	Y	Y	Y	Y	Y	Y	Y	Y	90%
5284	Y	Y	Y	Y	Y	Y	Y	Y	Y	Y	90%

5285	Y	Y	Y	Y	Y	Y	Y	Y	Y	Y	90%
5286	Y	Y	Y	Y	Y	Y	Y	Y	Y	Y	90%
5287	Y	Y	Y	Y	Y	Y	Y	Y	Y	Y	90%
5288	Y	Y	Y	Y	Y	Y	Y	Y	Y	Y	90%
5289	Y	Y	Y	Y	Y	Y	Y	Y	Y	Y	90%
5290	Y	Y	Y	Y	Y	Y	Y	Y	Y	Y	90%
5291	Y	Y	Y	Y	Y	Y	Y	Y	Y	Y	90%
5292	Y	Y	Y	Y	Y	Y	Y	Y	Y	Y	90%
5293	Y	Y	Y	Y	Y	Y	Y	Y	Y	Y	90%
5294	Y	Y	Y	Y	Y	Y	Y	Y	Y	Y	90%
5295	Y	Y	Y	Y	Y	Y	Y	Y	Y	Y	90%
5296	Y	Y	Y	Y	Y	Y	Y	Y	Y	Y	90%
5297	Y	Y	Y	Y	Y	Y	Y	Y	Y	Y	90%
5298	Y	Y	Y	Y	Y	Y	Y	Y	Y	Y	90%
5299	Y	Y	Y	Y	Y	Y	Y	Y	Y	Y	90%
5300	Y	Y	Y	Y	Y	Y	Y	Y	Y	Y	90%
5301	Y	Y	Y	Y	Y	Y	Y	Y	Y	Y	90%
5302	Y	Y	Y	Y	Y	Y	Y	Y	Y	Y	90%
5303	Y	Y	Y	Y	Y	Y	Y	Y	Y	Y	90%
5304	Y	Y	Y	Y	Y	Y	Y	Y	Y	Y	90%
5305	Y	Y	Y	Y	Y	Y	Y	Y	Y	Y	90%
5306	Y	Y	Y	Y	Y	Y	Y	Y	Y	Y	90%
5307	Y	Y	Y	Y	Y	Y	Y	Y	Y	Y	90%
5308	Y	Y	Y	Y	Y	Y	Y	Y	Y	Y	90%
5309	Y	Y	Y	Y	Y	Y	Y	Y	Y	Y	90%
5310	Y	Y	Y	Y	Y	Y	Y	Y	Y	Y	90%
5311	Y	Y	Y	Y	Y	Y	Y	Y	Y	Y	90%
5312	Y	Y	Y	Y	Y	Y	Y	Y	Y	Y	90%
5313	Y	Y	Y	Y	Y	Y	Y	Y	Y	Y	90%
5314	Y	Y	Y	Y	Y	Y	Y	Y	Y	Y	90%
5315	Y	Y	Y	Y	Y	Y	Y	Y	Y	Y	90%
5316	Y	Y	Y	Y	Y	Y	Y	Y	Y	Y	90%
5317	Y	Y	Y	Y	Y	Y	Y	Y	Y	Y	90%
5318	Y	Y	Y	Y	Y	Y	Y	Y	Y	Y	90%
5319	Y	Y	Y	Y	Y	Y	Y	Y	Y	Y	90%
5320	Y	Y	Y	Y	Y	Y	Y	Y	Y	Y	90%
5321	Y	Y	Y	Y	Y	Y	Y	Y	Y	Y	90%
5322	Y	Y	Y	Y	Y	Y	Y	Y	Y	Y	90%
5323	Y	Y	Y	Y	Y	Y	Y	Y	Y	Y	90%
5324	Y	Y	Y	Y	Y	Y	Y	Y	Y	Y	90%
5325	Y	Y	Y	Y	Y	Y	Y	Y	Y	Y	90%
5326	Y	Y	Y	Y	Y	Y	Y	Y	Y	Y	90%
5327	Y	Y	Y	Y	Y	Y	Y	Y	Y	Y	90%
5328	Y	Y	Y	Y	Y	Y	Y	Y	Y	Y	90%

5329	Y	Y	Y	Y	Y	Y	Y	Y	Y	Y	90%
------	---	---	---	---	---	---	---	---	---	---	-----

Result: Pass: 100%

For 80MHz BW

center Frequency : 5530

99% BW : 76.23

Detection range: F low= 5491.885 F high= 5568.115

DFS Detection Trials

Frequency	1	2	3	4	5	6	7	8	9	10	Limit
5491	Y	Y	Y	Y	Y	Y	Y	Y	Y	Y	90%
5492	Y	Y	Y	Y	Y	Y	Y	Y	Y	Y	90%
5493	Y	Y	Y	Y	Y	Y	Y	Y	Y	Y	90%
5494	Y	Y	Y	Y	Y	Y	Y	Y	Y	Y	90%
5495	Y	Y	Y	Y	Y	Y	Y	Y	Y	Y	90%
5496	Y	Y	Y	Y	Y	Y	Y	Y	Y	Y	90%
5497	Y	Y	Y	Y	Y	Y	Y	Y	Y	Y	90%
5498	Y	Y	Y	Y	Y	Y	Y	Y	Y	Y	90%
5499	Y	Y	Y	Y	Y	Y	Y	Y	Y	Y	90%
5500	Y	Y	Y	Y	Y	Y	Y	Y	Y	Y	90%
5501	Y	Y	Y	Y	Y	Y	Y	Y	Y	Y	90%
5502	Y	Y	Y	Y	Y	Y	Y	Y	Y	Y	90%
5503	Y	Y	Y	Y	Y	Y	Y	Y	Y	Y	90%
5504	Y	Y	Y	Y	Y	Y	Y	Y	Y	Y	90%
5505	Y	Y	Y	Y	Y	Y	Y	Y	Y	Y	90%
5506	Y	Y	Y	Y	Y	Y	Y	Y	Y	Y	90%
5507	Y	Y	Y	Y	Y	Y	Y	Y	Y	Y	90%
5508	Y	Y	Y	Y	Y	Y	Y	Y	Y	Y	90%
5509	Y	Y	Y	Y	Y	Y	Y	Y	Y	Y	90%
5510	Y	Y	Y	Y	Y	Y	Y	Y	Y	Y	90%
5511	Y	Y	Y	Y	Y	Y	Y	Y	Y	Y	90%
5512	Y	Y	Y	Y	Y	Y	Y	Y	Y	Y	90%
5513	Y	Y	Y	Y	Y	Y	Y	Y	Y	Y	90%
5514	Y	Y	Y	Y	Y	Y	Y	Y	Y	Y	90%
5515	Y	Y	Y	Y	Y	Y	Y	Y	Y	Y	90%
5516	Y	Y	Y	Y	Y	Y	Y	Y	Y	Y	90%
5517	Y	Y	Y	Y	Y	Y	Y	Y	Y	Y	90%
5518	Y	Y	Y	Y	Y	Y	Y	Y	Y	Y	90%
5519	Y	Y	Y	Y	Y	Y	Y	Y	Y	Y	90%
5520	Y	Y	Y	Y	Y	Y	Y	Y	Y	Y	90%
5521	Y	Y	Y	Y	Y	Y	Y	Y	Y	Y	90%
5522	Y	Y	Y	Y	Y	Y	Y	Y	Y	Y	90%
5523	Y	Y	Y	Y	Y	Y	Y	Y	Y	Y	90%
5524	Y	Y	Y	Y	Y	Y	Y	Y	Y	Y	90%

5525	Y	Y	Y	Y	Y	Y	Y	Y	Y	Y	90%
5526	Y	Y	Y	Y	Y	Y	Y	Y	Y	Y	90%
5527	Y	Y	Y	Y	Y	Y	Y	Y	Y	Y	90%
5528	Y	Y	Y	Y	Y	Y	Y	Y	Y	Y	90%
5529	Y	Y	Y	Y	Y	Y	Y	Y	Y	Y	90%
5530	Y	Y	Y	Y	Y	Y	Y	Y	Y	Y	90%
5531	Y	Y	Y	Y	Y	Y	Y	Y	Y	Y	90%
5532	Y	Y	Y	Y	Y	Y	Y	Y	Y	Y	90%
5533	Y	Y	Y	Y	Y	Y	Y	Y	Y	Y	90%
5534	Y	Y	Y	Y	Y	Y	Y	Y	Y	Y	90%
5535	Y	Y	Y	Y	Y	Y	Y	Y	Y	Y	90%
5536	Y	Y	Y	Y	Y	Y	Y	Y	Y	Y	90%
5537	Y	Y	Y	Y	Y	Y	Y	Y	Y	Y	90%
5538	Y	Y	Y	Y	Y	Y	Y	Y	Y	Y	90%
5539	Y	Y	Y	Y	Y	Y	Y	Y	Y	Y	90%
5540	Y	Y	Y	Y	Y	Y	Y	Y	Y	Y	90%
5541	Y	Y	Y	Y	Y	Y	Y	Y	Y	Y	90%
5542	Y	Y	Y	Y	Y	Y	Y	Y	Y	Y	90%
5543	Y	Y	Y	Y	Y	Y	Y	Y	Y	Y	90%
5544	Y	Y	Y	Y	Y	Y	Y	Y	Y	Y	90%
5545	Y	Y	Y	Y	Y	Y	Y	Y	Y	Y	90%
5546	Y	Y	Y	Y	Y	Y	Y	Y	Y	Y	90%
5547	Y	Y	Y	Y	Y	Y	Y	Y	Y	Y	90%
5548	Y	Y	Y	Y	Y	Y	Y	Y	Y	Y	90%
5549	Y	Y	Y	Y	Y	Y	Y	Y	Y	Y	90%
5550	Y	Y	Y	Y	Y	Y	Y	Y	Y	Y	90%
5551	Y	Y	Y	Y	Y	Y	Y	Y	Y	Y	90%
5552	Y	Y	Y	Y	Y	Y	Y	Y	Y	Y	90%
5553	Y	Y	Y	Y	Y	Y	Y	Y	Y	Y	90%
5554	Y	Y	Y	Y	Y	Y	Y	Y	Y	Y	90%
5555	Y	Y	Y	Y	Y	Y	Y	Y	Y	Y	90%
5556	Y	Y	Y	Y	Y	Y	Y	Y	Y	Y	90%
5557	Y	Y	Y	Y	Y	Y	Y	Y	Y	Y	90%
5558	Y	Y	Y	Y	Y	Y	Y	Y	Y	Y	90%
5559	Y	Y	Y	Y	Y	Y	Y	Y	Y	Y	90%
5560	Y	Y	Y	Y	Y	Y	Y	Y	Y	Y	90%
5561	Y	Y	Y	Y	Y	Y	Y	Y	Y	Y	90%
5562	Y	Y	Y	Y	Y	Y	Y	Y	Y	Y	90%
5563	Y	Y	Y	Y	Y	Y	Y	Y	Y	Y	90%
5564	Y	Y	Y	Y	Y	Y	Y	Y	Y	Y	90%
5565	Y	Y	Y	Y	Y	Y	Y	Y	Y	Y	90%
5566	Y	Y	Y	Y	Y	Y	Y	Y	Y	Y	90%
5567	Y	Y	Y	Y	Y	Y	Y	Y	Y	Y	90%
5568	Y	Y	Y	Y	Y	Y	Y	Y	Y	Y	90%

5569	Y	Y	Y	Y	Y	Y	Y	Y	Y	Y	90%
------	---	---	---	---	---	---	---	---	---	---	-----

Result: Pass: 100%

In-services monitoring

5250-5350 Test type: all --> 0/1a/1b/2/3/4/5/6
20MHz BW

Radar Type	Trial #	Freq(MHz)	Detection(Y/N)
Radar Type 0	1	5260	Y
Radar Type 0	2	5260	Y
Radar Type 0	3	5260	Y
Radar Type 0	4	5260	N
Radar Type 0	5	5260	Y
Radar Type 0	6	5260	Y
Radar Type 0	7	5260	Y
Radar Type 0	8	5260	N
Radar Type 0	9	5260	Y
Radar Type 0	10	5260	Y
Radar Type 0	11	5260	Y
Radar Type 0	12	5260	Y
Radar Type 0	13	5260	Y
Radar Type 0	14	5260	N
Radar Type 0	15	5260	Y
Radar Type 0	16	5260	Y
Radar Type 0	17	5260	Y
Radar Type 0	18	5260	Y
Radar Type 0	19	5260	Y
Radar Type 0	20	5260	Y
Radar Type 0	21	5260	Y
Radar Type 0	22	5260	Y
Radar Type 0	23	5260	Y
Radar Type 0	24	5260	Y
Radar Type 0	25	5260	Y
Radar Type 0	26	5260	N
Radar Type 0	27	5260	N
Radar Type 0	28	5260	N
Radar Type 0	29	5260	Y
Radar Type 0	30	5260	Y
Total Detection Number		24	
Result			
Detection threshold	80	%	
Limit	60	%	

Radar Type	Trial #	Freq(MHz)	Detection(Y/N)
Radar Type 1a	1	5260	N
Radar Type 1a	2	5260	Y
Radar Type 1a	3	5260	Y
Radar Type 1a	4	5260	Y
Radar Type 1a	5	5260	N
Radar Type 1a	6	5260	Y
Radar Type 1a	7	5260	Y
Radar Type 1a	8	5260	Y
Radar Type 1a	9	5260	Y
Radar Type 1a	10	5260	Y
Radar Type 1a	11	5260	Y
Radar Type 1a	12	5260	Y
Radar Type 1a	13	5260	Y
Radar Type 1a	14	5260	Y
Radar Type 1a	15	5260	N
Radar Type 1a	16	5260	Y
Radar Type 1a	17	5260	Y
Radar Type 1a	18	5260	Y
Radar Type 1a	19	5260	Y
Radar Type 1a	20	5260	Y
Radar Type 1a	21	5260	N
Radar Type 1a	22	5260	Y
Radar Type 1a	23	5260	Y
Radar Type 1a	24	5260	Y
Radar Type 1a	25	5260	Y
Radar Type 1a	26	5260	Y
Radar Type 1a	27	5260	Y
Radar Type 1a	28	5260	Y
Radar Type 1a	29	5260	Y
Radar Type 1a	30	5260	Y
Total Detection Number		26	
Result			
Detection threshold	86.66666667		%
Limit	60		%

Radar Type	Trial #	Freq(MHz)	Detection(Y/N)
Radar Type 1b	1	5260	Y
Radar Type 1b	2	5260	Y
Radar Type 1b	3	5260	Y
Radar Type 1b	4	5260	N
Radar Type 1b	5	5260	Y
Radar Type 1b	6	5260	Y
Radar Type 1b	7	5260	Y
Radar Type 1b	8	5260	Y
Radar Type 1b	9	5260	N
Radar Type 1b	10	5260	Y
Radar Type 1b	11	5260	Y
Radar Type 1b	12	5260	Y
Radar Type 1b	13	5260	Y
Radar Type 1b	14	5260	Y
Radar Type 1b	15	5260	Y
Radar Type 1b	16	5260	Y
Radar Type 1b	17	5260	Y
Radar Type 1b	18	5260	Y
Radar Type 1b	19	5260	Y
Radar Type 1b	20	5260	Y
Radar Type 1b	21	5260	Y
Radar Type 1b	22	5260	Y
Radar Type 1b	23	5260	N
Radar Type 1b	24	5260	Y
Radar Type 1b	25	5260	Y
Radar Type 1b	26	5260	N
Radar Type 1b	27	5260	Y
Radar Type 1b	28	5260	Y
Radar Type 1b	29	5260	Y
Radar Type 1b	30	5260	Y
Total Detection Number		26	
Result			
Detection threshold	86.66666667		%
Limit	60		%

Radar Type	Trial #	Freq(MHz)	Detection(Y/N)
Radar Type 2	1	5260	Y
Radar Type 2	2	5260	Y
Radar Type 2	3	5260	Y
Radar Type 2	4	5260	Y
Radar Type 2	5	5260	Y
Radar Type 2	6	5260	Y
Radar Type 2	7	5260	Y
Radar Type 2	8	5260	Y
Radar Type 2	9	5260	Y
Radar Type 2	10	5260	Y
Radar Type 2	11	5260	Y
Radar Type 2	12	5260	Y
Radar Type 2	13	5260	Y
Radar Type 2	14	5260	Y
Radar Type 2	15	5260	Y
Radar Type 2	16	5260	Y
Radar Type 2	17	5260	N
Radar Type 2	18	5260	Y
Radar Type 2	19	5260	N
Radar Type 2	20	5260	Y
Radar Type 2	21	5260	Y
Radar Type 2	22	5260	Y
Radar Type 2	23	5260	N
Radar Type 2	24	5260	N
Radar Type 2	25	5260	N
Radar Type 2	26	5260	Y
Radar Type 2	27	5260	Y
Radar Type 2	28	5260	Y
Radar Type 2	29	5260	Y
Radar Type 2	30	5260	N
Total Detection Number		24	
Result			
Detection threshold	80	%	
Limit	60	%	

Radar Type	Trial #	Freq(MHz)	Detection(Y/N)
Radar Type 3	1	5260	Y
Radar Type 3	2	5260	Y
Radar Type 3	3	5260	Y
Radar Type 3	4	5260	Y
Radar Type 3	5	5260	Y
Radar Type 3	6	5260	Y
Radar Type 3	7	5260	Y
Radar Type 3	8	5260	Y
Radar Type 3	9	5260	Y
Radar Type 3	10	5260	Y
Radar Type 3	11	5260	Y
Radar Type 3	12	5260	N
Radar Type 3	13	5260	Y
Radar Type 3	14	5260	Y
Radar Type 3	15	5260	Y
Radar Type 3	16	5260	Y
Radar Type 3	17	5260	Y
Radar Type 3	18	5260	Y
Radar Type 3	19	5260	N
Radar Type 3	20	5260	Y
Radar Type 3	21	5260	Y
Radar Type 3	22	5260	N
Radar Type 3	23	5260	Y
Radar Type 3	24	5260	Y
Radar Type 3	25	5260	N
Radar Type 3	26	5260	Y
Radar Type 3	27	5260	N
Radar Type 3	28	5260	Y
Radar Type 3	29	5260	Y
Radar Type 3	30	5260	Y
Total Detection Number		25	
Result			
Detection threshold	83.33333333		%
Limit	60		%

Radar Type	Trial #	Freq(MHz)	Detection(Y/N)
Radar Type 4	1	5260	N
Radar Type 4	2	5260	Y
Radar Type 4	3	5260	Y
Radar Type 4	4	5260	Y
Radar Type 4	5	5260	N
Radar Type 4	6	5260	Y
Radar Type 4	7	5260	Y
Radar Type 4	8	5260	N
Radar Type 4	9	5260	Y
Radar Type 4	10	5260	Y
Radar Type 4	11	5260	Y
Radar Type 4	12	5260	Y
Radar Type 4	13	5260	N
Radar Type 4	14	5260	Y
Radar Type 4	15	5260	Y
Radar Type 4	16	5260	N
Radar Type 4	17	5260	Y
Radar Type 4	18	5260	Y
Radar Type 4	19	5260	Y
Radar Type 4	20	5260	N
Radar Type 4	21	5260	Y
Radar Type 4	22	5260	N
Radar Type 4	23	5260	N
Radar Type 4	24	5260	N
Radar Type 4	25	5260	Y
Radar Type 4	26	5260	Y
Radar Type 4	27	5260	Y
Radar Type 4	28	5260	Y
Radar Type 4	29	5260	Y
Radar Type 4	30	5260	Y
Total Detection Number		21	
Result			
Detection threshold	70	%	
Limit	60	%	

TYPE 1-4 Result

Detection threshold	81.33333333	%
Limit	80	%

Radar Type	Trial #	Freq(MHz)	Detection(Y/N)
Radar Type 5	1	5260	Y
Radar Type 5	2	5260	N
Radar Type 5	3	5260	Y
Radar Type 5	4	5260	Y
Radar Type 5	5	5260	Y
Radar Type 5	6	5260	Y
Radar Type 5	7	5260	Y
Radar Type 5	8	5260	Y
Radar Type 5	9	5260	Y
Radar Type 5	10	5260	Y
Radar Type 5	11	5260	Y
Radar Type 5	12	5260	Y
Radar Type 5	13	5260	Y
Radar Type 5	14	5260	Y
Radar Type 5	15	5260	Y
Radar Type 5	16	5260	Y
Radar Type 5	17	5260	N
Radar Type 5	18	5260	Y
Radar Type 5	19	5260	Y
Radar Type 5	20	5260	Y
Radar Type 5	21	5260	Y
Radar Type 5	22	5260	Y
Radar Type 5	23	5260	Y
Radar Type 5	24	5260	Y
Radar Type 5	25	5260	Y
Radar Type 5	26	5260	Y
Radar Type 5	27	5260	Y
Radar Type 5	28	5260	N
Radar Type 5	29	5260	Y
Radar Type 5	30	5260	Y
Total Detection Number		27	
Result			
Detection threshold	90	%	
Limit	80	%	

Radar Type	Trial #	Freq(MHz)	Detection(Y/N)
Radar Type 6	1	5260	N
Radar Type 6	2	5260	Y
Radar Type 6	3	5260	Y
Radar Type 6	4	5260	Y
Radar Type 6	5	5260	N
Radar Type 6	6	5260	Y
Radar Type 6	7	5260	Y
Radar Type 6	8	5260	Y
Radar Type 6	9	5260	N
Radar Type 6	10	5260	Y
Radar Type 6	11	5260	Y
Radar Type 6	12	5260	Y
Radar Type 6	13	5260	N
Radar Type 6	14	5260	Y
Radar Type 6	15	5260	Y
Radar Type 6	16	5260	Y
Radar Type 6	17	5260	Y
Radar Type 6	18	5260	Y
Radar Type 6	19	5260	Y
Radar Type 6	20	5260	N
Radar Type 6	21	5260	N
Radar Type 6	22	5260	N
Radar Type 6	23	5260	Y
Radar Type 6	24	5260	Y
Radar Type 6	25	5260	Y
Radar Type 6	26	5260	Y
Radar Type 6	27	5260	Y
Radar Type 6	28	5260	Y
Radar Type 6	29	5260	Y
Radar Type 6	30	5260	N
Total Detection Number		22	
Result			
Detection threshold	73.33333333		%
Limit	70		%

5470-5725 Test type: all --> 0/1a/1b/2/3/4/5/6

20MHz BW

Radar Type	Trial #	Freq(MHz)	Detection(Y/N)
Radar Type 0	1	5500	N
Radar Type 0	2	5500	Y
Radar Type 0	3	5500	N
Radar Type 0	4	5500	Y
Radar Type 0	5	5500	Y
Radar Type 0	6	5500	N
Radar Type 0	7	5500	Y
Radar Type 0	8	5500	Y
Radar Type 0	9	5500	Y
Radar Type 0	10	5500	Y
Radar Type 0	11	5500	Y
Radar Type 0	12	5500	N
Radar Type 0	13	5500	Y
Radar Type 0	14	5500	Y
Radar Type 0	15	5500	N
Radar Type 0	16	5500	Y
Radar Type 0	17	5500	Y
Radar Type 0	18	5500	Y
Radar Type 0	19	5500	Y
Radar Type 0	20	5500	Y
Radar Type 0	21	5500	Y
Radar Type 0	22	5500	Y
Radar Type 0	23	5500	Y
Radar Type 0	24	5500	Y
Radar Type 0	25	5500	Y
Radar Type 0	26	5500	Y
Radar Type 0	27	5500	Y
Radar Type 0	28	5500	Y
Radar Type 0	29	5500	Y
Radar Type 0	30	5500	N
Total Detection Number		24	
Result			
Detection thresh- old	80	%	
Limit	60	%	

Radar Type	Trial #	Freq(MHz)	Detection(Y/N)
Radar Type 1a	1	5500	Y
Radar Type 1a	2	5500	Y
Radar Type 1a	3	5500	Y
Radar Type 1a	4	5500	Y
Radar Type 1a	5	5500	Y
Radar Type 1a	6	5500	Y
Radar Type 1a	7	5500	Y
Radar Type 1a	8	5500	Y
Radar Type 1a	9	5500	Y
Radar Type 1a	10	5500	Y
Radar Type 1a	11	5500	Y
Radar Type 1a	12	5500	Y
Radar Type 1a	13	5500	Y
Radar Type 1a	14	5500	Y
Radar Type 1a	15	5500	Y
Radar Type 1a	16	5500	Y
Radar Type 1a	17	5500	N
Radar Type 1a	18	5500	Y
Radar Type 1a	19	5500	N
Radar Type 1a	20	5500	Y
Radar Type 1a	21	5500	Y
Radar Type 1a	22	5500	Y
Radar Type 1a	23	5500	Y
Radar Type 1a	24	5500	Y
Radar Type 1a	25	5500	Y
Radar Type 1a	26	5500	Y
Radar Type 1a	27	5500	Y
Radar Type 1a	28	5500	N
Radar Type 1a	29	5500	Y
Radar Type 1a	30	5500	Y
Total Detection Number		27	
Result			
Detection thresh- old	90	%	
Limit	60	%	

Radar Type	Trial #	Freq(MHz)	Detection(Y/N)
Radar Type 1b	1	5500	Y
Radar Type 1b	2	5500	Y
Radar Type 1b	3	5500	Y
Radar Type 1b	4	5500	Y
Radar Type 1b	5	5500	N
Radar Type 1b	6	5500	Y
Radar Type 1b	7	5500	Y
Radar Type 1b	8	5500	Y
Radar Type 1b	9	5500	Y
Radar Type 1b	10	5500	Y
Radar Type 1b	11	5500	Y
Radar Type 1b	12	5500	Y
Radar Type 1b	13	5500	Y
Radar Type 1b	14	5500	Y
Radar Type 1b	15	5500	N
Radar Type 1b	16	5500	Y
Radar Type 1b	17	5500	Y
Radar Type 1b	18	5500	Y
Radar Type 1b	19	5500	N
Radar Type 1b	20	5500	N
Radar Type 1b	21	5500	Y
Radar Type 1b	22	5500	Y
Radar Type 1b	23	5500	Y
Radar Type 1b	24	5500	Y
Radar Type 1b	25	5500	Y
Radar Type 1b	26	5500	Y
Radar Type 1b	27	5500	N
Radar Type 1b	28	5500	Y
Radar Type 1b	29	5500	Y
Radar Type 1b	30	5500	Y
Total Detection Number		25	
Result			
Detection thresh- old	83.33333333		%
Limit	60		%

Radar Type	Trial #	Freq(MHz)	Detection(Y/N)
Radar Type 2	1	5500	Y
Radar Type 2	2	5500	Y
Radar Type 2	3	5500	Y
Radar Type 2	4	5500	N
Radar Type 2	5	5500	N
Radar Type 2	6	5500	Y
Radar Type 2	7	5500	Y
Radar Type 2	8	5500	Y
Radar Type 2	9	5500	Y
Radar Type 2	10	5500	Y
Radar Type 2	11	5500	Y
Radar Type 2	12	5500	N
Radar Type 2	13	5500	Y
Radar Type 2	14	5500	Y
Radar Type 2	15	5500	N
Radar Type 2	16	5500	Y
Radar Type 2	17	5500	Y
Radar Type 2	18	5500	N
Radar Type 2	19	5500	Y
Radar Type 2	20	5500	Y
Radar Type 2	21	5500	Y
Radar Type 2	22	5500	Y
Radar Type 2	23	5500	N
Radar Type 2	24	5500	Y
Radar Type 2	25	5500	N
Radar Type 2	26	5500	Y
Radar Type 2	27	5500	Y
Radar Type 2	28	5500	Y
Radar Type 2	29	5500	Y
Radar Type 2	30	5500	Y
Total Detection Number		23	
Result			
Detection thresh- old	76.66666667		%
Limit	60		%

Radar Type	Trial #	Freq(MHz)	Detection(Y/N)
Radar Type 3	1	5500	N
Radar Type 3	2	5500	Y
Radar Type 3	3	5500	Y
Radar Type 3	4	5500	Y
Radar Type 3	5	5500	Y
Radar Type 3	6	5500	Y
Radar Type 3	7	5500	Y
Radar Type 3	8	5500	N
Radar Type 3	9	5500	Y
Radar Type 3	10	5500	Y
Radar Type 3	11	5500	N
Radar Type 3	12	5500	Y
Radar Type 3	13	5500	Y
Radar Type 3	14	5500	N
Radar Type 3	15	5500	Y
Radar Type 3	16	5500	Y
Radar Type 3	17	5500	Y
Radar Type 3	18	5500	Y
Radar Type 3	19	5500	Y
Radar Type 3	20	5500	Y
Radar Type 3	21	5500	Y
Radar Type 3	22	5500	Y
Radar Type 3	23	5500	Y
Radar Type 3	24	5500	Y
Radar Type 3	25	5500	Y
Radar Type 3	26	5500	Y
Radar Type 3	27	5500	N
Radar Type 3	28	5500	N
Radar Type 3	29	5500	Y
Radar Type 3	30	5500	Y
Total Detection Number		24	
Result			
Detection thresh- old	80	%	
Limit	60	%	

Radar Type	Trial #	Freq(MHz)	Detection(Y/N)
Radar Type 4	1	5500	Y
Radar Type 4	2	5500	Y
Radar Type 4	3	5500	Y
Radar Type 4	4	5500	Y
Radar Type 4	5	5500	N
Radar Type 4	6	5500	Y
Radar Type 4	7	5500	N
Radar Type 4	8	5500	Y
Radar Type 4	9	5500	N
Radar Type 4	10	5500	Y
Radar Type 4	11	5500	Y
Radar Type 4	12	5500	Y
Radar Type 4	13	5500	Y
Radar Type 4	14	5500	N
Radar Type 4	15	5500	Y
Radar Type 4	16	5500	Y
Radar Type 4	17	5500	Y
Radar Type 4	18	5500	Y
Radar Type 4	19	5500	Y
Radar Type 4	20	5500	Y
Radar Type 4	21	5500	N
Radar Type 4	22	5500	Y
Radar Type 4	23	5500	Y
Radar Type 4	24	5500	N
Radar Type 4	25	5500	Y
Radar Type 4	26	5500	Y
Radar Type 4	27	5500	Y
Radar Type 4	28	5500	Y
Radar Type 4	29	5500	N
Radar Type 4	30	5500	Y
Total Detection Number		23	
Result			
Detection thresh- old	76.66666667		%
Limit	60		%

TYPE 1-4 Result

Detection thresh- old	81.33333333	%
Limit	80	%

Radar Type	Trial #	Freq(MHz)	Detection(Y/N)
Radar Type 5	1	5500	N
Radar Type 5	2	5500	Y
Radar Type 5	3	5500	Y
Radar Type 5	4	5500	Y
Radar Type 5	5	5500	Y
Radar Type 5	6	5500	Y
Radar Type 5	7	5500	Y
Radar Type 5	8	5500	Y
Radar Type 5	9	5500	Y
Radar Type 5	10	5500	Y
Radar Type 5	11	5500	Y
Radar Type 5	12	5500	Y
Radar Type 5	13	5500	Y
Radar Type 5	14	5500	Y
Radar Type 5	15	5500	Y
Radar Type 5	16	5500	Y
Radar Type 5	17	5500	Y
Radar Type 5	18	5500	Y
Radar Type 5	19	5500	Y
Radar Type 5	20	5500	Y
Radar Type 5	21	5500	Y
Radar Type 5	22	5500	Y
Radar Type 5	23	5500	N
Radar Type 5	24	5500	Y
Radar Type 5	25	5500	Y
Radar Type 5	26	5500	Y
Radar Type 5	27	5500	Y
Radar Type 5	28	5500	Y
Radar Type 5	29	5500	Y
Radar Type 5	30	5500	N
Total Detection Number		27	
Result			
Detection thresh- old	90	%	
Limit	80	%	

Radar Type	Trial #	Freq(MHz)	Detection(Y/N)
Radar Type 6	1	5500	N
Radar Type 6	2	5500	Y
Radar Type 6	3	5500	Y
Radar Type 6	4	5500	Y
Radar Type 6	5	5500	Y
Radar Type 6	6	5500	Y
Radar Type 6	7	5500	N
Radar Type 6	8	5500	N
Radar Type 6	9	5500	Y
Radar Type 6	10	5500	Y
Radar Type 6	11	5500	N
Radar Type 6	12	5500	Y
Radar Type 6	13	5500	Y
Radar Type 6	14	5500	Y
Radar Type 6	15	5500	Y
Radar Type 6	16	5500	N
Radar Type 6	17	5500	Y
Radar Type 6	18	5500	Y
Radar Type 6	19	5500	Y
Radar Type 6	20	5500	Y
Radar Type 6	21	5500	Y
Radar Type 6	22	5500	Y
Radar Type 6	23	5500	Y
Radar Type 6	24	5500	Y
Radar Type 6	25	5500	Y
Radar Type 6	26	5500	Y
Radar Type 6	27	5500	N
Radar Type 6	28	5500	Y
Radar Type 6	29	5500	Y
Radar Type 6	30	5500	Y
Total Detection Number		24	
Result			
Detection thresh- old	80	%	
Limit	70	%	

40MHz BW

Radars Type	Trial #	Freq(MHz)	Detection(Y/N)
Radars Type 0	1	5510	N
Radars Type 0	2	5510	Y
Radars Type 0	3	5510	N
Radars Type 0	4	5510	Y
Radars Type 0	5	5510	Y
Radars Type 0	6	5510	Y
Radars Type 0	7	5510	Y
Radars Type 0	8	5510	Y
Radars Type 0	9	5510	Y
Radars Type 0	10	5510	Y
Radars Type 0	11	5510	Y
Radars Type 0	12	5510	Y
Radars Type 0	13	5510	Y
Radars Type 0	14	5510	N
Radars Type 0	15	5510	Y
Radars Type 0	16	5510	Y
Radars Type 0	17	5510	Y
Radars Type 0	18	5510	Y
Radars Type 0	19	5510	Y
Radars Type 0	20	5510	Y
Radars Type 0	21	5510	Y
Radars Type 0	22	5510	Y
Radars Type 0	23	5510	Y
Radars Type 0	24	5510	Y
Radars Type 0	25	5510	Y
Radars Type 0	26	5510	N
Radars Type 0	27	5510	Y
Radars Type 0	28	5510	Y
Radars Type 0	29	5510	Y
Radars Type 0	30	5510	N
Total Detection Number		25	
Result			
Detection thresh- old	83.33333333	%	
Limit	60	%	

Radar Type	Trial #	Freq(MHz)	Detection(Y/N)
Radar Type 1a	1	5510	Y
Radar Type 1a	2	5510	Y
Radar Type 1a	3	5510	N
Radar Type 1a	4	5510	N
Radar Type 1a	5	5510	Y
Radar Type 1a	6	5510	Y
Radar Type 1a	7	5510	Y
Radar Type 1a	8	5510	Y
Radar Type 1a	9	5510	N
Radar Type 1a	10	5510	Y
Radar Type 1a	11	5510	Y
Radar Type 1a	12	5510	Y
Radar Type 1a	13	5510	Y
Radar Type 1a	14	5510	Y
Radar Type 1a	15	5510	Y
Radar Type 1a	16	5510	Y
Radar Type 1a	17	5510	N
Radar Type 1a	18	5510	Y
Radar Type 1a	19	5510	Y
Radar Type 1a	20	5510	N
Radar Type 1a	21	5510	Y
Radar Type 1a	22	5510	Y
Radar Type 1a	23	5510	Y
Radar Type 1a	24	5510	Y
Radar Type 1a	25	5510	Y
Radar Type 1a	26	5510	Y
Radar Type 1a	27	5510	Y
Radar Type 1a	28	5510	Y
Radar Type 1a	29	5510	Y
Radar Type 1a	30	5510	Y
Total Detection Number		25	
Result			
Detection thresh- old	83.33333333		%
Limit	60		%

Radar Type	Trial #	Freq(MHz)	Detection(Y/N)
Radar Type 1b	1	5510	Y
Radar Type 1b	2	5510	Y
Radar Type 1b	3	5510	Y
Radar Type 1b	4	5510	Y
Radar Type 1b	5	5510	Y
Radar Type 1b	6	5510	Y
Radar Type 1b	7	5510	Y
Radar Type 1b	8	5510	Y
Radar Type 1b	9	5510	Y
Radar Type 1b	10	5510	N
Radar Type 1b	11	5510	Y
Radar Type 1b	12	5510	Y
Radar Type 1b	13	5510	Y
Radar Type 1b	14	5510	Y
Radar Type 1b	15	5510	Y
Radar Type 1b	16	5510	Y
Radar Type 1b	17	5510	Y
Radar Type 1b	18	5510	Y
Radar Type 1b	19	5510	Y
Radar Type 1b	20	5510	Y
Radar Type 1b	21	5510	Y
Radar Type 1b	22	5510	Y
Radar Type 1b	23	5510	Y
Radar Type 1b	24	5510	Y
Radar Type 1b	25	5510	Y
Radar Type 1b	26	5510	Y
Radar Type 1b	27	5510	Y
Radar Type 1b	28	5510	Y
Radar Type 1b	29	5510	Y
Radar Type 1b	30	5510	N
Total Detection Number		28	
Result			
Detection thresh- old	93.33333333		%
Limit	60		%

Radar Type	Trial #	Freq(MHz)	Detection(Y/N)
Radar Type 2	1	5510	Y
Radar Type 2	2	5510	Y
Radar Type 2	3	5510	Y
Radar Type 2	4	5510	Y
Radar Type 2	5	5510	N
Radar Type 2	6	5510	Y
Radar Type 2	7	5510	Y
Radar Type 2	8	5510	N
Radar Type 2	9	5510	Y
Radar Type 2	10	5510	Y
Radar Type 2	11	5510	N
Radar Type 2	12	5510	Y
Radar Type 2	13	5510	Y
Radar Type 2	14	5510	Y
Radar Type 2	15	5510	Y
Radar Type 2	16	5510	Y
Radar Type 2	17	5510	Y
Radar Type 2	18	5510	Y
Radar Type 2	19	5510	N
Radar Type 2	20	5510	Y
Radar Type 2	21	5510	Y
Radar Type 2	22	5510	Y
Radar Type 2	23	5510	Y
Radar Type 2	24	5510	Y
Radar Type 2	25	5510	Y
Radar Type 2	26	5510	Y
Radar Type 2	27	5510	Y
Radar Type 2	28	5510	N
Radar Type 2	29	5510	N
Radar Type 2	30	5510	N
Total Detection Number		23	
Result			
Detection thresh- old	76.66666667		%
Limit	60		%

Radar Type	Trial #	Freq(MHz)	Detection(Y/N)
Radar Type 3	1	5510	Y
Radar Type 3	2	5510	Y
Radar Type 3	3	5510	Y
Radar Type 3	4	5510	Y
Radar Type 3	5	5510	N
Radar Type 3	6	5510	Y
Radar Type 3	7	5510	Y
Radar Type 3	8	5510	Y
Radar Type 3	9	5510	Y
Radar Type 3	10	5510	Y
Radar Type 3	11	5510	Y
Radar Type 3	12	5510	Y
Radar Type 3	13	5510	N
Radar Type 3	14	5510	N
Radar Type 3	15	5510	Y
Radar Type 3	16	5510	Y
Radar Type 3	17	5510	Y
Radar Type 3	18	5510	Y
Radar Type 3	19	5510	Y
Radar Type 3	20	5510	Y
Radar Type 3	21	5510	Y
Radar Type 3	22	5510	Y
Radar Type 3	23	5510	Y
Radar Type 3	24	5510	Y
Radar Type 3	25	5510	Y
Radar Type 3	26	5510	Y
Radar Type 3	27	5510	Y
Radar Type 3	28	5510	Y
Radar Type 3	29	5510	N
Radar Type 3	30	5510	N
Total Detection Number		25	
Result			
Detection thresh- old	83.33333333		%
Limit	60		%

Radar Type	Trial #	Freq(MHz)	Detection(Y/N)
Radar Type 4	1	5510	Y
Radar Type 4	2	5510	N
Radar Type 4	3	5510	Y
Radar Type 4	4	5510	Y
Radar Type 4	5	5510	N
Radar Type 4	6	5510	Y
Radar Type 4	7	5510	Y
Radar Type 4	8	5510	N
Radar Type 4	9	5510	Y
Radar Type 4	10	5510	Y
Radar Type 4	11	5510	Y
Radar Type 4	12	5510	Y
Radar Type 4	13	5510	Y
Radar Type 4	14	5510	N
Radar Type 4	15	5510	Y
Radar Type 4	16	5510	Y
Radar Type 4	17	5510	Y
Radar Type 4	18	5510	Y
Radar Type 4	19	5510	N
Radar Type 4	20	5510	Y
Radar Type 4	21	5510	Y
Radar Type 4	22	5510	Y
Radar Type 4	23	5510	N
Radar Type 4	24	5510	N
Radar Type 4	25	5510	Y
Radar Type 4	26	5510	Y
Radar Type 4	27	5510	Y
Radar Type 4	28	5510	Y
Radar Type 4	29	5510	Y
Radar Type 4	30	5510	N
Total Detection Number		22	
Result			
Detection thresh- old	73.33333333		%
Limit	60		%

TYPE 1-4 Result

Detection thresh- old	82	%
Limit	80	%

Radar Type	Trial #	Freq(MHz)	Detection(Y/N)
Radar Type 5	1	5510	N
Radar Type 5	2	5510	N
Radar Type 5	3	5510	Y
Radar Type 5	4	5510	Y
Radar Type 5	5	5510	N
Radar Type 5	6	5510	Y
Radar Type 5	7	5510	Y
Radar Type 5	8	5510	Y
Radar Type 5	9	5510	Y
Radar Type 5	10	5510	Y
Radar Type 5	11	5510	Y
Radar Type 5	12	5510	Y
Radar Type 5	13	5510	Y
Radar Type 5	14	5510	Y
Radar Type 5	15	5510	Y
Radar Type 5	16	5510	Y
Radar Type 5	17	5510	Y
Radar Type 5	18	5510	Y
Radar Type 5	19	5510	Y
Radar Type 5	20	5510	Y
Radar Type 5	21	5510	Y
Radar Type 5	22	5510	Y
Radar Type 5	23	5510	N
Radar Type 5	24	5510	Y
Radar Type 5	25	5510	N
Radar Type 5	26	5510	Y
Radar Type 5	27	5510	Y
Radar Type 5	28	5510	Y
Radar Type 5	29	5510	Y
Radar Type 5	30	5510	Y
Total Detection Number		25	
Result			
Detection thresh- old	83.33333333	%	
Limit	80	%	

Radars Type	Trial #	Freq(MHz)	Detection(Y/N)
Radars Type 6	1	5510	Y
Radars Type 6	2	5510	Y
Radars Type 6	3	5510	Y
Radars Type 6	4	5510	Y
Radars Type 6	5	5510	Y
Radars Type 6	6	5510	Y
Radars Type 6	7	5510	Y
Radars Type 6	8	5510	Y
Radars Type 6	9	5510	Y
Radars Type 6	10	5510	Y
Radars Type 6	11	5510	Y
Radars Type 6	12	5510	Y
Radars Type 6	13	5510	Y
Radars Type 6	14	5510	Y
Radars Type 6	15	5510	Y
Radars Type 6	16	5510	Y
Radars Type 6	17	5510	Y
Radars Type 6	18	5510	Y
Radars Type 6	19	5510	Y
Radars Type 6	20	5510	Y
Radars Type 6	21	5510	Y
Radars Type 6	22	5510	Y
Radars Type 6	23	5510	Y
Radars Type 6	24	5510	Y
Radars Type 6	25	5510	Y
Radars Type 6	26	5510	Y
Radars Type 6	27	5510	Y
Radars Type 6	28	5510	Y
Radars Type 6	29	5510	Y
Radars Type 6	30	5510	Y
Total Detection Number		30	
Result			
Detection thresh- old	100	%	
Limit	70	%	

80MHz BW

Radars Type	Trial #	Freq(MHz)	Detection(Y/N)
Radars Type 0	1	5530	Y
Radars Type 0	2	5530	Y
Radars Type 0	3	5530	Y
Radars Type 0	4	5530	Y
Radars Type 0	5	5530	Y
Radars Type 0	6	5530	Y
Radars Type 0	7	5530	Y
Radars Type 0	8	5530	Y
Radars Type 0	9	5530	Y
Radars Type 0	10	5530	Y
Radars Type 0	11	5530	Y
Radars Type 0	12	5530	Y
Radars Type 0	13	5530	Y
Radars Type 0	14	5530	Y
Radars Type 0	15	5530	Y
Radars Type 0	16	5530	Y
Radars Type 0	17	5530	Y
Radars Type 0	18	5530	Y
Radars Type 0	19	5530	Y
Radars Type 0	20	5530	Y
Radars Type 0	21	5530	Y
Radars Type 0	22	5530	Y
Radars Type 0	23	5530	Y
Radars Type 0	24	5530	Y
Radars Type 0	25	5530	Y
Radars Type 0	26	5530	N
Radars Type 0	27	5530	Y
Radars Type 0	28	5530	Y
Radars Type 0	29	5530	Y
Radars Type 0	30	5530	Y
Total Detection Number		29	
Result			
Detection thresh- old	96.66666667		%
Limit	60		%

Radar Type	Trial #	Freq(MHz)	Detection(Y/N)
Radar Type 1a	1	5530	N
Radar Type 1a	2	5530	Y
Radar Type 1a	3	5530	Y
Radar Type 1a	4	5530	Y
Radar Type 1a	5	5530	Y
Radar Type 1a	6	5530	Y
Radar Type 1a	7	5530	Y
Radar Type 1a	8	5530	Y
Radar Type 1a	9	5530	Y
Radar Type 1a	10	5530	Y
Radar Type 1a	11	5530	Y
Radar Type 1a	12	5530	Y
Radar Type 1a	13	5530	Y
Radar Type 1a	14	5530	Y
Radar Type 1a	15	5530	Y
Radar Type 1a	16	5530	Y
Radar Type 1a	17	5530	Y
Radar Type 1a	18	5530	Y
Radar Type 1a	19	5530	Y
Radar Type 1a	20	5530	Y
Radar Type 1a	21	5530	Y
Radar Type 1a	22	5530	Y
Radar Type 1a	23	5530	Y
Radar Type 1a	24	5530	Y
Radar Type 1a	25	5530	Y
Radar Type 1a	26	5530	Y
Radar Type 1a	27	5530	Y
Radar Type 1a	28	5530	Y
Radar Type 1a	29	5530	Y
Radar Type 1a	30	5530	Y
Total Detection Number		29	
Result			
Detection thresh- old	96.66666667		%
Limit	60		%

Radar Type	Trial #	Freq(MHz)	Detection(Y/N)
Radar Type 1b	1	5530	Y
Radar Type 1b	2	5530	Y
Radar Type 1b	3	5530	Y
Radar Type 1b	4	5530	Y
Radar Type 1b	5	5530	Y
Radar Type 1b	6	5530	Y
Radar Type 1b	7	5530	Y
Radar Type 1b	8	5530	Y
Radar Type 1b	9	5530	Y
Radar Type 1b	10	5530	Y
Radar Type 1b	11	5530	Y
Radar Type 1b	12	5530	Y
Radar Type 1b	13	5530	Y
Radar Type 1b	14	5530	Y
Radar Type 1b	15	5530	Y
Radar Type 1b	16	5530	Y
Radar Type 1b	17	5530	Y
Radar Type 1b	18	5530	Y
Radar Type 1b	19	5530	Y
Radar Type 1b	20	5530	Y
Radar Type 1b	21	5530	Y
Radar Type 1b	22	5530	Y
Radar Type 1b	23	5530	Y
Radar Type 1b	24	5530	Y
Radar Type 1b	25	5530	Y
Radar Type 1b	26	5530	Y
Radar Type 1b	27	5530	Y
Radar Type 1b	28	5530	Y
Radar Type 1b	29	5530	Y
Radar Type 1b	30	5530	Y
Total Detection Number		30	
Result			
Detection thresh- old	100	%	
Limit	60	%	

Radar Type	Trial #	Freq(MHz)	Detection(Y/N)
Radar Type 2	1	5530	Y
Radar Type 2	2	5530	Y
Radar Type 2	3	5530	Y
Radar Type 2	4	5530	N
Radar Type 2	5	5530	Y
Radar Type 2	6	5530	Y
Radar Type 2	7	5530	N
Radar Type 2	8	5530	Y
Radar Type 2	9	5530	Y
Radar Type 2	10	5530	Y
Radar Type 2	11	5530	Y
Radar Type 2	12	5530	N
Radar Type 2	13	5530	N
Radar Type 2	14	5530	Y
Radar Type 2	15	5530	Y
Radar Type 2	16	5530	Y
Radar Type 2	17	5530	Y
Radar Type 2	18	5530	Y
Radar Type 2	19	5530	Y
Radar Type 2	20	5530	Y
Radar Type 2	21	5530	Y
Radar Type 2	22	5530	Y
Radar Type 2	23	5530	Y
Radar Type 2	24	5530	N
Radar Type 2	25	5530	Y
Radar Type 2	26	5530	Y
Radar Type 2	27	5530	Y
Radar Type 2	28	5530	Y
Radar Type 2	29	5530	Y
Radar Type 2	30	5530	N
Total Detection Number		24	
Result			
Detection thresh- old	80	%	
Limit	60	%	

Radar Type	Trial #	Freq(MHz)	Detection(Y/N)
Radar Type 3	1	5530	Y
Radar Type 3	2	5530	Y
Radar Type 3	3	5530	Y
Radar Type 3	4	5530	Y
Radar Type 3	5	5530	Y
Radar Type 3	6	5530	Y
Radar Type 3	7	5530	Y
Radar Type 3	8	5530	N
Radar Type 3	9	5530	Y
Radar Type 3	10	5530	Y
Radar Type 3	11	5530	Y
Radar Type 3	12	5530	Y
Radar Type 3	13	5530	Y
Radar Type 3	14	5530	Y
Radar Type 3	15	5530	Y
Radar Type 3	16	5530	N
Radar Type 3	17	5530	Y
Radar Type 3	18	5530	Y
Radar Type 3	19	5530	N
Radar Type 3	20	5530	Y
Radar Type 3	21	5530	Y
Radar Type 3	22	5530	Y
Radar Type 3	23	5530	N
Radar Type 3	24	5530	Y
Radar Type 3	25	5530	Y
Radar Type 3	26	5530	Y
Radar Type 3	27	5530	Y
Radar Type 3	28	5530	N
Radar Type 3	29	5530	N
Radar Type 3	30	5530	Y
Total Detection Number		24	
Result			
Detection thresh- old	80	%	
Limit	60	%	

Radar Type	Trial #	Freq(MHz)	Detection(Y/N)
Radar Type 4	1	5530	Y
Radar Type 4	2	5530	Y
Radar Type 4	3	5530	Y
Radar Type 4	4	5530	N
Radar Type 4	5	5530	Y
Radar Type 4	6	5530	Y
Radar Type 4	7	5530	N
Radar Type 4	8	5530	N
Radar Type 4	9	5530	Y
Radar Type 4	10	5530	Y
Radar Type 4	11	5530	N
Radar Type 4	12	5530	N
Radar Type 4	13	5530	Y
Radar Type 4	14	5530	Y
Radar Type 4	15	5530	Y
Radar Type 4	16	5530	Y
Radar Type 4	17	5530	Y
Radar Type 4	18	5530	Y
Radar Type 4	19	5530	Y
Radar Type 4	20	5530	Y
Radar Type 4	21	5530	N
Radar Type 4	22	5530	Y
Radar Type 4	23	5530	Y
Radar Type 4	24	5530	Y
Radar Type 4	25	5530	Y
Radar Type 4	26	5530	Y
Radar Type 4	27	5530	Y
Radar Type 4	28	5530	N
Radar Type 4	29	5530	Y
Radar Type 4	30	5530	Y
Total Detection Number		23	
Result			
Detection thresh- old	76.66666667		%
Limit	60		%

TYPE 1-4 Result

Detection thresh- old	86.66666667	%
Limit	80	%

Radar Type	Trial #	Freq(MHz)	Detection(Y/N)
Radar Type 5	1	5530	N
Radar Type 5	2	5530	N
Radar Type 5	3	5530	Y
Radar Type 5	4	5530	Y
Radar Type 5	5	5530	Y
Radar Type 5	6	5530	Y
Radar Type 5	7	5530	Y
Radar Type 5	8	5530	Y
Radar Type 5	9	5530	Y
Radar Type 5	10	5530	Y
Radar Type 5	11	5530	Y
Radar Type 5	12	5530	Y
Radar Type 5	13	5530	N
Radar Type 5	14	5530	Y
Radar Type 5	15	5530	Y
Radar Type 5	16	5530	Y
Radar Type 5	17	5530	Y
Radar Type 5	18	5530	Y
Radar Type 5	19	5530	Y
Radar Type 5	20	5530	Y
Radar Type 5	21	5530	Y
Radar Type 5	22	5530	Y
Radar Type 5	23	5530	Y
Radar Type 5	24	5530	Y
Radar Type 5	25	5530	Y
Radar Type 5	26	5530	Y
Radar Type 5	27	5530	Y
Radar Type 5	28	5530	Y
Radar Type 5	29	5530	Y
Radar Type 5	30	5530	Y
Total Detection Number		27	
Result			
Detection thresh- old	90	%	
Limit	80	%	

Radar Type	Trial #	Freq(MHz)	Detection(Y/N)
Radar Type 6	1	5530	Y
Radar Type 6	2	5530	Y
Radar Type 6	3	5530	Y
Radar Type 6	4	5530	Y
Radar Type 6	5	5530	Y
Radar Type 6	6	5530	Y
Radar Type 6	7	5530	Y
Radar Type 6	8	5530	Y
Radar Type 6	9	5530	Y
Radar Type 6	10	5530	Y
Radar Type 6	11	5530	Y
Radar Type 6	12	5530	Y
Radar Type 6	13	5530	Y
Radar Type 6	14	5530	Y
Radar Type 6	15	5530	Y
Radar Type 6	16	5530	Y
Radar Type 6	17	5530	Y
Radar Type 6	18	5530	Y
Radar Type 6	19	5530	Y
Radar Type 6	20	5530	Y
Radar Type 6	21	5530	Y
Radar Type 6	22	5530	Y
Radar Type 6	23	5530	Y
Radar Type 6	24	5530	Y
Radar Type 6	25	5530	Y
Radar Type 6	26	5530	Y
Radar Type 6	27	5530	Y
Radar Type 6	28	5530	Y
Radar Type 6	29	5530	Y
Radar Type 6	30	5530	Y
Total Detection Number		30	
Result			
Detection thresh- old	100	%	
Limit	70	%	

5250MHz – 5350MHz

Initial CAC time during power up of EUT

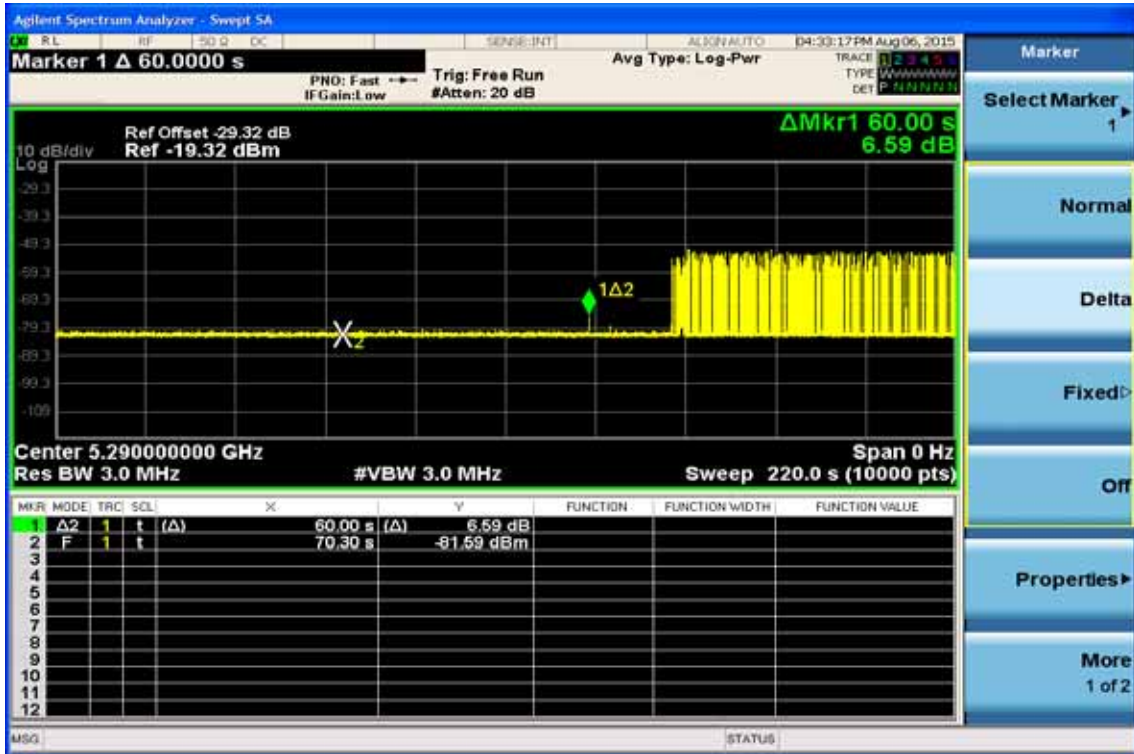

Type 0
Radar at the Begin of CAC

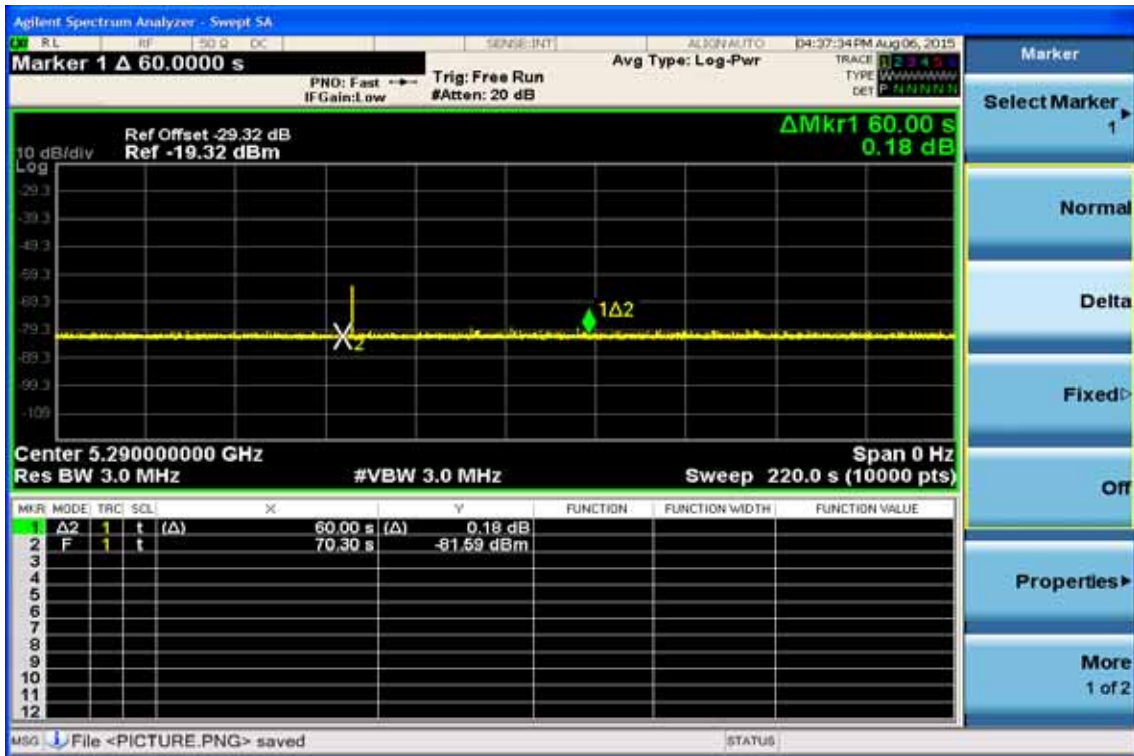

Radar at the Ending of CAC



Type 1A

Radar at the Begin of CAC

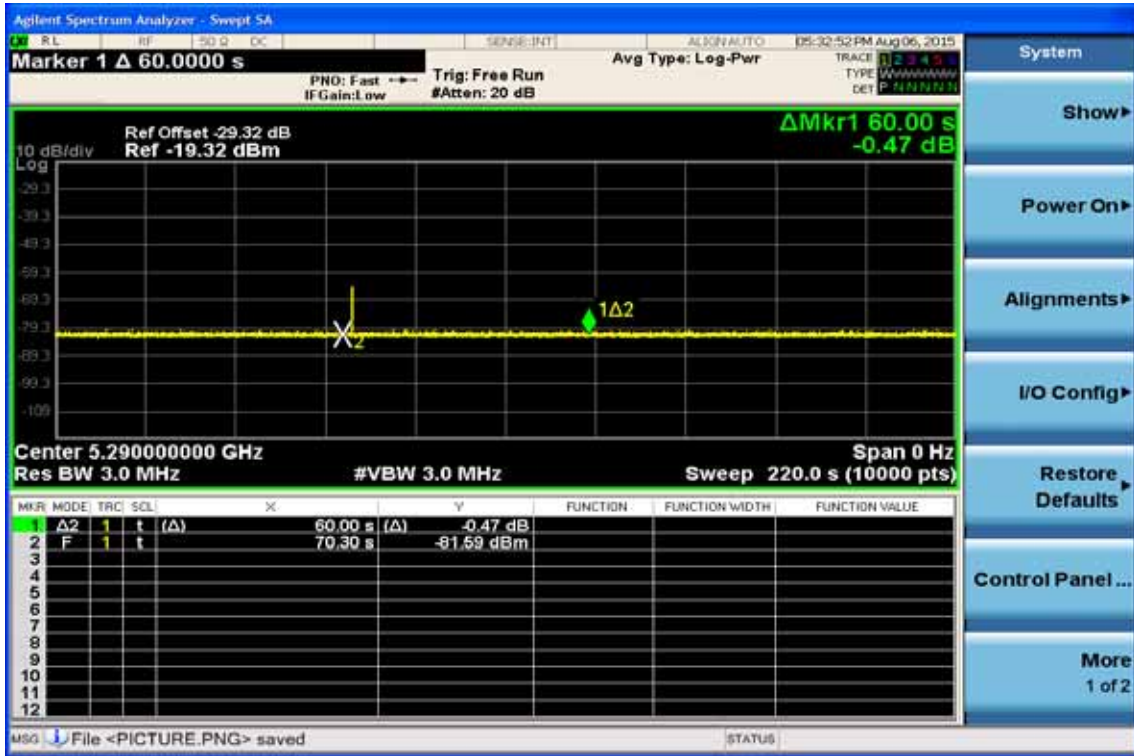

Radar at the Ending of CAC



Type 1B

Radar at the Begin of CAC



Radar at the Ending of CAC



Type 2

Radars at the Begin of CAC

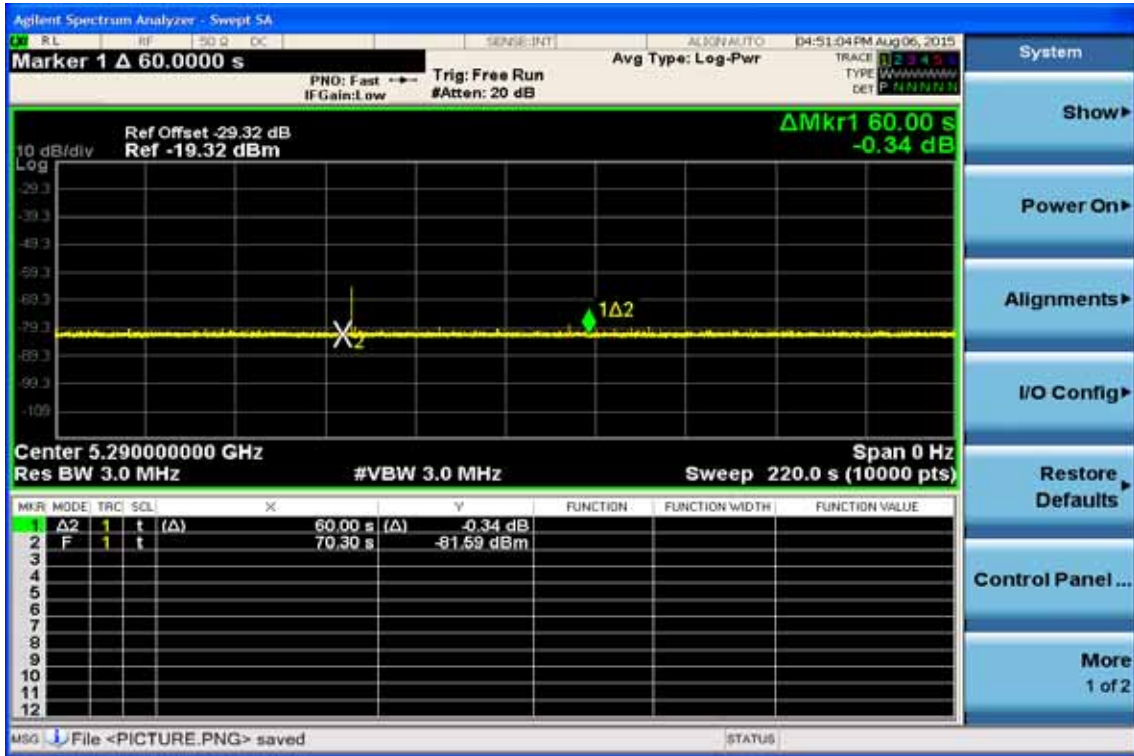

Radars at the Ending of CAC



Type 3

Radar at the Begin of CAC

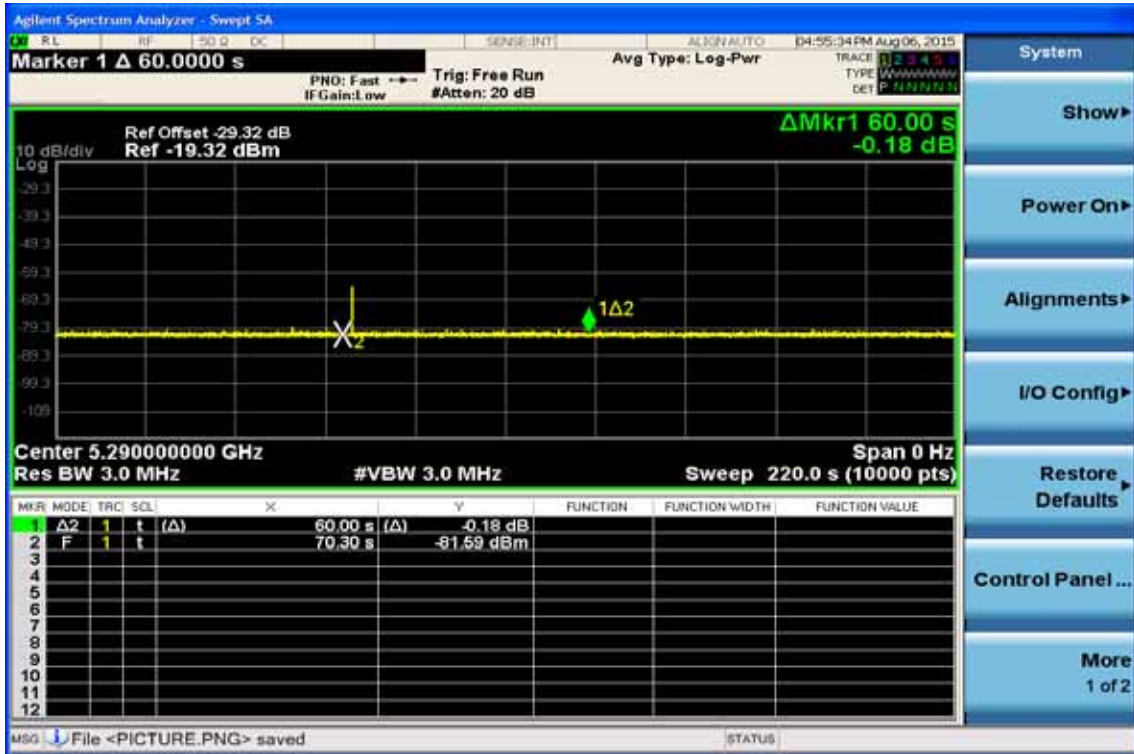

Radar at the Ending of CAC



Type 4

Radar at the Begin of CAC

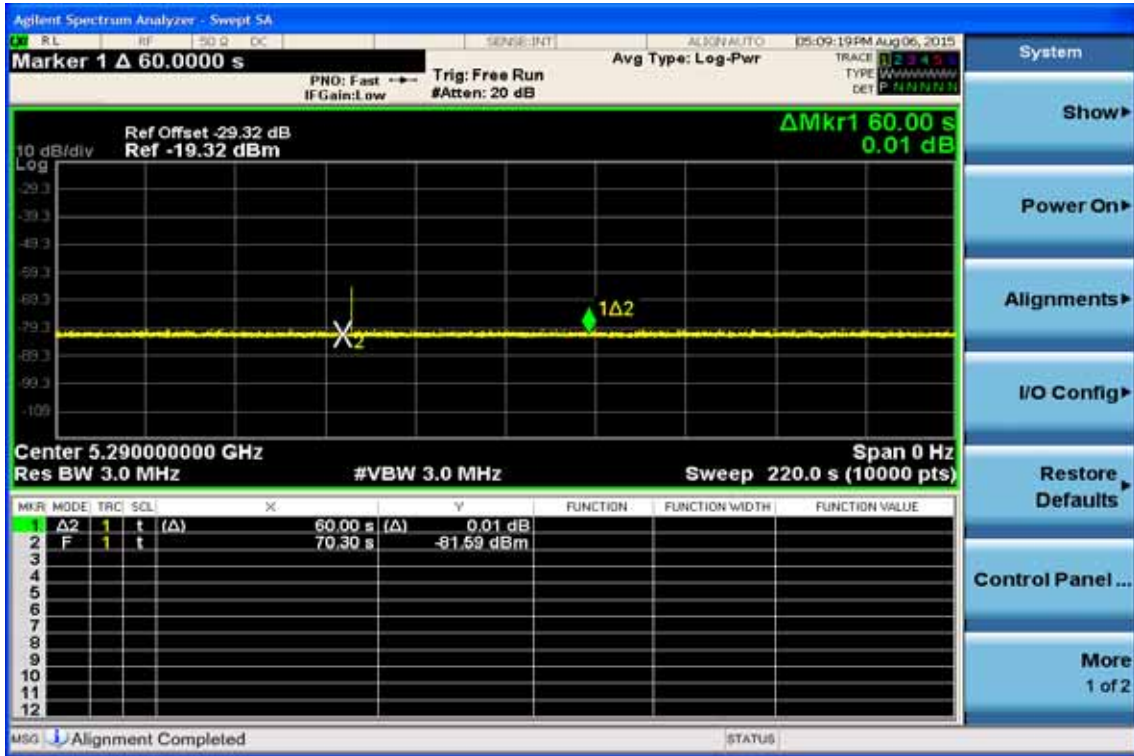

Radar at the Ending of CAC



Type 5

Radar at the Begin of CAC

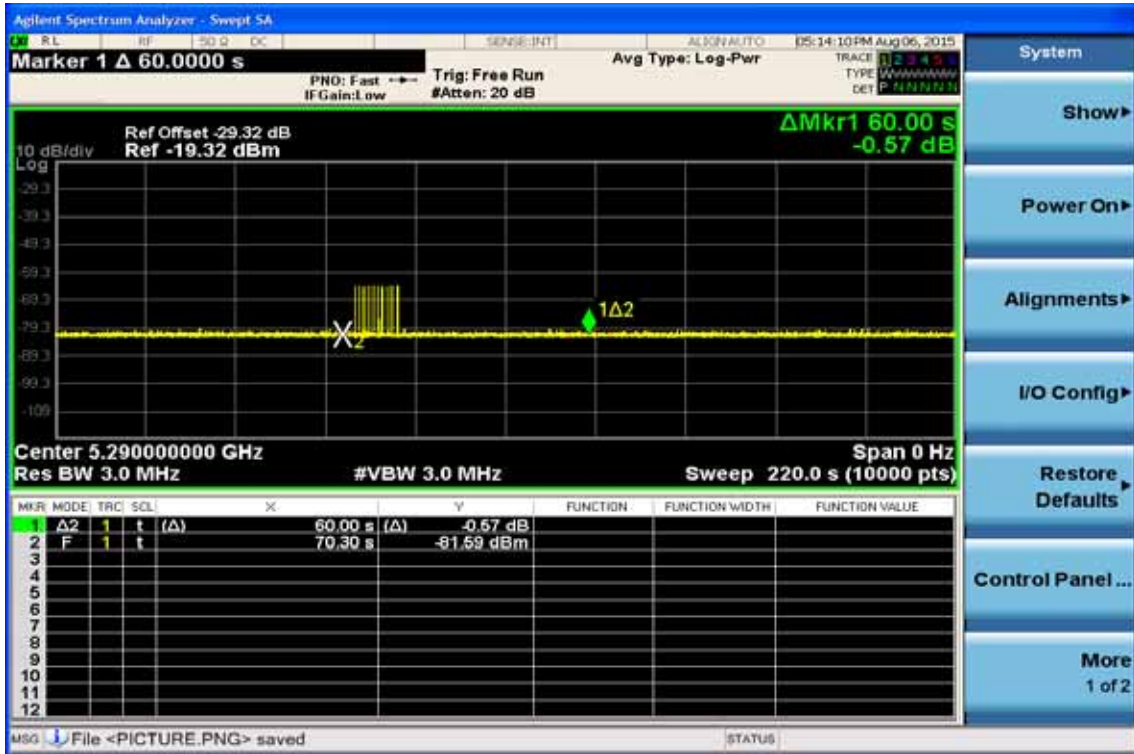

Radar at the Ending of CAC



Type 6

Radar at the Begin of CAC



Radar at the Ending of CAC



5470MHz – 5725MHz

Initial CAC time during power up of EUT

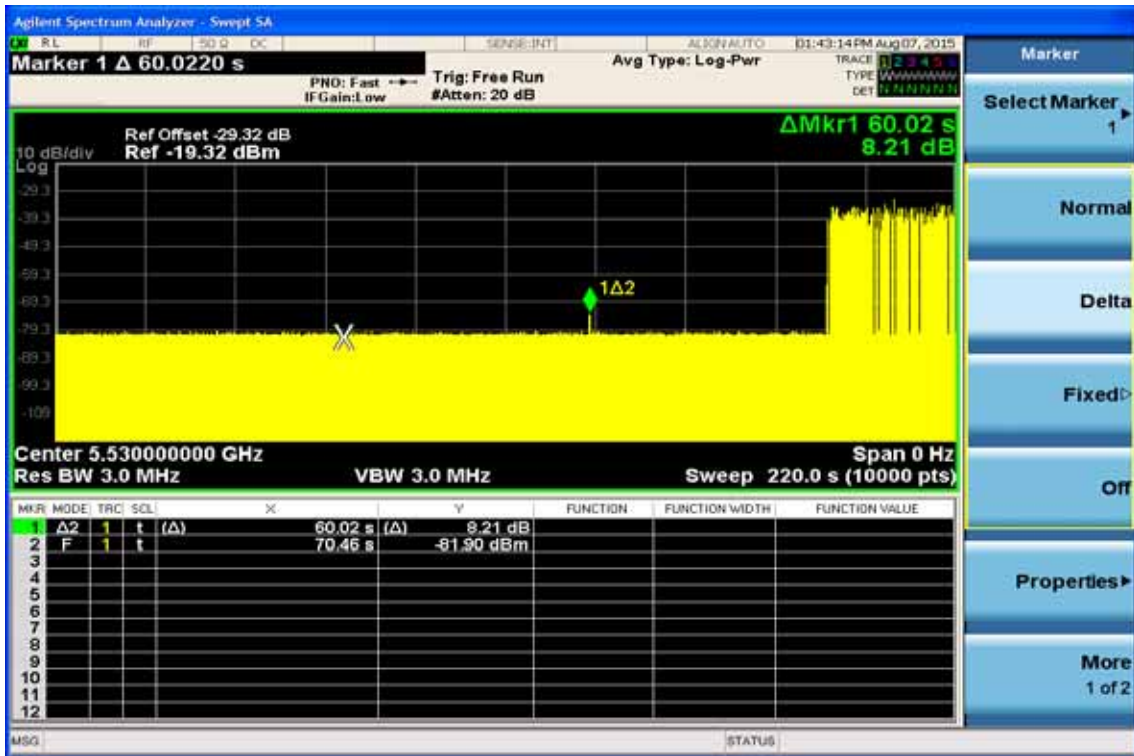

Type 0

Radars at the Begin of CAC

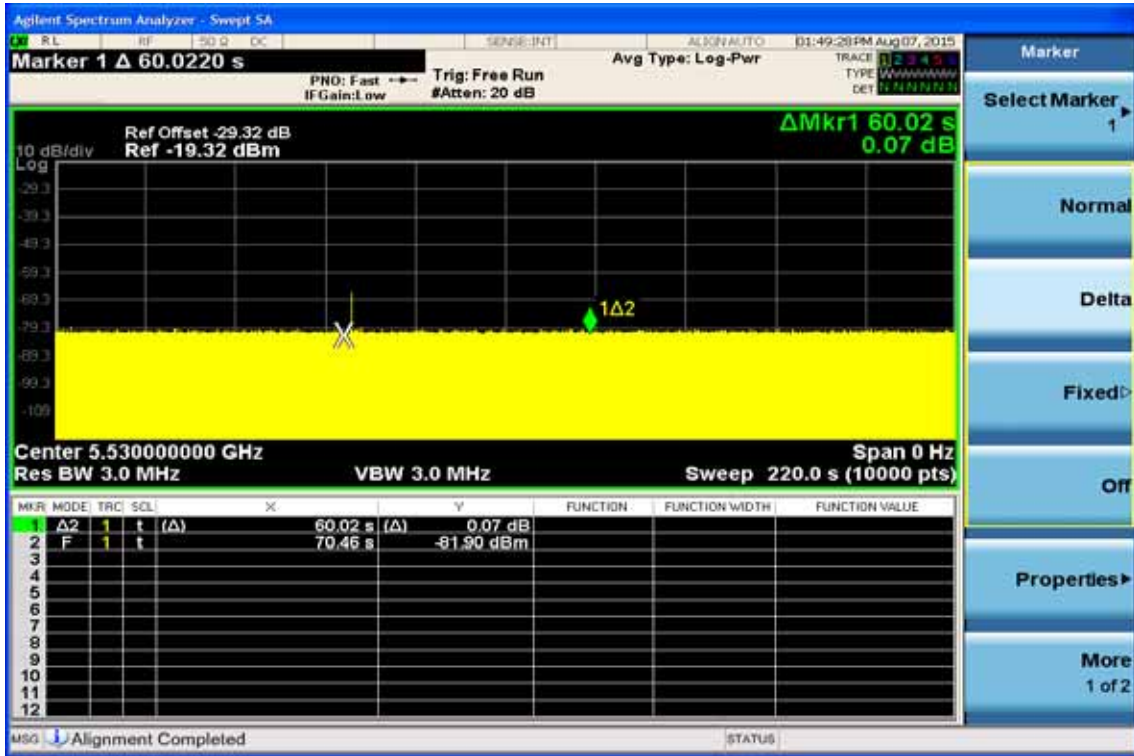

Radars at the Ending of CAC

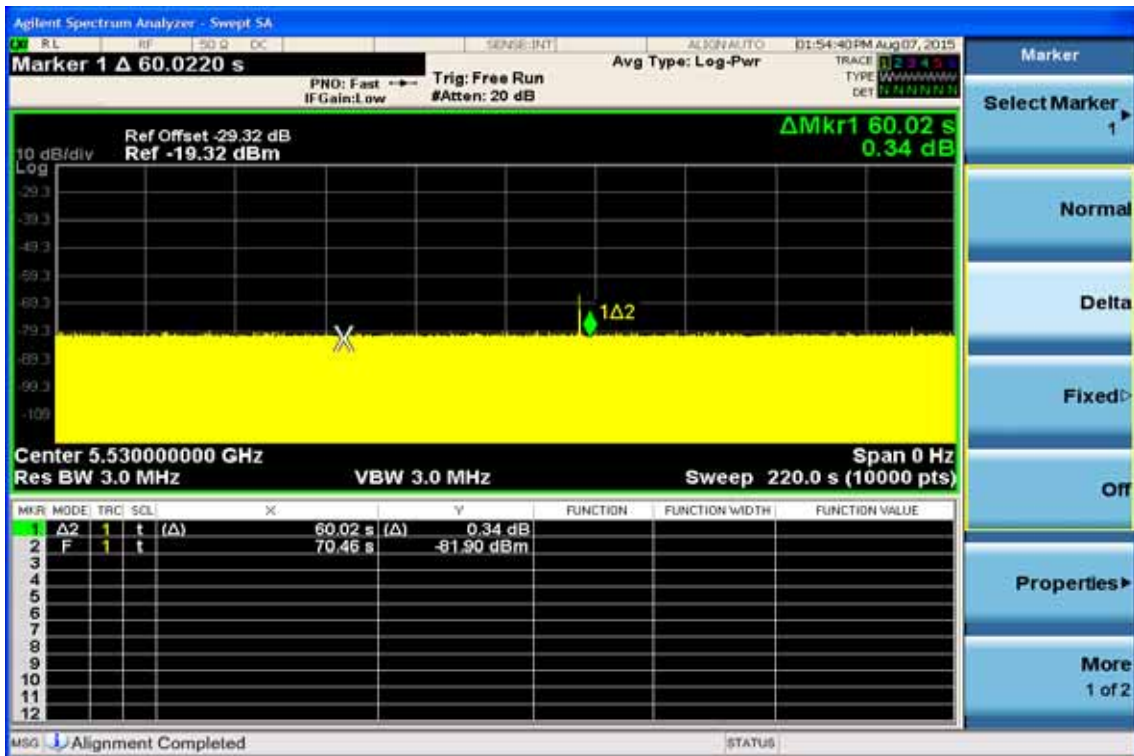

Type 1A

Radar at the Begin of CAC

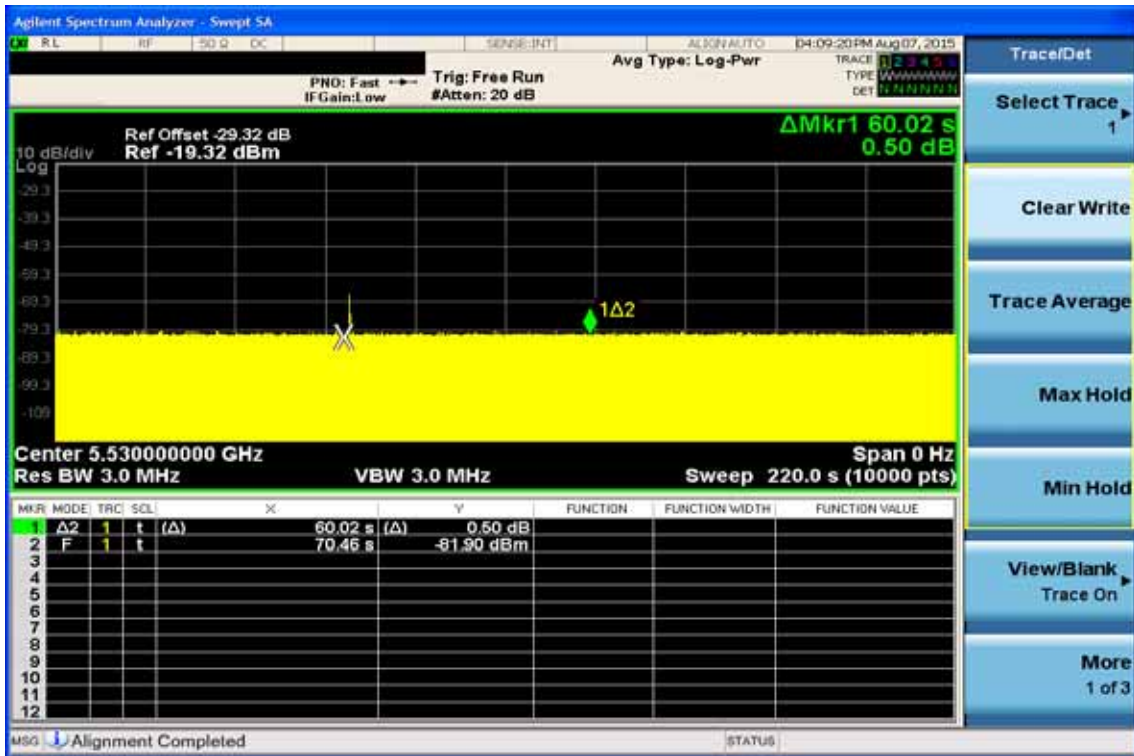

Radar at the Ending of CAC

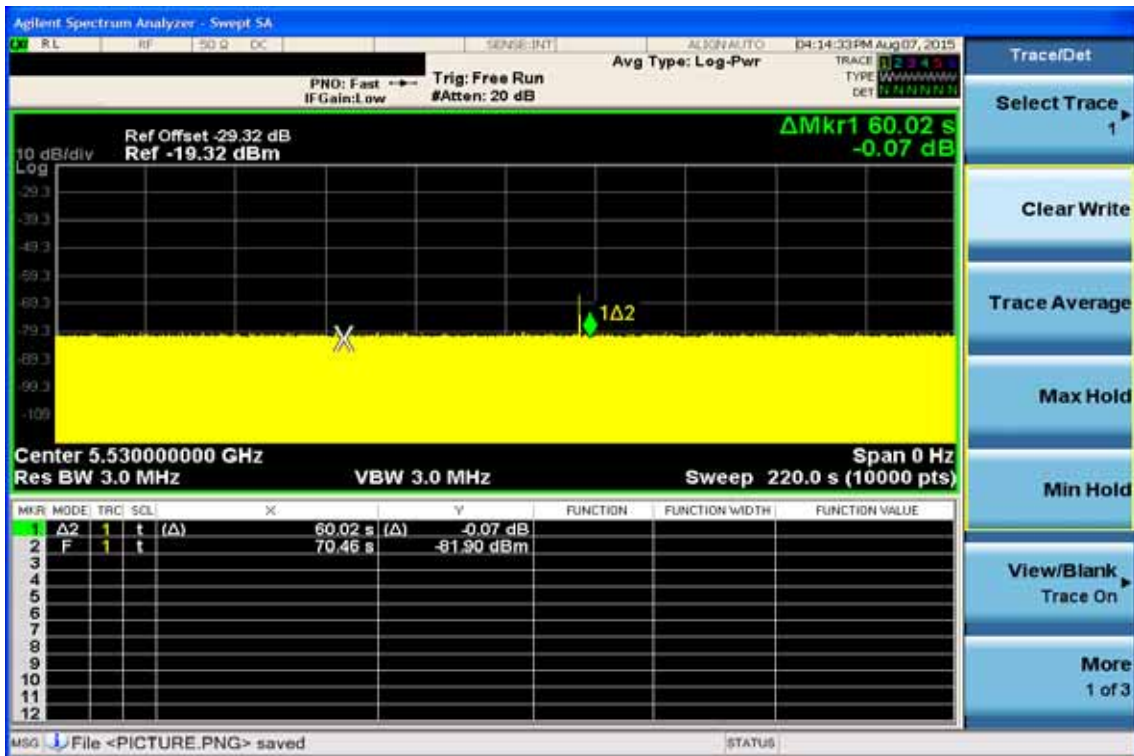

Type 1B

Radar at the Begin of CAC

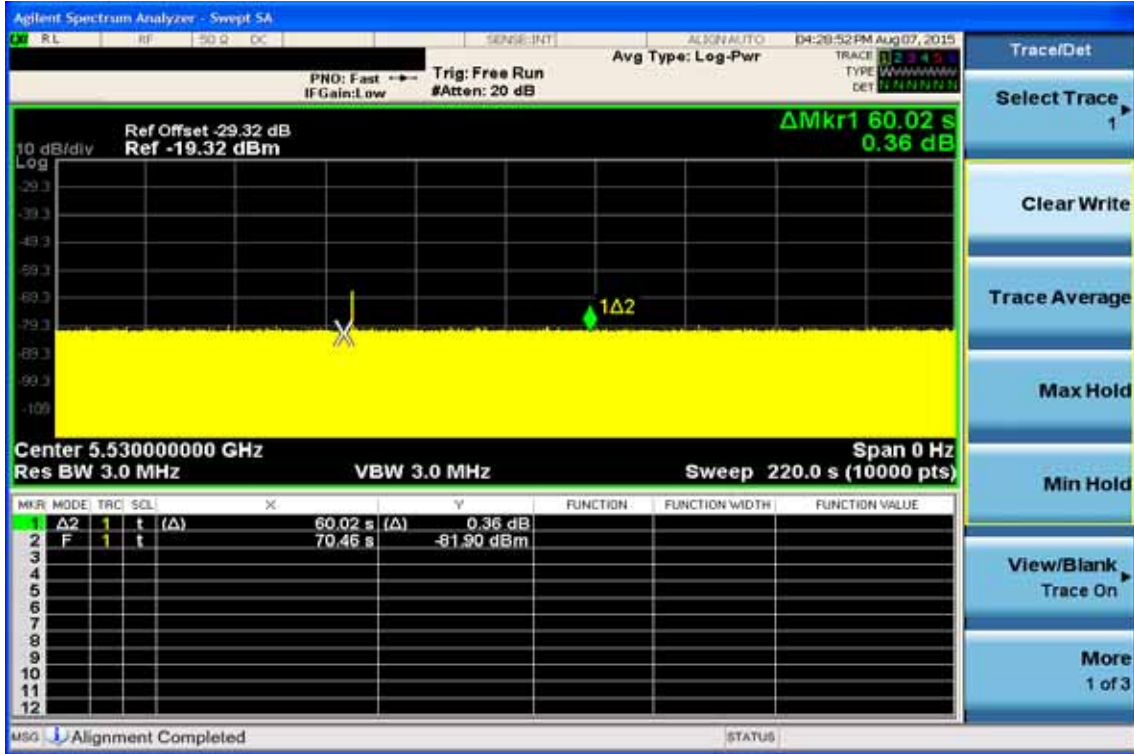

Radar at the Ending of CAC

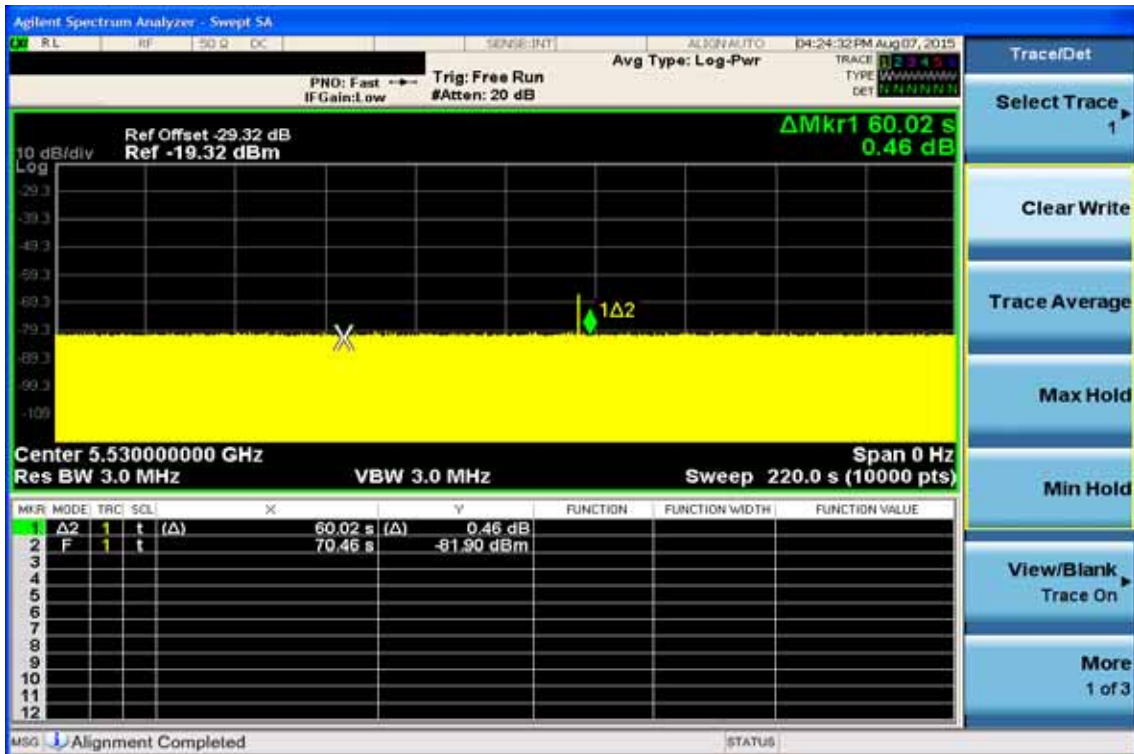

Type 2

Radar at the Begin of CAC

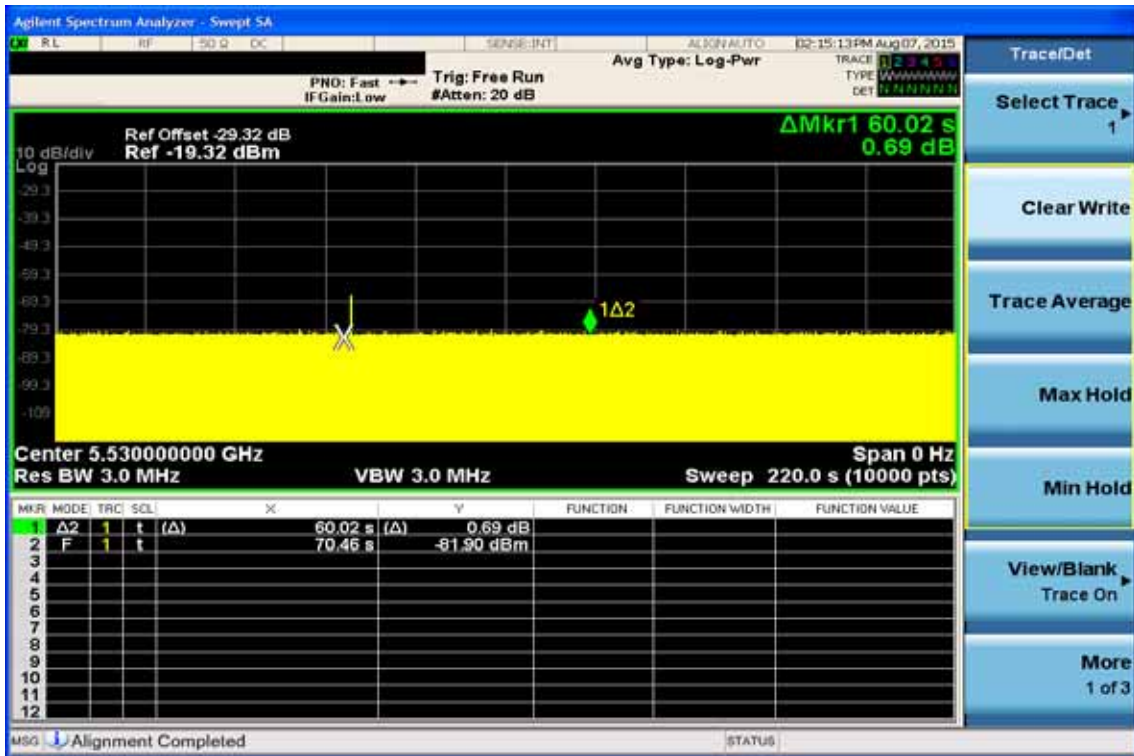

Radar at the Ending of CAC

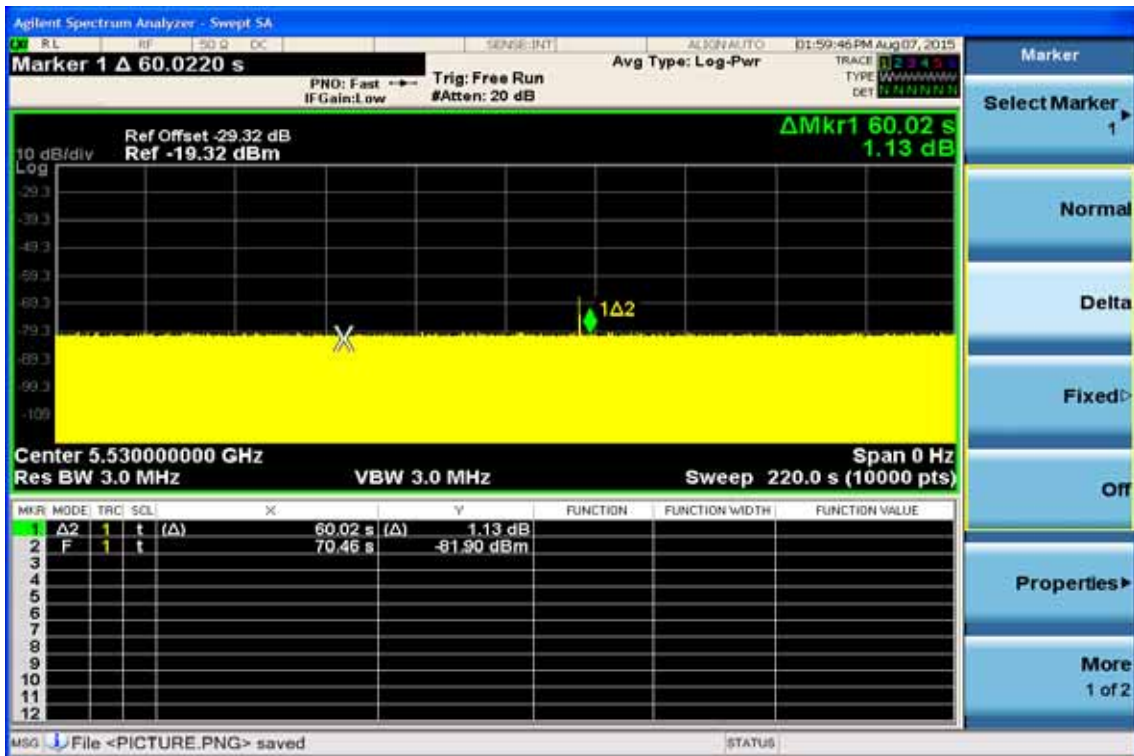

Type 3

Radar at the Begin of CAC

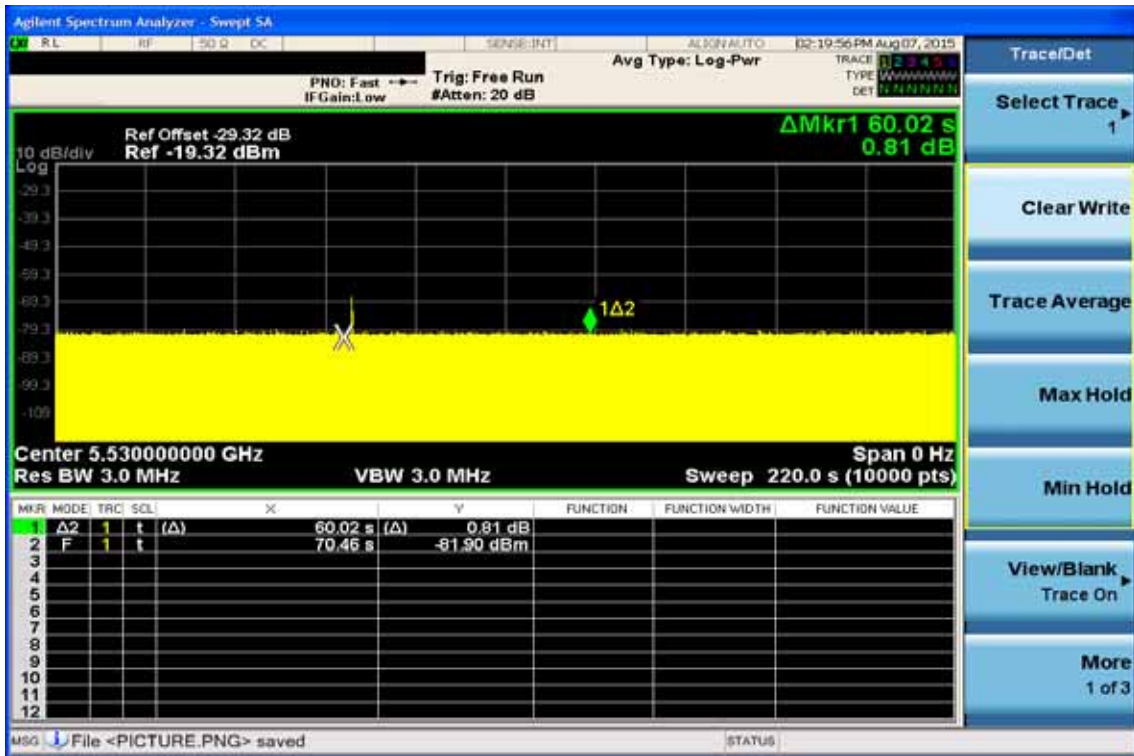

Radar at the Ending of CAC

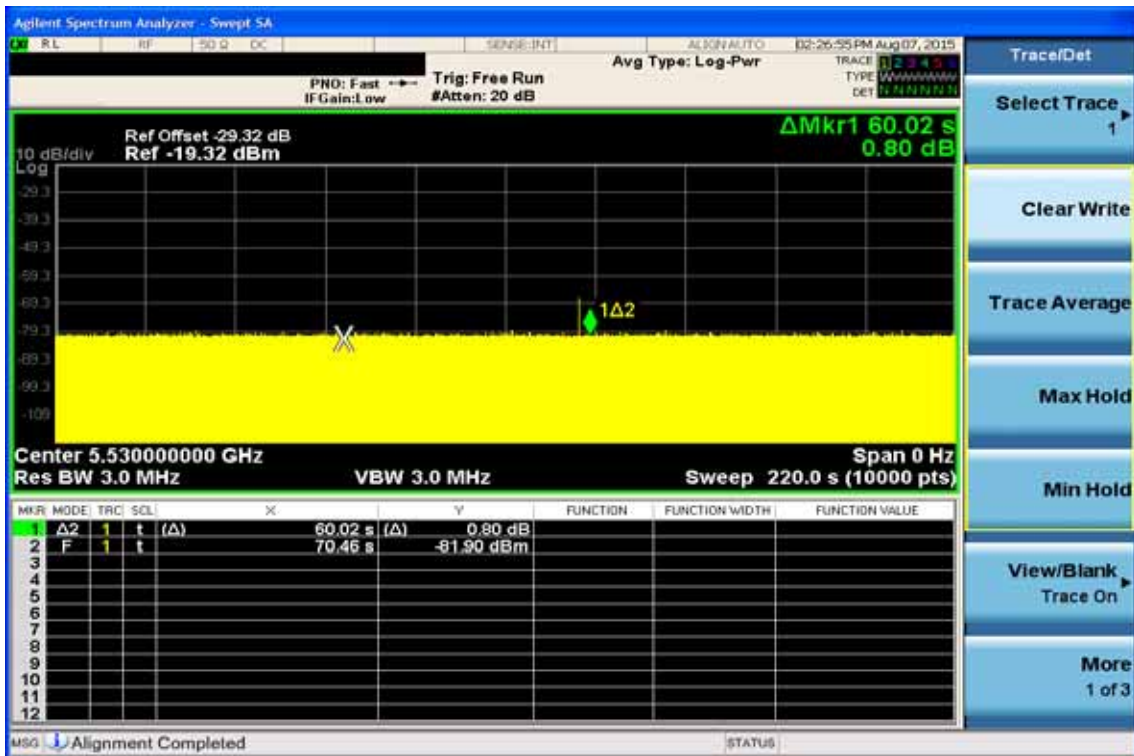

Type 4

Radar at the Begin of CAC

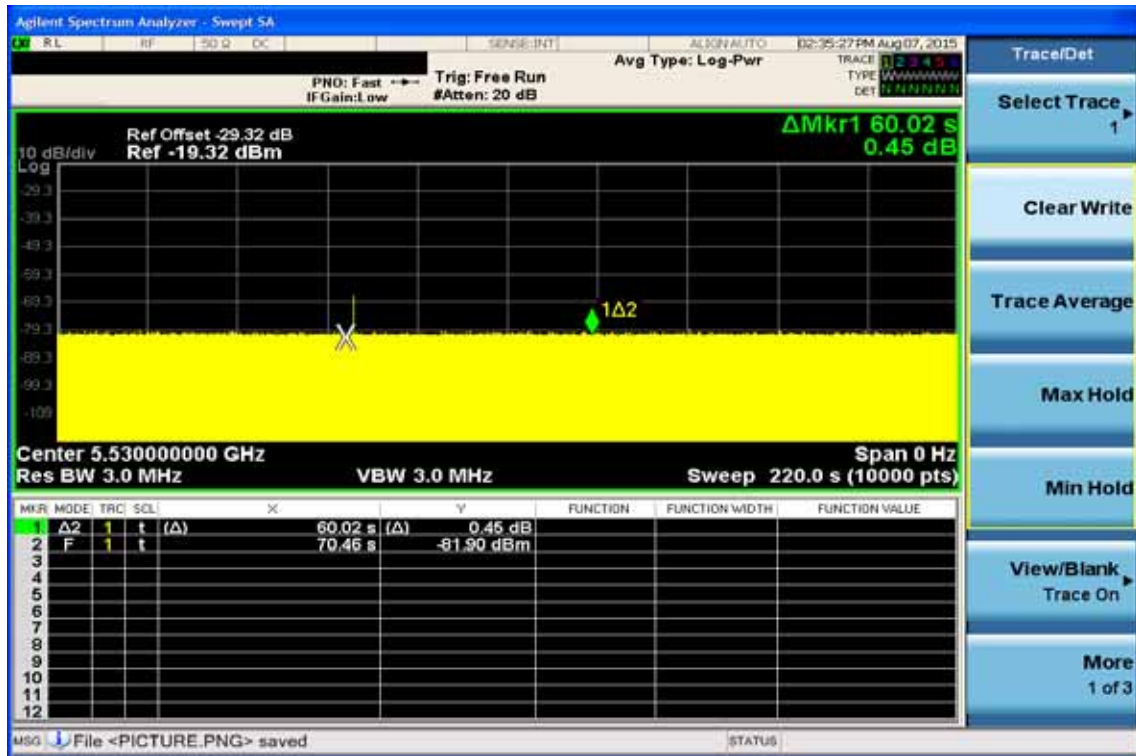

Radar at the Ending of CAC

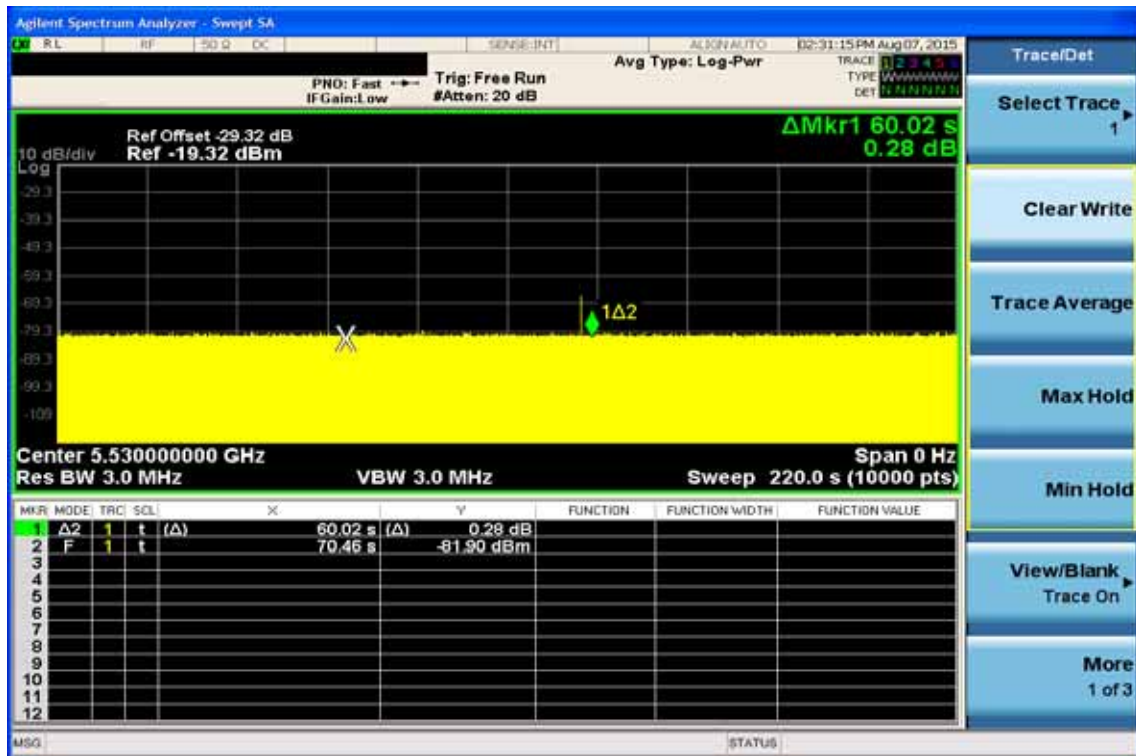

Type 5

Radar at the Begin of CAC

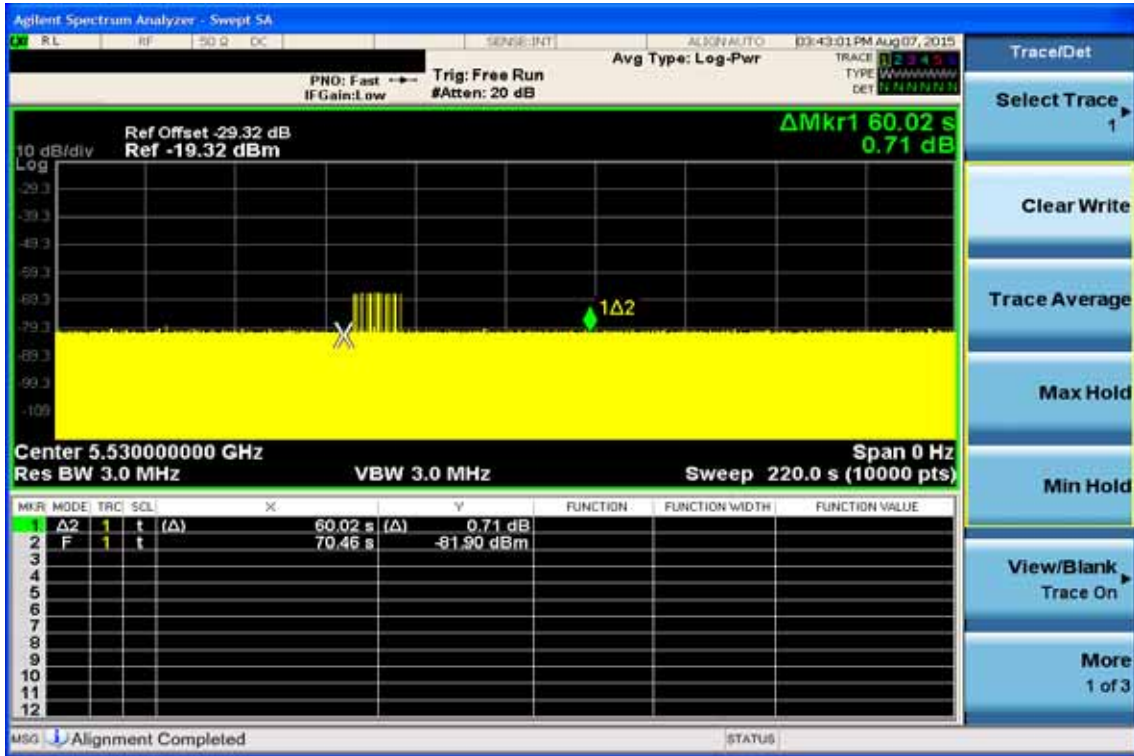

Radar at the Ending of CAC

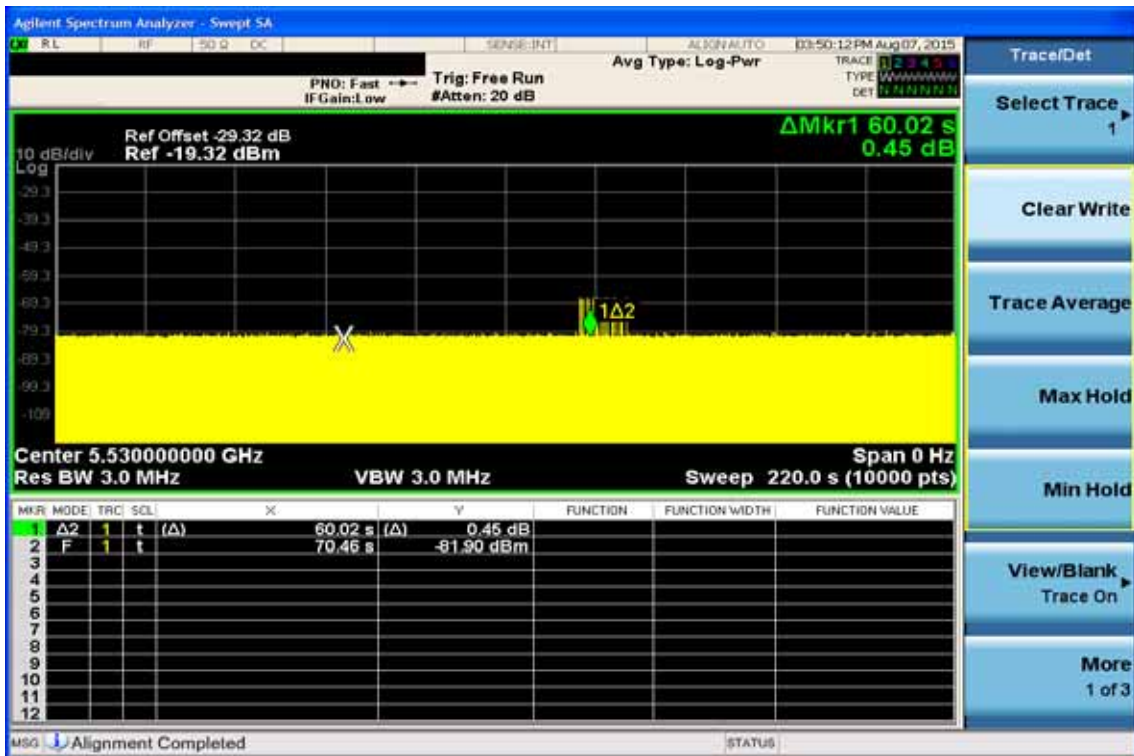

Type 6

Radar at the Begin of CAC

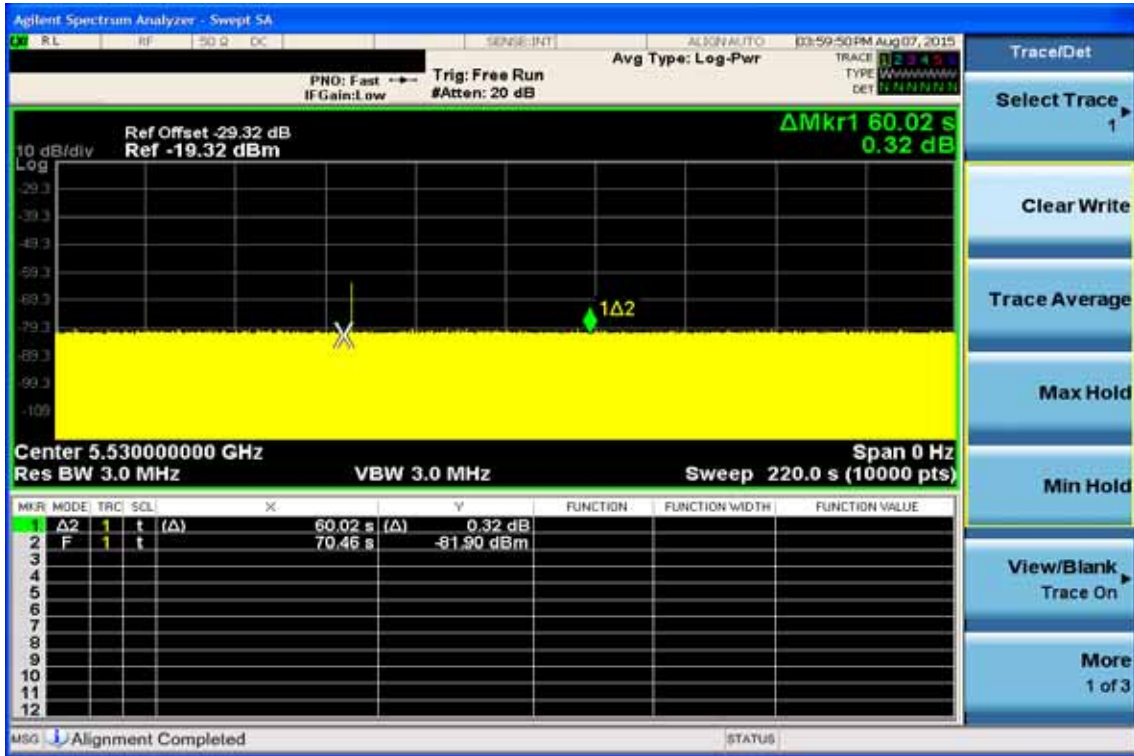

Radar at the Ending of CAC

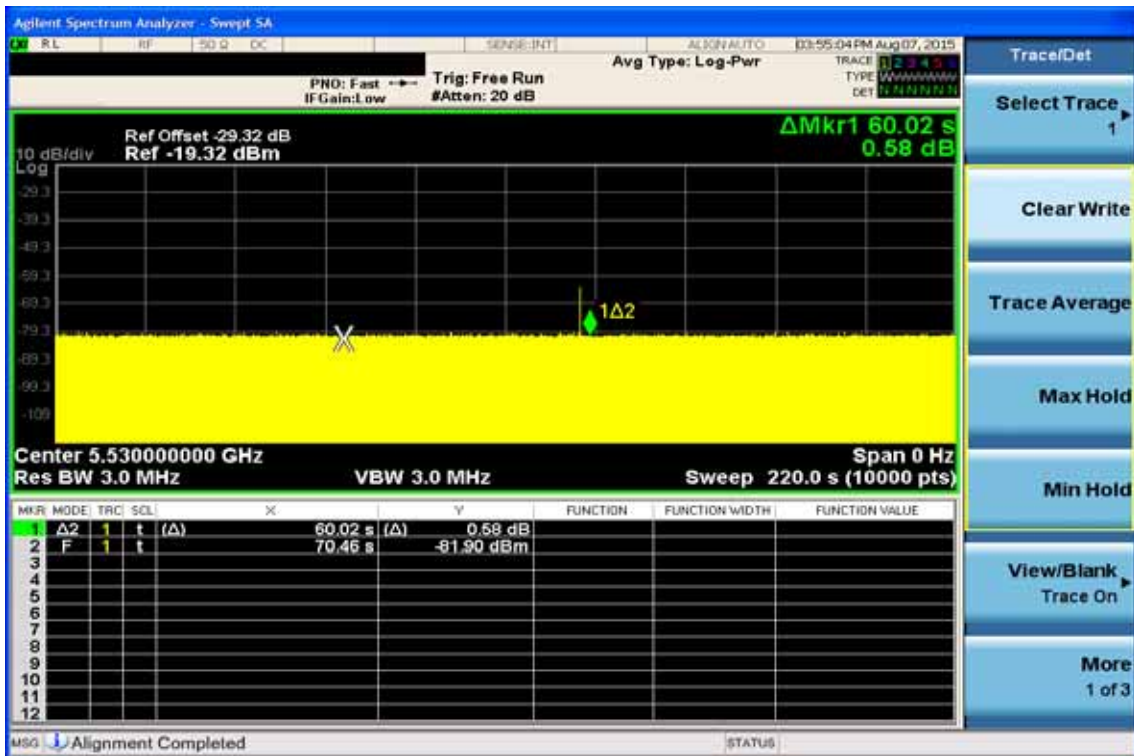

5290MHz Channel Move Time and Close time

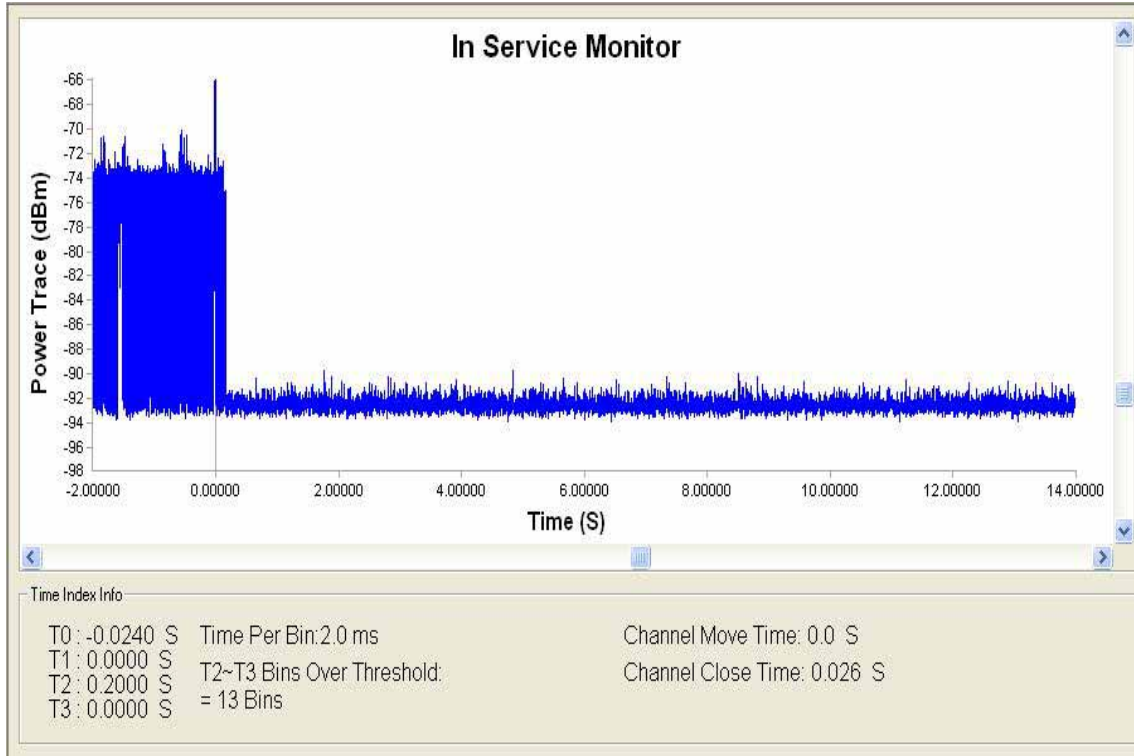

5290MHz Non-occupancy Period



5530MHz Channel Move Time and Close time

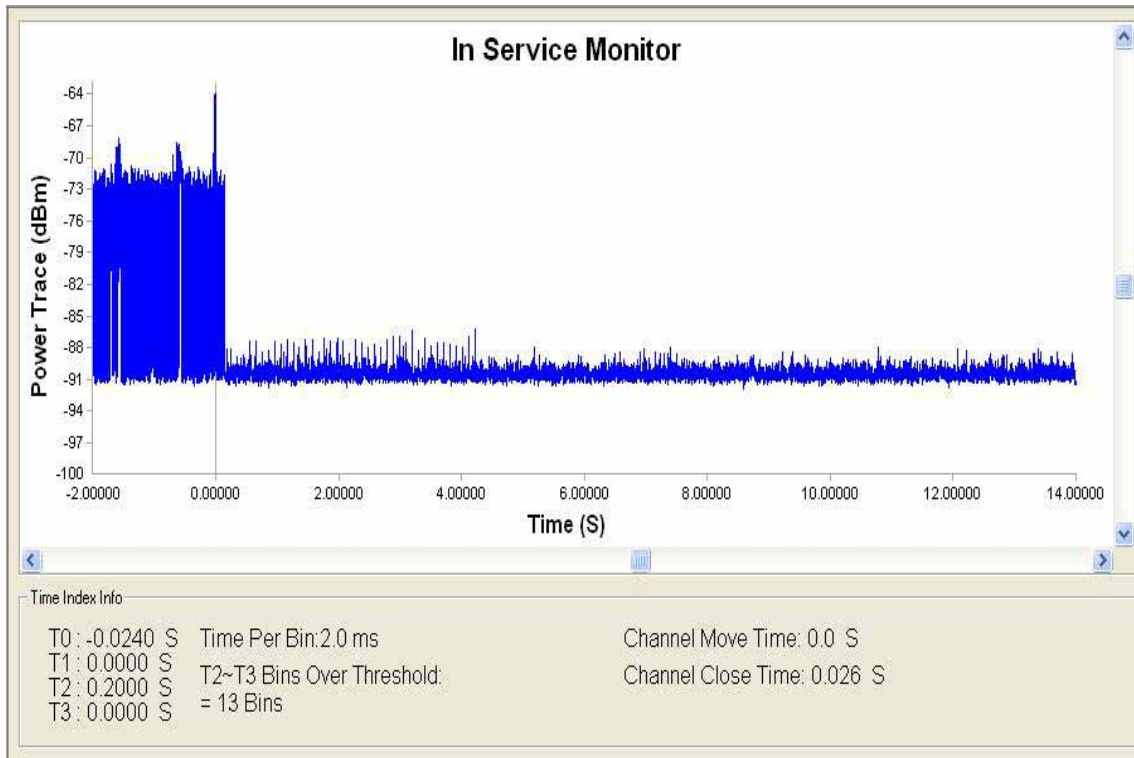

5530MHz Non-occupancy Period

