

# TEST REPORT

of

## FCC PART 15 SUBPART E

New Application;  Class I PC;  Class II PC

**Product :** Wireless Router  
**Brand:** Synology  
**Model:** RT1900ac  
**Model Difference:** N/A  
**FCC ID:** YOR-RT1900AC  
**FCC Rule Part:** §15.407, Cat:NII  
**Applicant:** Synology Incorporated  
**Address:** 3F-3,No.106,Chang An W. Rd., Taipei, Taiwan,  
R.O.C.

### Test Performed by:

#### International Standards Laboratory

<Lung-Tan LAB>

\*Site Registration No.

BSMI: SL2-IN-E-0013; MRA TW1036; TAF: 0997; IC: IC4067B-3;

\*Address:

No. 120, Lane 180, Hsin Ho Rd.

Lung-Tan Dist., Tao Yuan City 325, Taiwan

\*Tel : 886-3-407-1718; Fax: 886-3-407-1738

Report No.: **ISL-15LR055FENII**

Issue Date : **2015/05/11**



Test results given in this report apply only to the specific sample(s) tested and are traceable to national or international standard through calibration of the equipment and evaluating measurement uncertainty herein.

This report MUST not be used to claim product endorsement by TAF, NVLAP or any agency of the Government.

This test report shall not be reproduced except in full, without the written approval of International Standards Laboratory.

### VERIFICATION OF COMPLIANCE

**Applicant:** Synology Incorporated  
**Product Description:** Wireless Router  
**Brand Name:** Synology  
**Model No.:** RT1900ac  
**Model Difference:** N/A  
**FCC ID:** YOR-RT1900AC  
**FCC Rule Part:** §15.407, Cat: NII  
**Date of test:** 2015/03/13 ~ 2015/05/08  
**Date of EUT Received:** 2015/03/13

**We hereby certify that:**

All the tests in this report have been performed and recorded in accordance with the standards described above and performed by an independent electromagnetic compatibility consultant, International Standards Laboratory.

The test results contained in this report accurately represent the measurements of the characteristics and the energy generated by sample equipment under test at the time of the test. The sample equipment tested as described in this report is in compliance with the limits of above standards.

<b>Test By:</b>	 _____	<b>Date:</b>	2015/05/11 _____
	<i>Dion Chang / Engineer</i>		
<b>Prepared By:</b>	 _____	<b>Date:</b>	2015/05/11 _____
	<i>Gigi Yeh / Specialist</i>		
<b>Approved By:</b>	 _____	<b>Date:</b>	2015/05/11 _____
	<i>Vincent Su / Technical Manager</i>		

## Version

Version No.	Date	Description
00	2015/05/11	Initial creation of document

## Table of Contents

<b>1. GENERAL INFORMATION .....</b>	<b>6</b>
1.1. Product Description .....	6
1.2. Related Submittal(s) / Grant (s) .....	8
1.3. Test Methodology .....	8
1.4. Test Facility .....	8
1.5. Special Accessories .....	8
1.6. Equipment Modifications .....	8
<b>2. SYSTEM TEST CONFIGURATION .....</b>	<b>9</b>
2.1. EUT Configuration .....	9
2.2. EUT Exercise .....	9
2.3. Test Procedure .....	9
2.4. Configuration of Tested System .....	10
<b>3. SUMMARY OF TEST RESULT .....</b>	<b>11</b>
<b>4. DESCRIPTION OF TEST MODES .....</b>	<b>12</b>
<b>5. AC POWER LINE CONDUCTED EMISSION TEST .....</b>	<b>13</b>
5.1. Standard Applicable .....	13
5.2. Measurement Equipment Used: .....	13
5.3. EUT Setup: .....	14
5.4. Measurement Procedure: .....	14
5.5. Measurement Result: .....	14
<b>6. AVERAGE OUTPUT POWER / SPECTRAL DENSITY MEASUREMENT .....</b>	<b>17</b>
6.1 Standard Applicable .....	17
6.2 Measurement Procedure .....	19
6.3 Measurement Equipment Used: .....	20
6.4 Measurement Equipment Used: .....	20
6.5 Measurement Result .....	21
<b>7. 26dB /99% EMISSION BANDWIDTH MEASUREMENT .....</b>	<b>47</b>
7.1 Standard Applicable .....	47
7.2 Measurement Procedure .....	47
7.3 Measurement Equipment Used: .....	47
7.4 Test Set-up: .....	47
7.5 Measurement Result .....	48
<b>8. 6dB EMISSION BANDWIDTH MEASUREMENT .....</b>	<b>59</b>
8.1 Standard Applicable .....	59
8.2 Measurement Procedure .....	59
8.3 Measurement Equipment Used: .....	59
8.4 Test Set-up: .....	59
8.5 Measurement Result .....	60

<b>9. UNDESIRABLE EMISSION - RADICTED MEASUREMENT .....</b>	<b>66</b>
9.1 Standard Applicable .....	66
9.2 EUT Setup.....	68
9.3 Measurement Procedure.....	69
9.4 Test SET-UP (Block Diagram of Configuration).....	70
9.5 Measurement Equipment Used: .....	71
9.6 Field Strength Calculation .....	72
9.7 Measurement Result.....	72
<b>10. TRANSMISSION IN THE ABSENCE OF DATA .....</b>	<b>87</b>
10.1 Standard Applicable .....	87
10.2 Result: .....	87
<b>11. FREQUENCY STABILITY .....</b>	<b>88</b>
11.1 Standard Applicable .....	88
11.2 Result: .....	88
<b>12. ANTENNA REQUIREMENT .....</b>	<b>89</b>
12.1 Standard Applicable .....	89
12.2 Antenna Connected Construction .....	89

## 1. GENERAL INFORMATION

### 1.1. Product Description

General:

Product Name	Wireless Router	
Brand Name	Synology	
Model Name	RT1900ac	
Model Difference	N/A	
TPC	Yes	
DFS	Non-DFS frequency bands	
Simultaneous transmissions:	Yes, 2.4GHz and 5GHz	
WAN Port:	One provided	
LAN Port:	Four provided, 10/100/1000Mbps	
Power Supply	12Vdc from AC adapter	
	Adapter:	Model: WA-24E12

The device is an indoor access point.

WLAN: 3X3 MIMO

Wi-Fi	Frequency Range (MHz)	Channels	Peak / Average Rated Power	Modulation Technology
802.11b	2412 – 2462(DTS)	11	19.21dBm (PK)	DSSS
802.11g	2412 – 2462(DTS)	11	24.91dBm (PK)	OFDM
802.11n (2.4G)	HT20 2412 – 2462(DTS)	11	24.87dBm (PK)	
	HT40 2422 – 2452(DTS)	7	25.49dBm (PK)	

WLAN: 3X3 MIMO

802.11a	5170 - 5240(NII)	8	7.97dBm (AVG)	OFDM	
802.11an	HT20 5170 - 5240(NII)	8	12.55dBm (AVG)		
	HT40 5190 - 5230(NII)	2	11.54dBm (AVG)		
802.11ac	5210(NII)	1	10.70dBm (AVG)		
802.11a	5745 - 5825(NII)	5	8.64dBm (AVG)		
802.11an	HT20 5745 - 5825(NII)	5	13.83dBm (AVG)		
	HT40 5755 - 5795(NII)	2	13.11dBm (AVG)		
802.11ac	5775(NII)	1	12.32dBm (AVG)		
Modulation type		CCK, DQPSK, DBPSK for DSSS 256QAM.64QAM. 16QAM, QPSK, BPSK for OFDM			
Antenna Designation		Reversed SMA type dipole antenna : 3.63 dBi(2.4G) 、6.12dBi(5G)  According to KDB662911 D01 MU-MIMO signals could be considered uncorrelated for purposes of direc- tional gain computation. 3Tx MIMO, Beamforming gain:4.77dBi = 10log(3)			

Power Tolerance: 2 dB

The EUT is compliance with IEEE 802.11 a/b/g/n/ac Standard.

This report applies for Wifi frequency band 5150 MHz– 5250 MHz, 5725 MHz– 5850 MHz

**Remark:** The above DUT's information was declared by manufacturer. Please refer to the specifications or user's manual for more detailed description.

## 1.2. Related Submittal(s) / Grant (s)

This submittal(s) (test report) is intended for **FCC ID: YOR-RT1900AC** filing to comply with Section 15.407 of the FCC Part 15, Subpart E Rules. The composite system (digital device) is compliance with Subpart B is authorized under a DoC procedure.

## 1.3. Test Methodology

Both conducted and radiated testing were performed according to the procedures in ANSI C63.4: 2014, ANSI C63.10: 2013. Radiated testing was performed at an antenna to EUT distance 3 meters.

KDB Document: 789033 D02 General UNII Test Procedures New Rules v01

FCC 14-30 Revision UNII

594280 D02 U-NII Device Security v01r02

## 1.4. Test Facility

The measurement facilities used to collect the 3m Radiated Emission and AC power line conducted data are located on the address of International Standards Laboratory <Lung-Tan LAB> No. 120, Lane 180, Hsin Ho Rd., Lung-Tan Dist., Tao Yuan City 325, Taiwan which are constructed and calibrated to meet the FCC requirements in documents ANSI C63.4: 2014, ANSI C63.10: 2013. FCC Registration Number is: 872200; Designation Number is: TW1036, Canada Registration Number: 4067B-3.

## 1.5. Special Accessories

Not available for this EUT intended for grant.

## 1.6. Equipment Modifications

Not available for this EUT intended for grant.



## 2. SYSTEM TEST CONFIGURATION

### 2.1. EUT Configuration

The EUT configuration for testing is installed on RF field strength measurement to meet the Commissions requirement and operating in a manner which intends to maximize its emission characteristics in a continuous normal application.

### 2.2. EUT Exercise

The EUT (Transmitter) was operated in the engineering mode to fix the Tx frequency that was for the purpose of the measurements.

### 2.3. Test Procedure

#### 2.3.1 Conducted Emissions

The EUT is a placed on as turn table which is 0.8 m above ground plane. According to the requirements in Section Section 5 and 7 of ANSI C63.4: 2014. Conducted emissions from the EUT measured in the frequency range between 0.15 MHz and 30 MHz using CISPR Quasi-Peak and Average detector mode.

#### 2.3.2 Radiated Emissions

The EUT is a placed on as turn table which is 0.8 m /1.5m(Frequency above 1GHz) above ground plane. The turn table shall rotate 360 degrees to determine the position of maximum emission level. EUT is set 3m away from the receiving antenna which varied from 1m to 4m to find out the highest emission. And also, each emission was to be maximized by changing the polarization of receiving antenna both horizontal and vertical. In order to find out the max. emission, the relative positions of this hand-held transmitter (EUT) was rotated through three orthogonal axes and measurement procedures for electric field radiated emissions above 1 GHz the EUT measurement is to be made “while keeping the antenna in the ‘cone of radiation’ from that area and pointed at the area both in azimuth and elevation, with polarization oriented for maximum response.” Is still within the 3Db illumination BW of the measurement antenna. According to the requirements in Section 6 and 11 of ANSI C63.10: 2013.

## 2.4. Configuration of Tested System

**Fig. 2-1 Configuration of Tested System**

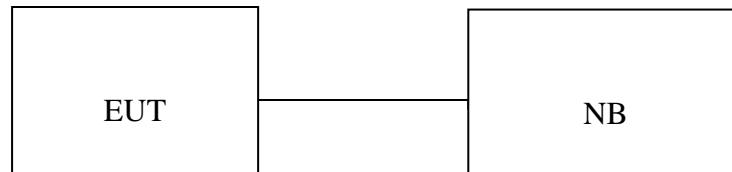

**Table 1-1 Equipment Used in Tested System**

Item	Equipment	Mfr/Brand	Model/ Type No.	Series No.	Data Cable	Power Cord
1	NB	HP	440	N/A	N/A	No- Shielding

### 3. SUMMARY OF TEST RESULT

<b>FCC Rules</b>	<b>Description Of Test</b>	<b>Result</b>
§15.207	AC Power Line Conducted Emission	Compliant
§15.407(a)	26dB/99% Emission Bandwidth	Compliant
§15.407(e)	6dB Emission Bandwidth	Compliant
§15.407(a)(2)	Average Output Power/ Spectral Density Measurement	Compliant
§15.407(b)	Undesirable Emission – Conducted Measurement	Compliant
§15.407(b)	Undesirable Emission – Radiated Measurement	Compliant
§15.407( c)	Transmission in case of Absence of Information	Compliant
§15.407(g)	Frequency Stability	Compliant
§15.407(a)	Antenna Requirement	Compliant
§15.407(d)	TPC and DFS Measurement	N/A
§15.407(i)	Device Security	Compliant

#### 4. DESCRIPTION OF TEST MODES

The EUT has been tested under operating condition.

Test program used to control the EUT for staying in continuous transmitting mode is programmed.

##### **5150MHz-5250MHz:**

a mode: Channel lowest (5170MHz) 、Mid (5200MHz) and Highest (5240MHz) with 6Mbps data rate are chosen for full testing.

802.11 n HT20: Channel lowest (5170MHz) 、Mid (5200MHz) and Highest (5240MHz) with 6.5Mbps data rate are chosen for full testing

802.11 n HT40: Channel lowest (5190MHz) 、Highest (5230MHz) with 13.5Mbps data rate are chosen for full testing

802.11 AC HT80: Channel (5210MHz) with 29.3Mbps lowest data rate is chosen for pre-test testing of radiated emissions.

The worst case 802.11 n HT20 (5GHz) was reported for Radiated Emission.

##### **5725MHz-5850MHz:**

802.11a mode: Channel low (5745MHz) 、mid (5785MHz) and high (5825MHz) with 6Mbps lowest data rate are chosen for pre-test testing of radiated emissions.

802.11 n HT20: Channel low (5745MHz) 、mid (5785MHz) and high (5825MHz) with 6.5Mbps lowest data rate are chosen for pre-test testing of radiated emissions.

802.11 n HT40: Channel low (5755MHz) and high (5795MHz) with 13.5Mbps lowest data rate are chosen for pre-test testing of radiated emissions.

802.11 AC HT80: Channel (5775MHz) with 29.3Mbps lowest data rate is chosen for pre-test testing of radiated emissions.

The worst case 802.11 n HT20 (5GHz) was reported for Radiated Emission.

## 5. AC POWER LINE CONDUCTED EMISSION TEST

### 5.1. Standard Applicable

According to §15.207, frequency range within 150 KHz to 30 MHz shall not exceed the Limit table as below.

Frequency range MHz	Limits dB(uV)	
	Quasi-peak	Average
0.15 to 0.50	66 to 56	56 to 46
0.50 to 5	56	46
5 to 30	60	50

Note

- 1.The lower limit shall apply at the transition frequencies
- 2.The limit decreases linearly with the logarithm of the frequency in the range 0.15 MHz to 0.50 MHz.

### 5.2. Measurement Equipment Used:

Conducted Emission Test Site					
EQUIPMENT TYPE	MFR	MODEL NUMBER	SERIAL NUMBER	LAST CAL.	CAL DUE.
Conduction 04-3 Cable	WOKEN	CFD 300-NL	Conduction 04 -3	07/24/2014	07/23/2015
EMI Receiver 17	Rohde & Schwarz	ESCI 7	100887	09/03/2014	09/02/2015
LISN 18	ROHDE & SCHWARZ	ENV216	101424	02/11/2015	02/10/2016
LISN 19	ROHDE & SCHWARZ	ENV216	101425	03/12/2015	03/11/2016

### **5.3. EUT Setup:**

1. The conducted emission tests were performed in the test site, using the setup in accordance with the ANSI C63.4-2014.
2. The AC/DC Power adaptor of EUT was plug-in LISN. The EUT was placed flushed with the rear of the table.
3. The LISN was connected with 120Vac/60Hz power source.

### **5.4. Measurement Procedure:**

1. The EUT was placed on a table which is 0.8m above ground plane.
2. Maximum procedure was performed on the six highest emissions to ensure EUT compliance.
3. Repeat above procedures until all frequency measured were complete.

### **5.5. Measurement Result:**

The initial step in collecting conducted data is a spectrum analyzer peak scan of the measurement range. Significant peaks are then marked as shown on the following data page, and these signals are then quasi-peaked.

Note: Refer to next page for measurement data and plots.

### AC POWER LINE CONDUCTED EMISSION TEST DATA

Operation Mode:	Operation Mode	Test Date:	2015/04/13
Test By:	Dino		



Address: No. 120, Lane 180, Hsin Ho Rd., Lung-Tan Dist.,  
Tao Yuan City 325, Taiwan.  
Tel: 03-4071718

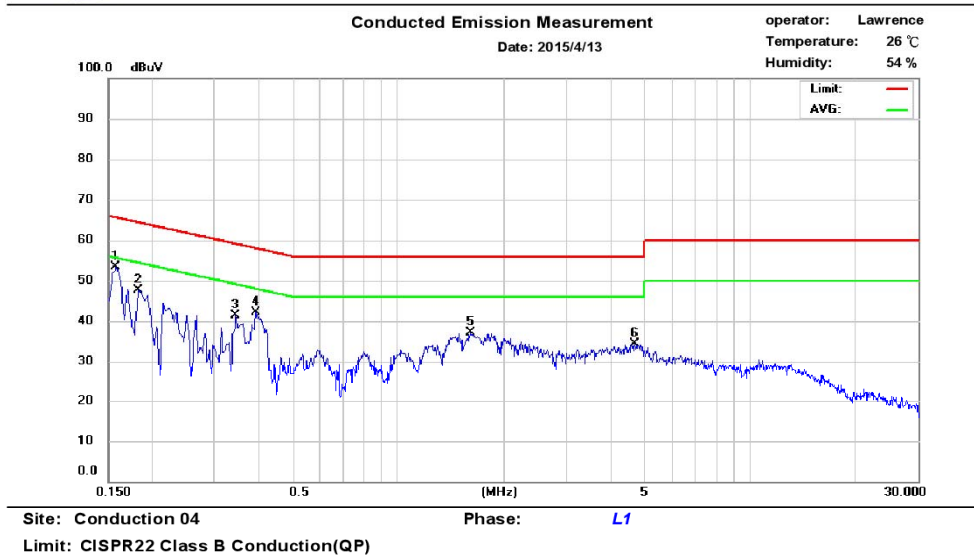

No.	Frequency (MHz)	QP_R (dBuV)	AVG_R (dBuV)	Correct Factor (dB)	QP Emission (dBuV)	QP Limit (dBuV)	QP Margin (dB)	AVG Emission (dBuV)	AVG Limit (dBuV)	AVG Margin (dB)
1	0.158	41.96	28.92	9.63	51.59	65.57	-13.98	38.55	55.57	-17.02
2	0.182	34.93	16.24	9.61	44.54	64.39	-19.85	25.85	54.39	-28.54
3	0.346	29.32	20.99	9.60	38.92	59.06	-20.14	30.59	49.06	-18.47
4	0.394	29.88	20.06	9.61	39.49	57.98	-18.49	29.67	47.98	-18.31
5	1.602	25.28	17.46	9.67	34.95	56.00	-21.05	27.13	46.00	-18.87
6	4.702	21.27	13.78	9.75	31.02	56.00	-24.98	23.53	46.00	-22.47



Address: No. 120, Lane 180, Hsin Ho Rd., Lung-Tan Dist.,  
Tao Yuan City 325, Taiwan.  
Tel: 03-4071718

Conducted Emission Measurement

Date: 2015/4/13

operator: Lawrence

Temperature: 26 °C

Humidity: 54 %

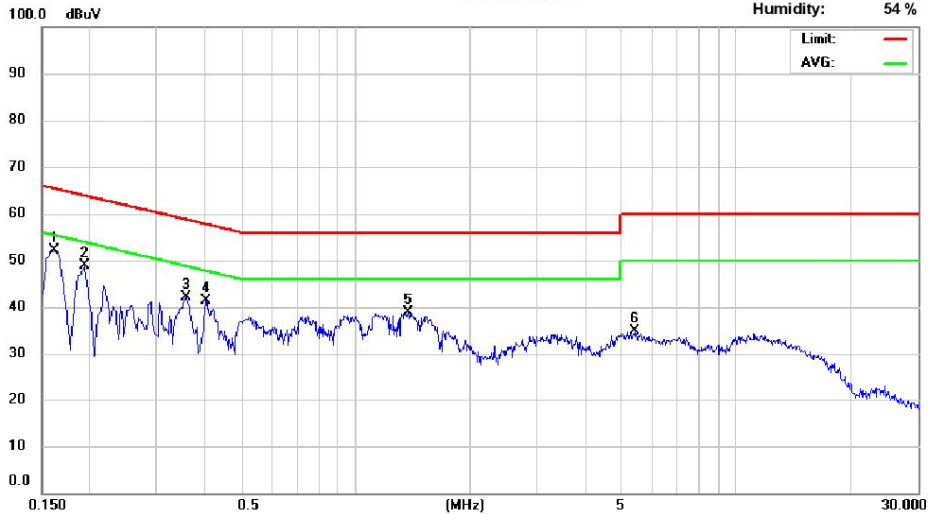

Site: Conduction 04

Phase: N

Limit: CISPR22 Class B Conduction(QP)

No.	Frequency (MHz)	QP_R (dBuV)	AVG_R (dBuV)	Correct Factor (dB)	QP Emission (dBuV)	QP Limit (dBuV)	QP Margin (dB)	AVG Emission (dBuV)	AVG Limit (dBuV)	AVG Margin (dB)
1	0.162	40.92	27.55	9.62	50.54	65.36	-14.82	37.17	55.36	-18.19
2	0.194	35.62	21.61	9.62	45.24	63.86	-18.62	31.23	53.86	-22.63
3	0.358	30.90	21.69	9.62	40.52	58.77	-18.25	31.31	48.77	-17.46
4	0.406	29.74	21.37	9.62	39.36	57.73	-18.37	30.99	47.73	-16.74
5	1.374	27.48	19.69	9.66	37.14	56.00	-18.86	29.35	46.00	-16.65
6	5.446	21.29	14.06	9.79	31.08	60.00	-28.92	23.85	50.00	-26.15



## 6. AVERAGE OUTPUT POWER / SPECTRAL DENSITY MEASUREMENT

### 6.1 Standard Applicable

According to §15.407(a) Power limits:

(1) For the band 5.15-5.25 GHz.

(i) For an outdoor access point operating in the band 5.15 – 5.25 GHz, the maximum conducted output power over the frequency band of operation shall not exceed 1 W provided the maximum antenna gain does not exceed 6 dBi. In addition, the maximum power spectral density shall not exceed 17 dBm in any 1 megahertz band. If transmitting antennas of directional gain greater than 6 dBi are used, both the maximum conducted output power and the maximum power spectral density shall be reduced by the amount in dB that the directional gain of the antenna exceeds 6 dBi. The maximum e.i.r.p. at any elevation angle above 30 degrees as measured from the horizon must not exceed 125 mW (21 dBm).

(ii) For an indoor access point operating in the band 5.15 – 5.25 GHz, the maximum conducted output power over the frequency band of operation shall not exceed 1 W provided the maximum antenna gain does not exceed 6 dBi. In addition, the maximum power spectral density shall not exceed 17 dBm in any 1 megahertz band. If transmitting antennas of directional gain greater than 6 dBi are used, both the maximum conducted output power and the maximum power spectral density shall be reduced by the amount in dB that the directional gain of the antenna exceeds 6 dBi.

(iii) For fixed point-to-point access points operating in the band 5.15 – 5.25 GHz, the maximum conducted output power over the frequency band of operation shall not exceed 1 W. Fixed point-to-point U-NII devices may employ antennas with directional gain up to 23 dBi without any corresponding reduction in the maximum conducted output power or maximum power spectral density. For fixed point-to-point transmitters that employ a directional antenna gain greater than 23 dBi, a 1 dB reduction in maximum conducted output power and maximum power spectral density is required for each 1 dB of antenna gain in excess of 23 dBi. Fixed, point-to-point operations exclude the use of point-to-multipoint systems, omnidirectional applications, and multiple collocated transmitters transmitting the same information. The operator of the U-NII device, or if the equipment is professionally installed, the installer, is responsible for ensuring that systems employing high gain directional antennas are used exclusively for fixed, point-to-point operations.

(iv) For mobile and portable client devices in the 5.15 – 5.25 GHz band, the maximum conducted output power over the frequency band of operation shall not exceed 250 mW provided the maximum antenna gain does not exceed 6 dBi. In addition, the maximum power spectral density shall not exceed 11 dBm in any 1 megahertz band. If transmitting antennas of directional gain greater than 6 dBi are used, both the maximum conducted output power and the maximum power spectral density shall be reduced by the amount in dB that the directional gain of the antenna exceeds 6 dBi.

(2) For the 5.25-5.35 GHz and 5.47-5.725 GHz bands, the maximum conducted output power over the frequency bands of operation shall not exceed the lesser of 250 mW or  $11 \text{ dBm} + 10 \log B$ , where B is the 26 dB emission bandwidth in megahertz. In addition, the maximum power spectral density shall not exceed 11 dBm in any 1 megahertz band. If transmitting antennas of directional gain greater than 6 dBi are used, both the maximum conducted output power and the maximum power spectral density shall be reduced by the amount in dB that the directional gain of the antenna exceeds 6 dBi.

(3) For the band 5.725-5.85 GHz, the maximum conducted output power over the frequency band of operation shall not exceed 1 W. In addition, the maximum power spectral density shall not exceed 30 dBm in any 500 kHz band. If transmitting antennas of directional gain greater than 6 dBi are used, both the maximum conducted output power and the maximum power spectral density shall be reduced by the amount in dB that the directional gain of the antenna exceeds 6 dBi. However, fixed point-to-point U-NII devices operating in this band may employ transmitting antennas with directional gain greater than 6 dBi without any corresponding reduction in transmitter conducted power. Fixed, point-to-point operations exclude the use of point-to-multipoint systems, omnidirectional applications, and multiple collocated transmitters transmitting the same information. The operator of the U-NII device, or if the equipment is professionally installed, the installer, is responsible for ensuring that systems employing high gain directional antennas are used exclusively for fixed, point-to-point operations.

NOTE TO PARAGRAPH ( a )(3): The Commission strongly recommends that parties employing U-NII devices to provide critical communications services should determine if there are any nearby Government radar systems that could affect their operation.

## 6.2 Measurement Procedure

For Average Power

1. Place the EUT on the table and set it in transmitting mode.
2. Remove the antenna from the EUT and then connect a low loss RF cable from the antenna port to the power meter
3. Record the max. reading.
4. Repeat above procedures until all frequency measured were complete.

For Peak Power Spectral Density

1. Place the EUT on the table and set it in transmitting mode.
2. Remove the antenna from the EUT and then connect a low loss RF cable from the antenna port to Spectrum.
3. Set RBW=1MHz,VBW=3MHz, Span=50MHz (Base Mode), Sweep time = Auto, traces 100 sweeps of video averaging for 5150-5725MHz;
4. Set RBW=500KHz,VBW=1.5MHz, Span=60MHz (Base Mode), Sweep time = Auto, traces 100 sweeps of video averaging for 5725-5850MHz;
5. Record the max. reading.
6. Repeat above procedures until all frequency measured were complete.

**Refer to section E3 of KDB Document: KDB 789033 D02 General UNII Test Procedures New Rules v01**

### 6.3 Measurement Equipment Used:

Conducted Emission Test Site					
EQUIPMENT TYPE	MFR	MODEL NUMBER	SERIAL NUMBER	LAST CAL.	CAL DUE.
Power Meter 05	Anritsu	ML2495A	1116010	05/08/2015	05/07/2016
Power Sensor 05	Anritsu	MA2411B	34NKF50	05/08/2015	05/07/2016
Power Sensor 06	DARE	RPR3006W	13I00030SN O33	10/31/2014	10/30/2015
Power Sensor 07	DARE	RPR3006W	13I00030SN O34	10/31/2014	10/30/2015
Temperature Chamber	KSON	THS-B4H100	2287	03/17/2015	03/16/2016
DC Power supply	ABM	8185D	N/A	07/16/2014	07/15/2015
AC Power supply	EXTECH	CFC105W	NA	12/27/2014	12/26/2015
Attenuator	Woken	Watt-65m3502	11051601	NA	NA
Splitter	MCLI	PS4-199	12465	12/27/2013	12/26/2015
Spectrum analyzer	Agilent	N9030A	MY51360021	05/02/2015	05/01/2016

### 6.4 Measurement Equipment Used:

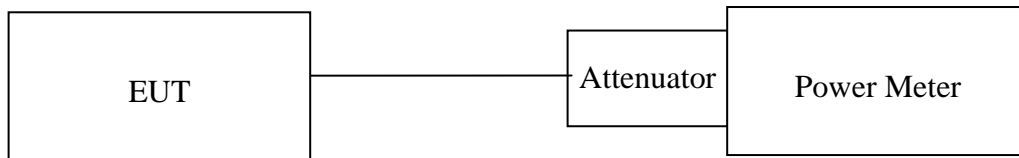

## 6.5 Measurement Result

**Band: 5150-5250 MHz**

**Average Power Measurement:**

802.11a

Mode	Freq(MHz)	channel	AV power (dBm)	limit(dBm)	result
802.11a	5170	34	7.70	29.88	pass
	5200	40	7.97	29.88	pass
	5240	48	7.54	29.88	pass

3\*3 MIMO

Mode	Freq(MHz)	channel	Output Chain (dBm)			Combine Output Power (dBm)	Limit(dBm)	Result
			Chain A	chain B	Chain C			
N HT20	5170	34	7.25	7.57	7.66	12.27	29.88	Pass
	5200	40	8.32	7.00	7.92	12.55	29.88	Pass
	5240	48	8.27	6.78	7.54	12.34	29.88	Pass

Mode	Freq(MHz)	channel	Output Chain (dBm)			Combine Output Power (dBm)	Limit(dBm)	Result
			Chain A	chain B	Chain C			
N HT40	5190	36	6.95	6.00	7.25	11.54	29.88	Pass
	5230	44	7.45	5.50	7.03	11.51	29.88	Pass

Mode	Freq(MHz)	channel	Output Chain (dBm)			Combine Output Power (dBm)	Limit(dBm)	Result
			Chain A	chain B	Chain C			
AC HT80	5210	48	5.77	5.19	6.70	10.70	29.88	Pass

Note: 1. offset 0.5 dB for cable loss.

2. 5GHz antenna gain is 6.12dBi, the limit is reduced 0.12 dB.

**Peak Power Spectral Density Measurement:**

802.11a Mode

Frequency MHz	RF Power Density Reading (dBm/1MHz)	Cable loss (dB)	Maximum Limit (dBm/1MHz)
5170	6.850	0.00	16.88
5200	6.880	0.00	16.88
5240	7.190	0.00	16.88

3\*3 MIMO

802.11n HT20

Frequency MHz	Chain 1 RF Power Density	Chain 2 RF Power Density	Chain 3 RF Power Density	Cable loss (dB)	RF Power Density Level (dBm/1MHz)	Maximum Limit (dBm/1MHz)
	Reading (dBm)	Reading (dBm)	Reading (dBm)			
5170	5.920	5.890	5.210	0.00	10.457	16.88
5200	5.090	5.670	5.970	0.00	10.363	16.88
5240	6.110	5.880	6.000	0.00	10.769	16.88

802.11n HT40 Mode

Frequency MHz	Chain 1 RF Power Density	Chain 2 RF Power Density	Chain 3 RF Power Density	Cable loss (dB)	RF Power Density Level (dBm/1MHz)	Maximum Limit (dBm/1MHz)
	Reading (dBm)	Reading (dBm)	Reading (dBm)			
5190	3.050	2.800	2.950	0.00	7.706	16.88
5230	3.510	3.190	2.800	0.00	7.948	16.88

802.11AC HT80 Mode

Frequency MHz	Chain 1 RF Power Density	Chain 2 RF Power Density	Chain 3 RF Power Density	Cable loss (dB)	RF Power Density Level (dBm/1MHz)	Maximum Limit (dBm/1MHz)
	Reading (dBm)	Reading (dBm)	Reading (dBm)			
5210	0.050	-0.860	-0.920	0.00	4.218	16.88

Note: 1. offset 0.5 dB for cable loss.

2. 5GHz antenna gain is 6.12dBi, the limit is reduced 0.12 dB.

**Band: 5725-5850 MHz**

**Average Power Measurement:**

802.11a

Mode	Freq(MHz)	channel	AV Power (dBm)	limit(dBm)	result
802.11a	5745	149	8.45	29.88	pass
	5785	157	8.35	29.88	pass
	5825	165	8.64	29.88	pass

3\*3 MIMO

802.11n HT20

Mode	Freq(MHz)	channel	Output Chain (dBm)			Combine Output Power (dBm)	Limit(dBm)	Result
			Chain A	chain B	Chain C			
N HT20	5745	149	9.98	9.21	7.70	13.83	29.88	Pass
	5785	157	9.92	9.05	7.53	13.71	29.88	Pass
	5825	165	9.85	8.54	7.49	13.51	29.88	Pass

802.11n H40

Mode	Freq(MHz)	channel	Output Chain (dBm)			Combine Output Power (dBm)	Limit(dBm)	Result
			Chain A	chain B	Chain C			
N HT40	5755	151	8.37	8.38	8.03	13.03	29.88	Pass
	5795	163	8.62	8.31	8.07	13.11	29.88	Pass

802.11AC HT80

Mode	Freq(MHz)	channel	Output Chain (dBm)			Combine Output Power (dBm)	Limit(dBm)	Result
			Chain A	chain B	Chain C			
AC HT80	5775	155	7.58	7.61	7.45	12.32	29.88	Pass

Note: 1. offset 0.5 dB for cable loss.

2. 5GHz antenna gain is 6.12dBi, the limit is reduced 0.12 dB.

**Peak Power Spectral Density Measurement:**

**802.11a Mode**

Frequency MHz	Power Density Level (dBm/1MHz)	Maximum Limit (dBm/500KHz)
5745	7.370	29.88
5785	7.520	29.88
5825	7.180	29.88

**3\*3 MIMO**

	Frequency (MHz)	Output Chain dbm			Combine Power Density (dBm/1MHz)	Limit(dBm) (dBm/500kHz)	Result
		Chain A	chain B	Chain C			
AN HT20	5745	8.140	6.250	5.700	11.60	29.88	Pass
	5785	8.250	6.220	5.750	11.65	29.88	Pass
	5825	7.480	6.320	5.180	11.20	29.88	Pass
AN HT40	5755	2.710	2.440	1.650	7.06	29.88	Pass
	5795	4.330	2.840	1.820	7.89	29.88	Pass
AC HT80	5775	0.490	-1.000	-2.110	4.03	29.88	Pass

Note: 1. offset 0.5 dB for cable loss.

2. 5GHz antenna gain is 6.12dBi, the limit is reduced 0.12 dB.



**5150-5250 MHz**

**802.11a**

**Peak Power Spectral Density Data Plot (CH Low)**

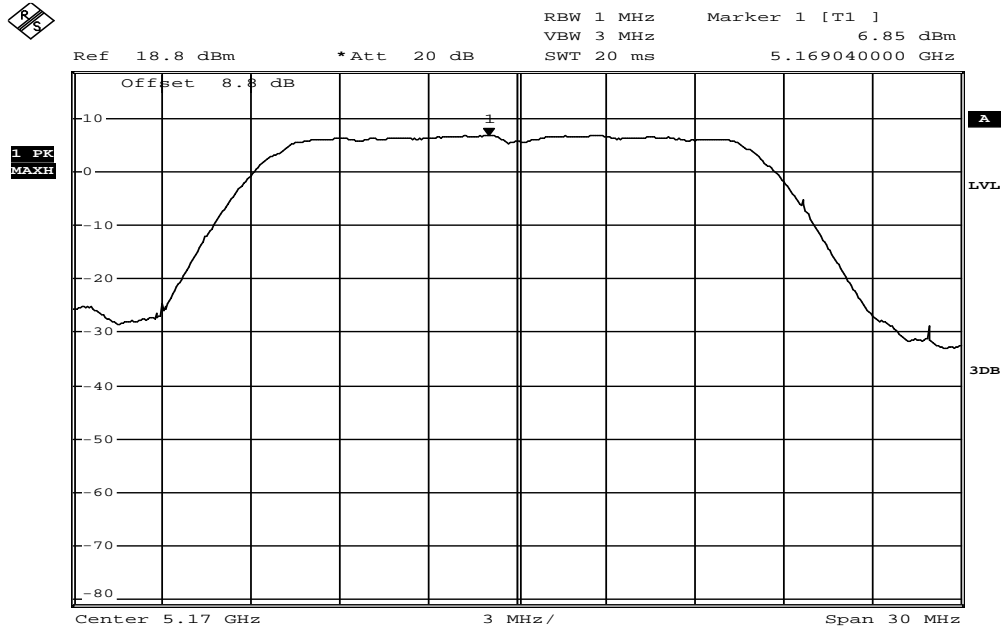

Date: 15.APR.2015 10:53:58

**Peak Power Spectral Density Data Plot (CH Mid)**

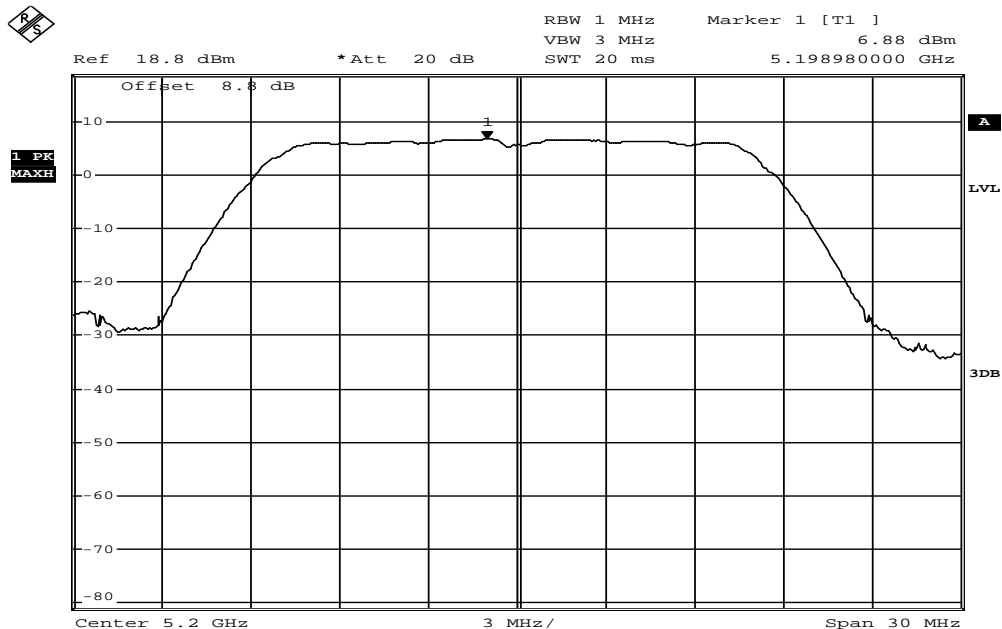

Date: 15.APR.2015 10:54:41

### Peak Power Spectral Density Data Plot (CH High)

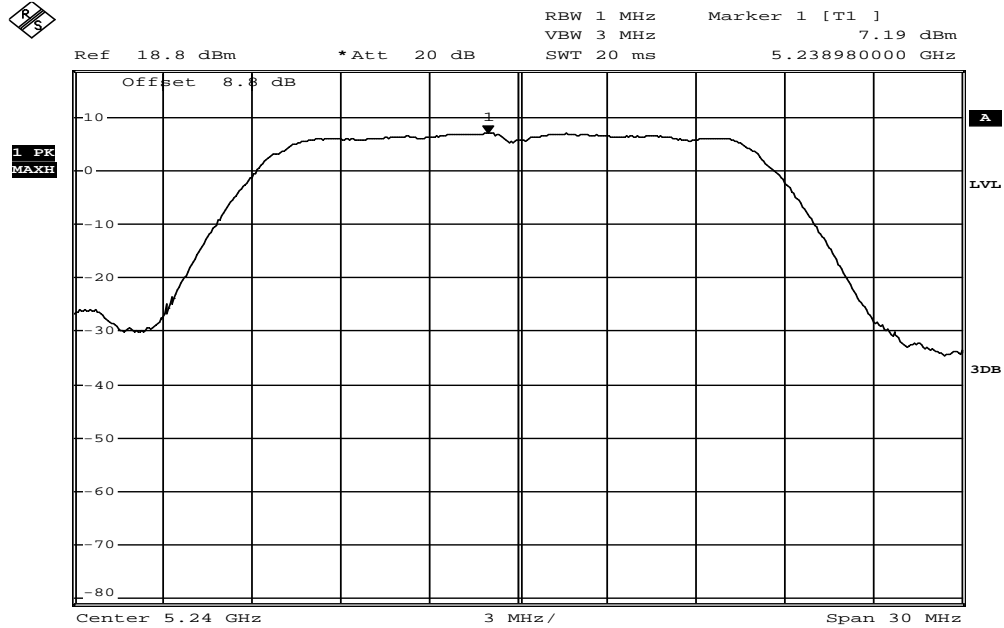

Date: 15.APR.2015 10:55:09

### 802.11n HT20 (chain a)

### Power Spectral Density Test Plot (CH-Low)

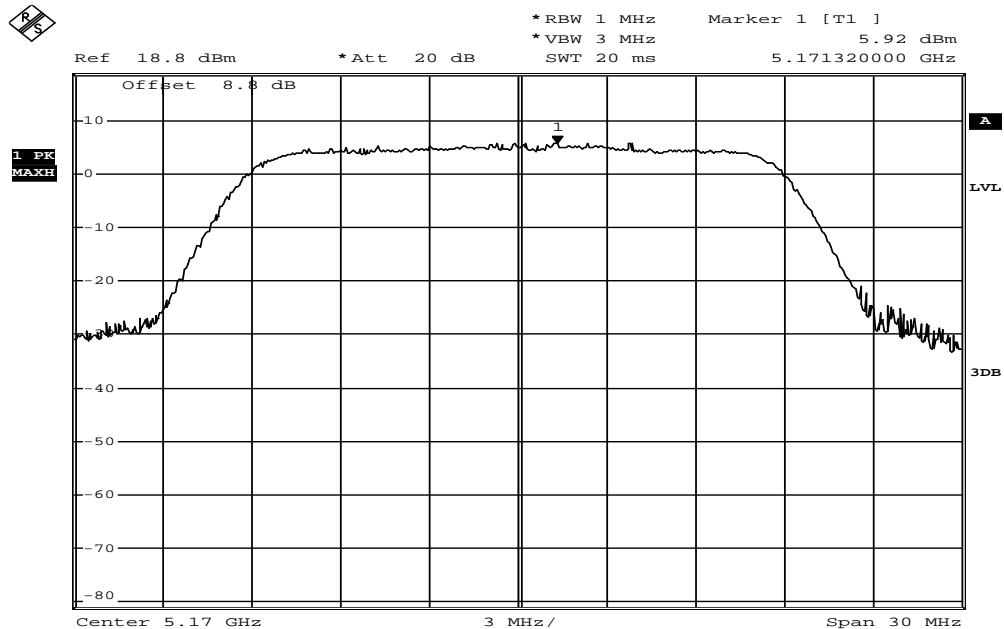

Date: 17.APR.2015 14:01:22



### 802.11n HT20 (chain b) Power Spectral Density Test Plot (CH-Low)

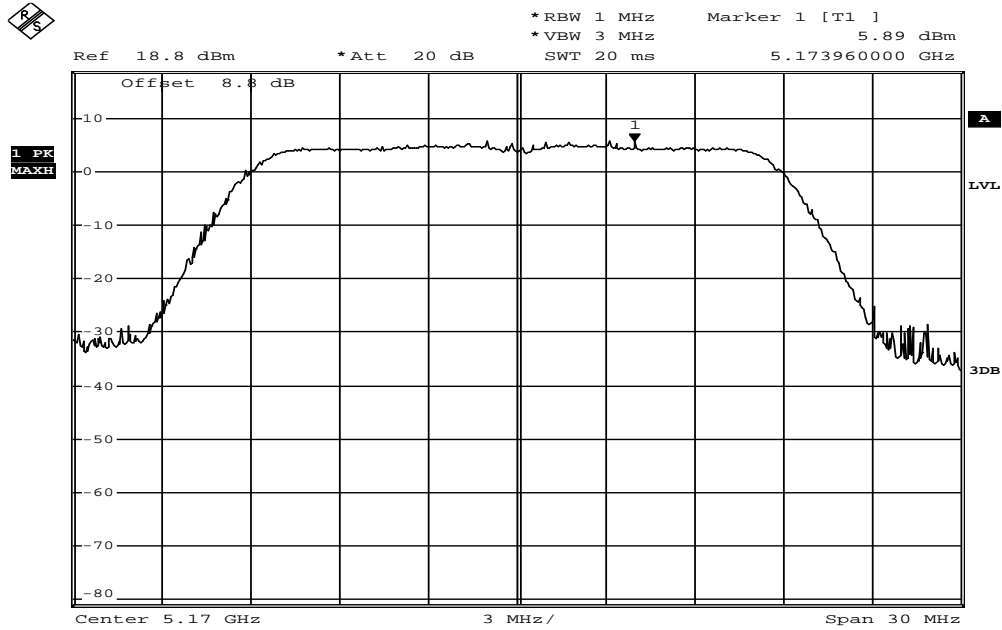

Date: 17.APR.2015 14:02:11

### Power Spectral Density Test Plot (CH-Mid)

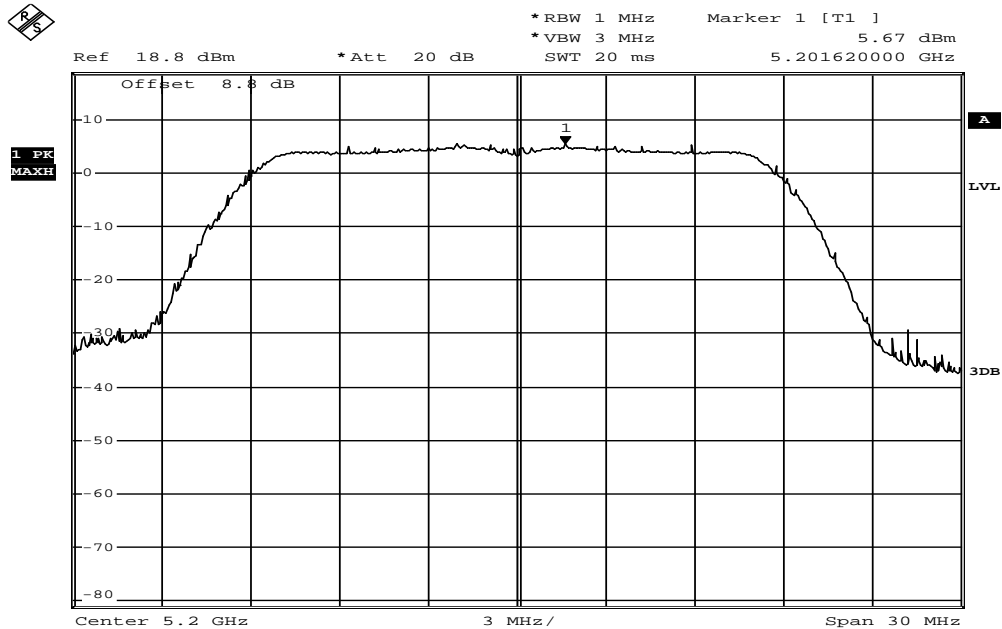

Date: 17.APR.2015 14:04:25

### Power Spectral Density Test Plot (CH-High)

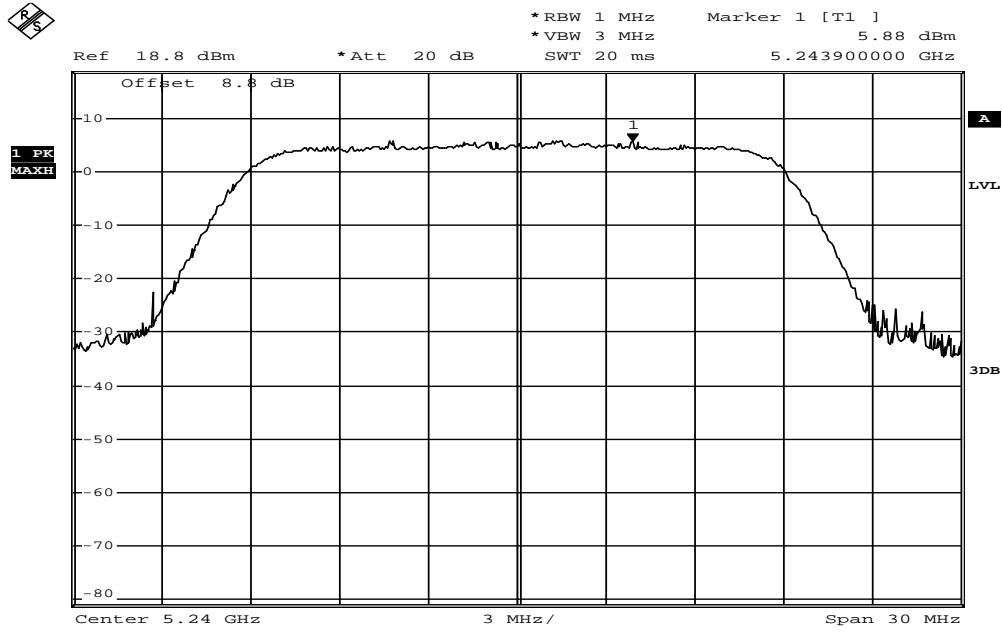

Date: 17.APR.2015 14:10:33

### 802.11n HT20 (chain c)

### Power Spectral Density Test Plot (CH-Low)

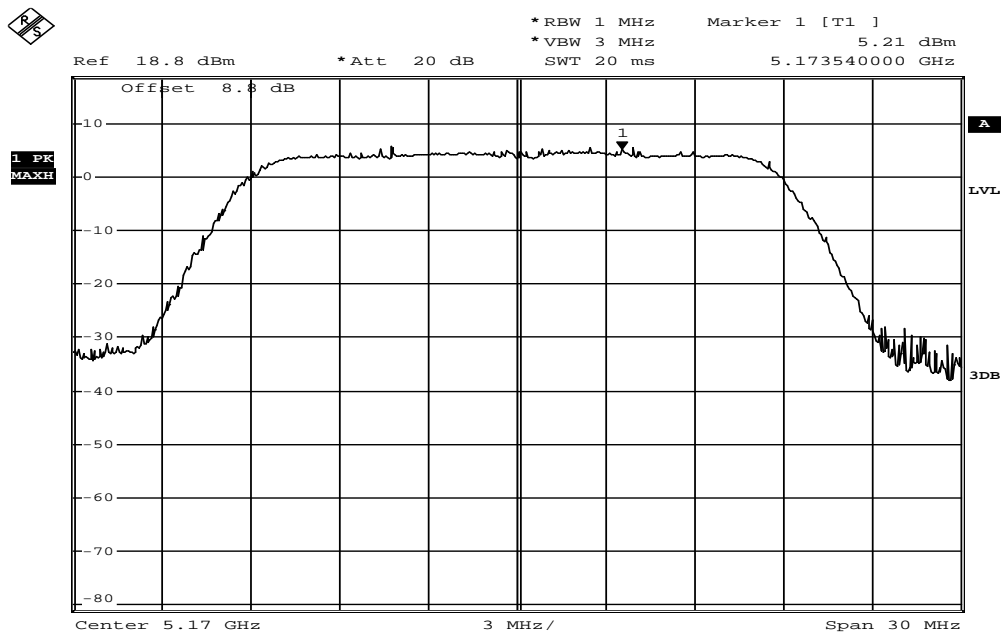

Date: 17.APR.2015 14:03:14

### Power Spectral Density Test Plot (CH-Mid)

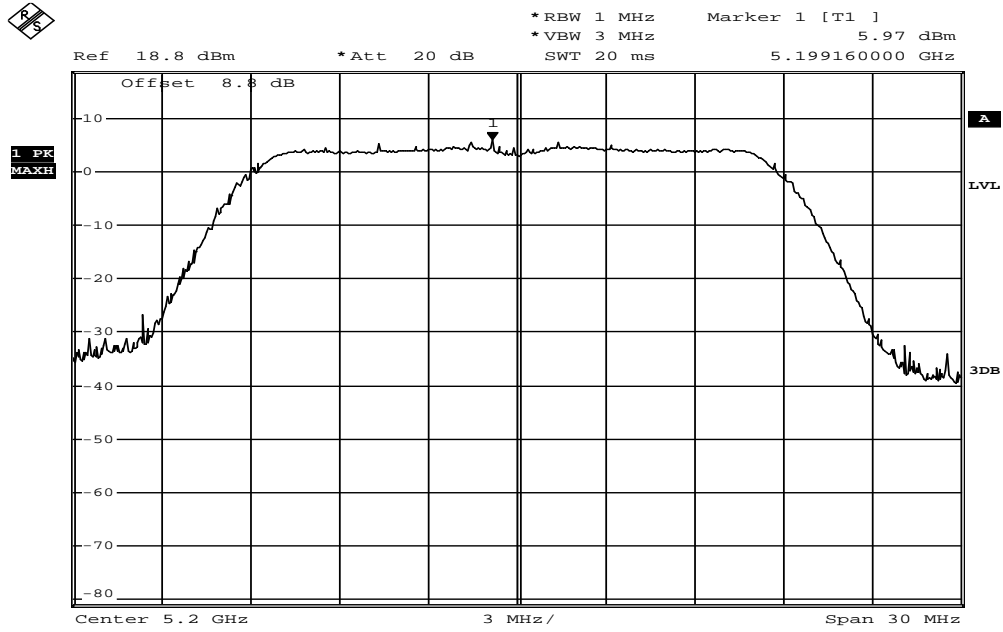

Date: 17.APR.2015 14:03:47

### Power Spectral Density Test Plot (CH-High)

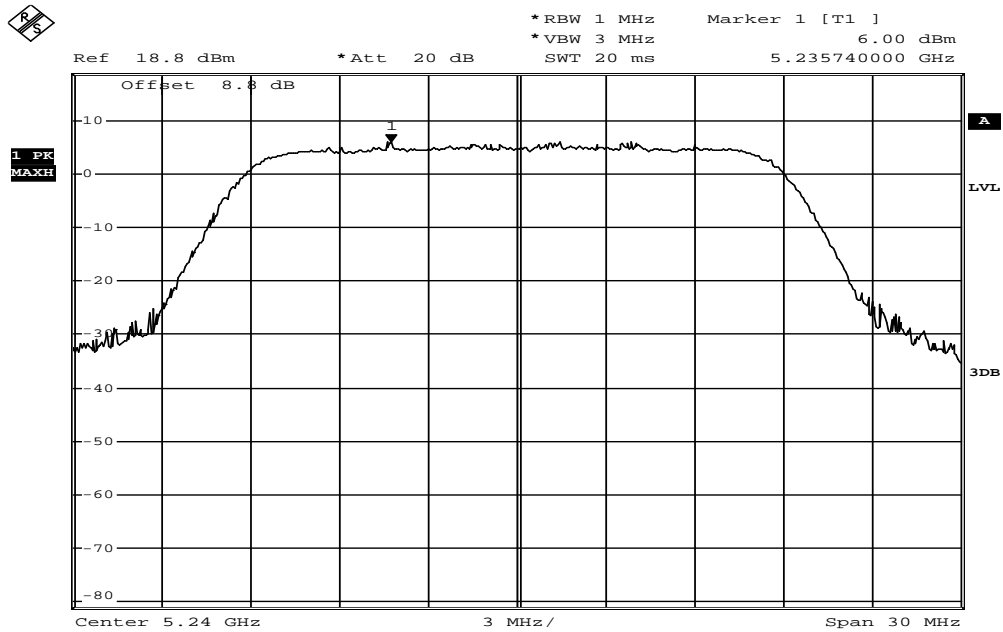

Date: 17.APR.2015 14:13:12

### 802.11n HT40 (chain a) Power Spectral Density Test Plot (CH-Low)

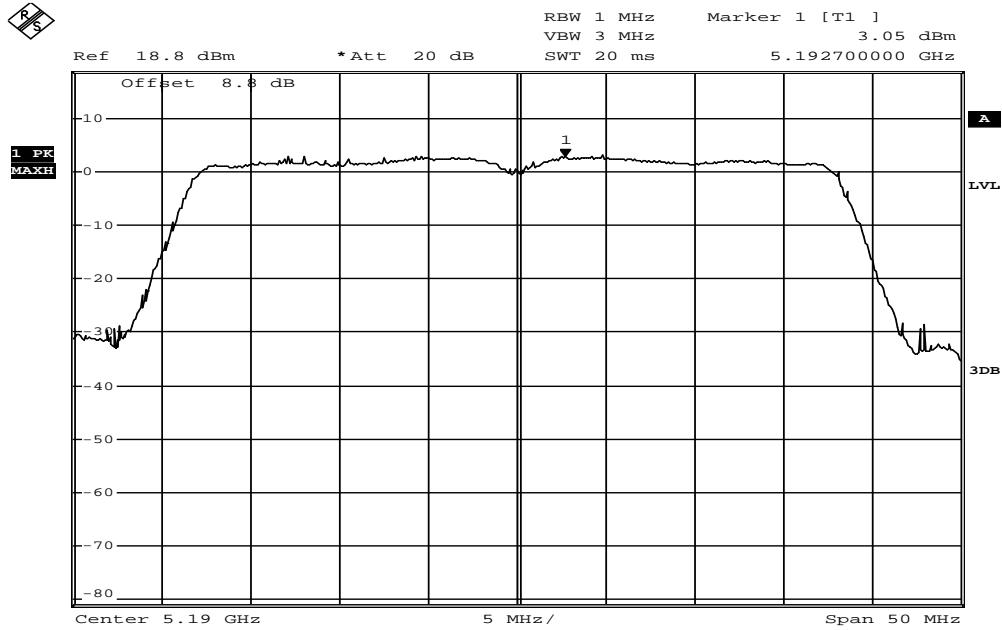

Date: 15.APR.2015 11:02:34

### Power Spectral Density Test Plot (CH-High)

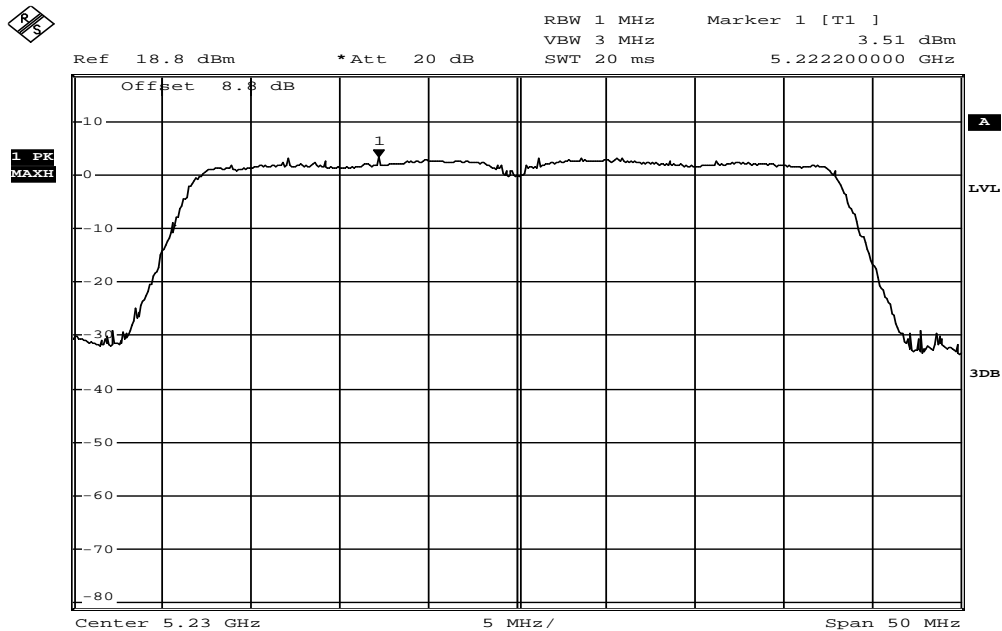

Date: 15.APR.2015 11:04:44

### 802.11n HT40 (chain b) Power Spectral Density Test Plot (CH-Low)

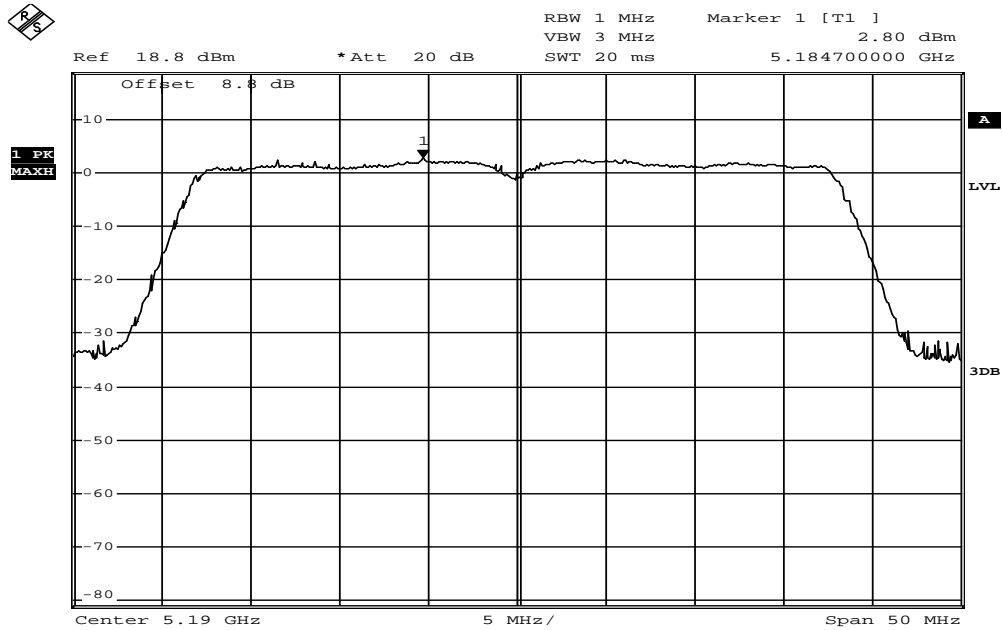

Date: 15.APR.2015 11:03:04

### Power Spectral Density Test Plot (CH-High)

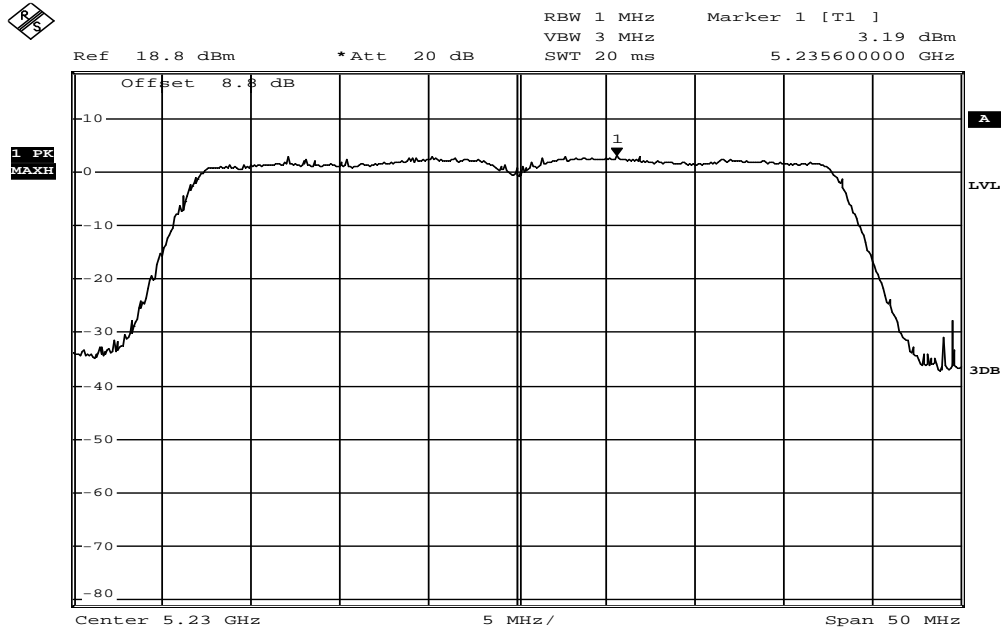

Date: 15.APR.2015 11:04:15



**802.11n HT40 (chain c)**  
**Power Spectral Density Test Plot (CH-Low)**

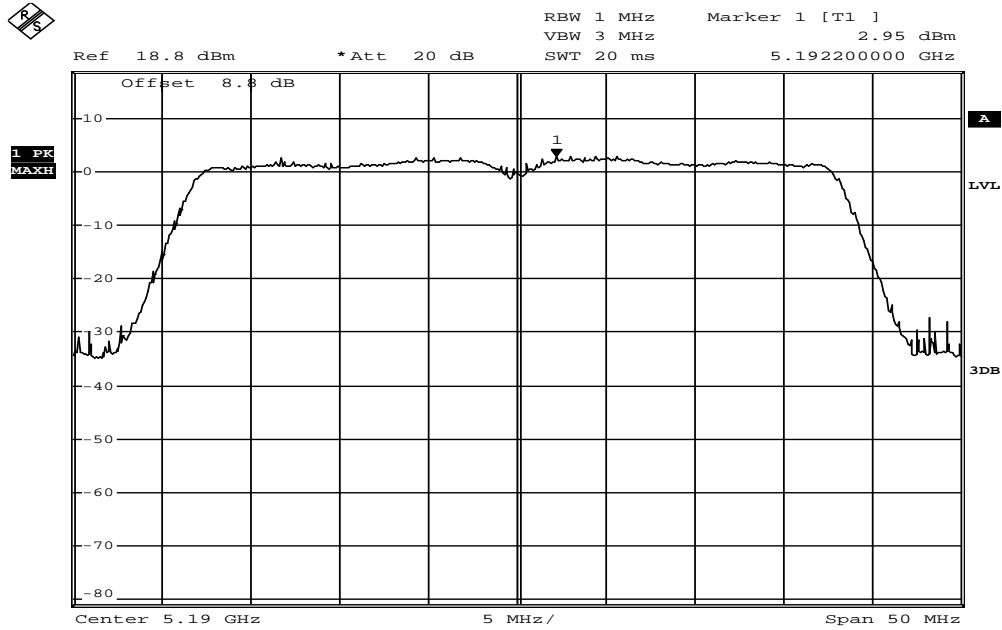

Date: 15.APR.2015 11:03:27

**Power Spectral Density Test Plot (CH-High)**

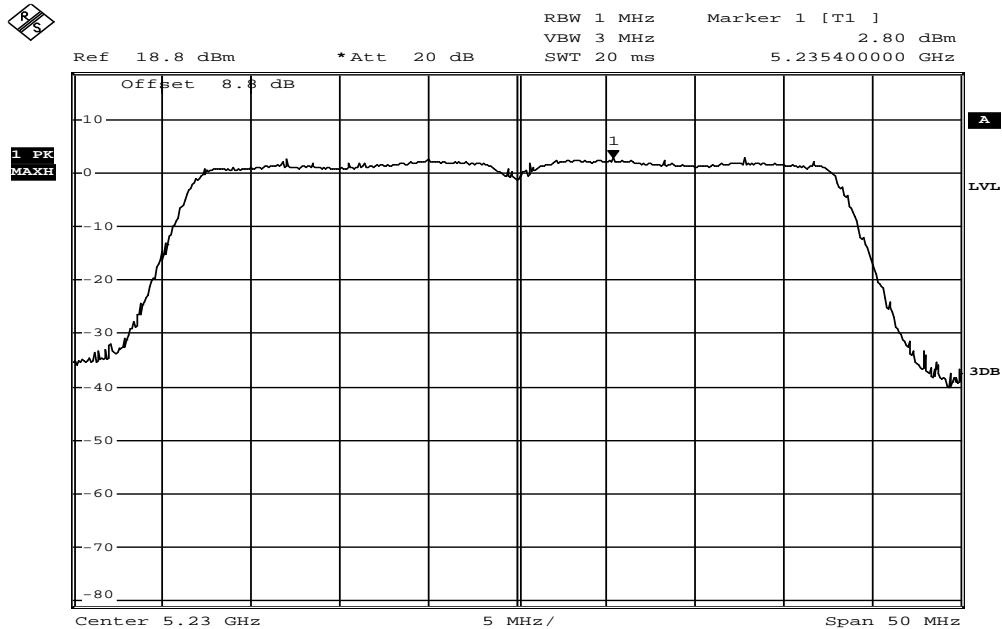

Date: 15.APR.2015 11:03:52



### 802.11AC HT80 (chain c) Power Spectral Density Test Plot (CH-Low)

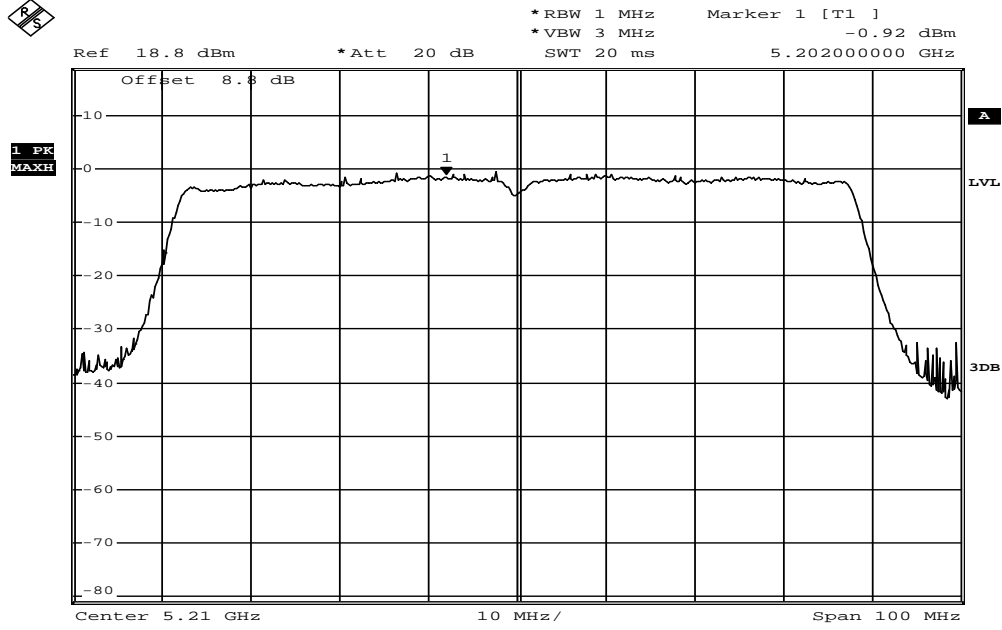

Date: 17.APR.2015 14:24:20

### 5725-5850 MHz

### 802.11a

### Peak Power Spectral Density Data Plot (CH Low)

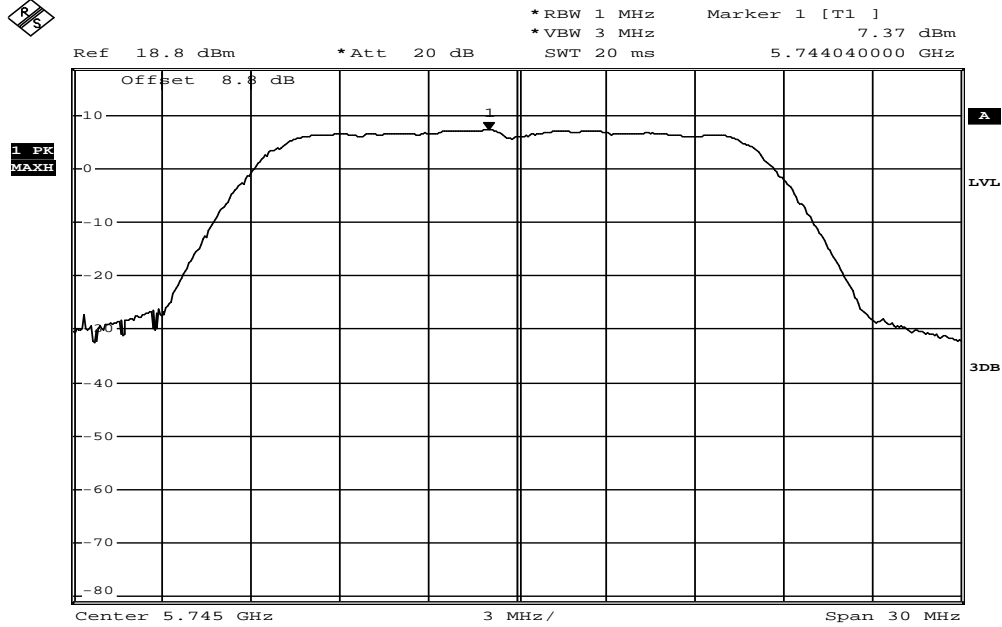

Date: 15.APR.2015 14:54:59

### Peak Power Spectral Density Data Plot (CH Mid)

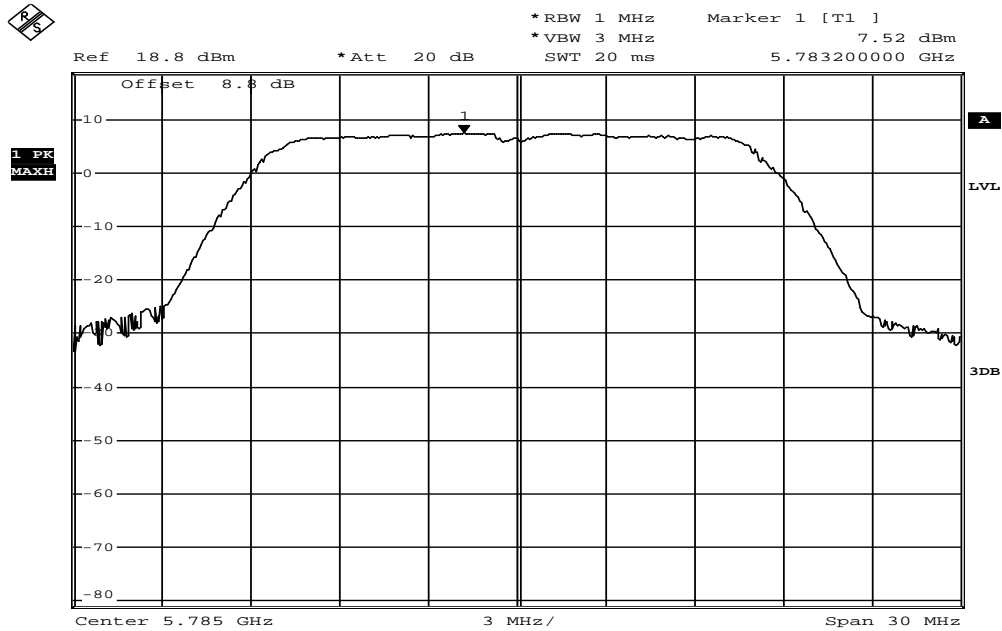

Date: 15.APR.2015 14:54:00

### Peak Power Spectral Density Data Plot (CH High)

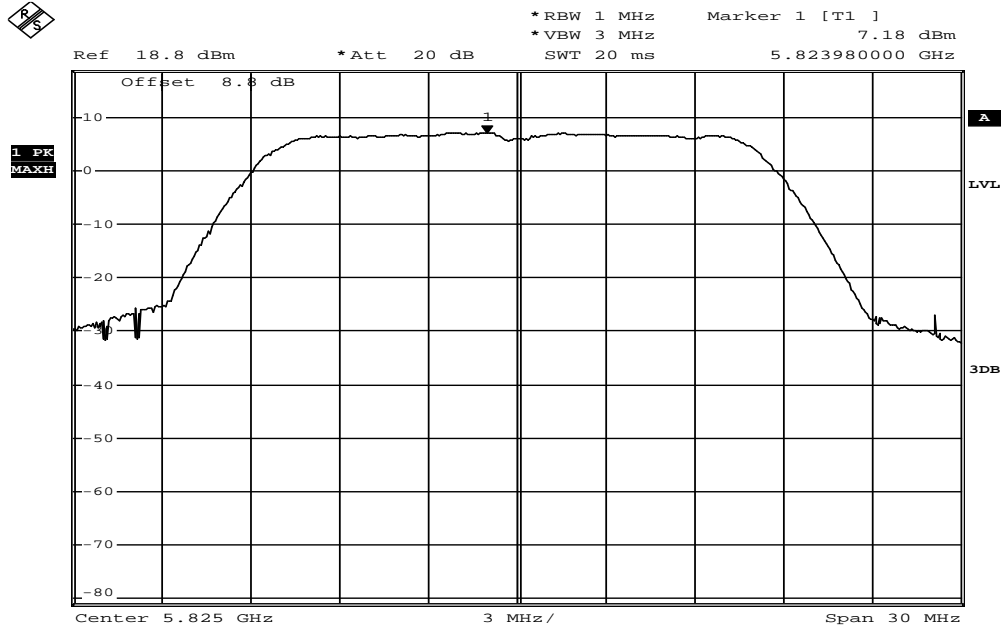

Date: 15.APR.2015 14:53:07

### 802.11n HT20 (chain a)

### Power Spectral Density Test Plot (CH-Low)

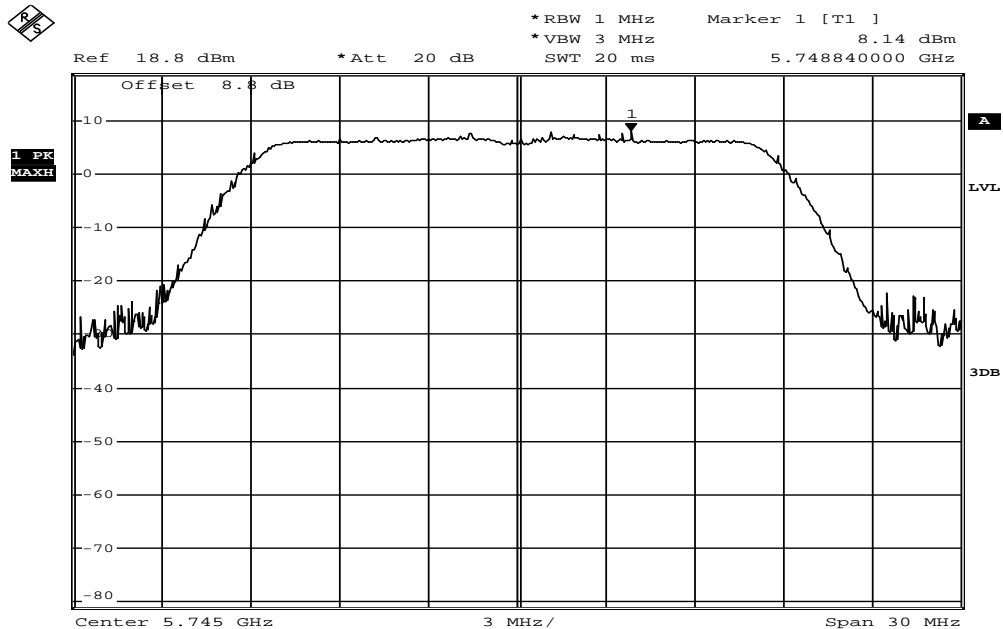

Date: 15.APR.2015 14:48:08

### Power Spectral Density Test Plot (CH-Mid)

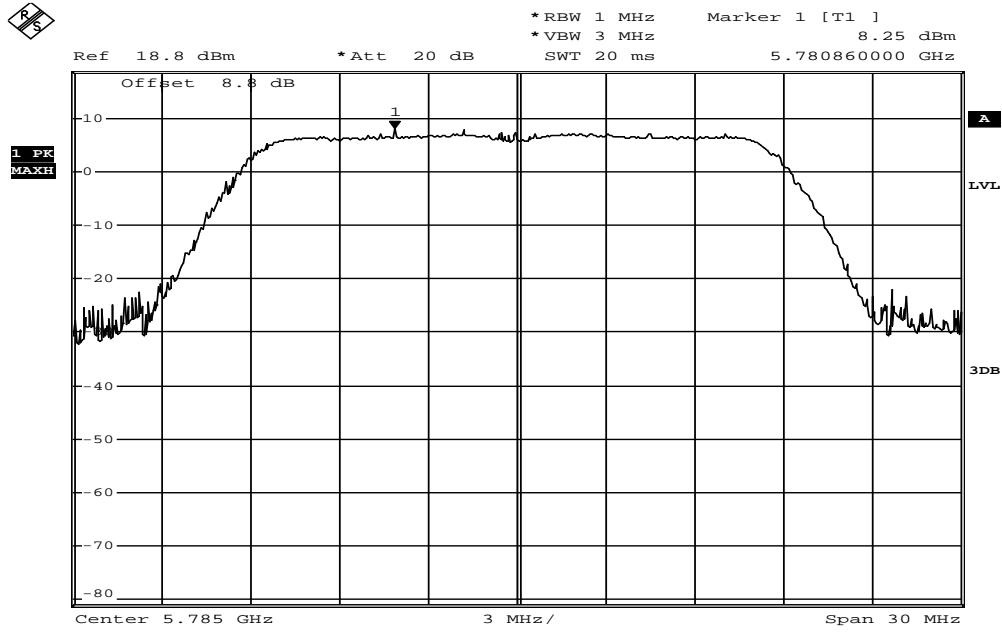

Date: 15.APR.2015 14:48:57

### Power Spectral Density Test Plot (CH-High)

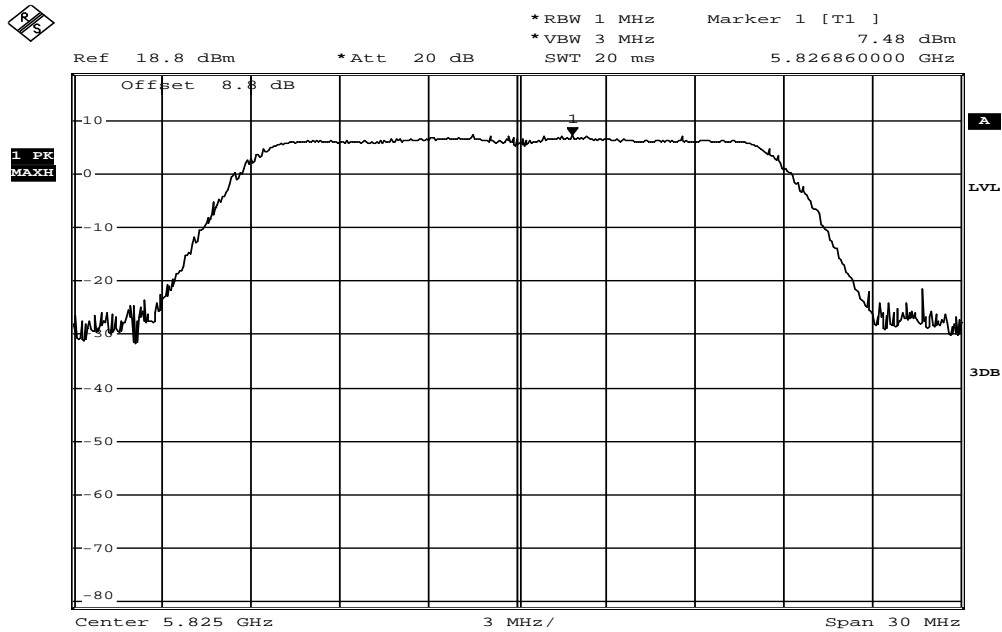

Date: 15.APR.2015 14:52:11

### 802.11n HT20 (chain b) Power Spectral Density Test Plot (CH-Low)

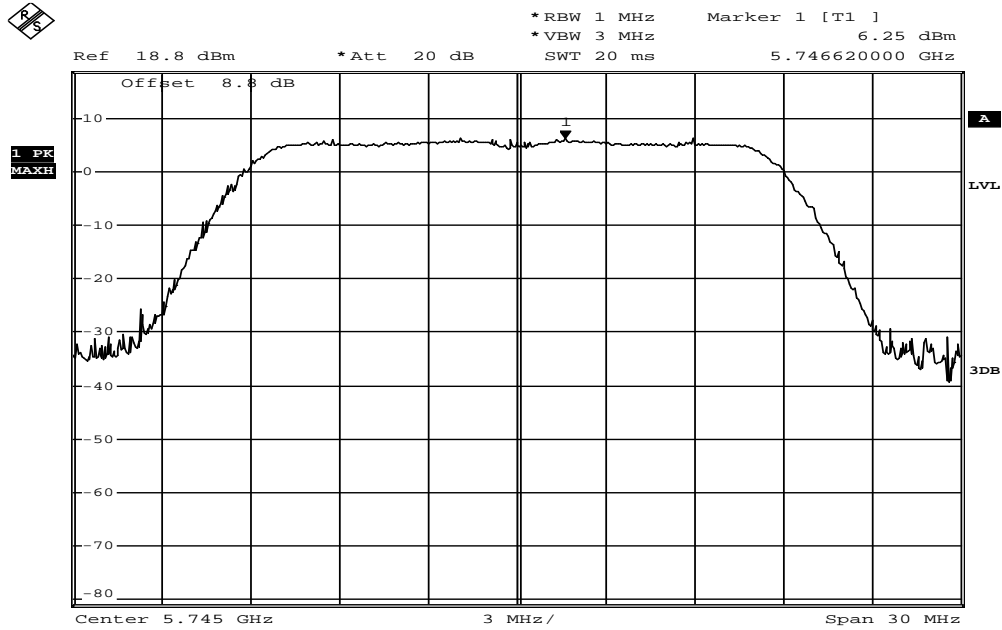

Date: 15.APR.2015 14:47:38

### Power Spectral Density Test Plot (CH-Mid)

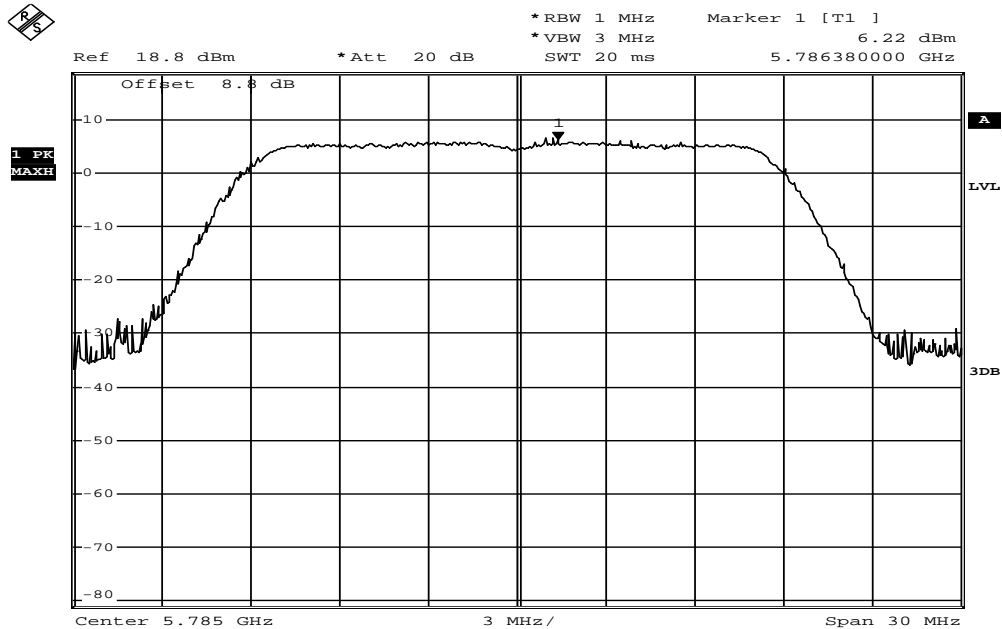

Date: 15.APR.2015 14:49:36







### 802.11n HT40 (chain a) Power Spectral Density Test Plot (CH-Low)

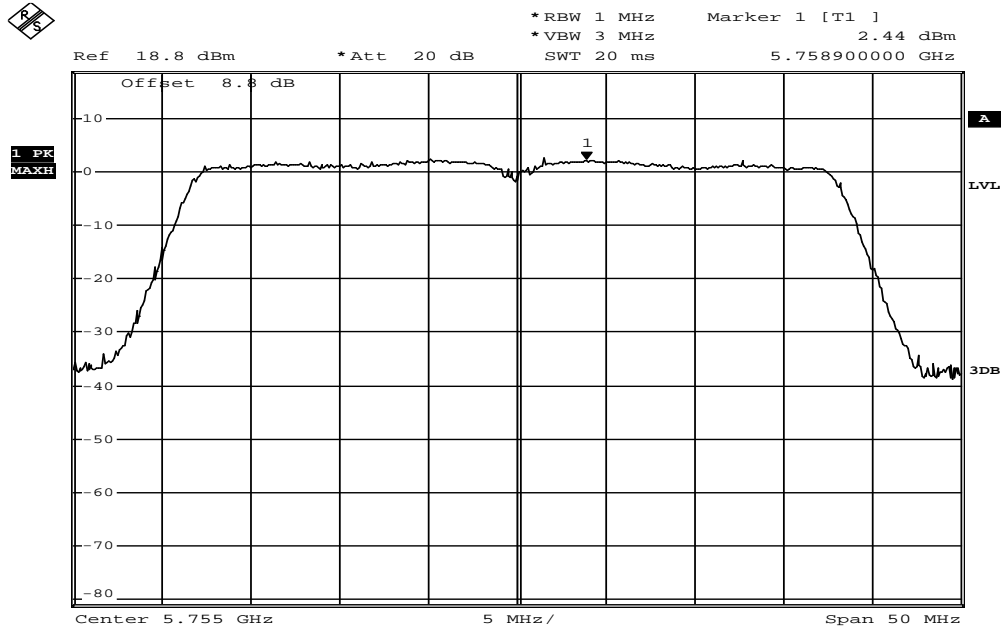

Date: 15.APR.2015 14:41:43

### Power Spectral Density Test Plot (CH-High)

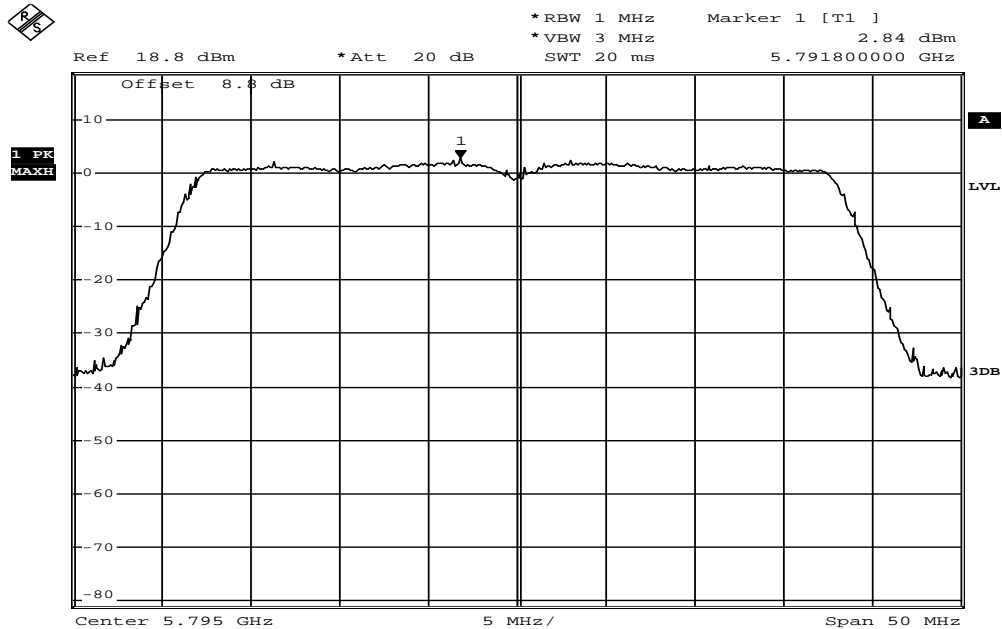

Date: 15.APR.2015 14:43:36

### 802.11n HT40 (chain b)

### Power Spectral Density Test Plot (CH-Low)

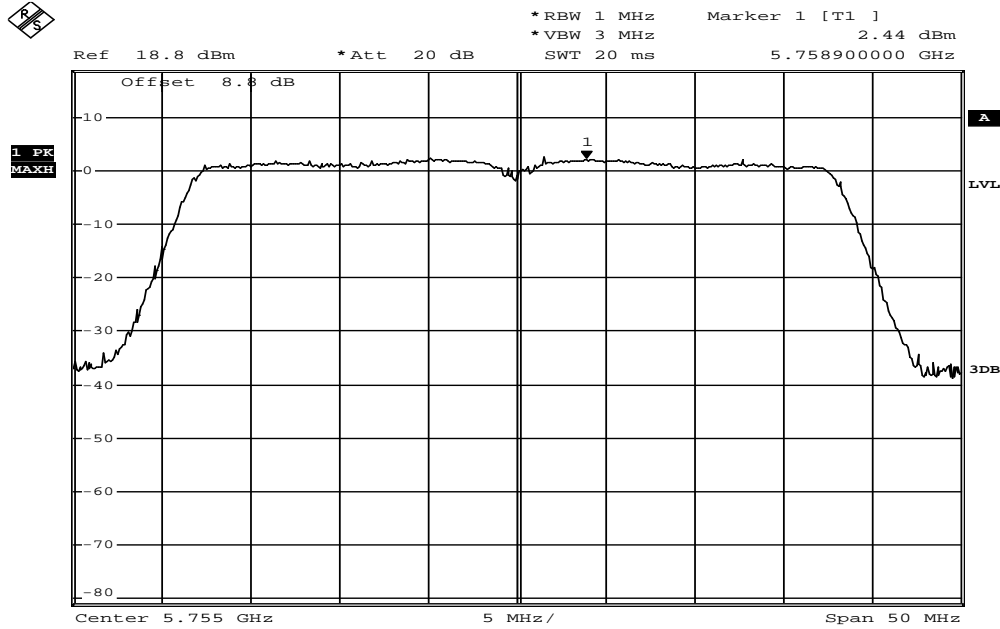

Date: 15.APR.2015 14:41:43

### Power Spectral Density Test Plot (CH-High)

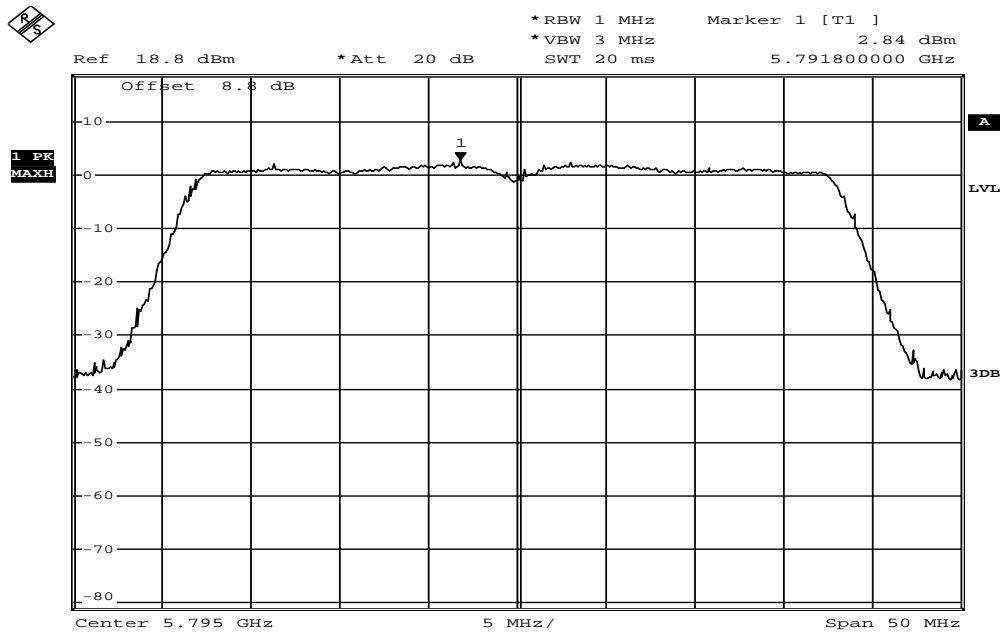

Date: 15.APR.2015 14:43:36

### 802.11n HT40 (chain c) Power Spectral Density Test Plot (CH-Low)

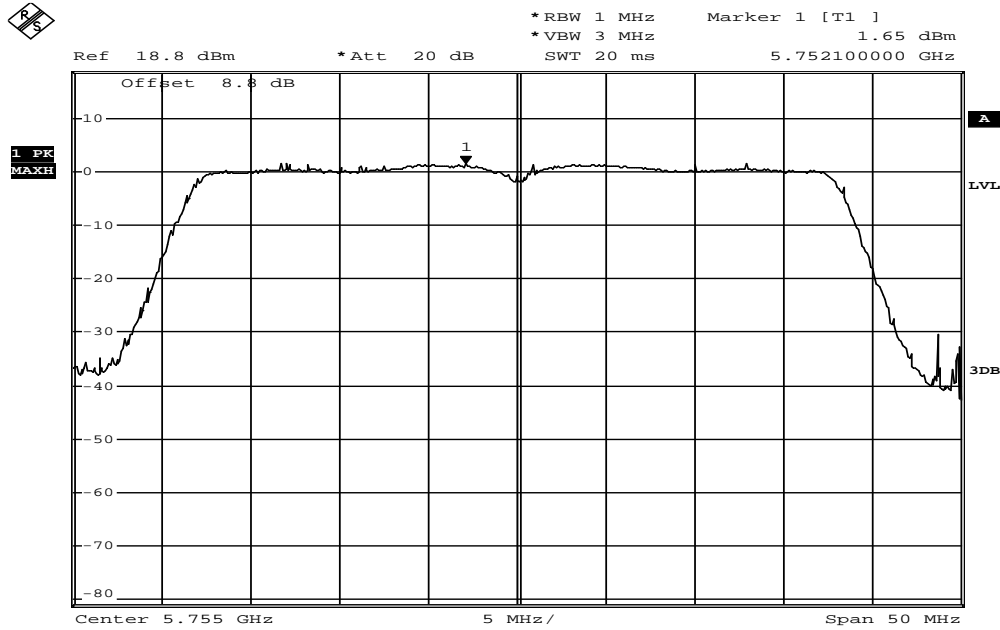

Date: 15.APR.2015 14:42:23

### Power Spectral Density Test Plot (CH-High)

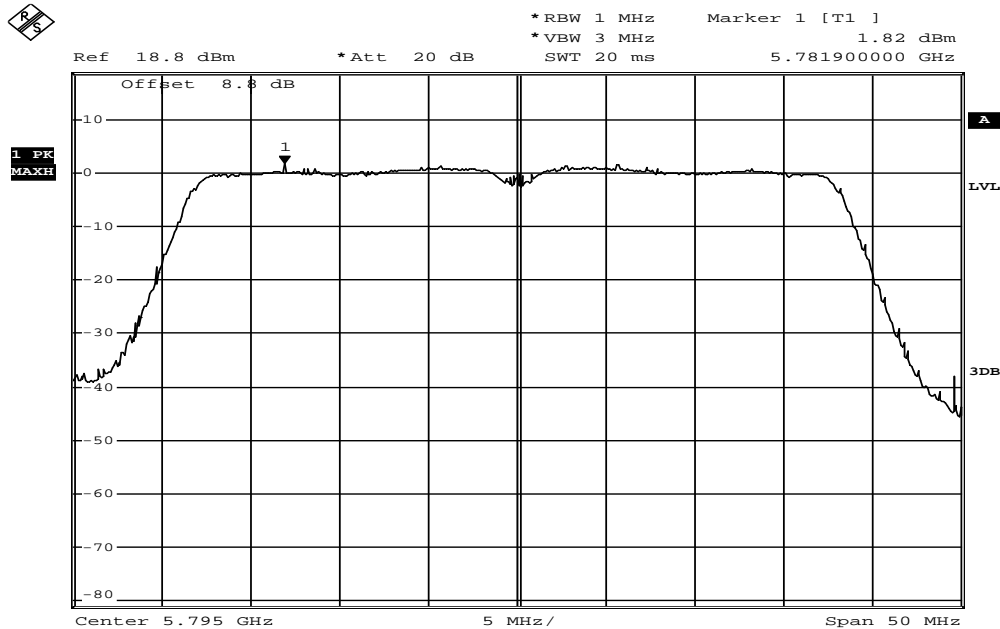

Date: 15.APR.2015 14:43:04

### 802.11AC HT80 (chain a) Power Spectral Density Test Plot (CH-Low)

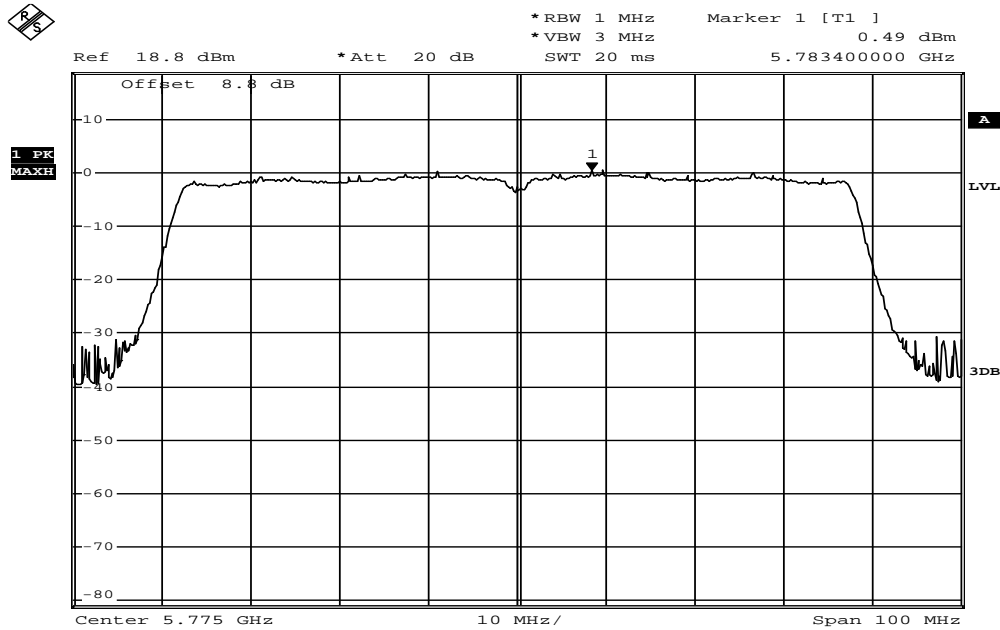

Date: 15.APR.2015 14:36:06

### 802.11AC HT80 (chain b) Power Spectral Density Test Plot (CH-Low)

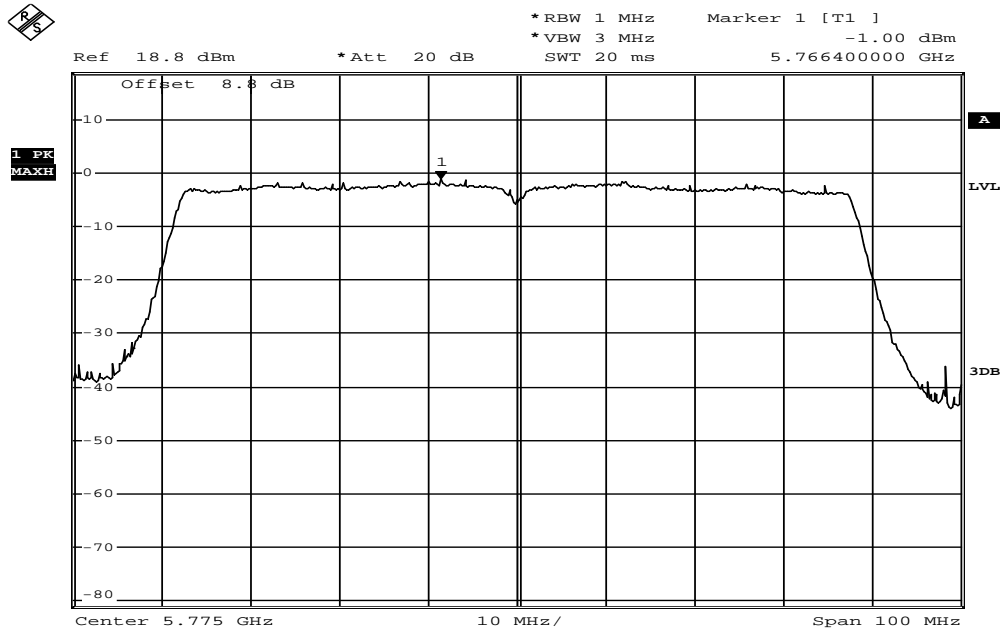

Date: 15.APR.2015 14:36:49



## **7. 26dB /99% EMISSION BANDWIDTH MEASUREMENT**

### **7.1 Standard Applicable**

According to §15.407(a). No Limit required.

### **7.2 Measurement Procedure**

1. Place the EUT on the table and set it in transmitting mode.
2. Remove the antenna from the EUT and then connect a low loss RF cable from the antenna port to the spectrum analyzer.
3. Set the spectrum analyzer as RBW=300KHz/1MHz, VBW =1MHz/3MHz, Span=30/50/90MHz,, Sweep=auto
4. Mark the peak frequency and -26dB (upper and lower) frequency.
5. Repeat above procedures until all frequency measured were complete.

**Refer to section D of KDB Document: KDB 789033 D02 General UNII Test Procedures New Rules v01**

### **7.3 Measurement Equipment Used:**

Refer to section 6.3 for details.

### **7.4 Test Set-up:**

Refer to section 6.4 for details.

## 7.5 Measurement Result

### 5150-5250 MHz

#### 802.11a Mode

Frequency (MHz)	26dB Bandwidth (MHz)	99% Bandwidth (MHz)
5170	20.580	17.040
5200	20.580	16.980
5240	20.640	17.040

#### 802.11n HT20 Mode

Frequency (MHz)	26dB Bandwidth (MHz)	99% Bandwidth (MHz)
5170	21.060	18.060
5200	21.060	18.060
5240	20.940	18.060

#### 802.11n HT40 Mode

Frequency (MHz)	26dB Bandwidth (MHz)	99% Bandwidth (MHz)
5190	41.600	36.900
5230	41.800	36.900

#### 802.11a HT80 Mode

Frequency (MHz)	26dB Bandwidth (MHz)	99% Bandwidth (MHz)
5210	82.980	75.960



**5150-5250MHz**

**802.11a**

**26dB & 99% Band Width Test Data CH-Low**

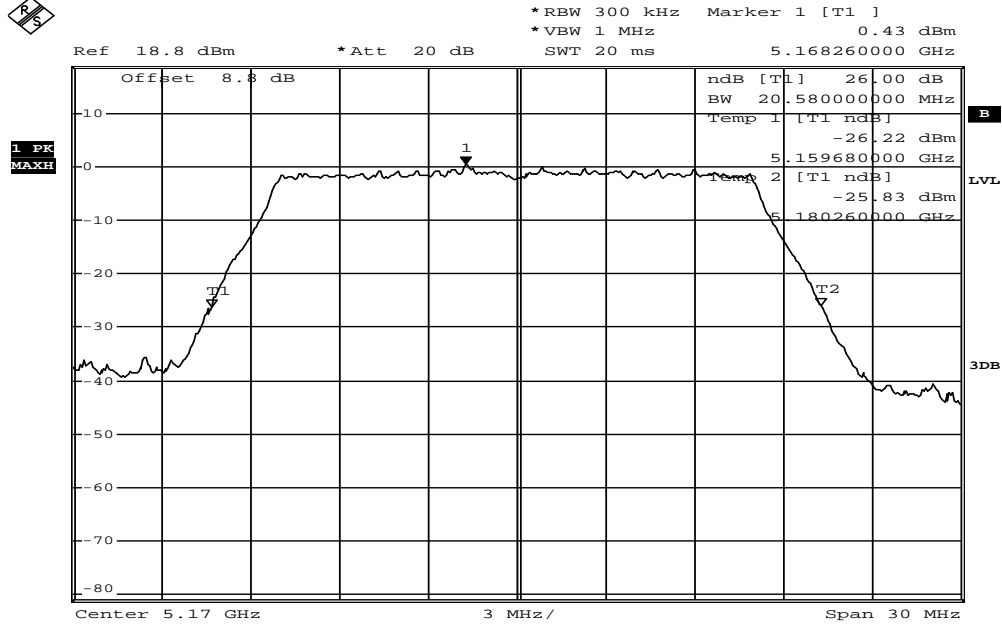

Date: 13.APR.2015 16:45:45

**26dB & 99% Band Width Test Data CH-Mid**

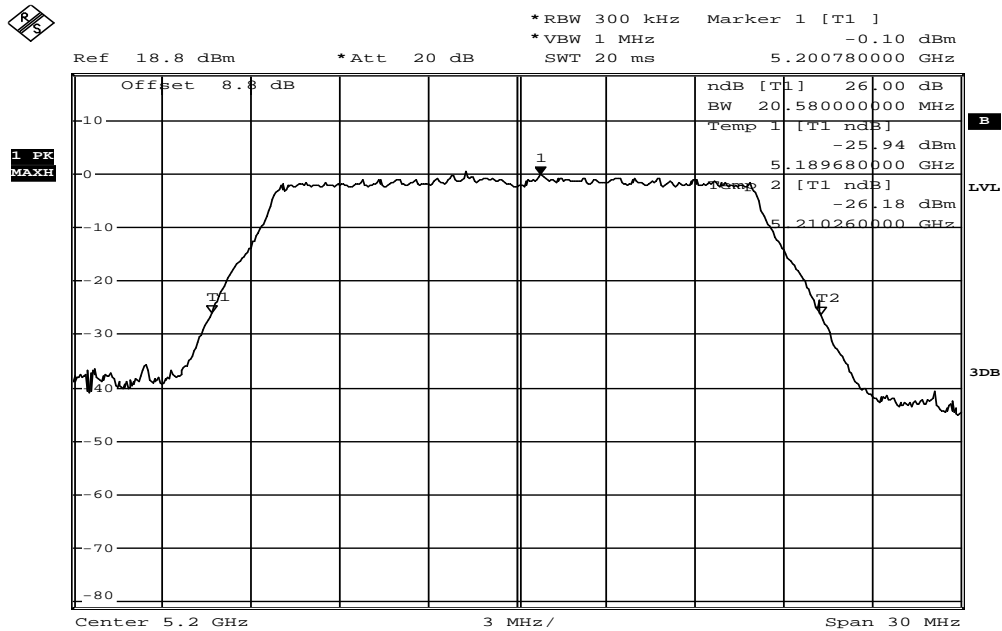

Date: 13.APR.2015 16:46:16

### 26dB & 99% Band Width Test Data CH-High

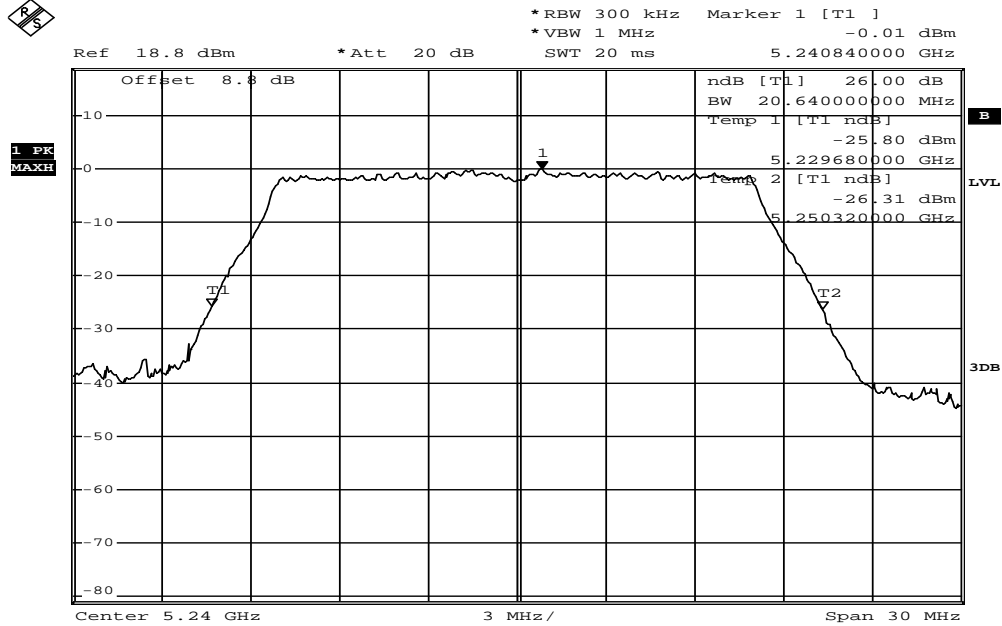

Date: 13.APR.2015 16:47:35

### 802.11n HT20

### 26dB & 99% Band Width Test Data CH-Low

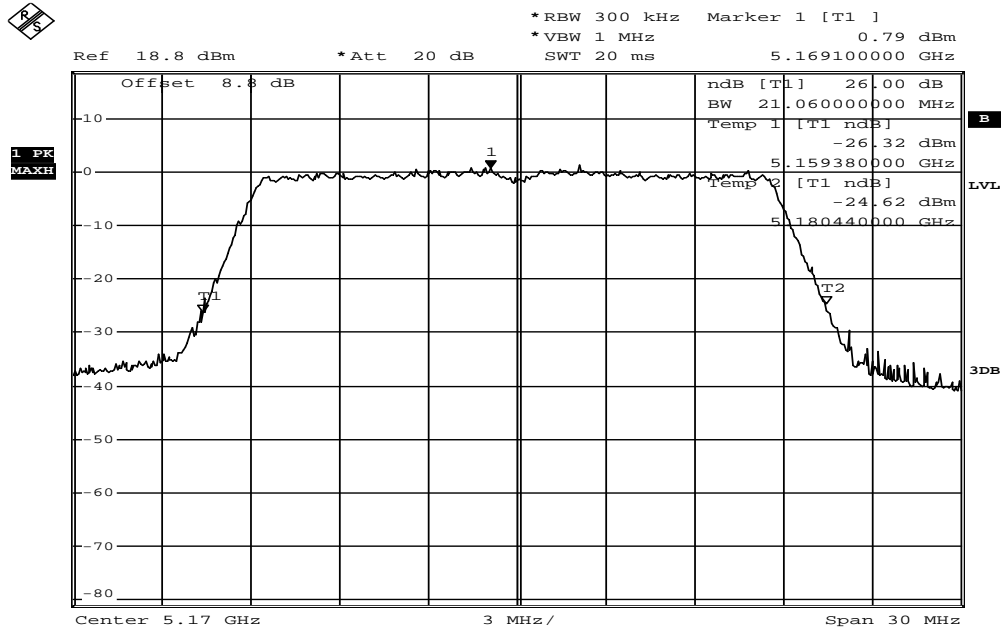

Date: 13.APR.2015 16:52:29

### 26dB &99% Band Width Test Data CH-Mid

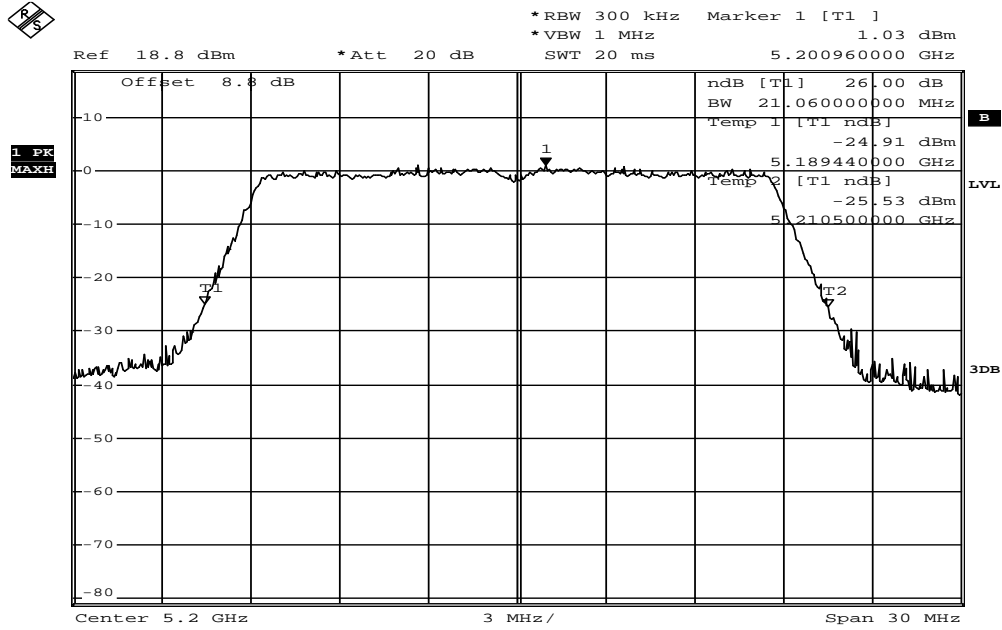

Date: 13.APR.2015 16:53:52

### 26dB &99% Band Width Test Data CH-High

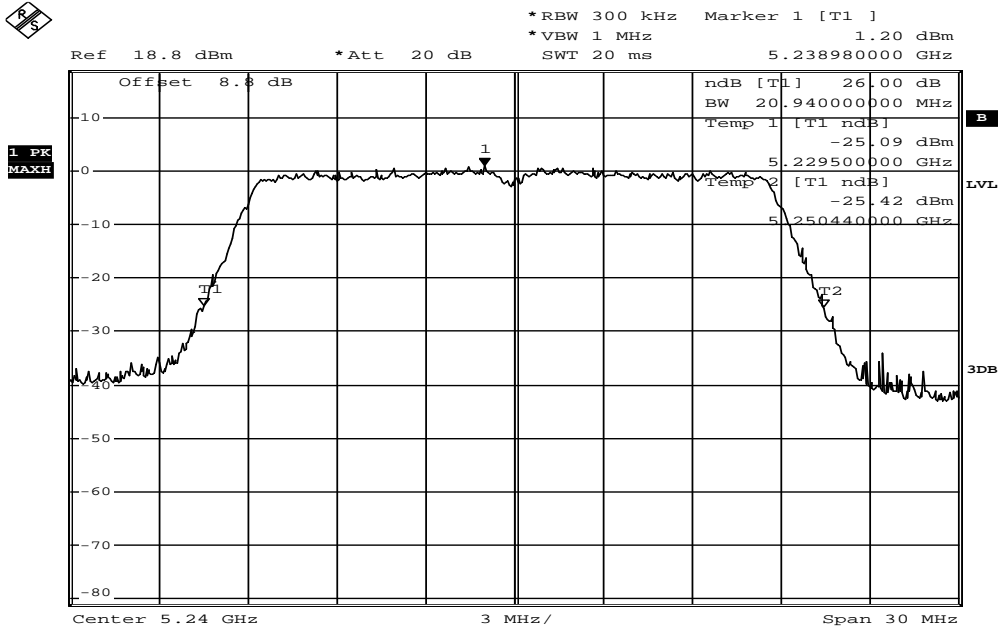

Date: 13.APR.2015 16:54:22

### 802.11n HT40 26dB &99% Band Width Test Data CH-Low

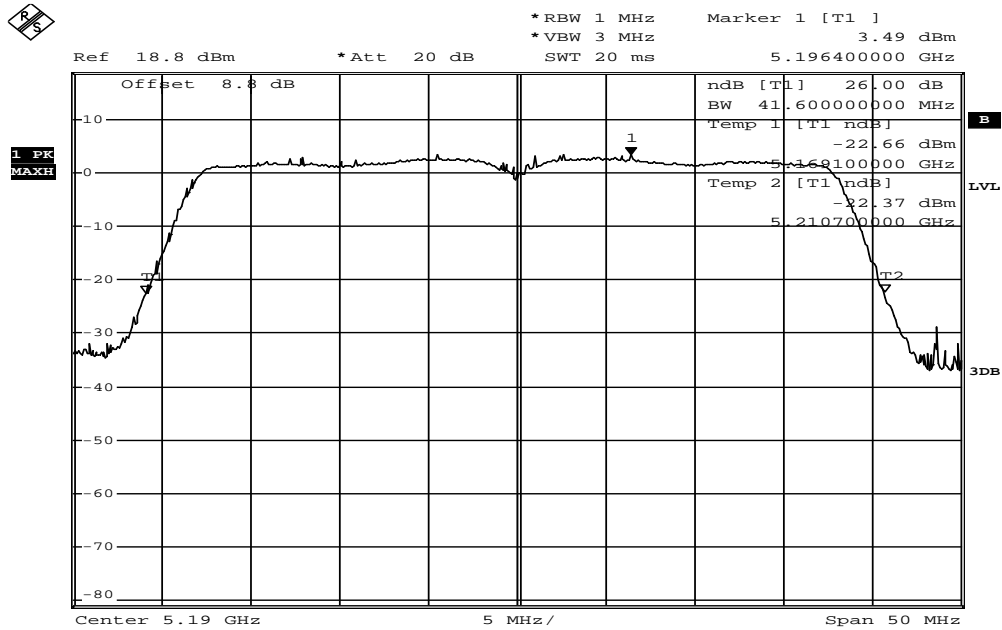

Date: 13.APR.2015 17:02:54

### 26dB &99%Band Width Test Data CH-High

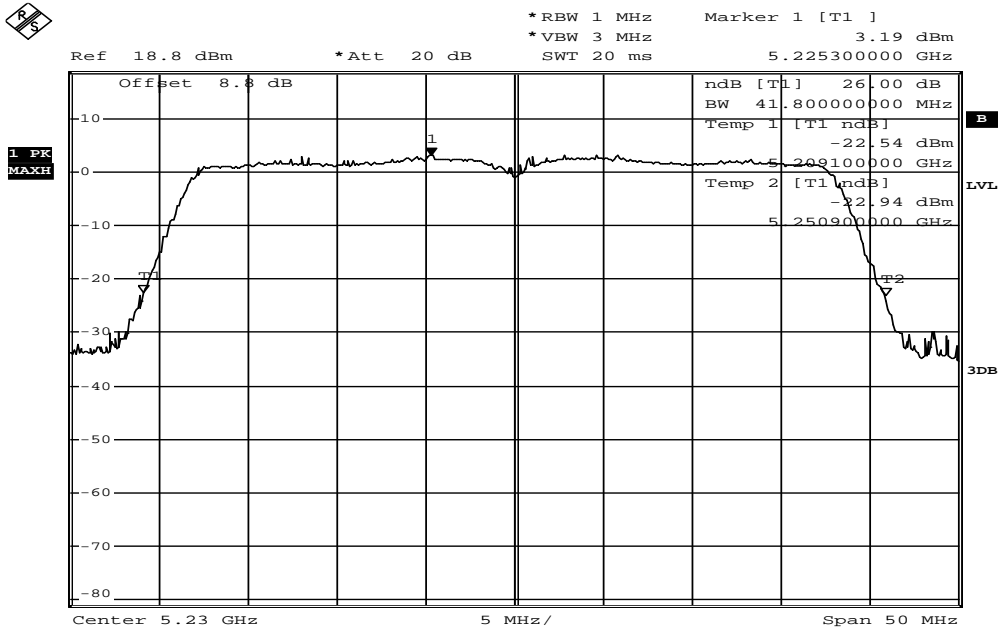

Date: 13.APR.2015 17:04:24

## 802.11AC HT80 26dB & 99% Band Width Test Data

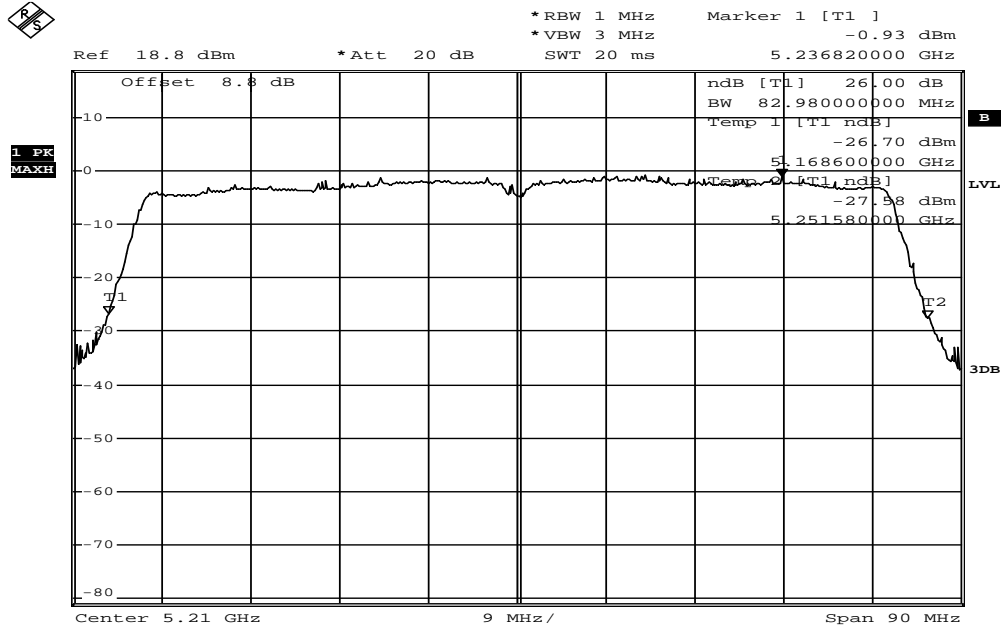

Date: 13.APR.2015 17:01:48

**5725-5850 MHz**  
**802.11a**  
**99% Band Width Test Data CH-Low**

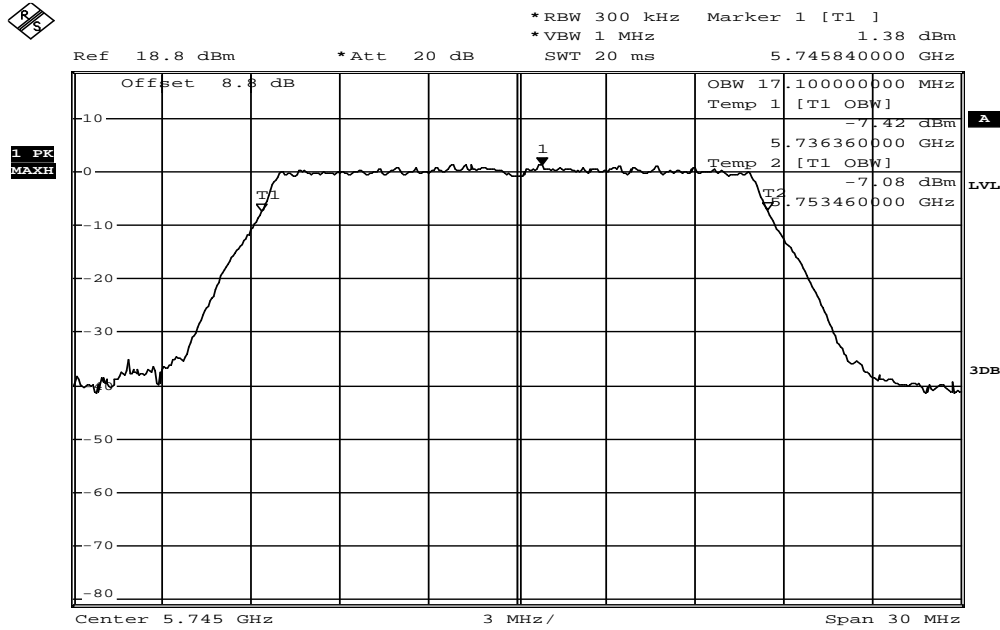

Date: 15.APR.2015 14:20:57

**99% Band Width Test Data CH-Mid**

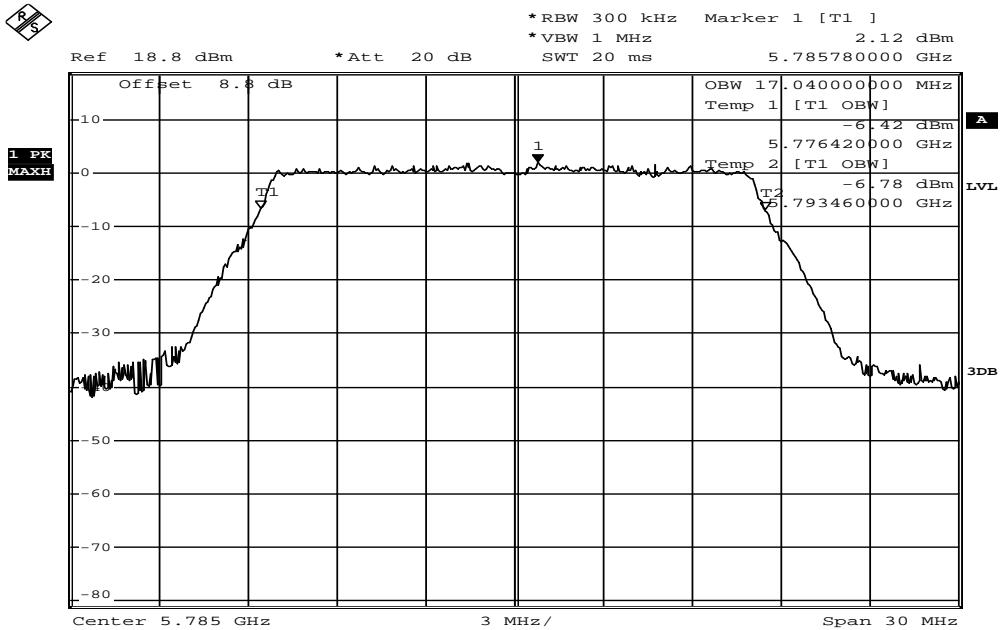

Date: 15.APR.2015 14:18:26

### 99% Band Width Test Data CH-High

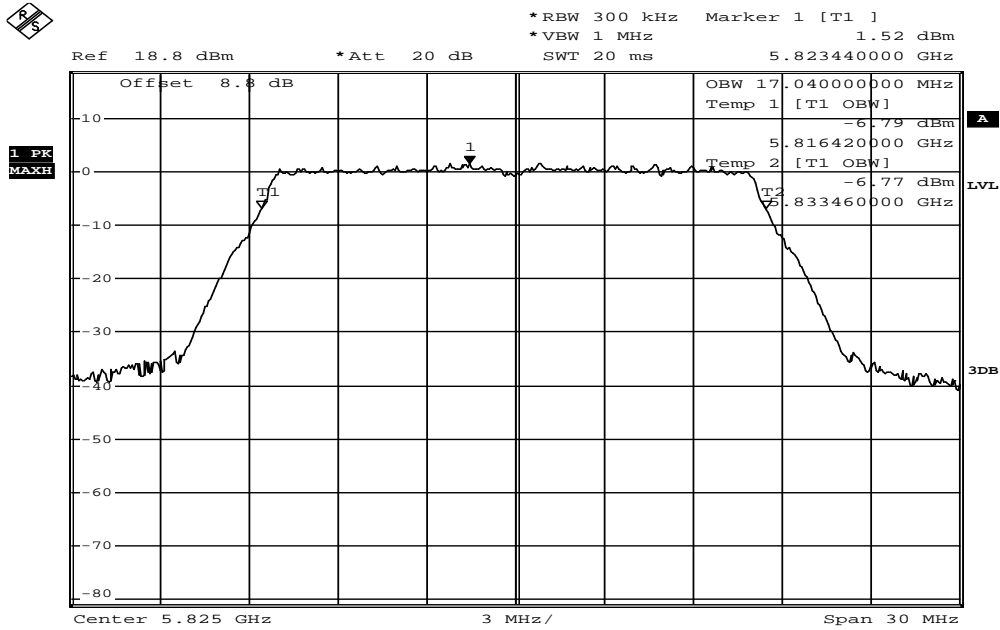

Date: 15.APR.2015 14:17:54

### 802.11n HT20

### 99% Band Width Test Data CH-Low

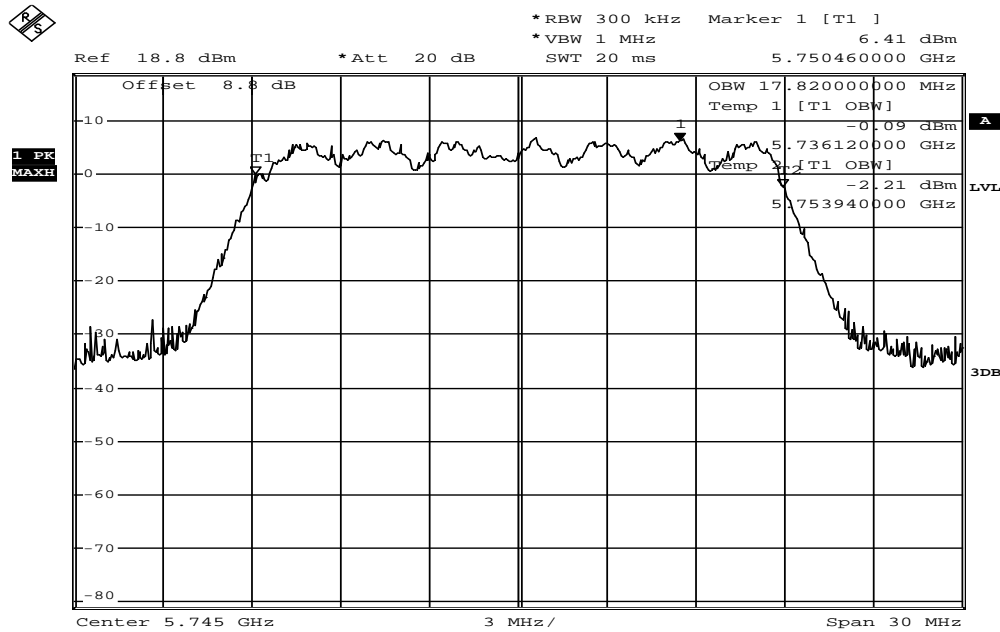

Date: 15.APR.2015 14:22:06

### 99% Band Width Test Data CH-Mid

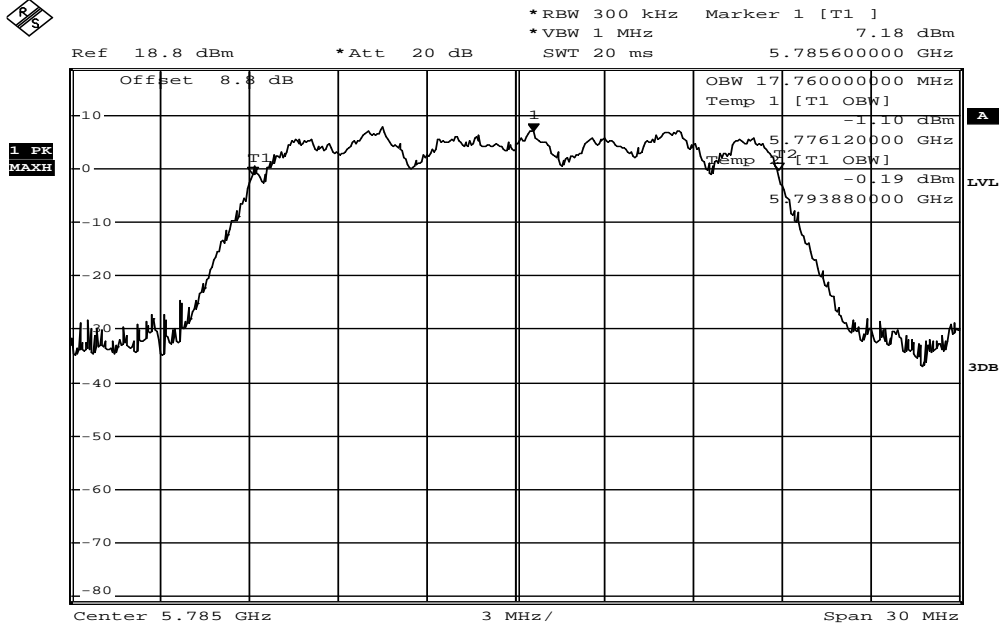

Date: 15.APR.2015 14:25:28

### 99% Band Width Test Data CH-High

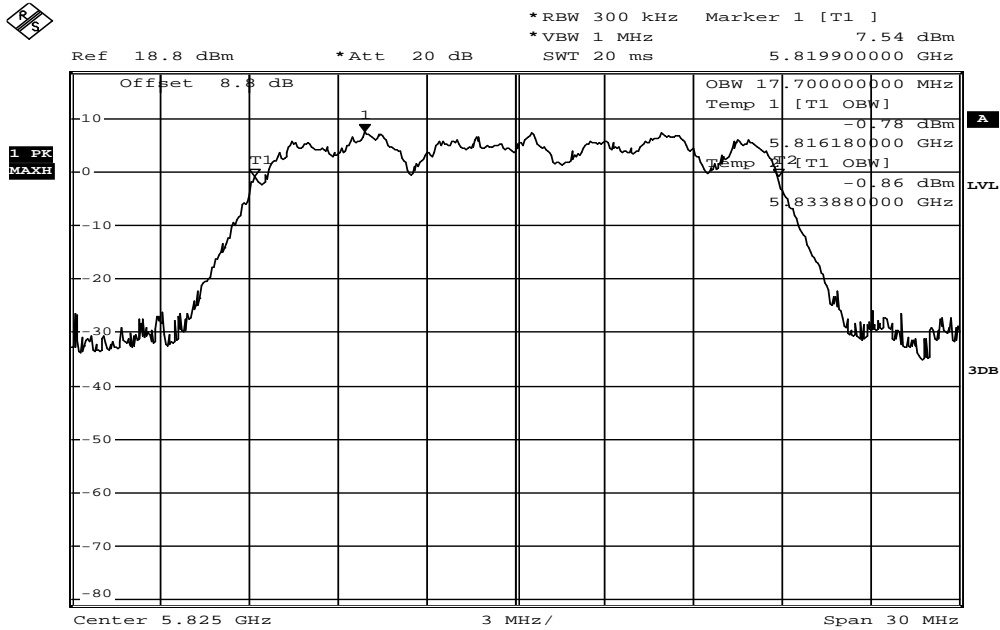

Date: 15.APR.2015 14:26:02



**802.11n HT40**  
**99% Band Width Test Data CH-Low**

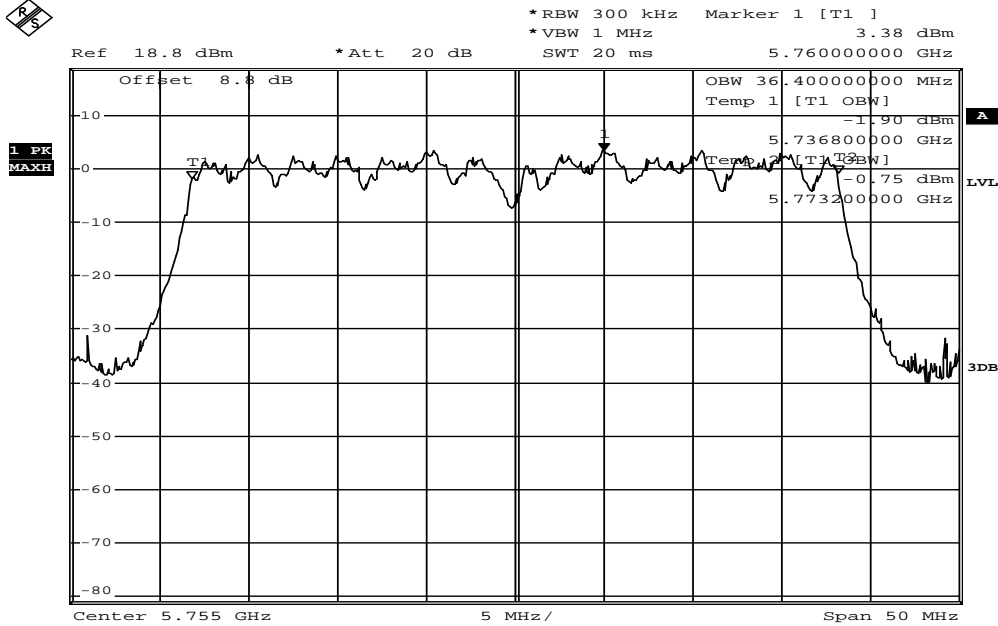

Date: 15.APR.2015 14:26:42

**99% Band Width Test Data CH-High**

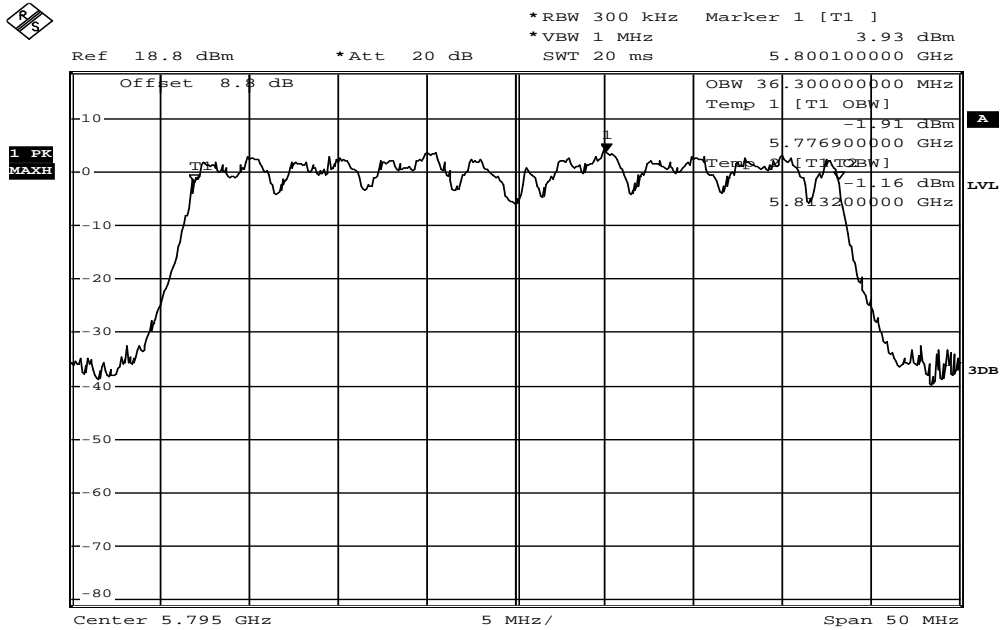

Date: 15.APR.2015 14:27:09

**802.11AC HT80**  
**99% Band Width Test Data CH-Low**

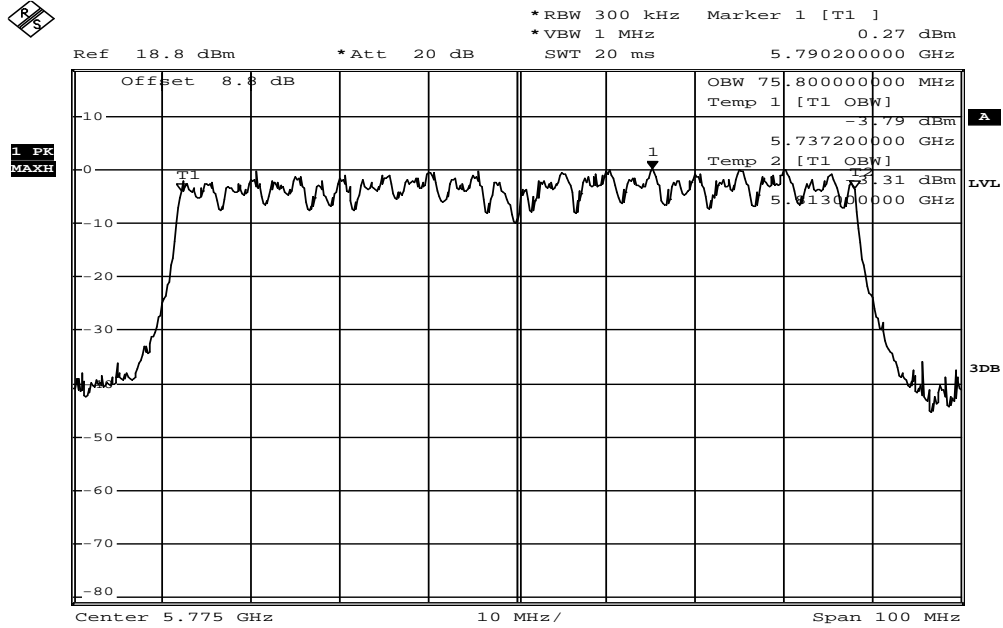

Date: 15.APR.2015 14:30:53

## **8. 6dB EMISSION BANDWIDTH MEASUREMENT**

### **8.1 Standard Applicable**

According to §15.407 (e) Within the 5.725-5.85 GHz band, the minimum 6 dB bandwidth of U-NII devices shall be at least 500 kHz.

### **8.2 Measurement Procedure**

1. Place the EUT on the table and set it in transmitting mode.
2. Remove the antenna from the EUT and then connect a low loss RF cable from the antenna port to the spectrum analyzer.
3. Set the spectrum analyzer as RBW=100KHz, VBW =300MHz, Span= 30/50/100MHz, Sweep=auto
4. Mark the peak frequency and -6dB (upper and lower) frequency.
5. Repeat above procedures until all frequency measured were complete.

**Refer to section D of KDB Document: KDB 789033 D02 General UNII Test Procedures New Rules v01**

### **8.3 Measurement Equipment Used:**

Refer to section 6.3 for details.

### **8.4 Test Set-up:**

Refer to section 6.4 for details.

## 8.5 Measurement Result

### 5725-5850 MHz

#### 802.11a Mode

Frequency (MHz)	6dB Bandwidth (MHz)	Limit (KHz)
5745	16.44	>500
5785	16.44	>500
5825	16.44	>500

#### 802.11n HT20 Mode

Frequency (MHz)	6dB Bandwidth (MHz)	Limit (KHz)
5745	16.5	>500
5785	15.9	>500
5825	15.78	>500

#### 802.11n HT40 Mode

Frequency (MHz)	6dB Bandwidth (MHz)	Limit (KHz)
5755	35.9	>500
5795	36.1	>500

#### 802.11a HT80 Mode

Frequency (MHz)	6dB Bandwidth (MHz)	Limit (KHz)
5775	75.6	>500

**5725-5850 MHz**  
**802.11a**  
**6dB Band Width Test Data CH-Low**

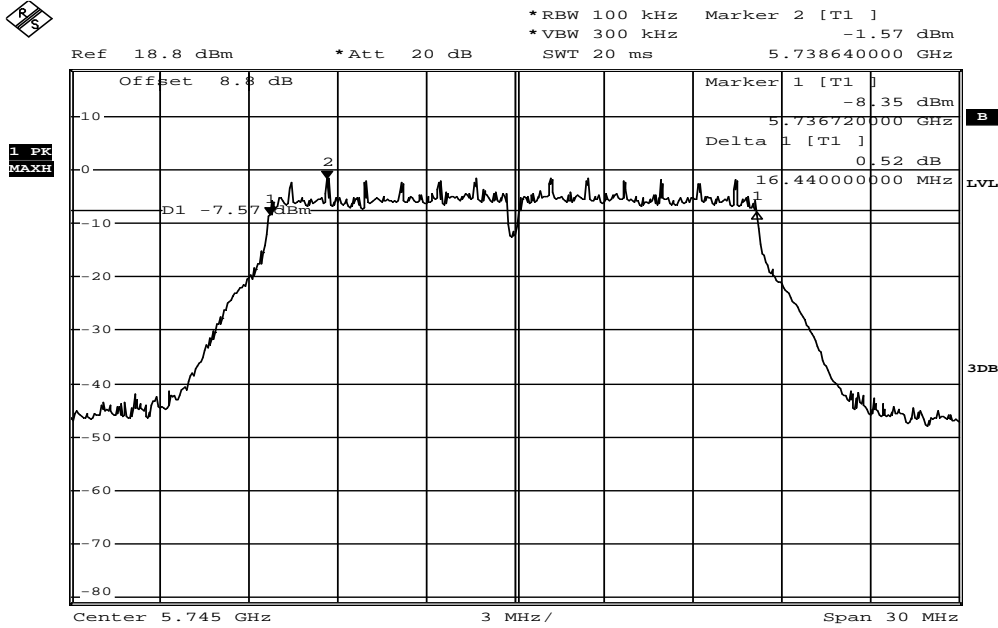

Date: 15.APR.2015 14:20:33

**6dB Band Width Test Data CH-Mid**

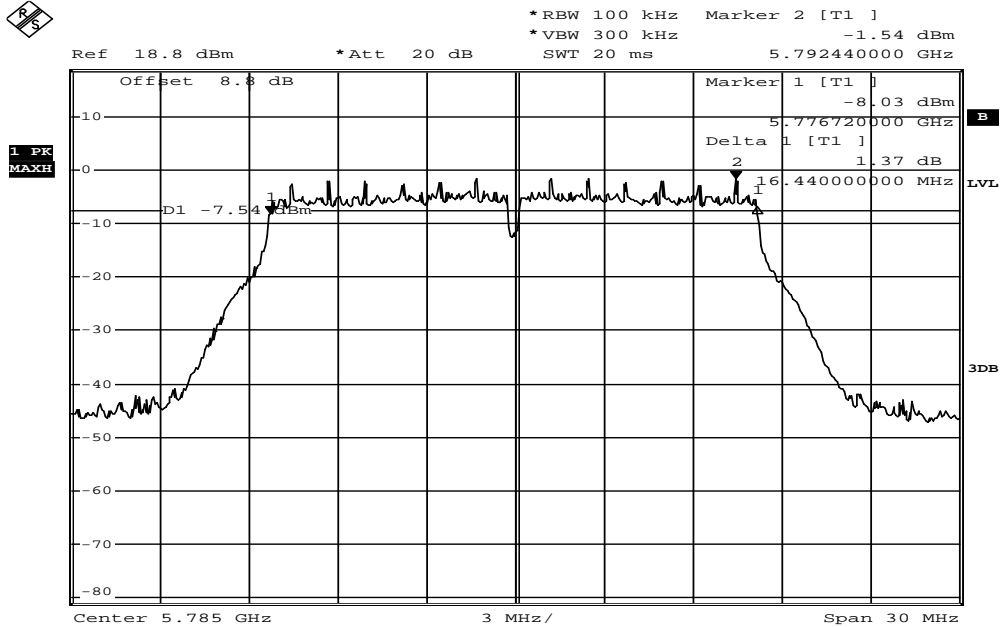

Date: 15.APR.2015 14:19:12

### 6dB Band Width Test Data CH-High

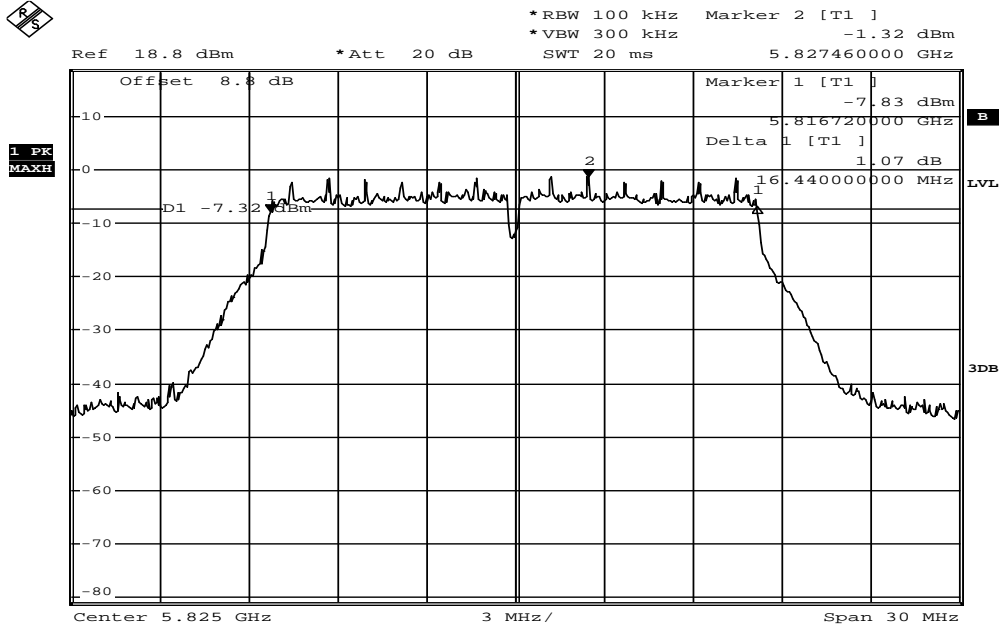

Date: 15.APR.2015 14:17:27

### 802.11n HT20

### 6dB Band Width Test Data CH-Low

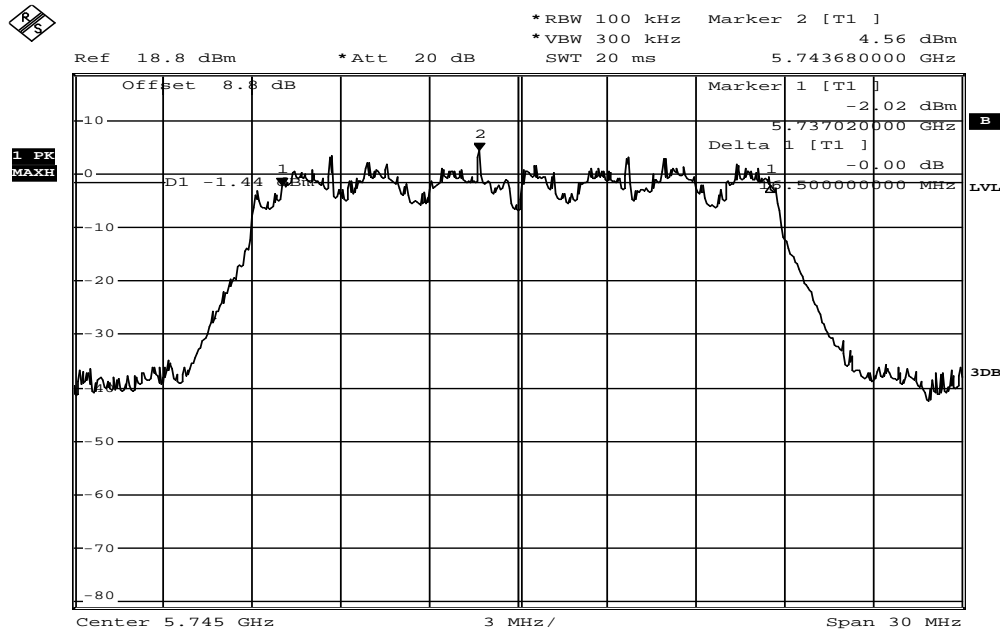

Date: 15.APR.2015 14:10:19

### 6dB Band Width Test Data CH-Mid

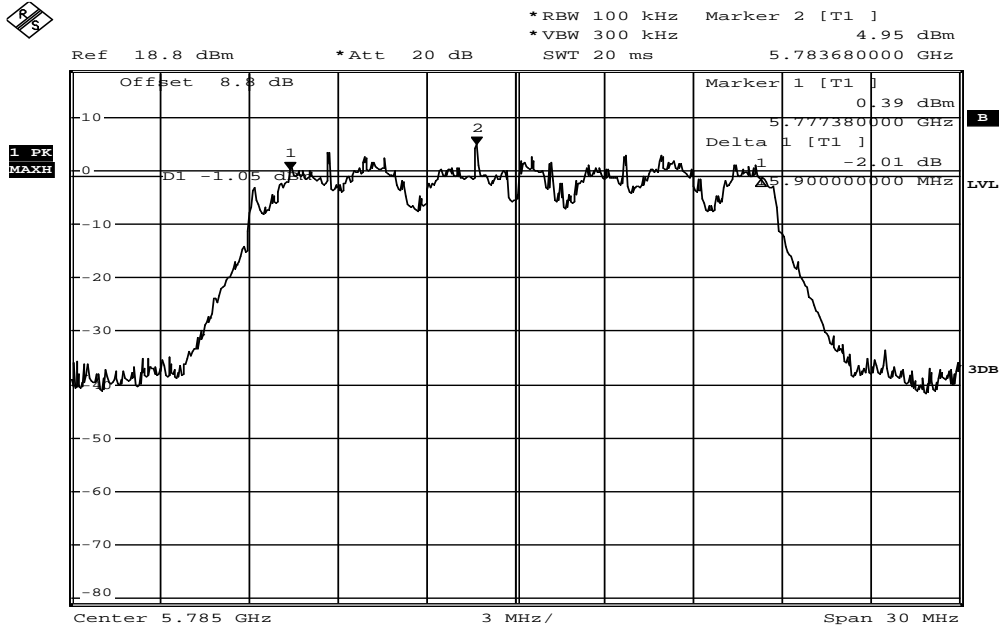

Date: 15.APR.2015 14:12:04

### 6dB Band Width Test Data CH-High

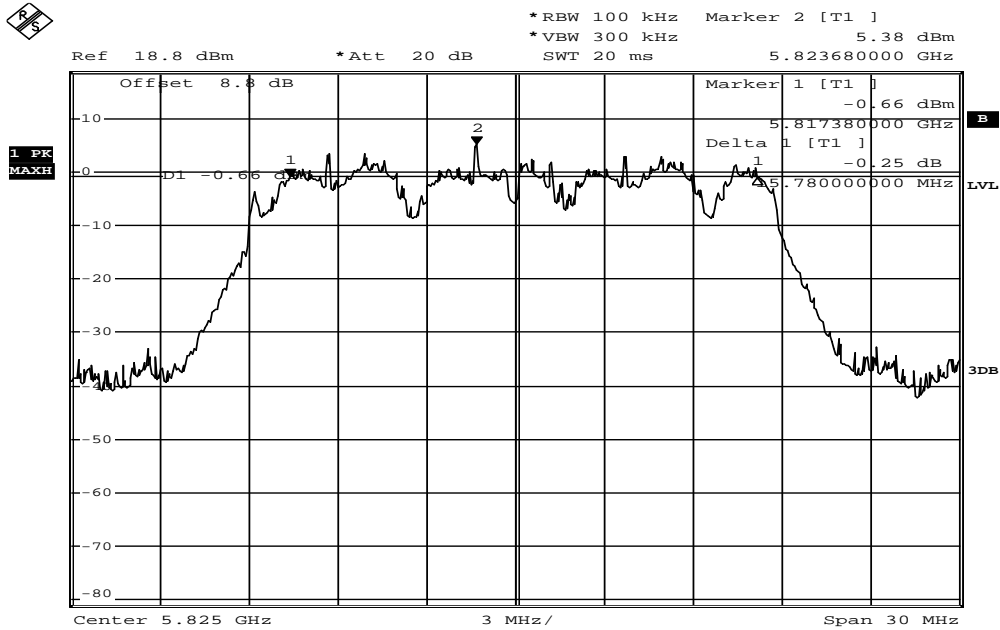

Date: 15.APR.2015 14:14:32

### 802.11n HT40 6dB Band Width Test Data CH-Low

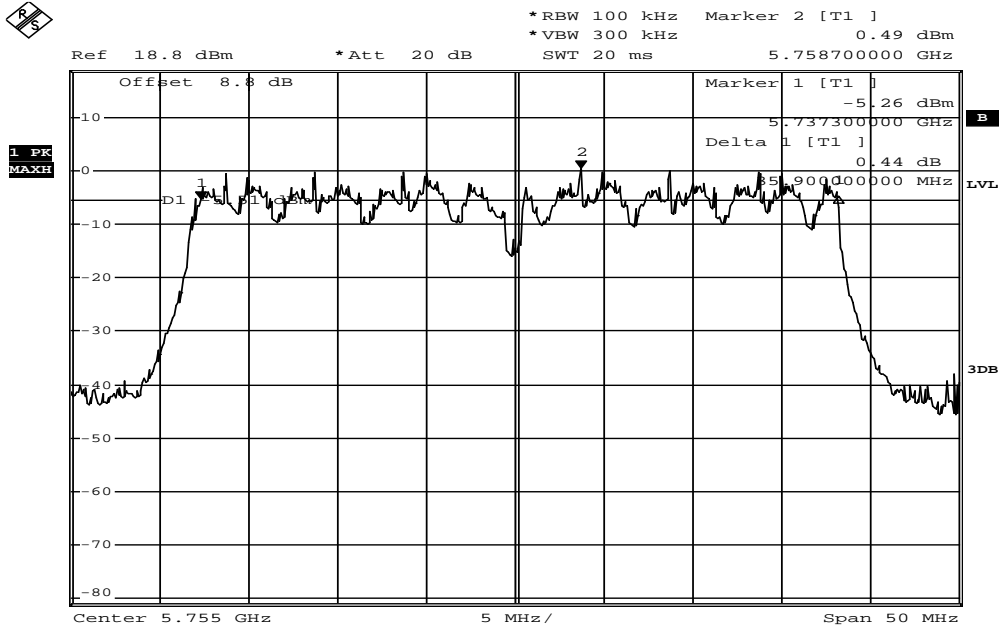

Date: 15.APR.2015 14:04:16

### 6dB Band Width Test Data CH-High

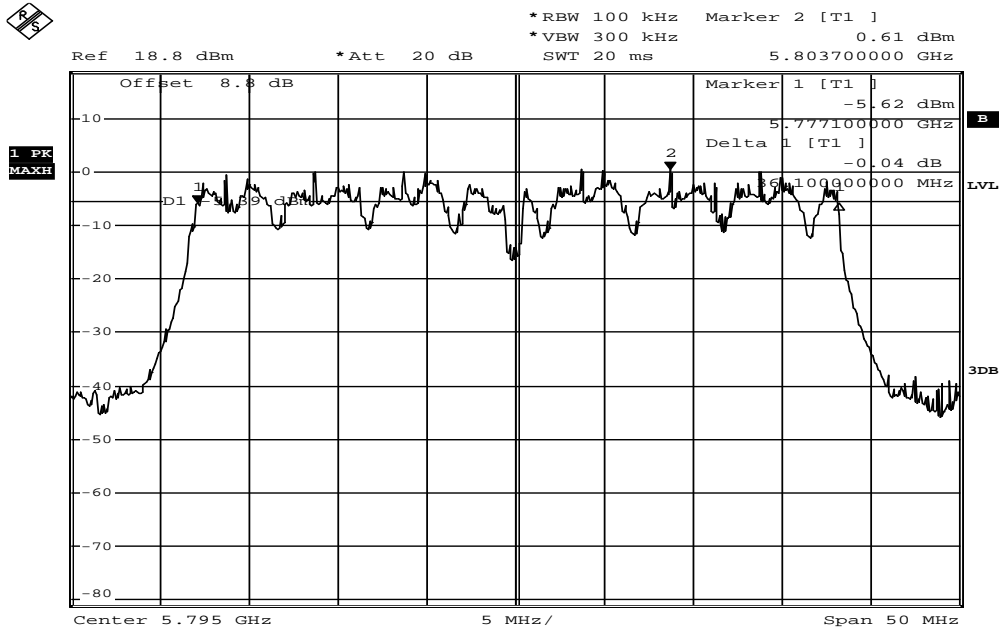

Date: 15.APR.2015 14:05:22



**802.11AC HT80**  
**6dB Band Width Test Data CH-Low**

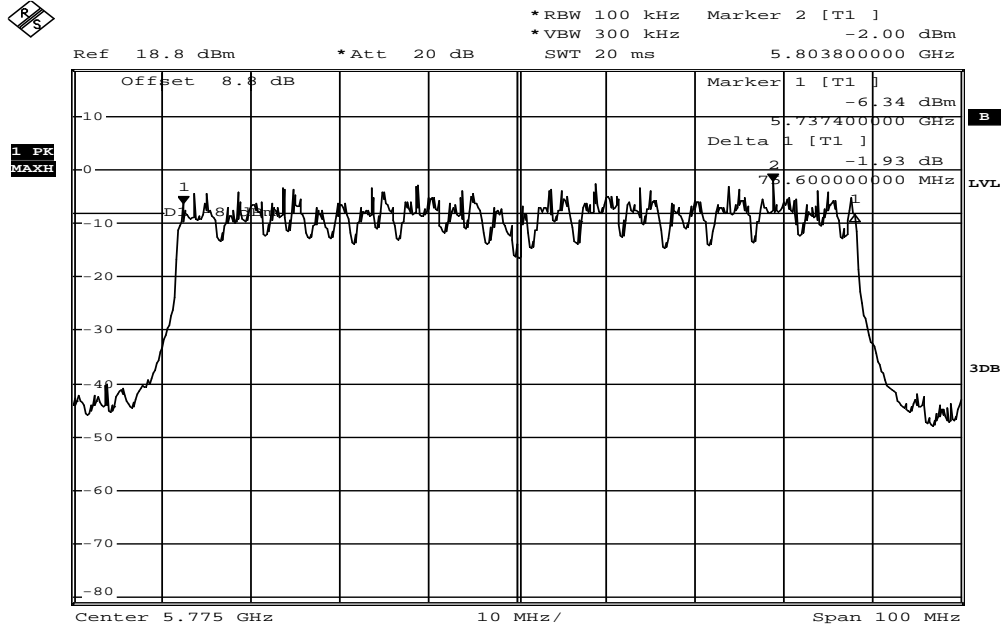

Date: 15.APR.2015 14:01:54

## 9. UNDESIRABLE EMISSION - RADICTED MEASUREMENT

### 9.1 Standard Applicable

#### According to §15.407(b),

According to §15.407(b), Undesirable Emission Limits: Except as shown in Paragraph (b)(7) of this section, the peak emissions outside of the frequency bands of operation shall be attenuated in accordance with the following limits:

- (1) For transmitters operating in the 5.15-5.25 GHz band: all emissions outside of the 5.15-5.35 GHz band shall not exceed an e.i.r.p. of -27 dBm/MHz.
- (2) For transmitters operating in the 5.25-5.35 GHz band: all emissions outside of the 5.15-5.35 GHz band shall not exceed an e.i.r.p. of -27 dBm/MHz.
- (3) For transmitters operating in the 5.47-5.725 GHz band: all emissions outside of the 5.47-5.725 GHz band shall not exceed an e.i.r.p. of -27 dBm/MHz.
- (4) For transmitters operating in the 5.725-5.85 GHz band: all emissions within the frequency range from the band edge to 10 MHz above or below the band edge shall not exceed an e.i.r.p. of -17dBm/MHz; for frequencies 10 MHz or greater above or below the band edge, emissions shall not exceed an e.i.r.p. of -27 dBm/MHz.
- (5) The above emission measurements shall be performed using a minimum resolution bandwidth of 1 MHz. A lower resolution bandwidth may be employed near the band edge, when necessary, provided the measured energy is integrated to show the total power over 1 MHz.
- (6) Unwanted emissions below 1 GHz must comply with the general field strength limits set forth in Section 15.209. Further, any U-NII devices using an AC power line are required to comply also with the conducted limits set forth in Section 15.207.
- (7) The provisions of Section 15.205 of this part apply to intentional radiators operating under this section.
- (8) When measuring the emission limits, the nominal carrier frequency shall be adjusted as close to the upper and lower frequency band edges as the design of the equipment permits.

**§15.205- RESTRICTED BANDS OF OPERATIONS**

(a) Except as shown in paragraph (d) of this section, only spurious emissions are permitted in any of the frequency bands listed below:

MHz	MHz	MHz	GHz
0.090 - 0.110	16.42 - 16.423	399.9 - 410	4.5 - 5.15
<sup>1</sup> 0.495 - 0.505	16.69475 - 16.69525	608 - 614	5.35 - 5.46
2.1735 - 2.1905	16.80425 - 16.80475	960 - 1240	7.25 - 7.75
4.125 - 4.128	25.5 - 25.67	1300 - 1427	8.025 - 8.5
4.17725 - 4.17775	37.5 - 38.25	1435 - 1626.5	9.0 - 9.2
4.20725 - 4.20775	73 - 74.6	1645.5 - 1646.5	9.3 - 9.5
6.215 - 6.218	74.8 - 75.2	1660 - 1710	10.6 - 12.7
6.26775 - 6.26825	108 - 121.94	1718.8 - 1722.2	13.25 - 13.4
6.31175 - 6.31225	123 - 138	2200 - 2300	14.47 - 14.5
8.291 - 8.294	149.9 - 150.05	2310 - 2390	15.35 - 16.2
8.362 - 8.366	156.52475 -	2483.5 - 2500	17.7 - 21.4
8.37625 - 8.38675	156.52525	2655 - 2900	22.01 - 23.12
8.41425 - 8.41475	156.7 - 156.9	3260 - 3267	23.6 - 24.0
12.29 - 12.293	162.0125 - 167.17	3332 - 3339	31.2 - 31.8
12.51975 - 12.52025	167.72 - 173.2	3345.8 - 3358	36.43 - 36.5
12.57675 - 12.57725	240 - 285	3600 - 4400	( <sup>2</sup> )
13.36 - 13.41	322 - 335.4		

<sup>1</sup> Until February 1, 1999, this restricted band shall be 0.490-0.510 MHz.

<sup>2</sup> Above 38.6

(b) Except as provided in paragraphs (d) and (e), the field strength of emissions appearing within these frequency bands shall not exceed the limits shown in Section 15.209. At frequencies equal to or less than 1000 MHz, compliance with the limits in Section 15.209 shall be demonstrated using measurement instrumentation employing a CISPR quasi-peak detector. Above 1000 MHz, compliance with the emission limits in Section 15.209 shall be demonstrated based on the average value of the measured emissions. The provisions in Section 15.35 apply to these measurements.

**§15.209- RADIATED EMISSION LIMITS: GENERAL REQUIREMENTS**

FCC PART 15.209

MEASURING DISTANCE OF 3 METER		
FREQUENCY RANGE (MHz)	FIELD STRENGTH (Microvolts/m)	FIELD STRENGTH (dBuV/m)
30-88	100	40
88-216	150	43.5
216-960	200	46
Above 960	500	54

**9.2 EUT Setup**

1. The radiated emission tests were performed in the 3 meter open-test site, using the setup in accordance with the ANSI C63.4-2009.
2. The EUT was put in the front of the test table. The host PC system was placed on the center of the back edge on the test table. The peripherals like modem, monitor printer, K/B, and mouse were placed on the side of the host PC system. The rear of the EUT and peripherals were placed flushed with the rear of the tabletop.
3. The keyboard was placed directly in the front of the monitor, flushed with the front tabletop. The mouse was placed next to the Keyboard, flushed with the back of keyboard.
4. The spacing between the peripherals was 10 centimeters.
5. External I/O cables were draped along the edge of the test table and bundle when necessary.
6. The host PC system was connected with 120Vac/60Hz power source.

### 9.3 Measurement Procedure

1. The EUT was placed on a turn table which is 0.8m above ground plane.
2. The turn table shall rotate 360 degrees to determine the position of maximum emission level.
3. EUT is set 3m away from the receiving antenna which varied from 1m to 4m to find out the highest emissions.
4. Maximum procedure was performed on the six highest emissions to ensure EUT compliance.
5. And also, each emission was to be maximized by changing the polarization of receiving antenna both horizontal and vertical.
6. Repeat above procedures until all frequency measured were complete.

**Refer to section G of KDB Document: KDB 789033 D02 General UNII Test Procedures New Rules v01**

**9.4 Test SET-UP (Block Diagram of Configuration)**

(A) Radiated Emission Test Set-Up, Frequency Below 1000MHz

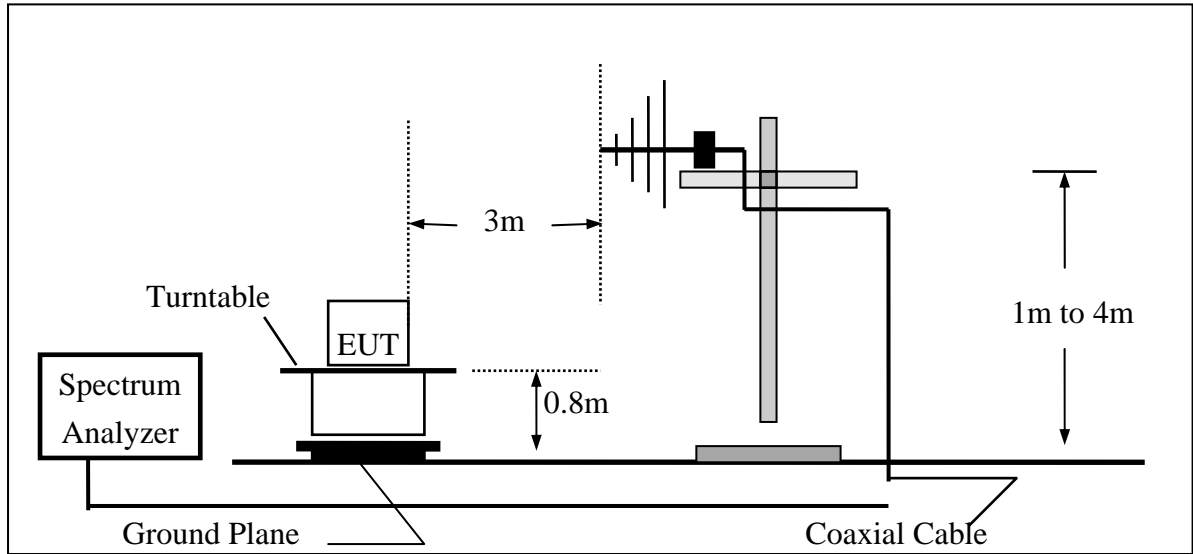

(B) Radiated Emission Test Set-Up Frequency Over 1 GHz

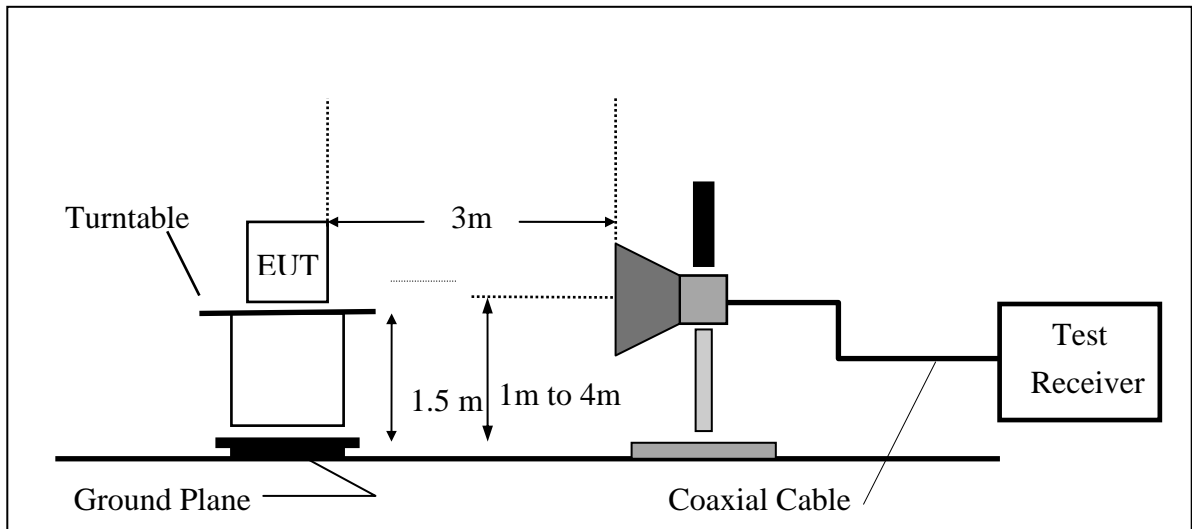

### 9.5 Measurement Equipment Used:

Chamber 14(966)					
EQUIPMENT TYPE	MFR	MODEL NUMBER	SERIAL NUMBER	LAST CAL.	CAL DUE.
Spectrum Analyzer 21(26.5GHz)	Agilent	N9010A	MY49060537	07/29/2014	07/28/2015
Spectrum Analyzer 20(6.5GHz)	Agilent	E4443A	MY48250315	05/26/2014	05/25/2015
Spectrum Analyzer 22(43GHz)	R&S	FSU43	100143	05/07/2015	05/06/2016
Dipole antenna	SCHWARZBECK	VHAP,30-300	919	12/03/2013	12/02/2015
Dipole antenna	SCHWARZBECK	UHAP,300-1000	1195	12/03/2013	12/02/2015
Loop Antenna9K-30M	A.H.SYSTEM	SAS-564	294	03/07/2015	03/06/2017
Bilog Antenna30-1G	Schaffner	CBL 6112B	2756	12/30/2014	12/29/2015
Horn antenna1-18G	ETS	3117	00066665	11/27/2014	11/26/2015
Horn antenna26-40G(05)	Com-power	AH-640	100A	01/21/2015	01/20/2017
Horn antenna18-26G(04)	Com-power	AH-826	081001	05/15/2015	05/14/2017
Preamplifier9-1000M	HP	8447D	NA	03/12/2015	03/11/2016
Preamplifier1-18G	MITEQ	AFS44-00101800-25-10P-44	1329256	07/30/2014	07/29/2015
Preamplifier1-26G	EM	EM01M26G	NA	03/11/2015	03/10/2016
Preamplifier26-40G	MITEQ	JS-26004000-27-5A	818471	05/08/2015	05/07/2017
Cable1-18G	HUBER SUHNER	Sucoflex 106	NA	12/02/2014	12/01/2015
Cable UP to 1G	HUBER SUHNER	RG 214/U	NA	10/17/2014	10/16/2015
SUCOFLEX 1GHz~40GHz cable	HUBER SUHNER	Sucoflex 102	27963/2&37421/2	10/03/2013	10/02/2015
Signal Generator	R&S	SMU200A	102330	03/11/2015	02/10/2016
Signal Generator	Anritsu	MG3692A	20311	10/29/2014	10/28/2015
2.4G Filter	Micro-Tronics	Brm50702	76	12/27/2014	12/26/2015
5G Filter	Micro-Tronics	Brm50716	005	12/27/2014	12/26/2015

## 9.6 Field Strength Calculation

The field strength is calculated by adding the Antenna Factor and Cable Factor and subtracting the Amplifier Gain and Duty Cycle Correction Factor(if any) from the measured reading. The basic equation with a sample calculation is as follows:

$$FS = RA + AF + CL - AG$$

Where	FS = Field Strength	CL = Cable Attenuation Factor (Cable Loss)
	RA = Reading Amplitude	AG = Amplifier Gain
	AF = Antenna Factor	

## 9.7 Measurement Result

Refer to attach tabular data sheets.

### NOTE:

The resolution bandwidth and video bandwidth of test receiver/spectrum analyzer is 100kHz for Peak detection (PK) and Quasi-peak detection (QP) at frequency below 1GHz. And RBW 1MHz for frequency above1GHz.



**Radiated Spurious Emission Measurement Result (below 1GHz) (worst case)**

Operation Mode	802.11n HT20 TX CH Low	Test Date	2015/04/27
Fundamental Frequency	5170MHz	Test By	Dino
Temperature	25 °C	Pol	Ver./Hor
Humidity	65 %		

No	Freq MHz	Reading dBuV	Factor dB	Level dBuV/m	Limit dBuV/m	Over Limit dB	Remark	Pol V/H
1	106.63	46.55	-16.47	30.08	43.50	-13.42	Peak	VERTICAL
2	250.19	46.19	-12.89	33.30	46.00	-12.70	Peak	VERTICAL
3	399.57	37.11	-9.19	27.92	46.00	-18.08	Peak	VERTICAL
4	500.45	34.83	-7.45	27.38	46.00	-18.62	Peak	VERTICAL
5	600.36	34.69	-5.57	29.12	46.00	-16.88	Peak	VERTICAL
6	833.16	35.89	-1.69	34.20	46.00	-11.80	Peak	VERTICAL
1	84.32	49.79	-17.75	32.04	40.00	-7.96	Peak	HORIZONTAL
2	250.19	46.24	-12.89	33.35	46.00	-12.65	Peak	HORIZONTAL
3	350.10	37.58	-10.11	27.47	46.00	-18.53	Peak	HORIZONTAL
4	500.45	37.91	-7.45	30.46	46.00	-15.54	Peak	HORIZONTAL
5	600.36	38.05	-5.57	32.48	46.00	-13.52	Peak	HORIZONTAL
6	700.27	36.43	-4.02	32.41	46.00	-13.59	Peak	HORIZONTAL

Remark:

- 1 No further spurious emissions detected from the lowest internal frequency and 30MHz.
- 2 Measuring frequencies from the lowest internal frequency to the 1GHz.
- 3 Radiated emissions measured in frequency range from 9MHz to 1000MHz were made with an instrument detector setting 9-90KHz/110-490KHz using PK/AV and other Frequency Band using PK/QP
- 4 Measurement result within this frequency range shown “ - ” in the table above means the reading of emissions are attenuated more than 20dB below the permissible limits or the field strength is too small to be measured.
- 5 The IF bandwidth of SPA between 9kHz to 30MHz was 10kHz, VBW= 30kHz; between 30MHz to 1GHz was 100KHz, VBW=300KHz.

**Radiated Spurious Emission Measurement Result (below 1GHz)**

Operation Mode	802.11n HT20 TX CH Mid	Test Date	2015/04/27
Fundamental Frequency	5200MHz	Test By	Dino
Temperature	25 °C	Pol	Ver./Hor
Humidity	65 %		

No	Freq MHz	Reading dBuV	Factor dB	Level dBuV/m	Limit dBuV/m	Over Limit dB	Remark	Pol V/H
1	106.63	46.46	-16.47	29.99	43.50	-13.51	Peak	VERTICAL
2	250.19	46.09	-12.89	33.20	46.00	-12.80	Peak	VERTICAL
3	398.60	39.17	-9.20	29.97	46.00	-16.03	Peak	VERTICAL
4	500.45	35.21	-7.45	27.76	46.00	-18.24	Peak	VERTICAL
5	600.36	34.38	-5.57	28.81	46.00	-17.19	Peak	VERTICAL
6	833.16	36.03	-1.69	34.34	46.00	-11.66	Peak	VERTICAL
1	83.35	48.90	-17.57	31.33	40.00	-8.67	Peak	HORIZONTAL
2	250.19	46.02	-12.89	33.13	46.00	-12.87	Peak	HORIZONTAL
3	350.10	37.49	-10.11	27.38	46.00	-18.62	Peak	HORIZONTAL
4	500.45	38.09	-7.45	30.64	46.00	-15.36	Peak	HORIZONTAL
5	600.36	37.92	-5.57	32.35	46.00	-13.65	Peak	HORIZONTAL
6	700.27	36.03	-4.02	32.01	46.00	-13.99	Peak	HORIZONTAL

Remark:

- 1 No further spurious emissions detected from the lowest internal frequency and 30MHz.
- 2 Measuring frequencies from the lowest internal frequency to the 1GHz.
- 3 Radiated emissions measured in frequency range from 9MHz to 1000MHz were made with an instrument detector setting 9-90KHz/110-490KHz using PK/AV and other Frequency Band using PK/QP
- 4 Measurement result within this frequency range shown “ - ” in the table above means the reading of emissions are attenuated more than 20dB below the permissible limits or the field strength is too small to be measured.
- 5 The IF bandwidth of SPA between 9kHz to 30MHz was 10kHz, VBW= 30kHz; between 30MHz to 1GHz was 100KHz, VBW=300KHz.

**Radiated Spurious Emission Measurement Result (below 1GHz)**

Operation Mode	802.11n HT20 TX CH High	Test Date	2015/04/27
Fundamental Frequency	5240MHz	Test By	Dino
Temperature	25 °C	Pol	Ver./Hor
Humidity	65 %		

No	Freq MHz	Reading dBuV	Factor dB	Level dBuV/m	Limit dBuV/m	Over Limit dB	Remark	Pol V/H
1	106.63	45.51	-16.47	29.04	43.50	-14.46	Peak	VERTICAL
2	250.19	46.71	-12.89	33.82	46.00	-12.18	Peak	VERTICAL
3	392.78	38.13	-9.32	28.81	46.00	-17.19	Peak	VERTICAL
4	500.45	35.28	-7.45	27.83	46.00	-18.17	Peak	VERTICAL
5	600.36	35.39	-5.57	29.82	46.00	-16.18	Peak	VERTICAL
6	833.16	36.52	-1.69	34.83	46.00	-11.17	Peak	VERTICAL
1	84.32	49.62	-17.75	31.87	40.00	-8.13	Peak	HORIZONTAL
2	183.26	45.77	-13.88	31.89	43.50	-11.61	Peak	HORIZONTAL
3	250.19	46.10	-12.89	33.21	46.00	-12.79	Peak	HORIZONTAL
4	350.10	36.36	-10.11	26.25	46.00	-19.75	Peak	HORIZONTAL
5	500.45	38.20	-7.45	30.75	46.00	-15.25	Peak	HORIZONTAL
6	600.36	37.26	-5.57	31.69	46.00	-14.31	Peak	HORIZONTAL

Remark:

- 1 No further spurious emissions detected from the lowest internal frequency and 30MHz.
- 2 Measuring frequencies from the lowest internal frequency to the 1GHz.
- 3 Radiated emissions measured in frequency range from 9MHz to 1000MHz were made with an instrument detector setting 9-90KHz/110-490KHz using PK/AV and other Frequency Band using PK/QP
- 4 Measurement result within this frequency range shown “ - ” in the table above means the reading of emissions are attenuated more than 20dB below the permissible limits or the field strength is too small to be measured.
- 5 The IF bandwidth of SPA between 9kHz to 30MHz was 10kHz, VBW= 30kHz; between 30MHz to 1GHz was 100KHz, VBW=300KHz.

**Radiated Spurious Emission Measurement Result (above 1GHz) (worst case)**

Operation Mode	802.11n HT20 TX CH Low	Test Date	2015/04/27
Fundamental Frequency	5170MHz	Test By	Dino
Temperature	25 °C	Humidity	60 %

No	Freq MHz	Reading dBuV	Factor dB	Level dBuV/m	Limit dBuV/m	Over Limit dB	Remark	Pol V/H
1	3828.00	48.17	-6.40	41.77	74.00	-32.23	Peak	VERTICAL
2	11490.00	30.83	7.86	38.69	74.00	-35.31	Peak	VERTICAL
3	13960.00	31.71	12.07	43.78	74.00	-30.22	Peak	VERTICAL
1	2001.00	49.00	-12.14	36.86	74.00	-37.14	Peak	HORIZONTAL
2	11490.00	31.44	7.86	39.30	74.00	-34.70	Peak	HORIZONTAL
3	13970.00	31.47	12.11	43.58	74.00	-30.42	Peak	HORIZONTAL

Remark:

- 1 Measuring frequencies from the lowest internal frequency to the 10th of fundamental frequency
- 2 Field strength limits for frequency above 1000MHz are based on average limits. However, Peak mode field strength shall not exceed the average limits specified plus 20dB.
- 3 Measurement of data within this frequency range shown “ - ” in the table above means the reading of emissions are attenuated more than 20dB below the permissible limits or the field strength is too small to be measured.
- 4 Spectrum Peak mode IF bandwidth Setting : 1GHz- 26GHz, RBW= 1MHz, Sweep time= 200 ms., the VBW setting was 3 MHz.
- 5 Spectrum AV mode if bandwidth Setting : 1GHz- 26GHz, RBW= 1MHz, VBW= 10Hz, Sweep time= 200 ms.

**Radiated Spurious Emission Measurement Result (above 1GHz) (worst case)**

Operation Mode	802.11n HT20 TX CH Mid	Test Date	2015/04/27
Fundamental Frequency	5200MHz	Test By	Dino
Temperature	25 °C	Humidity	60 %

No	Freq MHz	Reading dBuV	Factor dB	Level dBuV/m	Limit dBuV/m	Over Limit dB	Remark	Pol V/H
1	3856.00	46.94	-6.27	40.67	74.00	-33.33	Peak	VERTICAL
2	11560.00	32.12	7.82	39.94	74.00	-34.06	Peak	VERTICAL
3	13980.00	31.79	12.13	43.92	74.00	-30.08	Peak	VERTICAL
1	2001.00	49.50	-12.14	37.36	74.00	-36.64	Peak	HORIZONTAL
2	11560.00	30.80	7.82	38.62	74.00	-35.38	Peak	HORIZONTAL
3	14060.00	30.80	12.23	43.03	74.00	-30.97	Peak	HORIZONTAL

Remark:

- 1 Measuring frequencies from the lowest internal frequency to the 10th of fundamental frequency
- 2 Field strength limits for frequency above 1000MHz are based on average limits. However, Peak mode field strength shall not exceed the average limits specified plus 20dB.
- 3 Measurement of data within this frequency range shown “ - ” in the table above means the reading of emissions are attenuated more than 20dB below the permissible limits or the field strength is too small to be measured.
- 4 Spectrum Peak mode IF bandwidth Setting : 1GHz- 26GHz, RBW= 1MHz, Sweep time= 200 ms., the VBW setting was 3 MHz.
- 5 Spectrum AV mode if bandwidth Setting : 1GHz- 26GHz, RBW= 1MHz, VBW= 10Hz, Sweep time= 200 ms.

**Radiated Spurious Emission Measurement Result (above 1GHz) (worst case)**

Operation Mode	802.11n HT20 TX CH High	Test Date	2015/04/27
Fundamental Frequency	5240MHz	Test By	Dino
Temperature	25 °C	Humidity	60 %

No	Freq MHz	Reading dBuV	Factor dB	Level dBuV/m	Limit dBuV/m	Over Limit dB	Remark	Pol V/H
1	1994.00	55.40	-12.17	43.23	74.00	-30.77	Peak	VERTICAL
2	11650.00	31.70	7.79	39.49	74.00	-34.51	Peak	VERTICAL
3	13980.00	31.96	12.13	44.09	74.00	-29.91	Peak	VERTICAL
1	2001.00	48.69	-12.14	36.55	74.00	-37.45	Peak	HORIZONTAL
2	11650.00	29.91	7.79	37.70	74.00	-36.30	Peak	HORIZONTAL
3	13960.00	31.86	12.07	43.93	74.00	-30.07	Peak	HORIZONTAL

Remark:

- 1 Measuring frequencies from the lowest internal frequency to the 10th of fundamental frequency
- 2 Field strength limits for frequency above 1000MHz are based on average limits. However, Peak mode field strength shall not exceed the average limits specified plus 20dB.
- 3 Measurement of data within this frequency range shown “ - ” in the table above means the reading of emissions are attenuated more than 20dB below the permissible limits or the field strength is too small to be measured.
- 4 Spectrum Peak mode IF bandwidth Setting : 1GHz- 26GHz, RBW= 1MHz, Sweep time= 200 ms., the VBW setting was 3 MHz.
- 5 Spectrum AV mode if bandwidth Setting : 1GHz- 26GHz, RBW= 1MHz, VBW= 10Hz, Sweep time= 200 ms.

**Band Edges test**

**5150MHz – 5250MHz**

**Radiated Emission: 802.11a mode**

Operation Mode	TX CH Low	Test Date	2015/04/27
Fundamental Frequency	5170 MHz	Test By	Dino
Temperature	25 °C	Humidity	65 %

No	Freq MHz	Reading dBuV	Factor dB	Level dBuV/m	Limit dBuV/m	Over Limit dB	Remark	Pol V/H
1	5084.50	56.37	-2.55	53.82	74.00	-20.18	Peak	VERTICAL
2	5095.00	56.29	-2.52	53.77	74.00	-20.23	Peak	VERTICAL
3	5150.00	54.30	-2.40	51.90	54.00	-2.10	Average	VERTICAL
4	5150.00	65.44	-2.40	63.04	74.00	-10.96	Peak	VERTICAL
1	5150.00	53.10	-2.40	50.70	74.00	-23.30	Peak	HORIZONTAL

Operation Mode	TX CH High	Test Date	2015/04/27
Fundamental Frequency	5240MHz	Test By	Dino
Temperature	25 °C	Humidity	65 %

No	Freq MHz	Reading dBuV	Factor dB	Level dBuV/m	Limit dBuV/m	Over Limit dB	Remark	Pol V/H
1	5350.00	45.57	-1.94	43.63	74.00	-30.37	Peak	VERTICAL
2	5352.84	49.75	-1.93	47.82	74.00	-26.18	Peak	VERTICAL
1	5350.00	42.42	-1.94	40.48	74.00	-33.52	Peak	HORIZONTAL
2	5355.54	45.77	-1.92	43.85	74.00	-30.15	Peak	HORIZONTAL

Remark:

- 1 Measuring frequencies from the lowest internal frequency to the 10th of fundamental frequency
- 2 Field strength limits for frequency above 1000MHz are based on average limits. However, Peak mode field strength shall not exceed the average limits specified plus 20dB.
- 3 Measurement of data within this frequency range shown “ - ” in the table above means the reading of emissions are attenuated more than 20dB below the permissible limits or the field strength is too small to be measured.
- 4 Spectrum Peak mode IF bandwidth Setting : 1GHz- 26GHz, RBW= 1MHz, Sweep time= 200 ms., the VBW setting was 3 MHz.
- 5 Spectrum AV mode if bandwidth Setting : 1GHz- 26GHz, RBW= 1MHz, VBW= 10Hz, Sweep time= 200 ms.

**Radiated Emission: 802.11n HT20 mode, Combine**

Operation Mode	TX CH Low	Test Date	2015/04/27
Fundamental Frequency	5170 MHz	Test By	Dino
Temperature	25 °C	Humidity	65 %

No	Freq MHz	Reading dBuV	Factor dB	Level dBuV/m	Limit dBuV/m	Over Limit dB	Remark	Pol V/H
1	5150.00	54.18	-2.40	51.78	54.00	-2.22	Average	VERTICAL
2	5150.00	69.18	-2.40	66.78	74.00	-7.22	Peak	VERTICAL
1	5150.00	56.15	-2.40	53.75	74.00	-20.25	Peak	HORIZONTAL

Operation Mode	TX CH High	Test Date	2015/04/27
Fundamental Frequency	5240MHz	Test By	Dino
Temperature	25 °C	Humidity	65 %

No	Freq MHz	Reading dBuV	Factor dB	Level dBuV/m	Limit dBuV/m	Over Limit dB	Remark	Pol V/H
1	5350.00	45.11	-1.94	43.17	74.00	-30.83	Peak	VERTICAL
2	5357.88	50.59	-1.92	48.67	74.00	-25.33	Peak	VERTICAL
1	5350.00	43.61	-1.94	41.67	74.00	-32.33	Peak	HORIZONTAL

Remark:

- 1 Measuring frequencies from the lowest internal frequency to the 10th of fundamental frequency
- 2 Field strength limits for frequency above 1000MHz are based on average limits. However, Peak mode field strength shall not exceed the average limits specified plus 20dB.
- 3 Measurement of data within this frequency range shown “ - ” in the table above means the reading of emissions are attenuated more than 20dB below the permissible limits or the field strength is too small to be measured.
- 4 Spectrum Peak mode IF bandwidth Setting : 1GHz- 26GHz, RBW= 1MHz, Sweep time= 200 ms., the VBW setting was 3 MHz.
- 5 Spectrum AV mode if bandwidth Setting : 1GHz- 26GHz, RBW= 1MHz, VBW= 10Hz, Sweep time= 200 ms.



**Radiated Emission: 802.11n HT40 mode, Combine**

Operation Mode	TX CH Low	Test Date	2015/04/27
Fundamental Frequency	5190 MHz	Test By	Dino
Temperature	25 °C	Humidity	65 %

No	Freq MHz	Reading dBuV	Factor dB	Level dBuV/m	Limit dBuV/m	Over Limit dB	Remark	Pol V/H
1	5150.00	53.19	-2.40	50.79	54.00	-3.21	Average	VERTICAL
2	5150.00	71.49	-2.40	69.09	74.00	-4.91	Peak	VERTICAL
1	5150.00	50.53	-2.40	48.13	74.00	-25.87	Peak	HORIZONTAL

Operation Mode	TX CH High	Test Date	2015/04/27
Fundamental Frequency	5230MHz	Test By	Dino
Temperature	25 °C	Humidity	65 %

No	Freq MHz	Reading dBuV	Factor dB	Level dBuV/m	Limit dBuV/m	Over Limit dB	Remark	Pol V/H
1	5350.00	44.19	-1.94	42.25	74.00	-31.75	Peak	VERTICAL
2	5360.80	48.90	-1.91	46.99	74.00	-27.01	Peak	VERTICAL
1	5350.00	42.85	-1.94	40.91	74.00	-33.09	Peak	HORIZONTAL

**Remark:**

- 1 Measuring frequencies from the lowest internal frequency to the 10th of fundamental frequency
- 2 Field strength limits for frequency above 1000MHz are based on average limits. However, Peak mode field strength shall not exceed the average limits specified plus 20dB.
- 3 Measurement of data within this frequency range shown “ - ” in the table above means the reading of emissions are attenuated more than 20dB below the permissible limits or the field strength is too small to be measured.
- 4 Spectrum Peak mode IF bandwidth Setting : 1GHz- 26GHz, RBW= 1MHz, Sweep time= 200 ms., the VBW setting was 3 MHz.
- 5 Spectrum AV mode if bandwidth Setting : 1GHz- 26GHz, RBW= 1MHz, VBW= 10Hz, Sweep time= 200 ms.

**Radiated Emission: 802.11AC HT80 mode, Combine**

Operation Mode	TX CH Low	Test Date	2015/04/27
Fundamental Frequency	5210 MHz	Test By	Dino
Temperature	25 °C	Humidity	65 %

No	Freq MHz	Reading dBuV	Factor dB	Level dBuV/m	Limit dBuV/m	Over Limit dB	Remark	Pol V/H
1	5150.00	52.73	-2.40	50.33	54.00	-3.67	Average	VERTICAL
2	5150.00	72.94	-2.40	70.54	74.00	-3.46	Peak	VERTICAL
1	5146.76	54.79	-2.40	52.39	74.00	-21.61	Peak	HORIZONTAL
2	5150.00	51.01	-2.40	48.61	74.00	-25.39	Peak	HORIZONTAL

Operation Mode	TX CH High	Test Date	2015/04/27
Fundamental Frequency	5210MHz	Test By	Dino
Temperature	25 °C	Humidity	65 %

No	Freq MHz	Reading dBuV	Factor dB	Level dBuV/m	Limit dBuV/m	Over Limit dB	Remark	Pol V/H
1	5350.00	47.85	-1.94	45.91	74.00	-28.09	Peak	VERTICAL
1	5350.00	42.03	-1.94	40.09	74.00	-33.91	Peak	HORIZONTAL

Remark:

- 1 Measuring frequencies from the lowest internal frequency to the 10th of fundamental frequency
- 2 Field strength limits for frequency above 1000MHz are based on average limits. However, Peak mode field strength shall not exceed the average limits specified plus 20dB.
- 3 Measurement of data within this frequency range shown “ - ” in the table above means the reading of emissions are attenuated more than 20dB below the permissible limits or the field strength is too small to be measured.
- 4 Spectrum Peak mode IF bandwidth Setting : 1GHz- 26GHz, RBW= 1MHz, Sweep time= 200 ms., the VBW setting was 3 MHz.
- 5 Spectrum AV mode if bandwidth Setting : 1GHz- 26GHz, RBW= 1MHz, VBW= 10Hz, Sweep time= 200 ms.

**Band Edges test**

**5725MHz – 5850MHz**

**Radiated Emission: 802.11a mode**

Operation Mode	TX CH Low	Test Date	2015/04/27
Fundamental Frequency	5745 MHz	Test By	Dino
Temperature	25 °C	Humidity	65 %

No	Freq MHz	Reading dBuV	Factor dB	Level dBuV/m	Limit dBuV/m	Over Limit dB	Remark	Pol V/H
1	5725.00	53.14	-0.99	52.15	54.00	-1.85	Average	VERTICAL
2	5725.00	68.31	-0.99	67.32	74.00	-6.68	Peak	VERTICAL
1	5725.00	48.27	-0.99	47.28	54.00	-6.72	Average	HORIZONTAL
2	5725.00	62.92	-0.99	61.93	74.00	-12.07	Peak	HORIZONTAL

Operation Mode	TX CH High	Test Date	2015/04/27
Fundamental Frequency	5825MHz	Test By	Dino
Temperature	25 °C	Humidity	65 %

No	Freq MHz	Reading dBuV	Factor dB	Level dBuV/m	Limit dBuV/m	Over Limit dB	Remark	Pol V/H
1	5850.00	47.54	-0.65	46.89	54.00	-7.11	Average	VERTICAL
2	5850.00	59.83	-0.65	59.18	74.00	-14.82	Peak	VERTICAL
1	5850.00	46.95	-0.65	46.30	54.00	-7.70	Average	HORIZONTAL
2	5850.00	60.09	-0.65	59.44	74.00	-14.56	Peak	HORIZONTAL

**Remark:**

- 1 Measuring frequencies from the lowest internal frequency to the 10th of fundamental frequency
- 2 Field strength limits for frequency above 1000MHz are based on average limits. However, Peak mode field strength shall not exceed the average limits specified plus 20dB.
- 3 Measurement of data within this frequency range shown “ - ” in the table above means the reading of emissions are attenuated more than 20dB below the permissible limits or the field strength is too small to be measured.
- 4 Spectrum Peak mode IF bandwidth Setting : 1GHz- 26GHz, RBW= 1MHz, Sweep time= 200 ms., the VBW setting was 3 MHz.
- 5 Spectrum AV mode if bandwidth Setting : 1GHz- 26GHz, RBW= 1MHz, VBW= 10Hz, Sweep time= 200 ms.

**Radiated Emission: 802.11n HT20 mode, Combine**

Operation Mode	TX CH Low	Test Date	2015/04/27
Fundamental Frequency	5745 MHz	Test By	Dino
Temperature	25 °C	Humidity	65 %

No	Freq MHz	Reading dBuV	Factor dB	Level dBuV/m	Limit dBuV/m	Over Limit dB	Remark	Pol V/H
1	5721.24	52.19	-1.00	51.19	54.00	-2.81	Average	5721.24
2	5721.24	73.76	-1.00	72.76	74.00	-1.24	Peak	5721.24
3	5725.00	53.91	-0.99	52.92	54.00	-1.08	Average	5725.00
4	5725.00	67.73	-0.99	66.74	74.00	-7.26	Peak	5725.00
1	5725.00	47.45	-0.99	46.46	54.00	-7.54	Average	HORIZONTAL
2	5725.00	60.07	-0.99	59.08	74.00	-14.92	Peak	HORIZONTAL

Operation Mode	TX CH High	Test Date	2015/04/27
Fundamental Frequency	5825MHz	Test By	Dino
Temperature	25 °C	Humidity	65 %

No	Freq MHz	Reading dBuV	Factor dB	Level dBuV/m	Limit dBuV/m	Over Limit dB	Remark	Pol V/H
1	5850.00	48.54	-0.65	47.89	54.00	-6.11	Average	VERTICAL
2	5850.00	61.91	-0.65	61.26	74.00	-12.74	Peak	VERTICAL
1	5850.00	46.96	-0.65	46.31	54.00	-7.69	Average	HORIZONTAL
2	5850.00	59.57	-0.65	58.92	74.00	-15.08	Peak	HORIZONTAL

**Remark:**

- 1 Measuring frequencies from the lowest internal frequency to the 10th of fundamental frequency
- 2 Field strength limits for frequency above 1000MHz are based on average limits. However, Peak mode field strength shall not exceed the average limits specified plus 20dB.
- 3 Measurement of data within this frequency range shown “ - ” in the table above means the reading of emissions are attenuated more than 20dB below the permissible limits or the field strength is too small to be measured.
- 4 Spectrum Peak mode IF bandwidth Setting : 1GHz- 26GHz, RBW= 1MHz, Sweep time= 200 ms., the VBW setting was 3 MHz.
- 5 Spectrum AV mode if bandwidth Setting : 1GHz- 26GHz, RBW= 1MHz, VBW= 10Hz, Sweep time= 200 ms.

**Radiated Emission: 802.11n HT40 mode, Combine**

Operation Mode	TX CH Low	Test Date	2015/04/27
Fundamental Frequency	5755 MHz	Test By	Dino
Temperature	25 °C	Humidity	65 %

No	Freq MHz	Reading dBuV	Factor dB	Level dBuV/m	Limit dBuV/m	Over Limit dB	Remark	Pol V/H
1	5717.60	52.27	-1.00	51.27	54.00	-2.73	Average	VERTICAL
2	5717.60	72.26	-1.00	71.26	74.00	-2.74	Peak	VERTICAL
3	5725.00	53.91	-0.99	52.92	54.00	-1.08	Average	VERTICAL
4	5725.00	69.43	-0.99	68.44	74.00	-5.56	Peak	VERTICAL
1	5725.00	49.18	-0.99	48.19	54.00	-5.81	Average	HORIZONTAL
2	5725.00	60.00	-0.99	59.01	74.00	-14.99	Peak	HORIZONTAL

Operation Mode	TX CH High	Test Date	2015/04/27
Fundamental Frequency	5795MHz	Test By	Dino
Temperature	25 °C	Humidity	65 %

No	Freq MHz	Reading dBuV	Factor dB	Level dBuV/m	Limit dBuV/m	Over Limit dB	Remark	Pol V/H
1	5850.00	47.27	-0.65	46.62	54.00	-7.38	Average	VERTICAL
2	5850.00	59.63	-0.65	58.98	74.00	-15.02	Peak	VERTICAL
1	5850.00	46.93	-0.65	46.28	54.00	-7.72	Average	HORIZONTAL
2	5850.00	60.34	-0.65	59.69	74.00	-14.31	Peak	HORIZONTAL

Remark:

- 1 Measuring frequencies from the lowest internal frequency to the 10th of fundamental frequency
- 2 Field strength limits for frequency above 1000MHz are based on average limits. However, Peak mode field strength shall not exceed the average limits specified plus 20dB.
- 3 Measurement of data within this frequency range shown “ - ” in the table above means the reading of emissions are attenuated more than 20dB below the permissible limits or the field strength is too small to be measured.
- 4 Spectrum Peak mode IF bandwidth Setting : 1GHz- 26GHz, RBW= 1MHz, Sweep time= 200 ms., the VBW setting was 3 MHz.
- 5 Spectrum AV mode if bandwidth Setting : 1GHz- 26GHz, RBW= 1MHz, VBW= 10Hz, Sweep time= 200 ms.

**Radiated Emission: 802.11AC HT80 mode, Combine**

Operation Mode	TX CH Low	Test Date	2015/04/27
Fundamental Frequency	5775 MHz	Test By	Dino
Temperature	25 °C	Humidity	65 %

No	Freq MHz	Reading dBuV	Factor dB	Level dBuV/m	Limit dBuV/m	Over Limit dB	Remark	Pol V/H
1	5150.00	52.73	-2.40	50.33	54.00	-3.67	Average	VERTICAL
2	5150.00	72.94	-2.40	70.54	74.00	-3.46	Peak	VERTICAL
1	5146.76	54.79	-2.40	52.39	74.00	-21.61	Peak	HORIZONTAL
2	5150.00	51.01	-2.40	48.61	74.00	-25.39	Peak	HORIZONTAL

Operation Mode	TX CH High	Test Date	2015/04/27
Fundamental Frequency	5775MHz	Test By	Dino
Temperature	25 °C	Humidity	65 %

No	Freq MHz	Reading dBuV	Factor dB	Level dBuV/m	Limit dBuV/m	Over Limit dB	Remark	Pol V/H
1	5850.00	49.15	-0.65	48.50	54.00	-5.50	Average	VERTICAL
2	5850.00	64.60	-0.65	63.95	74.00	-10.05	Peak	VERTICAL
3	5852.38	47.87	-0.64	47.23	54.00	-6.77	Average	VERTICAL
4	5852.38	66.83	-0.64	66.19	74.00	-7.81	Peak	VERTICAL
1	5850.00	46.87	-0.65	46.22	74.00	-27.78	Peak	HORIZONTAL

Remark:

- 1 Measuring frequencies from the lowest internal frequency to the 10th of fundamental frequency
- 2 Field strength limits for frequency above 1000MHz are based on average limits. However, Peak mode field strength shall not exceed the average limits specified plus 20dB.
- 3 Measurement of data within this frequency range shown “ - ” in the table above means the reading of emissions are attenuated more than 20dB below the permissible limits or the field strength is too small to be measured.
- 4 Spectrum Peak mode IF bandwidth Setting : 1GHz- 26GHz, RBW= 1MHz, Sweep time= 200 ms., the VBW setting was 3 MHz.
- 5 Spectrum AV mode if bandwidth Setting : 1GHz- 26GHz, RBW= 1MHz, VBW= 10Hz, Sweep time= 200 ms.

## **10. TRANSMISSION IN THE ABSENCE OF DATA**

### **10.1 Standard Applicable**

According to §15.407(c)

The device shall automatically discontinue transmission in case of either absence of information to transmit or operational failure. These provisions are not intended to preclude the transmission of control or signaling information or the use of repetitive codes used by certain digital technologies to complete frame or burst intervals. Applicants shall include in their application for equipment authorization a description of how this requirement is met.

### **10.2 Result:**

No non-compliance noted:

Refer to the theory of operation.

## 11. FREQUENCY STABILITY

### 11.1 Standard Applicable

According to §15.407 (g) Manufacturers of U-NII devices are responsible for ensuring frequency stability such that an emission is maintained within the band of operation under all conditions of normal operation as specified in the user's manual.

### 11.2 Result:

No non-compliance noted:

$\pm 20$ ppm ppm was defined in product specification.



## 12. ANTENNA REQUIREMENT

### 12.1 Standard Applicable

According to §15.203, Antenna requirement.

An intentional radiator shall be designed to ensure that no antenna other than that furnished by the responsible party shall be used with the device. The use of a permanently attached antenna or of an antenna that uses a unique coupling to the intentional radiator shall be considered sufficient to comply with the provisions of this Section. The manufacturer may design the unit so that a broken antenna can be replaced by the user, but the use of a standard antenna jack or electrical connector is prohibited. This requirement does not apply to carrier current devices or to devices operated under the provisions of Sections 15.211, 15.213, 15.217, 15.219, or 15.221. Further, this requirement does not apply to intentional radiators that must be professionally installed, such as perimeter protection systems and some field disturbance sensors, or to other intentional radiators which, in accordance with Section 15.31(d), must be measured at the installation site. However, the installer shall be responsible for ensuring that the proper antenna is employed so that the limits in this Part are not exceeded.

### 12.2 Antenna Connected Construction

The directional gains of antenna used for transmitting is below table, and the antenna connector is designed with unique type RF connector and no consideration of replacement. Please see EUT photo and antenna spec. for details.

Antenna Designation:

	<b>Manufacturer</b>	<b>Type</b>	<b>Gain (2.4GHz)</b>	<b>Gain (5GHz)</b>
Ant	Suzhou Anjie Technology Col, Ltd.	Reversed SMA type dipole Antenna	3.63dBi	6.12dBi

According to KDB662911 D01 MU-MIMO signals could be considered uncorrelated for purposes of directional gain computation.

3Tx MIMO,

Directional gain =  $G_{ANT}$  = Beamforming gain  $10\log(3) = 4.77\text{dBi}$