

FCC Radio Test Report

FCC ID : YL6VDB770X
Equipment : Video Doorbell
Brand Name : Alarm.com
Model Name : VDB770
Applicant : Alarm.com Incorporated
8281 Greensboro Drive
Suite 100 , Tysons, VA 22102 , USA
Manufacturer : Chicony Electronics Co. Ltd
36F No.69, Sec. 2, Guangfu Rd., Sanchong Dist.,
New Taipei City 24158, Taiwan, R.O.C
Standard : 47 CFR FCC Part 15.247

The product was received on Sep. 23, 2022, and testing was started from Oct. 16, 2022 and completed on Mar. 20, 2023. We, SPORTON INTERNATIONAL INC. Hsinhua Laboratory, would like to declare that the tested sample has been evaluated in accordance with the procedures given in ANSI C63.10-2013 and shown compliance with the applicable technical standards.

The test results in this report apply exclusively to the tested model / sample. Without written approval of SPORTON INTERNATIONAL INC. Hsinhua Laboratory, the test report shall not be reproduced except in full.



Approved by: Jackson Tsai

SPORTON INTERNATIONAL INC. Hsinhua Laboratory

No.52, Huaya 1st Rd., Guishan Dist., Taoyuan City 333411, Taiwan (R.O.C.)



Table of Contents

HISTORY OF THIS TEST REPORT3

SUMMARY OF TEST RESULT4

1 GENERAL DESCRIPTION5

1.1 Information.....5

1.2 Testing Applied Standards7

1.3 Testing Location Information7

1.4 Measurement Uncertainty7

2 TEST CONFIGURATION OF EUT.....8

2.1 Test Channel Mode8

2.2 The Worst Case Measurement Configuration.....8

2.3 Support Equipment.....9

2.4 Test Setup Diagram10

3 TRANSMITTER TEST RESULT11

3.1 AC Power-line Conducted Emissions11

3.2 DTS Bandwidth.....13

3.3 Maximum Conducted Output Power14

3.4 Power Spectral Density16

3.5 Emissions in Non-restricted Frequency Bands17

3.6 Emissions in Restricted Frequency Bands.....18

4 TEST EQUIPMENT AND CALIBRATION DATA.....22

APPENDIX A. TEST RESULTS OF AC POWER-LINE CONDUCTED EMISSIONS

APPENDIX B. TEST RESULTS OF DTS BANDWIDTH

APPENDIX C. TEST RESULTS OF MAXIMUM CONDUCTED OUTPUT POWER

APPENDIX D. TEST RESULTS OF POWER SPECTRAL DENSITY

APPENDIX E. TEST RESULTS OF EMISSIONS IN NON-RESTRICTED FREQUENCY BANDS

APPENDIX F. TEST RESULTS OF EMISSIONS IN RESTRICTED FREQUENCY BANDS

APPENDIX G. TEST PHOTOS

PHOTOGRAPHS OF EUT V01



History of this test report

Report No.	Version	Description	Issued Date
FR292206AL	01	Initial issue of report	Jun. 29, 2023
FR292206AL	02	Update Antenna Information (This report is the latest version replacing for the report issued on Jun. 29, 2023)	Jul. 10, 2023



Summary of Test Result

Report Clause	Ref.Std. Clause	Test Items	Result (PASS/FAIL)	Remark
1.1.2	15.203	Antenna Requirement	PASS	-
3.1	15.207	AC Power-line Conducted Emissions	PASS	-
3.2	15.247(a)	DTS Bandwidth	PASS	-
3.3	15.247(b)	Maximum Conducted Output Power	PASS	-
3.4	15.247(e)	Power Spectral Density	PASS	-
3.5	15.247(d)	Emissions in Non-restricted Frequency Bands	PASS	-
3.6	15.247(d)	Emissions in Restricted Frequency Bands	PASS	-

Declaration of Conformity:
The test results with all measurement uncertainty excluded are presented in accordance with the regulation limits or requirements declared by manufacturers.
Comments and explanations:
None

Reviewed by: Ryan Hsiao

Report Producer: Ann Hou

1 General Description

1.1 Information

1.1.1 RF General Information

Frequency Range (MHz)	Bluetooth Mode	Ch. Frequency (MHz)	Channel Number
2400-2483.5	LE	2402-2480	0-39 [40]

Band	Mode	BWch (MHz)	Nant
2.4-2.4835GHz	BT-LE(1Mbps)	1.0	1TX

Note:

- ◆ Bluetooth LE uses a GFSK (1Mbps) modulation.
- ◆ BWch is the nominal channel bandwidth.

1.1.2 Antenna Information

Ant.	Brand	Model Name	Antenna Type	Connector
1	Wieson	GY196HT337-027	Dipole	I-PEX
2	Wieson	GY196HT337-028	Dipole	I-PEX

Ant.	Port	Gain (dBi)		
		2.4G	5G	BT
1	1	0.86	1.81	0.86
2	2	1.76	1.6	-

Note 1: The EUT has two antennas.

For 2.4GHz function:

For IEEE 802.11 b/g/n/VHT/ax mode (2TX/2RX)

Ant. 1 (port 1) and Ant. 2 (port 2) could transmit/receive simultaneously.

For BT function:

For IEEE 802.15.1 Bluetooth mode (1TX/1RX)

Ant. 1 (port 1) could transmit/receive.

For 5GHz function:

For IEEE 802.11 a/n/ac/ax mode (2TX/2RX)

Ant. 1 (port 1) and Ant. 2 (port 2) could transmit/receive simultaneously.



1.1.3 EUT Information

Operational Condition	
EUT Power Type	From AC Mains
EUT Function	<input checked="" type="checkbox"/> Point-to-multipoint <input type="checkbox"/> Point-to-point
Type of EUT	
<input checked="" type="checkbox"/> Stand-alone	
<input type="checkbox"/> Combined (EUT where the radio part is fully integrated within another device)	
	Combined Equipment - Brand Name / Model No.: ...
<input type="checkbox"/> Plug-in radio (EUT intended for a variety of host systems)	
	Host System - Brand Name / Model No.: ...
<input type="checkbox"/> Other:	

1.1.4 Mode Test Duty Cycle

Mode	DC	DCF(dB)	T(s)	VBW(Hz) ≥ 1/T
BT-LE(1Mbps)	0.606	2.18	379.063u	3k

Note. If DC < 0.98, the DCF was added while measuring Output power and PSD.

1.2 Testing Applied Standards

According to the specifications of the manufacturer, the EUT must comply with the requirements of the following standards:

- ◆ 47 CFR FCC Part 15
- ◆ ANSI C63.10-2013

The following reference test guidance is not within the scope of accreditation of TAF:

- ◆ KDB 558074 D01 v05r02
- ◆ KDB 414788 D01 v01r01

1.3 Testing Location Information

Test Lab. : Sporton International Inc. Hsinhua Laboratory				
<input checked="" type="checkbox"/>	Hsinhua (TAF: 3785)	ADD: No.52, Huaya 1st Rd., Guishan Dist., Taoyuan City 333411, Taiwan (R.O.C.)		
		TEL: 886-3-327-3456	FAX: 886-3-327-0973	
Test site Designation No. TW3785 with FCC.				
Test Condition	Test Site No.	Test Engineer	Test Environment	Test Date
AC Conduction	CO04-HY	Edward Wang	20.3~21.2°C / 51~53%	10/Feb/2023
RF Conducted	TH07-HY	Yuna Lin	22.5~23.2°C / 52~55%	18/Oct/2022
Radiated	03CH03-HY	Daniel Lin	21.4~25.9°C / 53~61%	16/Oct/2022~20/Mar/2023
<input type="checkbox"/>	Wen 33rd.St. (TAF: 3785)	ADD: No.14-1, Ln. 19, Wen 33rd St., Guishan Dist., Taoyuan City 333010, Taiwan (R.O.C.)		
		TEL: 886-3-318-0787	FAX: 886-3-318-0287	
Test site Designation No. TW0008 with FCC.				

1.4 Measurement Uncertainty

ISO/IEC 17025 requires that an estimate of the measurement uncertainties associated with the emissions test results be included in the report. The measurement uncertainties given below are based on a 95% confidence level (based on a coverage factor (k=2))

Test Items	Uncertainty	Remark
AC Power-line Conducted Emissions	4.53 dB	Confidence levels of 95%
Bandwidth	3 MHz	Confidence levels of 95%
Maximum Conducted Output Power	2 dB	Confidence levels of 95%
Power Spectral Density	2 dB	Confidence levels of 95%
Emissions in Non-restricted Frequency Bands	0.14 dB	Confidence levels of 95%
Emissions in Restricted Frequency Bands	4.8 dB	Confidence levels of 95%
Temperature	0.41 °C	Confidence levels of 95%
Humidity	3.4 %	Confidence levels of 95%

2 Test Configuration of EUT



2.1 Test Channel Mode

Test Software Version	Tera term4.76
Mode	Power Setting
BT-LE(1Mbps)	-
2402MHz	Default
2440MHz	Default
2480MHz	Default

2.2 The Worst Case Measurement Configuration

The Worst Case Mode for Following Conformance Tests	
Tests Item	AC power-line conducted emissions
Condition	AC power-line conducted measurement for line and neutral Test Voltage: 120Vac / 60Hz
Operating Mode	CTX
1	Transformer mode

The Worst Case Mode for Following Conformance Tests	
Tests Item	DTS Bandwidth Maximum Conducted Output Power Power Spectral Density Emissions in Non-restricted Frequency Bands
Test Condition	Conducted measurement at transmit chains

The Worst Case Mode for Following Conformance Tests			
Tests Item	Emissions in Restricted Frequency Bands		
Test Condition	Radiated measurement If EUT consist of multiple antenna assembly (multiple antenna are used in EUT regardless of spatial multiplexing MIMO configuration), the radiated test should be performed with highest antenna gain of each antenna type.		
Operating Mode < 1GHz	CTX		
1	Transformer mode		
Operating Mode > 1GHz	CTX		
Orthogonal Planes of EUT	X Plane	Y Plane	Z Plane
			
Worst Planes of EUT	V		



2.3 Support Equipment

Support Equipment – AC Conduction					
No.	Equipment	Brand Name	Model Name	FCC ID	Remark
1	AC Power Cable	Power sync	PW-GPC180-3	-	-
2	DC Power cable	NA	NA	-	Provided by Customer
3	Transformer	NA	NA	-	Provided by Customer
4	Core	King Core	KCF-50-B	-	-

Support Equipment – Conducted					
No.	Equipment	Brand Name	Model Name	FCC ID	Remark
1	Notebook	DELL	E5410	-	-
2	Adapter for NB	DELL	HA65NM130	-	-

Support Equipment – Radiated					
No.	Equipment	Brand Name	Model Name	FCC ID	Remark
1	AC Power Cable	Power sync	PW-GPC180-3	-	-
2	DC Power cable	NA	NA	-	Provided by Customer
3	Transformer	NA	NA	-	Provided by Customer
4	Core	King Core	KCF-50-B	-	-

2.4 Test Setup Diagram

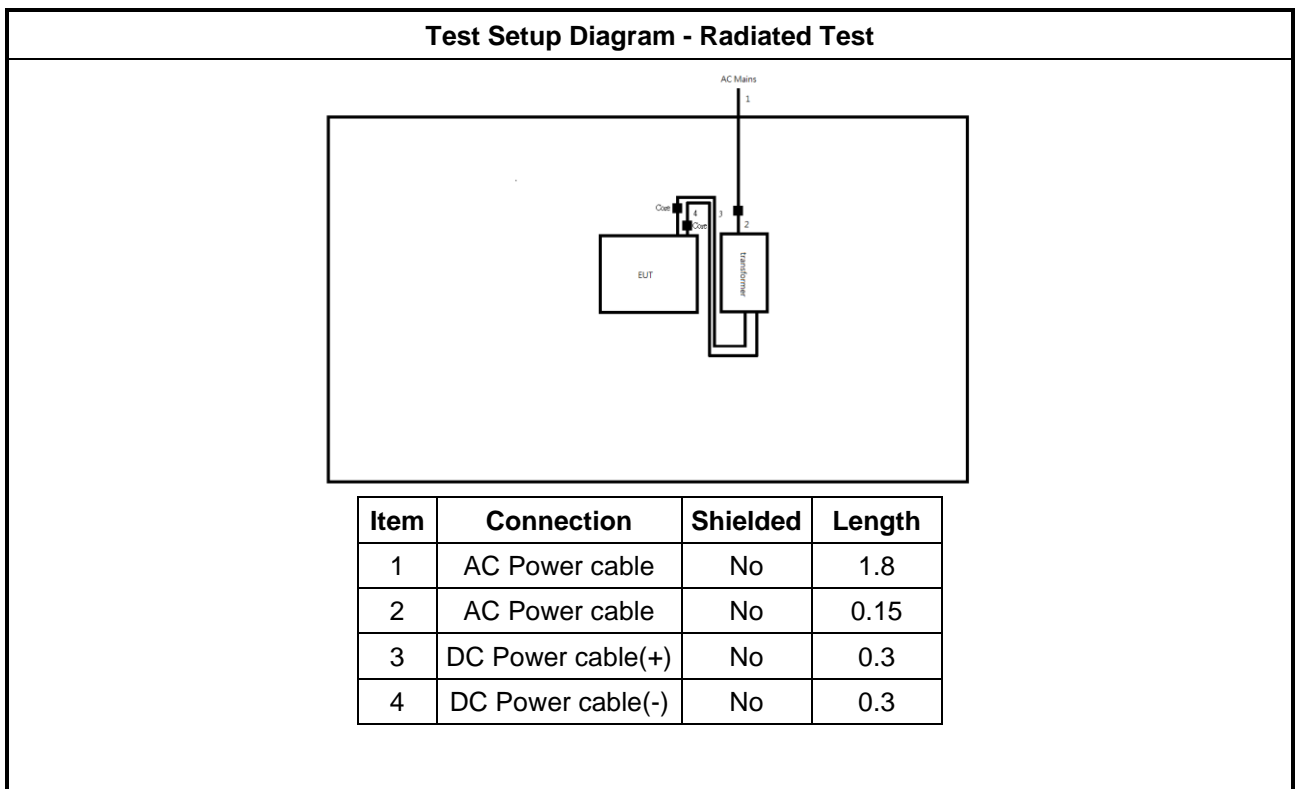
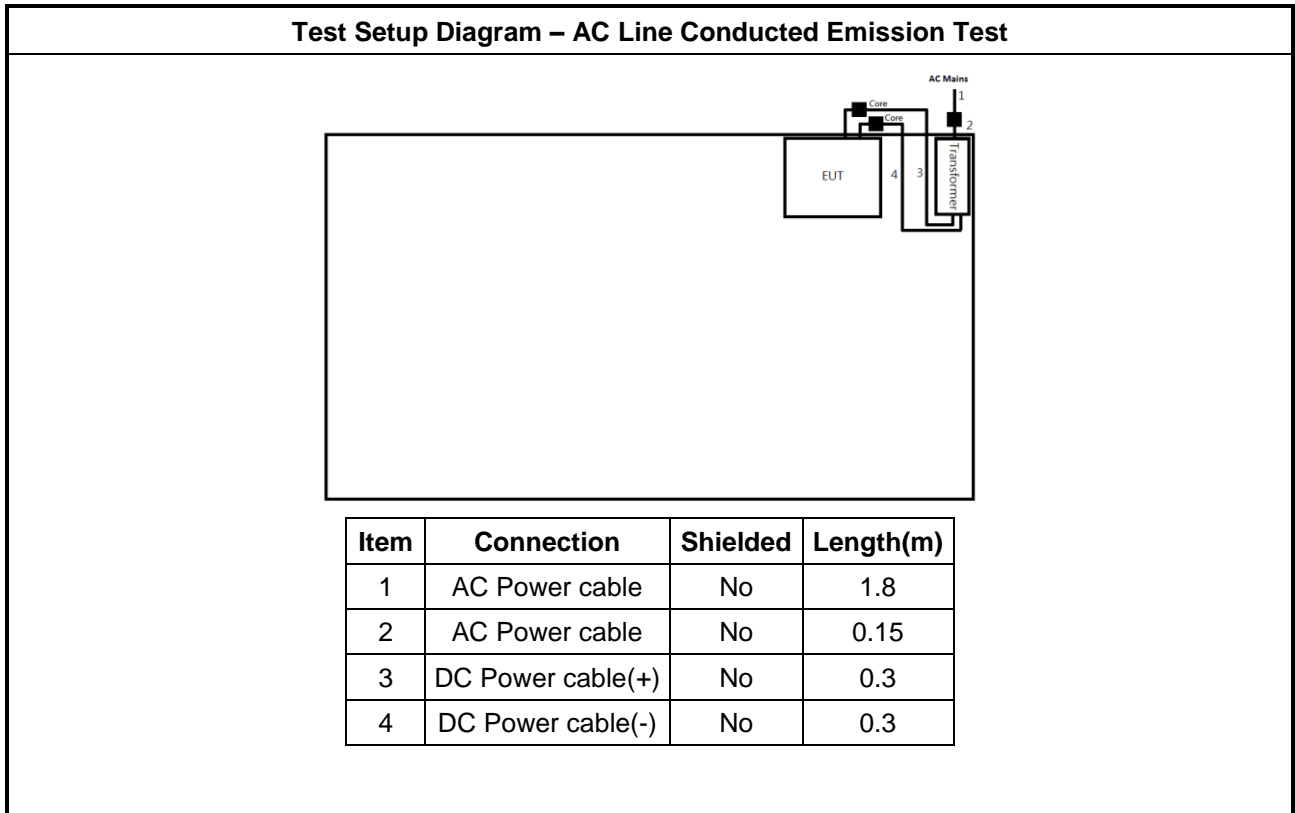

3 Transmitter Test Result

3.1 AC Power-line Conducted Emissions

3.1.1 AC Power-line Conducted Emissions Limit

AC Power-line Conducted Emissions Limit		
Frequency Emission (MHz)	Quasi-Peak	Average
0.15-0.5	66 - 56 *	56 - 46 *
0.5-5	56	46
5-30	60	50

Note 1: * Decreases with the logarithm of the frequency.

3.1.2 Measuring Instruments

Refer a test equipment and calibration data table in this test report.

3.1.3 Test Procedures

Test Method
<ul style="list-style-type: none"> Refer as ANSI C63.10-2013, clause 6.2 foray power-line conducted emissions.

3.1.4 Measurement Results Calculation

The measured Level is calculated using:

Corrected Reading: Raw(Read Level) + LISN(LISN Factor) + CL(Cable Loss) + AT(Attenuator).

3.1.5 Test Setup

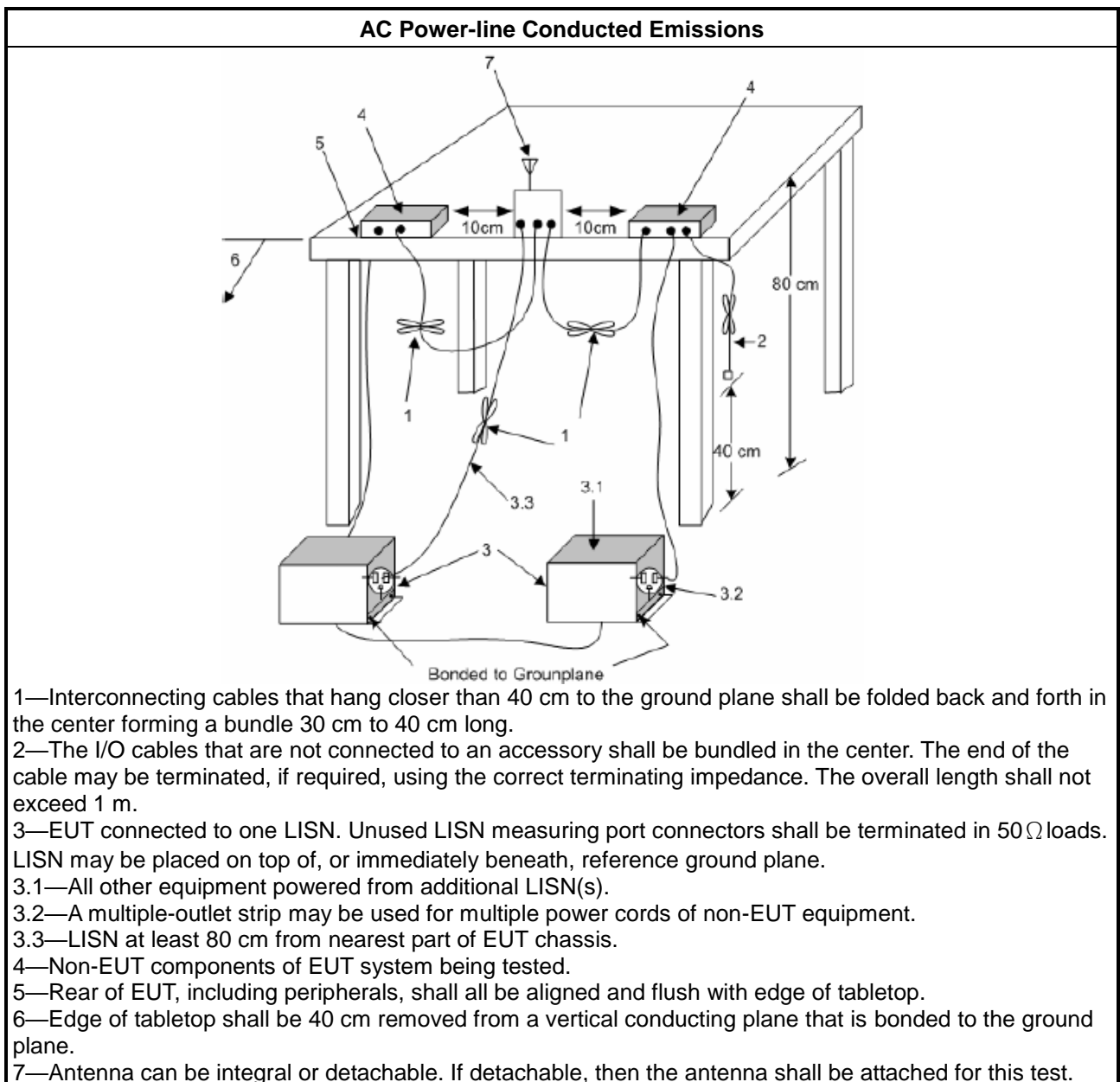

3.1.6 Test Result of AC Power-line Conducted Emissions

Refer as Appendix A

3.2 DTS Bandwidth

3.2.1 6dB Bandwidth Limit

6dB Bandwidth Limit
Systems using digital modulation techniques:
<ul style="list-style-type: none"> ▪ 6 dB bandwidth \geq 500 kHz.

3.2.2 Measuring Instruments

Refer a test equipment and calibration data table in this test report.

3.2.3 Test Procedures

Test Method
<ul style="list-style-type: none"> ▪ For the emission bandwidth shall be measured using one of the options below:
<input checked="" type="checkbox"/> Refer as KDB 558074, clause 8.2 (11.8 of ANSI C63.10) DTS bandwidth measurement.
<input type="checkbox"/> Refer as RSS-Gen, clause 6.7 for occupied bandwidth testing.
<input type="checkbox"/> Refer as ANSI C63.10, clause 6.9.3 for occupied bandwidth testing.

3.2.4 Test Setup

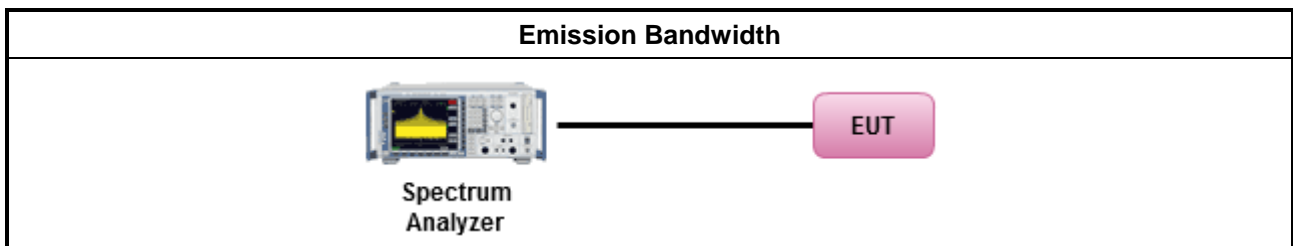

3.2.5 Test Result of Emission Bandwidth

Refer as Appendix B

3.3 Maximum Conducted Output Power

3.3.1 Maximum Conducted Output Power Limit

Maximum Conducted Output Power Limit	
	<ul style="list-style-type: none"> ▪ If $G_{TX} \leq 6$ dBi, then $P_{Out} \leq 30$ dBm (1 W)
	<ul style="list-style-type: none"> ▪ Point-to-multipoint systems (P2M): If $G_{TX} > 6$ dBi, then $P_{Out} = 30 - (G_{TX} - 6)$ dBm
	<ul style="list-style-type: none"> ▪ Point-to-point systems (P2P): If $G_{TX} > 6$ dBi, then $P_{Out} = 30 - (G_{TX} - 6)/3$ dBm
	<ul style="list-style-type: none"> ▪ Smart antenna system (SAS):
	<ul style="list-style-type: none"> - Single beam: If $G_{TX} > 6$ dBi, then $P_{Out} = 30 - (G_{TX} - 6)/3$ dBm
	<ul style="list-style-type: none"> - Overlap beam: If $G_{TX} > 6$ dBi, then $P_{Out} = 30 - (G_{TX} - 6)/3$ dBm
	<ul style="list-style-type: none"> - Aggregate power on all beams: If $G_{TX} > 6$ dBi, then $P_{Out} = 30 - (G_{TX} - 6)/3 + 8$ dB dBm
e.i.r.p. Power Limit:	
	<ul style="list-style-type: none"> ▪ 2400-2483.5 MHz Band
	<ul style="list-style-type: none"> ▪ Point-to-multipoint systems (P2M): $P_{eirp} \leq 36$ dBm (4 W)
	<ul style="list-style-type: none"> ▪ Point-to-point systems (P2P): $P_{eirp} \leq \text{MAX}(36, [P_{Out} + G_{TX}])$ dBm
	<ul style="list-style-type: none"> ▪ Smart antenna system (SAS)
	<ul style="list-style-type: none"> - Single beam: $P_{eirp} \leq \text{MAX}(36, P_{Out} + G_{TX})$ dBm
	<ul style="list-style-type: none"> - Overlap beam: $P_{eirp} \leq \text{MAX}(36, P_{Out} + G_{TX})$ dBm
	<ul style="list-style-type: none"> - Aggregate power on all beams: $P_{eirp} \leq \text{MAX}(36, [P_{Out} + G_{TX} + 8])$ dBm
P_{Out} = maximum peak conducted output power or maximum conducted output power in dBm, G_{TX} = the maximum transmitting antenna directional gain in dBi.	

3.3.2 Measuring Instruments

Refer a test equipment and calibration data table in this test report.

3.3.3 Test Procedures

Test Method	
<ul style="list-style-type: none"> ▪ Maximum Peak Conducted Output Power 	
<input type="checkbox"/>	Refer as KDB 558074, clause 8.3.1.1 (11.9.1.1 of ANSI C63.10) RBW ≥ EBW method.
<input type="checkbox"/>	Refer as KDB 558074, clause 8.3.1.2 (11.9.1.2 of ANSI C63.10) integrated band power method.
<input type="checkbox"/>	Refer as KDB 558074, clause 8.3.1.3 (11.9.1.3 of ANSI C63.10) peak power meter.
<ul style="list-style-type: none"> ▪ Maximum Average Conducted Output Power 	
<input type="checkbox"/>	Refer as KDB 558074, clause 8.3.2.2 (11.9.2.2 of ANSI C63.10) using a spectrum analyzer.
<input checked="" type="checkbox"/>	Refer as KDB 558074, clause 8.3.2.3 (11.9.2.3 of ANSI C63.10) using a power meter.
<ul style="list-style-type: none"> ▪ For conducted measurement. 	
<ul style="list-style-type: none"> ▪ If the EUT supports multiple transmit chains using options given below: Refer as KDB 662911, In-band power measurements. Using the measure-and-sum approach, measured all transmit ports individually. Sum the power (in linear power units e.g., mW) of all ports for each individual sample and save them. 	
<ul style="list-style-type: none"> ▪ If multiple transmit chains, EIRP calculation could be following as methods: $P_{total} = P_1 + P_2 + \dots + P_n$ (calculated in linear unit [mW] and transfer to log unit [dBm]) $EIRP_{total} = P_{total} + DG$ 	

3.3.4 Test Setup

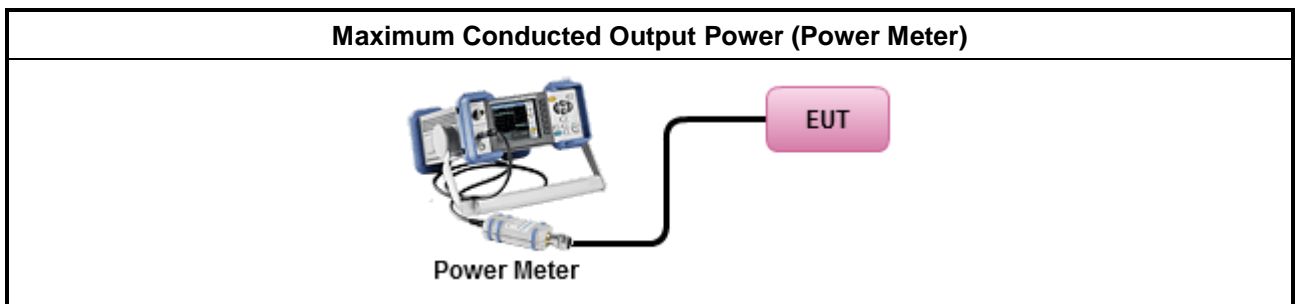

3.3.5 Test Result of Maximum Conducted Output Power

Refer as Appendix C

3.4 Power Spectral Density

3.4.1 Power Spectral Density Limit

Power Spectral Density Limit
<ul style="list-style-type: none"> Power Spectral Density (PSD) ≤ 8 dBm/3kHz

3.4.2 Measuring Instruments

Refer a test equipment and calibration data table in this test report.

3.4.3 Test Procedures

Test Method	
<ul style="list-style-type: none"> Peak power spectral density procedures that the same method as used to determine the conducted output power. If maximum peak conducted output power was measured to demonstrate compliance to the output power limit, then the peak PSD procedure below (Method PKPSD) shall be used. If maximum conducted output power was measured to demonstrate compliance to the output power limit, then one of the average PSD procedures shall be used, as applicable based on the following criteria (the peak PSD procedure is also an acceptable option). 	
<input checked="" type="checkbox"/> Refer as KDB 558074, clause 8.4 (11.10 of ANSI C63.10) Max. PSD.	
<ul style="list-style-type: none"> For conducted measurement. <ul style="list-style-type: none"> If The EUT supports multiple transmit chains using options given below: <ul style="list-style-type: none"> Measure and sum the spectra across the outputs. Refer as KDB 662911, In-band power spectral density (PSD). Sample all transmit ports simultaneously using a spectrum analyzer for each transmit port. Where the trace bin-by-bin of each transmit port summing can be performed. (i.e., in the first spectral bin of output 1 is summed with that in the first spectral bin of output 2 and that from the first spectral bin of output 3, and so on up to the NTX output to obtain the value for the first frequency bin of the summed spectrum.). Add up the amplitude (power) values for the different transmit chains and use this as the new data trace. 	

3.4.4 Test Setup

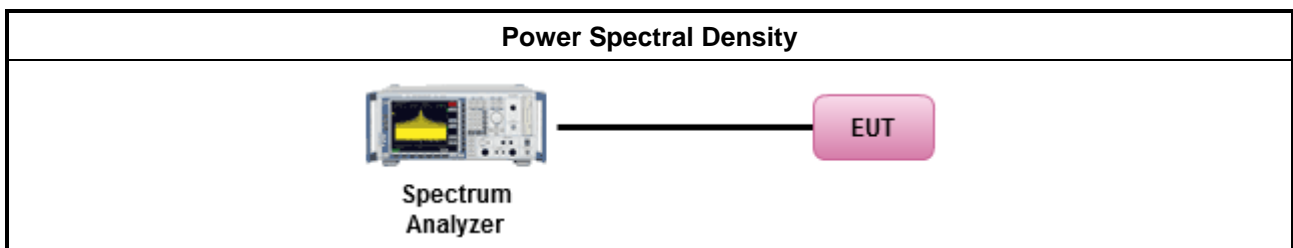

3.4.5 Test Result of Power Spectral Density

Refer as Appendix D

3.5 Emissions in Non-restricted Frequency Bands

3.5.1 Emissions in Non-restricted Frequency Bands Limit

Un-restricted Band Emissions Limit	
RF output power procedure	Limit (dB)
Peak output power procedure	20
Average output power procedure	30

Note 1: If the peak output power procedure is used to measure the fundamental emission power to demonstrate compliance to requirements, then the peak conducted output power measured within any 100 kHz outside the authorized frequency band shall be attenuated by at least 20 dB relative to the maximum measured in-band peak level.

Note 2: If the average output power procedure is used to measure the fundamental emission power to demonstrate compliance to requirements, then the power in any 100 kHz outside of the authorized frequency band shall be attenuated by at least 30 dB relative to the maximum measured in-band average level.

3.5.2 Measuring Instruments

Refer a test equipment and calibration data table in this test report.

3.5.3 Test Procedures

Test Method
<ul style="list-style-type: none"> Refer as KDB 558074, clause 8.5 (11.11 of ANSI C63.10) for non-restricted frequency bands.

3.5.4 Test Setup

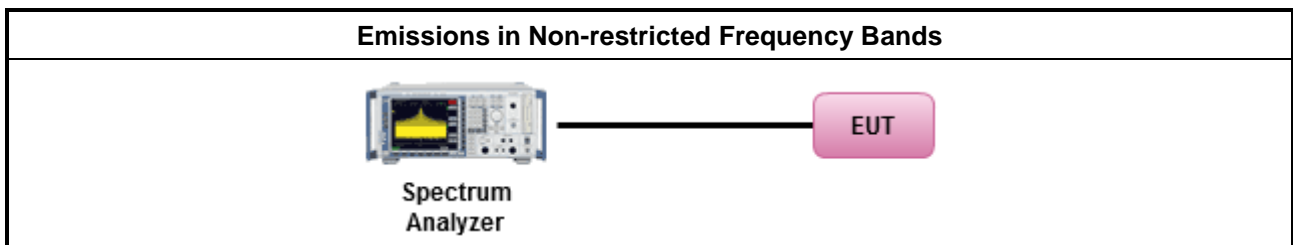

3.5.5 Test Result of Emissions in Non-restricted Frequency Bands

Refer as Appendix E

3.6 Emissions in Restricted Frequency Bands

3.6.1 Emissions in Restricted Frequency Bands Limit

Restricted Band Emissions Limit			
Frequency Range (MHz)	Field Strength (uV/m)	Field Strength (dBuV/m)	Measure Distance (m)
0.009~0.490	2400/F(kHz)	48.5 - 13.8	300
0.490~1.705	24000/F(kHz)	33.8 - 23	30
1.705~30.0	30	29	30
30~88	100	40	3
88~216	150	43.5	3
216~960	200	46	3
Above 960	500	54	3

Note 1: Test distance for frequencies at or above 30 MHz, measurements may be performed at a distance other than the limit distance provided they are not performed in the near field and the emissions to be measured can be detected by the measurement equipment. When performing measurements at a distance other than that specified, the results shall be extrapolated to the specified distance using an extrapolation factor of 20 dB/decade (inverse of linear distance for field-strength measurements, inverse of linear distance-squared for power-density measurements).

Note 2: Test distance for frequencies at below 30 MHz, measurements may be performed at a distance closer than the EUT limit distance; however, an attempt should be made to avoid making measurements in the near field. When performing measurements below 30 MHz at a closer distance than the limit distance, the results shall be extrapolated to the specified distance by either making measurements at a minimum of two or more distances on at least one radial to determine the proper extrapolation factor or by using the square of an inverse linear distance extrapolation factor (40 dB / decade). The test report shall specify the extrapolation method used to determine compliance of the EUT.

Note 3: Using the distance of 1m during the test for above 18 GHz, and the test value to correct for the distance factor at 3m.

3.6.2 Measuring Instruments

Refer a test equipment and calibration data table in this test report.

3.6.3 Test Procedures

Test Method	
	<ul style="list-style-type: none"> ▪ The average emission levels shall be measured in [duty cycle \geq 98 or duty factor].
	<ul style="list-style-type: none"> ▪ Refer as ANSI C63.10, clause 6.10.3 band-edge testing shall be performed at the lowest frequency channel and highest frequency channel within the allowed operating band.
	<ul style="list-style-type: none"> ▪ For the transmitter unwanted emissions shall be measured using following options below:
	<ul style="list-style-type: none"> ▪ Refer as KDB 558074, clause 8.6 (11.12 of ANSI C63.10) for restricted frequency bands.
	<ul style="list-style-type: none"> ▪ For the transmitter band-edge emissions shall be measured using following options below:
	<ul style="list-style-type: none"> ▪ Refer as KDB 558074 clause 8.7.1, When the performing peak or average radiated measurements, emissions within 2 MHz of the authorized band edge may be measured using the marker-delta method described below.
	<ul style="list-style-type: none"> ▪ Refer as KDB 558074, clause 8.7.2 (6.10.6 of ANSI C63.10) for marker-delta method for band-edge measurements.
	<ul style="list-style-type: none"> ▪ Refer as KDB 558074, clause 8.7.3 for narrower resolution bandwidth (100kHz) using the band power and summing the spectral levels.
	<ul style="list-style-type: none"> ▪ Use the following spectrum analyzer settings:
	<ul style="list-style-type: none"> ▪ Set RBW=100 kHz for $f < 1$ GHz; VBW=3 * RBW; Sweep = auto; Detector function = peak; Trace = max hold.
	<ul style="list-style-type: none"> ▪ Set RBW = 1 MHz, VBW= 3MHz for $f \geq 1$ GHz for peak measurement. For average measurement, refer as 1.1.4.
	<ul style="list-style-type: none"> ▪ KDB 414788 Open-Field Test Sites and Chamber Correlation Justification.
	<ul style="list-style-type: none"> ▪ Based on FCC 15.31(f)(2): measurements may be performed at a distance closer than that specified in regulations; however, an attempt should be made to avoid making measurements in the near field.
	<ul style="list-style-type: none"> ▪ Open-field site and chamber correlation testing had been performed and chamber measured test result is the worst case test result.

3.6.4 Measurement Results Calculation

The measured Level is calculated using:

Corrected Reading: Raw(Read Level) + AF(Antenna Factor) + CL(Cable Loss) - PA(Preamp Factor)

3.6.5 Test Setup

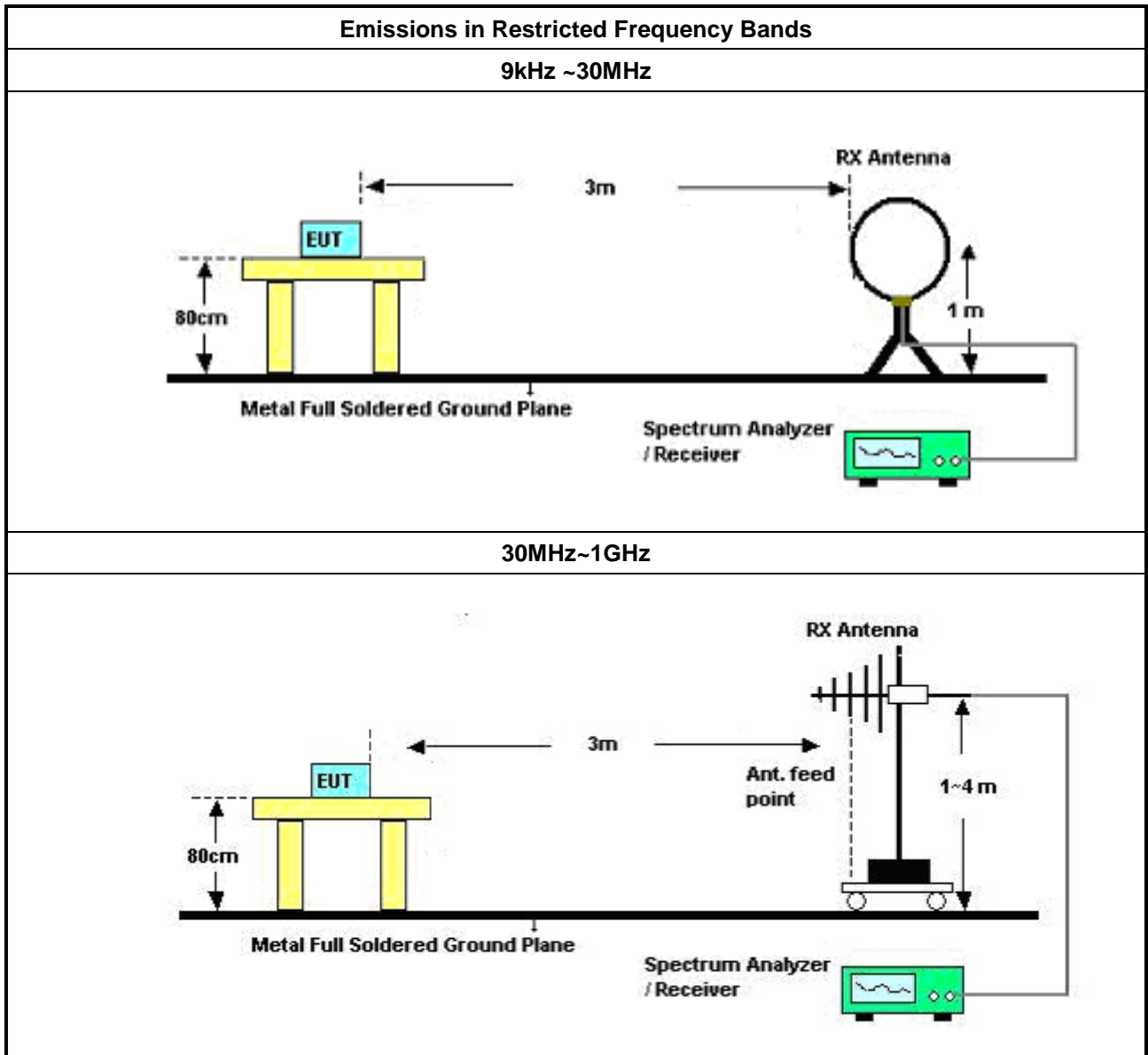

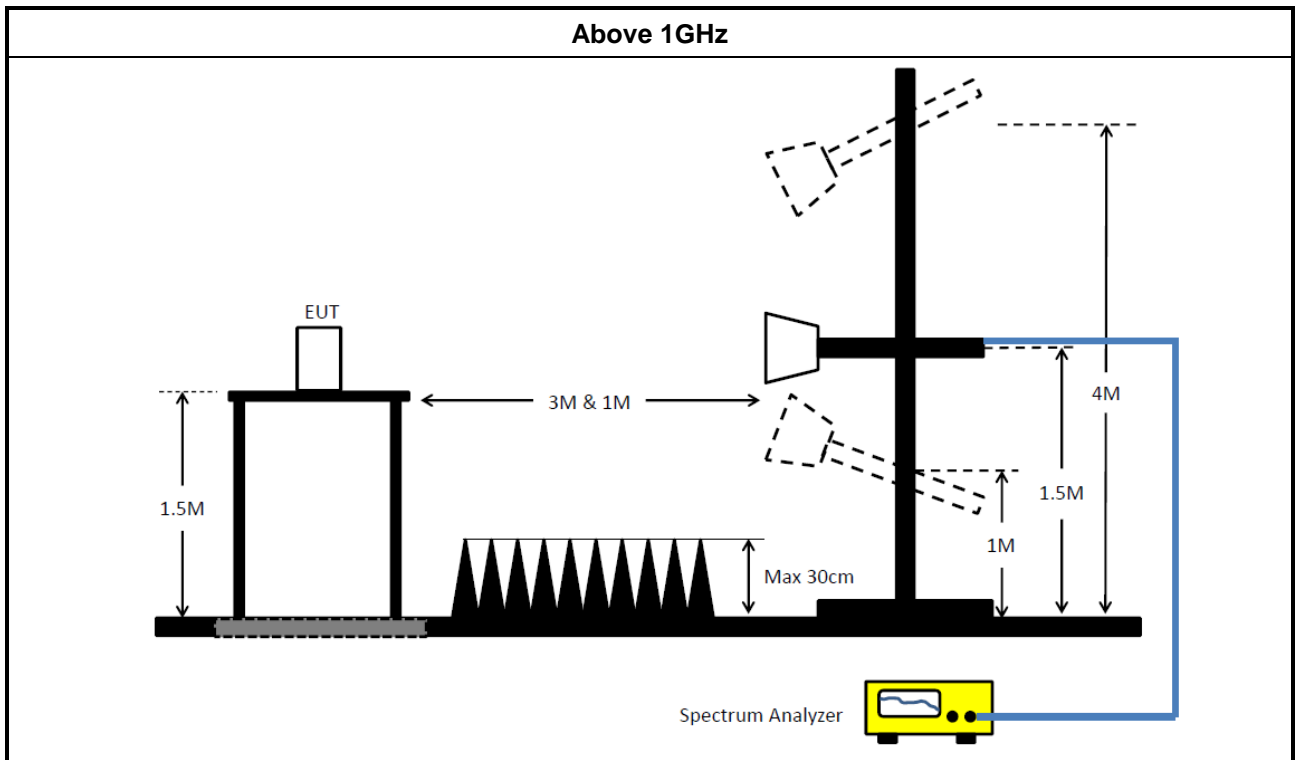

3.6.6 Test Result of Emissions in Restricted Frequency Bands (Below 30MHz)

The amplitude of spurious emissions which are attenuated by more than 20dB below the permissible value has no need to be reported.

3.6.7 Test Result of Emissions in Restricted Frequency Bands

Refer as Appendix F

4 Test Equipment and Calibration Data

Instrument for AC Conduction

Instrument	Manufacturer /Brand	Model No.	Serial No.	Spec.	Calibration Date	Calibration Due Date
EMI Test Receiver	R&S	ESR	102051	9kHz ~ 3.6GHz	13/May/2022	12/May/2023
Two-Line V-Network	R&S	ENV 216	101295	9kHz ~ 30MHz	31/Jan/2023	30/Jan/2024
RF Cable 5m	TITAN	TITAN	CO04-cable-01	9 kHz~200MHz	01/Mar/2022	28/Feb/2023
Impuls Begrenzer Pulse Limiter	SCHWARZBECK	VTSD 9561-F	9561-F041	9kHz ~ 30MHz	25/Oct/2022	24/Oct/2023
Software	Sporton	SENSE-EMI	V5.10.8.7	-	NCR	NCR

NCR: No Calibration Required

Instrument for Conducted Test

Instrument	Manufacturer /Brand	Model No.	Serial No.	Spec.	Calibration Date	Calibration Due Date
Signal Analyzer	R&S	FSV 40	101515	10Hz~40GHz	14/Feb/2022	13/Feb/2023
SMB100A Signal Generator	R&S	SMB100A	181147	100kHz~40GHz	21/Oct/2021	20/Oct/2022
Pulse Sensor	Anritsu	MA2411B	1339407	300MHz~40GHz	17/Dec/2021	16/Dec/2022
Power Meter	Anritsu	ML2495A	1517010	300MHz~40GHz	20/Dec/2021	19/Dec/2022
SENSE-15247_FS	Sporton	V5.10.7.16	N/A	N/A	N/A	N/A

Instrument for Radiated Test

Instrument	Manufacturer /Brand	Model No.	Serial No.	Spec.	Calibration Date	Calibration Due Date
3m Semi Anechoic Chamber	SIDT FRANKONIA	SAC-3M	03CH03-HY	30MHz~1GHz 3m	01/Aug/2022	31/Jul/2023
3m Semi Anechoic Chamber	SIDT FRANKONIA	SAC-3M	03CH03-HY	1GHz~18GHz 3m	02/Aug/2022	01/Aug/2023
Signal Analyzer	R&S	FSV40	101500	10Hz~40GHz	26/Oct/2022	25/Oct/2023
Amplifier	HP	8447D	2944A08033	10kHz~1.3GHz	08/Apr/2022	07/Apr/2023
Double Ridged Guide Horn Antenna	SCHWARZBECK	BBHA 9120 D	02267	1GHz ~18GHz	27/Sep/2022	26/Sep/2023
Bilog Antenna & 6dB Attenuator	SCHAFFNER / EMCI	CBL6112B / N-6-05	22237 / AT-N-0603	30MHz~1GHz	16/Oct/2022	15/Oct/2023
RF Cable-R03m	Jye Bao	RG142	CB021	9kHz~30MHz	13/Jun/2022	12/Jun/2023
RF Cable-R03m	Jye Bao	RG142	MY37335/4+CB021-1+CB021-2	30MHz~1GHz	22/Mar/2022	21/Mar/2023
RF CABLE 5+6m	HUBER+SUHNER	SUOFLEX 104	03CH03-cable-01	1GHz~40GHz	27/Jul/2022	26/Jul/2023
Broadband Horn Antenna	SCHWARZBECK	BBHA 9170	BBHA 9170154	18 GHz ~ 40 GHz	14/May/2022	13/May/2023
Microwave Prempplier	Agilent	8449B	3008A02326	1GHz~26.5GHz	14/Jul/2022	13/Jul/2023
Amplifier	EM	EM18G40GA	060874	18GHz ~40GHz	23/Aug/2022	22/Aug/2023
Loop Antenna	ROHDE & SCHWARZ	HLA 6120HFH2-Z2	100330	9kHz~30MHz	01/Nov/2022	31/Oct/2023
EMI Test Receiver	R&S	ESR3	102052	9kHz~3.6GHz	30/May/2022	29/May/2023
SENSE-15247_FS	Sporton	V5.11.1	NA	NA	NA	NA



Summary

Mode	Result	Type	Freq (Hz)	Level (dBuV)	Limit (dBuV)	Margin (dB)	Condition
Mode 1	Pass	AV	601.76k	35.97	46.00	-10.03	Line



Mode Configure

Mode	Result	Type	Freq (Hz)	Level (dBuV)	Limit (dBuV)	Margin (dB)	Condition	Comments
Mode 1	Pass	QP	301.641k	34.39	60.21	-25.82	Line	-
Mode 1	Pass	AV	301.641k	26.49	50.21	-23.72	Line	-
Mode 1	Pass	QP	601.76k	44.40	56.00	-11.60	Line	-
Mode 1	Pass	AV	601.76k	35.97	46.00	-10.03	Line	-
Mode 1	Pass	QP	904.195k	40.63	56.00	-15.37	Line	-
Mode 1	Pass	AV	904.195k	29.21	46.00	-16.79	Line	-
Mode 1	Pass	QP	3.117M	22.60	56.00	-33.40	Line	-
Mode 1	Pass	AV	3.117M	18.64	46.00	-27.36	Line	-
Mode 1	Pass	QP	6.218M	16.05	60.00	-43.95	Line	-
Mode 1	Pass	AV	6.218M	14.71	50.00	-35.29	Line	-
Mode 1	Pass	QP	10.873M	16.42	60.00	-43.58	Line	-
Mode 1	Pass	AV	10.873M	14.97	50.00	-35.03	Line	-
Mode 1	Pass	QP	301.641k	32.72	60.21	-27.49	Neutral	-
Mode 1	Pass	AV	301.641k	22.25	50.21	-27.96	Neutral	-
Mode 1	Pass	QP	604.167k	43.54	56.00	-12.46	Neutral	-
Mode 1	Pass	AV	604.167k	35.20	46.00	-10.80	Neutral	-
Mode 1	Pass	QP	904.195k	39.60	56.00	-16.40	Neutral	-
Mode 1	Pass	AV	904.195k	29.86	46.00	-16.14	Neutral	-
Mode 1	Pass	QP	2.81M	23.32	56.00	-32.68	Neutral	-
Mode 1	Pass	AV	2.81M	19.27	46.00	-26.73	Neutral	-
Mode 1	Pass	QP	7.745M	15.79	60.00	-44.21	Neutral	-
Mode 1	Pass	AV	7.745M	14.71	50.00	-35.29	Neutral	-
Mode 1	Pass	QP	11.362M	15.99	60.00	-44.01	Neutral	-
Mode 1	Pass	AV	11.362M	14.62	50.00	-35.38	Neutral	-

Conducted Emissions at Powerline_Mode 1

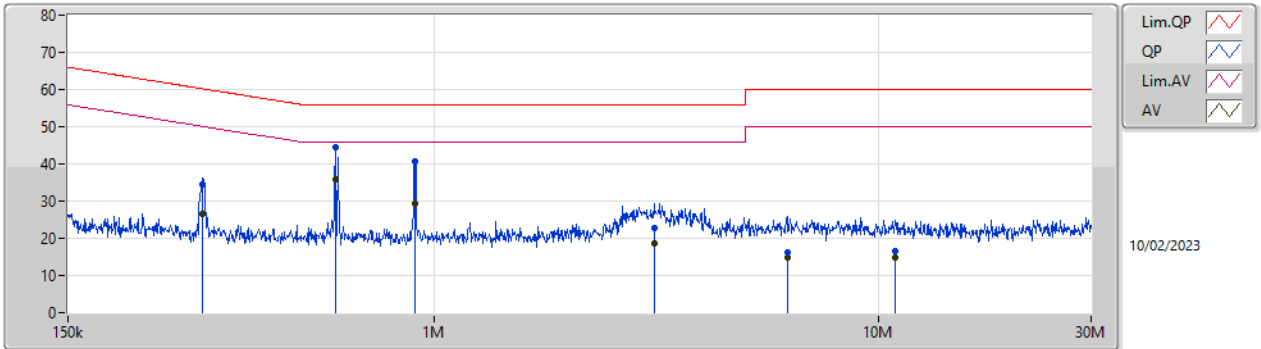

Type	Freq (Hz)	Level (dBuV)	Limit (dBuV)	Margin (dB)	Factor (dB)	Condition	Comment	Raw (dBuV)	LISN (dB)	CL (dB)	AT (dB)
QP	301.641k	34.39	60.21	-25.82	19.59	Line	-	14.80	9.60	0.04	9.95
AV	301.641k	26.49	50.21	-23.72	19.59	Line	-	6.90	9.60	0.04	9.95
QP	601.76k	44.40	56.00	-11.60	19.59	Line	-	24.81	9.60	0.04	9.95
AV	601.76k	35.97	46.00	-10.03	19.59	Line	-	16.38	9.60	0.04	9.95
QP	904.195k	40.63	56.00	-15.37	19.60	Line	-	21.03	9.61	0.05	9.94
AV	904.195k	29.21	46.00	-16.79	19.60	Line	-	9.61	9.61	0.05	9.94
QP	3.117M	22.60	56.00	-33.40	19.70	Line	-	2.90	9.66	0.11	9.93
AV	3.117M	18.64	46.00	-27.36	19.70	Line	-	-1.06	9.66	0.11	9.93
QP	6.218M	16.05	60.00	-43.95	19.79	Line	-	-3.74	9.70	0.15	9.94
AV	6.218M	14.71	50.00	-35.29	19.79	Line	-	-5.08	9.70	0.15	9.94
QP	10.873M	16.42	60.00	-43.58	19.87	Line	-	-3.45	9.72	0.19	9.96
AV	10.873M	14.97	50.00	-35.03	19.87	Line	-	-4.90	9.72	0.19	9.96

Conducted Emissions at Powerline_Mode 1

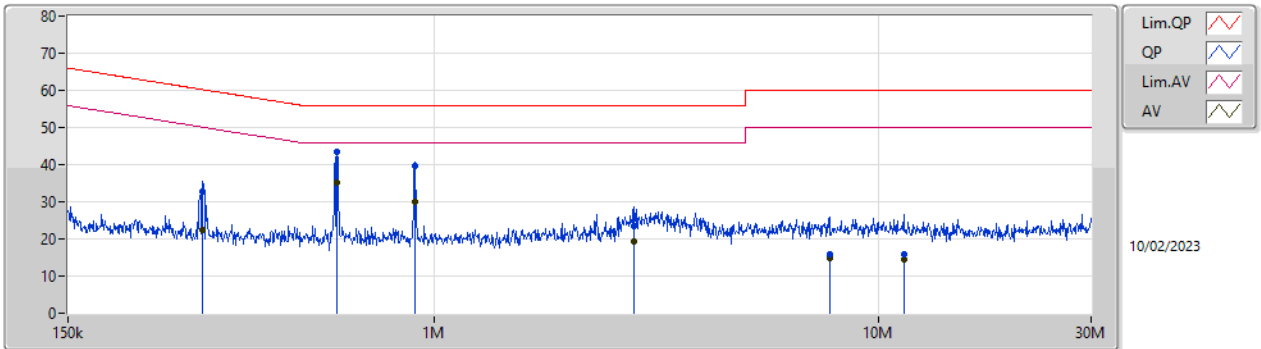

Type	Freq (Hz)	Level (dBuV)	Limit (dBuV)	Margin (dB)	Factor (dB)	Condition	Comment	Raw (dBuV)	LISN (dB)	CL (dB)	AT (dB)
QP	301.641k	32.72	60.21	-27.49	19.59	Neutral	-	13.13	9.60	0.04	9.95
AV	301.641k	22.25	50.21	-27.96	19.59	Neutral	-	2.66	9.60	0.04	9.95
QP	604.167k	43.54	56.00	-12.46	19.59	Neutral	-	23.95	9.60	0.04	9.95
AV	604.167k	35.20	46.00	-10.80	19.59	Neutral	-	15.61	9.60	0.04	9.95
QP	904.195k	39.60	56.00	-16.40	19.60	Neutral	-	20.00	9.61	0.05	9.94
AV	904.195k	29.86	46.00	-16.14	19.60	Neutral	-	10.26	9.61	0.05	9.94
QP	2.81M	23.32	56.00	-32.68	19.67	Neutral	-	3.65	9.63	0.10	9.94
AV	2.81M	19.27	46.00	-26.73	19.67	Neutral	-	-0.40	9.63	0.10	9.94
QP	7.745M	15.79	60.00	-44.21	19.80	Neutral	-	-4.01	9.68	0.17	9.95
AV	7.745M	14.71	50.00	-35.29	19.80	Neutral	-	-5.09	9.68	0.17	9.95
QP	11.362M	15.99	60.00	-44.01	19.86	Neutral	-	-3.87	9.70	0.20	9.96
AV	11.362M	14.62	50.00	-35.38	19.86	Neutral	-	-5.24	9.70	0.20	9.96



Summary

Mode	Max-N dB (Hz)	Max-OBW (Hz)	ITU-Code	Min-N dB (Hz)	Min-OBW (Hz)
2.4-2.4835GHz	-	-	-	-	-
BT-LE(1Mbps)	677.5k	1.048M	1M05F1D	676.25k	1.043M

Max-N dB = Maximum 6dB down bandwidth; Max-OBW = Maximum 99% occupied bandwidth;
Min-N dB = Minimum 6dB down bandwidth; Min-OBW = Minimum 99% occupied bandwidth



Result

Mode	Result	Limit (Hz)	Port 1-N dB (Hz)	Port 1-OBW (Hz)
BT-LE(1Mbps)	-	-	-	-
2402MHz	Pass	500k	677.5k	1.048M
2440MHz	Pass	500k	677.5k	1.043M
2480MHz	Pass	500k	676.25k	1.043M

Port X-N dB = Port X 6dB down bandwidth;
Port X-OBW = Port X 99% occupied bandwidth

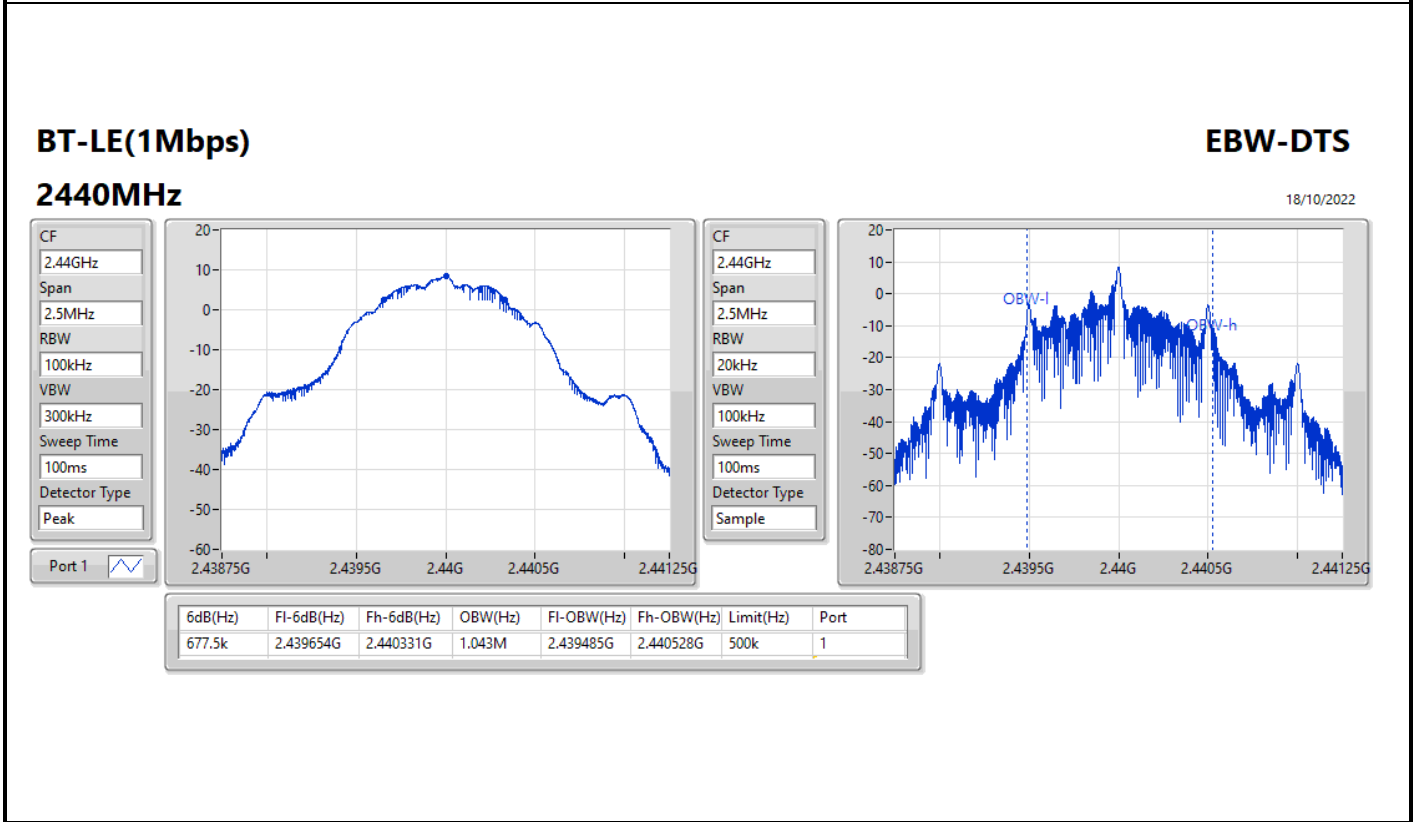
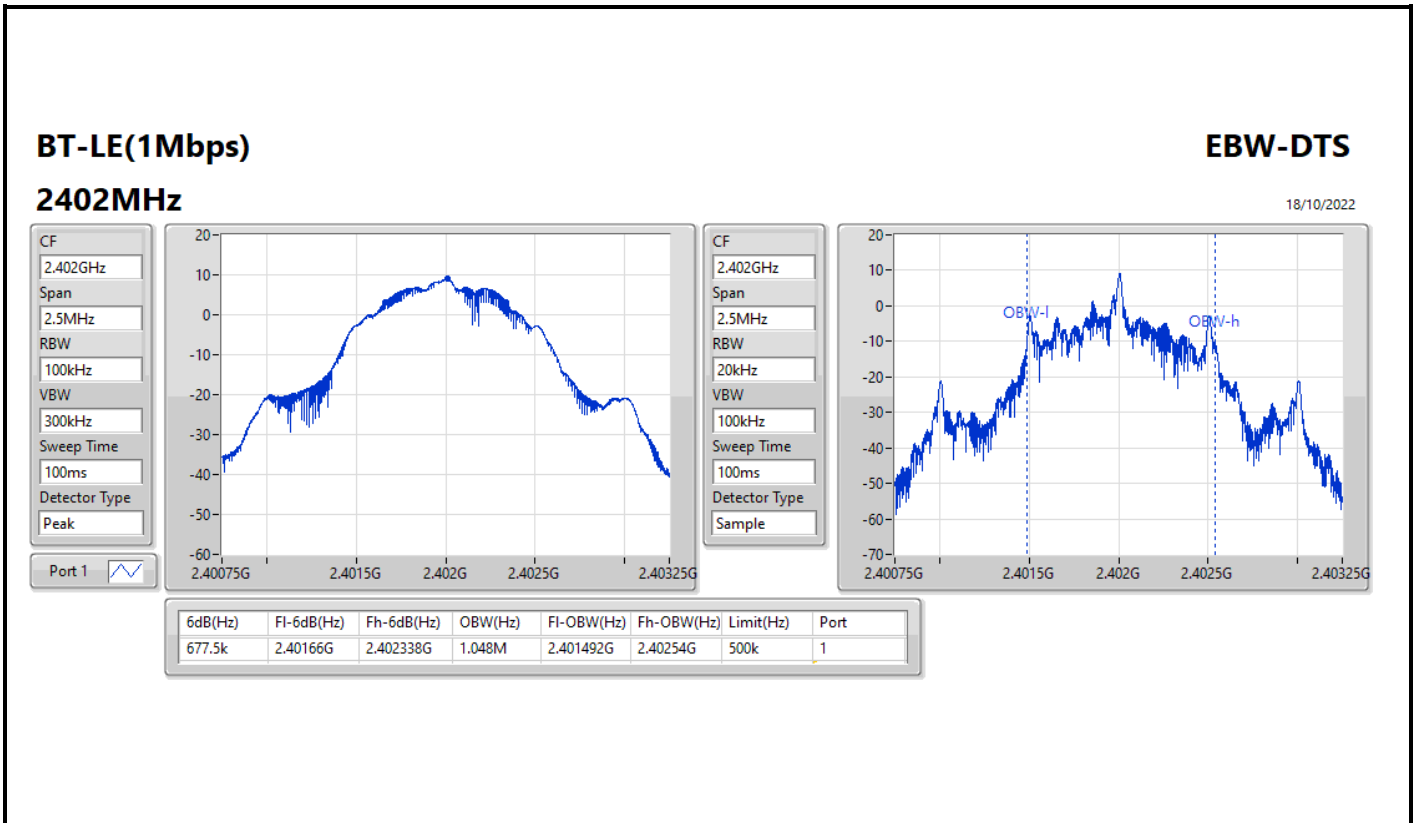

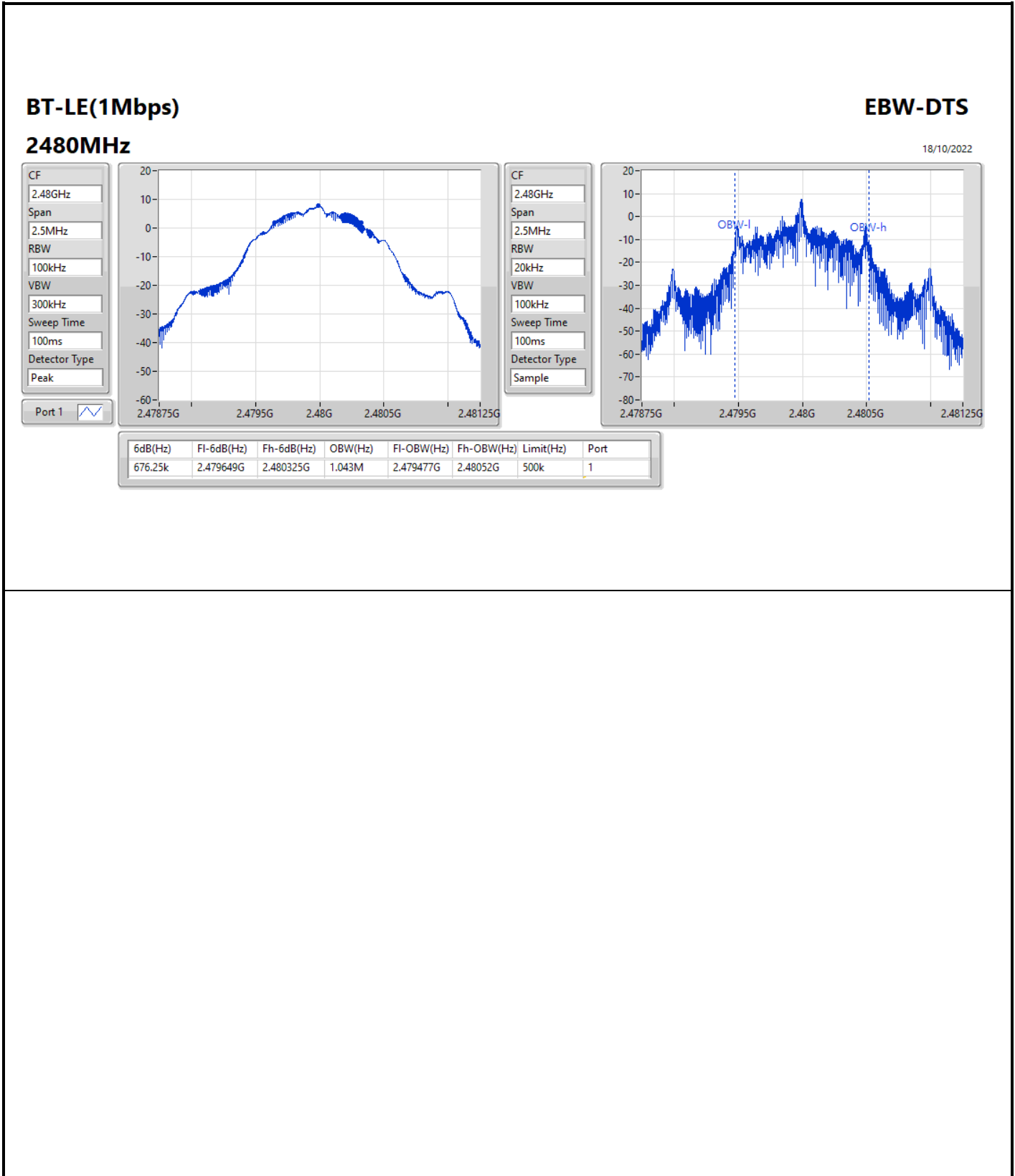



Summary

Mode	Power (dBm)	Power (W)
2.4-2.4835GHz	-	-
BT-LE(1Mbps)	9.39	0.00869



Result

Mode	Result	Gain (dBi)	Power (dBm)	Power Limit (dBm)
BT-LE(1Mbps)	-	-	-	-
2402MHz	Pass	0.86	9.39	30.00
2440MHz	Pass	0.86	8.71	30.00
2480MHz	Pass	0.86	8.00	30.00

DG = Directional Gain; Port X = Port X output power



Summary

Mode	PD (dBm/RBW)
2.4-2.4835GHz	-
BT-LE(1Mbps)	7.32

RBW = 3kHz;



Result

Mode	Result	Gain (dBi)	PD (dBm/RBW)	PD Limit (dBm/RBW)
BT-LE(1Mbps)	-	-	-	-
2402MHz	Pass	0.86	3.53	8.00
2440MHz	Pass	0.86	7.32	8.00
2480MHz	Pass	0.86	6.34	8.00

DG = Directional Gain; RBW = 3kHz;
PD = trace bin-by-bin of each transmits port summing can be performed maximum power density; Port X = Port X Power Density;

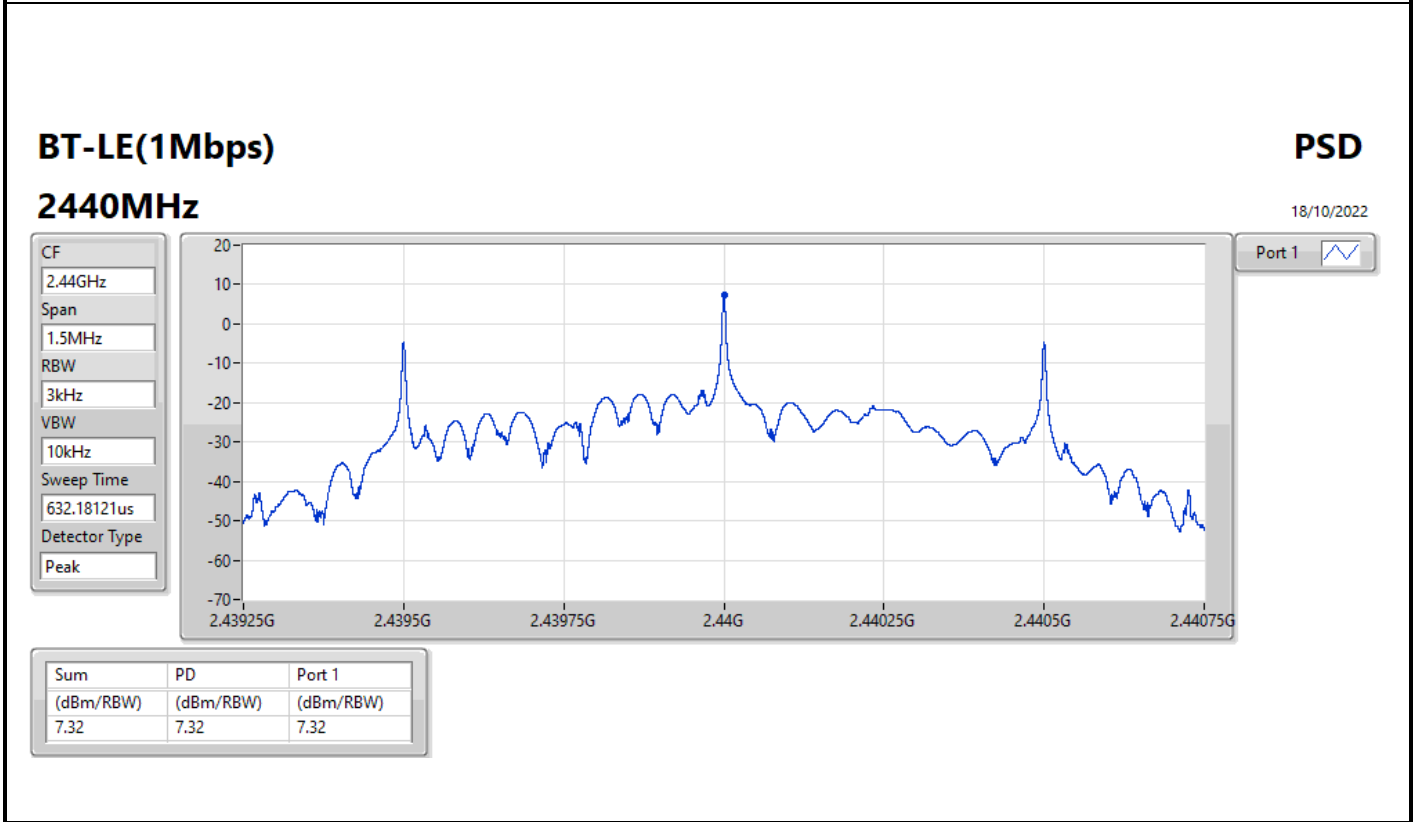
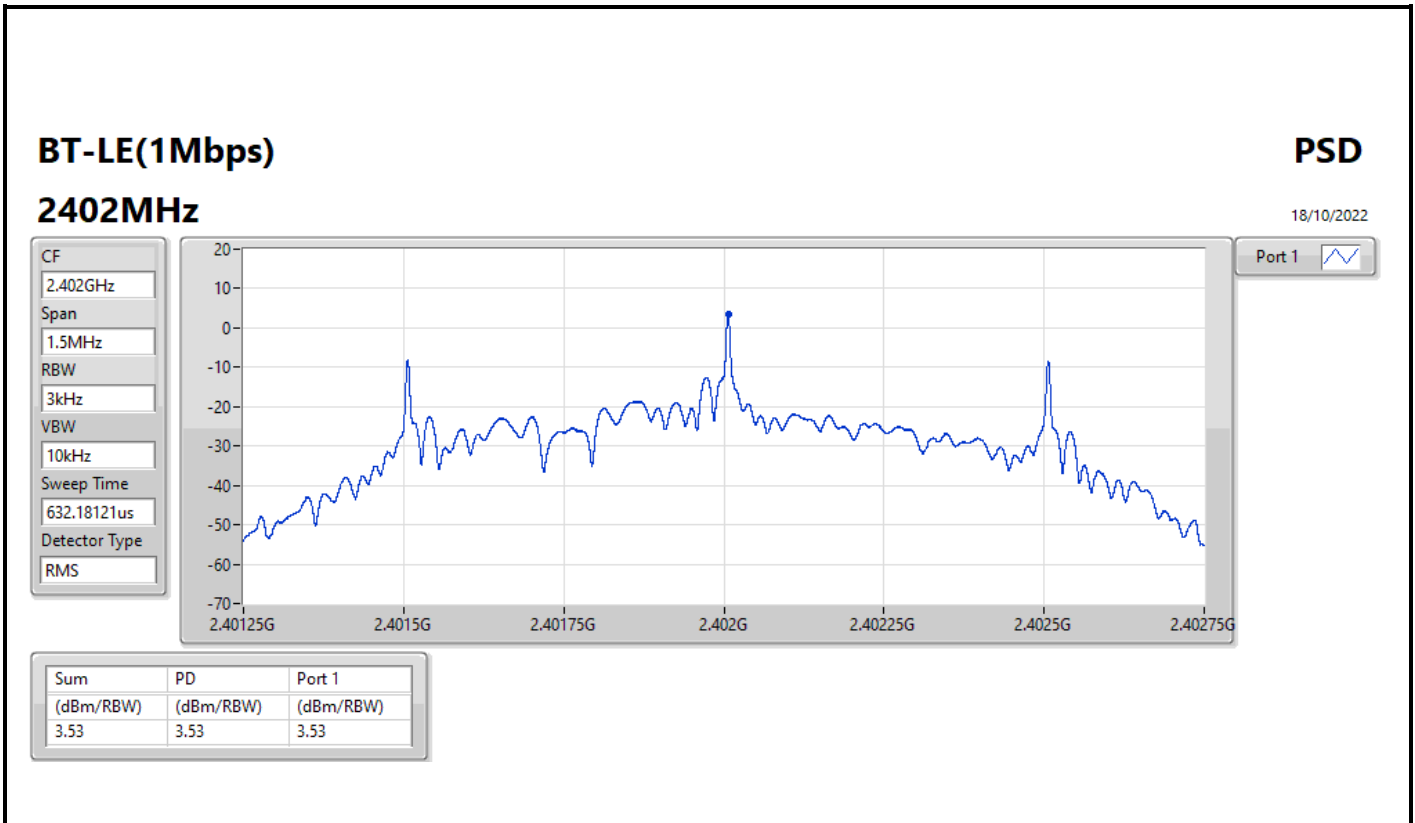

BT-LE(1Mbps)

PSD

2480MHz

18/10/2022

CF
2.48GHz

Span
1.5MHz

RBW
3kHz

VBW
10kHz

Sweep Time
632.18121us

Detector Type
Peak

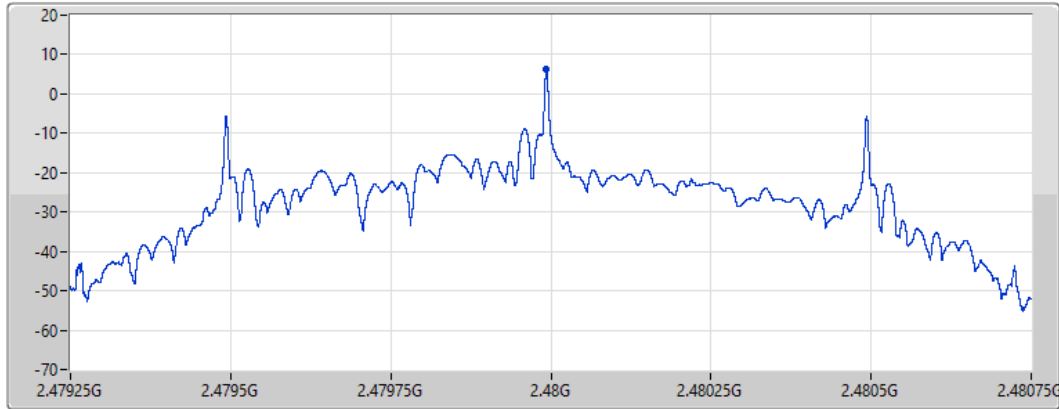

Sum	PD	Port 1
(dBm/RBW)	(dBm/RBW)	(dBm/RBW)
6.34	6.34	6.34



Summary

Mode	Result	Ref (Hz)	Ref (dBm)	Limit (dBm)	Freq (Hz)	Level (dBm)	Freq (Hz)	Level (dBm)	Freq (Hz)	Level (dBm)	Freq (Hz)	Level (dBm)	Freq (Hz)	Level (dBm)	Port
2.4-2.4835GHz	-	-	-	-	-	-	-	-	-	-	-	-	-	-	-
BT-LE(1Mbps)	Pass	2.402G	8.99	-21.01	2.3001G	-54.38	2.3998G	-50.83	2.4G	-48.40	2.50138G	-52.93	15.24214G	-41.61	1



Result

Mode	Result	Ref (Hz)	Ref (dBm)	Limit (dBm)	Freq (Hz)	Level (dBm)	Freq (Hz)	Level (dBm)	Freq (Hz)	Level (dBm)	Freq (Hz)	Level (dBm)	Freq (Hz)	Level (dBm)	Port
BT-LE(1Mbps)	-	-	-	-	-	-	-	-	-	-	-	-	-	-	-
2402MHz	Pass	2.402G	8.99	-21.01	2.3001G	-54.38	2.3998G	-50.83	2.4G	-48.40	2.50138G	-52.93	15.24214G	-41.61	1
2440MHz	Pass	2.402G	8.99	-21.01	2.3048G	-53.96	2.39956G	-52.48	2.4G	-54.86	2.50138G	-51.95	15.16622G	-41.71	1
2480MHz	Pass	2.402G	8.99	-21.01	2.1591G	-53.60	2.39172G	-52.22	2.4G	-55.99	2.50302G	-52.65	15.22808G	-41.24	1

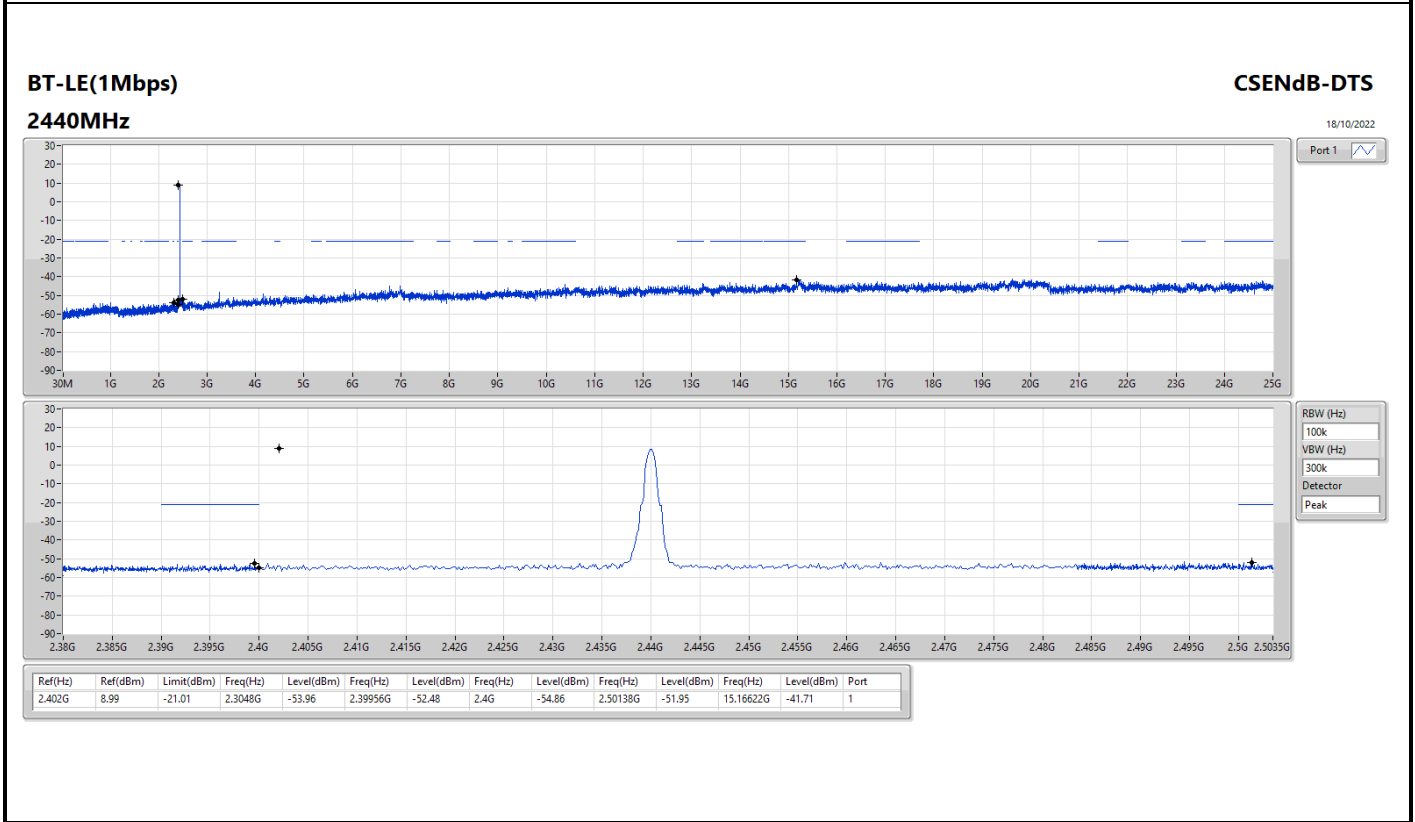
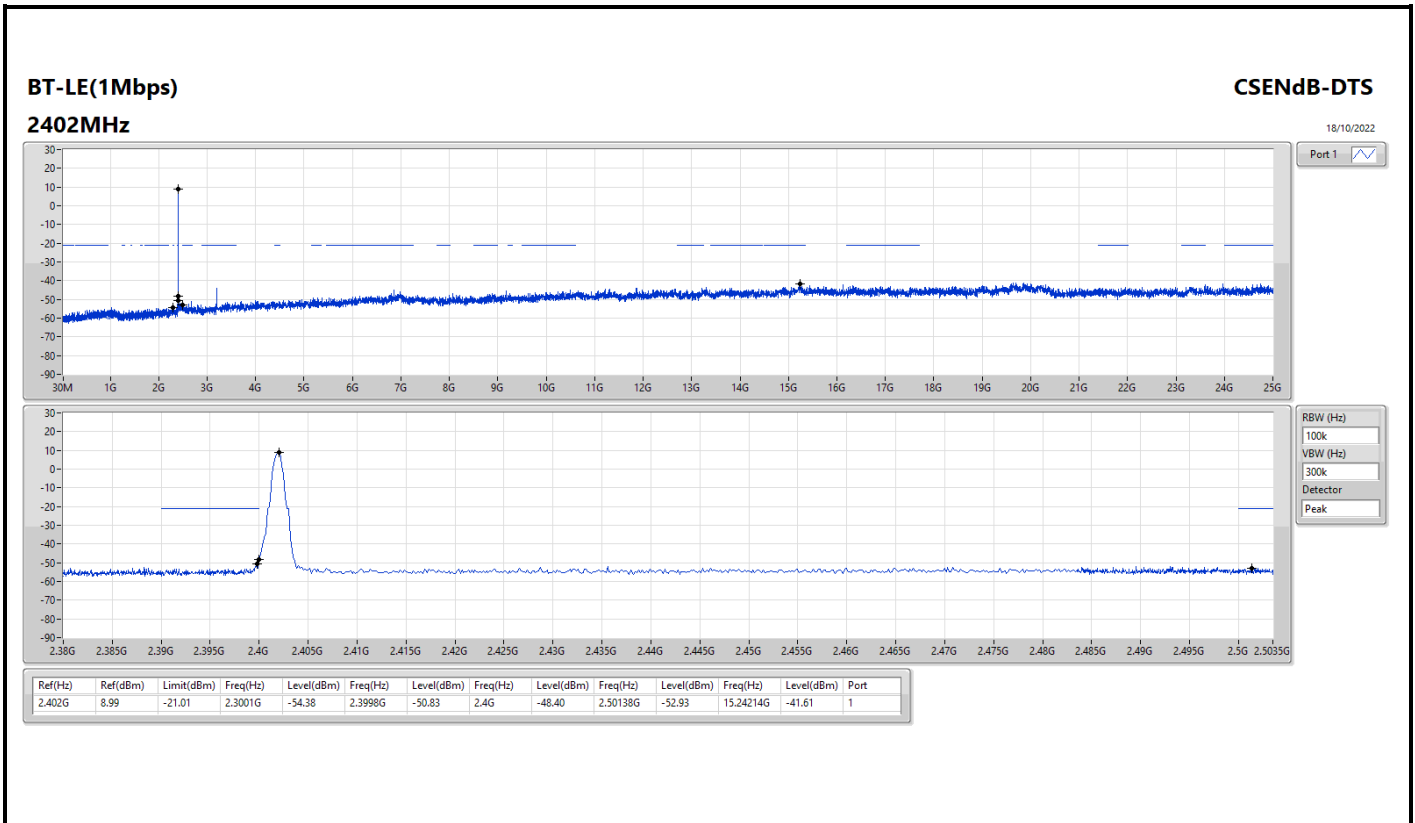

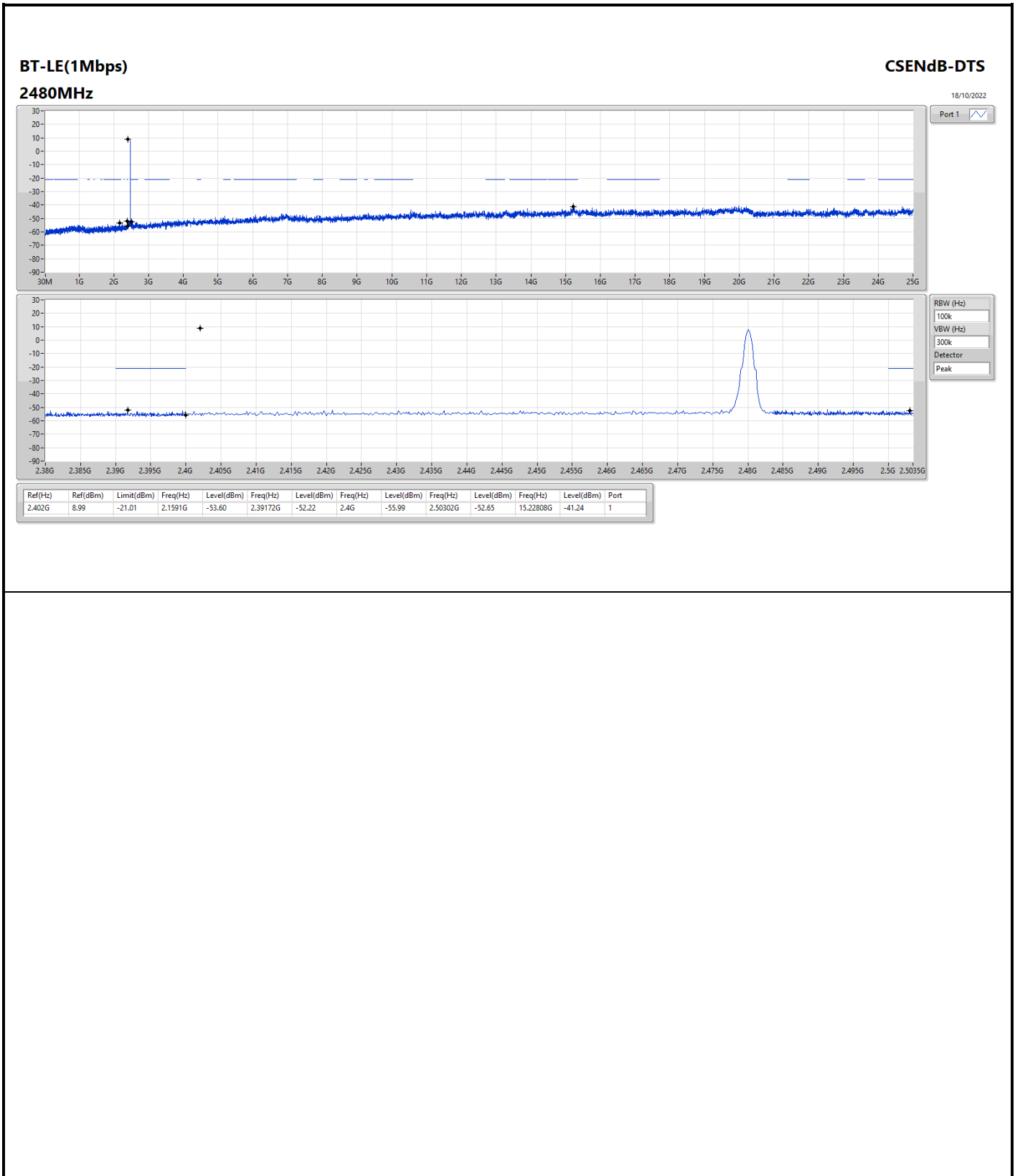



Summary

Mode	Result	Type	Freq (Hz)	Level (dBuV/m)	Limit (dBuV/m)	Margin (dB)	Dist (m)	Condition	Azimuth (°)	Height (m)
2.4-2.4835GHz	-	-	-	-	-	-	-	-	-	-
BT-LE(1Mbps)_RX	Pass	PK	293.84M	41.26	46.00	-4.74	3	Horizontal	0	1.00



Result

Mode	Result	Type	Freq (Hz)	Level (dBuV/m)	Limit (dBuV/m)	Margin (dB)	Dist (m)	Condition	Azimuth (°)	Height (m)
BT-LE(1Mbps)_RX	-	-	-	-	-	-	-	-	-	-
2440MHz	Pass	PK	45.52M	23.07	40.00	-16.93	3	Vertical	360	1.00
2440MHz	Pass	PK	142.52M	26.29	43.50	-17.21	3	Vertical	360	1.00
2440MHz	Pass	PK	177.44M	25.91	43.50	-17.59	3	Vertical	360	1.00
2440MHz	Pass	PK	256.98M	36.15	46.00	-9.85	3	Vertical	360	1.00
2440MHz	Pass	PK	313.24M	35.69	46.00	-10.31	3	Vertical	360	1.00
2440MHz	Pass	PK	456.8M	31.69	46.00	-14.31	3	Vertical	360	1.00
2440MHz	Pass	PK	33.88M	21.83	40.00	-18.17	3	Horizontal	0	1.00
2440MHz	Pass	PK	142.52M	22.26	43.50	-21.24	3	Horizontal	0	1.00
2440MHz	Pass	PK	183.26M	28.19	43.50	-15.31	3	Horizontal	0	1.00
2440MHz	Pass	PK	270.56M	40.23	46.00	-5.77	3	Horizontal	0	1.00
2440MHz	Pass	PK	293.84M	41.26	46.00	-4.74	3	Horizontal	0	1.00
2440MHz	Pass	PK	433.52M	34.31	46.00	-11.69	3	Horizontal	0	1.00

2.4-2.4835GHz_BT-LE(1Mbps)_RX

2440MHz_Transformer

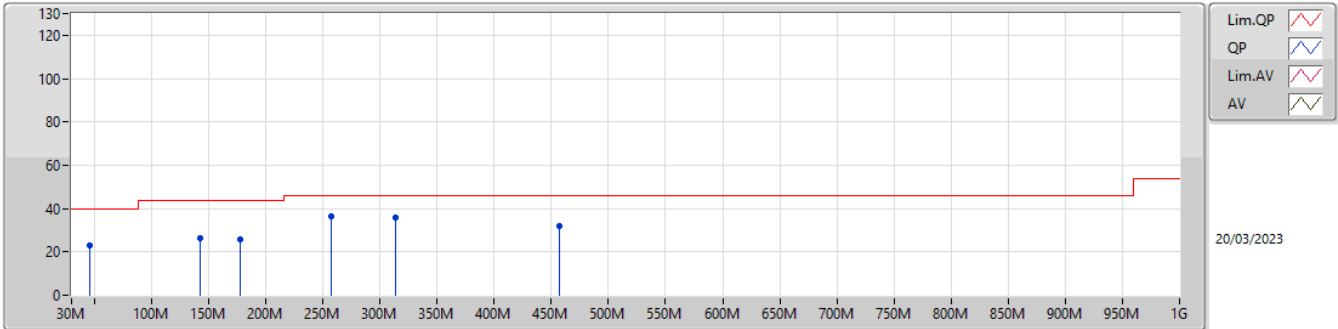

Type	Freq (Hz)	Level (dBuV/m)	Limit (dBuV/m)	Margin (dB)	Factor (dB)	Dist (m)	Condition	Azimuth (°)	Height (m)	Raw (dBuV)	AF (dB)	CL (dB)	PA (dB)
PK	45.52M	23.07	40.00	-16.93	-11.50	3	Vertical	360	1.00	34.57	14.92	1.09	27.51
PK	142.52M	26.29	43.50	-17.21	-8.98	3	Vertical	360	1.00	35.27	16.24	1.96	27.18
PK	177.44M	25.91	43.50	-17.59	-10.25	3	Vertical	360	1.00	36.16	14.56	2.20	27.01
PK	256.98M	36.15	46.00	-9.85	-5.60	3	Vertical	360	1.00	41.75	18.40	2.67	26.67
PK	313.24M	35.69	46.00	-10.31	-5.11	3	Vertical	360	1.00	40.80	18.59	2.98	26.68
PK	456.8M	31.69	46.00	-14.31	-1.70	3	Vertical	360	1.00	33.39	22.27	3.62	27.59

2.4-2.4835GHz_BT-LE(1Mbps)_RX

2440MHz_Transformer

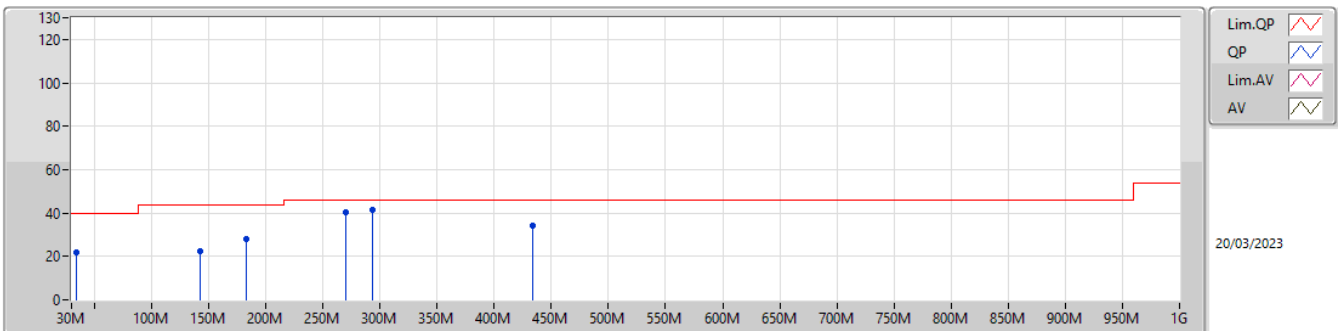

Type	Freq (Hz)	Level (dBuV/m)	Limit (dBuV/m)	Margin (dB)	Factor (dB)	Dist (m)	Condition	Azimuth (°)	Height (m)	Raw (dBuV)	AF (dB)	CL (dB)	PA (dB)
PK	33.88M	21.83	40.00	-18.17	-5.34	3	Horizontal	0	1.00	27.17	21.26	0.93	27.53
PK	142.52M	22.26	43.50	-21.24	-8.98	3	Horizontal	0	1.00	31.24	16.24	1.96	27.18
PK	183.26M	28.19	43.50	-15.31	-10.37	3	Horizontal	0	1.00	38.56	14.36	2.24	26.97
PK	270.56M	40.23	46.00	-5.77	-6.07	3	Horizontal	0	1.00	46.30	17.83	2.75	26.65
PK	293.84M	41.26	46.00	-4.74	-5.56	3	Horizontal	0	1.00	46.82	18.18	2.88	26.62
PK	433.52M	34.31	46.00	-11.69	-2.12	3	Horizontal	0	1.00	36.43	21.80	3.52	27.44



Summary

Mode	Result	Type	Freq (Hz)	Level (dBuV/m)	Limit (dBuV/m)	Margin (dB)	Dist (m)	Condition	Azimuth (°)	Height (m)	Comments
2.4-2.4835GHz	-	-	-	-	-	-	-	-	-	-	-
BT-LE(1Mbps)	Pass	AV	2.4972G	47.44	54.00	-6.56	3	Vertical	254	1.18	-



Result

Mode	Result	Type	Freq (Hz)	Level (dBuV/m)	Limit (dBuV/m)	Margin (dB)	Dist (m)	Condition	Azimuth (°)	Height (m)	Comments
BT-LE(1Mbps)	-	-	-	-	-	-	-	-	-	-	-
2402MHz	Pass	AV	2.374G	46.53	54.00	-7.47	3	Vertical	255	1.01	-
2402MHz	Pass	AV	2.402G	109.14	Inf	-Inf	3	Vertical	255	1.01	-
2402MHz	Pass	PK	2.3604G	59.37	74.00	-14.63	3	Vertical	255	1.01	-
2402MHz	Pass	PK	2.4018G	109.72	Inf	-Inf	3	Vertical	255	1.01	-
2402MHz	Pass	AV	2.3858G	46.56	54.00	-7.44	3	Horizontal	318	2.59	-
2402MHz	Pass	AV	2.402G	103.52	Inf	-Inf	3	Horizontal	318	2.59	-
2402MHz	Pass	PK	2.3594G	59.20	74.00	-14.80	3	Horizontal	318	2.59	-
2402MHz	Pass	PK	2.4022G	104.06	Inf	-Inf	3	Horizontal	318	2.59	-
2402MHz	Pass	AV	4.80178G	32.22	54.00	-21.78	3	Vertical	133	1.46	-
2402MHz	Pass	PK	4.80565G	45.14	74.00	-28.86	3	Vertical	133	1.46	-
2402MHz	Pass	AV	4.80339G	32.32	54.00	-21.68	3	Horizontal	305	2.19	-
2402MHz	Pass	PK	4.804G	44.51	74.00	-29.49	3	Horizontal	305	2.19	-
2440MHz	Pass	AV	2.37G	46.64	54.00	-7.36	3	Vertical	255	1.04	-
2440MHz	Pass	AV	2.44G	107.87	Inf	-Inf	3	Vertical	255	1.04	-
2440MHz	Pass	AV	2.4872G	47.10	54.00	-6.90	3	Vertical	255	1.04	-
2440MHz	Pass	PK	2.3684G	59.00	74.00	-15.00	3	Vertical	255	1.04	-
2440MHz	Pass	PK	2.4396G	108.43	Inf	-Inf	3	Vertical	255	1.04	-
2440MHz	Pass	PK	2.4868G	59.41	74.00	-14.59	3	Vertical	255	1.04	-
2440MHz	Pass	AV	2.3832G	46.67	54.00	-7.33	3	Horizontal	325	1.31	-
2440MHz	Pass	AV	2.44G	101.99	Inf	-Inf	3	Horizontal	325	1.31	-
2440MHz	Pass	AV	2.4852G	47.24	54.00	-6.76	3	Horizontal	325	1.31	-
2440MHz	Pass	PK	2.362G	59.65	74.00	-14.35	3	Horizontal	325	1.31	-
2440MHz	Pass	PK	2.4396G	102.53	Inf	-Inf	3	Horizontal	325	1.31	-
2440MHz	Pass	PK	2.4852G	59.42	74.00	-14.58	3	Horizontal	325	1.31	-
2440MHz	Pass	AV	4.88249G	31.69	54.00	-22.31	3	Vertical	132	2.51	-
2440MHz	Pass	PK	4.88118G	44.22	74.00	-29.78	3	Vertical	132	2.51	-
2440MHz	Pass	AV	4.88242G	31.82	54.00	-22.18	3	Horizontal	286	1.65	-
2440MHz	Pass	PK	4.8821G	44.78	74.00	-29.22	3	Horizontal	286	1.65	-
2480MHz	Pass	AV	2.48G	105.88	Inf	-Inf	3	Vertical	254	1.18	-
2480MHz	Pass	AV	2.4972G	47.44	54.00	-6.56	3	Vertical	254	1.18	-
2480MHz	Pass	PK	2.4798G	106.50	Inf	-Inf	3	Vertical	254	1.18	-
2480MHz	Pass	PK	2.497G	59.57	74.00	-14.43	3	Vertical	254	1.18	-
2480MHz	Pass	AV	2.48G	99.31	Inf	-Inf	3	Horizontal	321	1.74	-
2480MHz	Pass	AV	2.493G	47.00	54.00	-7.00	3	Horizontal	321	1.74	-
2480MHz	Pass	PK	2.4798G	99.90	Inf	-Inf	3	Horizontal	321	1.74	-
2480MHz	Pass	PK	2.4916G	59.22	74.00	-14.78	3	Horizontal	321	1.74	-
2480MHz	Pass	AV	4.95994G	33.87	54.00	-20.13	3	Vertical	116	1.82	-
2480MHz	Pass	PK	4.95972G	46.35	74.00	-27.65	3	Vertical	116	1.82	-
2480MHz	Pass	AV	4.96061G	33.59	54.00	-20.41	3	Horizontal	212	1.50	-
2480MHz	Pass	PK	4.95999G	46.95	74.00	-27.05	3	Horizontal	212	1.50	-

BT-LE(1Mbps)

2402MHz_TX

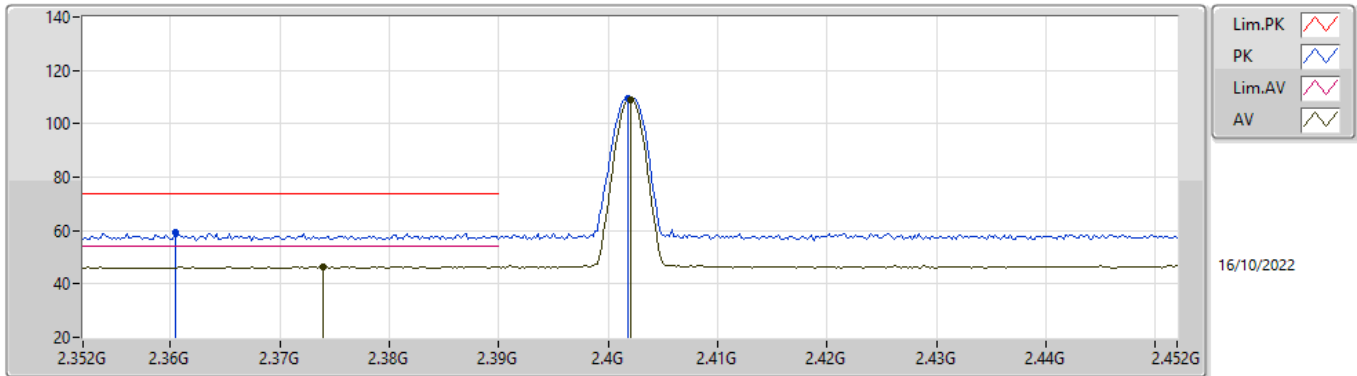

Type	Freq (Hz)	Level (dBuV/m)	Limit (dBuV/m)	Margin (dB)	Factor (dB)	Dist (m)	Condition	Azimuth (°)	Height (m)	Comment	Raw (dBuV)	AF (dB)	CL (dB)	PA (dB)
AV	2.374G	46.53	54.00	-7.47	31.93	3	Vertical	255	1.01	-	14.60	27.44	4.49	-
AV	2.402G	109.14	Inf	-Inf	32.07	3	Vertical	255	1.01	-	77.07	27.60	4.47	-
PK	2.3604G	59.37	74.00	-14.63	31.85	3	Vertical	255	1.01	-	27.52	27.36	4.49	-
PK	2.4018G	109.72	Inf	-Inf	32.07	3	Vertical	255	1.01	-	77.65	27.60	4.47	-

BT-LE(1Mbps)

2402MHz_TX

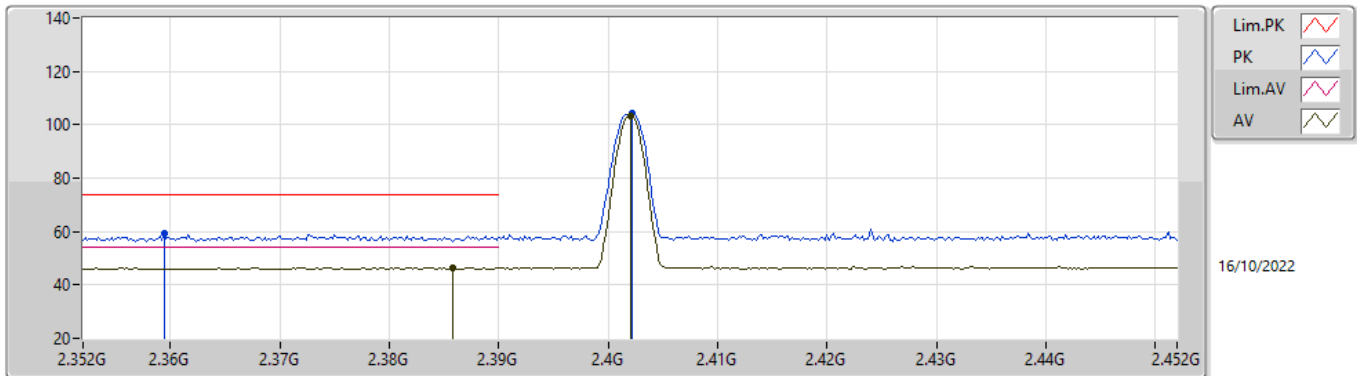

Type	Freq (Hz)	Level (dBuV/m)	Limit (dBuV/m)	Margin (dB)	Factor (dB)	Dist (m)	Condition	Azimuth (°)	Height (m)	Comment	Raw (dBuV)	AF (dB)	CL (dB)	PA (dB)
AV	2.3858G	46.56	54.00	-7.44	31.99	3	Horizontal	318	2.59	-	14.57	27.51	4.48	-
AV	2.402G	103.52	Inf	-Inf	32.07	3	Horizontal	318	2.59	-	71.45	27.60	4.47	-
PK	2.3594G	59.20	74.00	-14.80	31.85	3	Horizontal	318	2.59	-	27.35	27.36	4.49	-
PK	2.4022G	104.06	Inf	-Inf	32.07	3	Horizontal	318	2.59	-	71.99	27.60	4.47	-

BT-LE(1Mbps)
2402MHz_TX

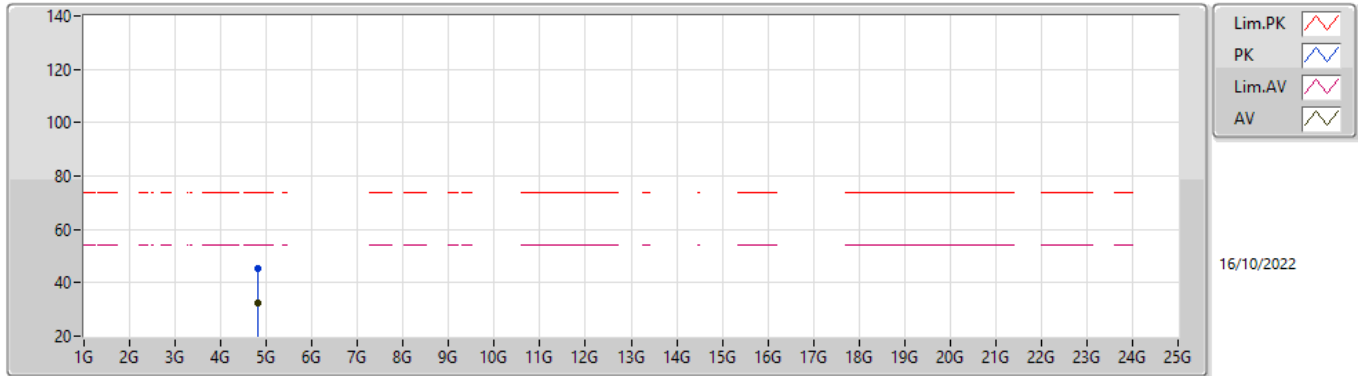

Type	Freq (Hz)	Level (dBuV/m)	Limit (dBuV/m)	Margin (dB)	Factor (dB)	Dist (m)	Condition	Azimuth (°)	Height (m)	Comment	Raw (dBuV)	AF (dB)	CL (dB)	PA (dB)
AV	4.80178G	32.22	54.00	-21.78	4.92	3	Vertical	133	1.46	-	27.30	32.31	6.90	34.29
PK	4.80565G	45.14	74.00	-28.86	4.94	3	Vertical	133	1.46	-	40.20	32.33	6.90	34.29

BT-LE(1Mbps)
2402MHz_TX

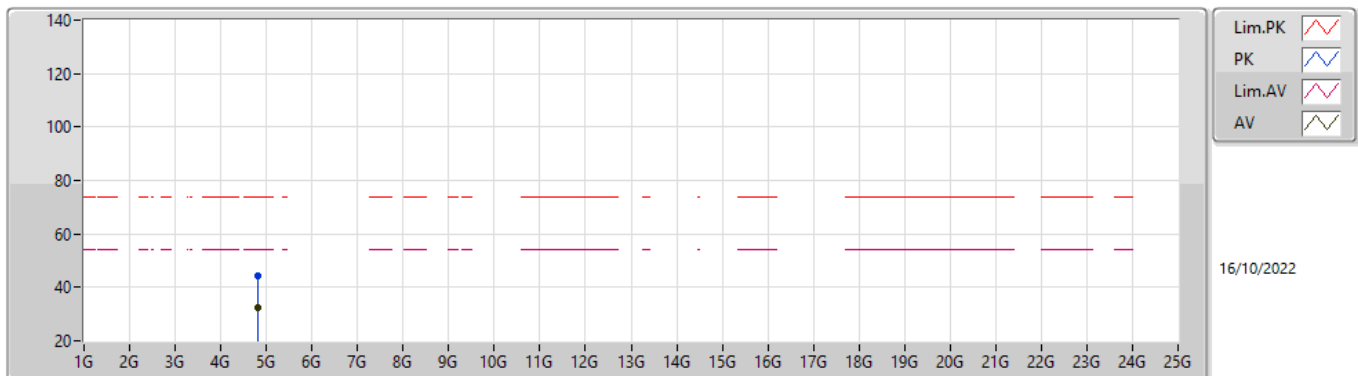

Type	Freq (Hz)	Level (dBuV/m)	Limit (dBuV/m)	Margin (dB)	Factor (dB)	Dist (m)	Condition	Azimuth (°)	Height (m)	Comment	Raw (dBuV)	AF (dB)	CL (dB)	PA (dB)
AV	4.80339G	32.32	54.00	-21.68	4.93	3	Horizontal	305	2.19	-	27.39	32.32	6.90	34.29
PK	4.804G	44.51	74.00	-29.49	4.93	3	Horizontal	305	2.19	-	39.58	32.32	6.90	34.29

BT-LE(1Mbps)
2440MHz_TX

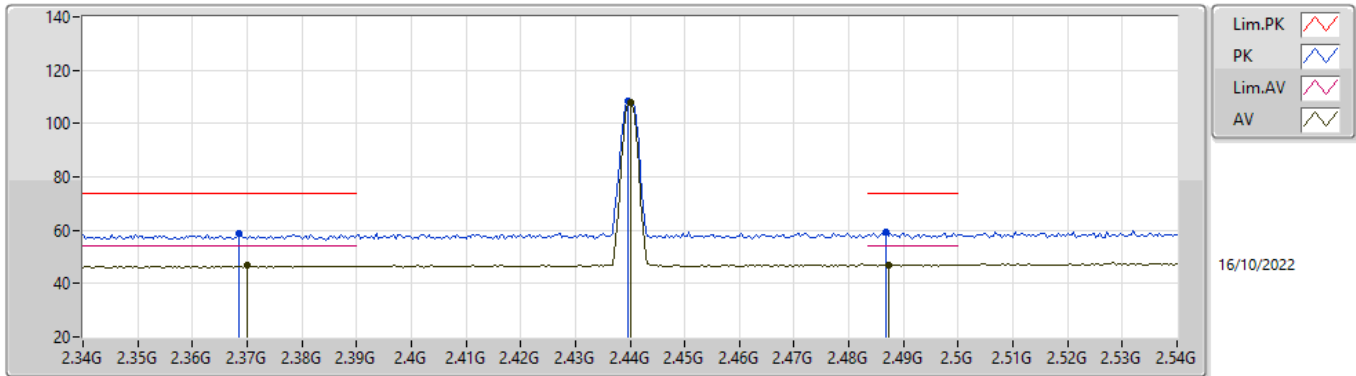

Type	Freq (Hz)	Level (dBuV/m)	Limit (dBuV/m)	Margin (dB)	Factor (dB)	Dist (m)	Condition	Azimuth (°)	Height (m)	Comment	Raw (dBuV)	AF (dB)	CL (dB)	PA (dB)
AV	2.37G	46.64	54.00	-7.36	31.91	3	Vertical	255	1.04	-	14.73	27.42	4.49	-
AV	2.44G	107.87	Inf	-Inf	32.16	3	Vertical	255	1.04	-	75.71	27.68	4.48	-
AV	2.4872G	47.10	54.00	-6.90	32.40	3	Vertical	255	1.04	-	14.70	27.92	4.48	-
PK	2.3684G	59.00	74.00	-15.00	31.90	3	Vertical	255	1.04	-	27.10	27.41	4.49	-
PK	2.4396G	108.43	Inf	-Inf	32.16	3	Vertical	255	1.04	-	76.27	27.68	4.48	-
PK	2.4868G	59.41	74.00	-14.59	32.40	3	Vertical	255	1.04	-	27.01	27.92	4.48	-

BT-LE(1Mbps)
2440MHz_TX

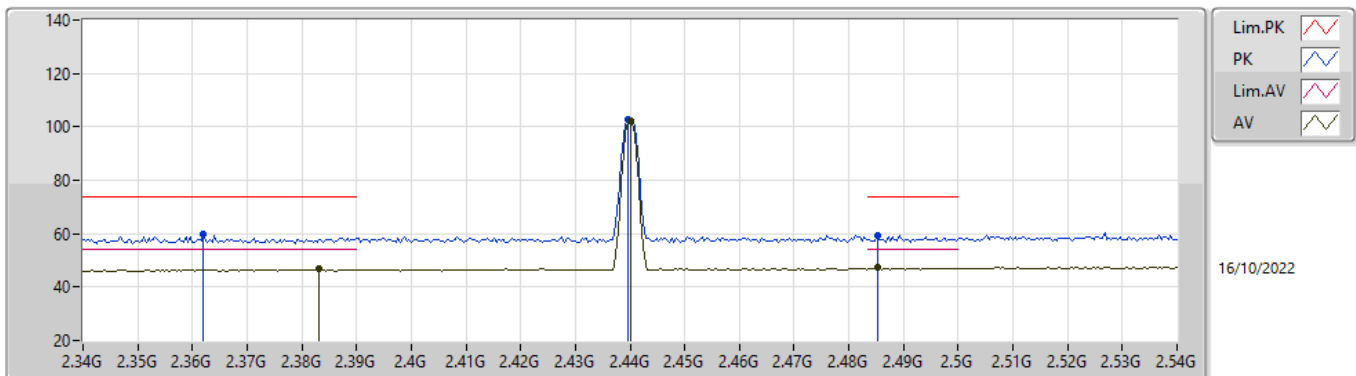

Type	Freq (Hz)	Level (dBuV/m)	Limit (dBuV/m)	Margin (dB)	Factor (dB)	Dist (m)	Condition	Azimuth (°)	Height (m)	Comment	Raw (dBuV)	AF (dB)	CL (dB)	PA (dB)
AV	2.3832G	46.67	54.00	-7.33	31.98	3	Horizontal	325	1.31	-	14.69	27.50	4.48	-
AV	2.44G	101.99	Inf	-Inf	32.16	3	Horizontal	325	1.31	-	69.83	27.68	4.48	-
AV	2.4852G	47.24	54.00	-6.76	32.39	3	Horizontal	325	1.31	-	14.85	27.91	4.48	-
PK	2.362G	59.65	74.00	-14.35	31.86	3	Horizontal	325	1.31	-	27.79	27.37	4.49	-
PK	2.4396G	102.53	Inf	-Inf	32.16	3	Horizontal	325	1.31	-	70.37	27.68	4.48	-
PK	2.4852G	59.42	74.00	-14.58	32.39	3	Horizontal	325	1.31	-	27.03	27.91	4.48	-

BT-LE(1Mbps)
2440MHz_TX

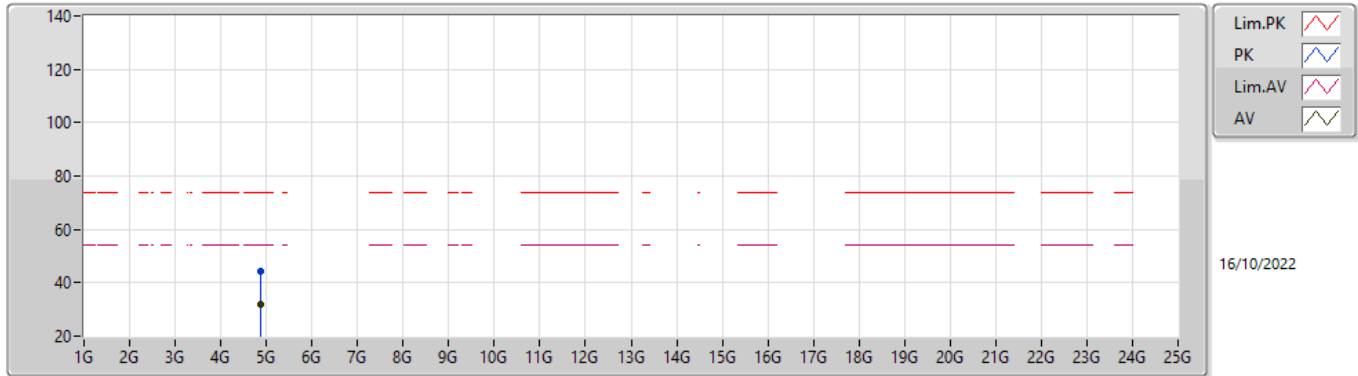

Type	Freq (Hz)	Level (dBuV/m)	Limit (dBuV/m)	Margin (dB)	Factor (dB)	Dist (m)	Condition	Azimuth (°)	Height (m)	Comment	Raw (dBuV)	AF (dB)	CL (dB)	PA (dB)
AV	4.88249G	31.69	54.00	-22.31	5.35	3	Vertical	132	2.51	-	26.34	32.73	6.90	34.28
PK	4.88118G	44.22	74.00	-29.78	5.34	3	Vertical	132	2.51	-	38.88	32.72	6.90	34.28

BT-LE(1Mbps)
2440MHz_TX

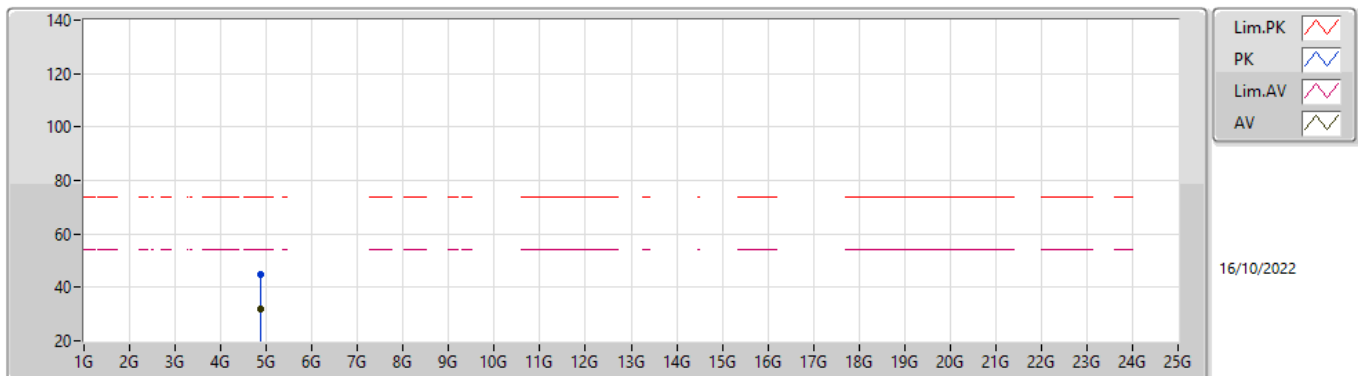

Type	Freq (Hz)	Level (dBuV/m)	Limit (dBuV/m)	Margin (dB)	Factor (dB)	Dist (m)	Condition	Azimuth (°)	Height (m)	Comment	Raw (dBuV)	AF (dB)	CL (dB)	PA (dB)
AV	4.88242G	31.82	54.00	-22.18	5.35	3	Horizontal	286	1.65	-	26.47	32.73	6.90	34.28
PK	4.8821G	44.78	74.00	-29.22	5.35	3	Horizontal	286	1.65	-	39.43	32.73	6.90	34.28

BT-LE(1Mbps)

2480MHz_TX

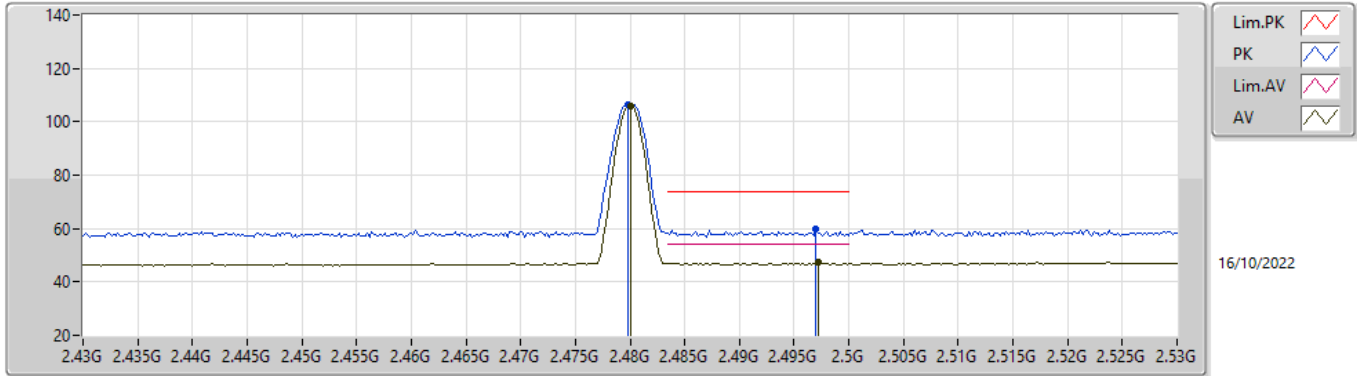

Type	Freq (Hz)	Level (dBuV/m)	Limit (dBuV/m)	Margin (dB)	Factor (dB)	Dist (m)	Condition	Azimuth (°)	Height (m)	Comment	Raw (dBuV)	AF (dB)	CL (dB)	PA (dB)
AV	2.48G	105.88	Inf	-Inf	32.36	3	Vertical	254	1.18	-	73.52	27.88	4.48	-
AV	2.4972G	47.44	54.00	-6.56	32.46	3	Vertical	254	1.18	-	14.98	27.98	4.48	-
PK	2.4798G	106.50	Inf	-Inf	32.36	3	Vertical	254	1.18	-	74.14	27.88	4.48	-
PK	2.497G	59.57	74.00	-14.43	32.46	3	Vertical	254	1.18	-	27.11	27.98	4.48	-

BT-LE(1Mbps)

2480MHz_TX

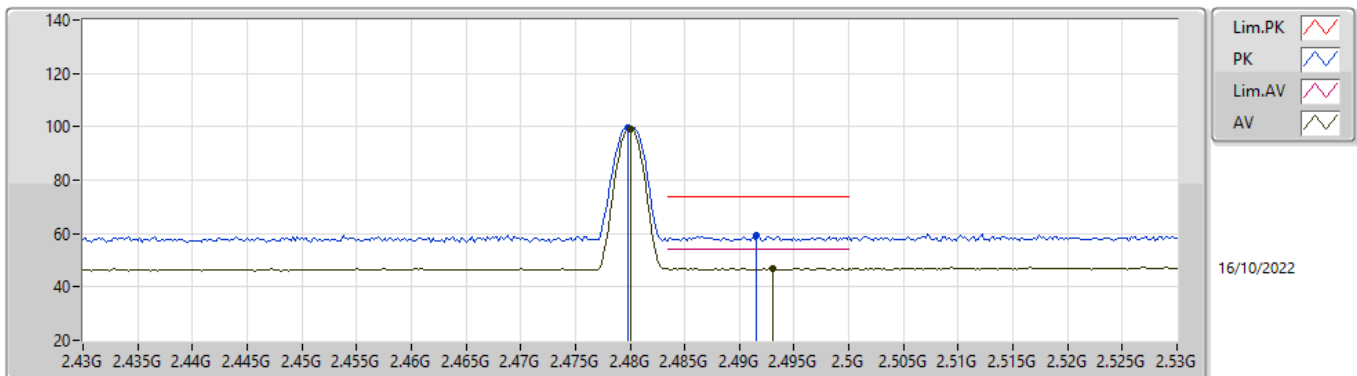

Type	Freq (Hz)	Level (dBuV/m)	Limit (dBuV/m)	Margin (dB)	Factor (dB)	Dist (m)	Condition	Azimuth (°)	Height (m)	Comment	Raw (dBuV)	AF (dB)	CL (dB)	PA (dB)
AV	2.48G	99.31	Inf	-Inf	32.36	3	Horizontal	321	1.74	-	66.95	27.88	4.48	-
AV	2.493G	47.00	54.00	-7.00	32.44	3	Horizontal	321	1.74	-	14.56	27.96	4.48	-
PK	2.4798G	99.90	Inf	-Inf	32.36	3	Horizontal	321	1.74	-	67.54	27.88	4.48	-
PK	2.4916G	59.22	74.00	-14.78	32.43	3	Horizontal	321	1.74	-	26.79	27.95	4.48	-

BT-LE(1Mbps)
2480MHz_TX

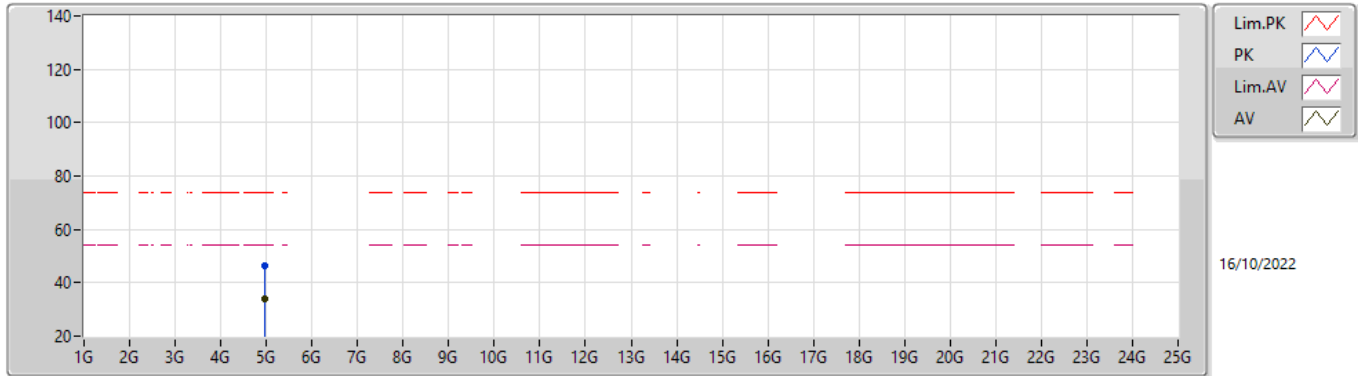

Type	Freq (Hz)	Level (dBuV/m)	Limit (dBuV/m)	Margin (dB)	Factor (dB)	Dist (m)	Condition	Azimuth (°)	Height (m)	Comment	Raw (dBuV)	AF (dB)	CL (dB)	PA (dB)
AV	4.95994G	33.87	54.00	-20.13	5.76	3	Vertical	116	1.82	-	28.11	33.12	6.91	34.27
PK	4.95972G	46.35	74.00	-27.65	5.76	3	Vertical	116	1.82	-	40.59	33.12	6.91	34.27

BT-LE(1Mbps)
2480MHz_TX

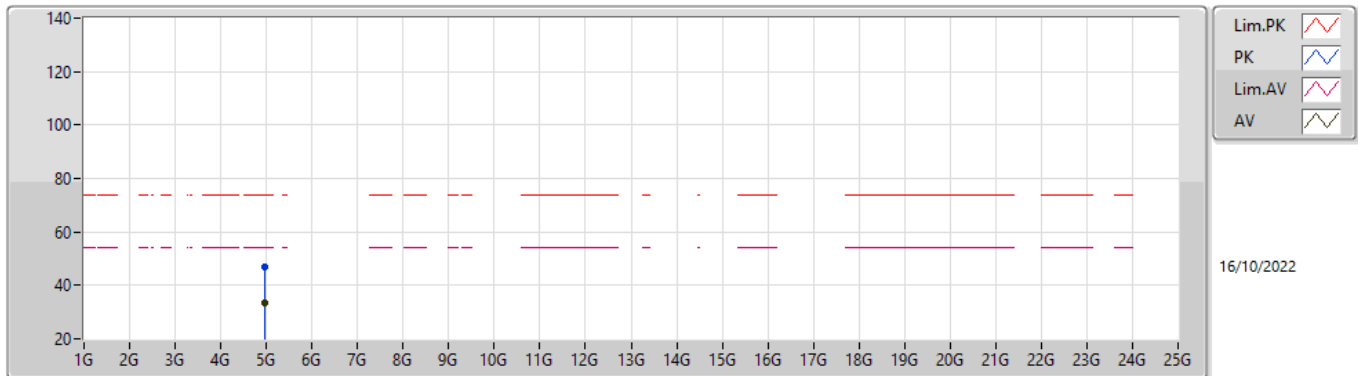

Type	Freq (Hz)	Level (dBuV/m)	Limit (dBuV/m)	Margin (dB)	Factor (dB)	Dist (m)	Condition	Azimuth (°)	Height (m)	Comment	Raw (dBuV)	AF (dB)	CL (dB)	PA (dB)
AV	4.96061G	33.59	54.00	-20.41	5.76	3	Horizontal	212	1.50	-	27.83	33.12	6.91	34.27
PK	4.95999G	46.95	74.00	-27.05	5.76	3	Horizontal	212	1.50	-	41.19	33.12	6.91	34.27