



Engineering Solutions & Electromagnetic Compatibility Services

**FCC Class 2 & ISED Class 3 Permissive Change Report**

<b>Test Lab:</b> Rhein Tech Laboratories, Inc.      Tel: 703-689-0368 360 Herndon Parkway                      Fax: 703-689-2056 Suite 1400                                      www.rheintech.com Herndon, VA 20170 E-Mail: atcbinfo@rheintech.com		<b>Applicant:</b> Alarm.com                                      Tel: 703-584-7319 8281 Greensboro Drive Suite 100 Tysons, VA 22102	
<b>FCC ID</b>	YL6-143470L	<b>Test Report Date</b>	June 28, 2017
<b>IC</b>	9111A-143470L	<b>RTL Work Order #</b>	2017110
<b>Model #</b>	ADC-470L	<b>RTL Quote #</b>	QRTL17-110A
<b>American National Standard Institute</b>	ANSI C63.10-2013: American National Standard of Procedures for Compliance Testing of Unlicensed Wireless Devices		
<b>FCC Classification</b>	DXT – Part 15 Low Power Transceiver		
<b>FCC Rule Part(s)/ Guidance</b>	15.249: Operation within the bands 902-928 MHz, 2400-2483.5 MHz, 5725-5875 MHz, and 24.0-24.25 GHz (10/01/2016)		
<b>Industry Canada</b>	RSS-210 Issue 9: Licence-Exempt Radio Apparatus: Category I Equipment		
<b>Frequency Range (MHz)</b>	<b>Output Power (W)</b>	<b>Frequency Tolerance</b>	<b>Emission Designator</b>
916.0	N/A	N/A	111KF1D

I, the undersigned, hereby declare that the equipment tested and referenced in this report conforms to the identified standard(s) as described in this test report. No modifications were made to the equipment during testing in order to achieve compliance with these standards. Furthermore, there was no deviation from, additions to, or exclusions from, the applicable parts of FCC Part 2, FCC Part 15, RSS-210, RSS-Gen, and ANSI C63.10.

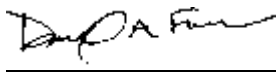
Signature: 

Date: June 28, 2017

Typed/Printed Name: Desmond A. Fraser

Position: President

*This report may not be reproduced, except in full, without the written approval of Rhein Tech Laboratories, Inc. and Alarm.com. The test results relate only to the item(s) tested.*

*These test(s) are accredited under Rhein Tech Laboratories, Inc. ISO/IEC 17025 accreditation issued by ANAB. Refer to certificate and scope of accreditation AT-1445.*

---

## Table of Contents

---

1	General Information.....	4
1.1	Scope .....	4
1.2	Description of EUT .....	4
1.3	Test Facility.....	4
1.4	Related Submittal(s)/Grant(s) .....	4
1.5	Modifications .....	4
2	Test Information .....	5
2.1	Description of Test Modes.....	5
2.2	Exercising the EUT.....	5
2.3	Test Result Summary.....	5
2.4	Test System Details .....	5
2.5	Configuration of Tested System.....	6
3	Radiated Emissions – FCC 15.209, 15.249(a); RSS-210 B.10; RSS-Gen.....	7
3.1	Limits of Radiated Emissions Measurement.....	7
3.1.1	Radiated Emissions Measurement Test Procedure.....	7
3.2	Radiated Emissions Test Results .....	8
3.3	Radiated Emissions Harmonics/Spurious Test Data .....	8
4	AC Conducted Emissions - FCC 15.207; RSS-Gen 8.8: Conducted Limits.....	10
4.1	Site and Test Description.....	10
4.2	Test Limits.....	10
4.3	Conducted Emissions Test Data.....	11
5	99% Bandwidth – IC RSS-Gen 6.6 .....	13
5.1	99% Bandwidth Test Procedure .....	13
5.2	99% Bandwidth Test Data .....	13
5.3	99% Bandwidth Plots .....	14
6	Conclusion .....	14

---

### Figure Index

---

Figure 2-1: Configuration of System Under Test .....	6
--	---

---

### Table Index

---

Table 2-1: Channels Tested .....	5
Table 2-2: Test Result Summary .....	5
Table 2-3: Equipment Under Test .....	5
Table 3-1: Radiated Emissions Test Equipment .....	8
Table 3-2: Radiated Emissions Test Data – Quasi-Peak .....	8
Table 3-3: Radiated Emissions Harmonics/Spurious – 916 MHz; Peak .....	8
Table 3-4: Radiated Emissions Harmonics/Spurious – 916 MHz; Average .....	9
Table 4-1: Conducted Emissions Test Equipment .....	10
Table 4-2: Conducted Emissions Positive Level Check .....	11
Table 4-3: Conducted Emissions Negative Level Check .....	12
Table 5-1: 99% Bandwidth Test Equipment .....	13
Table 5-2: 99% Bandwidth Test Data .....	13

---

### Plot Index

---

Plot 4-1: Conducted Emissions Transmit - +3.9VDC .....	11
Plot 4-2: Conducted Emissions Transmit – VDC Return .....	12
Plot 5-1: 99% Bandwidth; 916 MHz .....	14

---

### Appendix Index

---

Appendix A: Test Photographs .....	15
Appendix B: Description of Change .....	21
Appendix C: Agency Authorization Letter .....	22
Appendix D: ISED Letters .....	23

---

### Photograph Index

---

Photograph 1: Radiated Emissions Testing – Front View (Digital Emissions, <1 GHz) .....	15
Photograph 2: Radiated Emissions Testing – Back View (Digital Emissions, <1 GHz) .....	16
Photograph 3: Radiated Emissions Testing – Front View (Spurious Emissions, >1 GHz) .....	17
Photograph 4: Radiated Emissions Testing – Back View (Spurious Emissions, >1 GHz) .....	18
Photograph 5: Conducted Emissions Testing – Front View .....	19
Photograph 6: Conducted Emissions Testing – Back View .....	20

## 1 General Information

### 1.1 Scope

This is a FCC Class 2 permissive change and ISED Class 3 permissive change application request.

Applicable Standards:

- FCC Part 15.249: Operation within the bands 902-928 MHz, 2400-2483.5 MHz, 5725-5875 MHz, and 24.0-24.25 GHz
- Industry Canada RSS-210: Licence-Exempt Radio Apparatus: Category I Equipment

### 1.2 Description of EUT

<b>Equipment Under Test</b>	Multisensor Transceiver
<b>Model</b>	ADC-470L
<b>Power Supply</b>	9-12VDC
<b>Modulation Type</b>	2FSK
<b>Frequency Range</b>	916.0 MHz
<b>Antenna Type</b>	Copper Wire Monopole

### 1.3 Test Facility

The open area test site and conducted measurement facility used to collect the radiated data is located at 360 Herndon Parkway, Suite 1400, Herndon, Virginia 20170. This site has been fully described in a report and approved by the Federal Communications Commission to perform AC line conducted and radiated emissions testing.

### 1.4 Related Submittal(s)/Grant(s)

This is a Class 2/Class 3 permissive change application for Modular Approval for Alarm.com Model ADC-470L, FCC ID: YL6-143470L, IC: 9111A-143470L.

### 1.5 Modifications

None.

## 2 Test Information

### 2.1 Description of Test Modes

In accordance with FCC 15.31(m), the following frequency was tested:

**Table 2-1: Channels Tested**

Frequency (MHz)
916.0

### 2.2 Exercising the EUT

The EUT was programmed for continuous transmission at 916 MHz. The EUT was tested in all three orthogonal planes in order to determine worst-case emissions. The carrier was also checked to verify that information was being transmitted.

### 2.3 Test Result Summary

**Table 2-2: Test Result Summary**

Test	FCC Reference	IC Reference	Pass/Fail or N/A
AC Power Conducted Emissions	15.207	RSS-Gen Issue 4 8.8	Pass
Radiated Emissions	15.209	RSS-Gen Issue 4 8.9/8.10	Pass
Field Strength of Fundamental and Harmonics	15.249(a)	RSS-210 Issue 9 B.10	Pass
99% Bandwidth	N/A	RSS-Gen 6.6	Pass

### 2.4 Test System Details

The test samples were received on May 30, 2017. The FCC identifiers for all applicable equipment, plus descriptions of all cables used in the tested system, are identified in the following table.

**Table 2-3: Equipment Under Test**

Part	Manufacturer	Model	Serial Number	FCC ID	Cable Description	RTL Bar Code
Transceiver	Alarm.com	ADC-470L	13458953	YL6-143470L	N/A	22203
Transceiver	Alarm.com	ADC-470L	ADC-SEM-100	YL6-143470L	N/A	22525
12 VDC/AC Adapter	HON-KWANG	D12-50	N/A	N/A	1.8m unshielded	16120

## 2.5 Configuration of Tested System

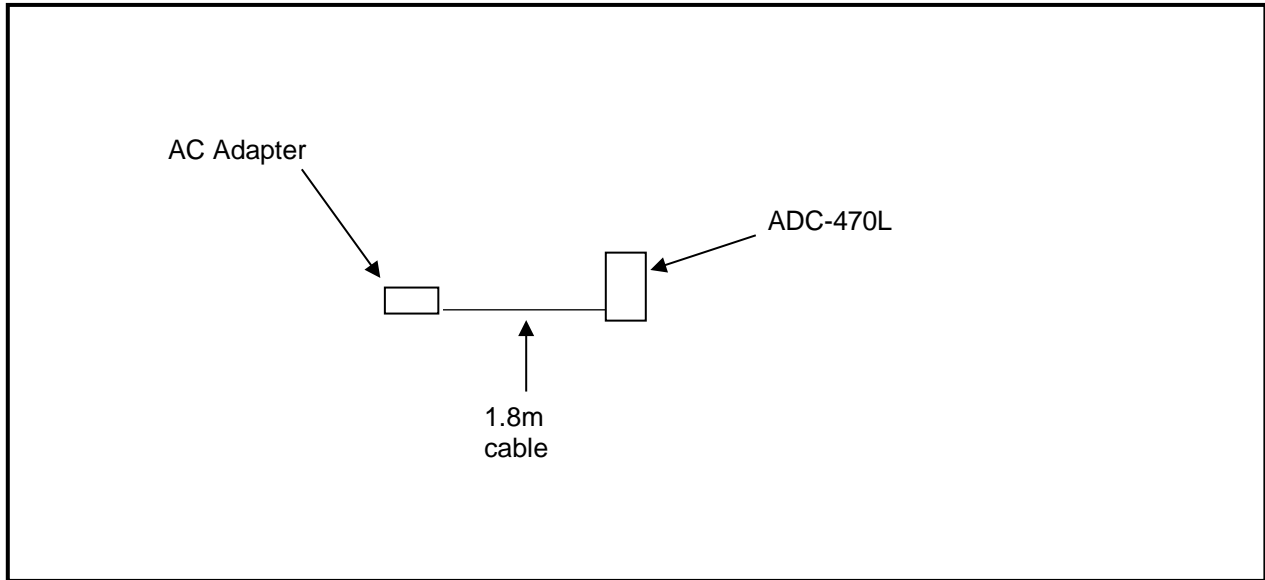

**Figure 2-1: Configuration of System Under Test**

### 3 Radiated Emissions – FCC 15.209, 15.249(a); RSS-210 B.10; RSS-Gen

#### 3.1 Limits of Radiated Emissions Measurement

Frequency (MHz)	Field Strength (uV/m)	Measurement Distance (m)
0.009-0.490	2400/f (kHz)	300
0.490-1.705	2400/f (kHz)	30
1.705-30.0	30	30
30-88	100	3
88-216	150	3
216-960	200	3
Above 960	500	3

As shown in 15.35(b), for frequencies above 1000 MHz, the field strength limits are based on average detector, however, the peak field strength of any emission shall not exceed the maximum permitted average limits specified above by more than 20 dB under any circumstances of modulation.

##### 3.1.1 Radiated Emissions Measurement Test Procedure

Before final measurements of radiated emissions were made on the open-field three/ten meter range, the EUT was scanned indoors at one and three meter distances. This was done in order to determine its emissions spectrum signature. The physical arrangement of the test system and associated cabling was varied in order to determine the effect on the EUT's emissions in amplitude, direction and frequency. This process was repeated during final radiated emissions measurements on the open-field range, at each frequency, in order to ensure that maximum emission amplitudes were attained.

Final radiated emissions measurements were made on the three/ten-meter, open-field test site. The EUT was placed on a nonconductive turntable 0.8 m (< 1 GHz) / 1.5 m (> 1 GHz) above the ground plane. The spectrum was examined from 9 kHz to the 10<sup>th</sup> harmonic of the highest fundamental transmitter frequency (9.16 GHz).

At each frequency, the EUT was rotated 360°, and the antenna was raised and lowered from 1 to 4 meters in order to determine the emission's maximum level. Measurements were taken using both horizontal and vertical antenna polarizations. For frequencies between 30 and 1000 MHz, the spectrum analyzer's 6 dB bandwidth was set to 120 kHz, and the analyzer was operated in the CISPR quasi-peak detection mode. For emissions above 1000 MHz, emissions are measured using the average detector function with a minimum resolution bandwidth of 1 MHz. No video filter less than 10 times the resolution bandwidth was used. The highest emission amplitudes relative to the appropriate limit were measured and recorded in this report.

**Table 3-1: Radiated Emissions Test Equipment**

RTL Asset #	Manufacturer	Model	Part Type	Serial Number	Calibration Due Date
900791	Chase	CBL6112	Antenna (30 MHz – 2 GHz)	2099	6/11/18
900772	EMCO	3161-02	Horn Antenna (2 - 4 GHz)	9804-1044	4/9/18
900321	EMCO	3161-03	Horn Antenna (4 - 8.2 GHz)	9528-1020	4/9/18
900323	EMCO	3160-07	Horn Antenna (8.2 - 12.4 GHz)	9605-1024	4/9/18
901581	Rohde & Schwarz	FSU	Spectrum Analyzer	1166.1660.50	3/22/18
901592	Insulated Wire Inc.	KPS-1503-3600-KPR	SMK RF Cables 20'	NA	8/3/17

**3.2 Radiated Emissions Test Results**

**Table 3-2: Radiated Emissions Test Data – Quasi-Peak**

Emission Frequency (MHz)	Quasi-Peak Detector Level (dBuV/m) (1 MHz RBW/10 Hz VBW)	Site Correction Factor (dB/m)	Quasi-Peak Corrected (dBuV/m)	Quasi-Peak Limit (dBuV/m)	Margin (dB)
916	91.6	1.6	93.2	94.0	-0.8

\* testing performed at 3m

**3.3 Radiated Emissions Harmonics/Spurious Test Data**

**Table 3-3: Radiated Emissions Harmonics/Spurious – 916 MHz; Peak**

Emission Frequency (MHz)	Peak Detector (dBuV/m) (1 MHz RBW/ 3 MHz VBW)	Site Correction Factor (dB/m)	Peak Corrected (dBuV/m)	Peak Limit (dBuV/m)	Peak Margin (dB)
1832	4.3	30.7	35.0	74.0	-39.0
2748	15.5	25.8	41.3	74.0	-32.7
3664	1.9	27.6	29.5	74.0	-44.5
4580	3.1	33.5	36.6	74.0	-37.4
5496	2.4	33.9	36.3	74.0	-37.7
6412	2.6	34.9	37.5	74.0	-36.5
7328	3.1	35.7	38.8	74.0	-35.2
8244	3.3	41.7	45.0	74.0	-29.0
9160	3.9	42.0	45.9	74.0	-28.1



**Table 3-4: Radiated Emissions Harmonics/Spurious – 916 MHz; Average**

Emission Frequency (MHz)	Average Detector (dBuV/m) (1 MHz RBW/ 3 MHz VBW)	Site Correction Factor (dB/m)	Average Corrected (dBuV/m)	Average Limit (dBuV/m)	Average Margin (dB)
1832	-3.0	30.7	27.7	54.0	-26.3
2748	13.0	25.8	38.8	54.0	-15.2
3664	-6.2	27.6	21.4	54.0	-32.6
4580	-5.6	33.5	27.9	54.0	-26.1
5496	-6.5	33.9	27.4	54.0	-26.6
6412	-5.5	34.9	29.4	54.0	-24.6
7328	-5.7	35.7	30.0	54.0	-24.0
8244	-4.6	41.7	37.1	54.0	-16.9
9160	-5.1	42.0	36.9	54.0	-17.1

\* testing performed at 3m

Measurement uncertainty: Measurement uncertainties shown for these tests are expanded uncertainties expressed at 95% confidence level using a coverage factor k = 2. +4.0 dB / -2.65 dB

**Test Personnel:**

Daniel W. Baltzell Test Engineer	 Signature	June 16, 2017 Date of Test
-------------------------------------	---	-------------------------------

#### 4 AC Conducted Emissions - FCC 15.207; RSS-Gen 8.8: Conducted Limits

##### 4.1 Site and Test Description

The power line conducted emissions measurements were performed in a Series 81 type shielded enclosure manufactured by Rayproof. The EUT was assembled on a wooden table 80 centimeters high. Power was fed to the EUT through a 50-ohm/50 microhenry Line Impedance Stabilization Network (LISN). The EUT LISN was fed power through an A.C. filter box on the outside of the shielded enclosure. The filter box and EUT LISN housing are bonded to the ground plane of the shielded enclosure. A second LISN, the peripheral LISN, provides isolation for the EUT test peripherals. This peripheral LISN was also fed A.C. power. A metal power outlet box, which is bonded to the ground plane and electrically connected to the peripheral LISN, powers the EUT host peripherals.

The spectrum analyzer was connected to the AC line through an isolation transformer. The 50-ohm output of the EUT LISN was connected to the spectrum analyzer input through a Solar 100 kHz high-pass filter. The filter is used to prevent overload of the spectrum analyzer from noise below 100 kHz. Conducted emission levels were measured on each current-carrying line with the spectrum analyzer operating in the CISPR quasi-peak mode (or peak mode if applicable).

The analyzer's 6 dB bandwidth was set to 9 kHz. Video filter less than 10 times the resolution bandwidth is not used. Average measurements are performed in linear mode using a 10 kHz resolution bandwidth, a 1 Hz video bandwidth, and by increasing the sweep time in order to obtain a calibrated measurement. The emission spectrum was scanned from 150 kHz to 30 MHz. The highest emission amplitudes relative to the appropriate limits were measured and have been recorded.

##### 4.2 Test Limits

Line-Conducted Emissions		
Limit (dBµV)		
Frequency (MHz)	Quasi-Peak	Average
0.15 to 0.50	66 to 56	56 to 46
0.50 to 5.00	56	46
5.00 to 30.00	60	50

Table 4-1: Conducted Emissions Test Equipment

RTL Asset #	Manufacturer	Model	Part Type	Serial Number	Calibration Due Date
900339	Hewlett Packard	85650A	Quasi-Peak Adapter	2521A00743	3/8/18
900930	Hewlett Packard	85662A	Spectrum Analyzer Display Section	3144A20839	4/26/19
900931	Hewlett Packard	8566B	Spectrum Analyzer (100 Hz - 22 GHz)	3138A07771	4/26/19
901083	AFJ International	LS16/110VAC	16A LISN	16010020080	4/18/18
N/A	Quantum Change	Tile!	Test Software	4.0.A.8	N/A

### 4.3 Conducted Emissions Test Data

Plot 4-1: Conducted Emissions Transmit - +3.9VDC

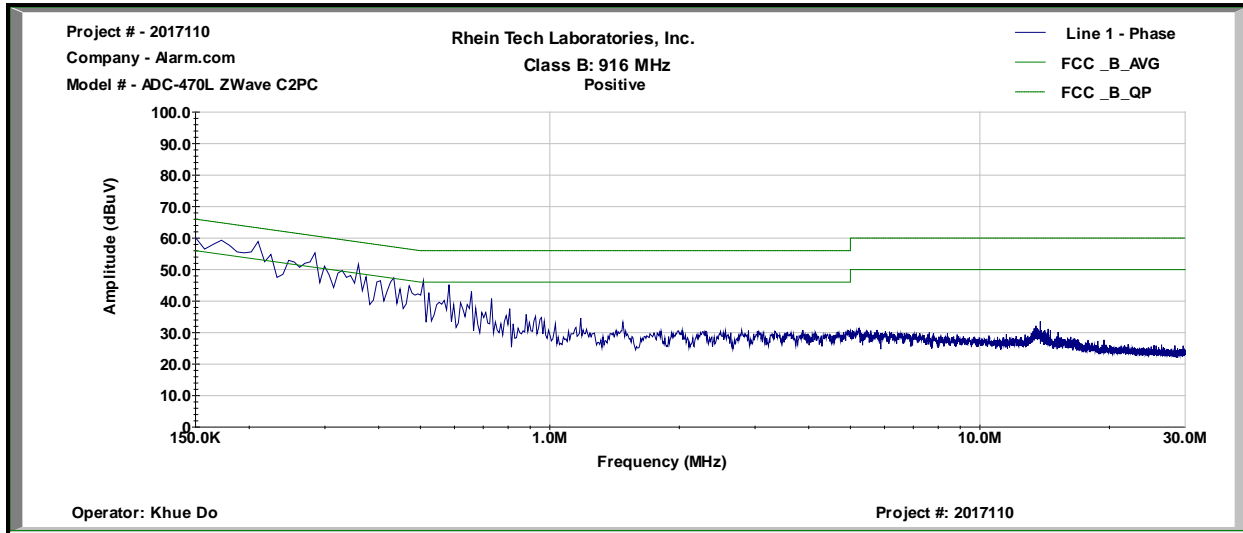
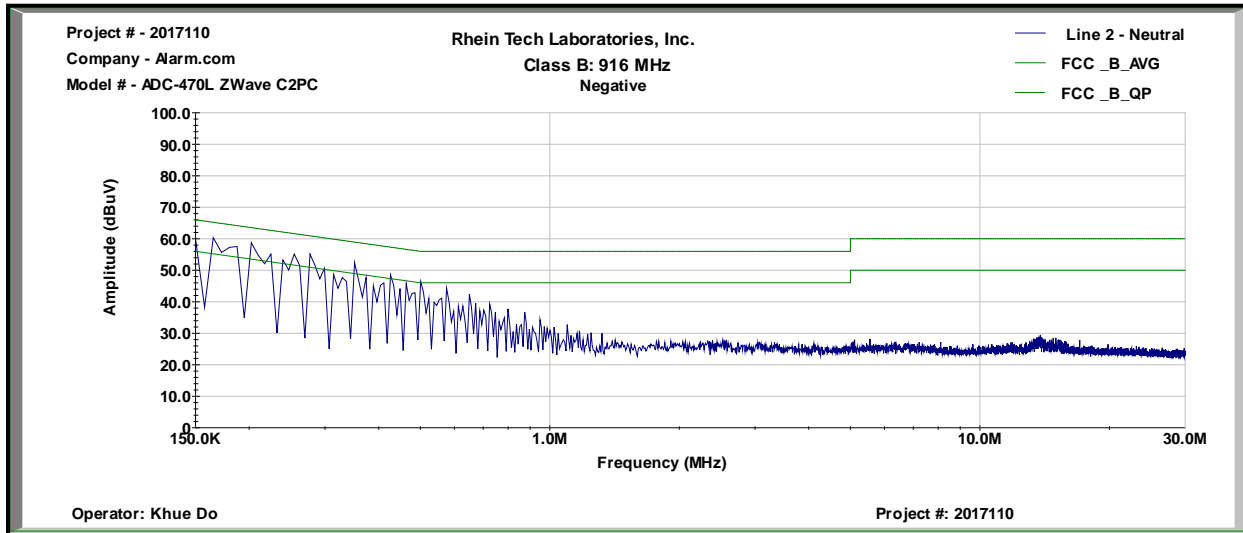

Table 4-2: Conducted Emissions Positive Level Check

Frequency (MHz)	Detector	Level (dB $\mu$ V/m)	Limit (dB $\mu$ V)	Margin (dB)	Performance
0.150	QPK	54.3	66	-11.7	PASS
	AVG	27.6	56	-28.4	PASS
0.210	QPK	48.2	64.3	-16.1	PASS
	AVG	22.4	54.3	-31.9	PASS
0.285	QPK	42.0	62.1	-20.1	PASS
	AVG	16.1	52.1	-36.0	PASS
0.360	QPK	41.6	60	-18.4	PASS
	AVG	11.0	50	-39.0	PASS
0.540	QPK	32.6	56	-23.4	PASS
	AVG	13.4	46	-32.6	PASS

**Plot 4-2: Conducted Emissions Transmit – VDC Return**



**Table 4-3: Conducted Emissions Negative Level Check**

Frequency (MHz)	Detector	Level (dB $\mu$ V/m)	Limit (dB $\mu$ V)	Margin (dB)	Performance
0.150	QPK	53.2	66	-12.8	PASS
	AVG	27.5	56	-28.5	PASS
0.210	QPK	46.8	64.3	-17.5	PASS
	AVG	22.8	54.3	-31.5	PASS
0.285	QPK	45.8	62.1	-16.3	PASS
	AVG	16.4	52.1	-35.7	PASS
0.360	QPK	36.8	60	-23.2	PASS
	AVG	16.2	50	-33.8	PASS
0.540	QPK	28.3	56	-27.7	PASS
	AVG	13.3	46	-32.7	PASS

Measurement uncertainty: Measurement uncertainties shown for these tests are expanded uncertainties expressed at 95% confidence level using a coverage factor  $k = 2$ .  $\pm 3.6$  dB

**Test Personnel:**

Khue N. Do Test Engineer	 Signature	May 22, 2017 Date of Test
-----------------------------	--	------------------------------

**5 99% Bandwidth – IC RSS-Gen 6.6**

**5.1 99% Bandwidth Test Procedure**

The 99% bandwidth per RSS-Gen was measured using a 50-ohm spectrum analyzer, per C63.10 6.9.2. The modulated carrier was adjusted on the analyzer with the RBW 1-5% of the occupied bandwidth and the span 1-5 times the occupied bandwidth. The sweep time was auto and allowed through several sweeps with the max hold function used in peak detector mode. The table below contains the bandwidth measurement results.

**Table 5-1: 99% Bandwidth Test Equipment**

RTL Asset #	Manufacturer	Model	Part Type	Serial Number	Calibration Due Date
901583	Agilent Technologies	EXA N9010A	Spectrum Analyzer (10 Hz – 26.5 GHz)	ATO-7568 SER MY51250846	4/21/18

**5.2 99% Bandwidth Test Data**

**Table 5-2: 99% Bandwidth Test Data**

99% bandwidths	
Frequency (MHz)	Bandwidth (kHz)
916	110.6

### 5.3 99% Bandwidth Plots

Plot 5-1: 99% Bandwidth; 916 MHz

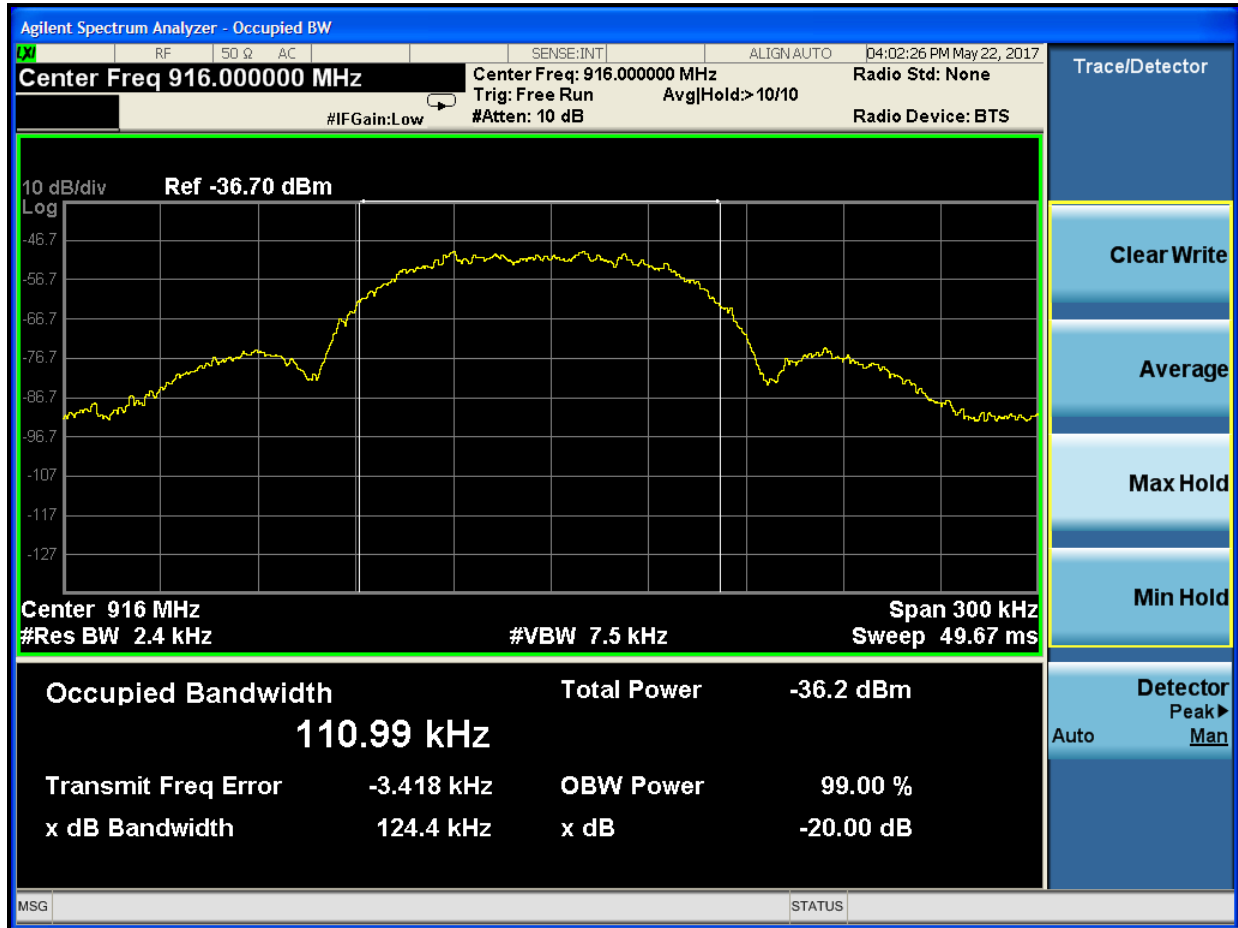

### Test Personnel:

Khue N. Do Test Engineer	 Signature	May 22, 2017 Date of Test
-----------------------------	---------------	------------------------------

### 6 Conclusion

The data in this measurement report shows that the EUT as tested, Alarm.com Model: ADC-470L, FCC ID: YL6-143470L, IC: 9111A-143470L, complies with the applicable requirements of Parts 2 and 15 of the FCC Rules and Regulations, and IC RSS-210 and RSS-Gen.