

# H3-EM-99-521 Electronic Swinghandle Operating Instructions

## Package Contents

- H3-EM-99-521 Electronic Swinghandle with RFID Reader (qty1)
- EM-0-45827 M3x25 POZIDRIV® Mounting Screws (qty 4)
- EM-0-47151 M3x14 POZIDRIV® Mounting Screw (qty 1)
- H3-EM-0-61927 Rotation Limiter (qty 1)
- E5-C-04 Pawl Screw (qty 1)
- EM-0-45826 Top Mounting Bracket (qty 1)
- EM-0-45822 Bottom Mounting Bracket (qty 1)
- Operating Instructions (qty 1)

## H3-EM-99-521 Electronic Swinghandle with RFID Reader

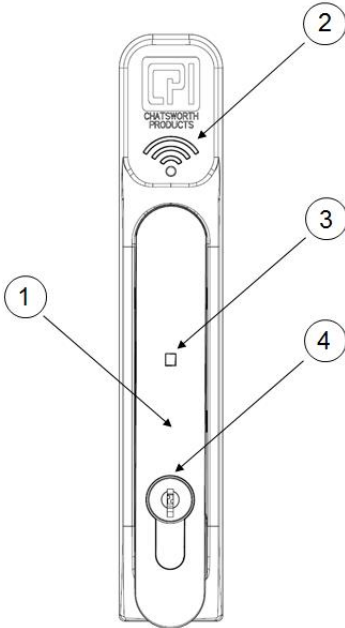

1. Handle
2. RFID Reader
3. Tri-Color Status LED
4. Lock Plug

## Features

- Installed 13.56MHz / 125kHz RFID reader module with Wiegand data output
- Compatible with 13.56MHz RFID cards with 4, 7, or 8byte Unique Identifiers (UID) and 125kHz prox cards
- Remote lock and unlock capability
- Single or multi-point lock actuation
- Momentary or continuous lock actuation
- Tri-color LED (blue/magenta/red) to indicate lock and handle status
- Manual lock override
- Accommodates both left and right doors
- For indoor use only

## Specifications

### Actuator Module

Supply Voltage ( $V_{SUPPLY}$ ):	5VDC
Standby Current:	25mA maximum at 5VDC
Operating Current:	150mA maximum at 5VDC (with no external mechanical load applied to handle)
Stall Current:	650mA maximum (at 5VDC, limited to 2 sec)
Operating Transit Time:	1 second maximum ( <b>NOTE:</b> Power must be present during transit times. If power is removed while the lock slide is in transit, it will complete it's cycle when power is restored.)
Electronic Unlock Time:	3 seconds minimum
Open Collector Outputs:	Rated for $V_{SUPPLY}$ , 100mA maximum load

### RFID Reader Module

Supply Voltage ( $V_{CC}$ ):	5VDC ( $\pm 10\%$ )
Operating Current:	125mA maximum (no external devices attached)
Transmit Frequency:	13.56MHz / 125kHz
DATA Signal Voltage:	5VDC
DATA Pulse Interval Time:	40 $\mu$ s
DATA Signal Delay:	2ms
Output Format:	Reverse Byte Order (13.56MHz cards) Most Significant Bit First (125kHz cards) Upper and Lower Parity Bits Included

## Mounting and Installation

Please refer to Southco trade drawing J-H3-EM-99-521 for mounting and installation details.

**⚠ NOTE:** Use a #1 POZIDRIV® driver when installing the mounting screws. See Southco trade drawing J-H3-EM-99-521 for additional details.

## Wiring Diagrams

The H3-EM-99-521 contains two separate functional modules: the actuator module and RFID reader module. The actuator module controls and monitors the locking function of the swinghandle. The RFID module reads the contents of a compatible RFID card and converts it to Wiegand format.

These two modules operate independently of each other and require connection to an access control unit (**not provided**), as illustrated below, for the entire product to be fully functional.

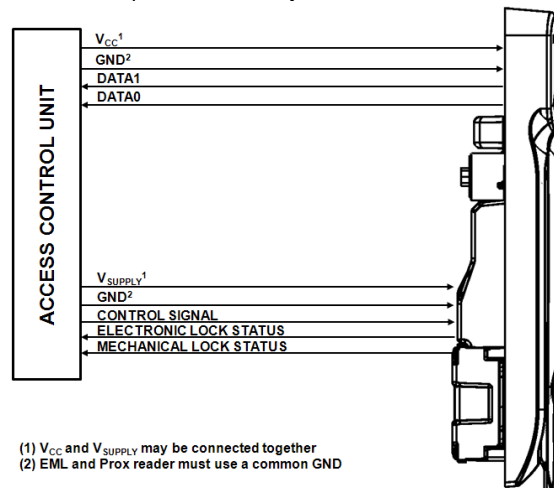

- (1)  $V_{CC}$  and  $V_{SUPPLY}$  may be connected together  
(2) EML and Prox reader must use a common GND

# H3-EM-99-521 Electronic Swinghandle Operating Instructions

The actuator module of the swinghandle is accessed with a six-position connector on the rear of the unit, shown below.

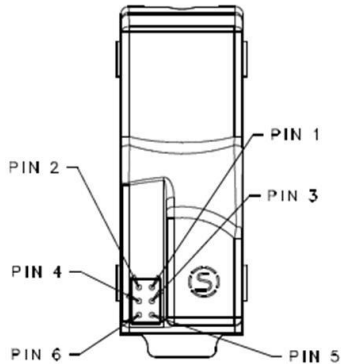

Pin	Description	Note
1	V <sub>GND</sub>	ground (must be same as RFID reader module)
2	V <sub>SUPPLY</sub>	5VDC power supply input (may be connected to RFID reader V <sub>CC</sub> input)
3	N/C	no connect
4	Control Signal	command input (5VDC, 100 milliseconds minimum)
5	Electronic Lock Status	open collector output (rated for V <sub>SUPPLY</sub> , 100mA max. load)
6	Mechanical Lock Status	open collector output (rated for V <sub>SUPPLY</sub> , 100mA max. load)

The RFID reader module of the swinghandle is accessed with a four-position connector attached to a harness connected to the module's circuit board. The module's connector pinout is:

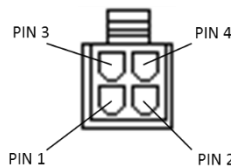

Pin	Wire Color	Description	Note
1	Black	GND	ground (must be same as actuator module)
2	Red	VCC	5VDC power supply input (may be connected to EML V <sub>SUPPLY</sub> input)
3	Green	DATA0	DATA0 output
4	White	DATA1	DATA1 output

**NOTE:** The mating connectors/harnesses are not provided with the H3-EM-99-521. Refer to Southco trade drawing J-H3-EM-99-521 for mating connector/harness requirements.

## Wiegand Data Output

### 125kHz Prox Cards

The RFID module will read the site and user codes from a compatible prox card, and convert to Wiegand data format, including upper even parity (Pe) and lower odd parity (Po) bits, as shown below.



### 13.56MHz RFID Cards

The RFID module will read the 4, 7, or 8 byte UID from a compatible RFID card, and convert to Wiegand data format in reverse byte order, including upper even parity (Pe) and lower odd parity (Po) bits, as shown below.

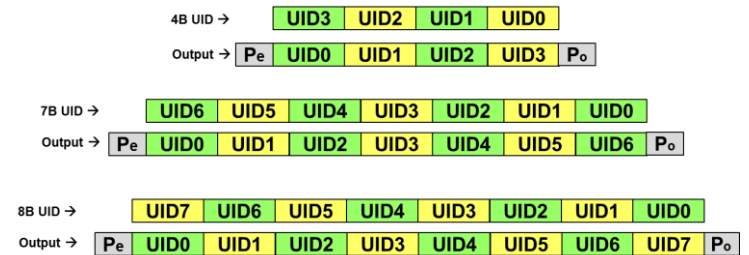

## Control Input Signal

This signal is used to control the electronic lock slide position.

- for UNLOCKED position: Supply 5VDC for at least 100 milliseconds. The lock will remain unlocked for as long as the signal is present, or a minimum of 3 seconds. Signal timing can typically be adjusted at the access control device. The control signal current draw is less than 10mA.
- for LOCKED position: Supply an open contact or 0VDC (0 to 0.5V)

## Electronic Lock Status Output and Mechanical Lock Status Output Signals

### Electronic Lock Status Output Signal

This output will be LOW (GND) when the lock slide is electromechanically moved to the unlocked position. It will be in the open collector state (high-impedance) when in the locked position.

### Mechanical Lock Status Output Signal

This output will be LOW (GND) when the handle is in the open position or when the keylock in the actuator is manually unlocked. It will be in the open collector state (high-impedance) when in the secured position.

**NOTE:** These outputs are open collector outputs rated for V<sub>SUPPLY</sub> with a maximum load of 100mA. To avoid damage to the H3-EM, do not exceed voltage and current ratings.

# H3-EM-99-521 Electronic Swinghandle Operating Instructions

## Status LED and Output Signals

The latch is equipped with a tri-color (blue/magenta/red) LED visible from the front of the latch. This LED provides a visible notification of the latch status. The different latch states are described below. Please refer to the **Control Input Signal**, **Electronic Lock Status Output Signal**, and **Mechanical Lock Status Output Signal** sections for further details on these signals.

### Secured

The latch is securely closed, prohibiting access.

- The Status LED will be solid blue.
- The electronic lock status output is at its open collector state.
- The mechanical lock status output is at its open collector state.

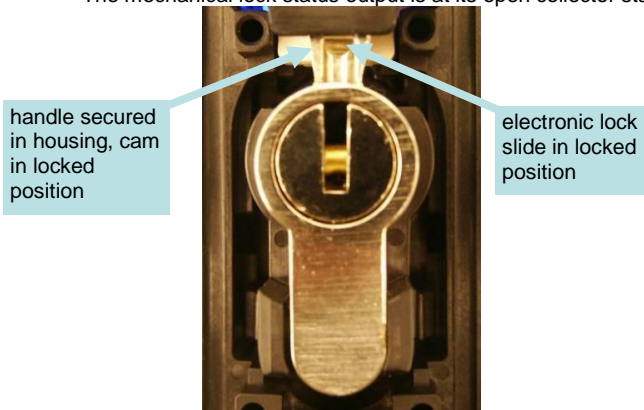

“Secured” State

### Mechanically Released

The latch is released by opening the handle or moving the cam from its lock position.

- The Status LED will flash blue.
- The electronic lock status output will be at its open collector state if the electronic lock slide is in the locked position. It will be 0V if the lock slide is in the unlocked position.
- The mechanical lock status output is 0V.

**⚠ NOTE:** The lock sensor is an optical device that senses the presence of the lock pawl. Reflectivity of the lock pawl material can affect sensing. Use only Southco-supplied locks.

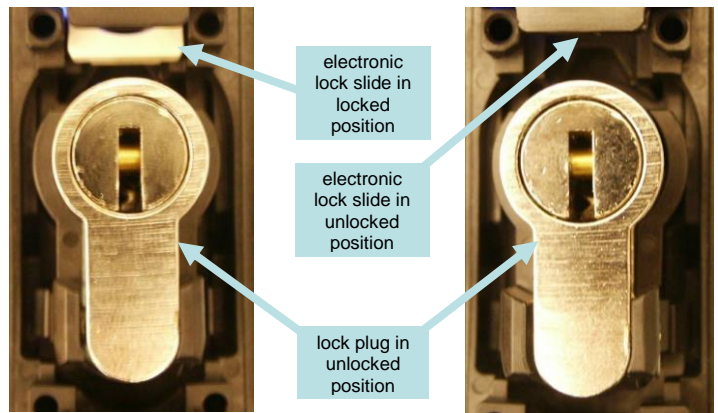

“Mechanically Released” State

### Electronically Released

The electronic lock slide is in the unlocked position and the handle can be pulled open.

- The Status LED will alternate flashing blue/magenta.
- The electronic lock status output is 0V while the lock slide is in the unlocked position.
- The mechanical lock status output is at its open collector state.

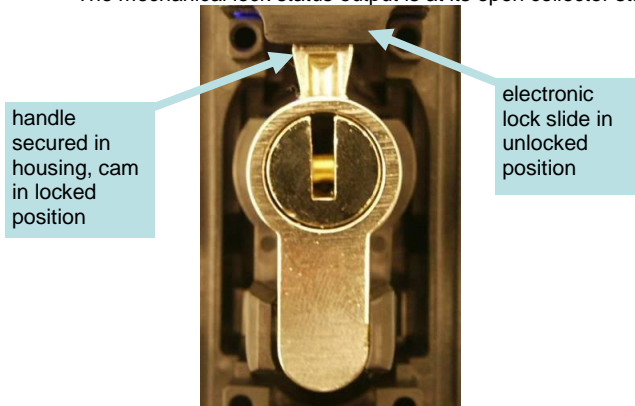

“Electronically Released” State

### Handle not Fully Closed

This is an interim state and may occur while closing the handle when the cam is not secured by the electronic lock slide. The latch is not fully secured during this state.

- The Status LED will alternate flashing blue/red if the cam is not detected. It will flash blue/red/red if the cam is detected, but the lock plate is not in the right position. This could be due to mechanical failure or tampering.
- The electronic lock status output is 0V if the lock slide is in the unlocked position. It will be at its open collector state if it is in the lock position.
- The mechanical lock status output is 0V if the cam is not detected. It will be at its open collector state if it is detected.

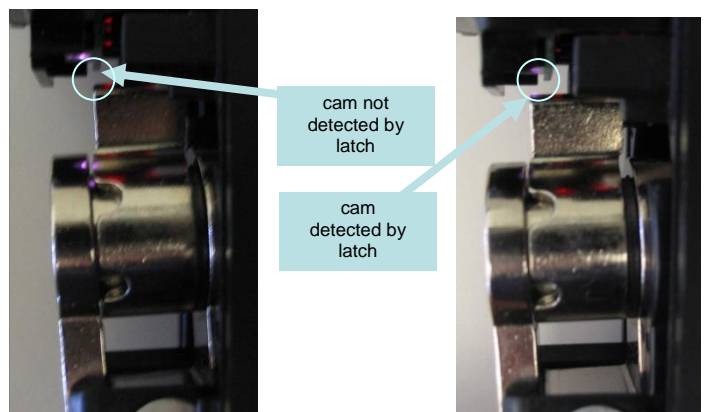

“Handle not Fully Closed” State

## Electronic Lock Slide Error

The electronic lock slide does not respond to the command input signal.

- The Status LED will flash magenta if the latch is secured. It will alternate flashing red/magenta if the latch is mechanically released.
- The electronic lock status output is at its open collector state.
- The mechanical lock status output will be at its open collector state if the cam is in its lock position. It will be 0V if the mechanical key is moved from its lock position.

## Error Input Command Sequence

The H3-EM can accept an input command from an external controller to flash the status LED red three times. This feature can be used to indicate that an error event has occurred (e.g. unauthorized access attempt).

The control input signal needs to meet the timing requirements shown below to flash the status LED red.

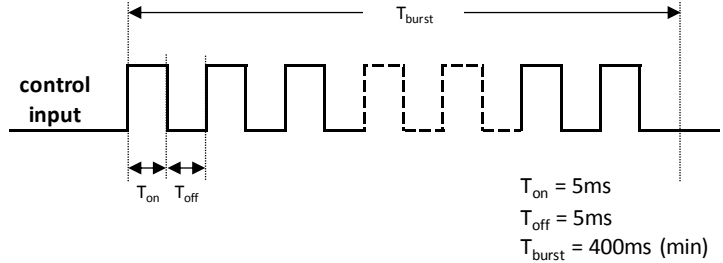

POZIDRIV® is a registered trademark of the Phillips Screw Company

## FCC Compliance Statement

This device complies with Part 15 of the FCC Rules. Operation is subject to the following two conditions:

- 1) This device may not cause harmful interference, and
- 2) This device must accept any interference received, including interference that may cause undesired operation.

This equipment has been tested and found to comply with the limits for a Class B digital device, pursuant to Part 15 of the FCC Rules. These limits are designed to provide reasonable protection against harmful interference in a residential installation.

This equipment generates, uses and can radiate radio frequency energy and, if not installed and used in accordance with the instructions, may cause harmful interference to radio communications. However, there is no guarantee that interference will not occur in a particular installation. If this equipment does cause harmful interference to radio or television reception, which can be determined by turning the equipment off and on, the user is encouraged to try to correct the interference by one of the following measures:

- Reorient or relocate the receiving antenna.
- Increase the separation between the equipment and receiver.
- Connect the equipment into an outlet on a circuit different from that to which the receiver is connected.
- Consult the dealer or an experienced radio/TV technician for help.

FCC Caution: To assure continued compliance, any changes or modifications not expressly approved by the party responsible for compliance could void the user's authority to operate this equipment.

