



SGS-CSTC Standards Technical Services (Shanghai) Co., Ltd.

588 West Jindu Road, Songjiang District, Shanghai, China
Telephone: +86 (0) 21 6191 5666
Fax: +86 (0) 21 6191 5678
ee.shanghai@sgs.com

Report No.: SHEM140700165802
Page: 1 of 85

1 Cover Page

RF TEST REPORT

Application No.:	SHEM1407001658RF
Applicant:	Audio Partnership PLC
FCC ID:	YKBMA201-014
IC:	9095A-MA201014
Equipment Under Test (EUT): NOTE: The following sample(s) submitted was/were identified on behalf of the client as	
Product Name:	Wireless Music System
Model No.(EUT):	Air 200 V2
Standards:	FCC PART 15 Subpart C: 2013 RSS-210 Issue 8 (December 2010) RSS-Gen Issue 3 (December 2010)
Date of Receipt:	July 07, 2014
Date of Test:	July 18, 2014 to August 11, 2014
Date of Issue:	August 13, 2014
Test Result:	Pass*

*In the configuration tested, the EUT detailed in this report complied with the standards specified above.



Tony Wu
E&E Section Manager
SGS-CSTC (Shanghai) Co., Ltd.



The manufacturer should ensure that all products in series production are in conformity with the product sample detailed in this report. If the product in this report is used in any configuration other than that detailed in the report, the manufacturer must ensure the new system complies with all relevant standards.

The report must not be used by the client to claim product certification, approval, or endorsement by NVLAP, NIST, or any agency of the federal government. All test results in this report can be traceable to National or International Standards.

This document is issued by the Company subject to its General Conditions of Service printed overleaf, available on request or accessible at www.sgs.com/terms_and_conditions.htm and, for electronic format documents, subject to Terms and Conditions for Electronic Documents at www.sgs.com/terms_e-document.htm. Attention is drawn to the limitation of liability, indemnification and jurisdiction issues defined therein. Any holder of this document is advised that information contained hereon reflects the Company's findings at the time of its intervention only and within the limits of Client's instructions, if any. The Company's sole responsibility is to its Client and this document does not exonerate parties to a transaction from exercising all their rights and obligations under the transaction documents. This document cannot be reproduced except in full, without prior written approval of the Company. Any unauthorized alteration, forgery or falsification of the content or appearance of this document is unlawful and offenders may be prosecuted to the fullest extent of the law. Unless otherwise stated the results shown in this test report refer only to the sample(s) tested and such sample(s) are retained for 90 days only.

2 Version

Revision Record				
Version	Chapter	Date	Modifier	Remark
00		August 13, 2014		Original

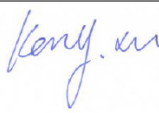
Authorized for issue by:			
Engineer		Eddy Zong _____ Print Name	
Clerk		Susie Liu _____ Print Name	
Reviewer		Keny Xu _____ Print Name	

3 Test Summary

Test Item	FCC Requirement	IC Requirement	Test method	Result
Antenna Requirement	FCC Part 15, Subpart C Section 15.203/15.247 (c)	RSS-Gen 7.1.2	---	PASS
AC Power Line Conducted Emission	FCC Part 15, Subpart C Section 15.207	RSS-Gen Issue 8 Clause 7.2.4	ANSI C63.10 (2009) Section 6.2	PASS
Minimum 6dB Bandwidth	FCC Part 15, Subpart C Section 15.247 (a)(2)	RSS-210 Issue 8 Annex 8	ANSI C63.10 (2009) Section 6.9.1	PASS
Conducted Peak Output Power	FCC Part 15, Subpart C Section 15.247 (b)(3)	RSS-210 Issue 8 Annex 8	ANSI C63.10 (2009) Section 6.10.2	PASS
Power Spectrum Density	FCC Part 15, Subpart C Section 15.247 (e)	RSS-210 Issue 8 Annex 8	ANSI C63.10 (2009) Section 6.11.2	PASS
RF Conducted Spurious Emissions and Band-edge	FCC Part 15, Subpart C Section 15.247(d)	RSS 210 A 8.5	ANSI C63.10 (2009) Section 7.7.9&7.7.10	PASS
Radiated Spurious Emissions and Band- edge	FCC Part 15, Subpart C Section 15.209&15.205	RSS-Gen section 4.9	ANSI C63.10 (2009) Section 6.5&6.6&6.7	PASS
99% Occupied bandwidth	---	RSS-Gen Issue 3 Clause 4.6.1	RSS-Gen Issue 3 Clause 4.6.1	PASS

4 Contents

	Page
1 COVER PAGE	1
2 VERSION	2
3 TEST SUMMARY	3
4 CONTENTS.....	4
5 GENERAL INFORMATION	5
5.1 CLIENT INFORMATION.....	5
5.2 GENERAL DESCRIPTION OF E.U.T.....	5
5.3 TECHNICAL SPECIFICATIONS.....	5
5.4 TEST MODE.....	5
5.5 DESCRIPTION OF SUPPORT UNITS.....	6
5.6 TEST LOCATION	6
5.7 TEST FACILITY	7
5.8 MEASUREMENT UNCERTAINTY	7
6 EQUIPMENTS USED DURING TEST.....	8
7 TEST RESULTS	9
7.1 E.U.T. TEST CONDITIONS	9
7.2 ANTENNA REQUIREMENT.....	10
7.3 CONDUCTED EMISSIONS ON MAINS TERMINALS	11
7.4 6dB OCCUPIED BANDWIDTH.....	15
7.5 CONDUCTED PEAK OUTPUT POWER	23
7.6 PEAK POWER SPECTRAL DENSITY.....	29
7.7 CONDUCTED SPURIOUS EMISSIONS AND BAND-EDGE	37
7.7.1 <i>Conducted spurious emission</i>	38
7.7.2 <i>Conducted Band-edge</i>	50
7.8 RADIATED SPURIOUS EMISSIONS AND BAND-EDGE.....	54
7.8.1 <i>Radiated Spurious Emissions:</i>	57
7.8.2 <i>Radiated Band edge</i>	64
7.9 99% OCCUPIED BANDWIDTH	78
8 TEST SETUP PHOTOGRAPHS.....	85
9 EUT CONSTRUCTIONAL DETAILS.....	85

5 General Information

5.1 Client Information

Applicant: Audio Partnership PLC
 Address of Applicant: Gallery Court, Hankey Place, London, SE1 4BB, UNITED KINGDOM
 Manufacturer: Audio Partnership PLC
 Address of Manufacturer: Gallery Court, Hankey Place, London, SE1 4BB, UNITED KINGDOM
 Factory: Hansong (Nanjing) Technology Ltd.
 Address of Factory: 8th Kangping Road, Jiangning Economy & Technology Development Zone, Nanjing, 211106, China.

5.2 General Description of E.U.T.

Product Description: Mobile product
 Brand Name: Cambridge Audio
 Power Supply: AC 100-120V/220-240V 50/60Hz
 Rated Max Power: 200W

5.3 Technical Specifications

Operation Frequency: 2412MHz-2462MHz
 Modulation Type: 802.11b: DSSS(CCK, DQPSK, DBPSK)
 802.11g: OFDM(64QAM, 16QAM, QPSK, BPSK)
 Number of Channel: 11 Channels
 Data Rate: 802.11b: 1Mbps, 5.5Mbps, 11Mbps,
 802.11g: 6Mbps, 9Mbps, 12Mbps, 18Mbps, 36Mbps, 48Mbps, 54Mbps
 Antenna Type: Integral
 Remark: the two PIFA antennas are not working simultaneously.
 Antenna Gain: 2.0 dBi

5.4 Test Mode

Test Mode	Description of Test Mode
Engineering mode	Using test software to control EUT working in continuous transmitting in max power level 8 (Range 8-15), and channel and modulation type.

Preliminary tests were performed in all tests in different data rate and antenna configurations at lowest channel, the data rates of worse case as below were chosen for final test.

Modulation Type	Channel	Frequency	Data rate
802.11 b	The lowest channel(CH1)	2412MHz	1Mbps
	The middle channel(CH6)	2437MHz	1Mbps
	The Highest channel(CH11)	2462MHz	1Mbps
802.11 g	The lowest channel(CH1)	2412MHz	6Mbps
	The middle channel(CH6)	2437MHz	6Mbps
	The Highest channel(CH11)	2462MHz	6Mbps

5.5 Description of Support Units

The EUT has been tested with support equipments as below.

Description	Manufacturer	Model No.	Supplied By
Laptop	Lenovo	ThinkPad X 100e	SGS
Serial port adapter plate	/	/	SGS

Software name	Manufacturer	Version	Supplied By
HyperTerminal	Microsoft	1.3.3.0881	SGS

Description of connection

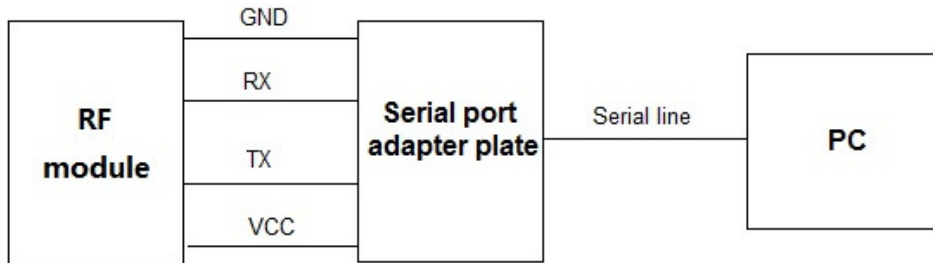

5.6 Test Location

All tests were performed at:

SGS-CSTC Standards Technical Services (Shanghai) Co., Ltd.

No.588 West Jindu Road, Songjiang District, Shanghai, China.201612.

Tel: +86 21 6191 5666

Fax: +86 21 6191 5678

5.7 Test Facility

The test facility is recognized, certified, or accredited by the following organizations:

- **CNAS (No. CNAS L0599)**

CNAS has accredited SGS-CSTC Standards Technical Services (Shanghai) Co., Ltd. to ISO/IEC 17025:2005 General Requirements for the Competence of Testing and Calibration Laboratories (CNAS-CL01 Accreditation Criteria for the Competence of Testing and Calibration Laboratories) for the competence in the field of testing. Date of expiry: 2017-07-14.

- **FCC – Registration No.: 402683**

SGS-CSTC Standards Technical Services (Shanghai) Co., Ltd. has been registered and fully described in a report filed with the Federal Communications Commission (FCC). The acceptance letter from the FCC is maintained in our files. Registration No.: 402683, Expiry Date: 2015-02-22.

- **Industry Canada (IC) – IC Assigned Code: 8617A**

The 3m Semi-anechoic chamber of SGS-CSTC Standards Technical Services (Shanghai) Co., Ltd. has been registered by Certification and Engineering Bureau of Industry Canada for radio equipment testing with Registration No.: 8617A-1. Expiry Date: 2017-06-18.

- **VCCI (Member No.: 3061)**

The 3m Semi-anechoic chamber and Shielded Room of SGS-CSTC Standards Technical Services (Shanghai) Co., Ltd. has been registered in accordance with the Regulations for Voluntary Control Measures with Registration No.: R-3868 and C-4336 respectively. Date of Registration: 2012-05-29. Date of Expiry: 2015-05-28.

5.8 Measurement Uncertainty

No.	Parameter	Measurement Uncertainty
1	Radio Frequency	$< \pm 1 \times 10^{-5}$
2	Total RF power, conducted	$< \pm 1.5$ dB
3	RF power density, conducted	$< \pm 3$ dB
4	Spurious emissions, conducted	$< \pm 3$ dB
5	All emissions, radiated	$< \pm 6$ dB (30MHz – 1GHz) $< \pm 6$ dB (above 1GHz)
6	Temperature	$< \pm 1^{\circ}\text{C}$
7	Humidity	$< \pm 5$ %
8	DC and low frequency voltages	$< \pm 3$ %

6 Equipments Used during Test

Item	Test Equipment	Manufacturer	Model No.	Serial No.	Cal. Date	Cal. Due date
1	EMI test receiver	Rohde & Schwarz	ESCS30	100086	2014-02-14	2015-02-13
2	Line impedance stabilization network	SCHWARZBECK	NSLK8127	8127-490	2014-02-14	2015-02-13
3	Line impedance stabilization network	ETS	3816/2	00034161	2014-02-14	2015-02-13
4	Spectrum Analyzer	Rohde & Schwarz	FSP-30	2705121009	2014-02-14	2015-02-13
5	EMI test receiver	Rohde & Schwarz	ESU40	100109	2014-02-14	2015-02-13
6	Active Loop Antenna (9kHz to 30MHz)	Rohde & Schwarz	FMZB 1519	1519-034	2014-03-19	2015-03-18
7	Broadband UHF-VHF ANTENNA (25MHz to 2GHz)	SCHWARZBECK	VULB9168	9168-313	2014-02-14	2015-02-13
8	Ultra broadband antenna (25MHz to 3GHz)	Rohde & Schwarz	HL562	100227	2013-10-09	2014-10-08
9	Horn Antenna (1GHz to 18GHz)	Rohde & Schwarz	HF906	100284	2014-02-14	2015-02-13
10	Horn Antenna (1GHz to 18GHz)	SCHWARZBECK	BBHA9120D	9120D-679	2014-07-28	2015-07-27
11	Horn Antenna (14GHz to 40GHz)	SCHWARZBECK	BBHA 9170	BBHA9170373	2014-02-14	2015-02-13
12	Pre-amplifier (9KHz – 2GHz)	LNA6900	TESEQ	71033	2014-02-14	2015-02-13
13	Pre-amplifier (1GHz – 26.5GHz)	Rohde & Schwarz	SCU-F0118-G40-BZ4-CSS(F)	10001	2014-02-14	2015-02-13
14	Pre-amplifier (14GHz – 40GHz)	Rohde & Schwarz	SCU-F1840-G35-BZ3-CSS(F)	10001	2014-02-14	2015-02-13
15	Tunable Notch Filter	Wainwright instruments GmbH	WRCT800.0/8 80.0-0.2/40-5SSK	9	2014-06-02	2015-06-01
16	High pass Filter	FSCW	HP 12/2800-5AA2	19A45-02	2014-06-02	2015-06-01
17	High-low temperature cabinet	Suzhou Zhihe	TL-40	50110050	2014-04-13	2015-04-12
18	AC power stabilizer	WOCEN	6100	51122	2014-06-02	2015-06-01
19	DC power	QJE	QJ30003SII	611145	2014-06-02	2015-06-01
20	Signal Generator (Interferer)	Agilent	SMR40	100555	2014-02-14	2015-02-13
21	Signal Generator (Blocker)	Rohde & Schwarz	SMJ100A	02.20.360.142	2014-02-14	2015-02-13
22	Splitter	Anritsu	MA1612A	M12265	/	/
23	Coupler	e-meca	803-S-1	900-M01	/	/

7 Test Results

7.1 E.U.T. test conditions

Test Power: AC 120V, 60Hz

Requirements: 15.31(e) For intentional radiators, measurements of the variation of the input power or the radiated signal level of the fundamental frequency component of the emission, as appropriate, shall be performed with the supply voltage varied between 85% and 115% of the nominal rated supply voltage. For battery operated equipment, the equipment tests shall be performed using a new battery.

Operating Environment:	Temperature:	20.0 -25.0 °C
	Humidity:	35-75 % RH
	Atmospheric Pressure:	99.2 -102 kPa

Test frequencies: According to the 15.31(m) Measurements on intentional radiators or receivers, other than TV broadcast receivers, shall be performed and, if required, reported for each band in which the device can be operated with the device operating at the number of frequencies in each band specified in the following table:

Frequency range over which device operates	Number of frequencies	Location in the range of operation
1 MHz or less	1	Middle
1 to 10 MHz	2	1 near top and 1 near bottom
More than 10 MHz	3	1 near top, 1 near middle and 1 near bottom

Pursuant to Part 15.31(c) For swept frequency equipment, measurements shall be made with the frequency sweep stopped at those frequencies chosen for the measurements to be reported.

Test frequency is the lowest channel: 1 channel (2412MHz), middle channel: 39 channel (2437MHz) and highest channel: 11 channel (2462MHz) with fixed at channel.

7.2 Antenna Requirement

Standard requirement:

15.203 requirement:

An intentional radiator shall be designed to ensure that no antenna other than that furnished by the responsible party shall be used with the device. The use of a permanently attached antenna or of an antenna that uses a unique coupling to the intentional radiator, the manufacturer may design the unit so that a broken antenna can be replaced by the user, but the use of a standard antenna jack or electrical connector is prohibited

15.247(b) (4) requirement:

The conducted output power limit specified in paragraph (b) of this section is based on the use of antennas with directional gains that do not exceed 6 dBi. Except as shown in paragraph (c) of this section, if transmitting antennas of directional gain greater than 6 dBi are used, the conducted output power from the intentional radiator shall be reduced below the stated values in paragraphs (b)(1), (b)(2), and (b)(3) of this section, as appropriate, by the amount in dB that the directional gain of the antenna exceeds 6 dBi.

EUT Antenna:

The antenna is Plug-in antenna. The gain of the antenna is less than 2.0 dBi.

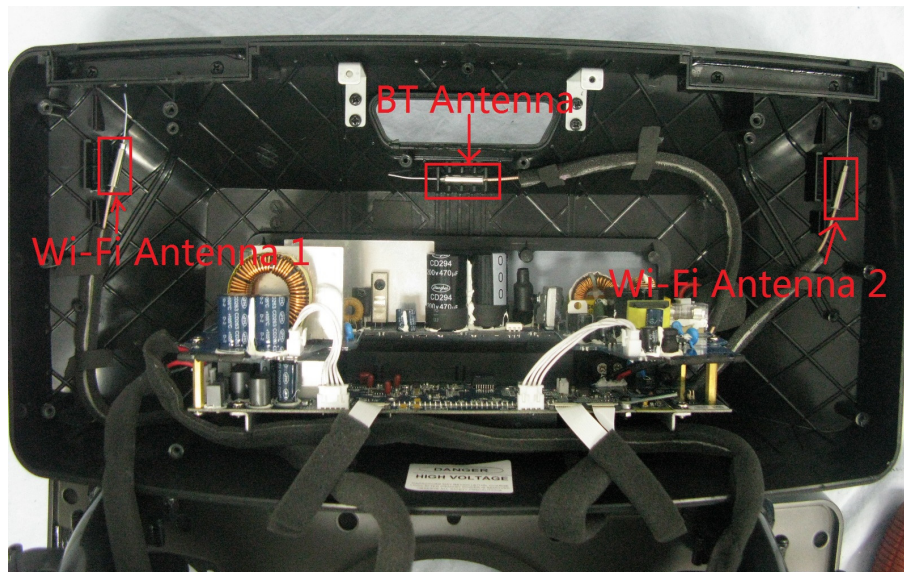

7.3 Conducted Emissions on Mains Terminals

Frequency Range: 150 KHz to 30 MHz

Class/Severity: Class B

Limit:

Frequency range MHz	Class B Limits: dB (µV)	
	Quasi-peak	Average
0.15 to 0.50	66 to 56	56 to 46
0.50 to 5	56	46
5 to 30	60	50

Note1: The limit decreases linearly with the logarithm of the frequency in the range 0.15 MHz to 0.50MHz.

Note2: The lower limit is applicable at the transition frequency.

Test site/setup:

Test instrumentation set-up:

Frequency Range	Detector	RBW	VBW
9KHz to 150Hz	Quasi-peak	200Hz	500Hz
150KHz to 30MHz	Quasi-peak	9kHz	30kHz

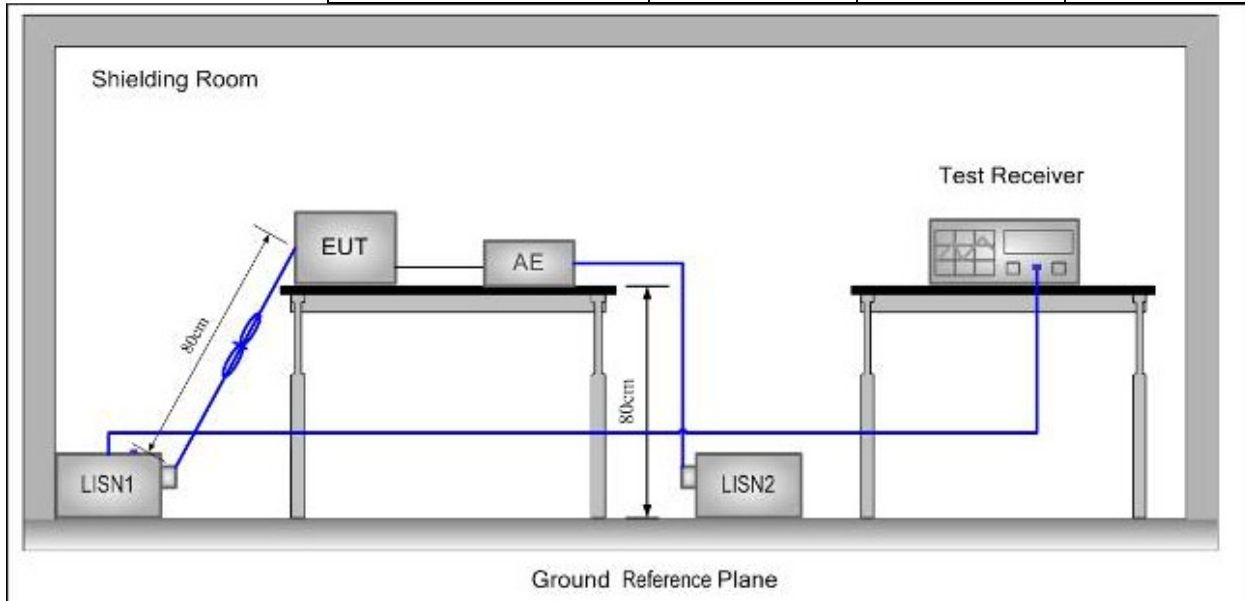

Test Procedure:

1. The mains terminal disturbance voltage was measured with the EUT in a shielded room.
2. The EUT was connected to AC power source through a LISN 1 (Line Impedance Stabilization Network) which provides 50Ω/50µH + 5Ω linear impedance. The power cables of all other units of the EUT were connected to a second LISN, which was bonded to the ground reference plane in the same way as the LISN for the unit being measured. A multiple socket outlet strip was used to connect multiple power cables to a single LISN provided the rating of the LISN was not exceeded
3. The tabletop EUT was placed upon a non-metallic table 0.8m above the ground reference plane.

And for floor-standing arrangement, the EUT was placed on the horizontal ground reference plane, but separated from metallic contact with the ground reference plane by 0.1m of insulation.

4. The test was performed with a vertical ground reference plane. The rear of the EUT shall be 0.4 m from the vertical ground reference plane. The vertical ground reference plane was bonded to the horizontal ground reference plane. The LISN was placed 0.8 m from the boundary of the unit under test and bonded to a ground reference plane for LISN mounted on top of the ground reference plane. This distance was between the closest points of the LISN and the EUT. The mains lead of EUT excess 0.8m was folded back and forth parallel to the lead so as to form a horizontal bundle with a length between 0.3m and 0.4m. All other units of the EUT and associated equipment were at least 0.8 m from the LISN.

Remark: Pre-scan was performed with peak detected on all ports, Quasi-peak & average measurements were performed at the frequencies at which maximum peak emission level were detected. Pretest under all modes; choose the worst case mode (802.11b in Middle channel) record on the report. Please see the attached Quasi-peak and Average test results.

Test Result: Pass



Test Data:

Test Mode:	802.11b	Test Channel:	Middle
Test Port:	AC Live Line		

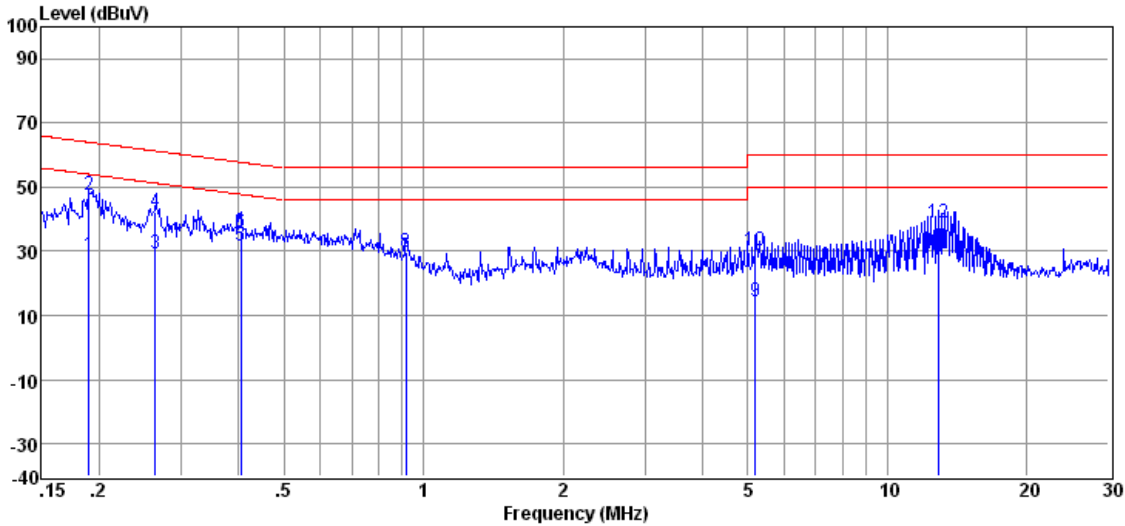

Item	Freq.	Read Level	LISN Factor	Cable Loss	Level	Limit Line	Over Limit	Detector
(Mark)	(MHz)	(dB μ V)	(dB)	(dB)	(dB μ V)	(dB μ V)	(dB)	
1	0.190	19.16	0.27	0.10	28.74	54.02	-25.28	Average
2	0.190	38.00	0.27	0.10	47.58	64.02	-16.44	QP
3	0.264	19.89	0.26	0.10	29.23	51.29	-22.06	Average
4	0.264	32.81	0.26	0.10	42.15	61.29	-19.14	QP
5	0.404	21.14	0.25	0.10	31.53	47.77	-16.24	Average
6	0.404	25.62	0.25	0.10	36.01	57.77	-21.76	QP
7	0.918	19.20	0.18	0.10	28.26	46.00	-17.74	Average
8	0.918	20.83	0.18	0.10	29.89	56.00	-26.11	QP
9	5.194	5.92	0.39	0.20	14.31	50.00	-35.69	Average
10	5.194	21.69	0.39	0.20	30.08	60.00	-29.92	QP
11	12.852	20.97	0.35	0.10	29.51	50.00	-20.49	Average
12	12.852	30.52	0.35	0.10	39.06	60.00	-20.94	QP

Test Port: AC Neutral Line

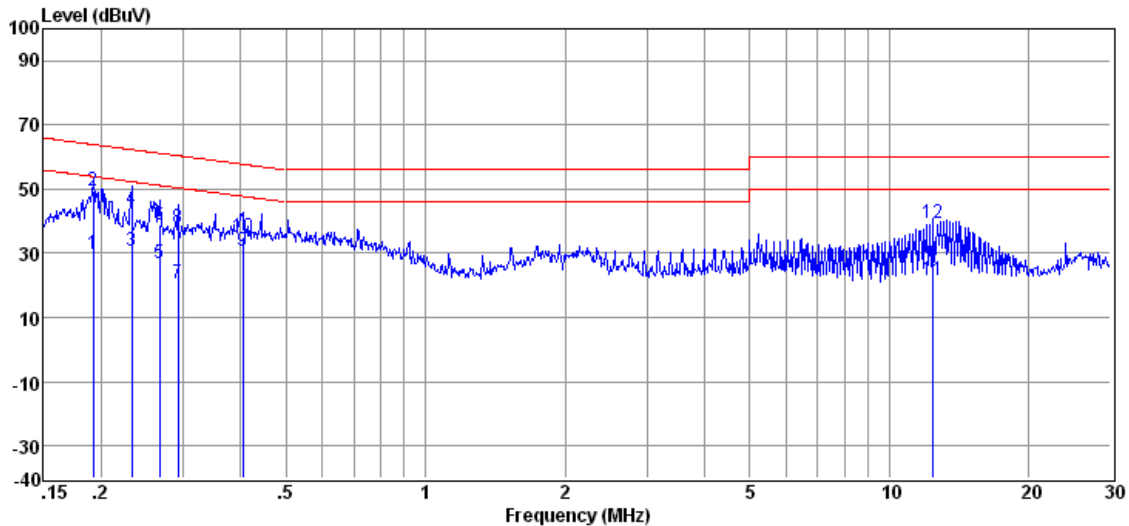

Item	Freq.	Read Level	LISN Factor	Cable Loss	Level	Limit Line	Over Limit	Detector
(Mark)	(MHz)	(dBμV)	(dB)	(dB)	(dBμV)	(dBμV)	(dB)	
1	0.192	20.29	0.30	0.10	29.93	53.93	-24.00	Average
2	0.192	40.00	0.30	0.10	49.64	63.93	-14.29	QP
3	0.233	21.09	0.29	0.10	30.64	52.35	-21.71	Average
4	0.233	34.00	0.29	0.10	43.55	62.35	-18.80	QP
5	0.267	17.65	0.29	0.10	26.99	51.20	-24.21	Average
6	0.267	29.73	0.29	0.10	39.07	61.20	-22.13	QP
7	0.292	11.49	0.29	0.10	20.83	50.46	-29.63	Average
8	0.292	28.48	0.29	0.10	37.82	60.46	-22.64	QP
9	0.404	20.22	0.30	0.10	30.66	47.77	-17.11	Average
10	0.404	24.78	0.30	0.10	35.22	57.77	-22.55	QP
11	12.449	13.07	0.36	0.10	21.67	50.00	-28.33	Average
12	12.449	30.77	0.36	0.10	39.37	60.00	-20.63	QP

Remark: Level = Read Level + LISN/ISN Factor + Cable Loss.

7.4 6dB Occupied Bandwidth

Test Configuration:

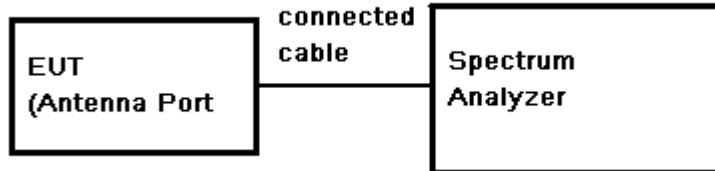

Test Procedure:

1. Place the EUT on the table and set it in transmitting mode.
2. Remove the antenna from the EUT and then connect a low loss RF cable from the antenna port to the spectrum analyzer.
3. Set the spectrum analyzer as RBW=300KHz, VBW≥3* RBW, Span=30/50MHz, Sweep=auto
4. Mark the peak frequency and -6dB (upper and lower) frequency.
5. Repeat above procedures until all frequency measured was complete.

Limit: ≥ 500 kHz

Test Result: Pass

Test Data:

Antenna A:

Test mode: 802.11b

CH	Frequency (MHz)	Bandwidth (MHz)	Limit Bandwidth (KHz)	Result
Low	2412	10.00	500	PASS
Mid	2437	10.88	500	PASS
High	2462	10.68	500	PASS

Test mode: 802.11g

CH	Frequency (MHz)	Bandwidth (MHz)	Limit Bandwidth (KHz)	Result
Low	2412	16.62	500	PASS
Mid	2437	16.56	500	PASS
High	2462	16.65	500	PASS

Antenna B:

Test mode: 802.11b

CH	Frequency (MHz)	Bandwidth (MHz)	Limit Bandwidth (KHz)	Result
Low	2412	10.80	500	PASS
Mid	2437	10.88	500	PASS
High	2462	10.96	500	PASS

Test mode: 802.11g

CH	Frequency (MHz)	Bandwidth (MHz)	Limit Bandwidth (KHz)	Result
Low	2412	16.62	500	PASS
Mid	2437	16.62	500	PASS
High	2462	16.62	500	PASS

Test plot as follows:

Antenna A:

Test mode: 802.11b

Channel: Lowest

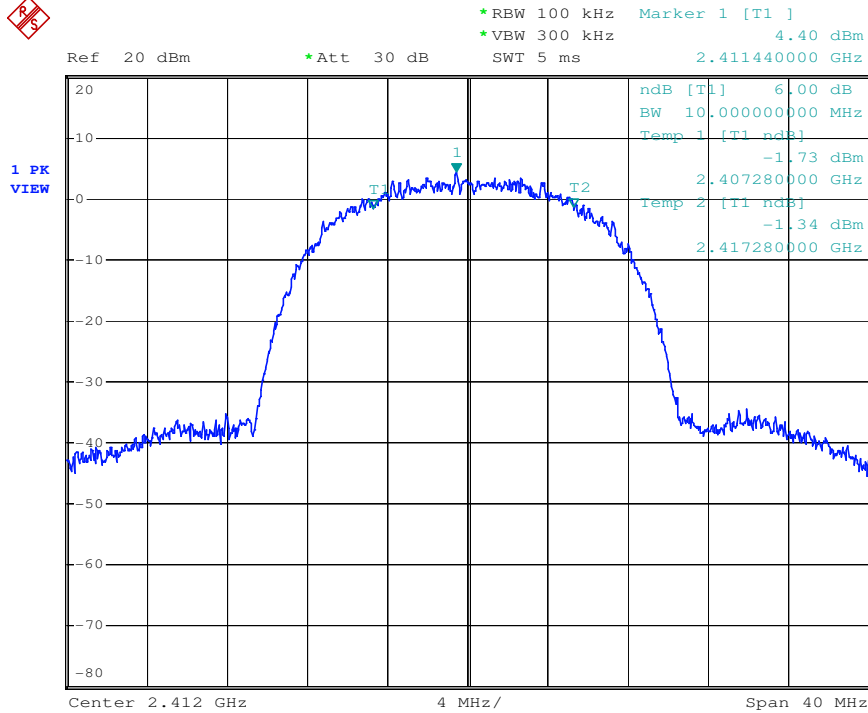

Test mode: 802.11b

Channel: Middle

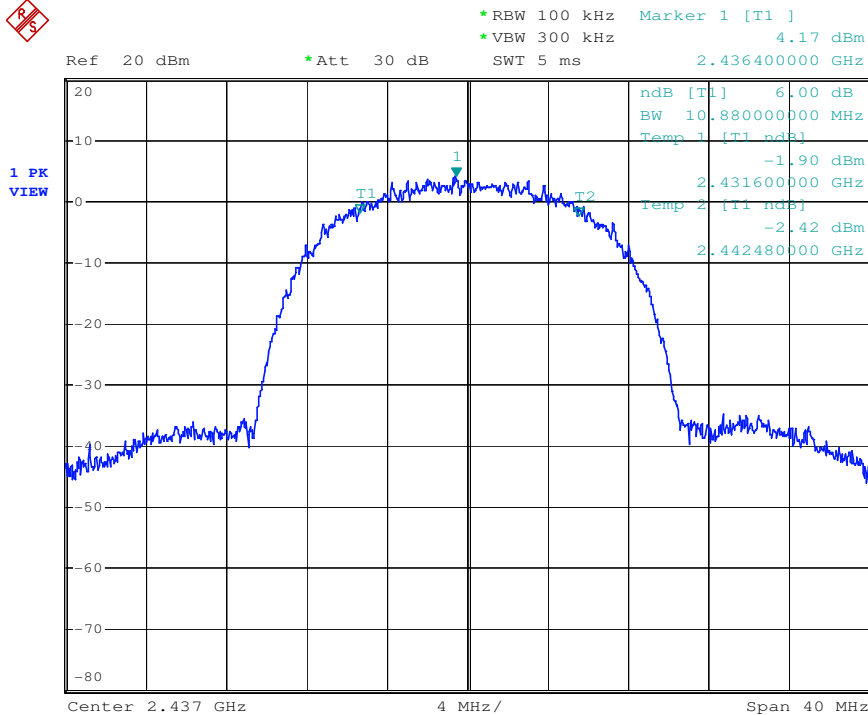

Test mode: 802.11b

Channel: Highest

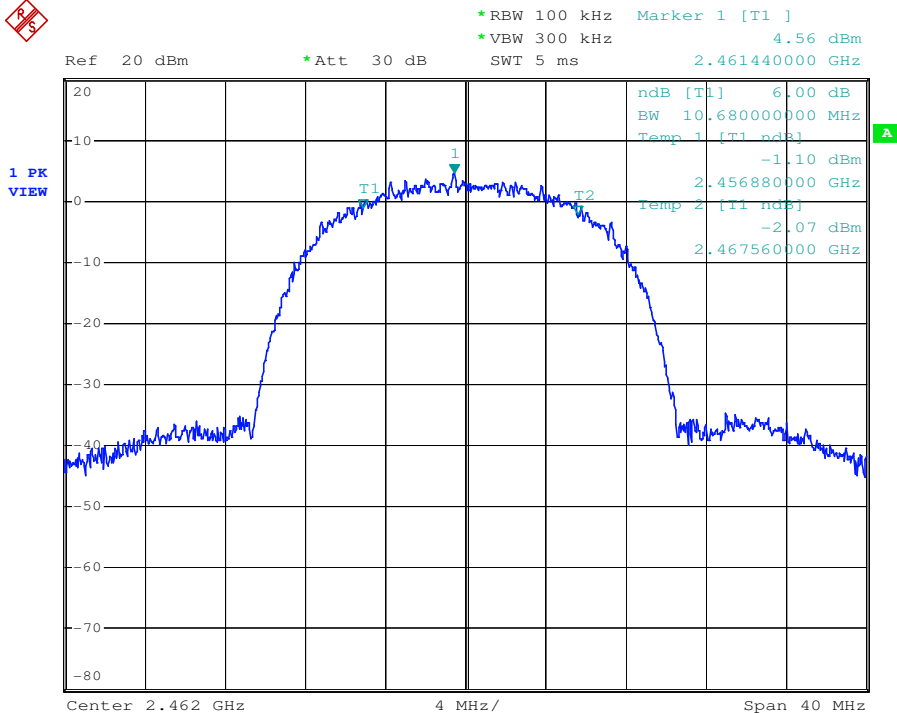

Test mode: 802.11g

Channel: Lowest

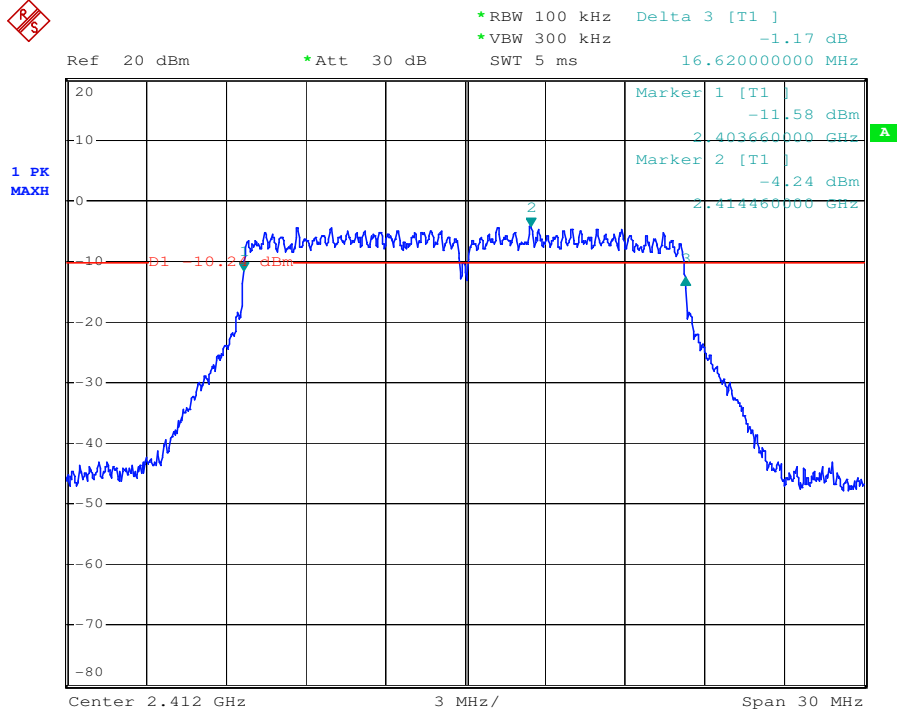

Test mode: 802.11g

Channel: Middle

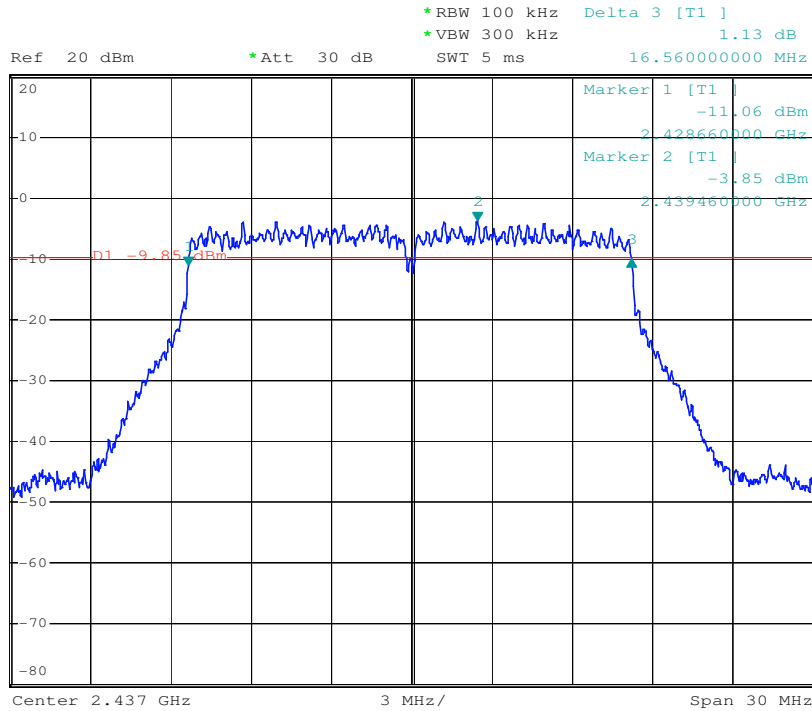

Test mode: 802.11g

Channel: Highest

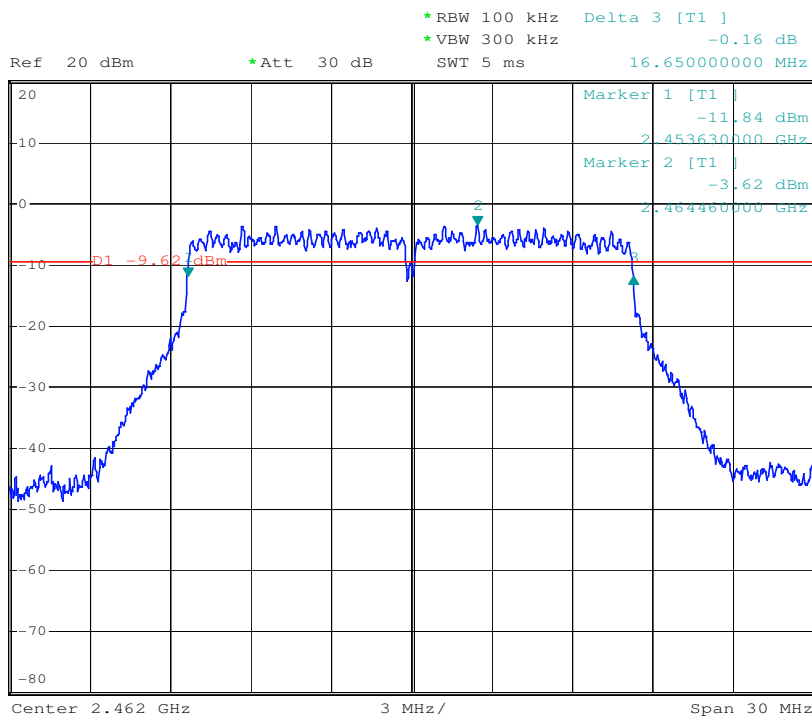

Antenna B:

Test mode: 802.11b

Channel: Lowest

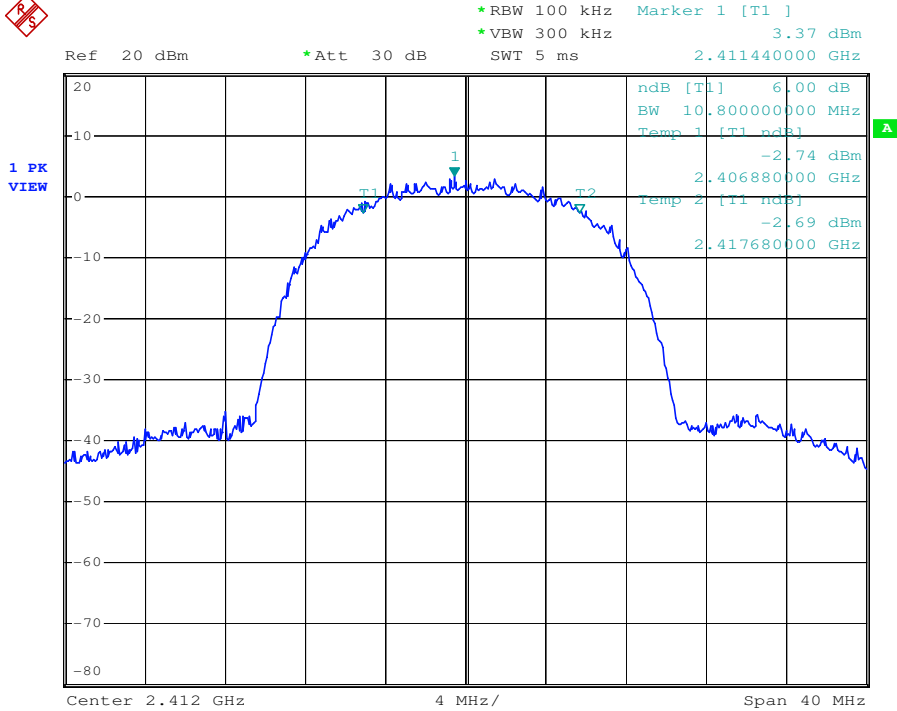

Test mode: 802.11b

Channel: Middle

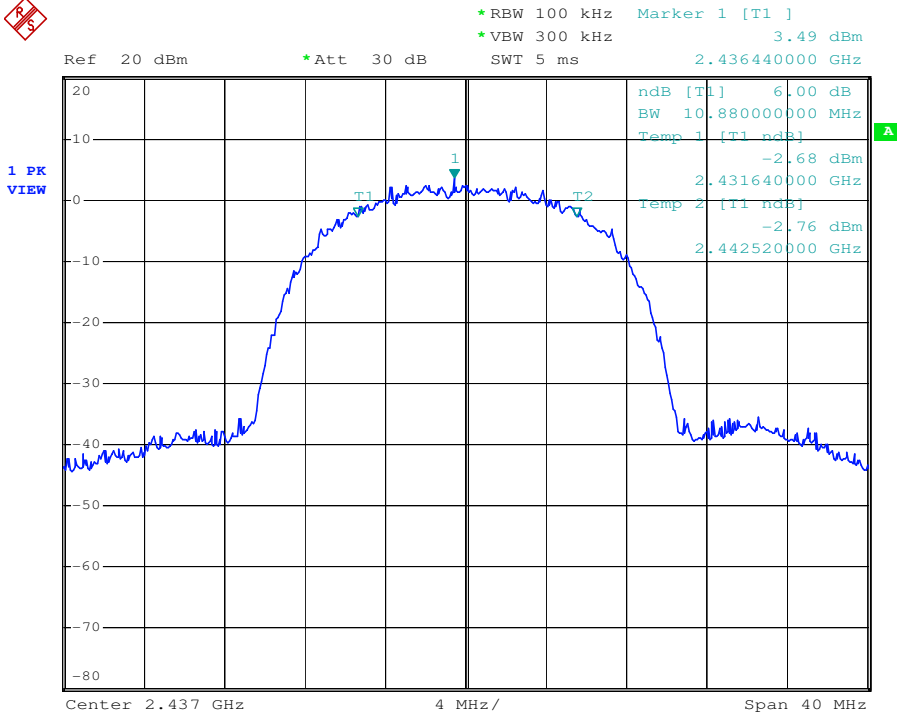

Test mode: 802.11b

Channel: Highest

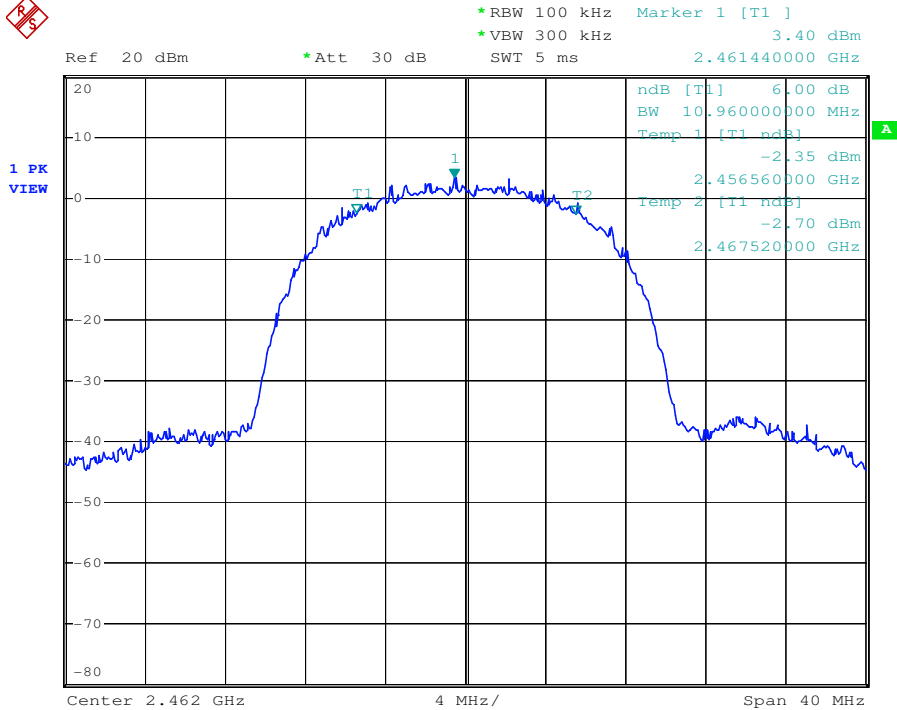

Test mode: 802.11g

Channel: Lowest

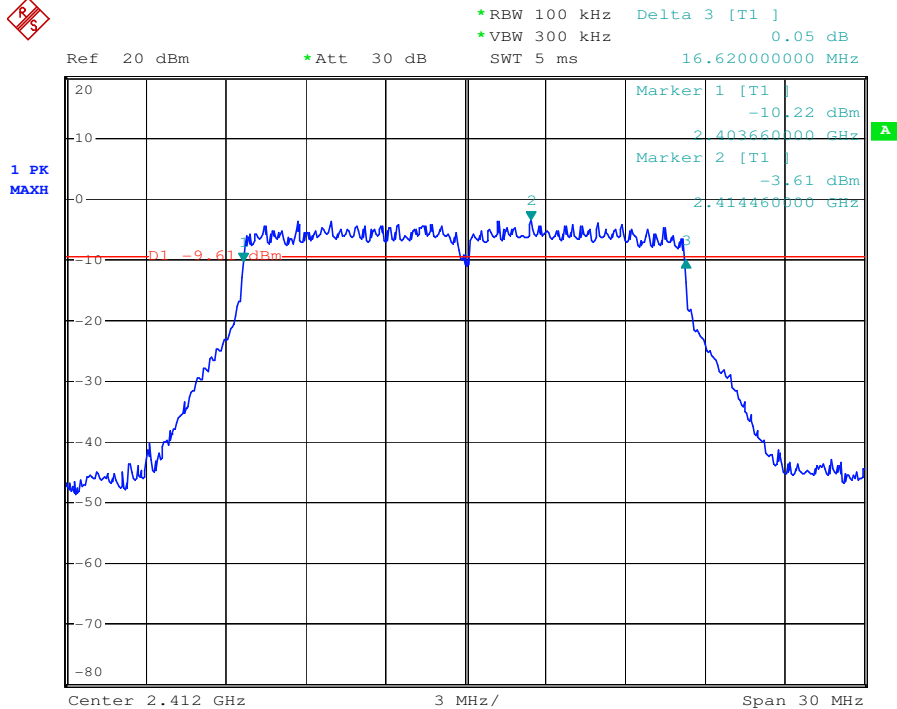

Test mode: 802.11g

Channel: Middle

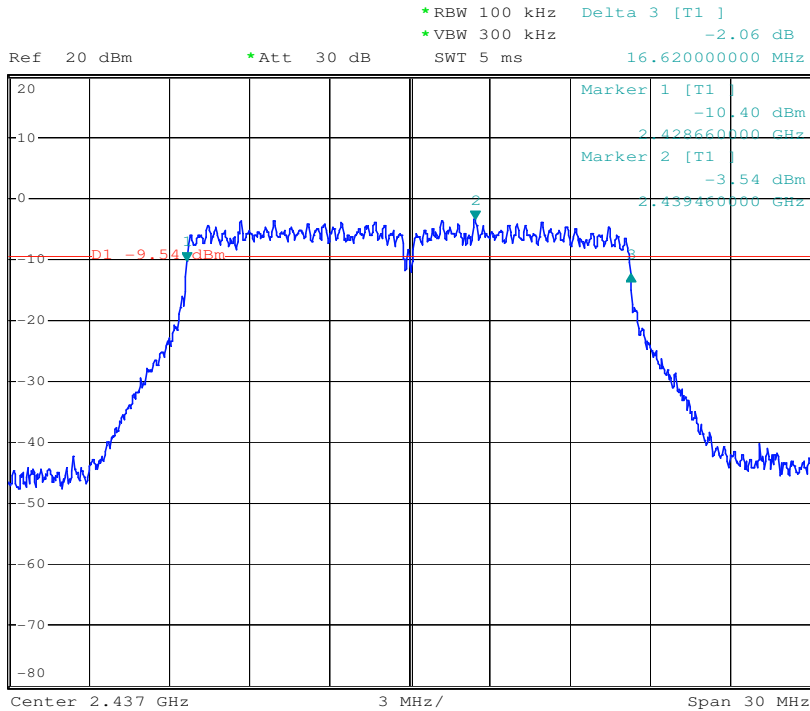

Test mode: 802.11g

Channel: Highest

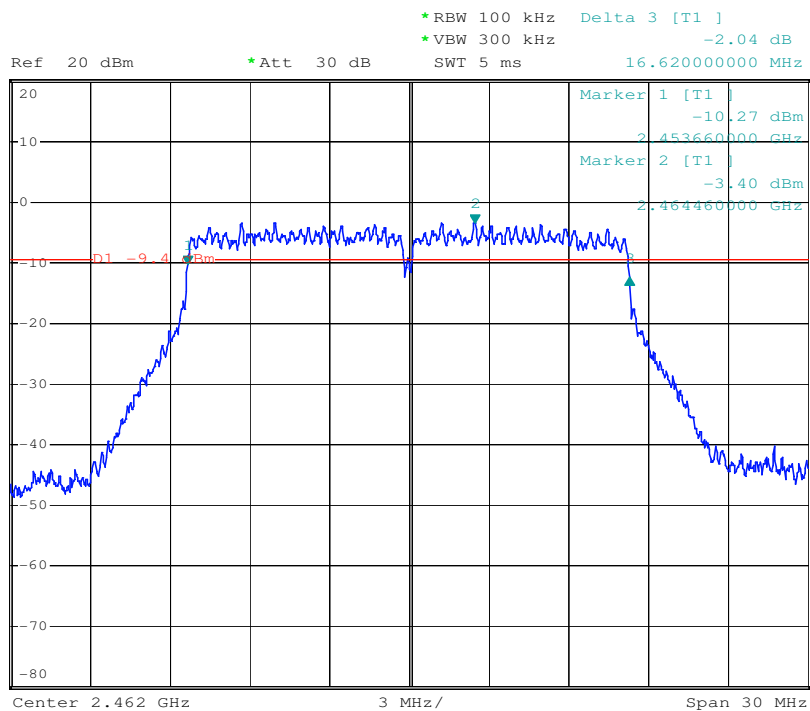

7.5 Conducted Peak Output Power

Test Configuration:

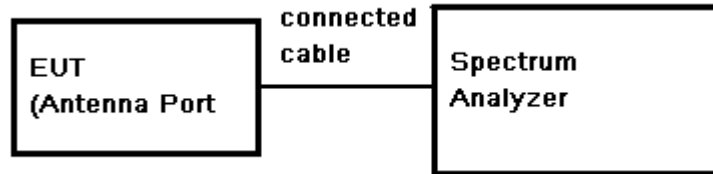

Test Procedure:

1. Place the EUT on the table and set it in transmitting mode.
2. Remove the antenna from the EUT and then connect a low loss RF cable from the antenna port to the spectrum.
3. Set the occur band to the entire emission 6dB bandwidth of the signal.
4. Record the max. Power channel reading.
5. Repeat above procedures until all the frequency measured were complete.

Test Limit: 30dBm

Test Result: Pass

**Test Data:
Antenna A:**

Test mode	Test Channel	Reading Power (dBm)	Cable Loss (dB)	Output Power (dBm)	Output Power (mW)	Power Limit (dBm)	Result
802.11b	Lowest	16.35	0.5	16.85	48.42	30	PASS
	Middle	16.86	0.5	17.36	54.45	30	PASS
	Highest	17.33	0.5	17.83	60.67	30	PASS
802.11g	Lowest	16.83	0.5	17.33	54.08	30	PASS
	Middle	17.18	0.5	17.68	58.61	30	PASS
	Highest	17.25	0.5	17.75	59.57	30	PASS

Antenna B:

Test mode	Test Channel	Reading Power (dBm)	Cable Loss (dB)	Output Power (dBm)	Output Power (mW)	Power Limit (dBm)	Result
802.11b	Lowest	16.44	0.5	16.94	49.43	30	PASS
	Middle	16.81	0.5	17.31	53.83	30	PASS
	Highest	17.09	0.5	17.59	57.41	30	PASS
802.11g	Lowest	16.95	0.5	17.45	55.59	30	PASS
	Middle	17.09	0.5	17.59	57.41	30	PASS
	Highest	17.01	0.5	17.51	56.36	30	PASS

Remark: Output Peak Power = Reading Peak Power + Cable loss

Test result plot as follows:

Antenna A:

Test mode: 802.11b

Channel: Lowest

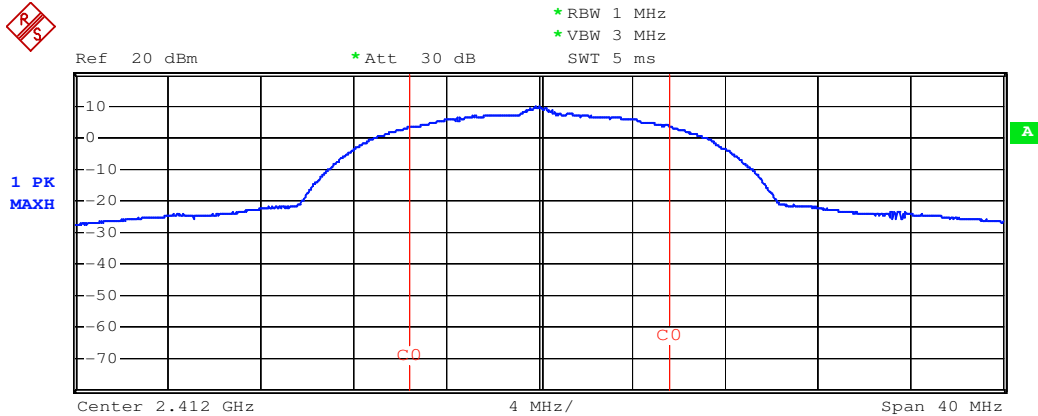

Test mode: 802.11b

Channel: Middle

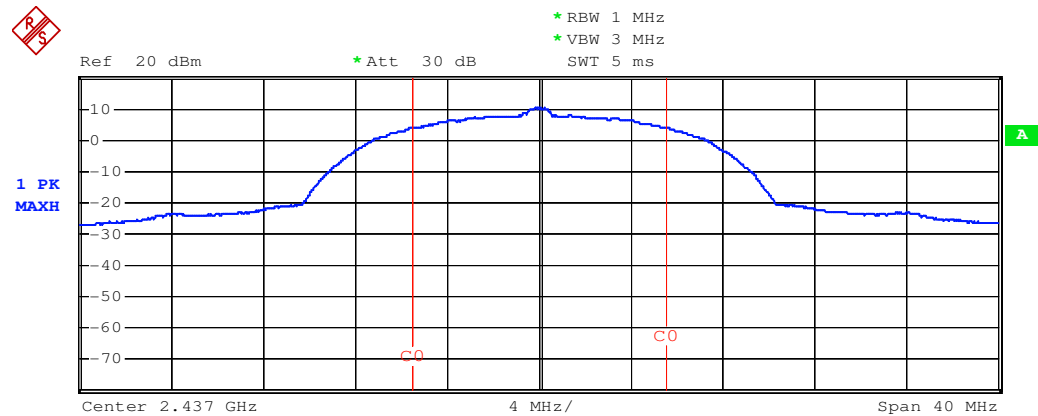

Test mode: 802.11b

Channel: Highest

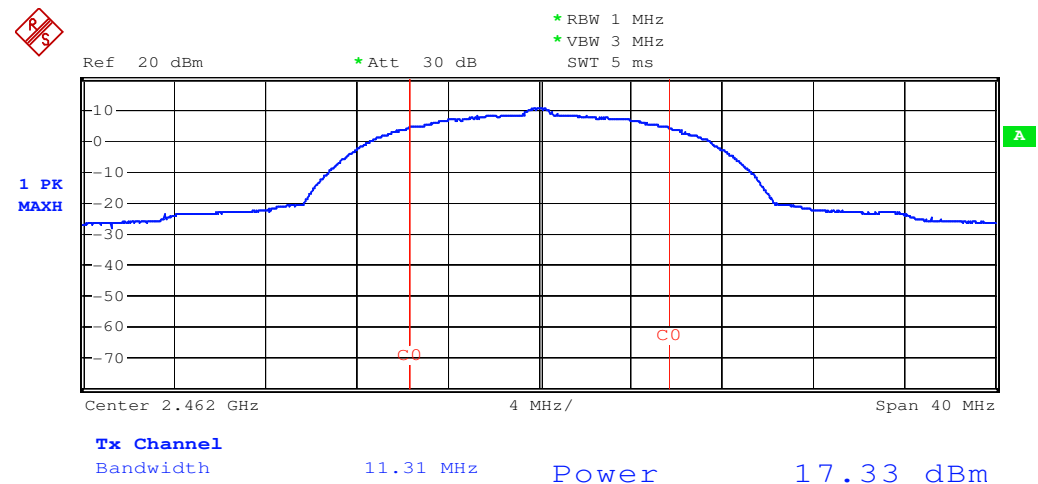

Test mode: 802.11g

Channel: Lowest

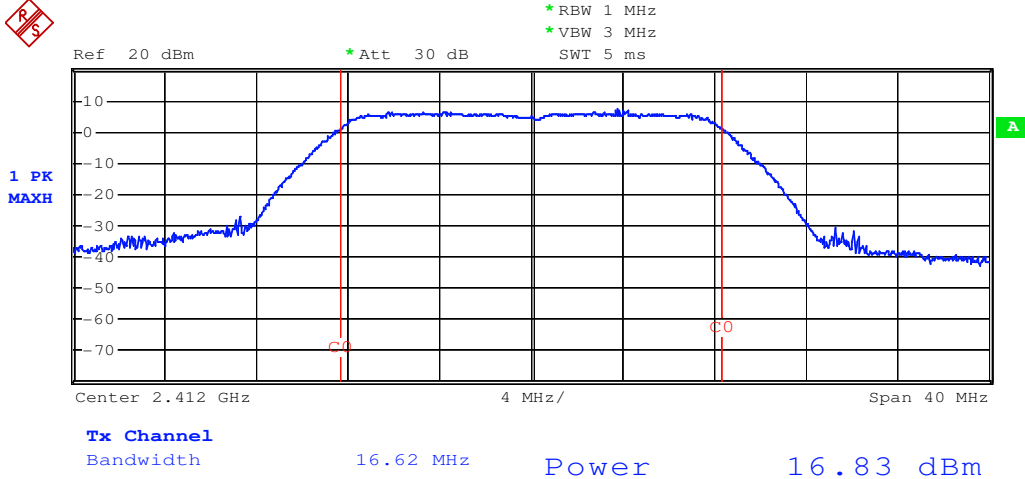

Test mode: 802.11g

Channel: Middle

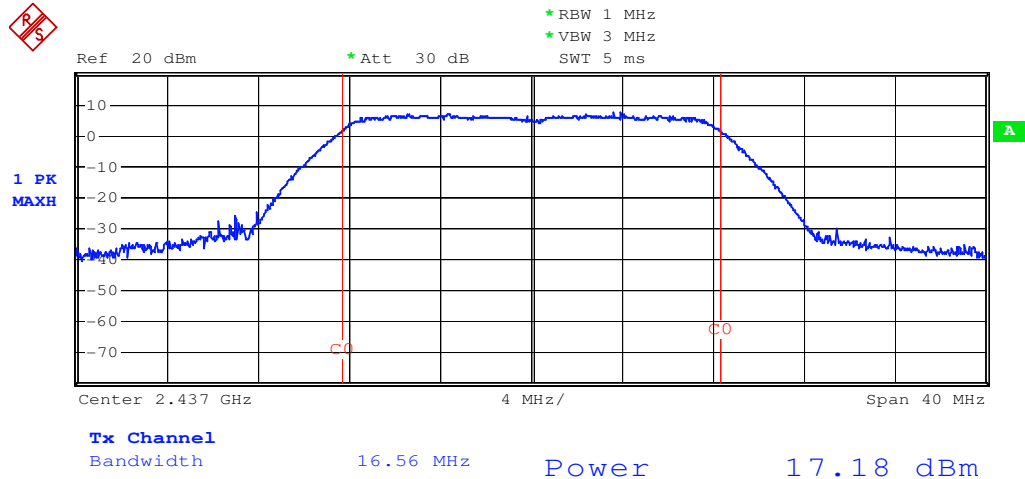

Test mode: 802.11g

Channel: Highest

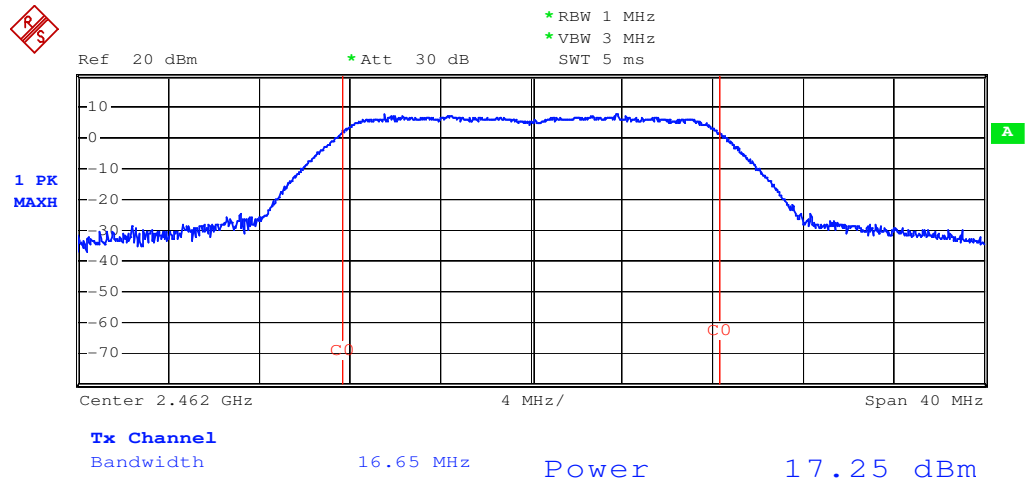

Antenna B:

Test mode: 802.11b

Channel: Lowest

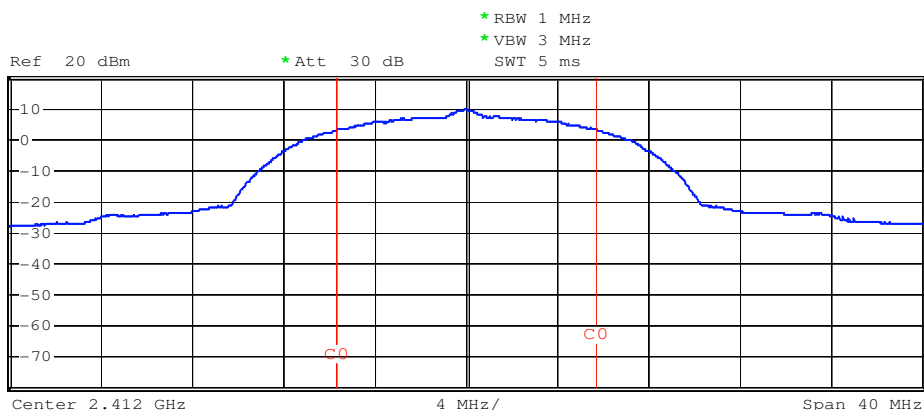

Test mode: 802.11b

Channel: Middle

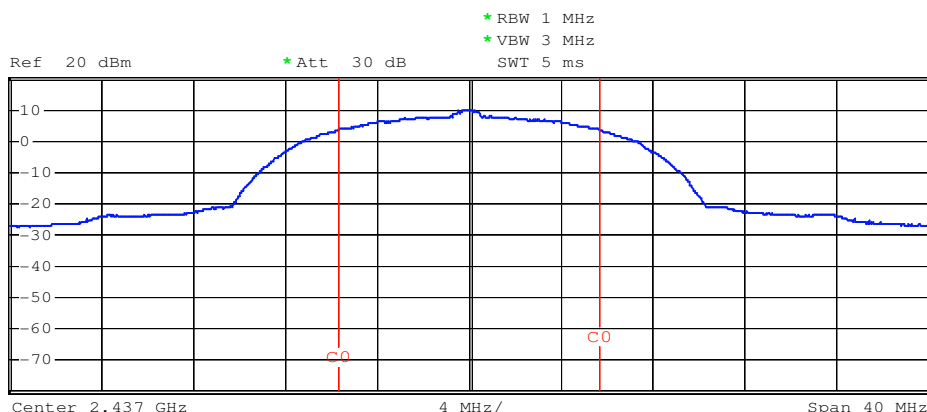

Test mode: 802.11b

Channel: Highest

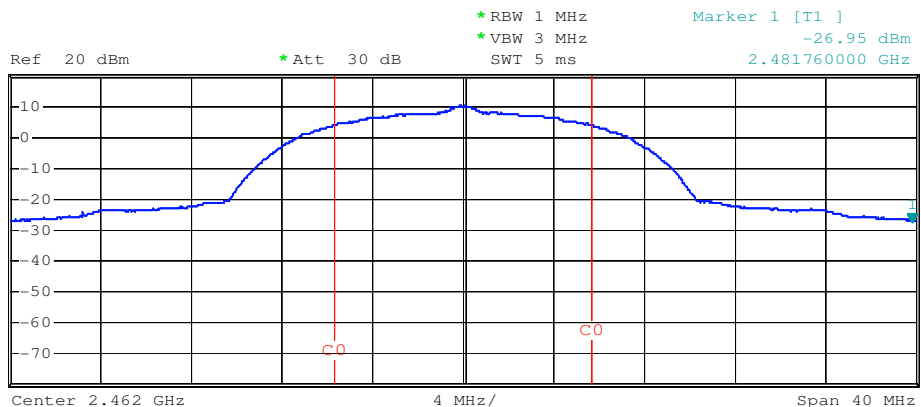

7.6 Peak Power Spectral Density

Test Configuration:

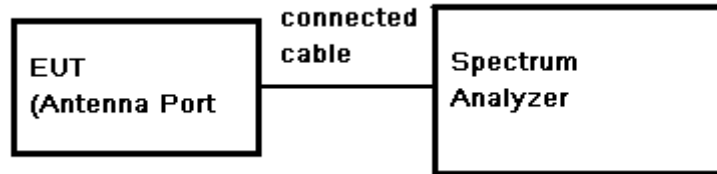

Test Procedure:

- 1) Remove the antenna from the EUT and then connect a low RF cable from the antenna port to the spectrum.
- 2) Set the spectrum analyzer: Center Frequency= Channel Frequency, RBW = 3 kHz VBW = 10 kHz. Span= fully encompass the bandwidth, Sweep = auto; Detector Function = Peak; Trace mode=max hold, MKR=Center Frequency, Trace=Clear Write.
- 3) Set the marker on the peak of the signal and then adjust the center frequency of the spectrum analyzer to the marker frequency.
- 4) Adjust the Span = 300 kHz, Sweep Time=100s, Trace=Max Hold, MKR=Peak Search.
- 5) Record the marker level for the particular mode.
- 6) Repeat these steps for other channel and device modes.

Test Limit: 8dBm/3kHz

Test Result: Pass

**Test Data:
Antenna A:**

Test mode: 802.11b

CH	Frequency (MHz)	Reading (dBm)	Cable Loss (dB)	RF Power Density (dBm)	Limit (dBm)	Result
LOW	2412	-9.52	0.5	-7.02	8	PASS
MID	2437	0.40	0.5	2.90	8	PASS
HIGH	2462	0.47	0.5	2.97	8	PASS

Test mode: 802.11g

CH	Frequency (MHz)	Reading (dBm)	Cable Loss (dB)	RF Power Density (dBm)	Limit (dBm)	Result
LOW	2412	-12.51	0.5	-10.01	8	PASS
MID	2437	-12.75	0.5	-10.25	8	PASS
HIGH	2462	-12.84	0.5	-10.34	8	PASS

Antenna B:

Test mode: 802.11b

CH	Frequency (MHz)	Reading (dBm)	Cable Loss (dB)	RF Power Density (dBm)	Limit (dBm)	Result
LOW	2412	0.12	0.5	2.62	8	PASS
MID	2437	-5.06	0.5	-2.56	8	PASS
HIGH	2462	-7.80	0.5	-5.30	8	PASS

Test mode: 802.11g

CH	Frequency (MHz)	Reading (dBm)	Cable Loss (dB)	RF Power Density (dBm)	Limit (dBm)	Result
LOW	2412	-13.05	0.5	-10.55	8	PASS
MID	2437	-11.87	0.5	-9.37	8	PASS
HIGH	2462	-12.38	0.5	-9.88	8	PASS

Remark: RF Power Density = Reading + Cable loss + Antenna Gain

Test result plot as follows:

Antenna A:

Test mode: 802.11b

Channel: Lowest

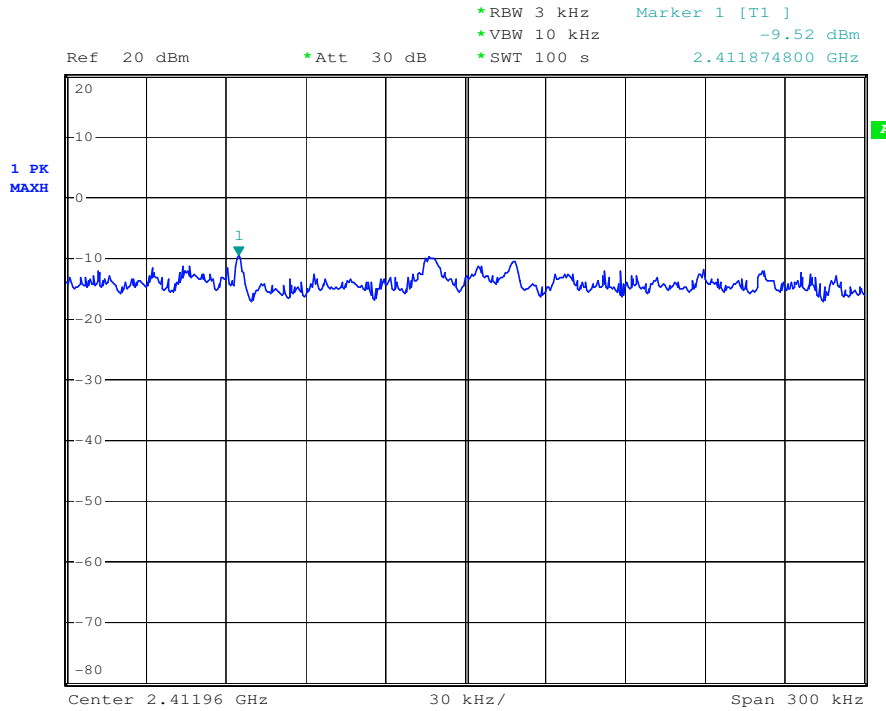

Test mode: 802.11b

Channel: Middle

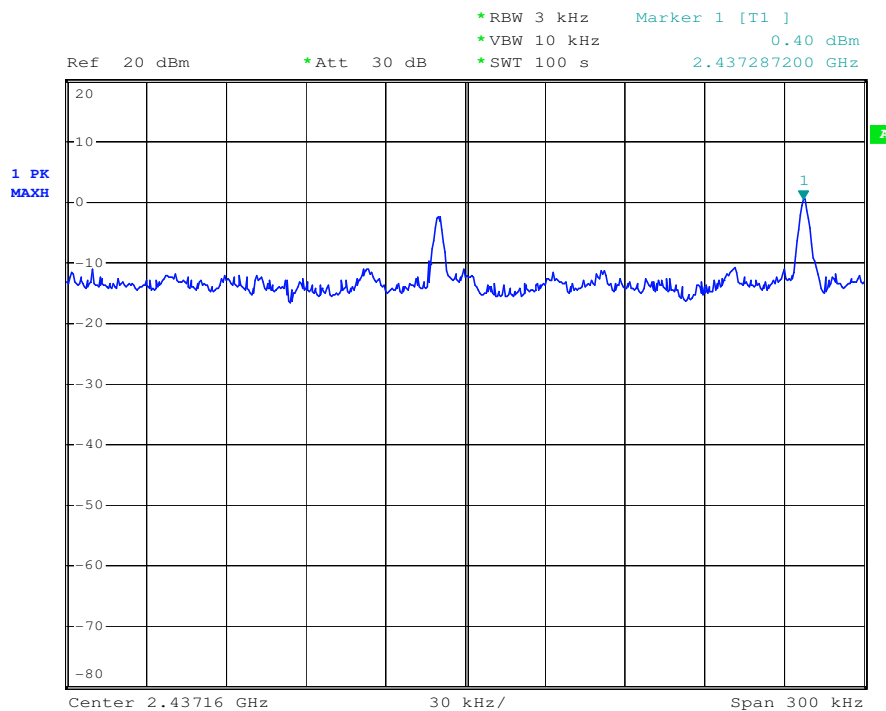

Test mode: 802.11g

Channel: Middle

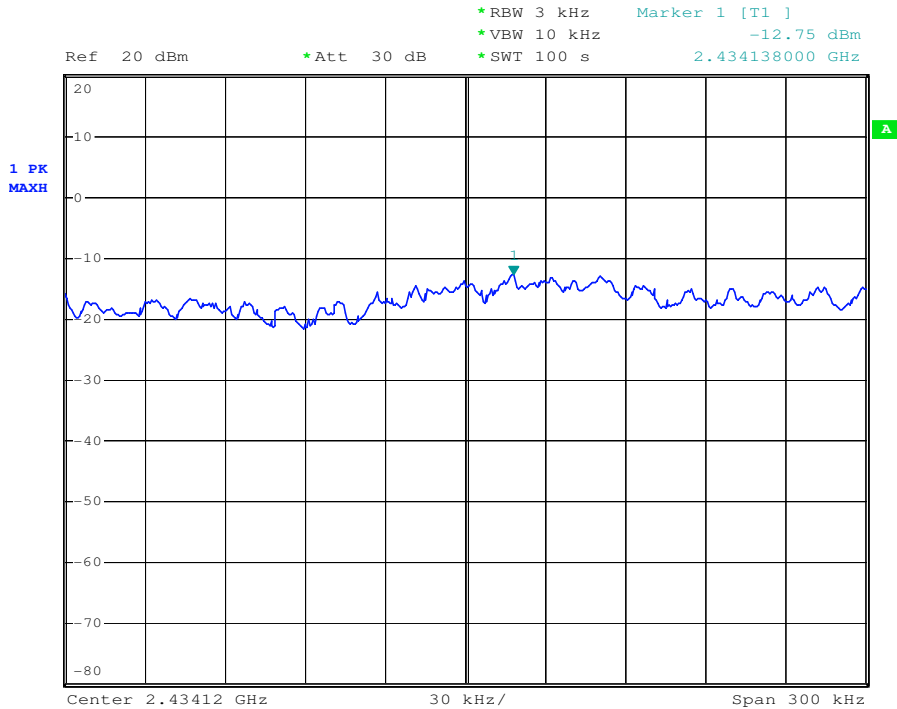

Test mode: 802.11g

Channel: Highest

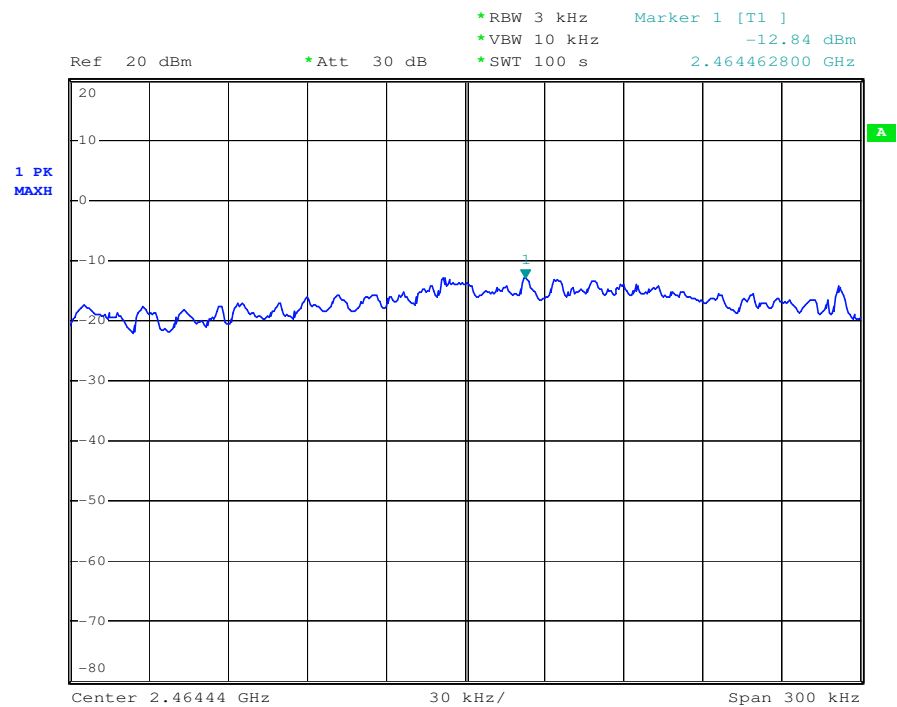

Test mode: 802.11g

Channel: Middle

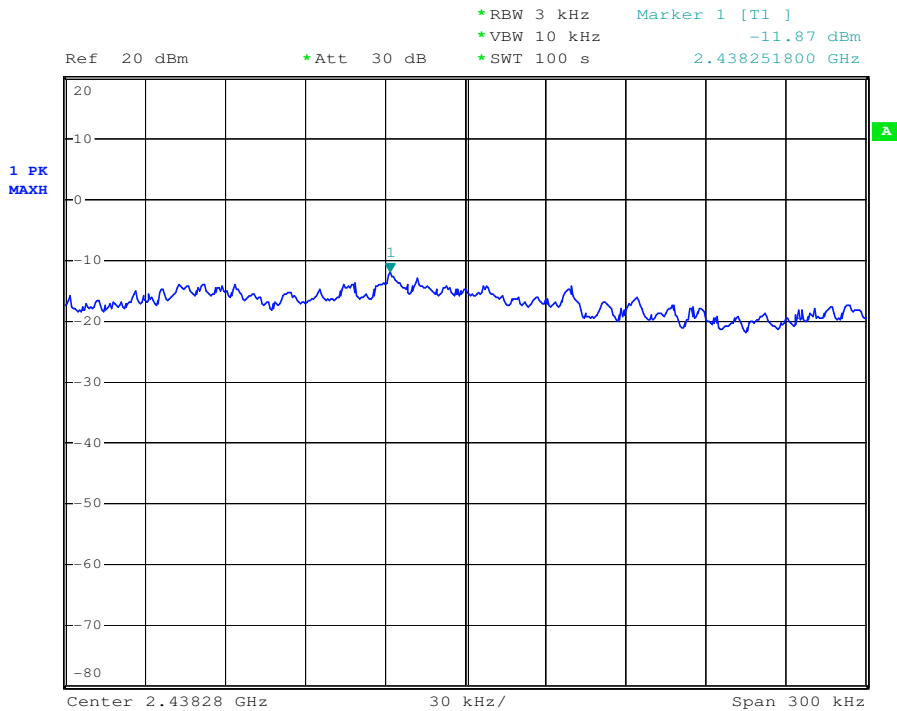

Test mode: 802.11g

Channel: Highest

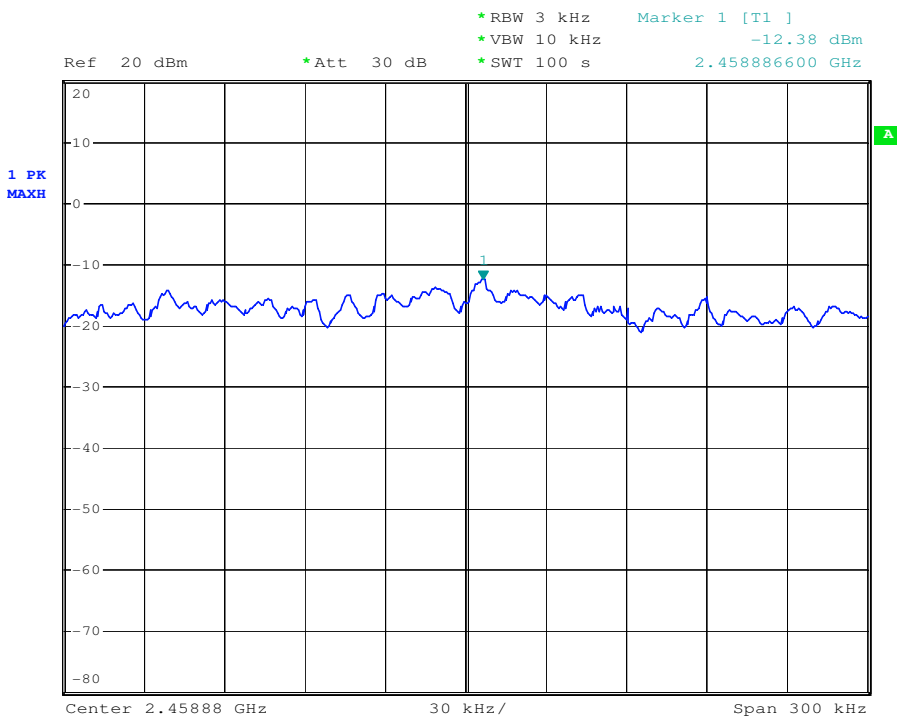

7.7 Conducted Spurious Emissions and Band-edge

Test Configuration:

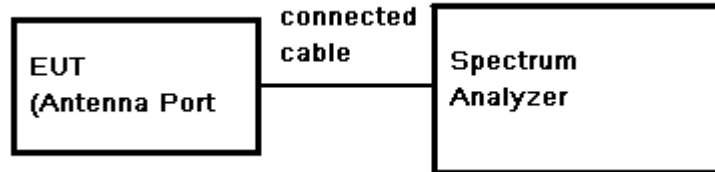

Test Procedure:

1. Remove the antenna from the EUT and then connect a low RF cable from the antenna port to the spectrum.
2. Set the spectrum analyzer: RBW = 100KHz. VBW >= RBW. Sweep = auto; Detector Function = Peak (Max. hold).

Limit:

(d) In any 100 kHz bandwidth outside the frequency band in which the spread spectrum or digitally modulated intentional radiator is operating, the radio frequency power that is produced by the intentional radiator shall be at least 20 dB below that in the 100 kHz bandwidth within the band that contains the Highest level of the desired power, based on either an RF conducted or a radiated measurement, provided the transmitter demonstrates compliance with the peak conducted power limits.

Test Result:

Pass

7.7.1 Conducted spurious emission

Test plot as follows:
Antenna A:

Test mode: 802.11b

Channel: Lowest

30MHz-3GHz:

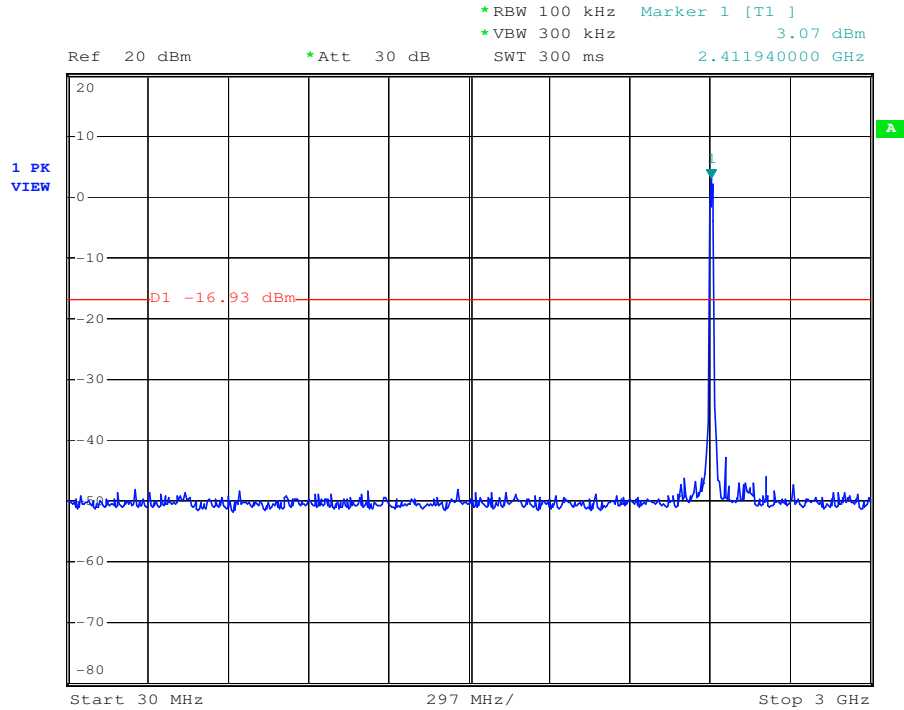

3GHz-25GHz:

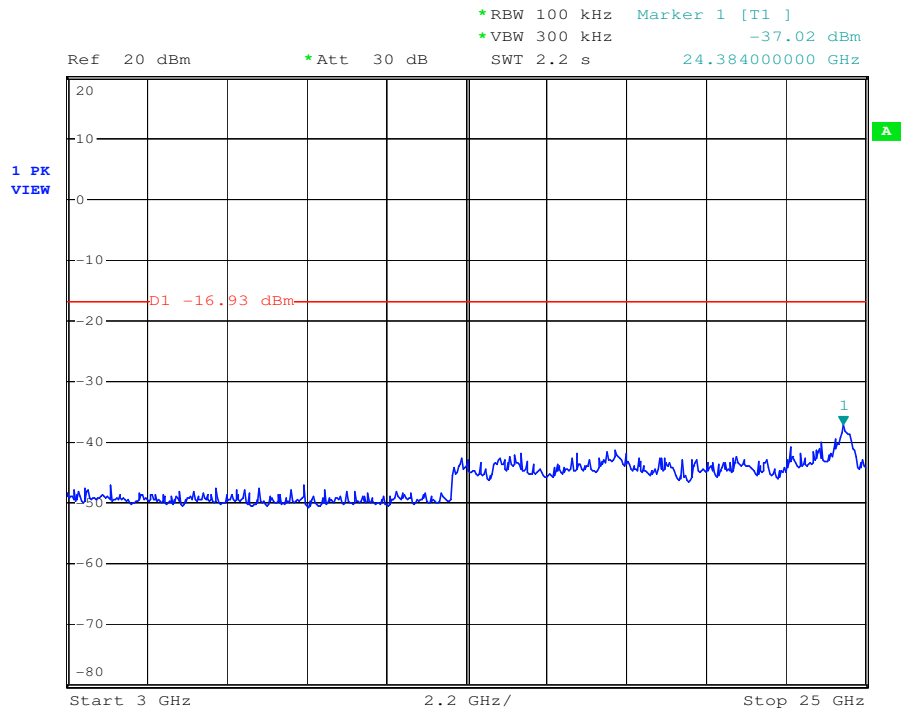

Test mode: 802.11b

Channel: Middle

30MHz-3GHz:

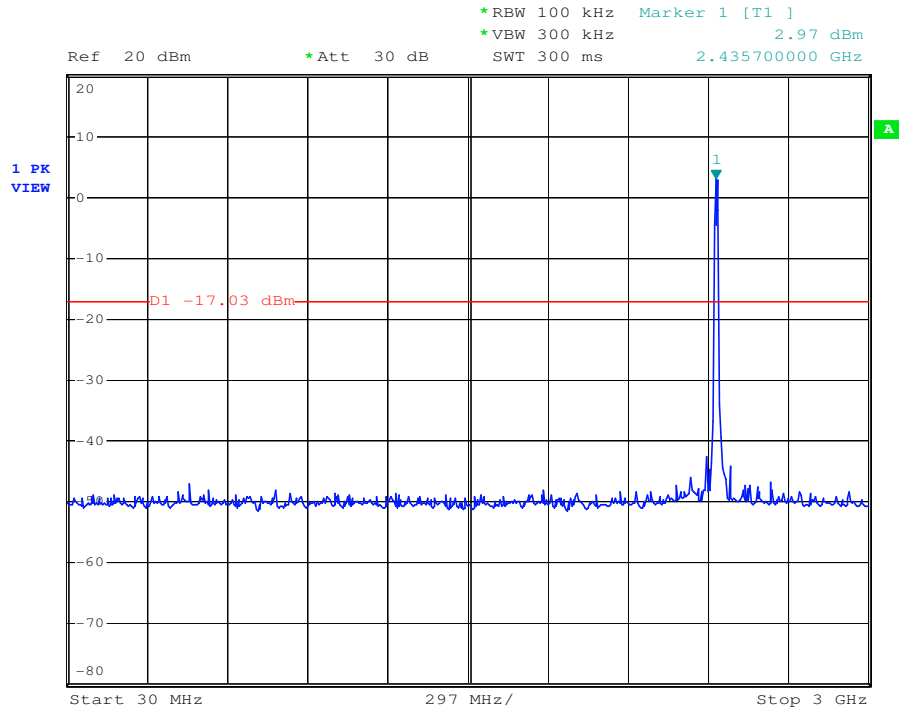

3GHz-25GHz:

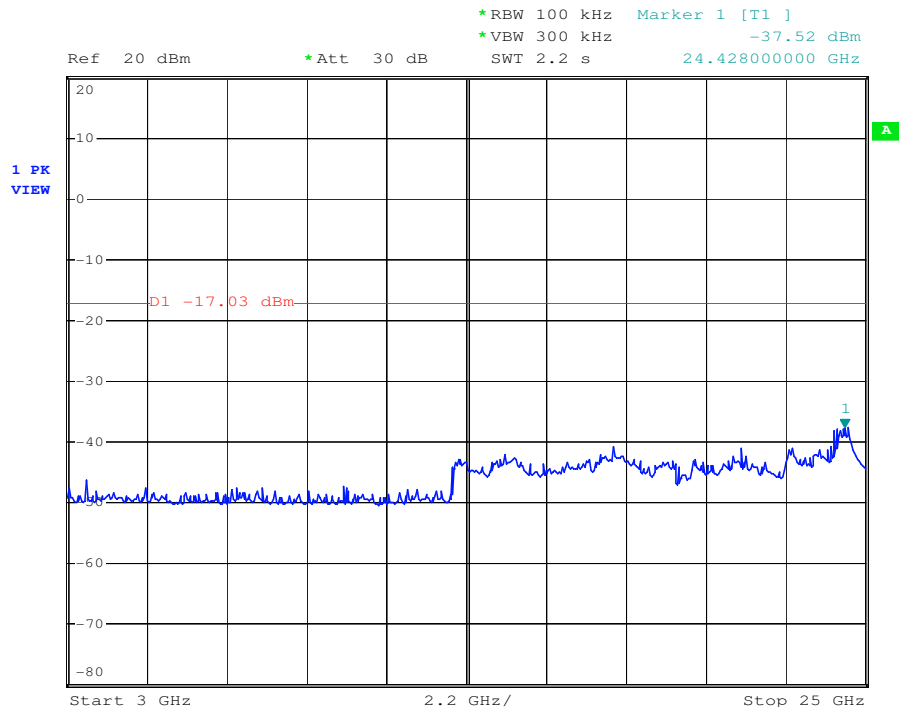

Test mode: 802.11b

Channel: Highest

30MHz-3GHz:

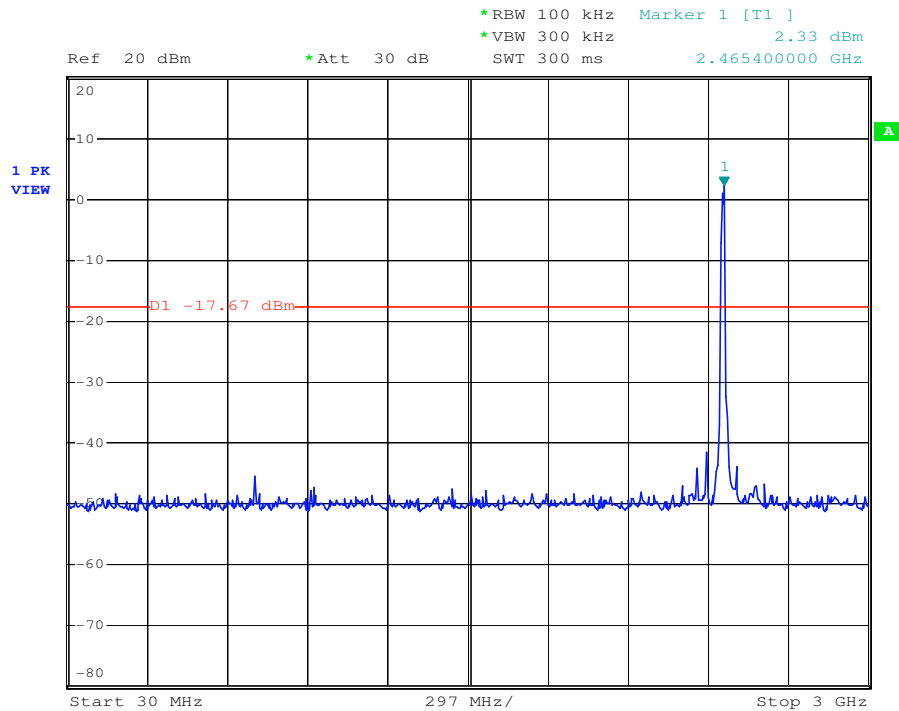

3GHz-25GHz:

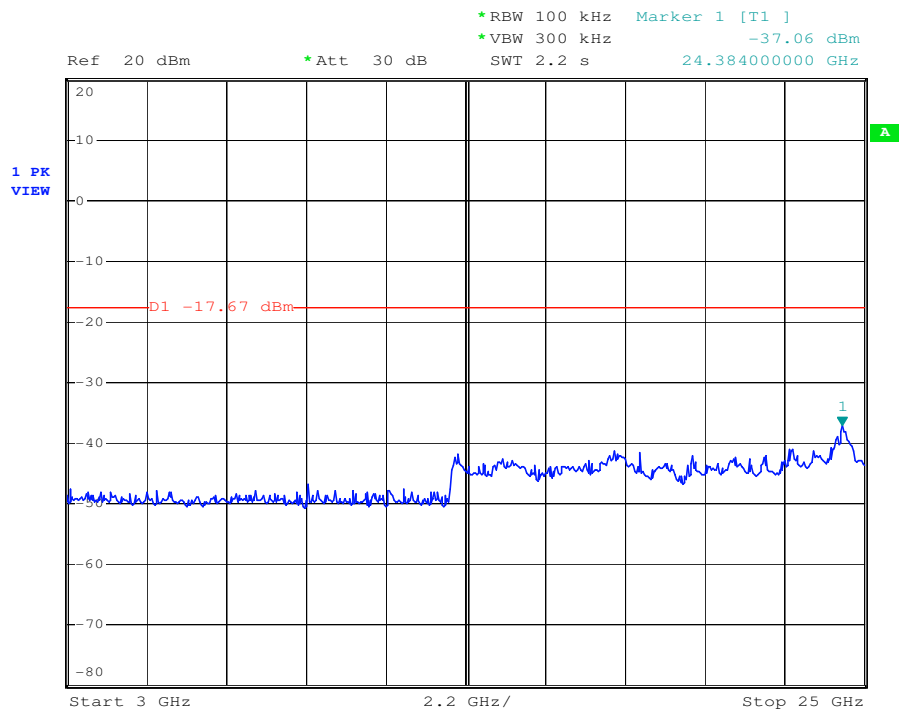

Test mode: 802.11g

Channel: Lowest

30MHz-3GHz:

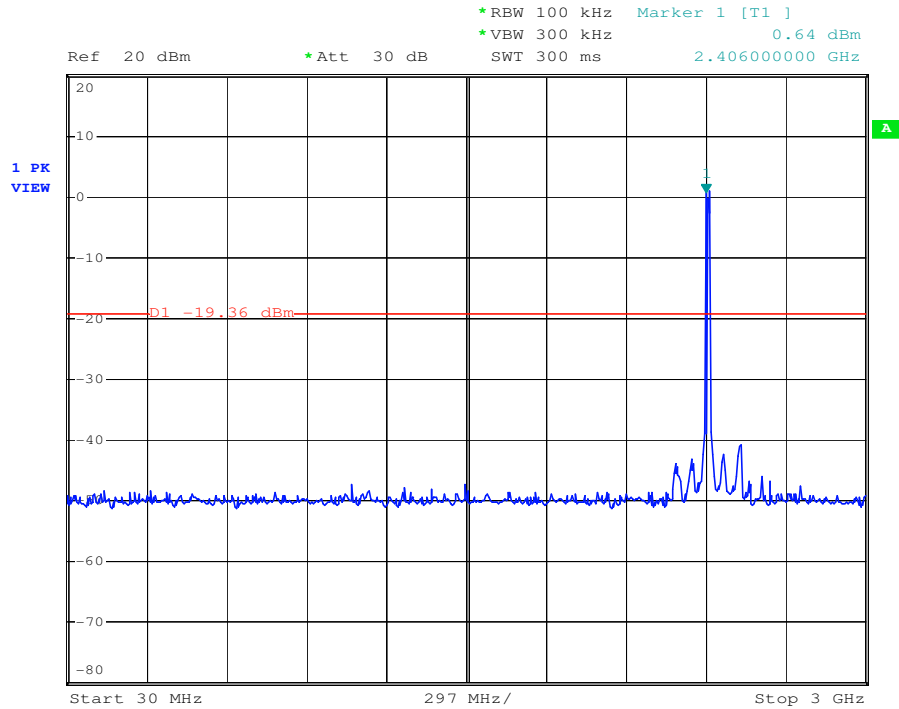

3GHz-25GHz:

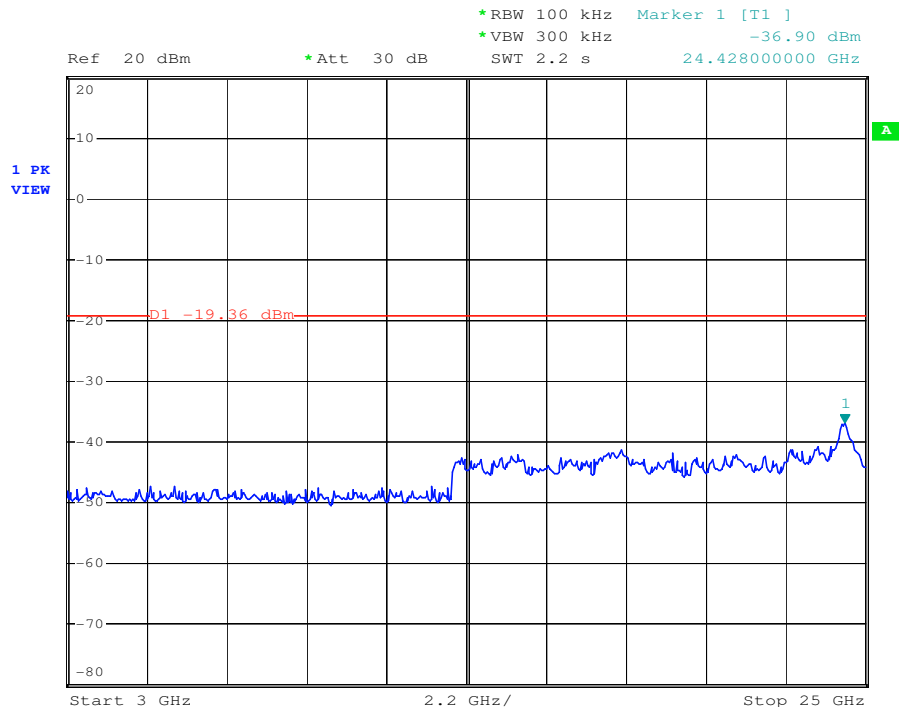

Test mode: 802.11g

Channel: Middle

30MHz-3GHz:

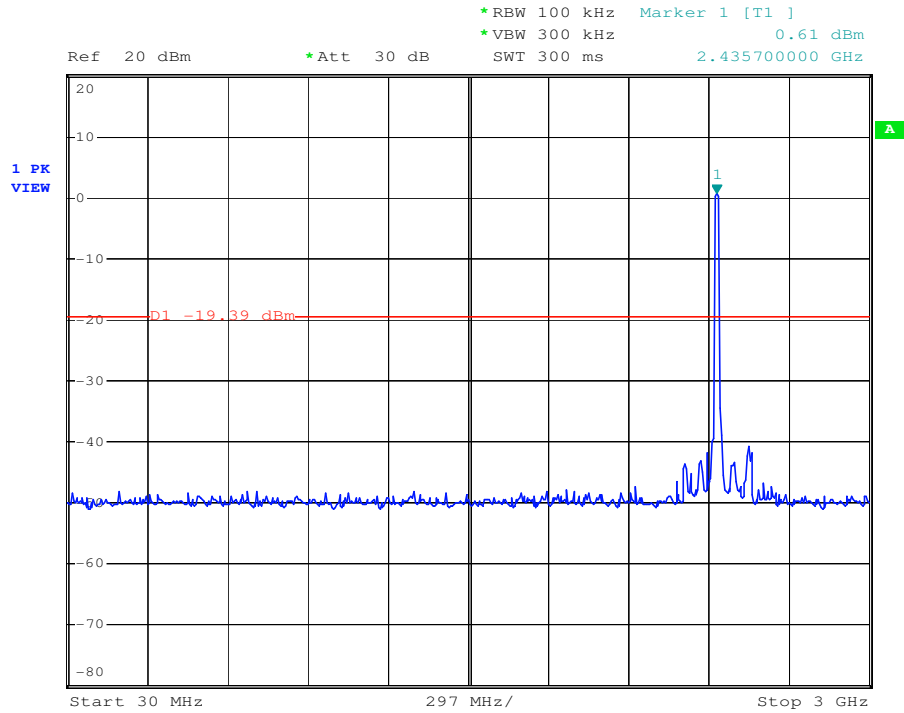

3GHz-25GHz:

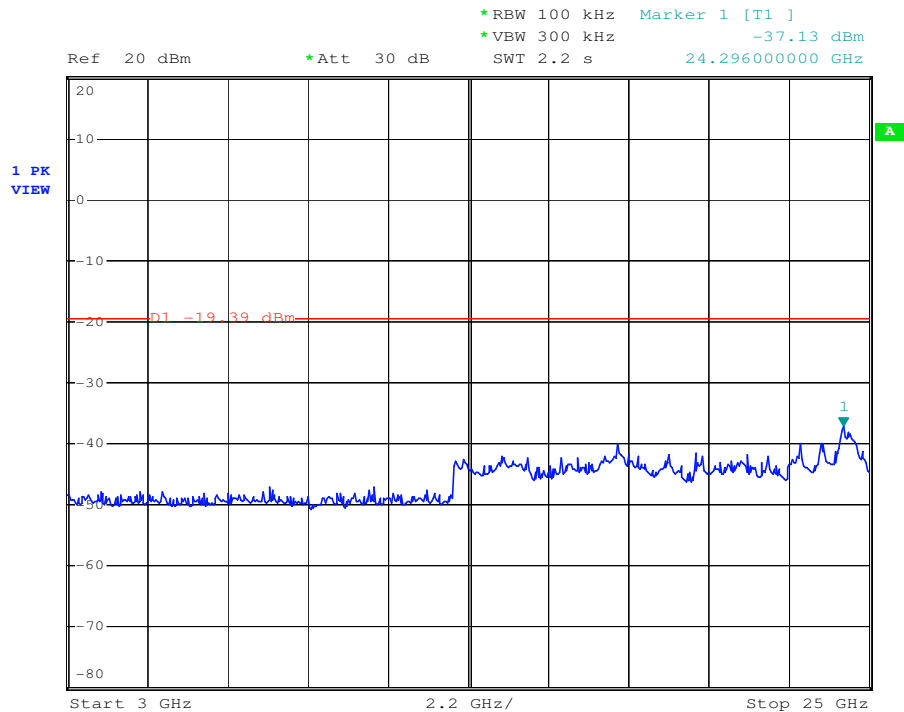

Test mode: 802.11g

Channel: Highest

30MHz-3GHz:

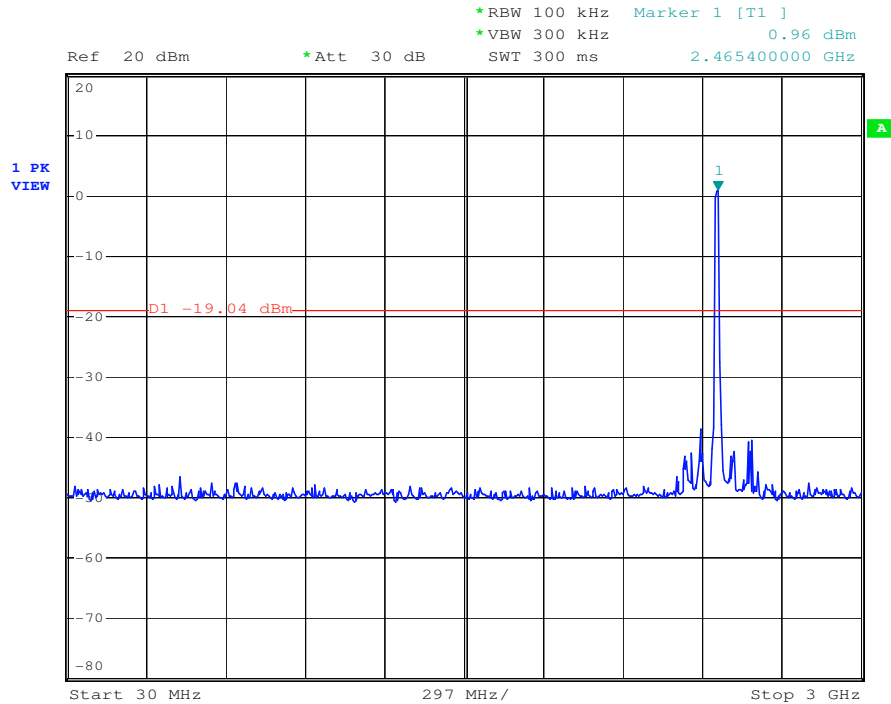

3GHz-25GHz:

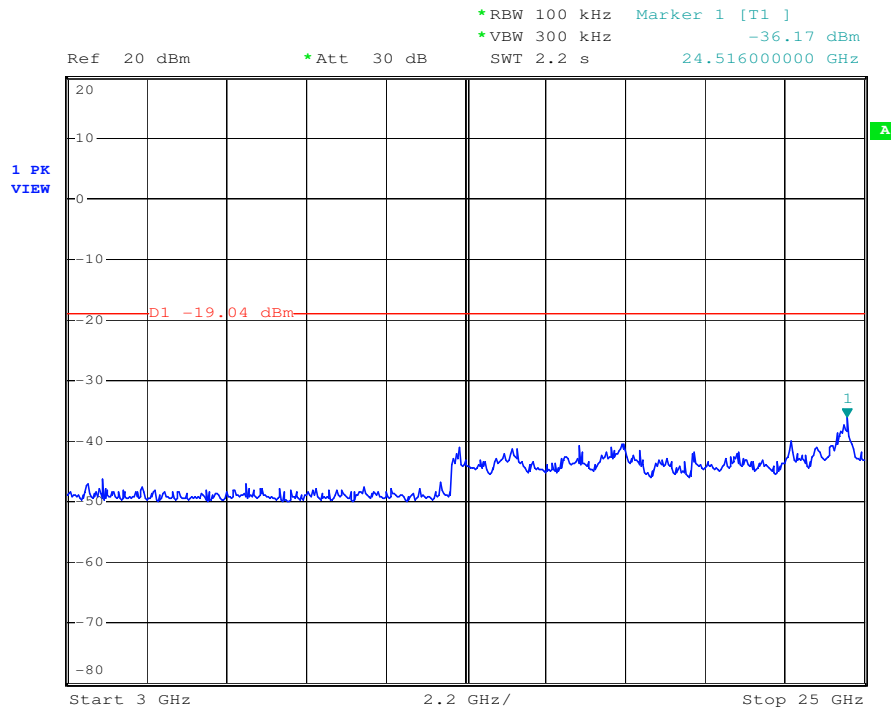

Antenna B:
Test mode: 802.11b

Channel: Lowest

30MHz-3GHz:

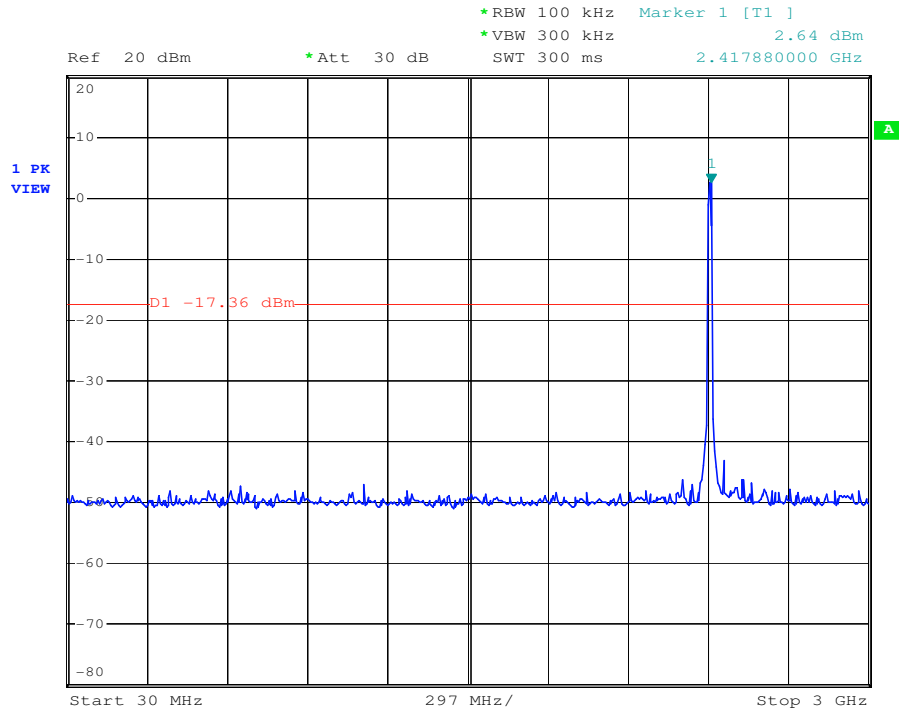

3GHz-25GHz:

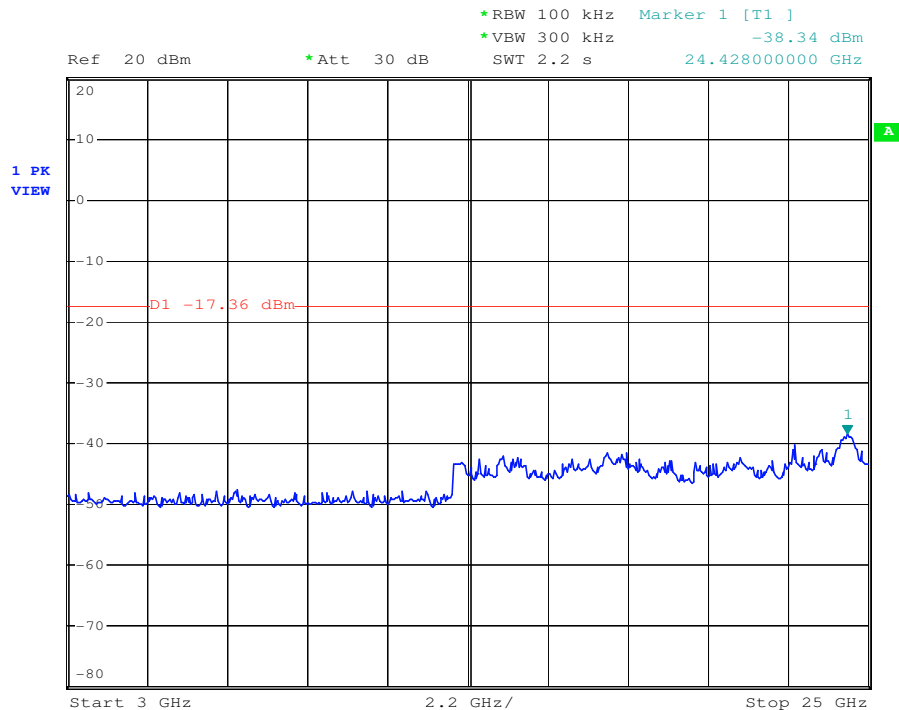

Test mode: 802.11b

Channel: Middle

30MHz-3GHz:

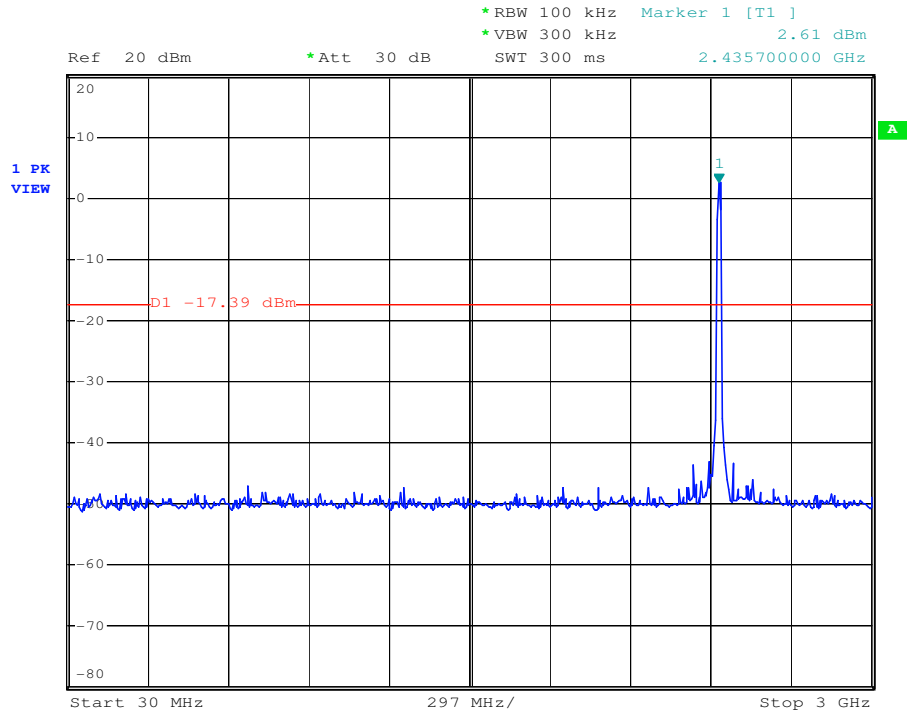

3GHz-25GHz:

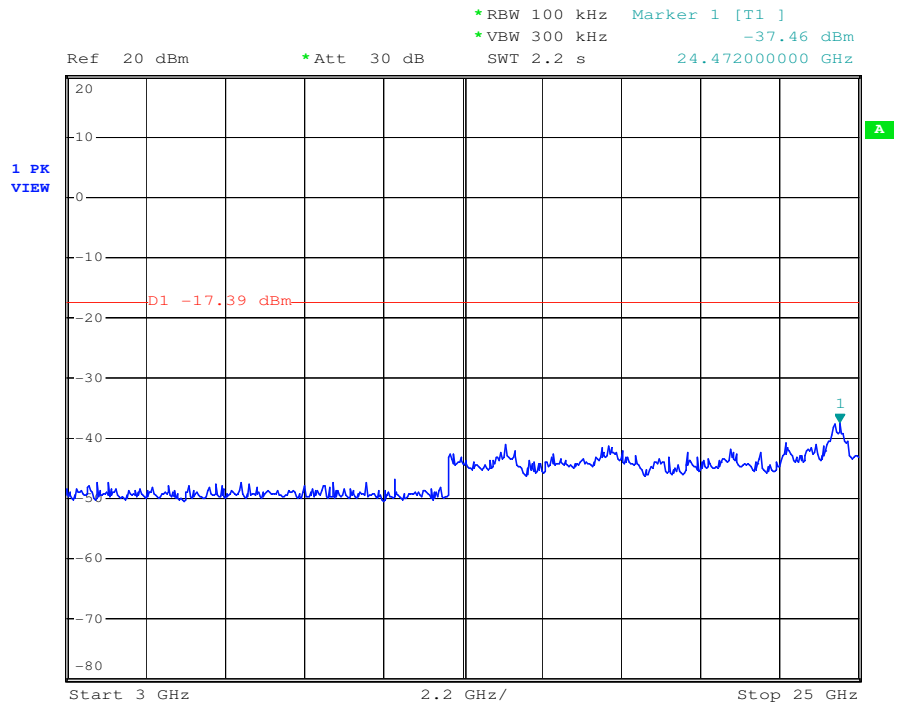

Test mode: 802.11b

Channel: Highest

30MHz-3GHz:

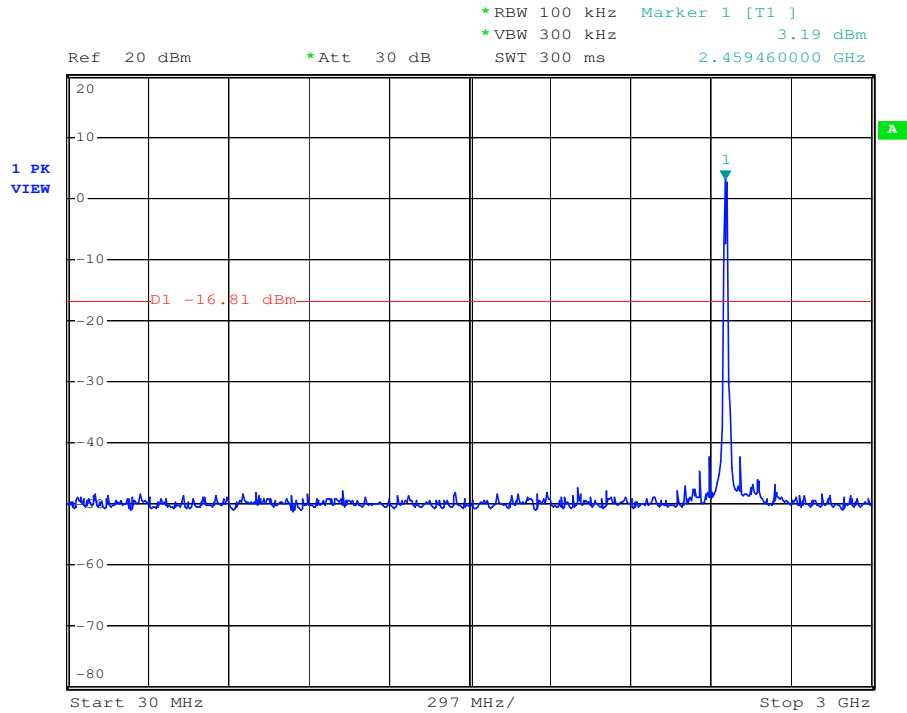

3GHz-25GHz:

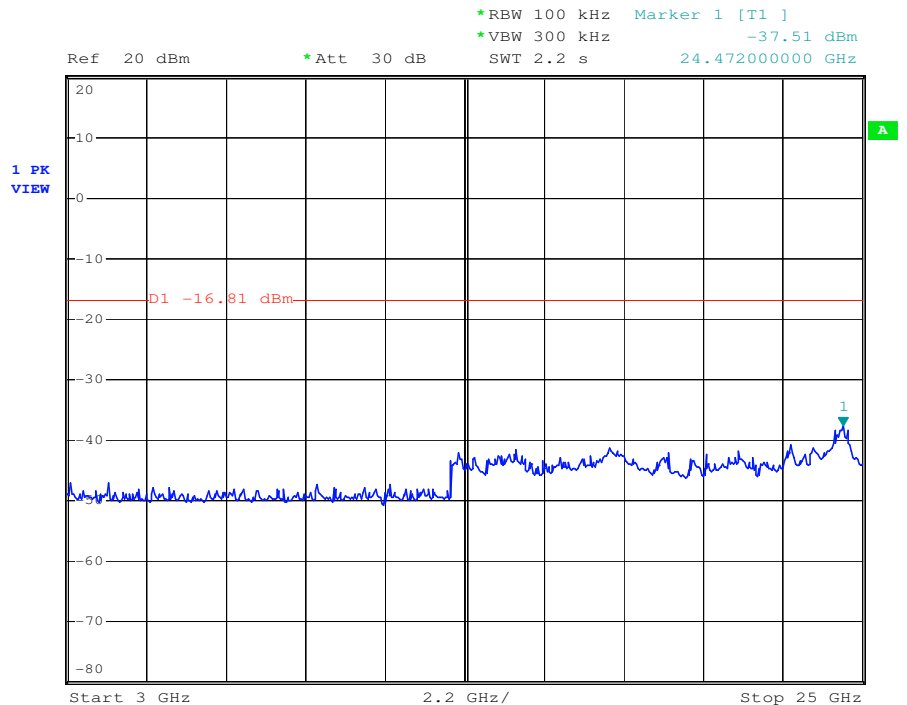

Test mode: 802.11g

Channel: Lowest

30MHz-3GHz:

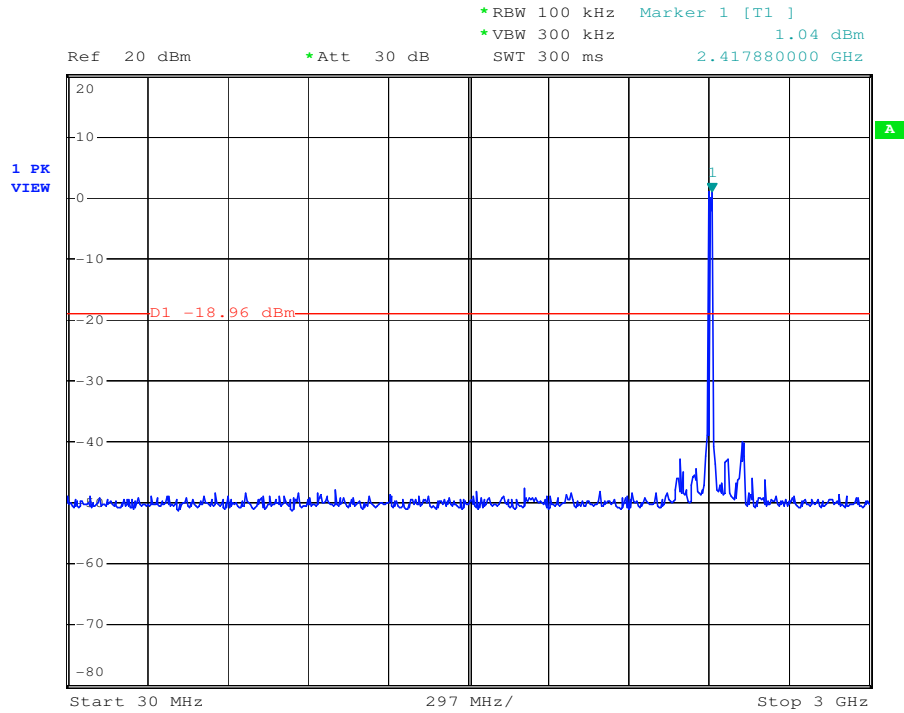

3GHz-25GHz:

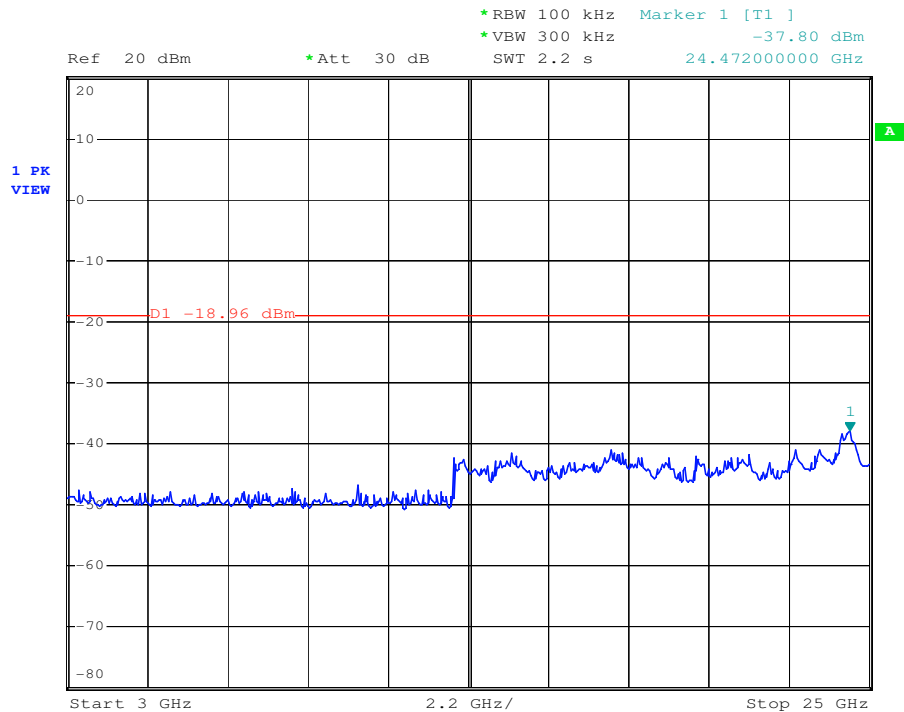

Test mode: 802.11g

Channel: Middle

30MHz-3GHz:

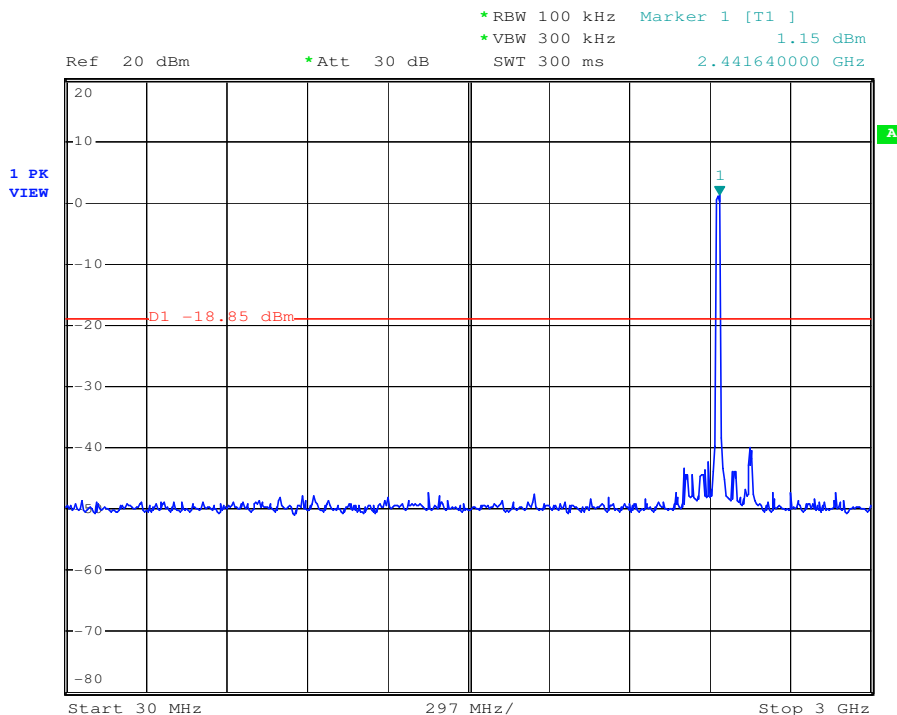

3GHz-25GHz:

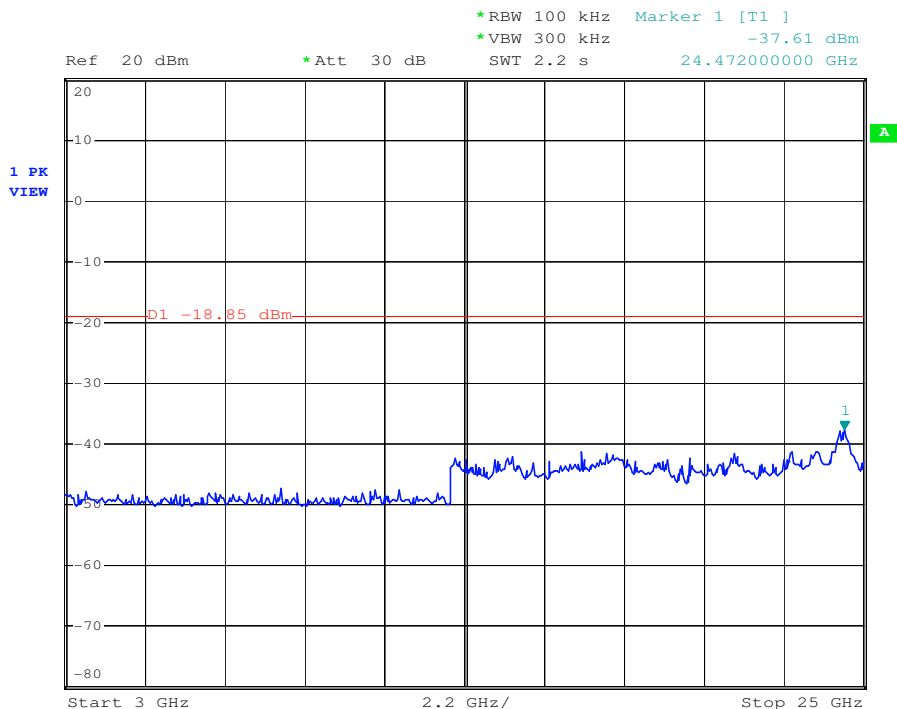

Test mode: 802.11g

Channel: Highest

30MHz-3GHz:

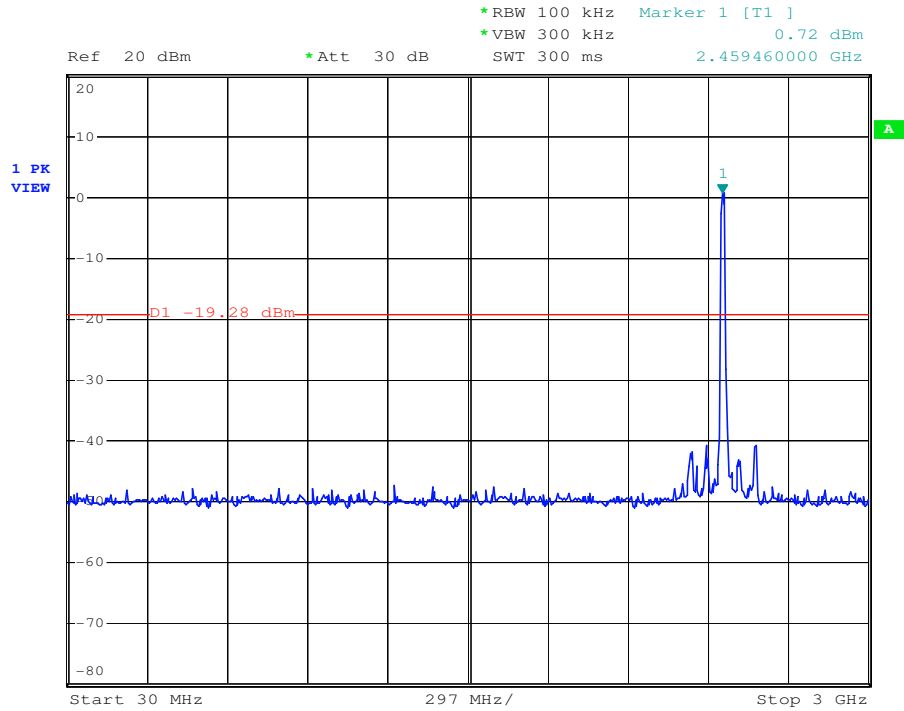

3GHz-25GHz:

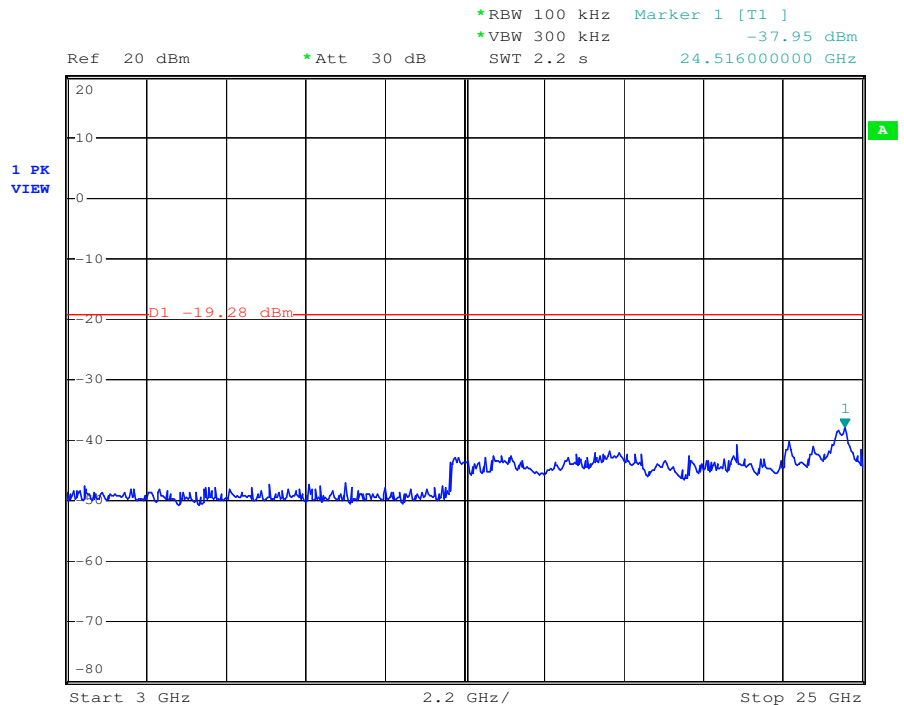

7.7.2 Conducted Band-edge

Test plot as follows:

Antenna A:

Test mode: 802.11b

Channel: Lowest

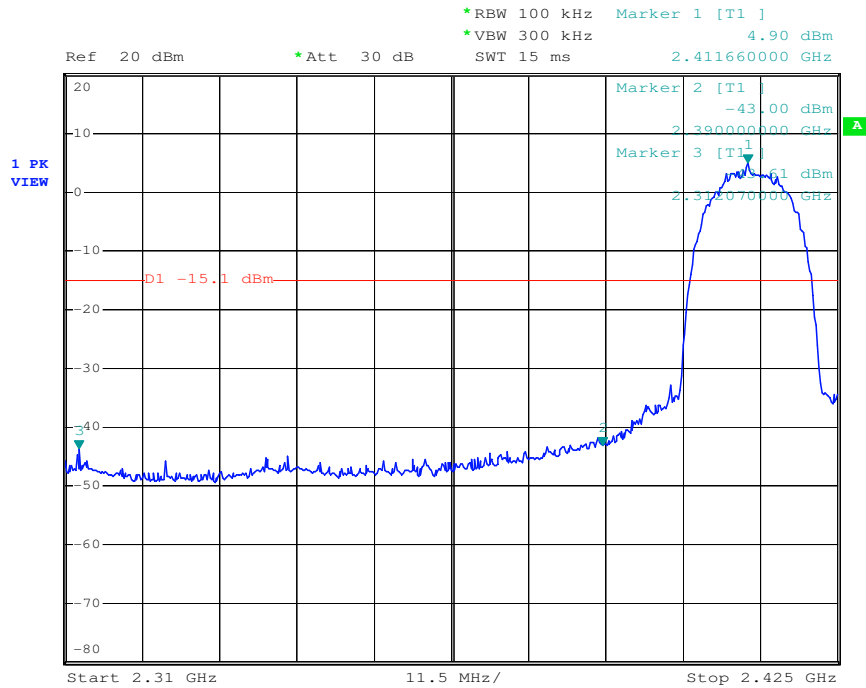

Test mode: 802.11b

Channel: Highest

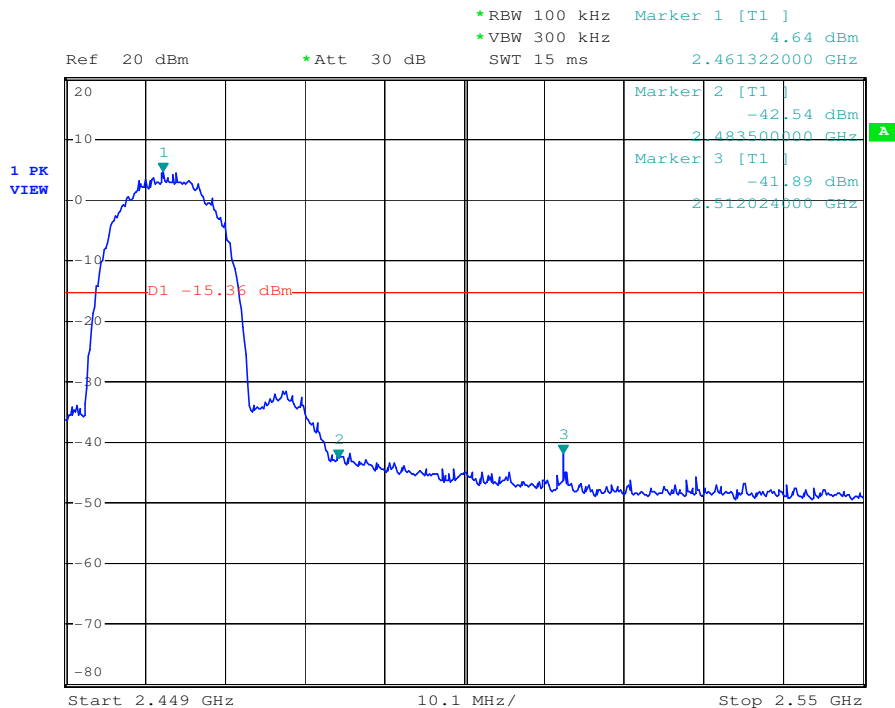

Test mode: 802.11g

Channel: Lowest

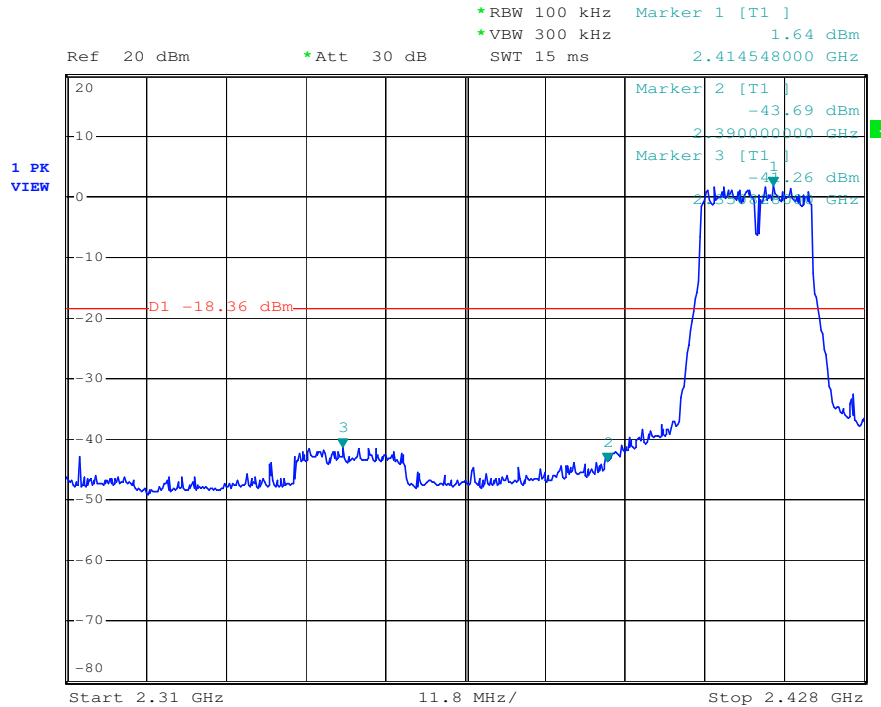

Test mode: 802.11g

Channel: Highest

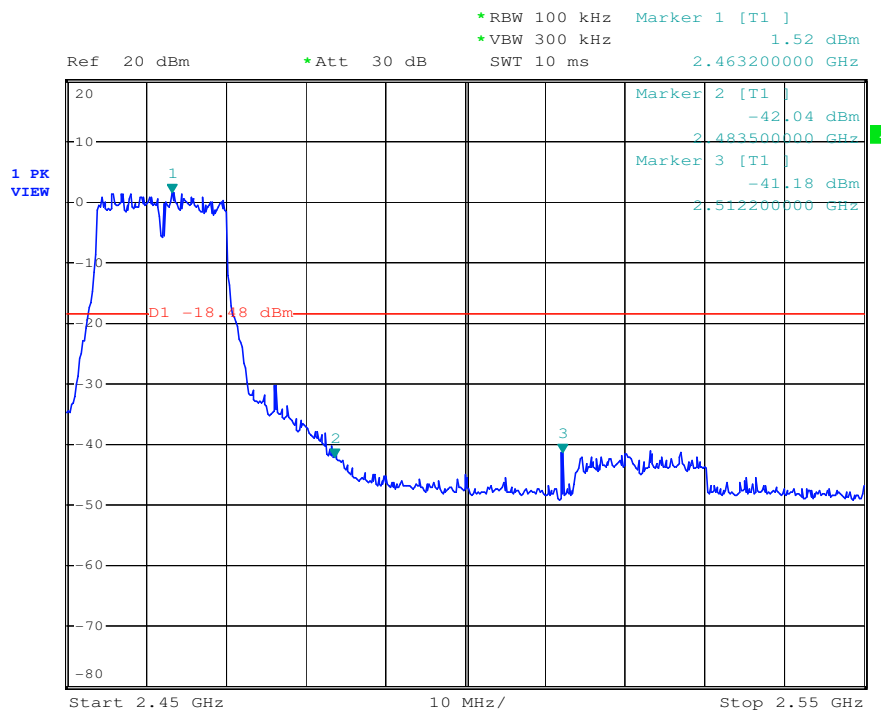

Antenna B:

Test mode: **802.11b**

Channel: **Lowest**

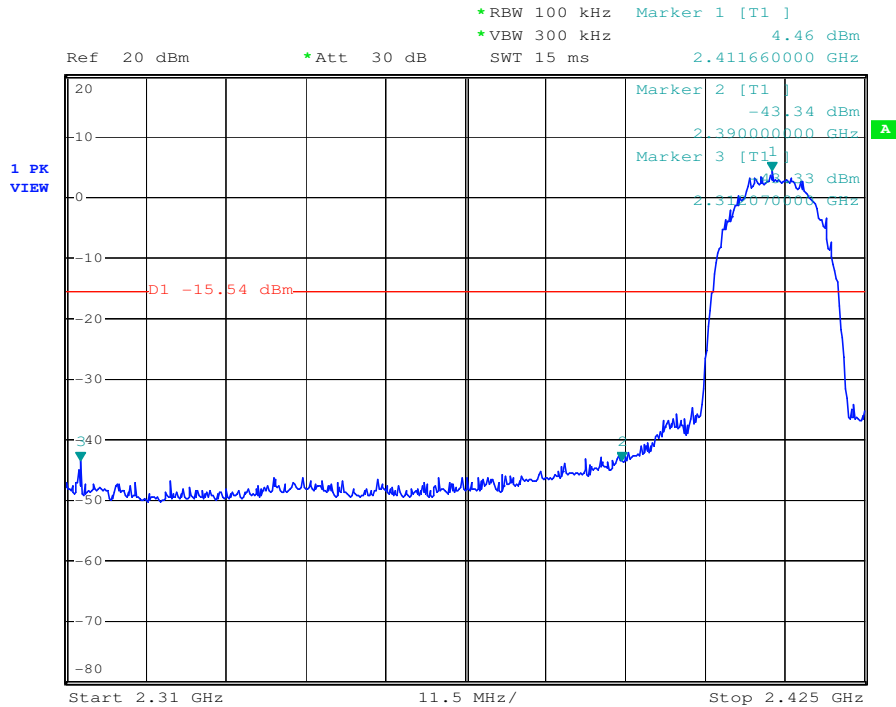

Test mode: **802.11b**

Channel: **Highest**

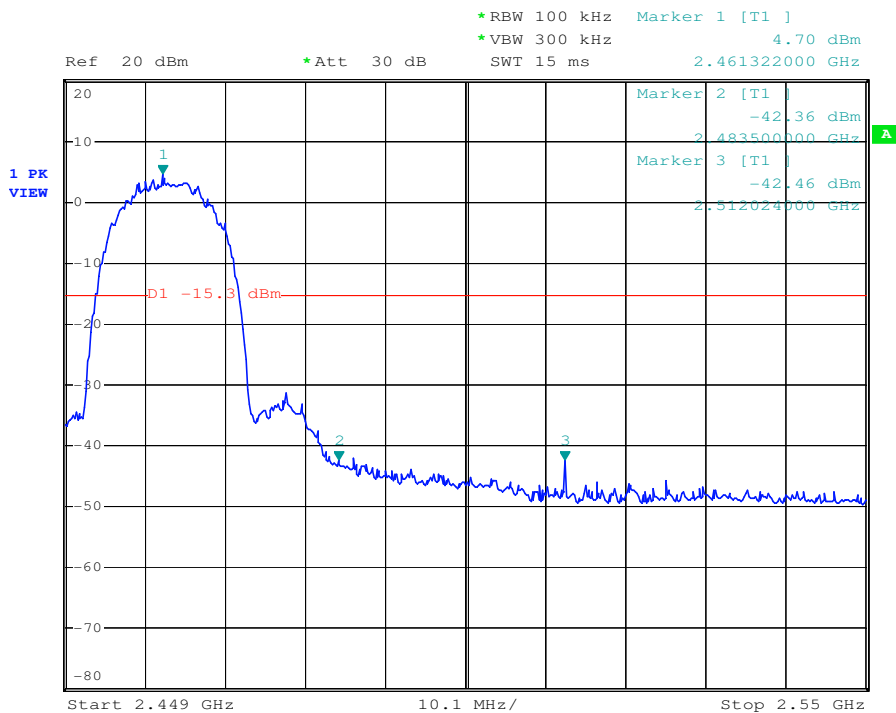

Test mode: 802.11g

Channel: Lowest

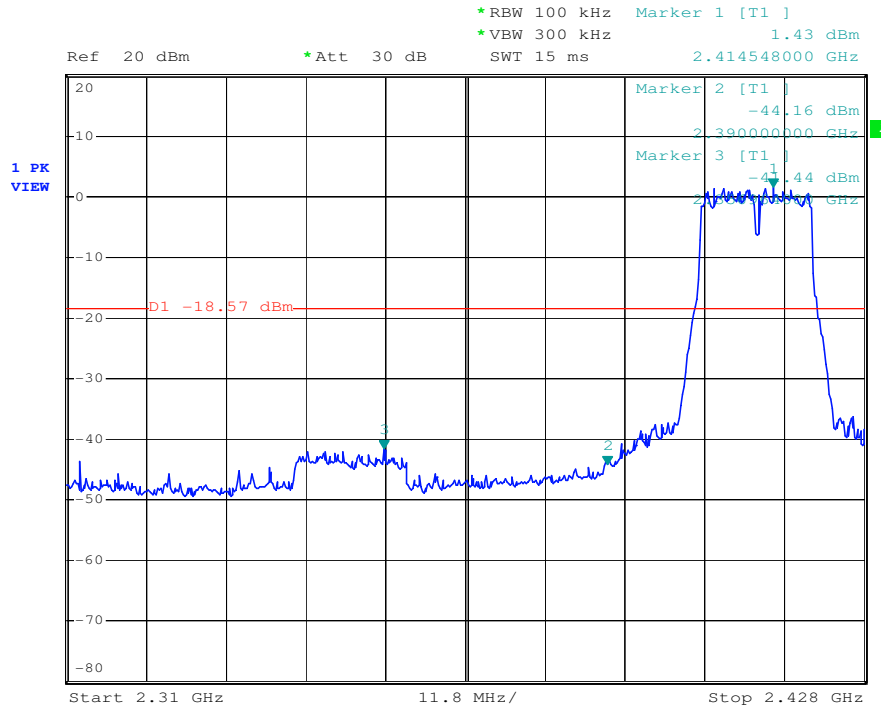

Test mode: 802.11g

Channel: Highest

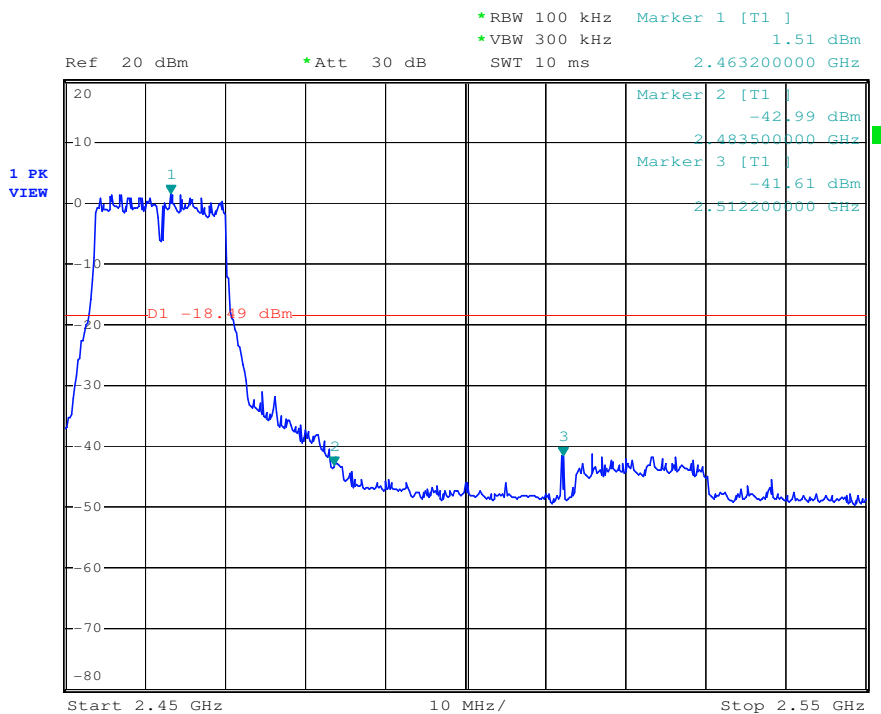

7.8 Radiated Spurious Emissions and Band-edge

Frequency Range: 9KHz to 25GHz

Test site/setup: Measurement Distance: 3m (Semi-Anechoic Chamber)
Test instrumentation set-up:

Frequency Range	Detector	RBW	VBW
0.009MHz-0.090MHz	Peak	10kHz	30kHz
0.009MHz-0.090MHz	Average	10kHz	30kHz
0.090MHz-0.110MHz	Quasi-peak	10kHz	30kHz
0.110MHz-0.490MHz	Peak	10kHz	30kHz
0.110MHz-0.490MHz	Average	10kHz	30kHz
0.490MHz -30MHz	Quasi-peak	10kHz	30kHz
30MHz-1GHz	Quasi-peak	100kHz	300kHz
Above 1GHz	Peak	RBW=1MHz	VBW≥RBW
	Average		VBW=10Hz

Sweep=Auto

15.209 Limit:

Frequency	Limit (dBuV/m)
0.009MHz-0.490MHz	128.5 ~ 93.8
0.490MHz-1.705MHz	73.8 ~63.0
1.705MHz-30MHz	69.5
30MHz-88MHz	40.0
88MHz-216MHz	43.5
216MHz-960MHz	46.0
960MHz-1GHz	54.0
Above 1GHz	54.0

Note: 15.35(b), Unless otherwise specified, the limit on peak radio frequency emissions is 20dB above the maximum permitted average emission limit applicable to the equipment under test. This peak limit applies to the total peak emission level radiated by the device.

Test Configuration:

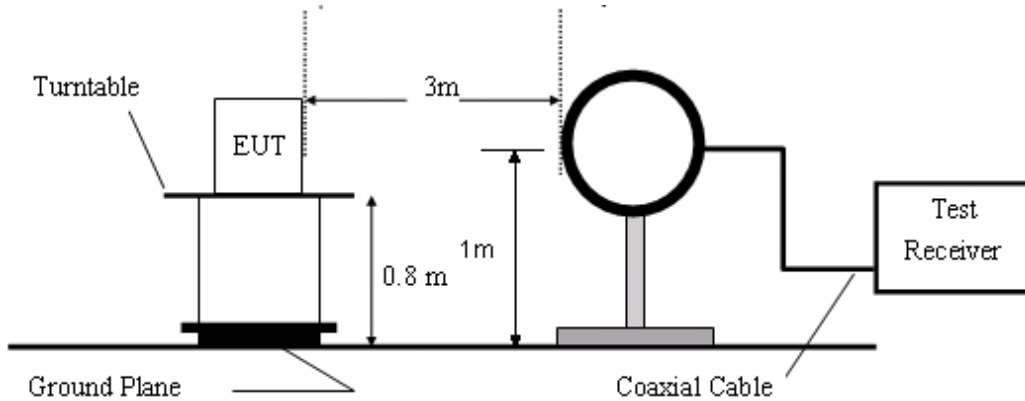

Figure1. Below 30MHz radiated emissions test configuration

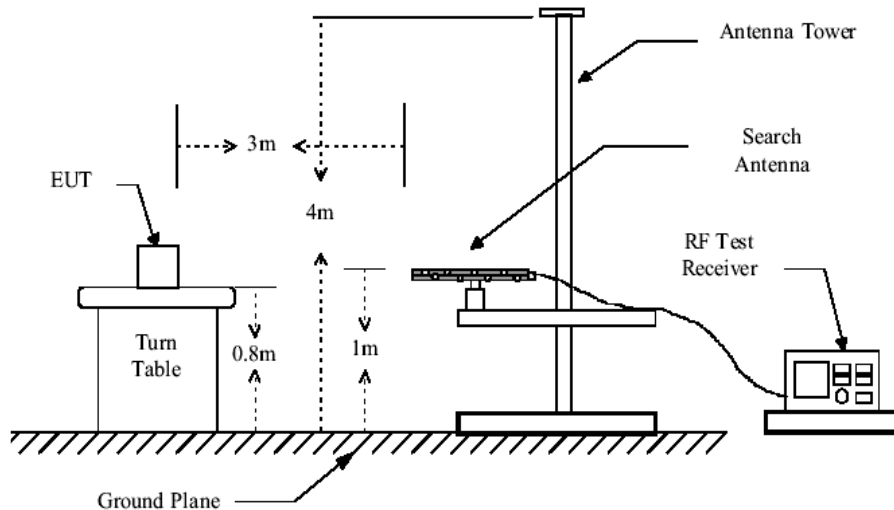

Figure2. 30MHz to 1GHz radiated emissions test configuration

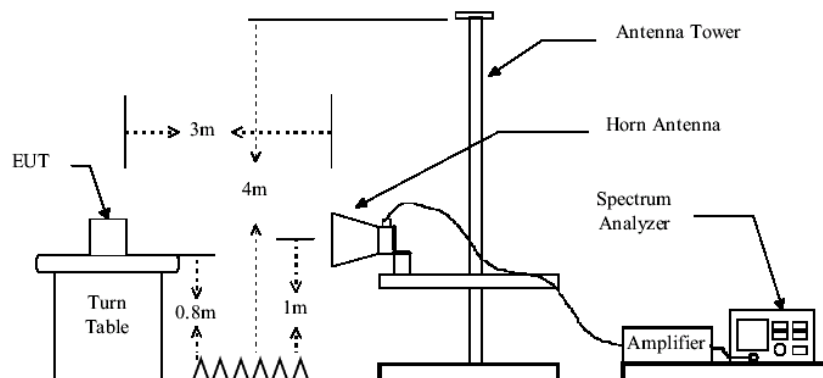

Figure3. Above 1GHz radiated emissions test configuration

Test Procedure: The procedure used was ANSI Standard C63.10:2009. The receiver was scanned from 9KHz to 25GHz. When an emission was found, the table was rotated to produce the maximum signal strength. An initial pre-scan was performed for in peak detection mode using the receiver. The EUT was measured for both the Horizontal and Vertical polarities and performed a pre-test three orthogonal planes. For intentional radiators, measurements of the variation of the input power or the radiated signal level of the fundamental frequency component of the emission, as appropriate, shall be performed with the supply voltage varied between 85% and 115% of the nominal rated supply voltage. The worst case emissions were reported.

Low noise amplifier was used below 1GHz, High pass Filter was used above 3GHz.

Between 1G and 3GHz, we did not use any amplifier or filter.

Pre-test was performed on Antenna A and Antenna B mode, Compliance test was performed on worse case (Antenna A mode).

Test were performed for their spatial orthogonal(X, Y, Z), the worst test data (X orthogonal) was submitted.

- 1) For this intentional radiator operates below 25 GHz. the spectrum shall be investigated to the tenth harmonic of the highest fundamental frequency. And above the third harmonic of this intentional radiator, the disturbance is very low. So the test result only displays to 5rd harmonic.
- 2) As shown in Section, for frequencies above 1000MHz. the above field strength limits are based on average limits. However, the peak field strength of any emission shall not exceed the maximum permitted average limits specified above by more than 20 dB under any condition of modulation.

The test only perform the EUT in transmitting status since the test frequencies were over 1GHz only required transmitting status.

Test Result: Pass

7.8.1 Radiated Spurious Emissions:

30MHz-1GHz:

Vertical:

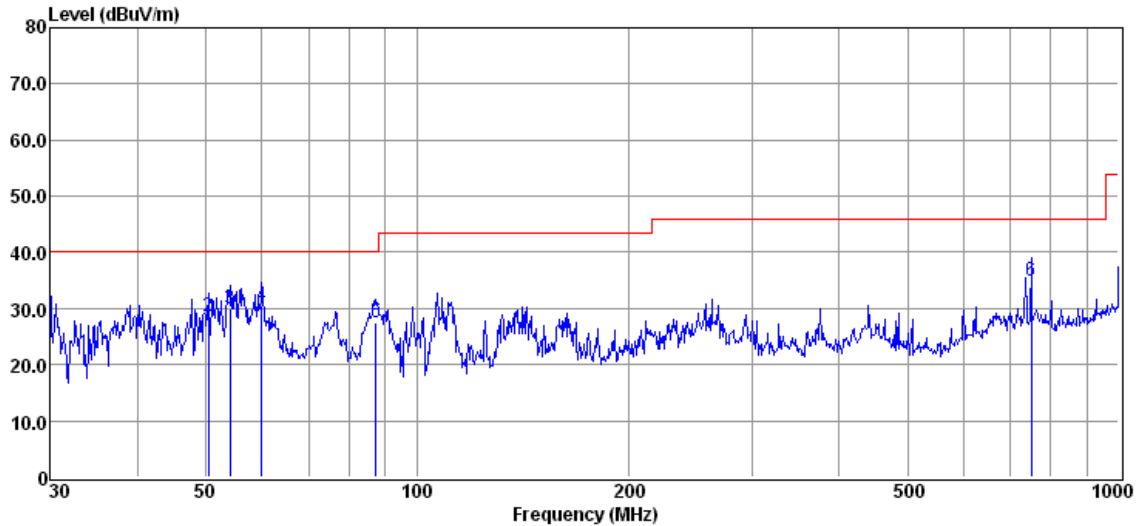

Item	Freq.	Read Level	Antenna Factor	Preamp Factor	Cable Loss	Result Level	Limit Line	Over Limit	Detector
(Mark)	(MHz)	(dBμV)	(dB/m)	(dB)	(dB)	(dBμV/m)	(dBμV/m)	(dB)	
1	30.000	45.61	12.50	23.72	0.55	34.94	40.00	-5.06	QP
2	50.409	39.27	12.65	23.69	0.42	28.65	40.00	-11.35	QP
3	54.071	40.96	12.21	23.69	0.47	29.95	40.00	-10.05	QP
4	60.069	41.63	12.10	23.68	0.53	30.58	40.00	-9.42	QP
5	87.418	41.98	8.45	23.67	0.79	27.55	40.00	-12.45	QP
6	750.108	34.65	21.20	23.90	3.08	35.03	46.00	-10.97	QP

Horizontal:

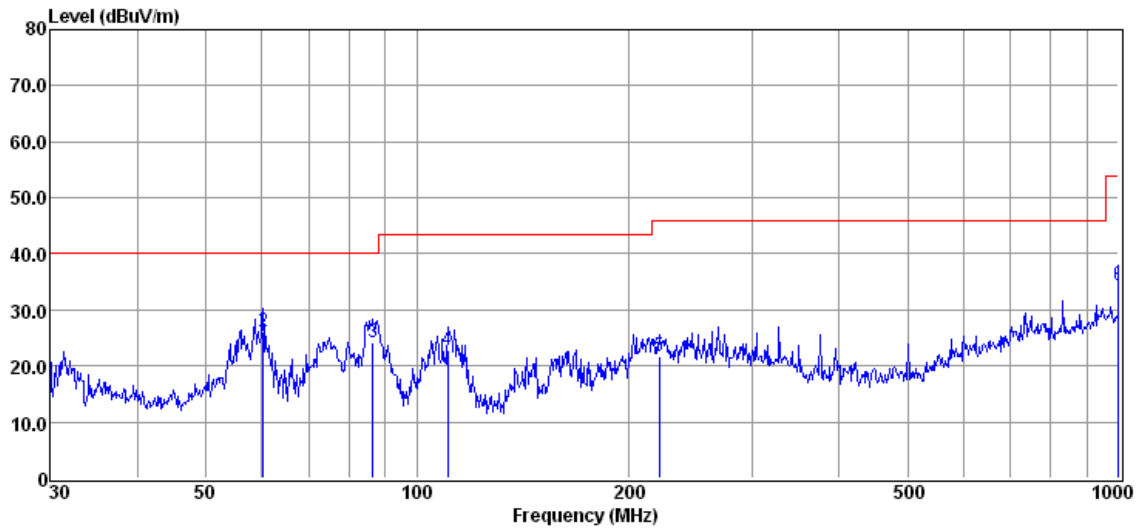

Item	Freq.	Read Level	Antenna Factor	Preamp Factor	Cable Loss	Result Level	Limit Line	Over Limit	Detector
(Mark)	(MHz)	(dBµV)	(dB/m)	(dB)	(dB)	(dBµV/m)	(dBµV/m)	(dB)	
1	30.000	32.51	12.50	23.72	0.55	21.84	40.00	-18.16	QP
2	60.280	37.31	12.07	23.68	0.53	26.23	40.00	-13.77	QP
3	86.503	38.60	8.51	23.67	0.77	24.21	40.00	-15.79	QP
4	110.569	34.98	10.57	23.65	0.98	22.88	43.50	-20.62	QP
5	221.392	34.75	9.05	23.63	1.46	21.63	46.00	-24.37	QP
6	1000.000	30.02	24.50	23.94	3.71	34.29	54.00	-19.71	QP

Above 1GHz:

Antenna A Test mode: 802.11b Channel: lowest

Mark	Frequency (MHz)	Reading (dBuV)	Factor (dB)	Emission (dBuV/m)	Limit (dBuV/m)	Over Limit (dB)	Detector	Polarization
1	4842.25	40.49	5.88	46.34	74	-27.66	peak	Horizontal
2	7239.05	39.90	9.62	49.52	74	-24.48	peak	Horizontal
3	9636.22	40.80	13.51	54.30	74	-19.70	peak	Horizontal
4	9636.22	22.13	13.51	35.64	54	-18.36	AV	Horizontal
5	4842.25	43.51	5.88	49.38	74	-24.62	peak	Vertical
6	7239.23	43.07	9.62	52.69	74	-21.31	peak	Vertical
7	9636.25	42.39	13.51	55.91	74	-18.09	peak	Vertical
8	9636.25	21.74	13.51	35.25	54	-18.75	AV	Vertical

Antenna A Test mode: 802.11b Channel: Middle

Mark	Frequency (MHz)	Reading (dBuV)	Factor (dB)	Emission (dBuV/m)	Limit (dBuV/m)	Over Limit (dB)	Detector	Polarization
1	4877.10	41.29	6.10	47.41	74	-26.59	peak	Horizontal
2	7320.50	41.58	9.79	51.37	74	-22.63	peak	Horizontal
3	9765.50	40.24	13.54	53.78	74	-20.22	peak	Horizontal
4	4877.20	43.58	6.10	49.69	74	-24.31	peak	Vertical
5	7321.30	43.99	9.79	53.75	74	-20.25	peak	Vertical
6	9765.50	43.06	13.54	56.61	74	-17.39	peak	Vertical
7	9765.50	22.41	13.54	35.95	54	-18.05	AV	Vertical

Antenna A Test mode: 802.11b Channel: Highest

Mark	Frequency (MHz)	Reading (dBuV)	Factor (dB)	Emission (dBuV/m)	Limit (dBuV/m)	Over Limit (dB)	Detector	Polarization
1	4935.15	41.67	6.22	47.88	74	-26.12	peak	Horizontal
2	7403.75	41.81	10.04	51.83	74	-22.17	peak	Horizontal
3	9847.50	39.96	13.59	53.51	74	-20.49	peak	Horizontal
4	4936.25	43.72	6.22	49.95	74	-24.05	peak	Vertical
5	7403.55	45.15	10.04	55.21	74	-18.79	peak	Vertical
6	7403.55	25.80	10.04	35.84	54	-18.16	AV	Vertical
7	9847.75	43.08	13.59	56.64	74	-17.36	peak	Vertical
8	9847.75	25.58	13.59	36.17	54	-17.83	AV	Vertical

Antenna A Test mode: 802.11g Channel: lowest

Mark	Frequency (MHz)	Reading (dBuV)	Factor (dB)	Emission (dBuV/m)	Limit (dBuV/m)	Over Limit (dB)	Detector	Polarization
1	4827.50	41.93	5.79	47.71	74	-26.29	peak	Horizontal
2	7245.50	42.12	9.63	51.67	74	-22.33	peak	Horizontal
3	9652.50	39.83	13.50	53.31	74	-20.69	peak	Horizontal
4	4827.50	44.16	5.79	49.95	74	-24.05	peak	Vertical
5	7245.50	43.80	9.63	53.43	74	-20.57	peak	Vertical
6	9652.50	42.42	13.5	55.92	74	-18.08	peak	Vertical
7	9652.50	21.98	13.5	35.48	54	-18.52	AV	Vertical

Antenna A Test mode: 802.11g Channel: Middle

Mark	Frequency (MHz)	Reading (dBuV)	Factor (dB)	Emission (dBuV/m)	Limit (dBuV/m)	Over Limit (dB)	Detector	Polarization
1	4857.50	41.16	5.98	47.18	74	-26.82	peak	Horizontal
2	7291.50	39.79	9.72	49.53	74	-24.47	peak	Horizontal
3	9740.50	40.96	13.53	54.48	74	-19.52	peak	Horizontal
4	9740.50	21.38	13.53	34.91	54	-19.09	AV	Horizontal
5	4857.50	44.90	5.98	50.85	74	-23.15	peak	Vertical
6	7292.20	43.17	9.72	52.83	74	-21.17	peak	Vertical
7	9740.40	43.27	13.53	56.78	74	-17.22	peak	Vertical
8	9740.40	22.05	13.53	35.58	54	-18.42	AV	Vertical

Antenna A Test mode: 802.11g Channel: Highest

Mark	Frequency (MHz)	Reading (dBuV)	Factor (dB)	Emission (dBuV/m)	Limit (dBuV/m)	Over Limit (dB)	Detector	Polarization
1	4942.50	41.88	6.20	48.05	74	-25.95	peak	Horizontal
2	7375.20	43.16	9.97	53.14	74	-20.86	peak	Horizontal
3	9864.20	40.67	13.60	54.24	74	-19.76	peak	Horizontal
4	9864.20	19.68	13.60	33.28	54	-20.72	AV	Horizontal
5	4942.50	44.84	6.20	51.03	74	-22.97	peak	Vertical
6	7375.50	45.97	9.97	55.91	74	-18.09	peak	Vertical
7	7375.50	24.50	9.97	34.47	54	-19.53	AV	Vertical
8	9863.20	43.54	13.60	57.15	74	-16.85	peak	Vertical
9	9863.20	22.12	13.60	35.72	54	-18.28	AV	Vertical

Antenna B			Test mode: 802.11b			Channel: lowest		
Mark	Frequency (MHz)	Reading (dBuV)	Factor (dB)	Emission (dBuV/m)	Limit (dBuV/m)	Over Limit (dB)	Detector	Polarization
1	4829.60	42.80	5.80	48.66	74	-25.34	peak	Horizontal
2	7226.70	43.19	9.6	52.82	74	-21.18	peak	Horizontal
3	9625.10	42.37	13.5	55.84	74	-18.16	peak	Horizontal
4	9625.10	21.27	13.5	34.77	54	-18.16	AV	Horizontal
5	4829.50	42.78	5.8	48.57	74	-25.43	peak	Vertical
6	7227.10	42.11	9.6	51.78	74	-22.22	peak	Vertical
7	9624.70	41.68	13.5	55.21	74	-18.79	peak	Vertical
8	9624.70	21.86	13.5	35.36	54	-18.79	AV	Vertical

Antenna B			Test mode: 802.11b			Channel: Middle		
Mark	Frequency (MHz)	Reading (dBuV)	Factor (dB)	Emission (dBuV/m)	Limit (dBuV/m)	Over Limit (dB)	Detector	Polarization
1	4865.75	43.04	6.03	49.13	74	-24.87	peak	Horizontal
2	7333.25	43.69	9.83	53.53	74	-20.47	peak	Horizontal
3	9730.25	43.59	13.53	57.17	74	-16.83	peak	Horizontal
4	9730.25	23.32	13.53	36.85	54	-17.15	AV	Horizontal
5	4865.75	42.52	6.03	48.57	74	-25.43	peak	Vertical
6	7333.25	42.83	9.83	52.64	74	-21.36	peak	Vertical
7	9730.25	41.43	13.53	54.92	74	-19.08	peak	Vertical
8	9730.25	21.50	13.53	35.03	54	-18.93	AV	Vertical

Antenna B			Test mode: 802.11b			Channel: Highest		
Mark	Frequency (MHz)	Reading (dBuV)	Factor (dB)	Emission (dBuV/m)	Limit (dBuV/m)	Over Limit (dB)	Detector	Polarization
1	4912.75	43.97	6.23	50.23	74	-23.77	peak	Horizontal
2	7380.25	44.93	9.98	54.94	74	-19.06	peak	Horizontal
3	7380.25	25.69	9.98	35.67	54	-18.33	AV	Horizontal
4	9859.25	43.43	13.60	57.06	74	-16.94	peak	Horizontal
5	9859.25	23.12	13.60	36.72	54	-17.28	AV	Horizontal
6	4912.73	42.91	6.23	49.14	74	-24.86	peak	Vertical
7	7380.19	44.75	9.98	54.73	74	-19.27	peak	Vertical
8	7380.19	26.23	9.98	36.21	54	-17.79	AV	Vertical
9	9859.25	42.74	13.60	56.34	74	-17.66	peak	Vertical
10	9859.25	22.95	13.60	36.55	54	-17.45	AV	Vertical

Antenna B Test mode: 802.11g Channel: lowest

Mark	Frequency (MHz)	Reading (dBuV)	Factor (dB)	Emission (dBuV/m)	Limit (dBuV/m)	Over Limit (dB)	Detector	Polarization
1	4818.75	44.61	5.74	50.34	74	-23.66	peak	Horizontal
2	7262.55	43.03	9.66	52.68	74	-21.32	peak	Horizontal
3	9659.75	42.12	13.50	55.65	74	-18.35	peak	Horizontal
4	9659.75	22.73	13.50	36.27	54	-17.73	AV	Horizontal
5	4818.75	43.34	5.74	49.13	74	-24.87	peak	Vertical
6	7262.55	42.21	9.66	51.85	74	-22.15	peak	Vertical
7	9659.75	42.42	13.5	55.94	74	-18.06	peak	Vertical
8	9659.75	21.95	13.5	35.05	54	-18.95	AV	Vertical

Antenna B Test mode: 802.11g Channel: Middle

Mark	Frequency (MHz)	Reading (dBuV)	Factor (dB)	Emission (dBuV/m)	Limit (dBuV/m)	Over Limit (dB)	Detector	Polarization
1	4887.85	42.85	6.17	49.13	74	-24.87	peak	Horizontal
2	7309.55	43.26	9.76	53.04	74	-20.96	peak	Horizontal
3	9753.75	42.83	13.53	56.37	74	-17.63	peak	Horizontal
4	9753.75	23.31	13.53	36.84	54	-17.16	AV	Horizontal
5	4887.85	42.17	6.17	48.37	74	-25.63	peak	Vertical
6	7309.55	42.84	9.76	52.62	74	-21.38	peak	Vertical
7	9753.75	42.53	13.53	56.05	74	-17.95	peak	Vertical
8	9753.75	22.43	13.53	35.96	54	-18.04	AV	Vertical

Antenna B Test mode: 802.11g Channel: Highest

Mark	Frequency (MHz)	Reading (dBuV)	Factor (dB)	Emission (dBuV/m)	Limit (dBuV/m)	Over Limit (dB)	Detector	Polarization
1	4924.50	44.03	6.21	50.26	74	-23.74	peak	Horizontal
2	7368.50	44.64	9.93	54.64	74	-19.36	peak	Horizontal
3	7368.50	25.92	9.93	35.85	54	-18.15	AV	Horizontal
4	9824.50	43.15	13.57	56.75	74	-17.25	peak	Horizontal
5	9824.50	22.27	13.57	35.84	54	-18.16	AV	Horizontal
6	4924.50	43.75	6.21	49.91	74	-24.09	peak	Vertical
7	7368.50	44.42	9.93	54.34	74	-19.66	peak	Vertical
8	7368.50	25.86	9.93	35.79	54	-18.21	AV	Vertical
9	9824.50	43.11	13.57	56.65	74	-17.35	peak	Vertical
10	9824.50	22.62	13.57	36.19	54	-17.81	AV	Vertical

Remark: 1. Test Level =Receiver Reading + Antenna Factor + Cable Loss –Preamplifier Factor.

This document is issued by the Company subject to its General Conditions of Service printed overleaf, available on request or accessible at www.sgs.com/terms_and_conditions.htm and, for electronic format documents, subject to Terms and Conditions for Electronic Documents at www.sgs.com/terms_e_document.htm. Attention is drawn to the limitation of liability, indemnification and jurisdiction issues defined therein. Any holder of this document is advised that information contained hereon reflects the Company's findings at the time of its intervention only and within the limits of Client's instructions, if any. The Company's sole responsibility is to its Client and this document does not exonerate parties to a transaction from exercising all their rights and obligations under the transaction documents. This document cannot be reproduced except in full, without prior written approval of the Company. Any unauthorized alteration, forgery or falsification of the content or appearance of this document is unlawful and offenders may be prosecuted to the fullest extent of the law. Unless otherwise stated the results shown in this test report refer only to the sample(s) tested and such sample(s) are retained for 90 days only

2. No any other emissions level which are attenuated less than 20dB below the limit. According to 15.31(o), the amplitude of spurious emissions from intentional radiators and emissions from unintentional radiators which are attenuated more than 20 dB below the permissible value need not be reported unless specifically required elsewhere in this Part. Hence there no other emissions have been reported.
3. If the Peak value below the AV Limit, the AV test doesn't perform for this submission.

7.8.2 Radiated Band edge

Antenna A:

Test Mode: 802.11b

Channel: lowest

MK.	Frequency (MHz)	Reading (dBuV/m)	Corrected factor(dB)	Result (dBuV/m)	Limit (dBuV/m)	Over Limit (dB)	Detector	Polarization
1	2390.00	52.76	-3.95	48.81	74	-25.19	Peak	Horizontal
2	2412.00	99.73	-4.09	95.64	74	21.64	Peak	Horizontal
1	2390.00	48.53	-3.95	44.58	74	-29.42	Peak	Vertical
2	2412.00	100.4	-4.09	96.31	74	22.31	Peak	Vertical

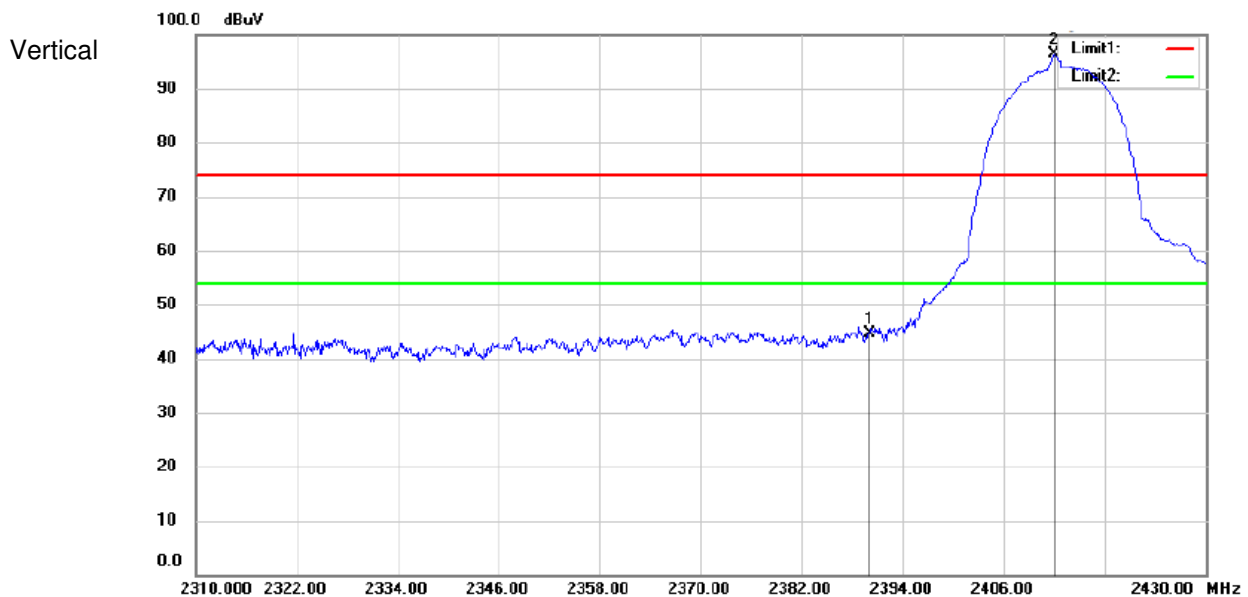
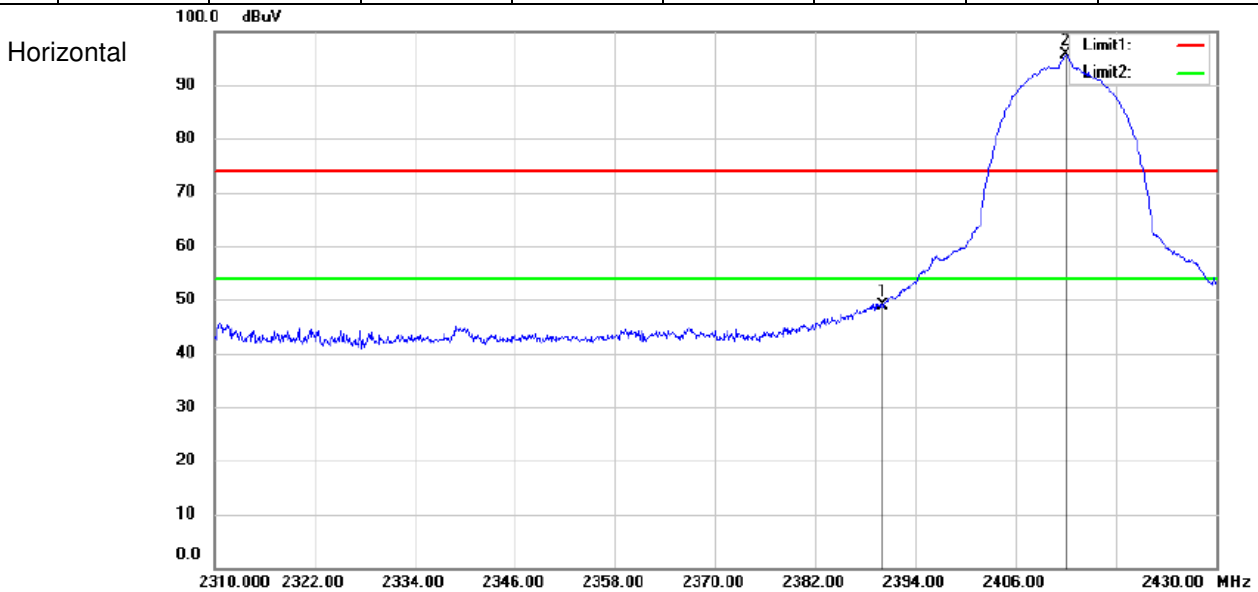

Test Mode: 802.11b

Channel: Highest

MK.	Frequency (MHz)	Reading (dBUV/m)	Corrected factor(dB)	Result (dBUV/m)	Limit (dBUV/m)	Over Limit (dB)	Detector	Polarization
1	2462.00	102.33	-4.4	97.93	74	23.93	Peak	Horizontal
2	2483.50	65.89	-4.53	61.36	74	-12.64	Peak	Horizontal
1	2462.00	90.27	-4.40	85.87	54	31.87	Average	Horizontal
2	2483.50	34.65	-4.53	30.12	54	-23.88	Average	Horizontal
3	2512.00	39.17	-4.52	34.65	54	-19.35	Average	Horizontal

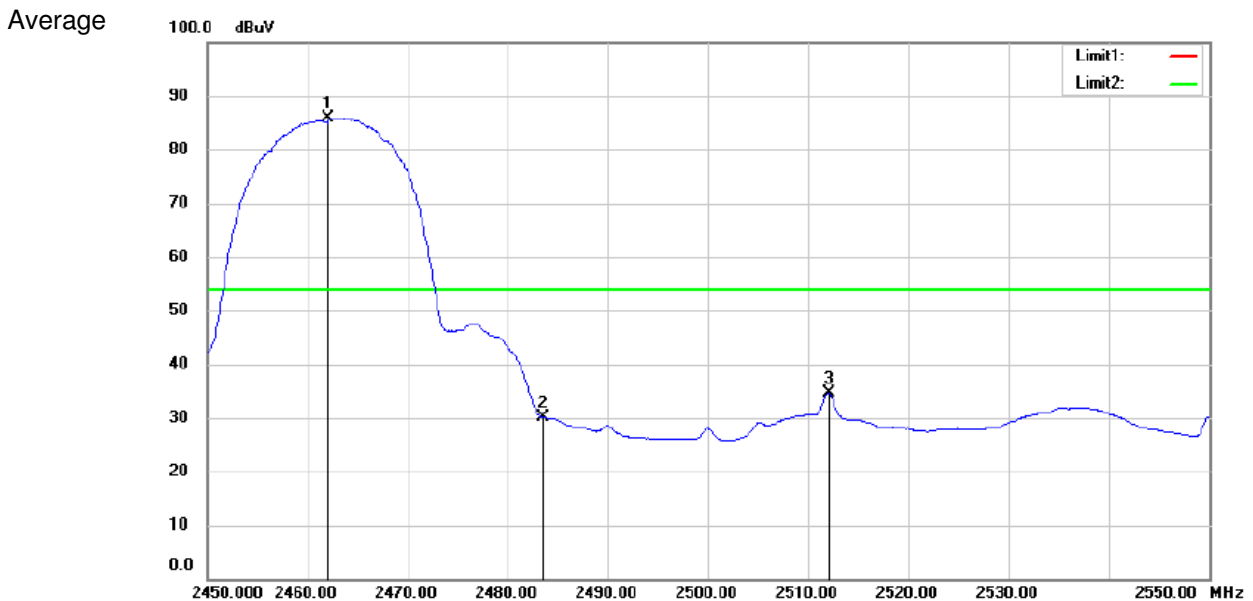
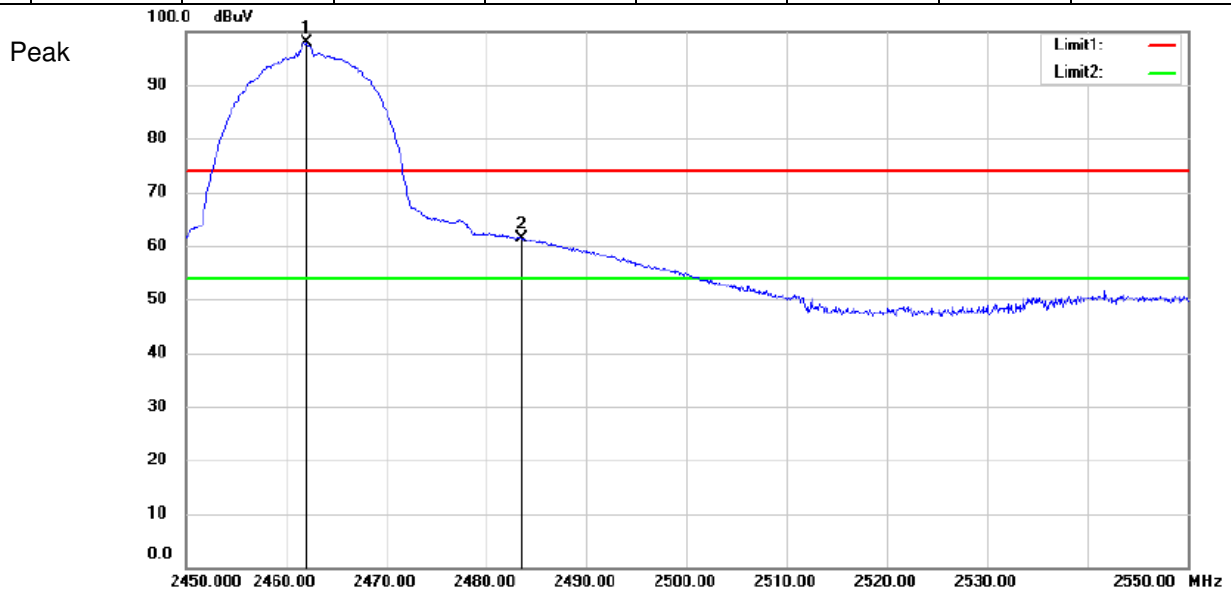

Test Mode: 802.11b

Channel: Highest

MK.	Frequency (MHz)	Reading (dBuV/m)	Corrected factor(dB)	Result (dBuV/m)	Limit (dBuV/m)	Over Limit (dB)	Detector	Polarization
1	2462.00	102.88	-4.40	98.48	74	24.48	Peak	Vertical
2	2483.50	64.03	-4.53	59.50	74	-14.50	Peak	Vertical
1	2462.00	90.66	-4.40	86.26	54	32.26	Average	Vertical
2	2483.50	33.46	-4.53	28.93	54	-25.07	Average	Vertical
3	2512.00	44.66	-4.52	40.14	54	-13.86	Average	Vertical

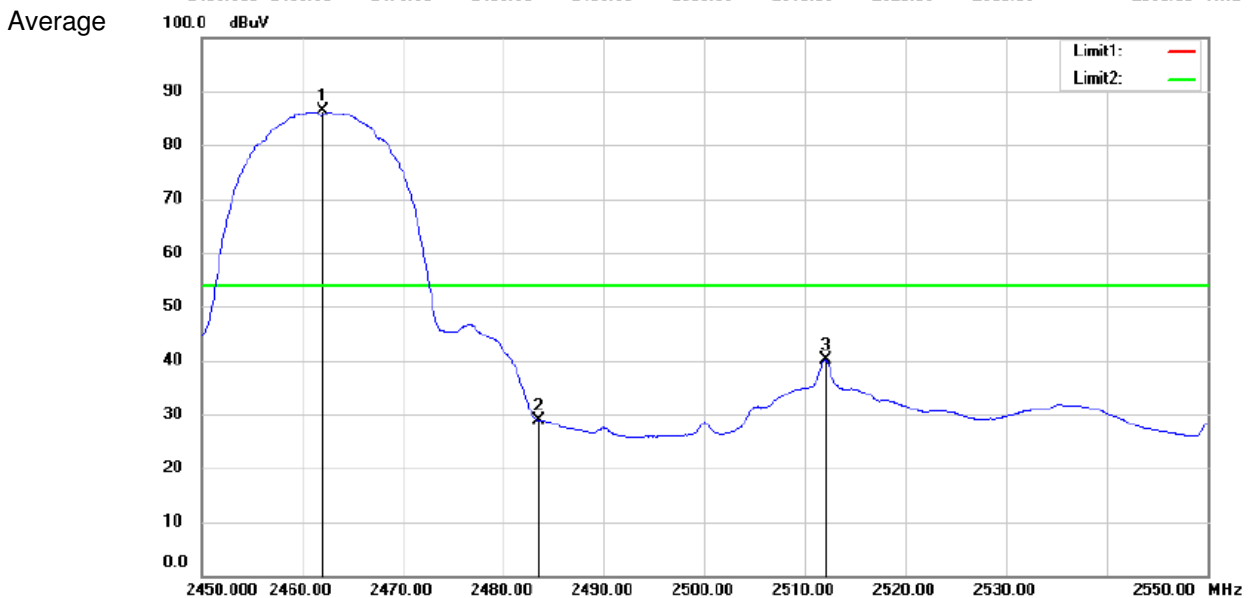
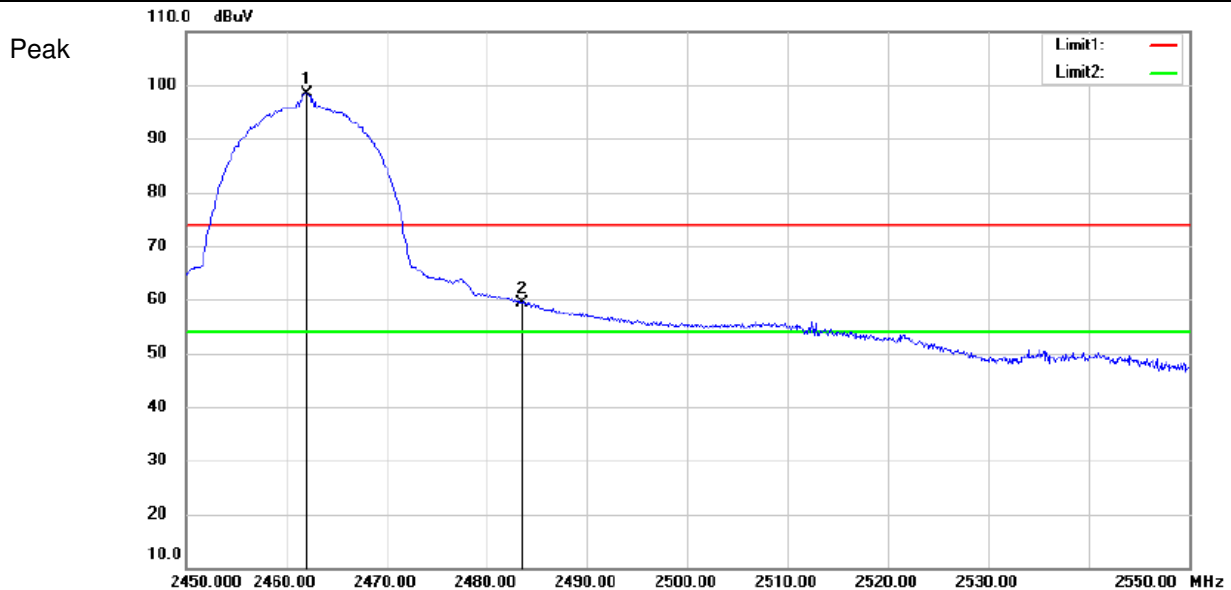

Test Mode: 802.11g

Channel: lowest

MK.	Frequency (MHz)	Reading (dBuV/m)	Corrected factor(dB)	Result (dBuV/m)	Limit (dBuV/m)	Over Limit (dB)	Detector	Polarization
1	2390.00	53.23	-3.95	49.28	74	-24.72	Peak	Horizontal
2	2416.00	101.93	-4.11	97.82	74	23.82	Peak	Horizontal
1	2390.00	50.39	-3.95	46.44	74	-27.56	Peak	Vertical
2	2416.00	99.61	-4.11	95.50	74	21.50	Peak	Vertical

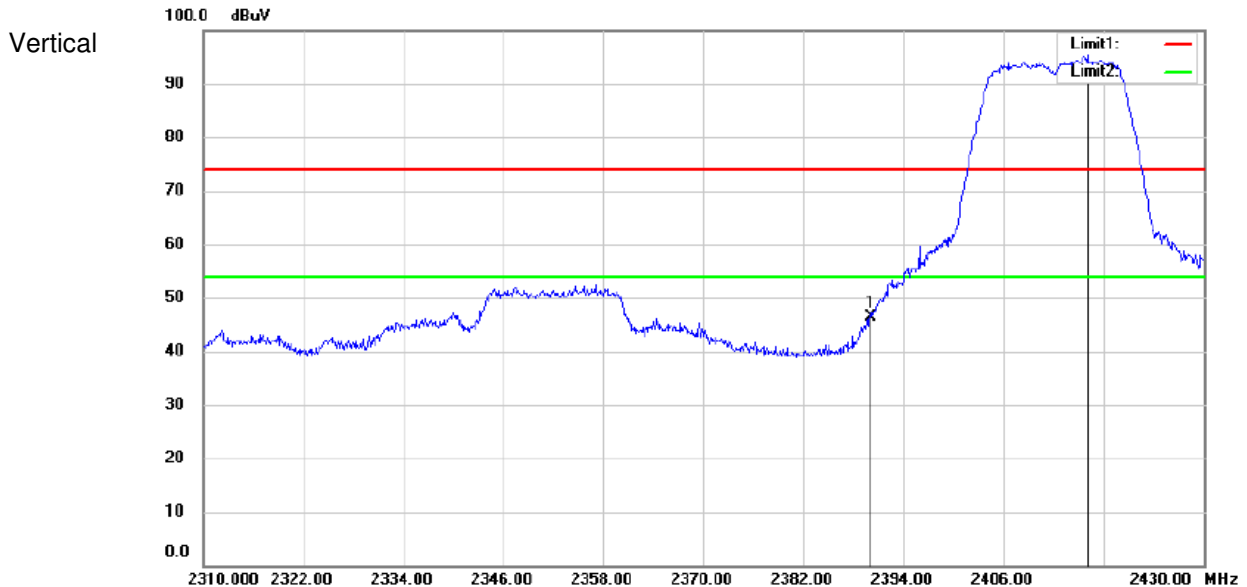
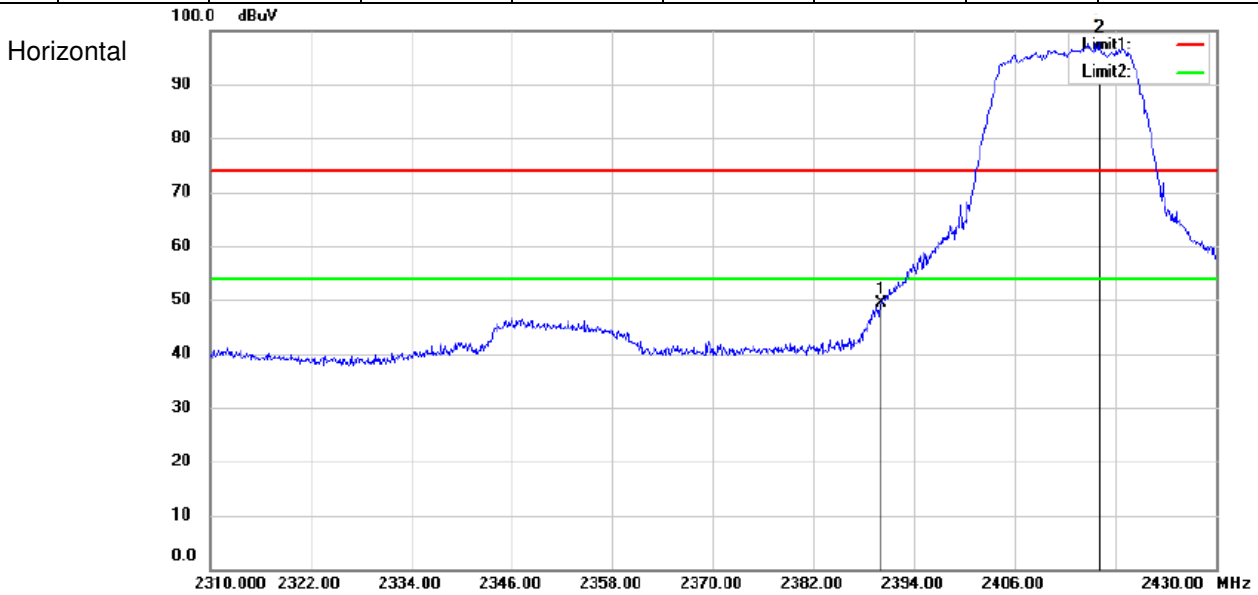

Test Mode: 802.11g

Channel: Highest

MK.	Frequency (MHz)	Reading (dBUV/m)	Corrected factor(dB)	Result (dBUV/m)	Limit (dBUV/m)	Over Limit (dB)	Detector	Polarization
1	2465.70	101.80	-4.42	97.38	74	23.38	Peak	Horizontal
2	2483.50	59.47	-4.53	54.94	74	-19.06	Peak	Horizontal
1	2460.10	72.19	-4.39	67.80	54	13.80	Average	Horizontal
2	2483.50	36.30	-4.53	31.77	54	-22.23	Average	Horizontal

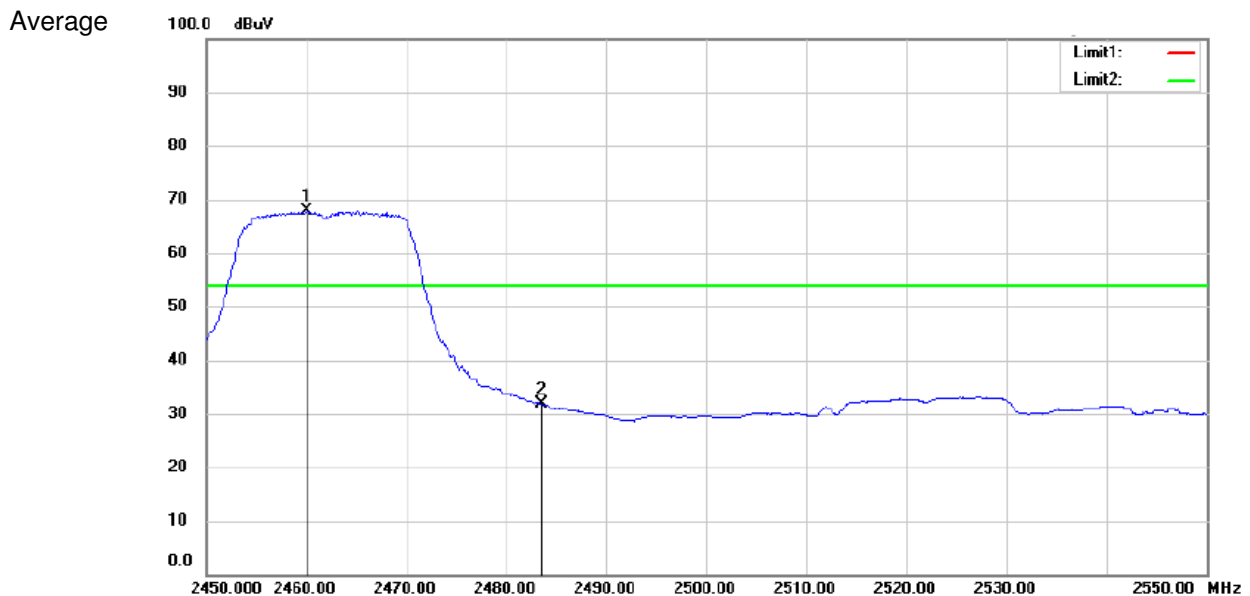
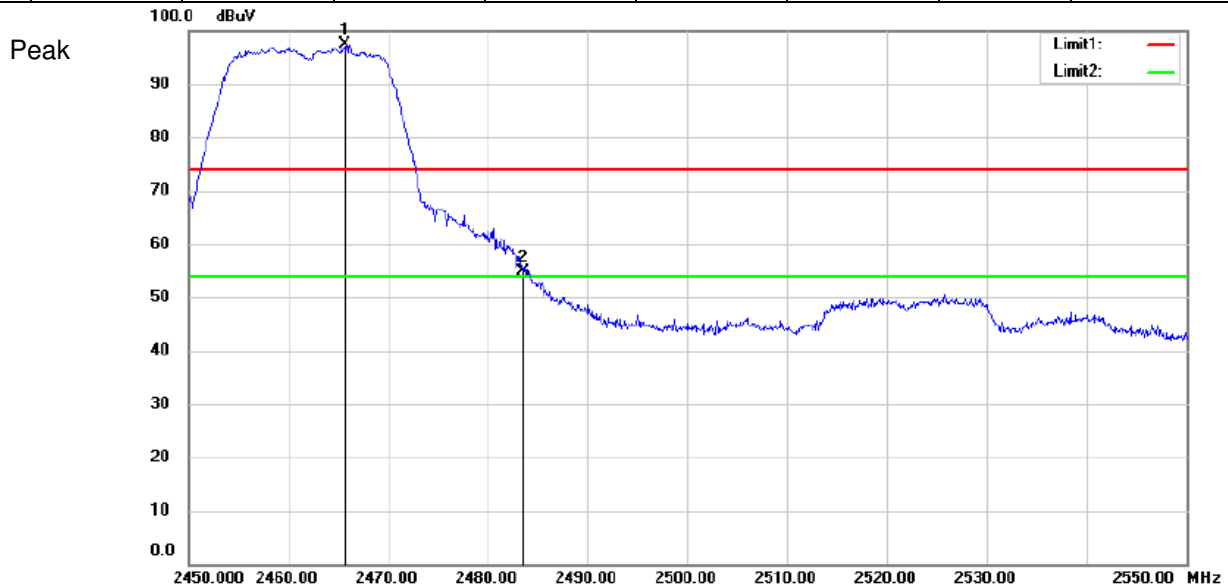

Test Mode: 802.11g

Channel: Highest

MK.	Frequency (MHz)	Reading (dBuV/m)	Corrected factor(dB)	Result (dBuV/m)	Limit (dBuV/m)	Over Limit (dB)	Detector	Polarization
1	2466.00	100.61	-4.43	96.18	74	22.18	Peak	Vertical
2	2483.50	58.94	-4.53	54.41	74	-19.59	Peak	Vertical
1	2460.00	71.89	-4.39	67.50	54	13.50	Average	Vertical
2	2483.50	36.38	-4.53	31.85	54	-22.15	Average	Vertical

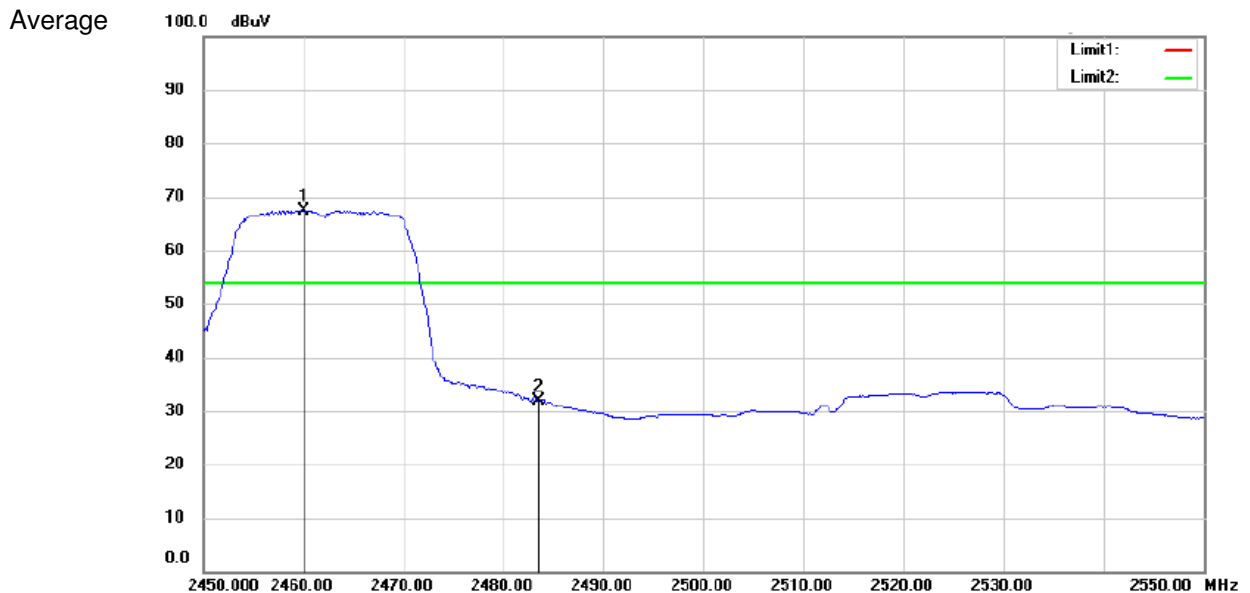
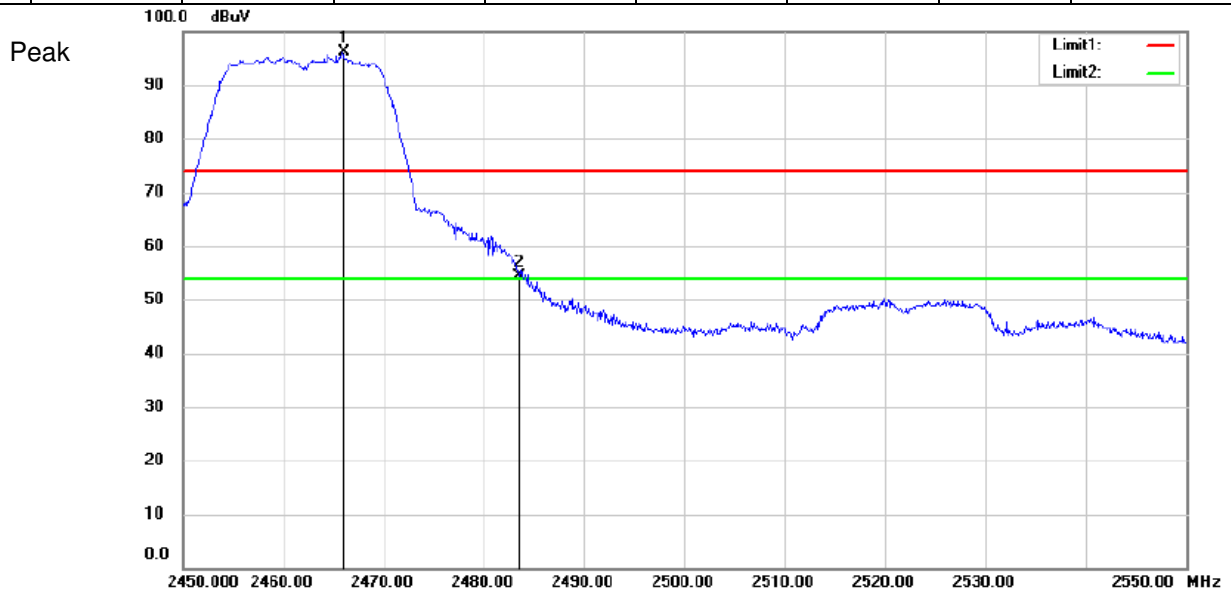

Antenna B:

Test Mode: 802.11b

Channel: lowest

MK.	Frequency (MHz)	Reading (dBUV/m)	Corrected factor(dB)	Result (dBUV/m)	Limit (dBUV/m)	Over Limit (dB)	Detector	Polarization
1	2390.00	47.57	-3.95	43.62	74	-30.38	Peak	Horizontal
2	2400.00	56.73	-4.01	52.72	74	-21.28	Peak	Horizontal
3	2412.00	98.94	-4.09	94.85	74	20.85	Peak	Horizontal
1	2390.00	48.00	-3.95	44.05	74	-29.95	Peak	Vertical
2	2400.00	57.51	-4.01	53.50	74	-20.50	Peak	Vertical
3	2412.00	97.69	-4.09	93.60	74	19.60	Peak	Vertical

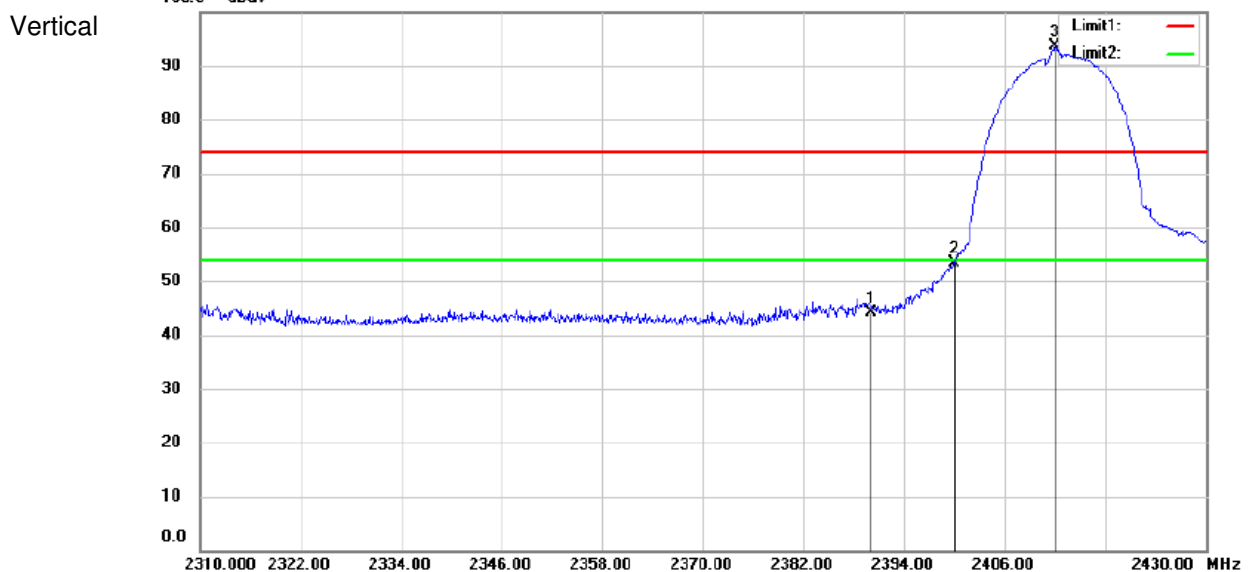
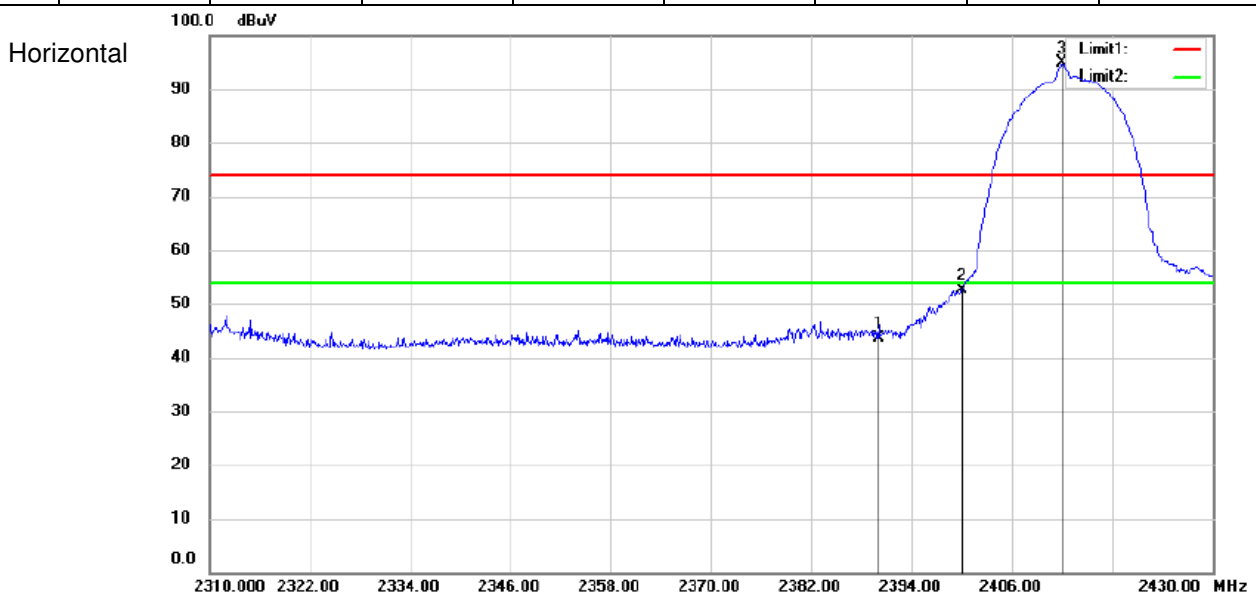

Test Mode: 802.11b

Channel: Highest

MK.	Frequency (MHz)	Reading (dBUV/m)	Corrected factor(dB)	Result (dBUV/m)	Limit (dBUV/m)	Over Limit (dB)	Detector	Polarization
1	2462.00	101.20	-4.40	96.80	74	22.80	Peak	Horizontal
2	2483.50	63.48	-4.53	58.95	74	-15.05	Peak	Horizontal
1	2462.60	89.16	-4.40	84.76	54	30.76	Average	Horizontal
2	2483.50	33.67	-4.53	29.14	54	-24.86	Average	Horizontal
3	2512.00	46.21	-4.52	41.69	54	-12.31	Average	Horizontal

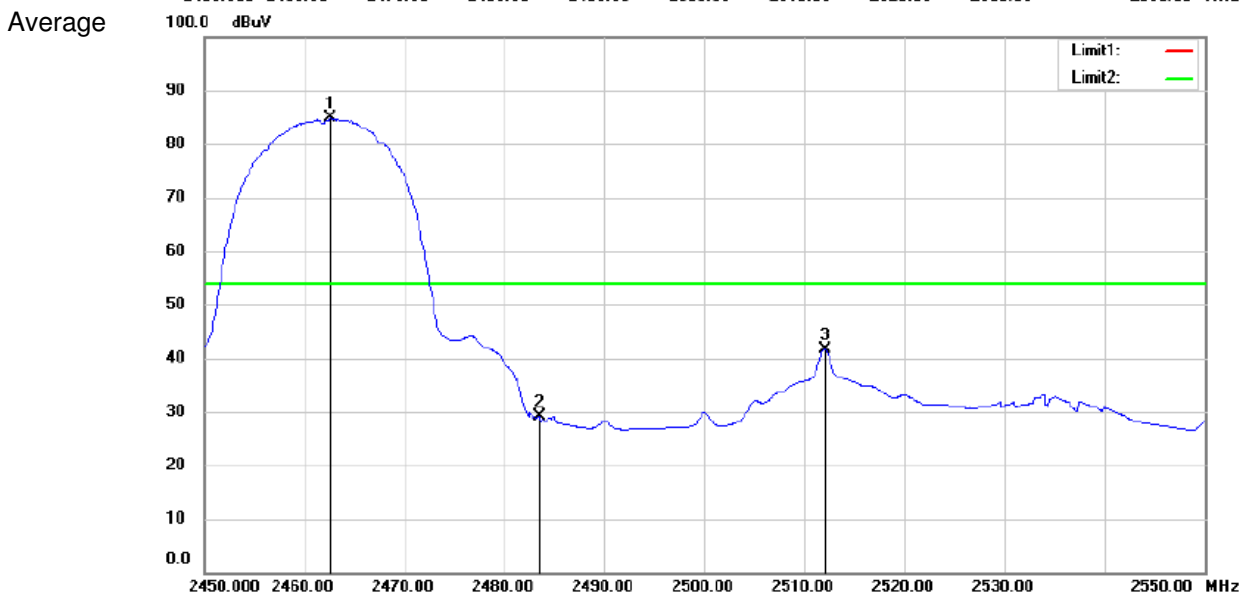
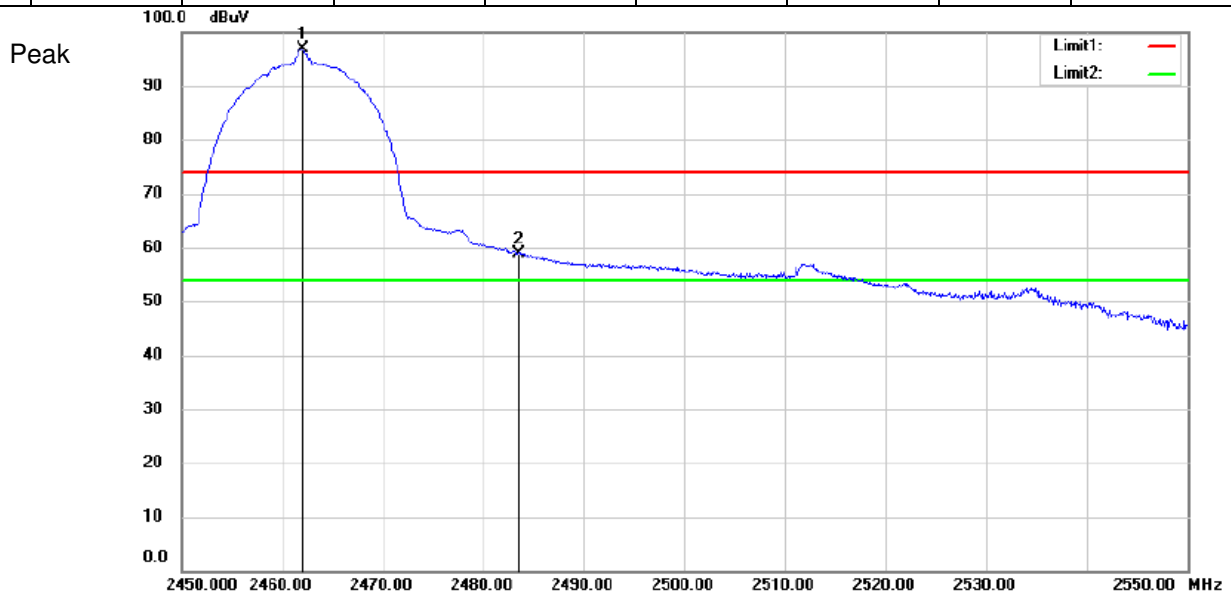

Test Mode: 802.11b

Channel: Highest

MK.	Frequency (MHz)	Reading (dBuV/m)	Corrected factor(dB)	Result (dBuV/m)	Limit (dBuV/m)	Over Limit (dB)	Detector	Polarization
1	2462.00	102.04	-4.40	97.64	74	23.64	Peak	Vertical
2	2483.50	62.34	-4.53	57.81	74	-16.19	Peak	Vertical
1	2462.00	90.01	-4.40	85.61	54	31.61	Average	Vertical
2	2483.50	32.66	-4.53	28.13	54	-25.87	Average	Vertical
3	2512.30	39.25	-4.51	34.74	54	-19.26	Average	Vertical

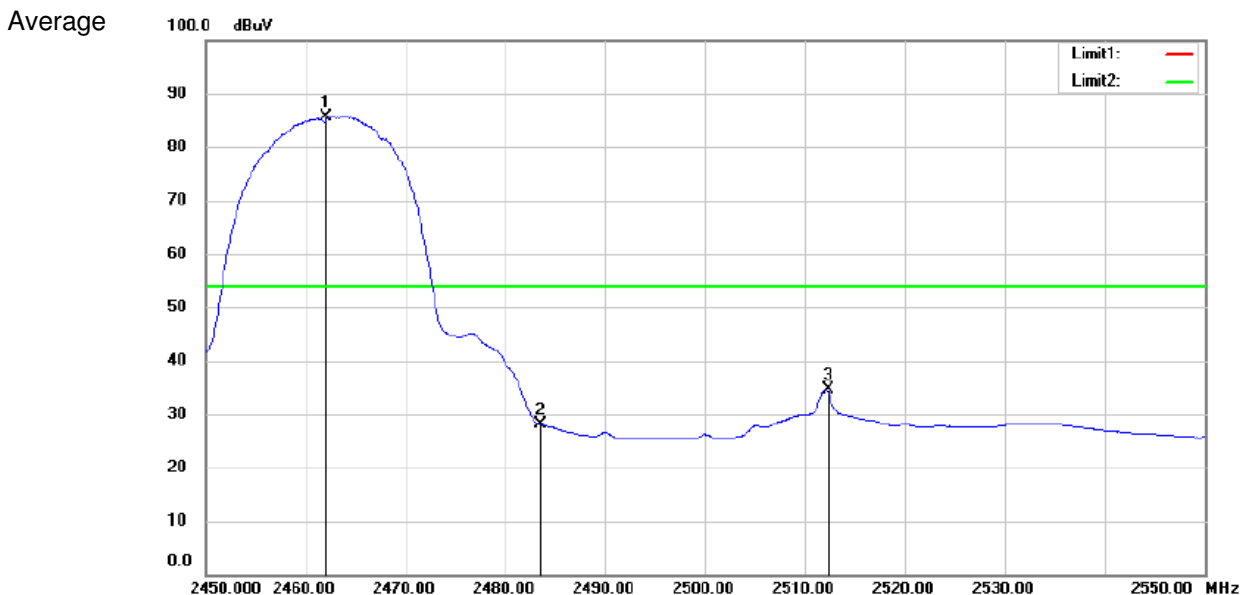
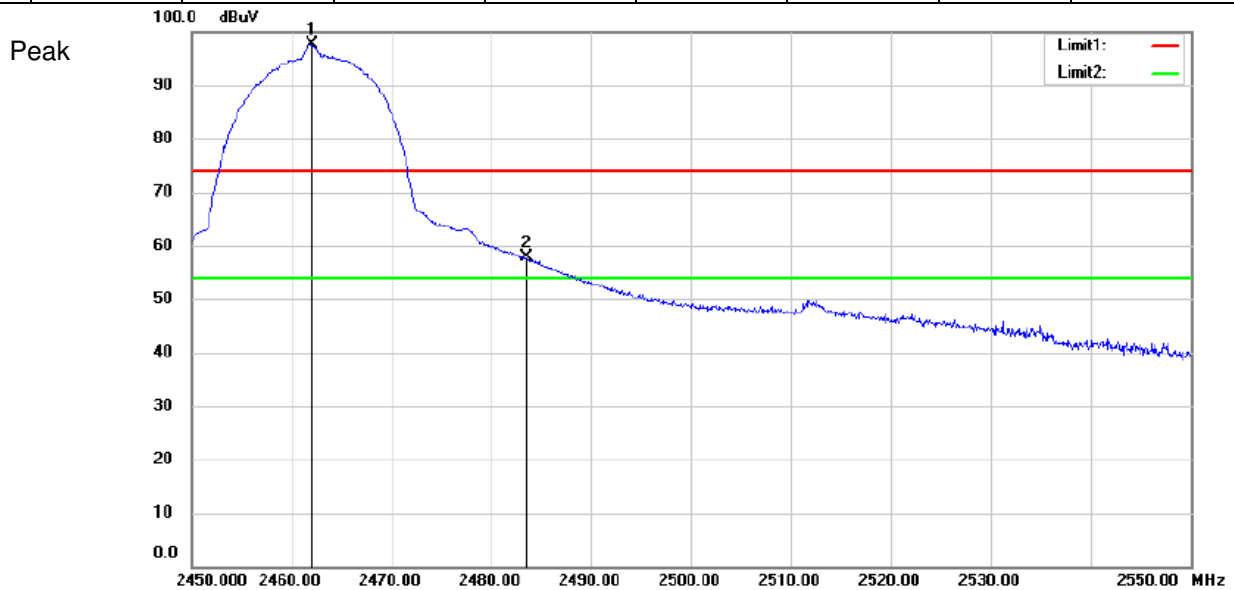

Test Mode: 802.11g

Channel: lowest

MK.	Frequency (MHz)	Reading (dBuV/m)	Corrected factor(dB)	Result (dBuV/m)	Limit (dBuV/m)	Over Limit (dB)	Detector	Polarization
1	2390.00	54.60	-3.95	50.65	74	-23.35	Peak	Horizontal
2	2415.81	100.72	-4.11	96.61	74	22.61	Peak	Horizontal
1	2390.00	54.17	-3.95	50.22	74	-23.78	Peak	Vertical
2	2407.90	100.47	-4.06	96.41	74	22.41	Peak	Vertical

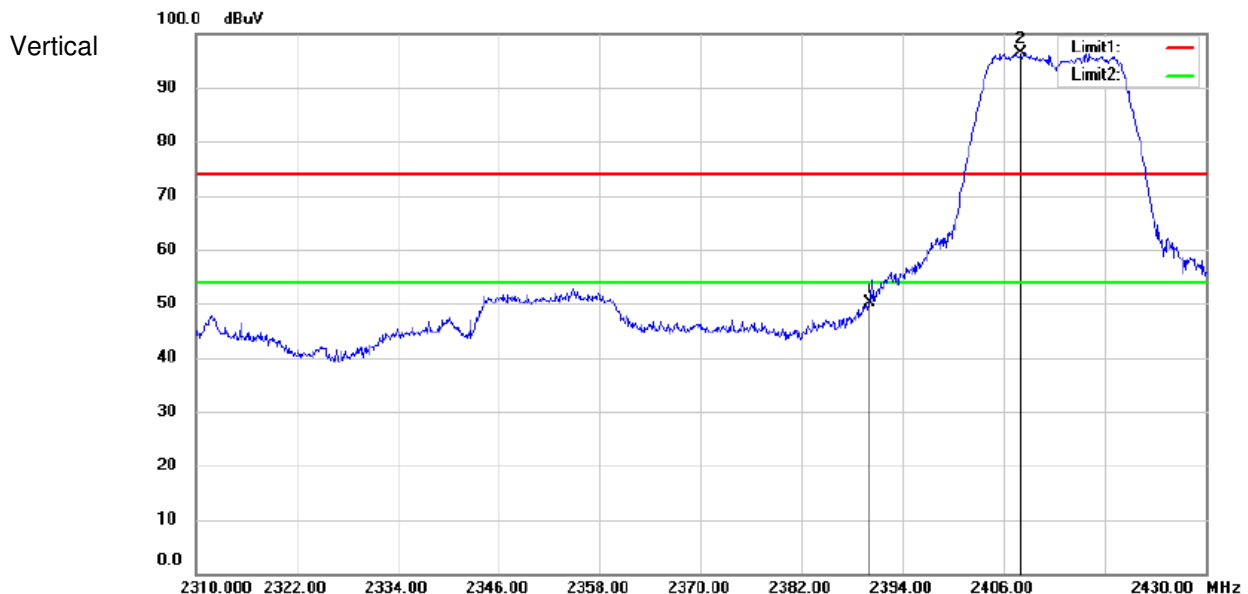
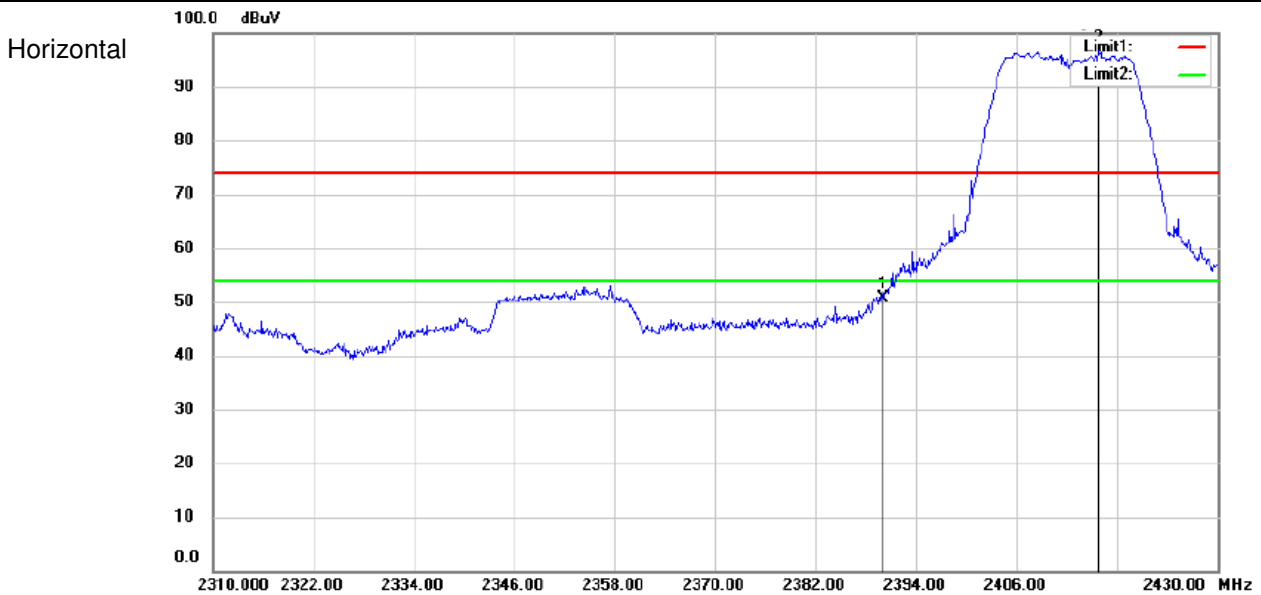

Test Mode: 802.11g

Channel: Highest

MK.	Frequency (MHz)	Reading (dBuV/m)	Corrected factor(dB)	Result (dBuV/m)	Limit (dBuV/m)	Over Limit (dB)	Detector	Polarization
1	2458.40	100.89	-4.38	96.51	74	22.51	Peak	Horizontal
2	2483.50	59.44	-4.53	54.91	74	-19.09	Peak	Horizontal
1	2464.70	73.60	-4.41	69.19	54	15.19	Average	Horizontal
2	2483.50	34.86	-4.53	30.33	54	-23.67	Average	Horizontal

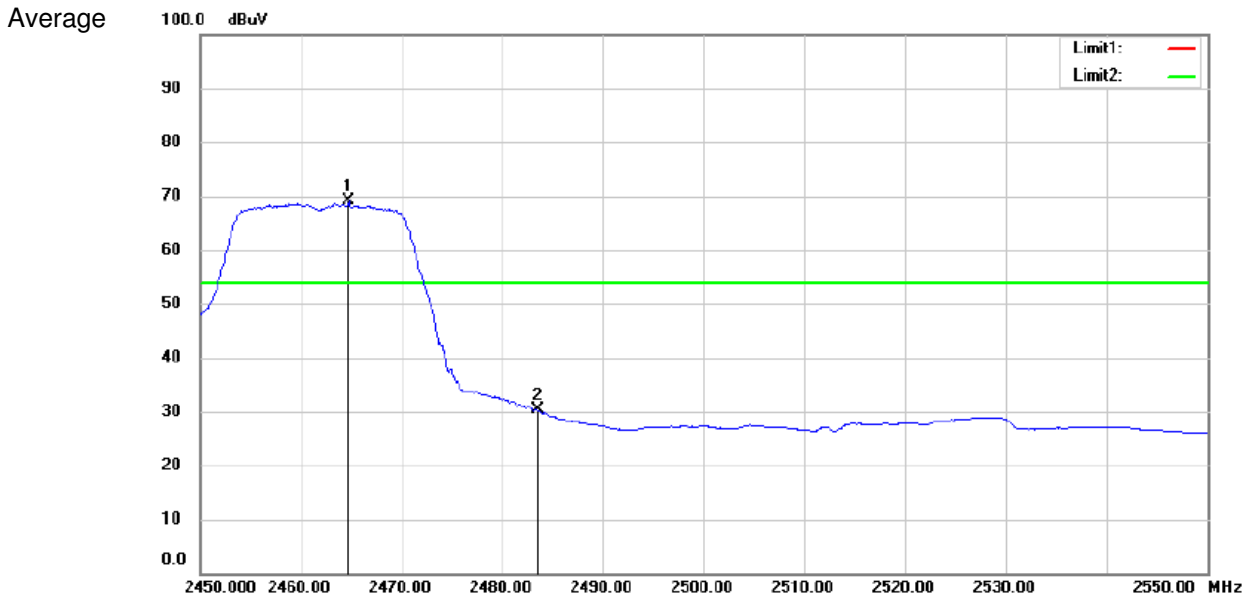
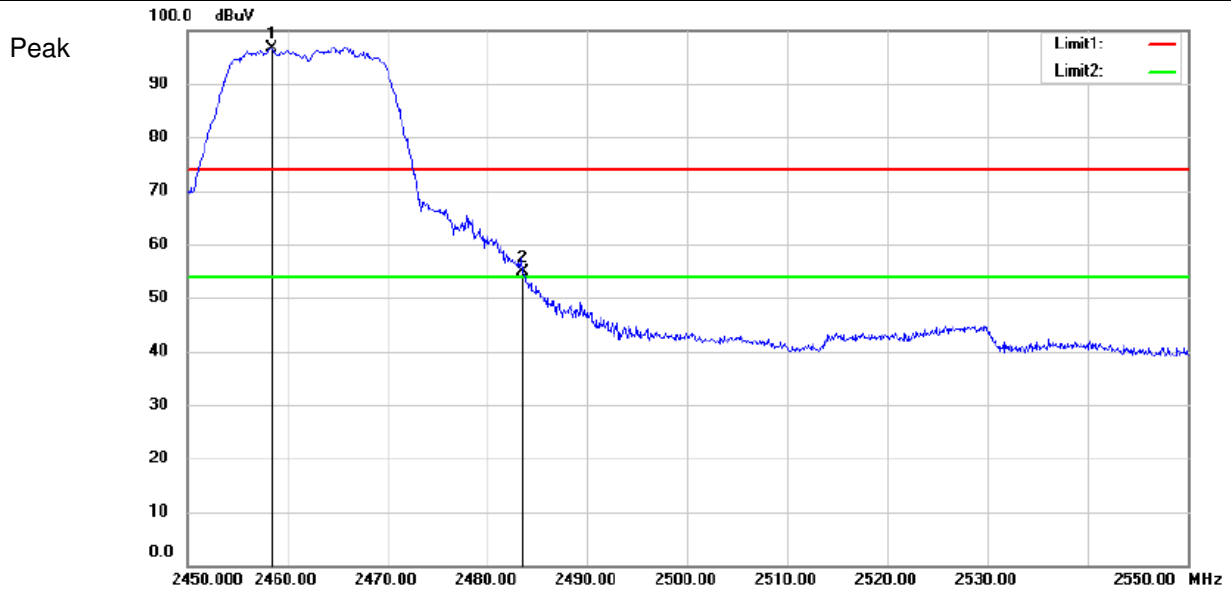

Test Mode: 802.11g

Channel: Highest

MK.	Frequency (MHz)	Reading (dBuV/m)	Corrected factor(dB)	Result (dBuV/m)	Limit (dBuV/m)	Over Limit (dB)	Detector	Polarization
1	2465.80	101.15	-4.42	96.73	74	22.73	Peak	Vertical
2	2483.50	61.45	-4.53	56.92	74	-17.08	Peak	Vertical
1	2464.40	73.05	-4.41	68.64	54	14.64	Average	Vertical
2	2483.50	35.14	-4.53	30.61	54	-23.39	Average	Vertical

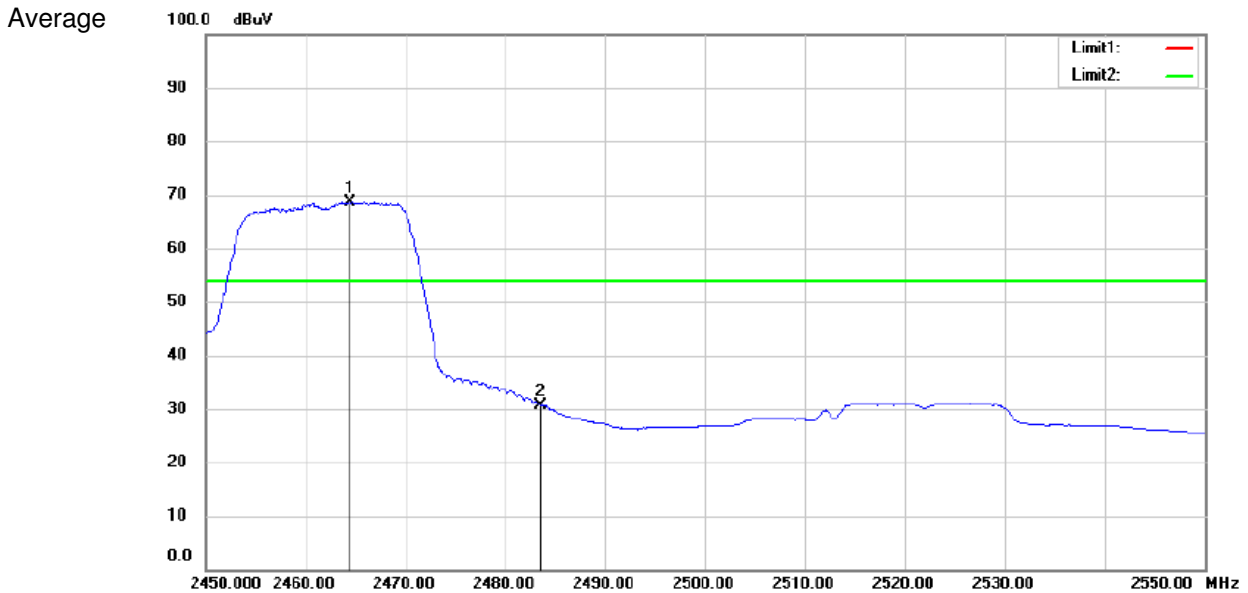
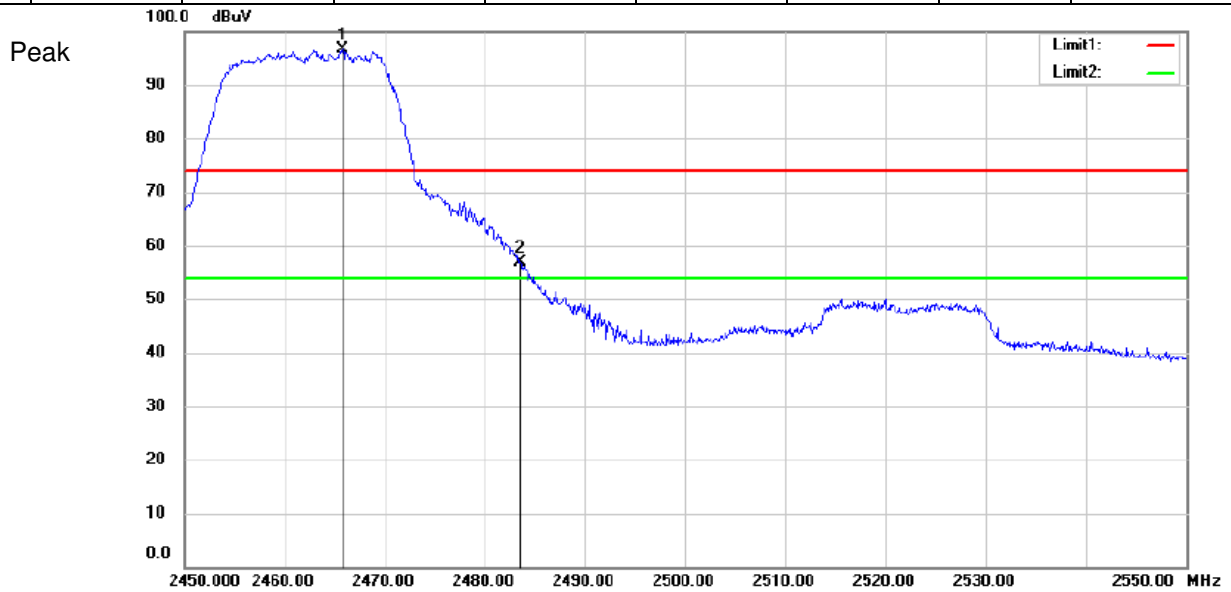



- Remark: 1. Test Level = Receiver Reading + Antenna Factor + Cable Loss- Preamplifier Factor
2. No any other emission which falls in restricted bands can be detected and be reported.
3. If the Peak value below the AV Limit, the AV test doesn't perform for this submission.

All frequencies within the "Restricted bands" have been evaluated to compliance. Section 15.205 Restricted bands of operation.

Except as shown in paragraph (d) of this section, only spurious emissions are permitted in any of the frequency bands listed below:

1. FCC Part 15, Subpart C Section 15.205 Restricted bands of operation.

MHz	MHz	MHz	GHz
0.090 - 0.110	16.42 - 16.423	399.9 - 410	4.5 - 5.15
1.495 - 0.505	16.69475 - 16.69525	608 - 614	5.35 - 5.46
2.1735 - 2.1905	16.80425 - 16.80475	960 - 1240	7.25 - 7.75
4.125 - 4.128	25.5 - 25.67	1300 - 1427	8.025 - 8.5
4.17725 - 4.17775	37.5 - 38.25	1435 - 1626.5	9.0 - 9.2
4.20725 - 4.20775	73 - 74.6	1645.5 - 1646.5	9.3 - 9.5
6.215 - 6.218	74.8 - 75.2	1660 - 1710	10.5 - 12.7
6.26775 - 6.26825	108 - 121.94	1718.8 - 1722.2	13.25 - 13.4
6.31175 - 6.31225	123 - 138	2200 - 2300	14.47 - 14.5
8.291 - 8.294	149.9 - 150.05	2310 - 2390	15.35 - 16.2
8.362 - 8.366	156.52475 - 156.52525	2483.5 - 2500	17.7 - 21.4
8.37625 - 8.38675	156.7 - 156.9	2655 - 2900	22.01 - 23.12
8.41425 - 8.41475	162.0125 - 167.17	3260 - 3267	23.6 - 24.0
12.29 - 12.293	167.72 - 173.2	3332 - 3339	31.2 - 31.8
12.51975 - 12.52025	240 - 285	3345.8 - 3358	36.43 - 36.5
12.57675 - 12.57725	322 - 335.4	3600 - 4400	
13.36 - 13.41			

2. RSS-Gen section 7.2.2 Restricted bands of operation

MHz	MHz	GHz
0.090-0.110	240-285	9.0-9.2
2.1735-2.1905	322-335.4	9.3-9.5
3.020-3.026	399.9-410	10.6-12.7
4.125-4.128	608-614	13.25-13.4
4.17725-4.17775	960-1427	14.47-14.5
4.20725-4.20775	1435-1626.5	15.35-16.2
5.677-5.683	1645.5-1646.5	17.7-21.4
6.215-6.218	1660-1710	22.01-23.12
6.26775-6.26825	1718.8-1722.2	23.6-24.0
6.31175-6.31225	2200-2300	31.2-31.8
8.291-8.294	2310-2390	36.43-36.5
8.362-8.366	2655-2900	Above 38.6
8.37625-8.38675	3260-3267	
8.41425-8.41475	3332-3339	
12.29-12.293	3345.8-3358	
12.51975-12.52025	3500-4400	
12.57675-12.57725	4500-5150	
13.36-13.41	5350-5460	
16.42-16.423	7250-7750	
16.69475-16.69525	8025-8500	
16.80425-16.80475		
25.5-25.67		
37.5-38.25		
73-74.6		
74.8-75.2		
108-138		
156.52475-156.52525		
156.7-156.9		

7.9 99% Occupied Bandwidth

Test Configuration:

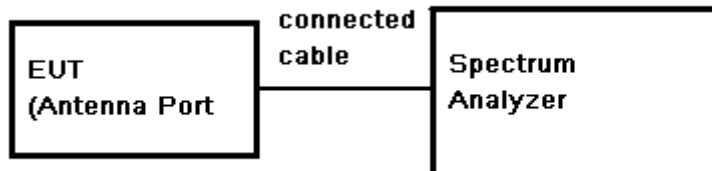

Test Procedure:

1. Remove the antenna from the EUT and then connect a low RF cable from the antenna port to the spectrum;
2. Set the spectrum analyzer: Span = approximately 2 to 3 times the 20dB bandwidth, centred on the hopping channel;
3. Set the spectrum analyzer: RBW \geq 1% of the 20dB bandwidth (set 1MHz). VBW \geq RBW. Sweep = auto; Detector Function = Peak. Trace = Max Hold.
4. Mark the peak frequency and -20dB points.

Test Result:

Pass

Test Date:

Antenna	Test Mode	Channel (MHz)	Bandwidth (MHz)
Antenna A	802.11b	Lowest (2412)	15.99
		Middle (2437)	15.99
		Highest (2462)	15.96
	802.11g	Lowest (2412)	16.47
		Middle (2437)	16.44
		Highest (2462)	16.41
Antenna B	802.11b	Lowest (2412)	15.99
		Middle (2437)	15.96
		Highest (2462)	15.96
	802.11g	Lowest (2412)	16.47
		Middle (2437)	16.44
		Highest (2462)	16.44

Test plot as follows:
Antenna A:

Test Mode: 802.11b

Channel: lowest

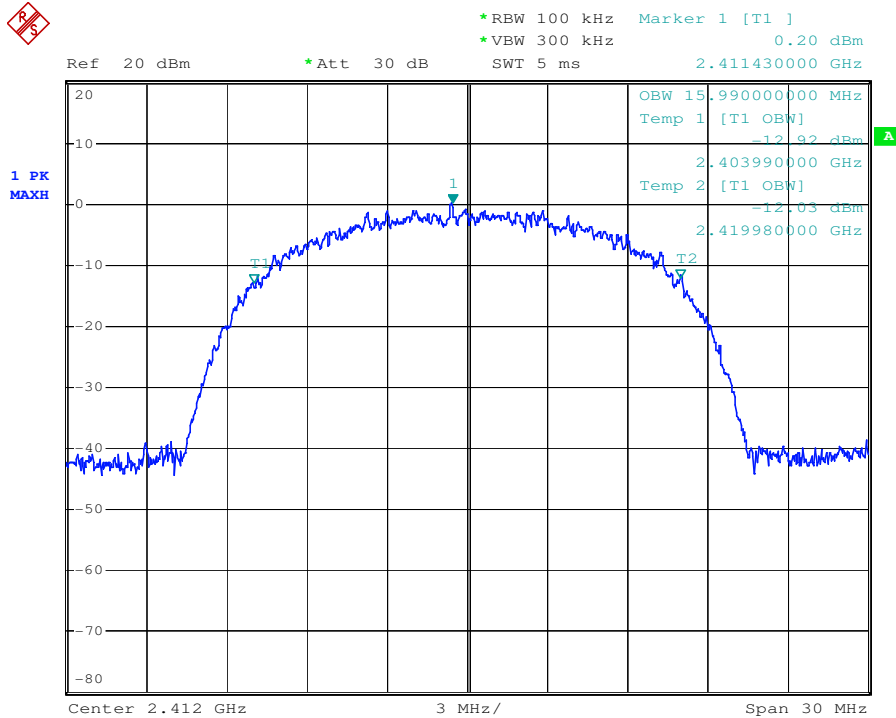

Test Mode: 802.11b

Channel: Middle

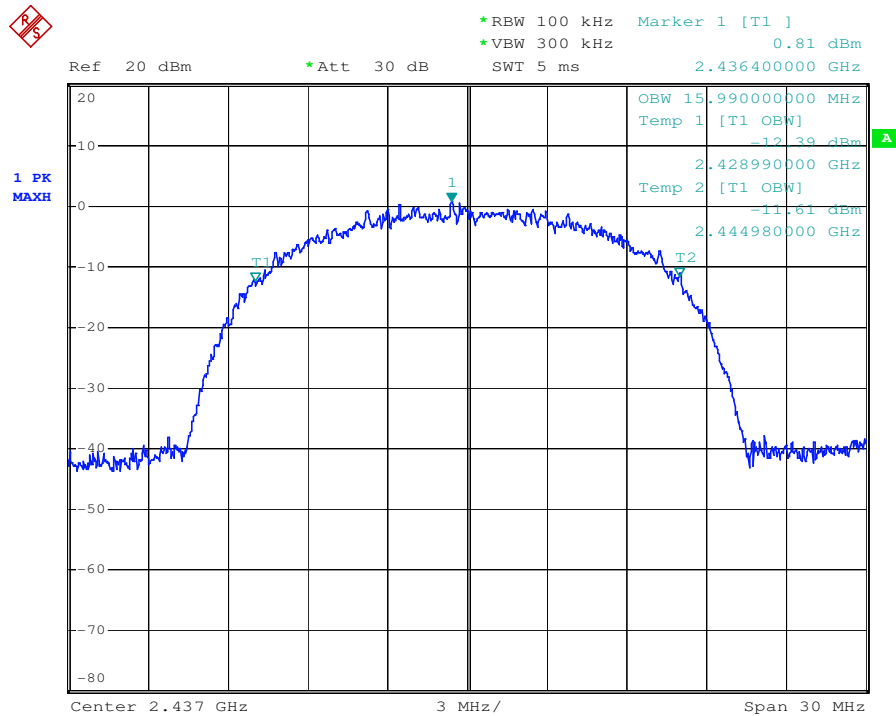

Test Mode: 802.11b

Channel: Highest

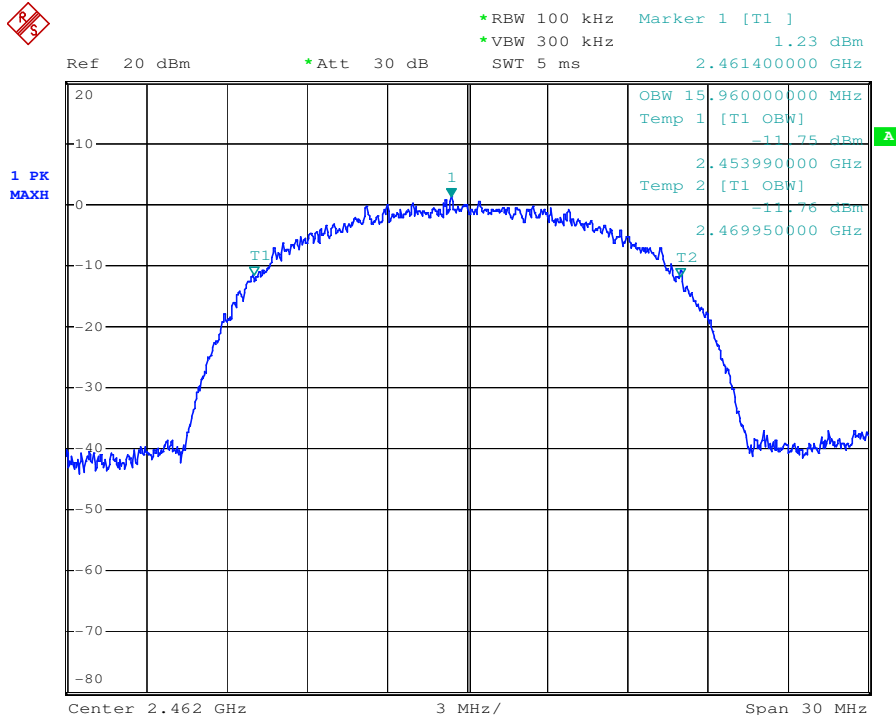

Test Mode: 802.11g

Channel: lowest

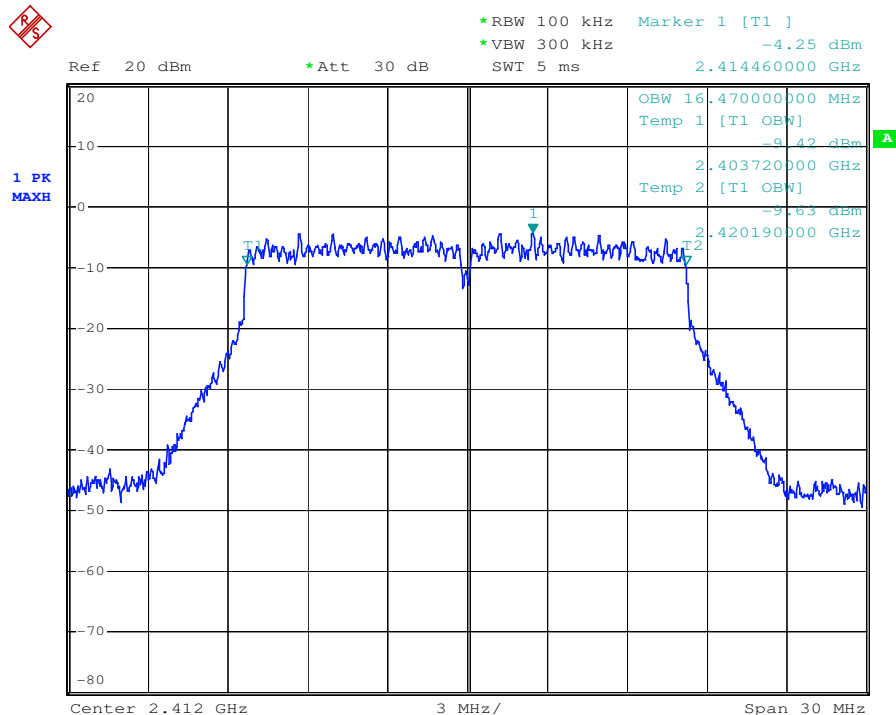

Test Mode: 802.11g

Channel: Middle

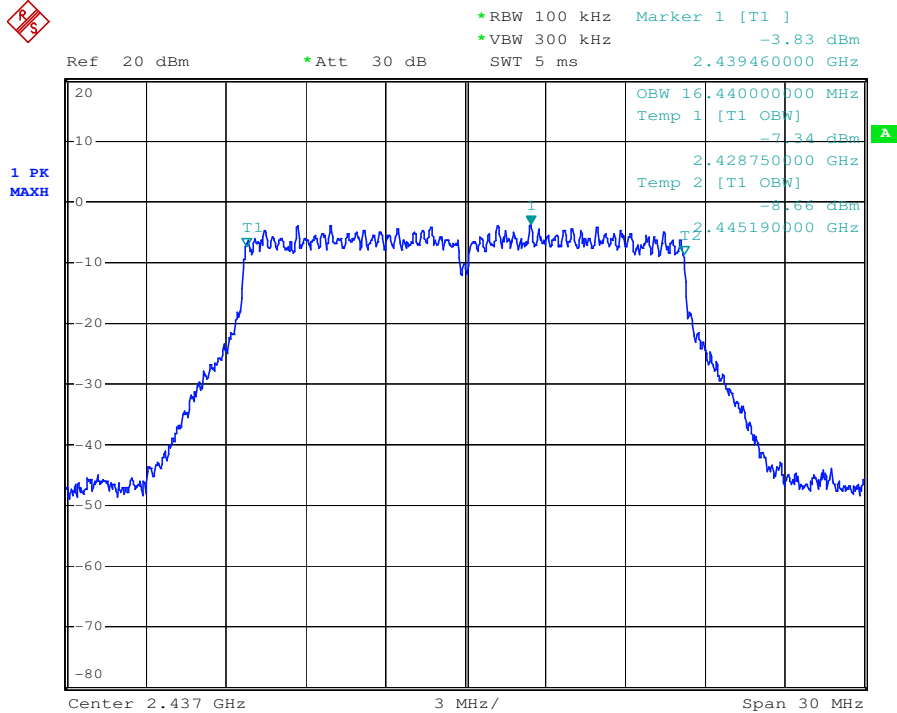

Test Mode: 802.11g

Channel: Highest

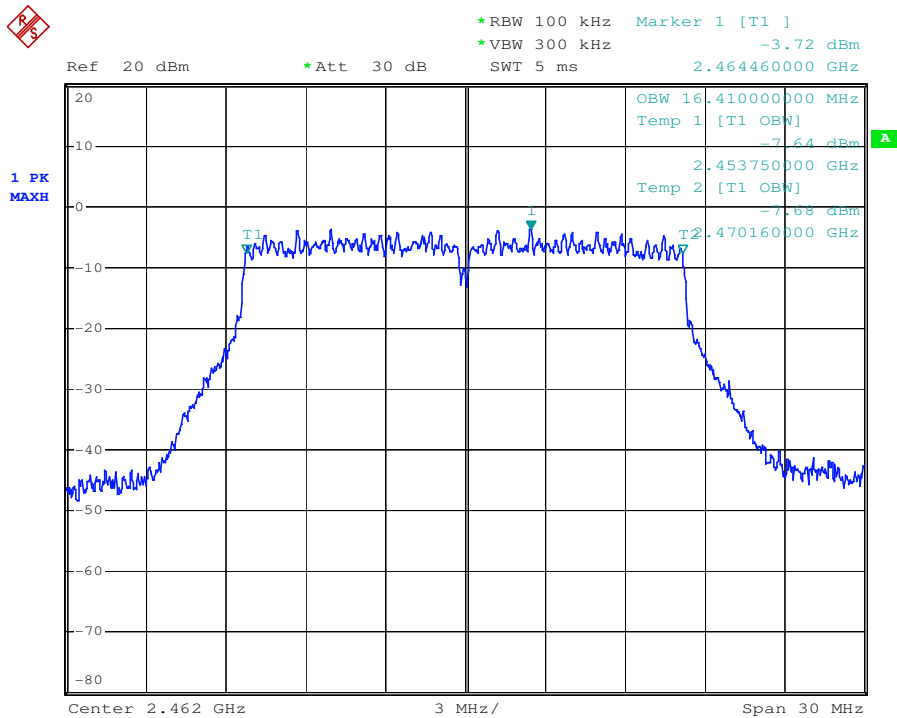

Antenna B:

Test Mode: 802.11b

Channel: lowest

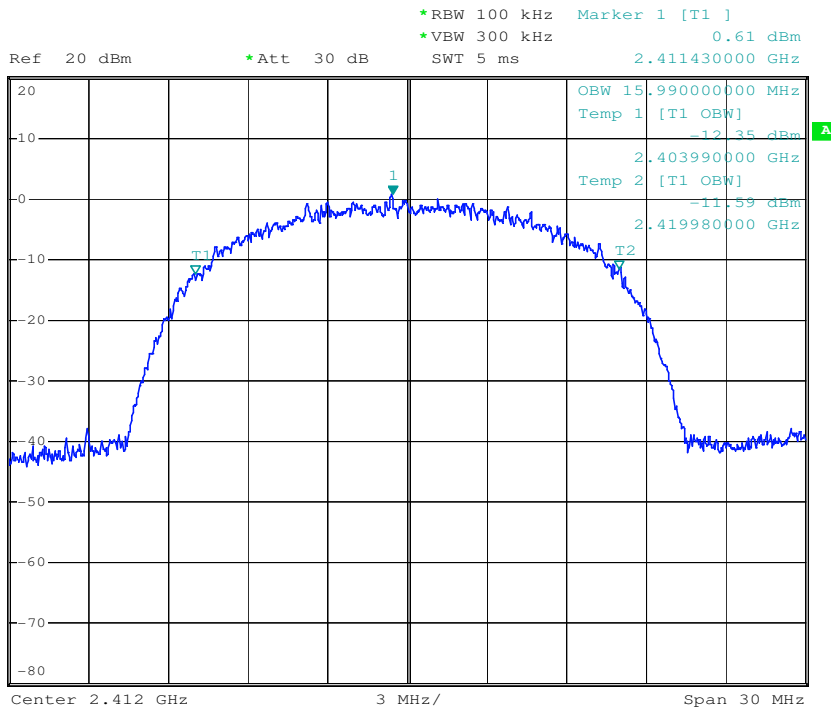

Test Mode: 802.11b

Channel: Middle

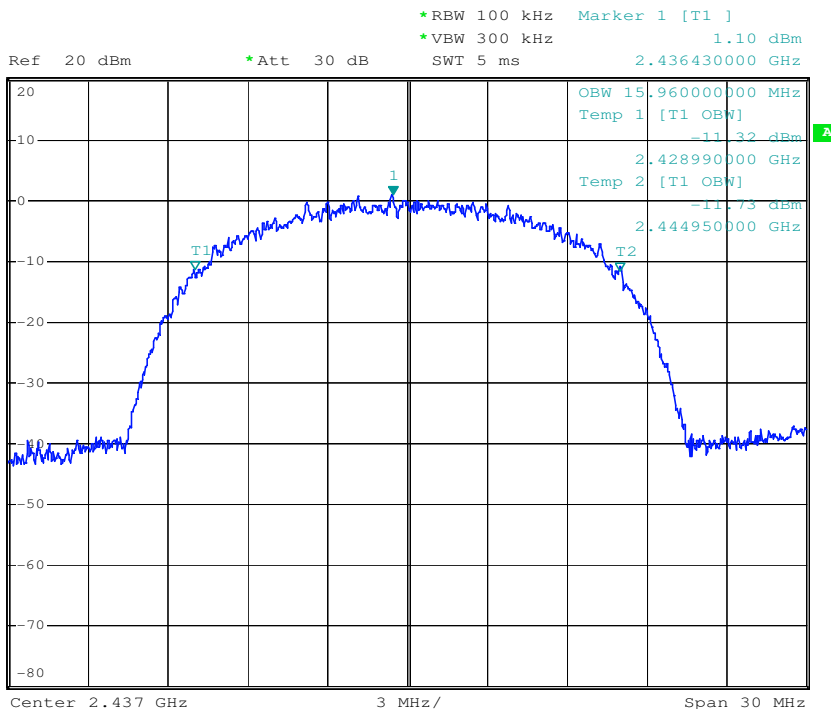

Test Mode: 802.11b

Channel: Highest

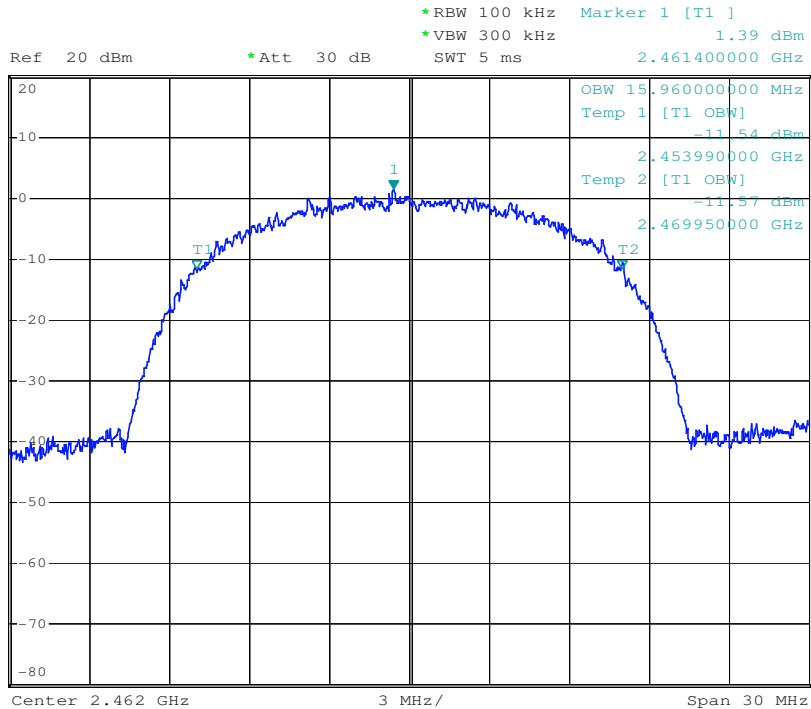

Test Mode: 802.11g

Channel: lowest

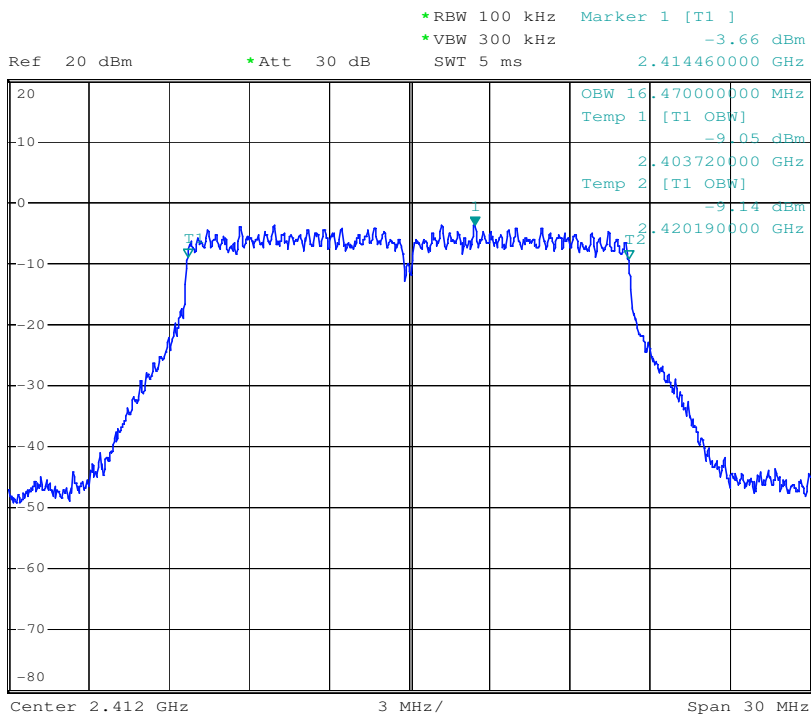

Test Mode: 802.11g

Channel: Middle

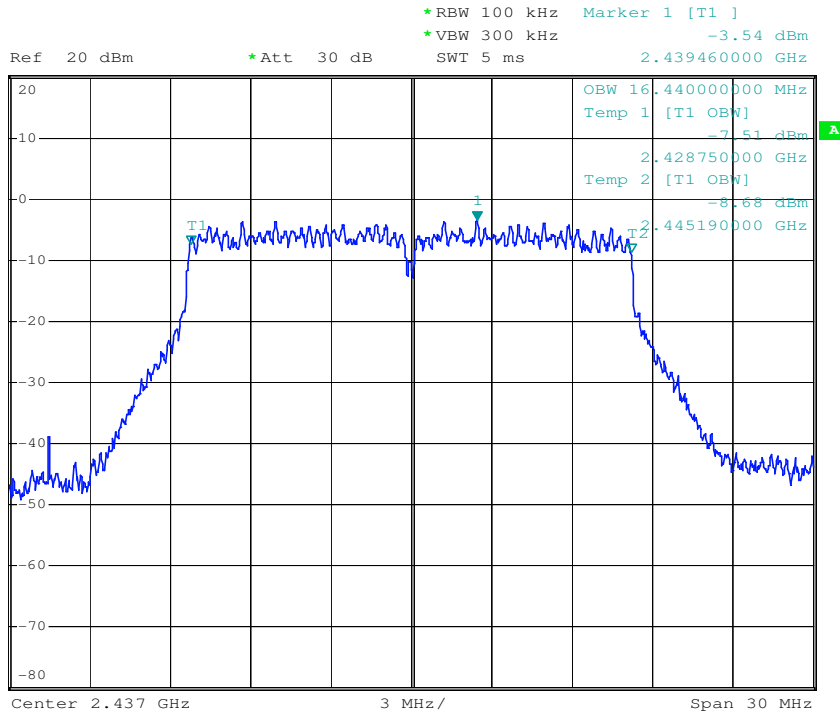

Test Mode: 802.11g

Channel: Highest

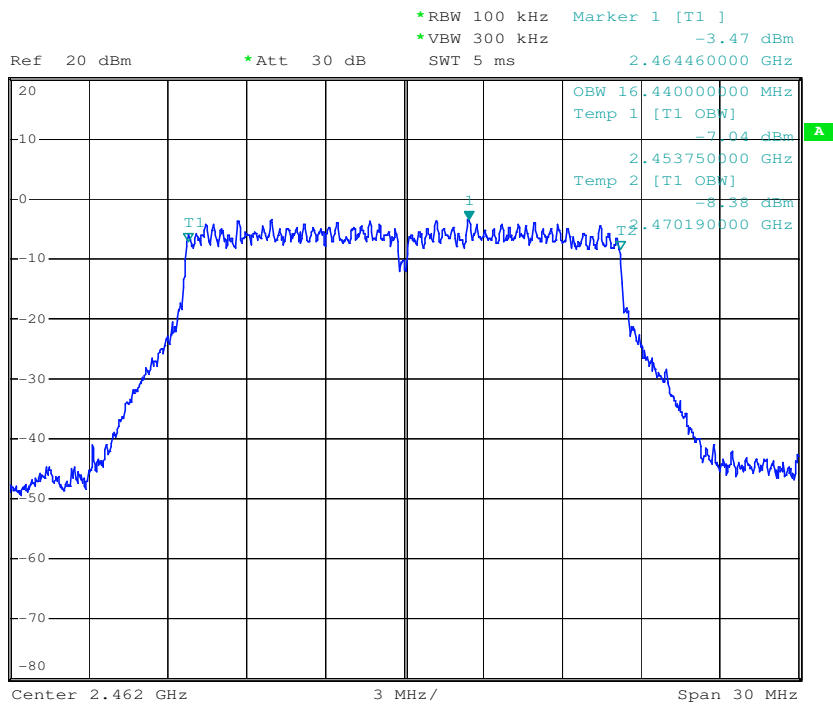

8 Test Setup Photographs

Refer to the < Air 200 V2 _Test Setup photos-FCC>.

9 EUT Constructional Details

Refer to the < Air 200 V2 _External Photos-FCC > & < Air 200 V2 _Internal Photos-FCC>.

--End of the Report--