



**SGS-CSTC Standards Technical Services  
(Shanghai) Co., Ltd.**

588 West Jindu Road, Songjiang District, Shanghai, China  
Telephone: +86 (0) 21 6191 5666  
Fax: +86 (0) 21 6191 5678  
ee.shanghai@sgs.com

Report No.: SHEM140600146603  
Page: 1 of 95

**1 Cover Page**

# ***RF TEST REPORT***

<b>Application No.:</b>	SHEM1406001466RF
<b>Applicant:</b>	Audio Partnership PLC
<b>FCC ID:</b>	YKBMA101-013
<b>IC:</b>	9095A-MA101013
<b>Equipment Under Test (EUT):</b> <b>NOTE:</b> The following sample(s) submitted was/were identified on behalf of the client as	
<b>Product Name:</b>	Wireless Music System
<b>Model No.(EUT):</b>	Air 100 V2
<b>Standards:</b>	FCC PART 15 Subpart C: 2013 RSS-210 Issue 8 (December 2010) RSS-Gen Issue 3 (December 2010)
<b>Date of Receipt:</b>	June 14, 2014
<b>Date of Test:</b>	June 19, 2014 to June 25, 2014
<b>Date of Issue:</b>	July 11, 2014
<b>Test Result:</b>	<b>Pass*</b>

\* In the configuration tested, the EUT (Equipment under test) complied with the standards specified above.



**Tony Wu**  
**E&E Section Manager**

**SGS-CSTC (Shanghai) Co., Ltd.**



The manufacturer should ensure that all products in series production are in conformity with the product sample detailed in this report. If the product in this report is used in any configuration other than that detailed in the report, the manufacturer must ensure the new system complies with all relevant standards.

The report must not be used by the client to claim product certification, approval, or endorsement by NVLAP, NIST, or any agency of the federal government. All test results in this report can be traceable to National or International Standards.

This document is issued by the Company subject to its General Conditions of Service printed overleaf, available on request or accessible at [www.sgs.com/terms\\_and\\_conditions.htm](http://www.sgs.com/terms_and_conditions.htm) and, for electronic format documents, subject to Terms and Conditions for Electronic Documents at [www.sgs.com/terms\\_e-document.htm](http://www.sgs.com/terms_e-document.htm). Attention is drawn to the limitation of liability, indemnification and jurisdiction issues defined therein. Any holder of this document is advised that information contained hereon reflects the Company's findings at the time of its intervention only and within the limits of Client's instructions, if any. The Company's sole responsibility is to its Client and this document does not exonerate parties to a transaction from exercising all their rights and obligations under the transaction documents. This document cannot be reproduced except in full, without prior written approval of the Company. Any unauthorized alteration, forgery or falsification of the content or appearance of this document is unlawful and offenders may be prosecuted to the fullest extent of the law. Unless otherwise stated the results shown in this test report refer only to the sample(s) tested and such sample(s) are retained for 90 days only

## 2 Version

Revision Record				
Version	Chapter	Date	Modifier	Remark
00		July 11, 2014		Original

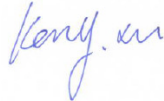
<b>Authorized for issue by:</b>			
<b>Engineer</b>		Eddy Zong _____ <b>Print Name</b>	 _____ <b>Print Name</b>
<b>Clerk</b>		Susie Liu _____ <b>Print Name</b>	 _____ <b>Print Name</b>
<b>Reviewer</b>		Keny Xu _____ <b>Print Name</b>	 _____ <b>Print Name</b>

### 3 Test Summary

Test Item	FCC Test Requirement	IC Test Requirement	Test method	Result
Antenna Requirement	FCC Part 15, Subpart C Section 15.203/15.247 (c)	RSS-Gen 7.1.2	---	PASS
AC Power Line Conducted Emission	FCC Part 15, Subpart C Section 15.207	RSS-Gen Section 7.2.4	ANSI C63.10 (2009) Section 6.2	PASS
20dB Occupied Bandwidth	FCC Part 15, Subpart C Section 15.247 (a)(1)	RSS 210 A 8.1(a)	ANSI C63.10 (2009) Section 6.9.1	PASS
Conducted Peak Output Power	FCC Part 15, Subpart C Section 15.247 (b)(1)	RSS 210 A 8.4(2)	ANSI C63.10 (2009) Section 6.10.1	PASS
Carrier Frequencies Separation	FCC Part 15, Subpart C Section 15.247 (a)(1)	RSS 210 A 8.1(b)	ANSI C63.10 (2009) Section 7.7.2	PASS
Hopping Channel Number	FCC Part 15, Subpart C Section 15.247 (b)	RSS 210 A 8.1(d)	ANSI C63.10 (2009) Section 7.7.3	PASS
Dwell Time	FCC Part 15, Subpart C Section 15.247 (a)(1)	RSS 210 A 8.1(d)	ANSI C63.10 (2009) Section 7.7.4	PASS
RF Conducted Spurious Emissions and Band-edge	FCC Part 15, Subpart C Section 15.247(d)	RSS 210 A 8.5	ANSI C63.10 (2009) Section 7.7.9&7.7.10	PASS
Radiated Spurious Emissions and Band- edge	FCC Part 15, Subpart C Section 15.209&15.205	RSS-Gen section 4.9	ANSI C63.10 (2009) Section 6.5&6.6&6.7	PASS
99% Occupied Bandwidth	---	RSS-Gen section 4.6.1	RSS-Gen section 4.6.1	PASS

## 4 Contents

	Page
<b>1 COVER PAGE .....</b>	<b>1</b>
<b>2 VERSION .....</b>	<b>2</b>
<b>3 TEST SUMMARY .....</b>	<b>3</b>
<b>4 CONTENTS.....</b>	<b>4</b>
<b>5 GENERAL INFORMATION .....</b>	<b>5</b>
5.1 CLIENT INFORMATION.....	5
5.2 GENERAL DESCRIPTION OF E.U.T.....	5
5.3 TECHNICAL SPECIFICATIONS.....	5
5.4 TEST MODE.....	5
5.5 DESCRIPTION OF SUPPORT UNITS.....	6
5.6 TEST CHANNEL .....	6
5.7 TEST LOCATION .....	6
5.8 TEST FACILITY .....	7
5.9 MEASUREMENT UNCERTAINTY .....	7
<b>6 EQUIPMENTS USED DURING TEST.....</b>	<b>8</b>
<b>7 TEST RESULTS .....</b>	<b>9</b>
7.1 E.U.T. TEST CONDITIONS .....	9
7.2 FREQUENCY HOPPING SYSTEM REQUIREMENT .....	10
7.3 ANTENNA REQUIREMENT.....	12
7.4 CONDUCTED EMISSIONS ON MAINS TERMINALS .....	13
7.5 20dB OCCUPIED BANDWIDTH.....	17
7.6 CONDUCTED PEAK OUTPUT POWER .....	23
7.7 CARRIER FREQUENCIES SEPARATED .....	30
7.8 HOPPING CHANNEL NUMBER.....	33
7.9 DWELL TIME .....	37
7.10 CONDUCTED SPURIOUS EMISSIONS AND BAND-EDGE .....	47
7.10.1 Conducted spurious emission.....	48
7.10.2 Conducted Band-edge .....	62
7.11 RADIATED SPURIOUS EMISSIONS AND BAND-EDGE.....	68
7.11.1 Radiated Spurious Emissions:.....	71
7.11.2 Radiated Band edge .....	75
7.12 OCCUPIED BANDWIDTH TEST.....	89
<b>8 TEST SETUP PHOTOGRAPHS.....</b>	<b>95</b>
<b>9 EUT CONSTRUCTIONAL DETAILS.....</b>	<b>95</b>

## 5 General Information

### 5.1 Client Information

Applicant: Audio Partnership PLC  
 Address of Applicant: Gallery Court, Hankey Place, London, SE1 4BB, UNITED KINGDOM  
 Manufacturer: Audio Partnership PLC  
 Address of Manufacturer: Gallery Court, Hankey Place, London, SE1 4BB, UNITED KINGDOM  
 Factory: Hansong (Nanjing) Technology Ltd.  
 Address of Factory: 8th Kangping Road, Jiangning Economy & Technology Development Zone, Nanjing, 211106, China.

### 5.2 General Description of E.U.T.

Product Description: Mobile product  
 Brand Name: Cambridge Audio

### 5.3 Technical Specifications

Operation Frequency: 2402MHz~2480MHz  
 Bluetooth Version: 3.0+HS  
 Modulation Technique: FHSS(GFSK,  $\pi/4$ DQPSK, 8DPSK)  
 Number of Channel: 79  
 Antenna Type: Integral  
 Antenna Gain: 2 dBi  
 Power Supply: AC 100-230V 50/60Hz 150W

### 5.4 Test Mode

Test Mode	Description of Test Mode
Hopping disabled mode	Using test software to control EUT working in continuous transmitting, and select channel and modulation type.
Hopping enabled mode	Using test software to control EUT working in continuous transmitting, and hopping on status.

## 5.5 Description of Support Units

The EUT has been tested independently, or The EUT has been tested with associated equipment below.

Description	Manufacturer	Model No.	Supplied by
Laptop	Lenovo	ThinkPad X100e	SGS
BT test board	/	/	SGS

Software name	Manufacturer	Version	Supplied By
Blue Test3 (For CSR)	/	2.5.0	SGS

Description of connection

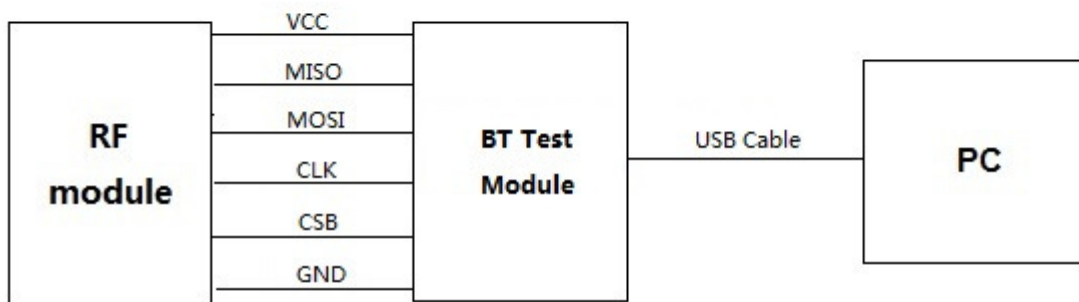

## 5.6 Test Channel

Using test software was control EUT work in continuous transmitter mode. And select test channel as below:

Channel	Frequency (MHz)
Low Channel	2402
Middle Channel	2441
High Channel	2480

## 5.7 Test Location

All tests were performed at:

SGS-CSTC Standards Technical Services (Shanghai) Co., Ltd.

No.588 West Jindu Road, Songjiang District, Shanghai, China.201612.

Tel: +86 21 6191 5666

Fax: +86 21 6191 5678

## 5.8 Test Facility

The test facility is recognized, certified, or accredited by the following organizations:

- **CNAS (No. CNAS L0599)**

CNAS has accredited SGS-CSTC Standards Technical Services (Shanghai) Co., Ltd. to ISO/IEC 17025:2005 General Requirements for the Competence of Testing and Calibration Laboratories (CNAS-CL01 Accreditation Criteria for the Competence of Testing and Calibration Laboratories) for the competence in the field of testing. Date of expiry: 2014-07-26.

- **FCC – Registration No.: 402683**

SGS-CSTC Standards Technical Services (Shanghai) Co., Ltd. has been registered and fully described in a report filed with the Federal Communications Commission (FCC). The acceptance letter from the FCC is maintained in our files. Registration No.: 402683, Expiry Date: 2015-02-22.

- **Industry Canada (IC) – IC Assigned Code: 8617A**

The 3m Semi-anechoic chamber of SGS-CSTC Standards Technical Services (Shanghai) Co., Ltd. has been registered by Certification and Engineering Bureau of Industry Canada for radio equipment testing with Registration No.: 8617A-1. Expiry Date: 2017-06-18.

- **VCCI (Member No.: 3061)**

The 3m Semi-anechoic chamber and Shielded Room of SGS-CSTC Standards Technical Services (Shanghai) Co., Ltd. has been registered in accordance with the Regulations for Voluntary Control Measures with Registration No.: R-3868 and C-4336 respectively. Date of Registration: 2012-05-29. Date of Expiry: 2015-05-28.

## 5.9 Measurement Uncertainty

No.	Parameter	Measurement Uncertainty
1	Radio Frequency	$< \pm 1 \times 10^{-5}$
2	Total RF power, conducted	$< \pm 1.5$ dB
3	RF power density, conducted	$< \pm 3$ dB
4	Spurious emissions, conducted	$< \pm 3$ dB
5	All emissions, radiated	$< \pm 6$ dB (30MHz – 1GHz) $< \pm 6$ dB (above 1GHz)
6	Temperature	$< \pm 1^{\circ}\text{C}$
7	Humidity	$< \pm 5$ %
8	DC and low frequency voltages	$< \pm 3$ %

## 6 Equipments Used during Test

Item	Test Equipment	Manufacturer	Model No.	Serial No.	Cal. Date	Cal. Due date
1	EMI test receiver	Rohde & Schwarz	ESCS30	100086	2014-02-14	2015-02-13
2	Line impedance stabilization network	SCHWARZBECK	NSLK8127	8127-490	2014-02-14	2015-02-13
3	Line impedance stabilization network	ETS	3816/2	00034161	2014-02-14	2015-02-13
4	Spectrum Analyzer	Rohde & Schwarz	FSP-30	2705121009	2014-02-14	2015-02-13
5	EMI test receiver	Rohde & Schwarz	ESU40	100109	2014-02-14	2015-02-13
6	Active Loop Antenna (9kHz to 30MHz)	Rohde & Schwarz	FMZB 1519	1519-034	2014-03-19	2015-03-18
7	Broadband UHF-VHF ANTENNA (25MHz to 2GHz)	SCHWARZBECK	VULB9168	9168-313	2014-02-14	2015-02-13
8	Ultra broadband antenna (25MHz to 3GHz)	Rohde & Schwarz	HL562	100227	2013-10-09	2014-10-08
9	Horn Antenna (1GHz to 18GHz)	Rohde & Schwarz	HF906	100284	2014-02-14	2015-02-13
10	Horn Antenna (1GHz to 18GHz)	SCHWARZBECK	BBHA9120D	9120D-679	2013-07-28	2014-07-27
11	Horn Antenna (14GHz to 40GHz)	SCHWARZBECK	BBHA 9170	BBHA9170373	2014-02-14	2015-02-13
12	Pre-amplifier (9KHz – 2GHz)	LNA6900	TESEQ	71033	2014-02-14	2015-02-13
13	Pre-amplifier (1GHz – 26.5GHz)	Rohde & Schwarz	SCU-F0118-G40-BZ4-CSS(F)	10001	2014-02-14	2015-02-13
14	Pre-amplifier (14GHz – 40GHz)	Rohde & Schwarz	SCU-F1840-G35-BZ3-CSS(F)	10001	2014-02-14	2015-02-13
15	Tunable Notch Filter	Wainwright instruments GmbH	WRCT800.0/8 80.0-0.2/40-5SSK	9	2014-06-02	2015-06-01
16	High pass Filter	FSCW	HP 12/2800-5AA2	19A45-02	2014-06-02	2015-06-01
17	High-low temperature cabinet	Suzhou Zhihe	TL-40	50110050	2014-04-13	2015-04-12
18	AC power stabilizer	WOCEN	6100	51122	2014-06-02	2015-06-01
19	DC power	QJE	QJ30003SII	611145	2014-06-02	2015-06-01
20	Signal Generator (Interferer)	Agilent	SMR40	100555	2014-02-14	2015-02-13
21	Signal Generator (Blocker)	Rohde & Schwarz	SMJ100A	02.20.360.142	2014-02-14	2015-02-13
22	Splitter	Anritsu	MA1612A	M12265	/	/
23	Coupler	e-meca	803-S-1	900-M01	/	/



## 7 Test Results

### 7.1 E.U.T. test conditions

**Test Power:** AC 120V, 60Hz

**Requirements:** 15.31(e) For intentional radiators, measurements of the variation of the input power or the radiated signal level of the fundamental frequency component of the emission, as appropriate, shall be performed with the supply voltage varied between 85% and 115% of the nominal rated supply voltage. For battery operated equipment, the equipment tests shall be performed using a new battery.

<b>Operating Environment:</b>	Temperature:	20.0 -25.0 °C
	Humidity:	35-75 % RH
	Atmospheric Pressure:	99.2 -102 kPa

**Test frequencies:** According to the 15.31(m) Measurements on intentional radiators or receivers, other than TV broadcast receivers, shall be performed and, if required, reported for each band in which the device can be operated with the device operating at the number of frequencies in each band specified in the following table:

Frequency range over which device operates	Number of frequencies	Location in the range of operation
1 MHz or less	1	Middle
1 to 10 MHz	2	1 near top and 1 near bottom
More than 10 MHz	3	1 near top, 1 near middle and 1 near bottom

Pursuant to Part 15.31(c) For swept frequency equipment, measurements shall be made with the frequency sweep stopped at those frequencies chosen for the measurements to be reported.

Test frequency is the lowest channel: 0 channel (2402MHz), middle channel: 39 channel (2441MHz) and highest channel: 78 channel (2480MHz) with fixed at channel.

## 7.2 Frequency Hopping System Requirement

This transmitter device is frequency hopping device, and complies with Part 15.247 (g) and (h)

This device uses Bluetooth radio which operates in 2400~2483.5MHz band. Bluetooth uses a radio technology called frequency-hopping spread spectrum, which chops up the data being sent and transmits chunks of it on up to 79 bands(1MHz each; centred from 2402~2480MHz) in the range 2400~2483.5MHz. The transmitter switches hop frequencies 1600 times per second to assure a high degree of data security. All Bluetooth devices participating in a given piconet are synchronized to the frequency-hopping channel for the piconet. The frequency hopping sequence is determined by the master's device address and the phase of the hopping sequence (the frequency to hop at a specific time) is determined by the master's internal clock. Therefore, all slaves in a piconet must know the master's device address and must synchronize their clocks with the master's clock.

Adaptive Frequency Hopping (AFH) was introduced in the Bluetooth specification to provide an effective way for a Bluetooth radio to counteract normal interference. AFH identifies "bad" channels, where either other wireless devices are interfering with the Bluetooth signal or the Bluetooth signal is interfering with another device. The AFH-enabled Bluetooth device will then communicate with other devices within its piconet to share detail of any identified band channels. The devices will then switch to alternative available "good" channels, away from the areas of interference, thus having no impact on the bandwidth used.

The device use CSR8645 chips and the chips has get BQB certification, so the number of minimum hopping channel is greater than 15

### EUT Pseudorandom Frequency Hopping Sequence

The same pseudorandom sequence of bits shall be used for each transmission (i.e. the packet is repeated). A PRBS-9 Sequence is used. The properties of this sequence are as follows. The Pseudorandom sequence may be generated in a nine-shift register whose 5<sup>th</sup> and 9<sup>th</sup> stage outputs are added in a modulo-two addition stage. And the result is fed back to the input of the first stage. The sequence begins with the first ONE of 9 consecutive ONES; i.e. the shift register is initialized with nine ones.

Number of shift register stages: 9

Length of pseudo-random sequence:  $2^9 - 1 = 511$  bits

Longest sequence of zeros: 8(non-inverted signal)

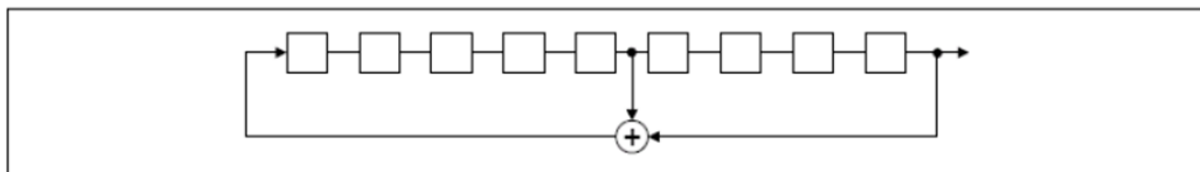

Linear Feedback Shift Register for Generation of the PRBS sequence

An example of Pseudorandom Frequency Hopping Sequence

Each frequency used equally on the average by each transmitter.

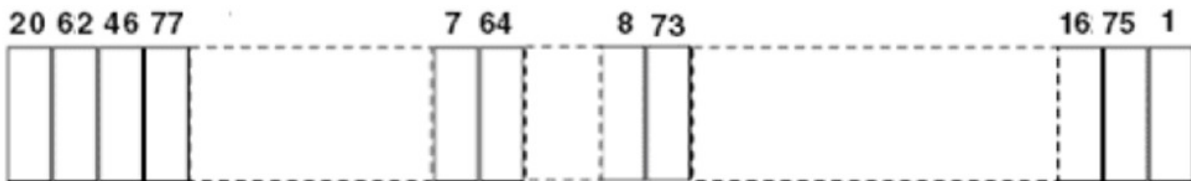

According to the Bluetooth core specification that BlueCore® CSR8645™ BGA Issue 2, The system receiver has typical input bandwidth are 100kHz and shift frequencies in synchronization with the transmitted signals.

This device was tested with an Bluetooth system receiver to check that the device maintained hopping synchronization, and the device complied with these requirements

### 7.3 Antenna Requirement

**Standard requirement:**

15.203 requirement:

An intentional radiator shall be designed to ensure that no antenna other than that furnished by the responsible party shall be used with the device. The use of a permanently attached antenna or of an antenna that uses a unique coupling to the intentional radiator, the manufacturer may design the unit so that a broken antenna can be replaced by the user, but the use of a standard antenna jack or electrical connector is prohibited

15.247(b) (4) requirement:

The conducted output power limit specified in paragraph (b) of this section is based on the use of antennas with directional gains that do not exceed 6 dBi. Except as shown in paragraph (c) of this section, if transmitting antennas of directional gain greater than 6 dBi are used, the conducted output power from the intentional radiator shall be reduced below the stated values in paragraphs (b)(1), (b)(2), and (b)(3) of this section, as appropriate, by the amount in dB that the directional gain of the antenna exceeds 6 dBi.

**EUT Antenna:**

The BT antenna is Plug-in antenna. The gain of the antenna is less than 2.0 dBi.

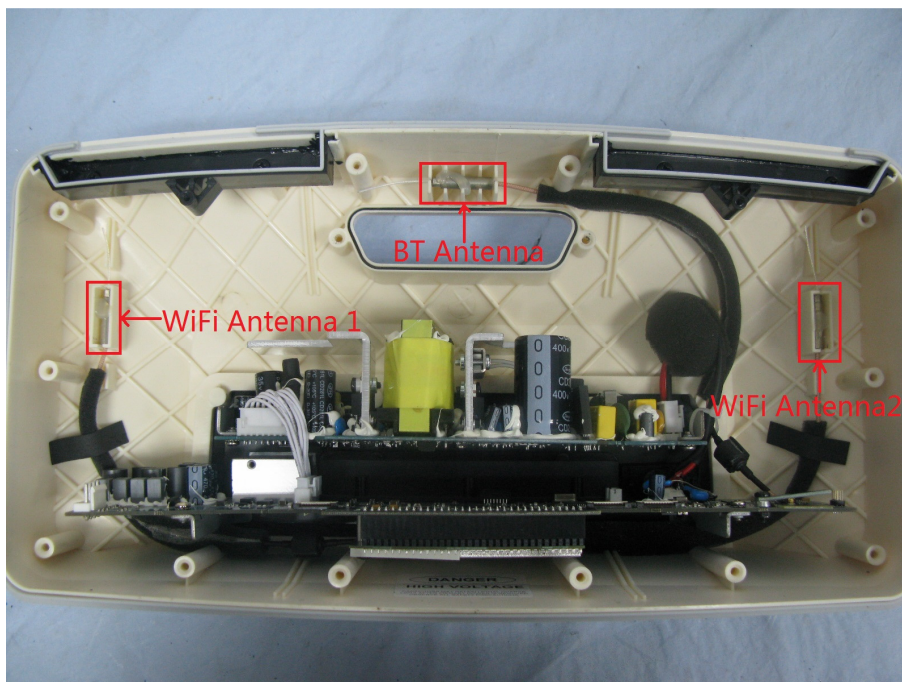

### 7.4 Conducted Emissions on Mains Terminals

**Frequency Range:** 150 KHz to 30 MHz

**Class/Severity:** Class B

**Limit:**

Frequency range MHz	Class B Limits: dB (µV)	
	Quasi-peak	Average
0.15 to 0.50	66 to 56	56 to 46
0.50 to 5	56	46
5 to 30	60	50

Note1: The limit decreases linearly with the logarithm of the frequency in the range 0.15 MHz to 0.50MHz.  
Note2: The lower limit is applicable at the transition frequency.

**Test site/setup:** Test instrumentation set-up:

Frequency Range	Detector	RBW	VBW
9KHz to 150Hz	Quasi-peak	200Hz	500Hz
150KHz to 30MHz	Quasi-peak	9kHz	30kHz

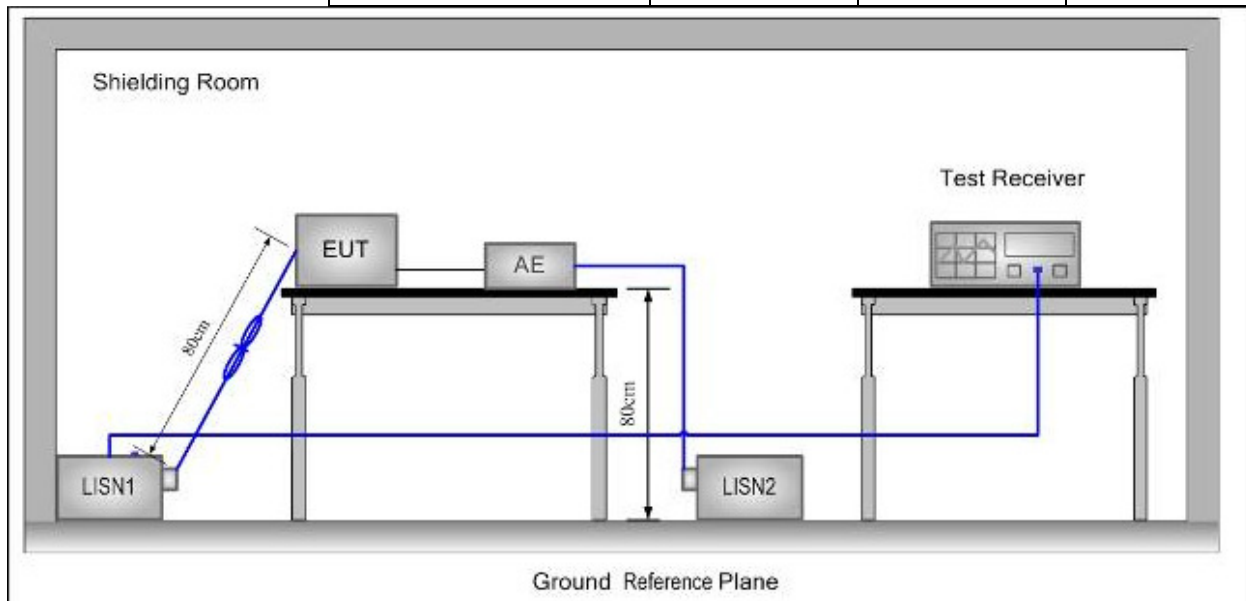

**Test Procedure:**

1. The mains terminal disturbance voltage was measured with the EUT in a shielded room.
2. The EUT was connected to AC power source through a LISN 1 (Line Impedance Stabilization Network) which provides 50Ω/50µH + 5Ω linear impedance. The power cables of all other units of the EUT were connected to a second LISN, which was bonded to the ground reference plane in the same way as the LISN for the unit being measured. A multiple socket outlet strip was used to connect multiple power cables to a single LISN provided the rating of the LISN was not exceeded

This document is issued by the Company subject to its General Conditions of Service printed overleaf, available on request or accessible at [www.sgs.com/terms\\_and\\_conditions.htm](http://www.sgs.com/terms_and_conditions.htm) and, for electronic format documents, subject to Terms and Conditions for Electronic Documents at [www.sgs.com/terms\\_e-document.htm](http://www.sgs.com/terms_e-document.htm). Attention is drawn to the limitation of liability, indemnification and jurisdiction issues defined therein. Any holder of this document is advised that information contained hereon reflects the Company's findings at the time of its intervention only and within the limits of Client's instructions, if any. The Company's sole responsibility is to its Client and this document does not exonerate parties to a transaction from exercising all their rights and obligations under the transaction documents. This document cannot be reproduced except in full, without prior written approval of the Company. Any unauthorized alteration, forgery or falsification of the content or appearance of this document is unlawful and offenders may be prosecuted to the fullest extent of the law. Unless otherwise stated the results shown in this test report refer only to the sample(s) tested and such sample(s) are retained for 90 days only

3. The tabletop EUT was placed upon a non-metallic table 0.8m above the ground reference plane. And for floor-standing arrangement, the EUT was placed on the horizontal ground reference plane, but separated from metallic contact with the ground reference plane by 0.1m of insulation.
4. The test was performed with a vertical ground reference plane. The rear of the EUT shall be 0.4 m from the vertical ground reference plane. The vertical ground reference plane was bonded to the horizontal ground reference plane. The LISN was placed 0.8 m from the boundary of the unit under test and bonded to a ground reference plane for LISN mounted on top of the ground reference plane. This distance was between the closest points of the LISN and the EUT. The mains lead of EUT excess 0.8m was folded back and forth parallel to the lead so as to form a horizontal bundle with a length between 0.3m and 0.4m. All other units of the EUT and associated equipment were at least 0.8 m from the LISN.

Remark: Pre-scan was performed with peak detected on all ports, Quasi-peak & average measurements were performed at the frequencies at which maximum peak emission level were detected. Pretest under all modes; choose the worst case mode (GFSK and Hopping enabled mode) record on the report. Please see the attached Quasi-peak and Average test results.

**Test Result:** Pass

**Test Data:**

**Test Mode:** Hopping enabled mode

**Test Port:** AC Live Line

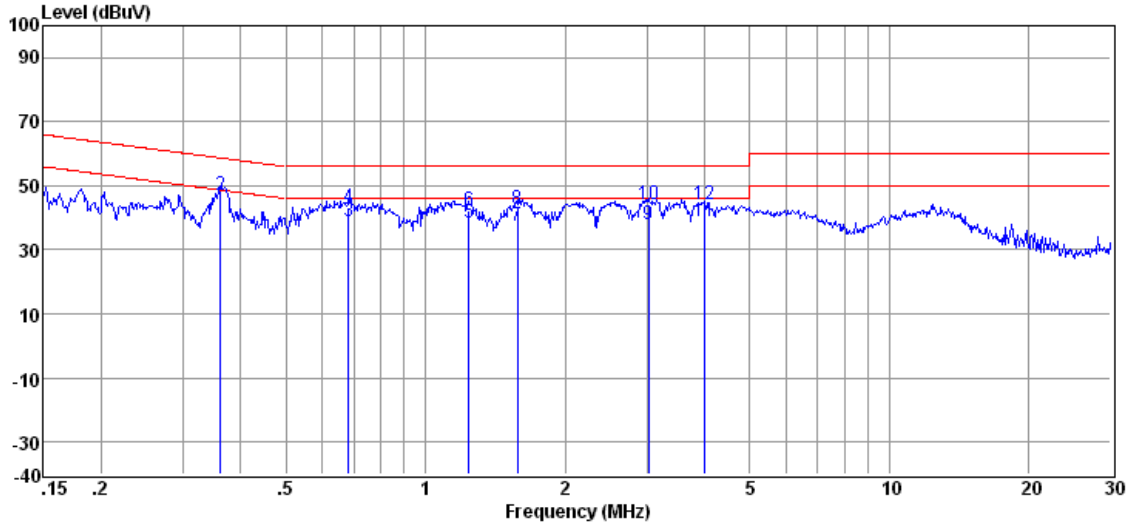

Item	Freq.	Read Level	LISN Factor	Cable Loss	Level	Limit Line	Over Limit	Detector
(Mark)	(MHz)	(dBμV)	(dB)	(dB)	(dBμV)	(dBμV)	(dB)	
1	0.361	41.69	0.25	0.10	42.04	48.69	-6.65	Average
2	0.361	46.69	0.25	0.10	47.04	58.69	-11.65	QP
3	0.683	38.78	0.22	0.10	39.10	46.00	-6.90	Average
4	0.683	42.78	0.22	0.10	43.10	56.00	-12.90	QP
5	1.242	37.93	0.23	0.10	38.26	46.00	-7.74	Average
6	1.242	41.93	0.23	0.10	42.26	56.00	-13.74	QP
7	1.577	37.16	0.30	0.10	37.56	46.00	-8.44	Average
8	1.577	42.16	0.30	0.10	42.56	56.00	-13.44	QP
9	3.025	37.56	0.37	0.15	38.08	46.00	-7.92	Average
10	3.025	43.56	0.37	0.15	44.08	56.00	-11.92	QP
11	3.985	38.56	0.38	0.18	39.12	46.00	-6.88	Average
12	3.985	43.56	0.38	0.18	44.12	56.00	-11.88	QP

**Test Mode:** Hopping enabled mode

**Test Port:** AC Neutral Line

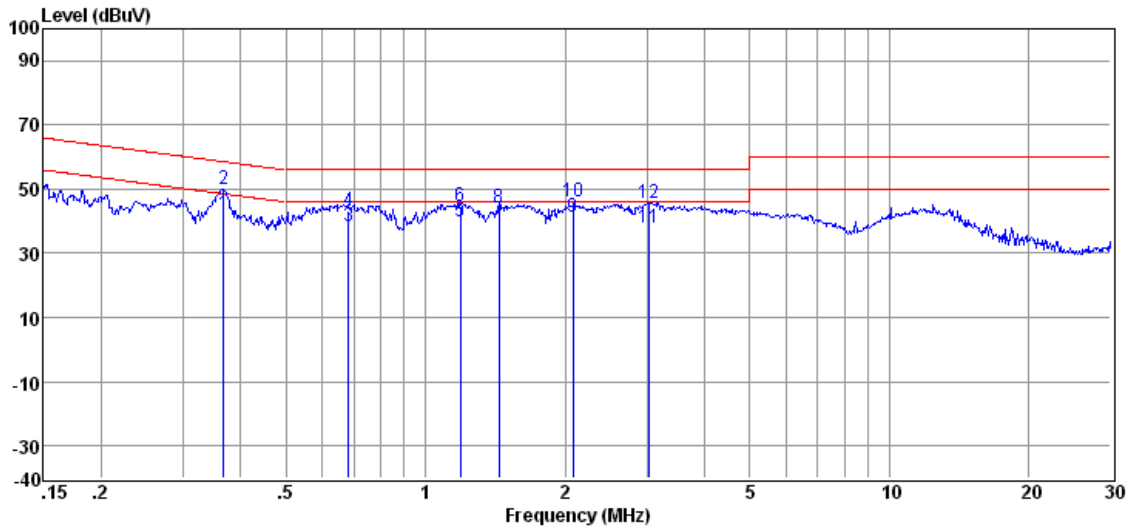

Item	Freq.	Read Level	LISN Factor	Cable Loss	Level	Limit Line	Over Limit	Detector
(Mark)	(MHz)	(dBμV)	(dB)	(dB)	(dBμV)	(dBμV)	(dB)	
1	0.367	41.76	0.30	0.10	42.16	48.56	-6.40	Average
2	0.367	49.76	0.30	0.10	50.16	58.56	-8.40	QP
3	0.683	38.00	0.20	0.10	38.30	46.00	-7.70	Average
4	0.683	43.00	0.20	0.10	43.30	56.00	-12.70	QP
5	1.191	39.13	0.42	0.10	39.65	46.00	-6.35	Average
6	1.191	44.13	0.42	0.10	44.65	56.00	-11.35	QP
7	1.441	39.61	0.64	0.10	40.35	46.00	-5.65	Average
8	1.441	43.61	0.64	0.10	44.35	56.00	-11.65	QP
9	2.077	40.21	0.97	0.10	41.28	46.00	-4.72	Average
10	2.077	45.21	0.97	0.10	46.28	56.00	-9.72	QP
11	3.041	36.93	0.73	0.15	37.81	46.00	-8.19	Average
12	3.041	44.93	0.73	0.15	45.81	56.00	-10.19	QP

Remark: Level = Read Level + LISN/ISN Factor + Cable Loss.



## 7.5 20dB Occupied Bandwidth

Test Configuration:

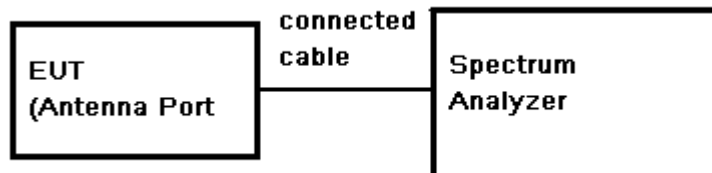

Test Procedure:

1. Remove the antenna from the EUT and then connect a low RF cable from the antenna port to the spectrum;
2. Set the spectrum analyzer: Span = approximately 2 to 3 times the 20dB bandwidth, centred on the hopping channel;
3. Set the spectrum analyzer: RBW  $\geq$  1% of the 20dB bandwidth (set 30 kHz). VBW  $\geq$  RBW. Sweep = auto; Detector Function = Peak. Trace = Max Hold.
4. Mark the peak frequency and -20dB points.

Test Result: PASS

Test date:

Test Channel	Channel Frequency(MHz)	Modulation	Bandwidth(MHz)
Low	2402	GFSK	1.044
Middle	2441	GFSK	1.041
High	2480	GFSK	1.044
Low	2402	$\pi/4$ DQPSK	1.098
Middle	2441	$\pi/4$ DQPSK	1.164
High	2480	$\pi/4$ DQPSK	1.161
Low	2402	8DPSK	1.188
Middle	2441	8DPSK	1.185
High	2480	8DPSK	1.179

**Test plot as follows:**

Test mode:	GFSK	Test channel:	Lowest
------------	------	---------------	--------



\*RBW 30 kHz Delta 3 [T1 ]  
 \*VBW 100 kHz 2.10 dB  
 \*SWT 340 ms 1.044000000 MHz  
 Ref 10 dBm Att 40 dB

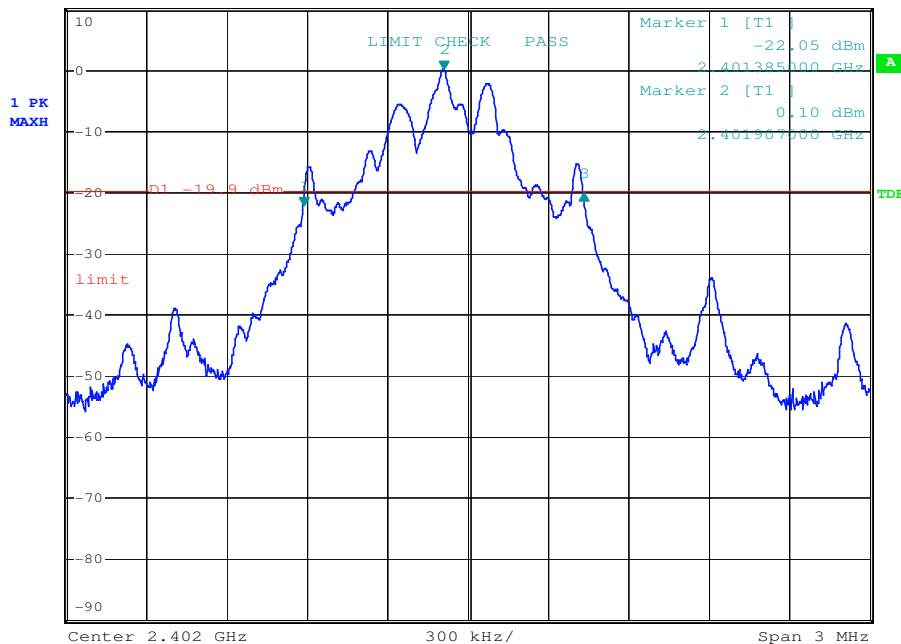

Test mode:	GFSK	Test channel:	Middle
------------	------	---------------	--------



\*RBW 30 kHz Delta 3 [T1 ]  
 \*VBW 100 kHz 0.42 dB  
 \*SWT 340 ms 1.041000000 MHz  
 Ref 10 dBm Att 40 dB

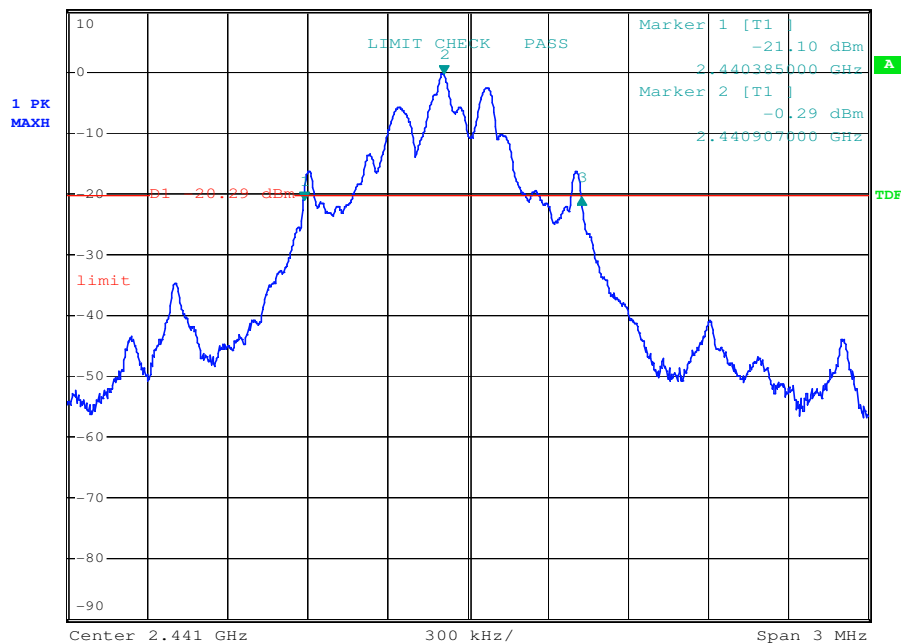

Test mode:	GFSK	Test channel:	Highest
------------	------	---------------	---------



Test mode:	$\pi/4$ DQPSK	Test channel:	Lowest
------------	---------------	---------------	--------

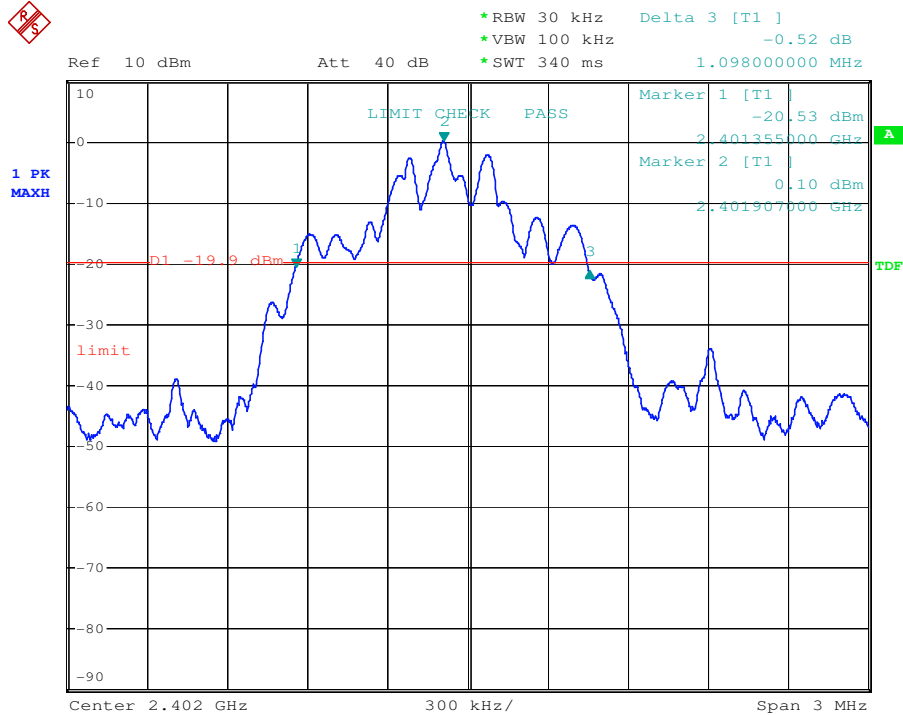

This document is issued by the Company subject to its General Conditions of Service printed overleaf, available on request or accessible at [www.sgs.com/terms\\_and\\_conditions.htm](http://www.sgs.com/terms_and_conditions.htm) and, for electronic format documents, subject to Terms and Conditions for Electronic Documents at [www.sgs.com/terms\\_e-document.htm](http://www.sgs.com/terms_e-document.htm). Attention is drawn to the limitation of liability, indemnification and jurisdiction issues defined therein. Any holder of this document is advised that information contained hereon reflects the Company's findings at the time of its intervention only and within the limits of Client's instructions, if any. The Company's sole responsibility is to its Client and this document does not exonerate parties to a transaction from exercising all their rights and obligations under the transaction documents. This document cannot be reproduced except in full, without prior written approval of the Company. Any unauthorized alteration, forgery or falsification of the content or appearance of this document is unlawful and offenders may be prosecuted to the fullest extent of the law. Unless otherwise stated the results shown in this test report refer only to the sample(s) tested and such sample(s) are retained for 90 days only

Test mode:	$\pi/4$ DQPSK	Test channel:	Middle
------------	---------------	---------------	--------

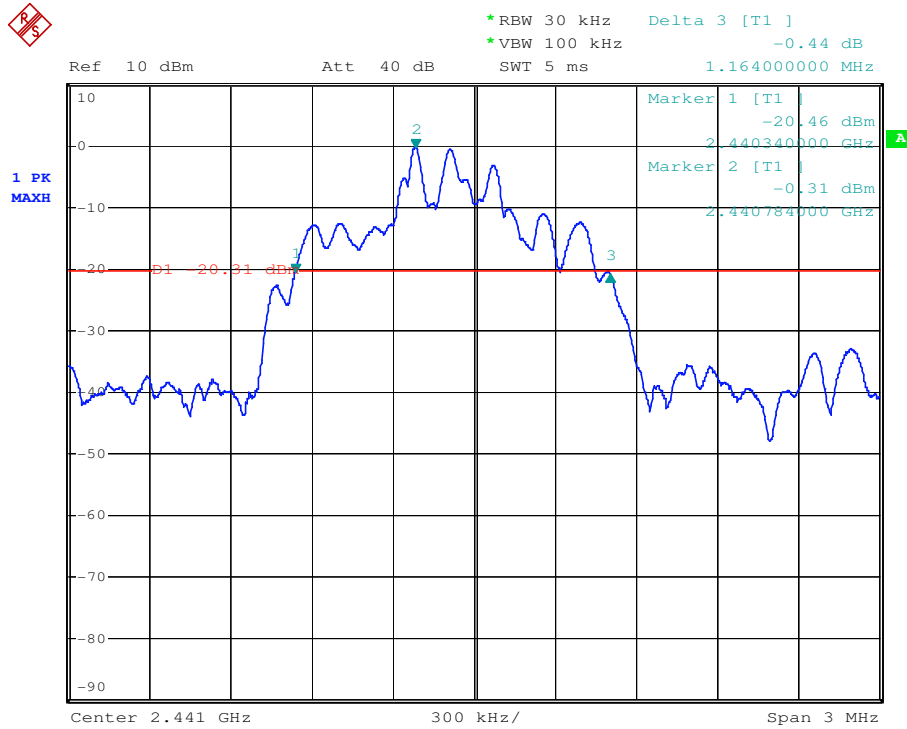

Test mode:	$\pi/4$ DQPSK	Test channel:	Highest
------------	---------------	---------------	---------

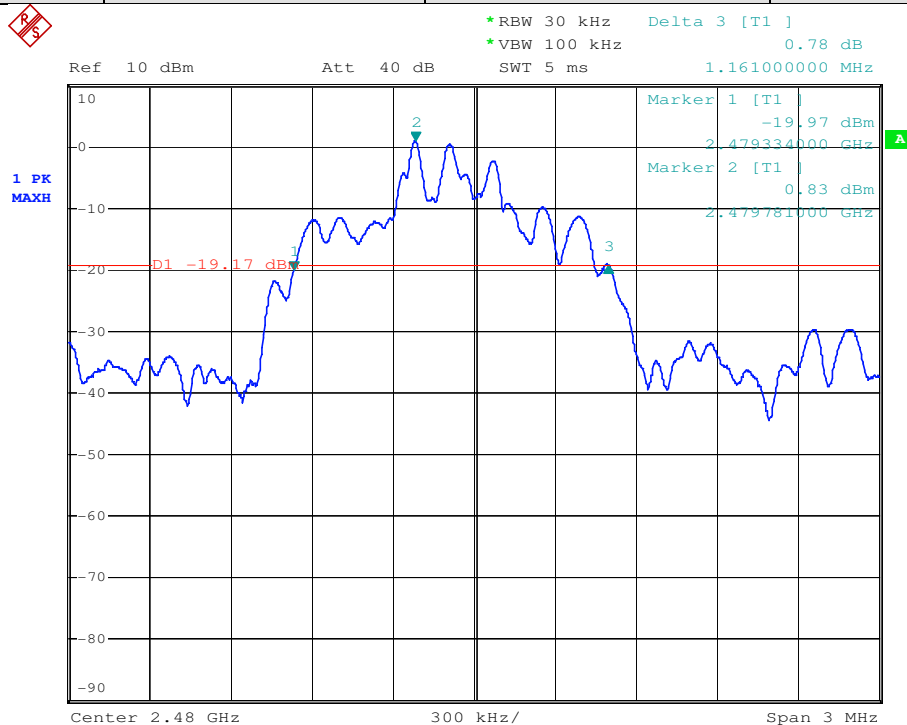

Test mode:	8DPSK	Test channel:	Lowest
------------	-------	---------------	--------

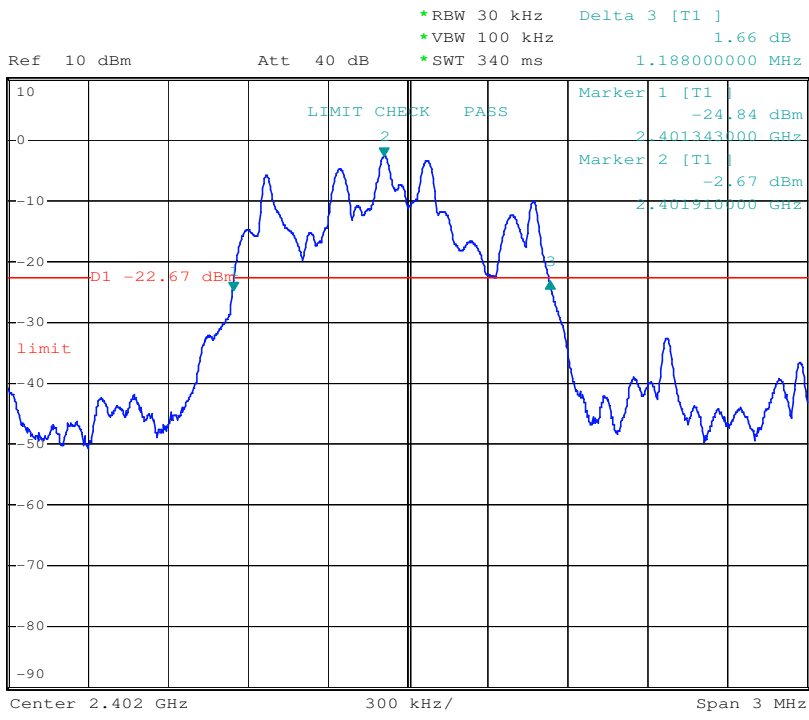

Test mode:	8DPSK	Test channel:	Middle
------------	-------	---------------	--------

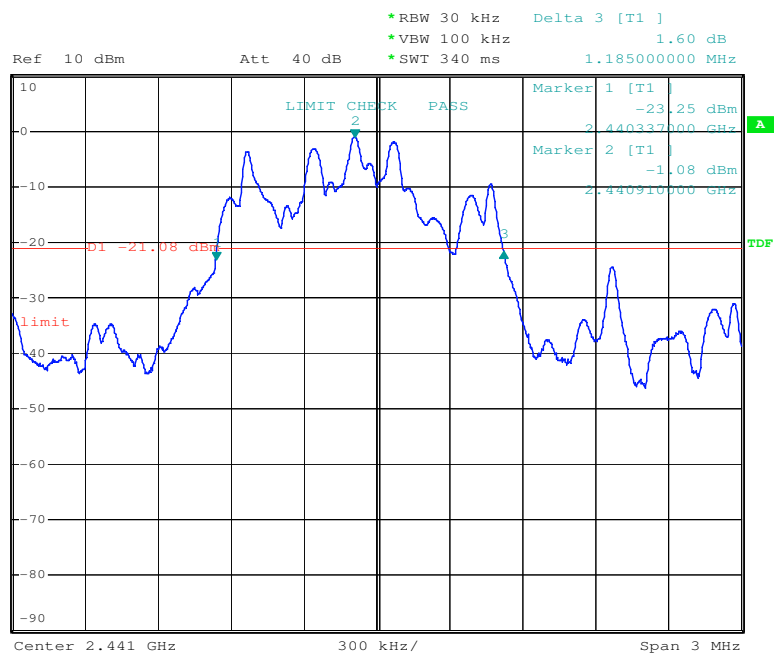

Date: 12.JUL.2014 11:23:26

This document is issued by the Company subject to its General Conditions of Service printed overleaf, available on request or accessible at [www.sgs.com/terms\\_and\\_conditions.htm](http://www.sgs.com/terms_and_conditions.htm) and, for electronic format documents, subject to Terms and Conditions for Electronic Documents at [www.sgs.com/terms\\_e-document.htm](http://www.sgs.com/terms_e-document.htm). Attention is drawn to the limitation of liability, indemnification and jurisdiction issues defined therein. Any holder of this document is advised that information contained hereon reflects the Company's findings at the time of its intervention only and within the limits of Client's instructions, if any. The Company's sole responsibility is to its Client and this document does not exonerate parties to a transaction from exercising all their rights and obligations under the transaction documents. This document cannot be reproduced except in full, without prior written approval of the Company. Any unauthorized alteration, forgery or falsification of the content or appearance of this document is unlawful and offenders may be prosecuted to the fullest extent of the law. Unless otherwise stated the results shown in this test report refer only to the sample(s) tested and such sample(s) are retained for 90 days only

Test mode:	8DPSK	Test channel:	Highest
------------	-------	---------------	---------

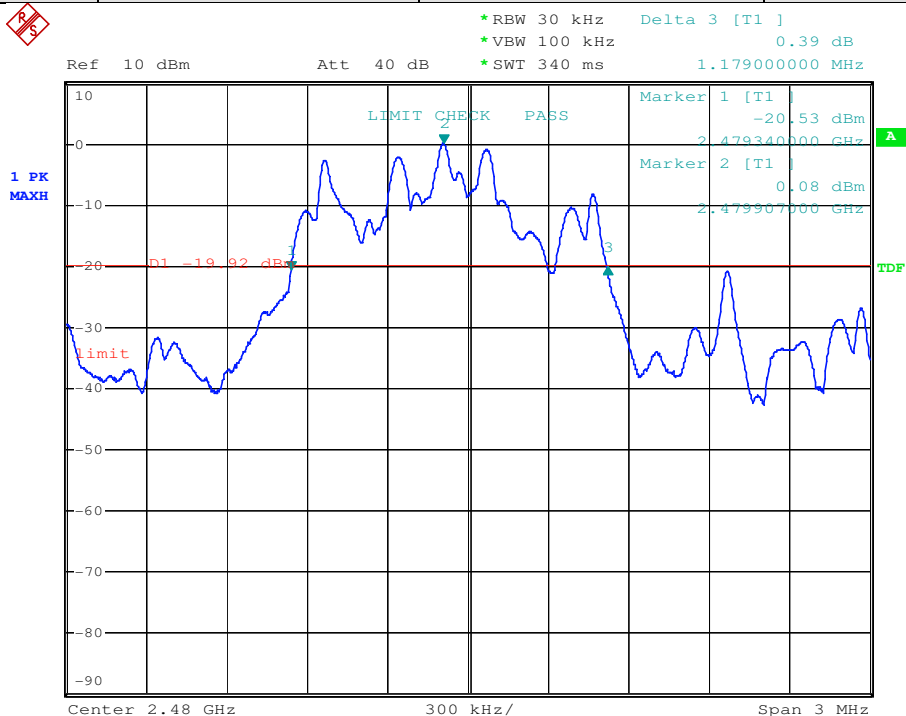

This document is issued by the Company subject to its General Conditions of Service printed overleaf, available on request or accessible at [www.sgs.com/terms\\_and\\_conditions.htm](http://www.sgs.com/terms_and_conditions.htm) and, for electronic format documents, subject to Terms and Conditions for Electronic Documents at [www.sgs.com/terms\\_e-document.htm](http://www.sgs.com/terms_e-document.htm). Attention is drawn to the limitation of liability, indemnification and jurisdiction issues defined therein. Any holder of this document is advised that information contained hereon reflects the Company's findings at the time of its intervention only and within the limits of Client's instructions, if any. The Company's sole responsibility is to its Client and this document does not exonerate parties to a transaction from exercising all their rights and obligations under the transaction documents. This document cannot be reproduced except in full, without prior written approval of the Company. Any unauthorized alteration, forgery or falsification of the content or appearance of this document is unlawful and offenders may be prosecuted to the fullest extent of the law. Unless otherwise stated the results shown in this test report refer only to the sample(s) tested and such sample(s) are retained for 90 days only

## 7.6 Conducted Peak Output Power

**Test Limit:**

Regulation 15.247 (b)(1) For frequency hopping systems operating in the 2400-2483.5 MHz band employing at least 75 non-overlapping hopping channels, and all frequency hopping systems in the 5725-5850 MHz band: 1 watt. For all other frequency hopping systems in the 2400-2483.5 MHz band: 0.125 watts.

Refer to the result "Hopping channel number" of this document. The 1 watt (30.0dBm) limit applies.

**Test Configuration:**

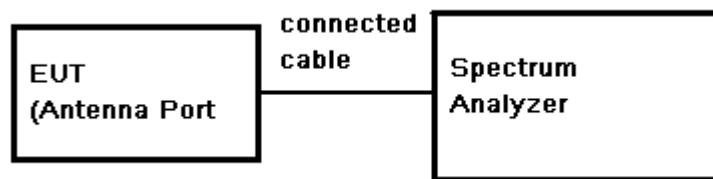

**Test Procedure:**

1. Remove the antenna from the EUT and then connect a low RF cable from the antenna port to the spectrum.
2. Set the spectrum analyzer: RBW = 3 MHz, VBW = 3 MHz, Sweep = auto; Detector Function = Peak.
3. Keep the EUT in transmitting at lowest, middle and highest channel individually. Record the max value.

**Test Result:** Pass

**Test Data:**

Test Channel	Modulation	Fundamental Frequency (MHz)	Reading Power (dBm)	Cable Loss (dB)	Output Power (dBm)	Limit (dBm)	Margin (dB)
Lowest	GFSK	2402	-1.78	0.5	-1.28	30	31.28
Middle	GFSK	2441	0.62	0.5	1.12	30	28.88
Highest	GFSK	2480	1.13	0.5	1.63	30	28.37
Lowest	$\pi/4$ DQPSK	2402	-1.30	0.5	-0.8	30	30.8
Middle	$\pi/4$ DQPSK	2441	0.08	0.5	0.58	30	29.42
Highest	$\pi/4$ DQPSK	2480	0.71	0.5	1.21	30	28.79
Lowest	8DPSK	2402	-0.94	0.5	-0.44	30	30.44
Middle	8DPSK	2441	0.08	0.5	0.58	30	29.42
Highest	8DPSK	2480	0.76	0.5	1.26	30	28.74

Remark: Output Power=Reading Power + Cable loss



**Test result plot as follows:**

Test mode:	GFSK	Test channel:	Lowest
------------	------	---------------	--------

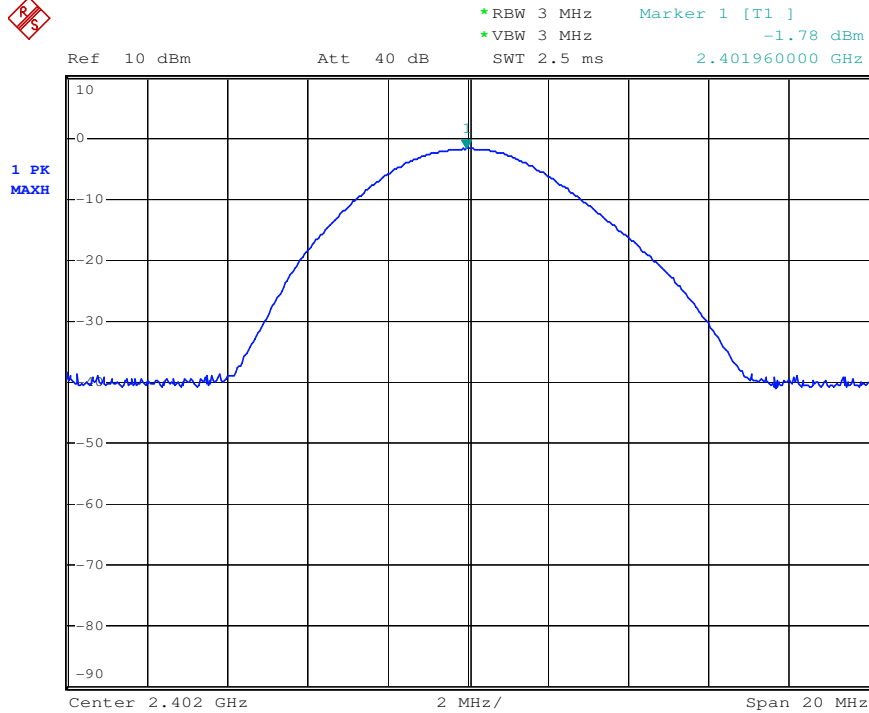

Test mode:	GFSK	Test channel:	Middle
------------	------	---------------	--------

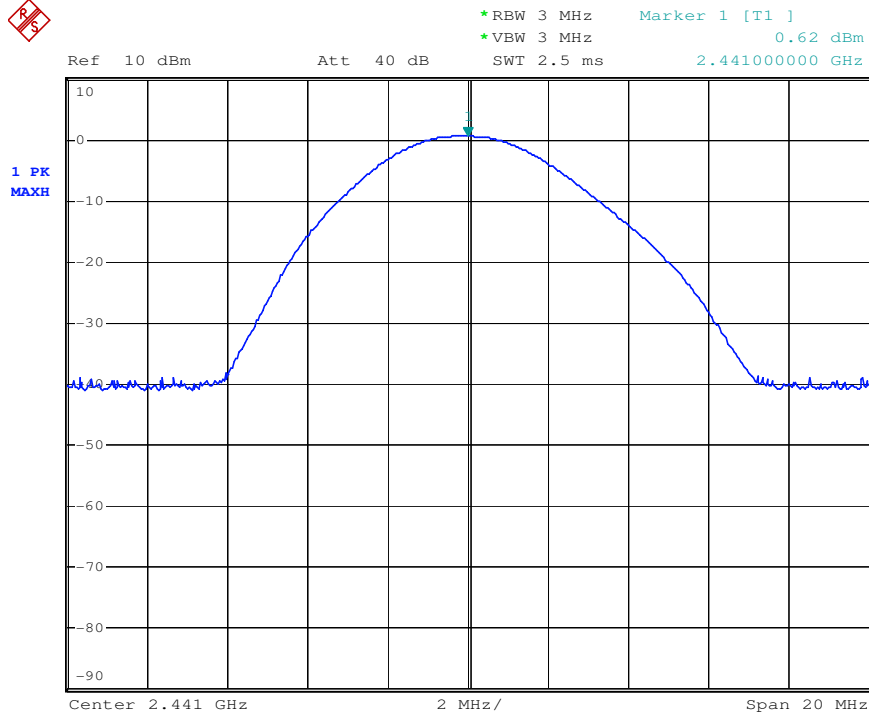

This document is issued by the Company subject to its General Conditions of Service printed overleaf, available on request or accessible at [www.sgs.com/terms\\_and\\_conditions.htm](http://www.sgs.com/terms_and_conditions.htm) and, for electronic format documents, subject to Terms and Conditions for Electronic Documents at [www.sgs.com/terms\\_e-document.htm](http://www.sgs.com/terms_e-document.htm). Attention is drawn to the limitation of liability, indemnification and jurisdiction issues defined therein. Any holder of this document is advised that information contained hereon reflects the Company's findings at the time of its intervention only and within the limits of Client's instructions, if any. The Company's sole responsibility is to its Client and this document does not exonerate parties to a transaction from exercising all their rights and obligations under the transaction documents. This document cannot be reproduced except in full, without prior written approval of the Company. Any unauthorized alteration, forgery or falsification of the content or appearance of this document is unlawful and offenders may be prosecuted to the fullest extent of the law. Unless otherwise stated the results shown in this test report refer only to the sample(s) tested and such sample(s) are retained for 90 days only

Test mode:	GFSK	Test channel:	Highest
------------	------	---------------	---------

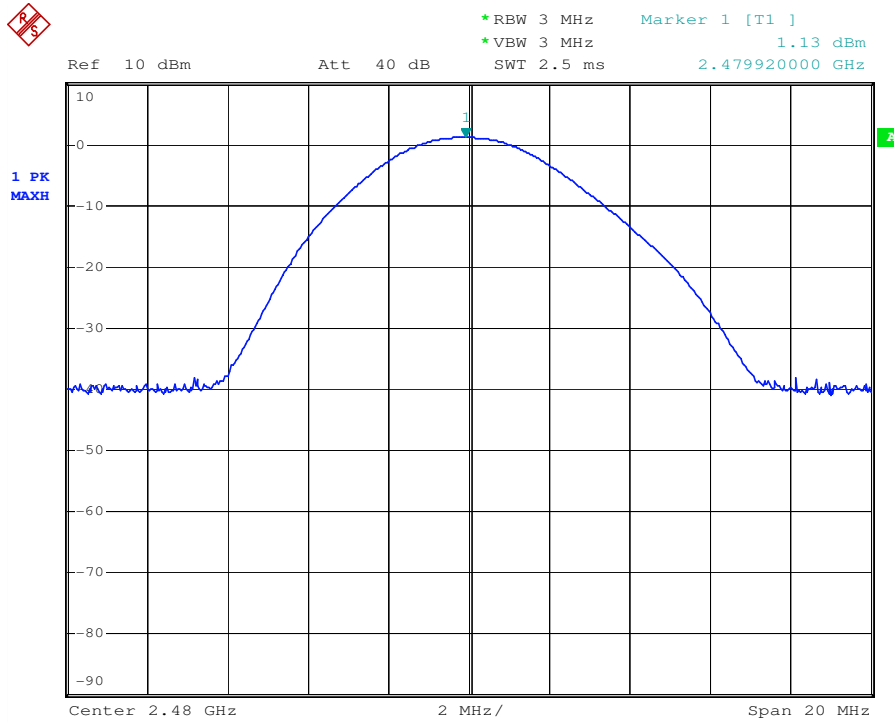

Test mode:	$\pi/4$ DQPSK	Test channel:	Lowest
------------	---------------	---------------	--------

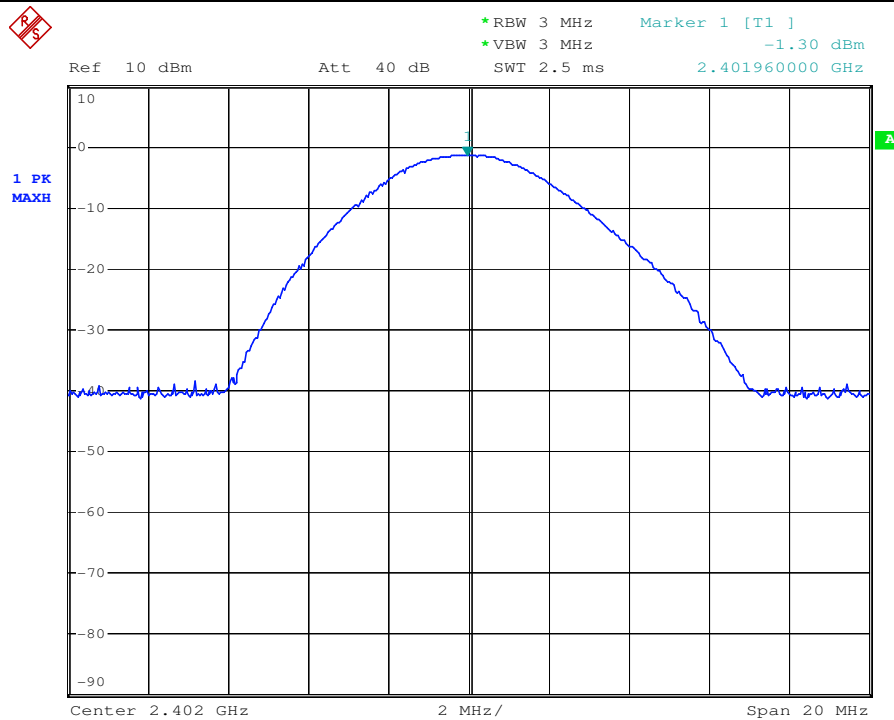

This document is issued by the Company subject to its General Conditions of Service printed overleaf, available on request or accessible at [www.sgs.com/terms\\_and\\_conditions.htm](http://www.sgs.com/terms_and_conditions.htm) and, for electronic format documents, subject to Terms and Conditions for Electronic Documents at [www.sgs.com/terms\\_e-document.htm](http://www.sgs.com/terms_e-document.htm). Attention is drawn to the limitation of liability, indemnification and jurisdiction issues defined therein. Any holder of this document is advised that information contained hereon reflects the Company's findings at the time of its intervention only and within the limits of Client's instructions, if any. The Company's sole responsibility is to its Client and this document does not exonerate parties to a transaction from exercising all their rights and obligations under the transaction documents. This document cannot be reproduced except in full, without prior written approval of the Company. Any unauthorized alteration, forgery or falsification of the content or appearance of this document is unlawful and offenders may be prosecuted to the fullest extent of the law. Unless otherwise stated the results shown in this test report refer only to the sample(s) tested and such sample(s) are retained for 90 days only

Test mode:	$\pi/4$ DQPSK	Test channel:	Middle
------------	---------------	---------------	--------



Ref 10 dBm Att 40 dB \*RBW 3 MHz Marker 1 [T1 ]  
\*VBW 3 MHz 0.08 dBm  
SWT 2.5 ms 2.440680000 GHz

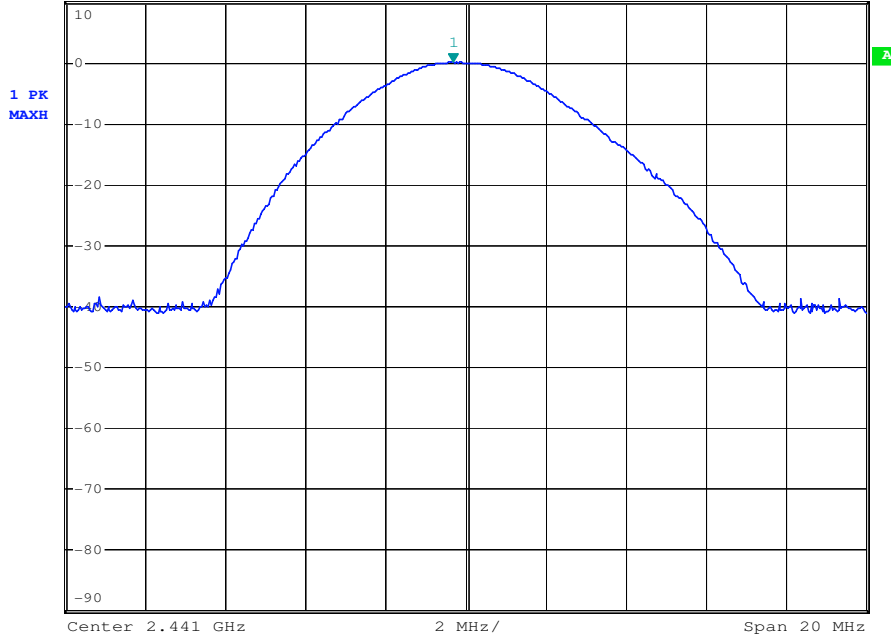

Test mode:	$\pi/4$ DQPSK	Test channel:	Highest
------------	---------------	---------------	---------



Ref 10 dBm Att 40 dB \*RBW 3 MHz Marker 1 [T1 ]  
\*VBW 3 MHz 0.71 dBm  
SWT 2.5 ms 2.479760000 GHz

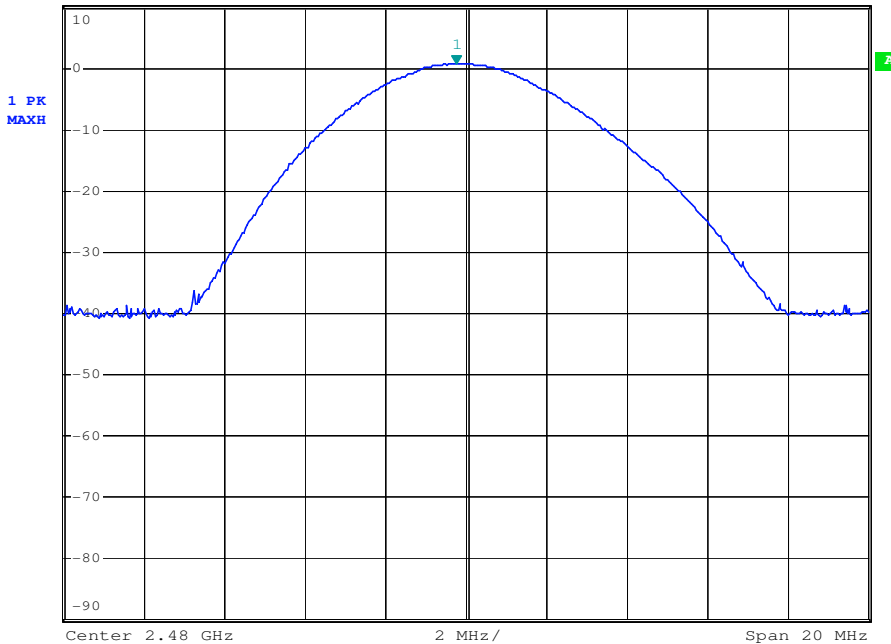

This document is issued by the Company subject to its General Conditions of Service printed overleaf, available on request or accessible at [www.sgs.com/terms\\_and\\_conditions.htm](http://www.sgs.com/terms_and_conditions.htm) and, for electronic format documents, subject to Terms and Conditions for Electronic Documents at [www.sgs.com/terms\\_e-document.htm](http://www.sgs.com/terms_e-document.htm). Attention is drawn to the limitation of liability, indemnification and jurisdiction issues defined therein. Any holder of this document is advised that information contained hereon reflects the Company's findings at the time of its intervention only and within the limits of Client's instructions, if any. The Company's sole responsibility is to its Client and this document does not exonerate parties to a transaction from exercising all their rights and obligations under the transaction documents. This document cannot be reproduced except in full, without prior written approval of the Company. Any unauthorized alteration, forgery or falsification of the content or appearance of this document is unlawful and offenders may be prosecuted to the fullest extent of the law. Unless otherwise stated the results shown in this test report refer only to the sample(s) tested and such sample(s) are retained for 90 days only



Test mode:	8DPSK	Test channel:	Lowest
------------	-------	---------------	--------



Ref 10 dBm Att 40 dB \*RBW 3 MHz Marker 1 [T1 ]  
\*VBW 3 MHz -0.94 dBm  
SWT 2.5 ms 2.401880000 GHz

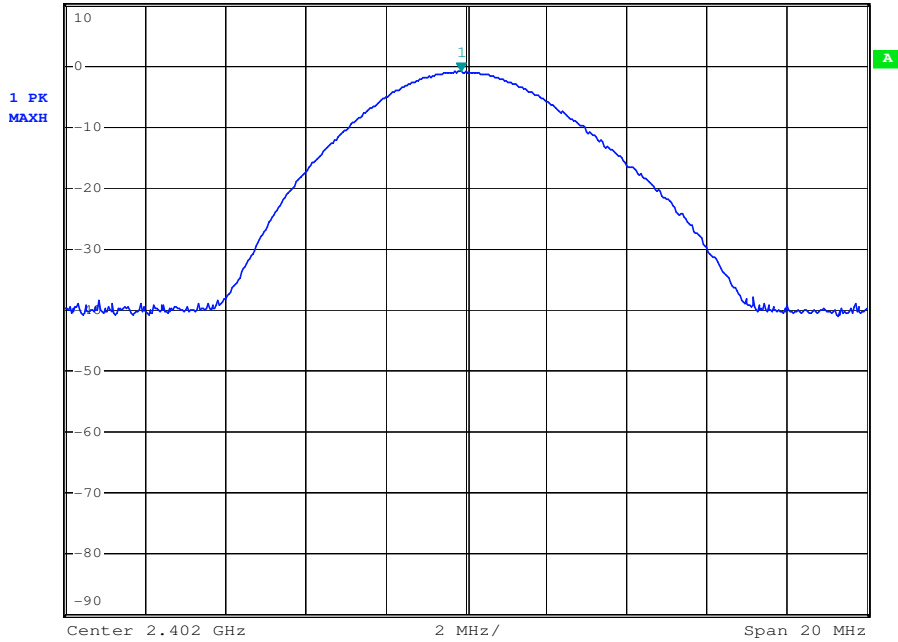

Test mode:	8DPSK	Test channel:	Middle
------------	-------	---------------	--------



Ref 10 dBm Att 40 dB \*RBW 3 MHz Marker 1 [T1 ]  
\*VBW 3 MHz 0.08 dBm  
SWT 2.5 ms 2.440880000 GHz

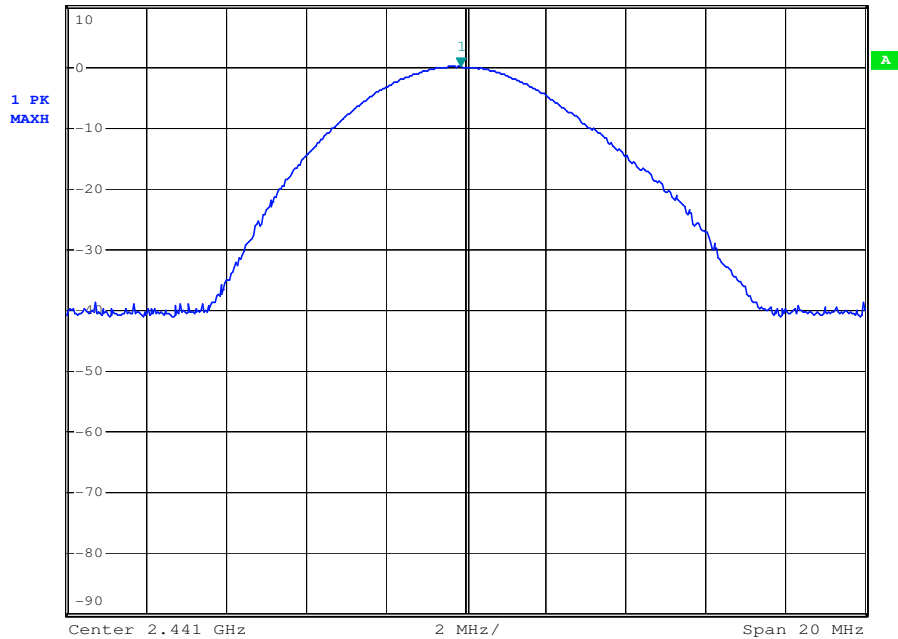

This document is issued by the Company subject to its General Conditions of Service printed overleaf, available on request or accessible at [www.sgs.com/terms\\_and\\_conditions.htm](http://www.sgs.com/terms_and_conditions.htm) and, for electronic format documents, subject to Terms and Conditions for Electronic Documents at [www.sgs.com/terms\\_e-document.htm](http://www.sgs.com/terms_e-document.htm). Attention is drawn to the limitation of liability, indemnification and jurisdiction issues defined therein. Any holder of this document is advised that information contained hereon reflects the Company's findings at the time of its intervention only and within the limits of Client's instructions, if any. The Company's sole responsibility is to its Client and this document does not exonerate parties to a transaction from exercising all their rights and obligations under the transaction documents. This document cannot be reproduced except in full, without prior written approval of the Company. Any unauthorized alteration, forgery or falsification of the content or appearance of this document is unlawful and offenders may be prosecuted to the fullest extent of the law. Unless otherwise stated the results shown in this test report refer only to the sample(s) tested and such sample(s) are retained for 90 days only

Test mode:	8DPSK	Test channel:	Highest
------------	-------	---------------	---------



\*RBW 3 MHz      Marker 1 [T1 ]  
\*VBW 3 MHz      0.76 dBm  
SWT 2.5 ms      2.479760000 GHz

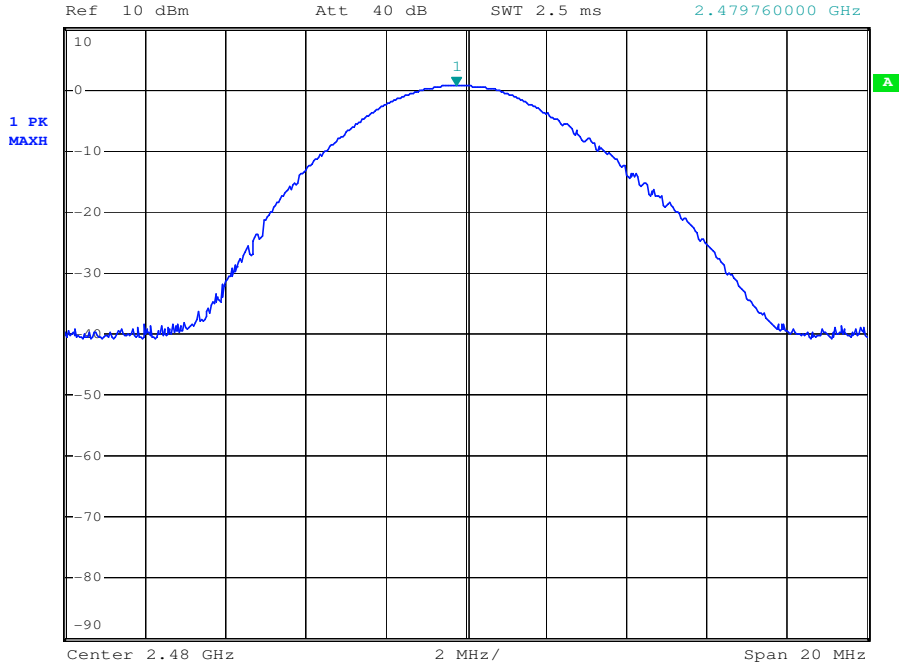

This document is issued by the Company subject to its General Conditions of Service printed overleaf, available on request or accessible at [www.sgs.com/terms\\_and\\_conditions.htm](http://www.sgs.com/terms_and_conditions.htm) and, for electronic format documents, subject to Terms and Conditions for Electronic Documents at [www.sgs.com/terms\\_e-document.htm](http://www.sgs.com/terms_e-document.htm). Attention is drawn to the limitation of liability, indemnification and jurisdiction issues defined therein. Any holder of this document is advised that information contained hereon reflects the Company's findings at the time of its intervention only and within the limits of Client's instructions, if any. The Company's sole responsibility is to its Client and this document does not exonerate parties to a transaction from exercising all their rights and obligations under the transaction documents. This document cannot be reproduced except in full, without prior written approval of the Company. Any unauthorized alteration, forgery or falsification of the content or appearance of this document is unlawful and offenders may be prosecuted to the fullest extent of the law. Unless otherwise stated the results shown in this test report refer only to the sample(s) tested and such sample(s) are retained for 90 days only

## 7.7 Carrier Frequencies Separated

**Limit:** 0.025MHz or 2/3 of the 20dB bandwidth (whichever is greater)

**Test Configuration:**

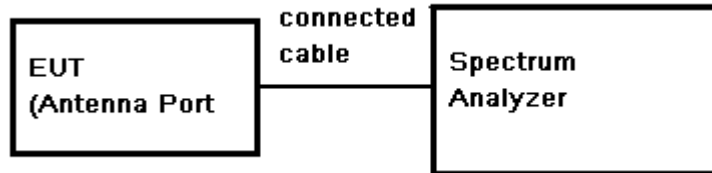

**Test Procedure:**

1. Remove the antenna from the EUT and then connect a low RF cable from the antenna port to the spectrum.
2. Set the spectrum analyzer: RBW  $\geq$  1% of the span (set 30 kHz). VBW  $\geq$  RBW, Span = 3MHz. Sweep = auto; Detector Function = Peak. Trace = Maxhold.
3. Allow the trace to stabilize. Use the marker-delta function to determine the separation between the peaks of the adjacent channels. The limit is specified in one of the subparagraphs of this Section. Submit this plot.

**Test result:** Pass

**Test data:**

Test Channel	Modulation	Carrier Frequencies Separated (MHz)	Limit (25kHz or two-thirds of the 20 dB bandwidth)	Results
Middle Channels (channel 39 and channel 40)	GFSK	0.996	25kHz/696kHz	PASS
Middle Channels (channel 39 and channel 40)	$\pi/4$ DQPSK	1.008	25kHz/744kHz	PASS
Middle Channels (channel 39 and channel 40)	8DPSK	0.996	25kHz/792kHz	PASS

- Remark: 1. According to the section 7.6, the conducted power measured is less than 125mW and 2/3 of 20dB bandwidth is used for limit.  
2. 20dB bandwidth reference Section 7.5

**Test plot as follows:**

Test mode:	GFSK	Test channel:	Middle
------------	------	---------------	--------

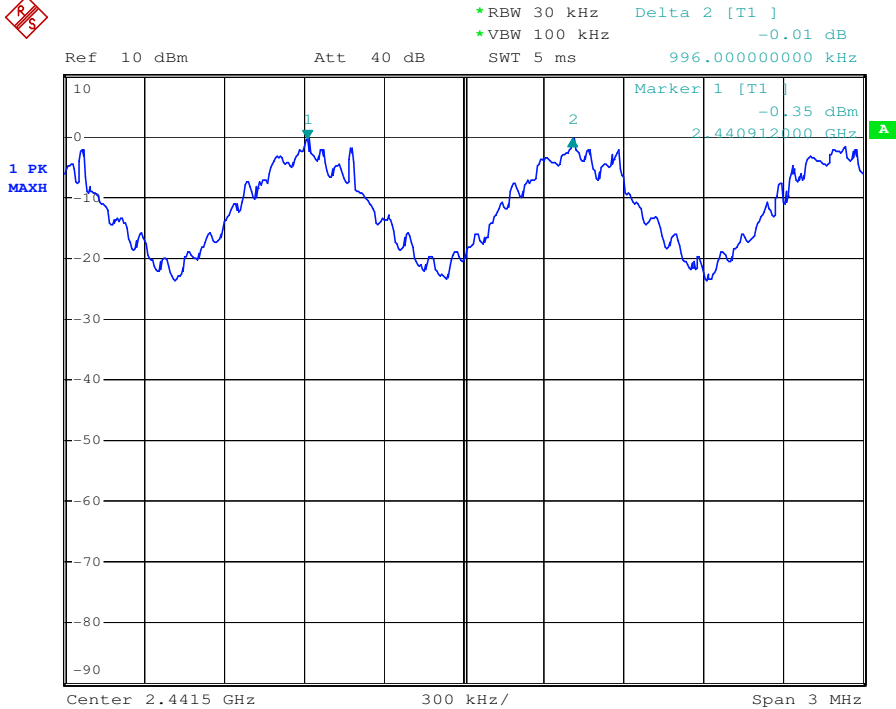

Test mode:	$\pi/4$ DQPSK	Test channel:	Middle
------------	---------------	---------------	--------

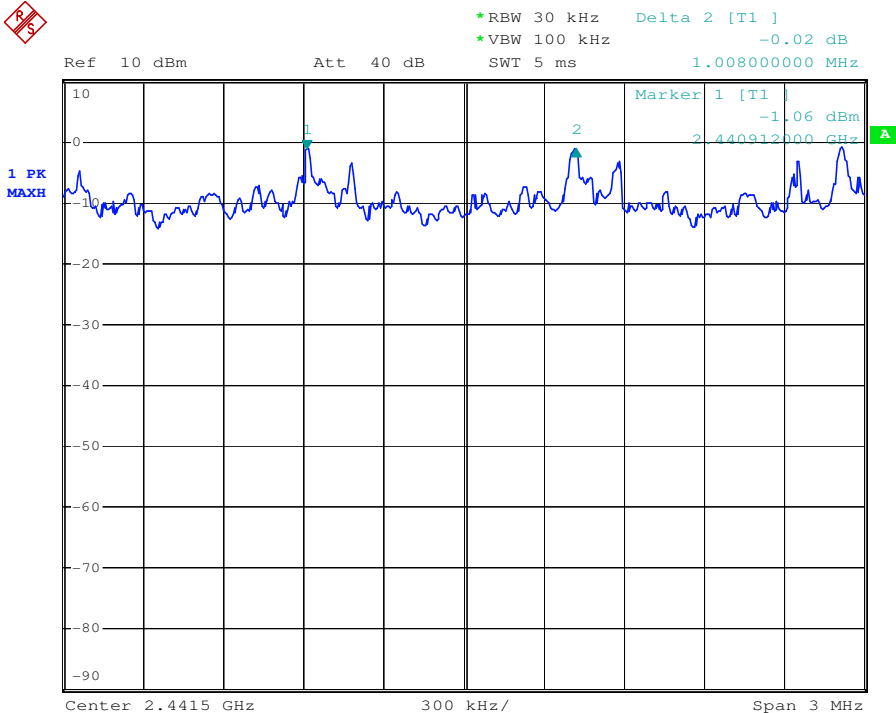

This document is issued by the Company subject to its General Conditions of Service printed overleaf, available on request or accessible at [www.sgs.com/terms\\_and\\_conditions.htm](http://www.sgs.com/terms_and_conditions.htm) and, for electronic format documents, subject to Terms and Conditions for Electronic Documents at [www.sgs.com/terms\\_e-document.htm](http://www.sgs.com/terms_e-document.htm). Attention is drawn to the limitation of liability, indemnification and jurisdiction issues defined therein. Any holder of this document is advised that information contained hereon reflects the Company's findings at the time of its intervention only and within the limits of Client's instructions, if any. The Company's sole responsibility is to its Client and this document does not exonerate parties to a transaction from exercising all their rights and obligations under the transaction documents. This document cannot be reproduced except in full, without prior written approval of the Company. Any unauthorized alteration, forgery or falsification of the content or appearance of this document is unlawful and offenders may be prosecuted to the fullest extent of the law. Unless otherwise stated the results shown in this test report refer only to the sample(s) tested and such sample(s) are retained for 90 days only



Test mode:	8DPSK	Test channel:	Middle
------------	-------	---------------	--------

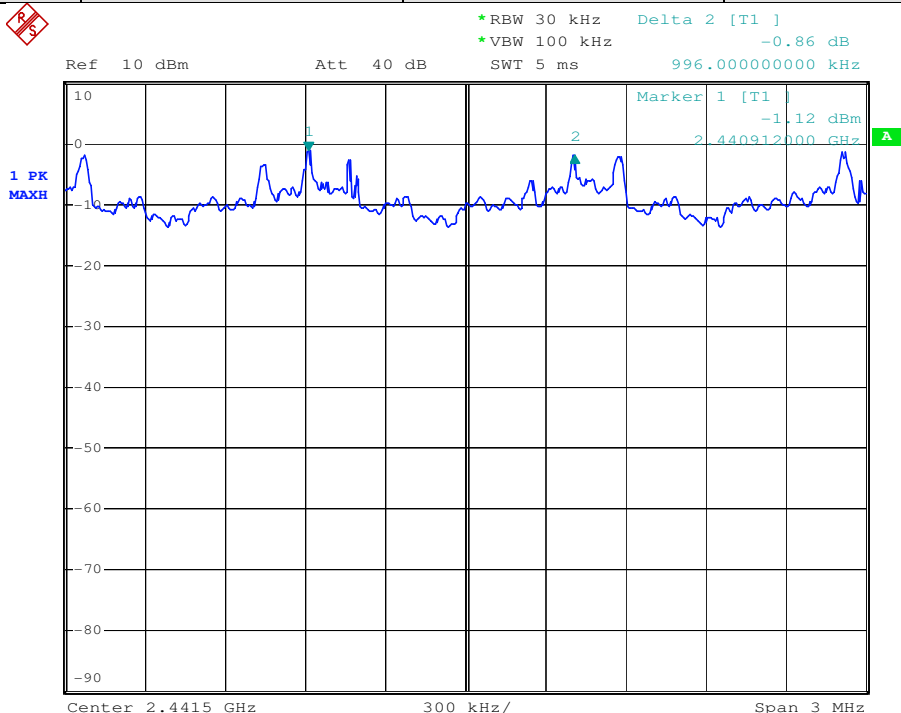

This document is issued by the Company subject to its General Conditions of Service printed overleaf, available on request or accessible at [www.sgs.com/terms\\_and\\_conditions.htm](http://www.sgs.com/terms_and_conditions.htm) and, for electronic format documents, subject to Terms and Conditions for Electronic Documents at [www.sgs.com/terms\\_e-document.htm](http://www.sgs.com/terms_e-document.htm). Attention is drawn to the limitation of liability, indemnification and jurisdiction issues defined therein. Any holder of this document is advised that information contained hereon reflects the Company's findings at the time of its intervention only and within the limits of Client's instructions, if any. The Company's sole responsibility is to its Client and this document does not exonerate parties to a transaction from exercising all their rights and obligations under the transaction documents. This document cannot be reproduced except in full, without prior written approval of the Company. Any unauthorized alteration, forgery or falsification of the content or appearance of this document is unlawful and offenders may be prosecuted to the fullest extent of the law. Unless otherwise stated the results shown in this test report refer only to the sample(s) tested and such sample(s) are retained for 90 days only



## 7.8 Hopping Channel Number

**Limit:** At least 15 channels

**Test Configuration:**

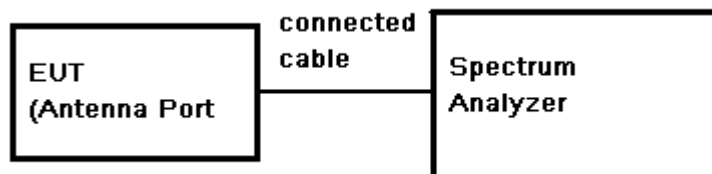

**Test Procedure:**

1. Remove the antenna from the EUT and then connect a low RF cable from the antenna port to the spectrum.
2. Set the spectrum analyzer: RBW = 100 kHz. VBW = 100 kHz. Sweep = auto; Detector Function = Peak. Trace = Max hold.
3. Allow the trace to stabilize. It may prove necessary to break the span up to sections. in order to clearly show all of the hopping frequencies. The limit is specified in one of the subparagraphs of this Section.
4. Set the spectrum analyzer: start frequency = 2400MHz. stop frequency = 2483.5MHz. Submit the test result graph.

**Test Result:** Pass

**Test Data:**

Mode	Hopping channel numbers	Limit	Results
8DPSK	79	≥15	Pass
GFSK	79	≥15	Pass
$\pi/4$ DQPSK	79	≥15	Pass

**Test plot as follows:**

Test mode:	GFSK	Test channel:	Middle
------------	------	---------------	--------

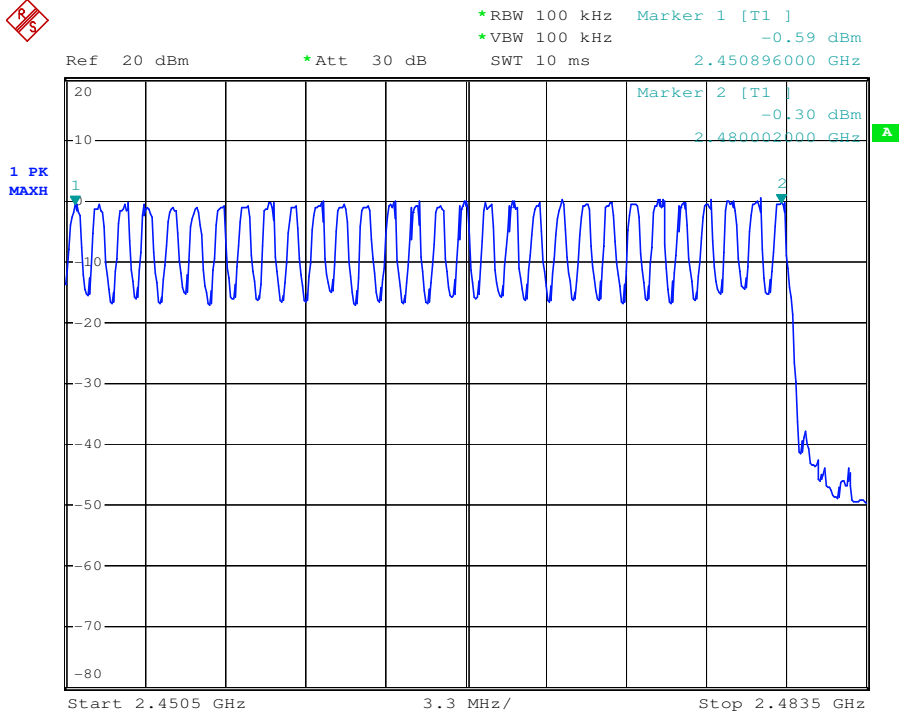
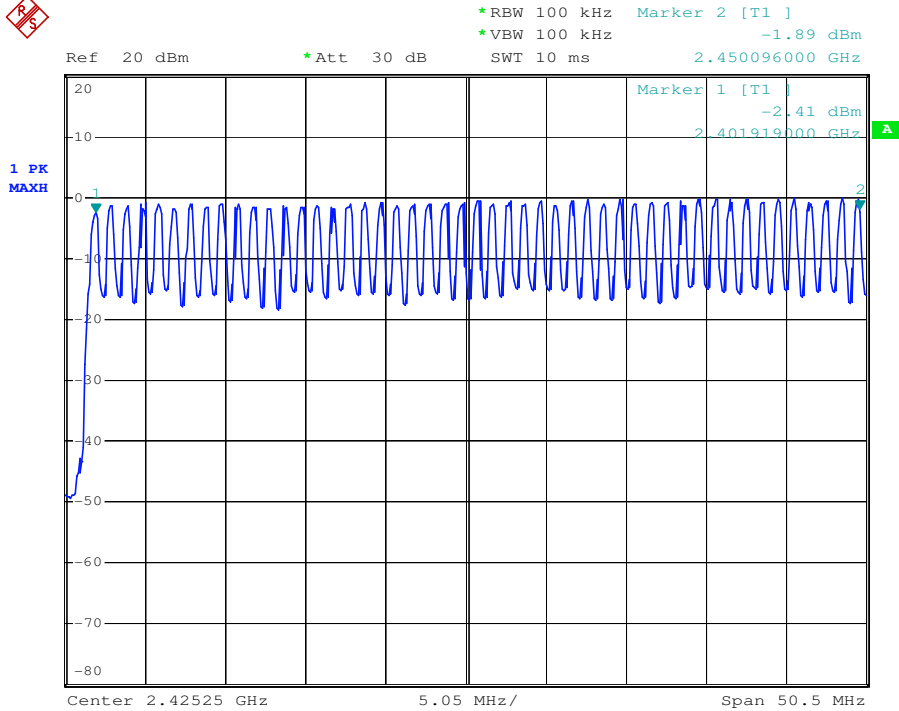

This document is issued by the Company subject to its General Conditions of Service printed overleaf, available on request or accessible at [www.sgs.com/terms\\_and\\_conditions.htm](http://www.sgs.com/terms_and_conditions.htm) and, for electronic format documents, subject to Terms and Conditions for Electronic Documents at [www.sgs.com/terms\\_e-document.htm](http://www.sgs.com/terms_e-document.htm). Attention is drawn to the limitation of liability, indemnification and jurisdiction issues defined therein. Any holder of this document is advised that information contained hereon reflects the Company's findings at the time of its intervention only and within the limits of Client's instructions, if any. The Company's sole responsibility is to its Client and this document does not exonerate parties to a transaction from exercising all their rights and obligations under the transaction documents. This document cannot be reproduced except in full, without prior written approval of the Company. Any unauthorized alteration, forgery or falsification of the content or appearance of this document is unlawful and offenders may be prosecuted to the fullest extent of the law. Unless otherwise stated the results shown in this test report refer only to the sample(s) tested and such sample(s) are retained for 90 days only



Test mode:	8DPSK	Test channel:	Middle
------------	-------	---------------	--------

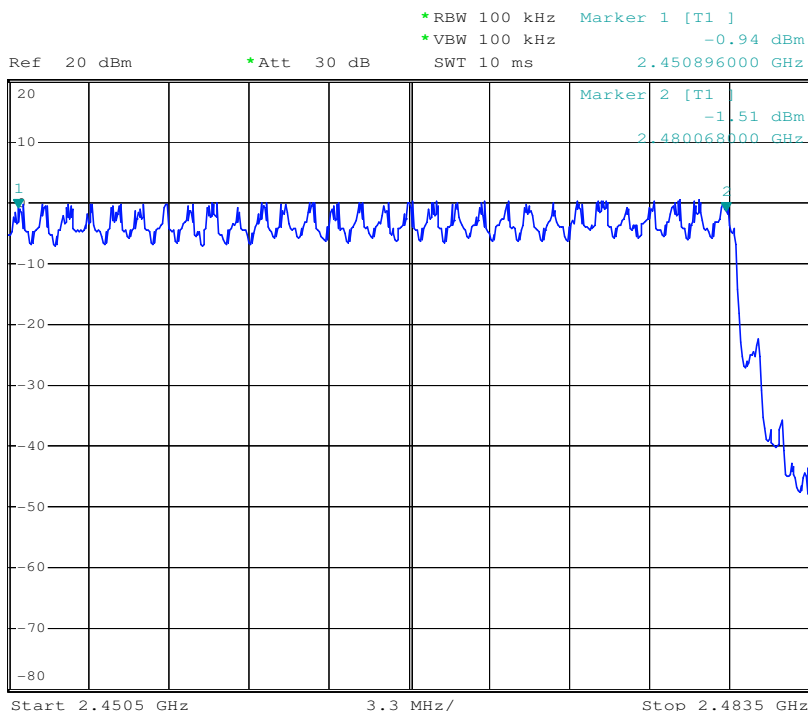
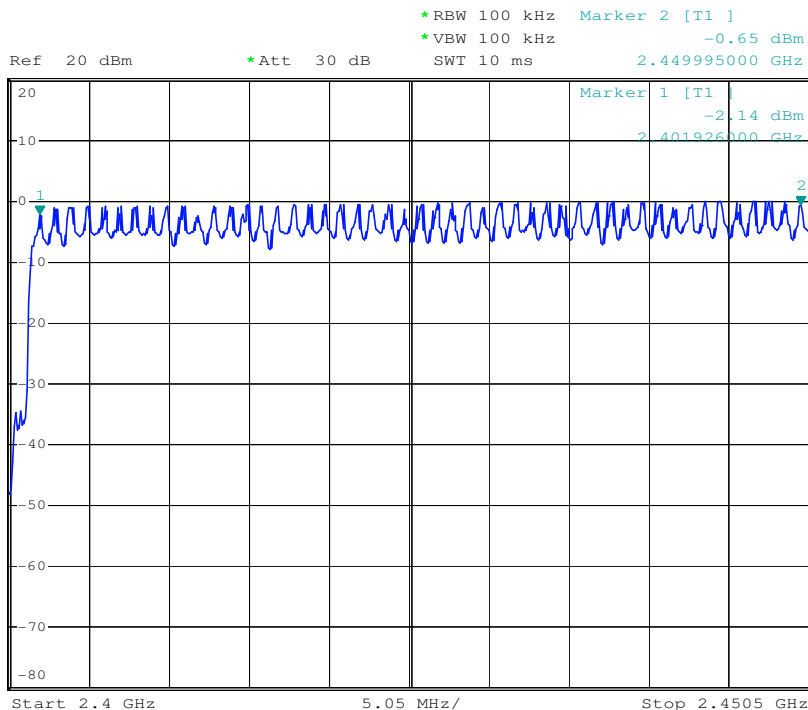

This document is issued by the Company subject to its General Conditions of Service printed overleaf, available on request or accessible at [www.sgs.com/terms\\_and\\_conditions.htm](http://www.sgs.com/terms_and_conditions.htm) and, for electronic format documents, subject to Terms and Conditions for Electronic Documents at [www.sgs.com/terms\\_e-document.htm](http://www.sgs.com/terms_e-document.htm). Attention is drawn to the limitation of liability, indemnification and jurisdiction issues defined therein. Any holder of this document is advised that information contained hereon reflects the Company's findings at the time of its intervention only and within the limits of Client's instructions, if any. The Company's sole responsibility is to its Client and this document does not exonerate parties to a transaction from exercising all their rights and obligations under the transaction documents. This document cannot be reproduced except in full, without prior written approval of the Company. Any unauthorized alteration, forgery or falsification of the content or appearance of this document is unlawful and offenders may be prosecuted to the fullest extent of the law. Unless otherwise stated the results shown in this test report refer only to the sample(s) tested and such sample(s) are retained for 90 days only

## 7.9 Dwell Time

**Limit:** Regulation 15.247(a)(1)(iii) Frequency hopping systems in the 2400-2483.5 MHz band shall use at least 15 channels. The average time of occupancy on any channel shall not be greater than 0.4 seconds within a period of 0.4 seconds multiplied by the number of hopping channels employed. Frequency hopping systems may avoid or suppress transmissions on a particular hopping frequency provided that a minimum of 15 channels are used.

**Test Configuration:**

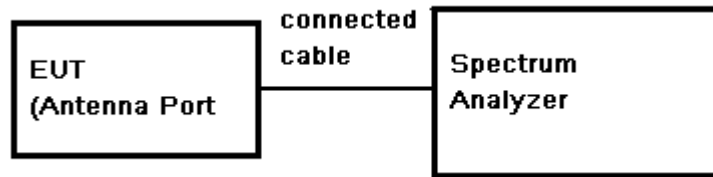

**Test Procedure:**

1. Remove the antenna from the EUT and then connect a low RF cable from the antenna port to the spectrum. Keep EUT in Hopping transmitting with all kind of modulation.
2. Set spectrum analyzer span = 0. centered on a hopping channel;
3. Use Emission width \* No. of Hopping Channels in 31.6s to determine the dwell time.

**Test Result:** Pass

**Test Data:**

Frequency (MHz)	Modulation	Packet	Emission Width (ms)	Number of Hopping Channel in 31.6s	Average Time of Occupancy(s)	Limit(s)	Result
2441	GFSK	DH1	0.391	320	0.13	0.4	Pass
		DH3	1.639	160	0.26	0.4	Pass
		DH5	2.887	110	0.32	0.4	Pass
	π/4DQPSK	DH1	0.391	320	0.13	0.4	Pass
		DH3	1.500	160	0.24	0.4	Pass
		DH5	1.548	160	0.25	0.4	Pass
	8DPSK	DH1	0.396	320	0.13	0.4	Pass
		DH3	1.644	160	0.26	0.4	Pass
		DH5	2.892	110	0.32	0.4	Pass

**Test plot as follows:**

Test mode:	GFSK-DH1	Test channel:	Middle
------------	----------	---------------	--------

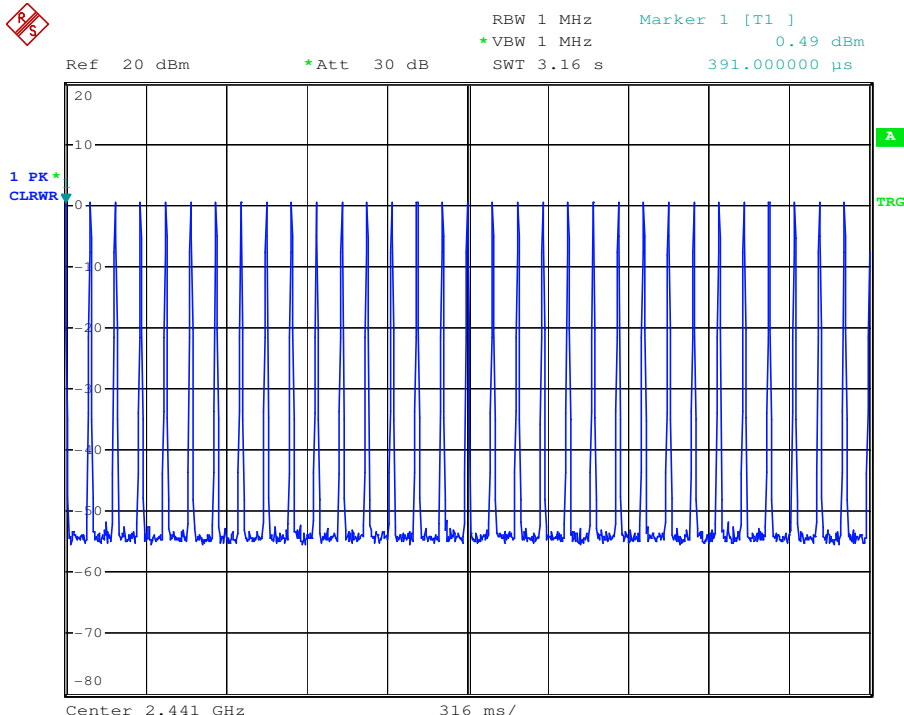
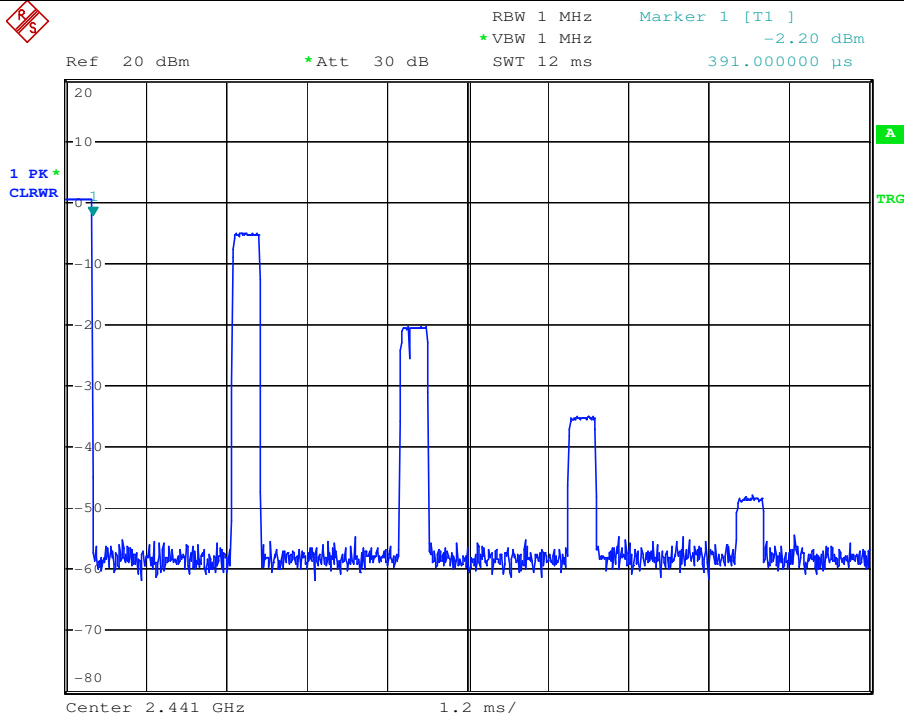

This document is issued by the Company subject to its General Conditions of Service printed overleaf, available on request or accessible at [www.sgs.com/terms\\_and\\_conditions.htm](http://www.sgs.com/terms_and_conditions.htm) and, for electronic format documents, subject to Terms and Conditions for Electronic Documents at [www.sgs.com/terms\\_e-document.htm](http://www.sgs.com/terms_e-document.htm). Attention is drawn to the limitation of liability, indemnification and jurisdiction issues defined therein. Any holder of this document is advised that information contained hereon reflects the Company's findings at the time of its intervention only and within the limits of Client's instructions, if any. The Company's sole responsibility is to its Client and this document does not exonerate parties to a transaction from exercising all their rights and obligations under the transaction documents. This document cannot be reproduced except in full, without prior written approval of the Company. Any unauthorized alteration, forgery or falsification of the content or appearance of this document is unlawful and offenders may be prosecuted to the fullest extent of the law. Unless otherwise stated the results shown in this test report refer only to the sample(s) tested and such sample(s) are retained for 90 days only

Test mode:	GFSK-DH3	Test channel:	Middle
------------	----------	---------------	--------



Ref 20 dBm      \*Att 30 dB      RBW 1 MHz      Marker 1 [T1 ]  
 \*VBW 1 MHz      0.46 dBm  
 SWT 12 ms      1.639000 ms

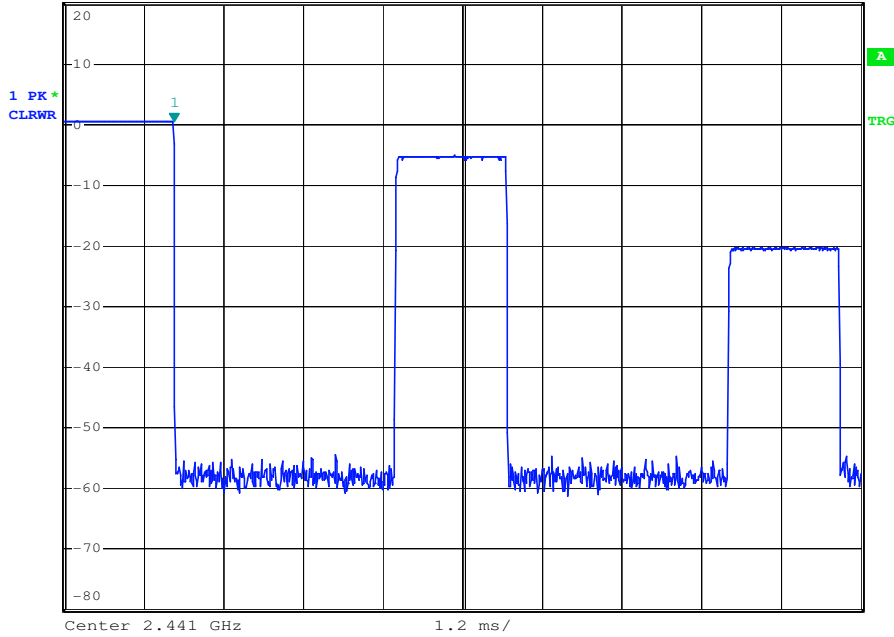

Ref 20 dBm      \*Att 30 dB      RBW 1 MHz      Marker 1 [T1 ]  
 \*VBW 1 MHz      -5.12 dBm  
 SWT 3.16 s      2.887000 ms

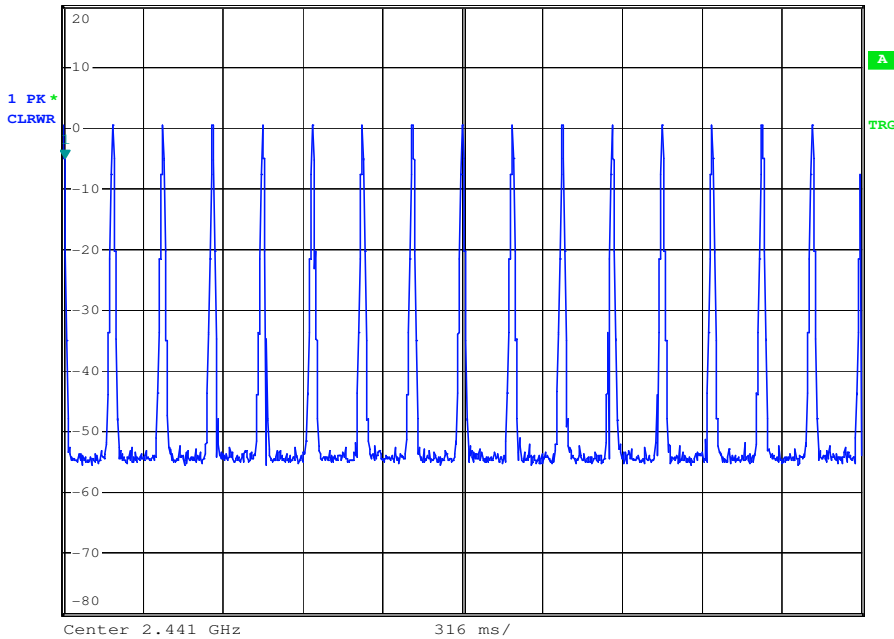

This document is issued by the Company subject to its General Conditions of Service printed overleaf, available on request or accessible at [www.sgs.com/terms\\_and\\_conditions.htm](http://www.sgs.com/terms_and_conditions.htm) and, for electronic format documents, subject to Terms and Conditions for Electronic Documents at [www.sgs.com/terms\\_e-document.htm](http://www.sgs.com/terms_e-document.htm). Attention is drawn to the limitation of liability, indemnification and jurisdiction issues defined therein. Any holder of this document is advised that information contained hereon reflects the Company's findings at the time of its intervention only and within the limits of Client's instructions, if any. The Company's sole responsibility is to its Client and this document does not exonerate parties to a transaction from exercising all their rights and obligations under the transaction documents. This document cannot be reproduced except in full, without prior written approval of the Company. Any unauthorized alteration, forgery or falsification of the content or appearance of this document is unlawful and offenders may be prosecuted to the fullest extent of the law. Unless otherwise stated the results shown in this test report refer only to the sample(s) tested and such sample(s) are retained for 90 days only

Test mode:	GFSK-DH5	Test channel:	Middle
------------	----------	---------------	--------



Ref 20 dBm      \*Att 30 dB      RBW 1 MHz      Marker 1 [T1]      0.45 dBm  
 \*VBW 1 MHz      2.887000 ms  
 SWT 12 ms

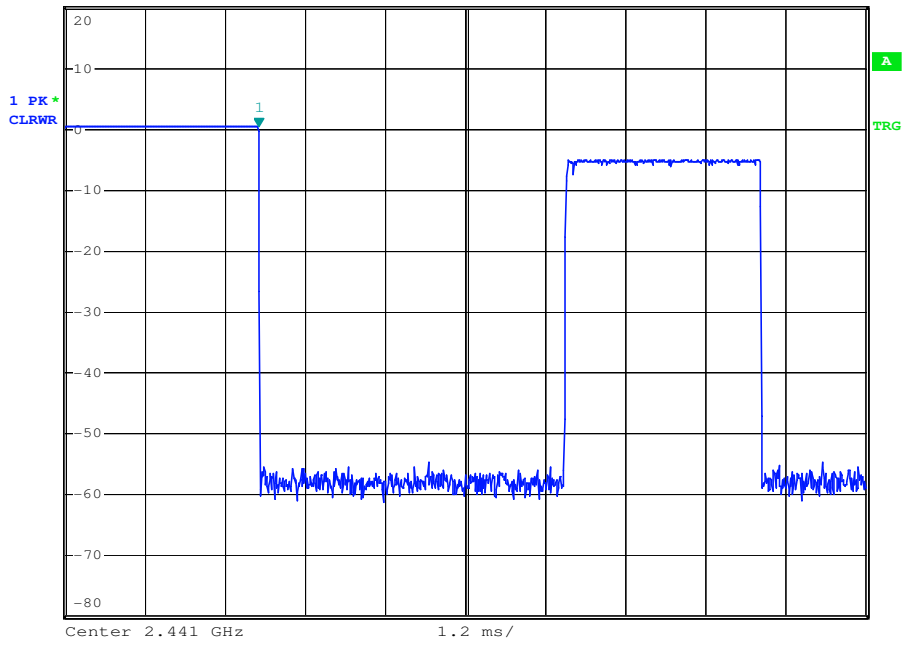

Ref 20 dBm      \*Att 30 dB      RBW 1 MHz      Marker 1 [T1]      -54.65 dBm  
 \*VBW 1 MHz      2.887000 ms  
 SWT 3.16 s

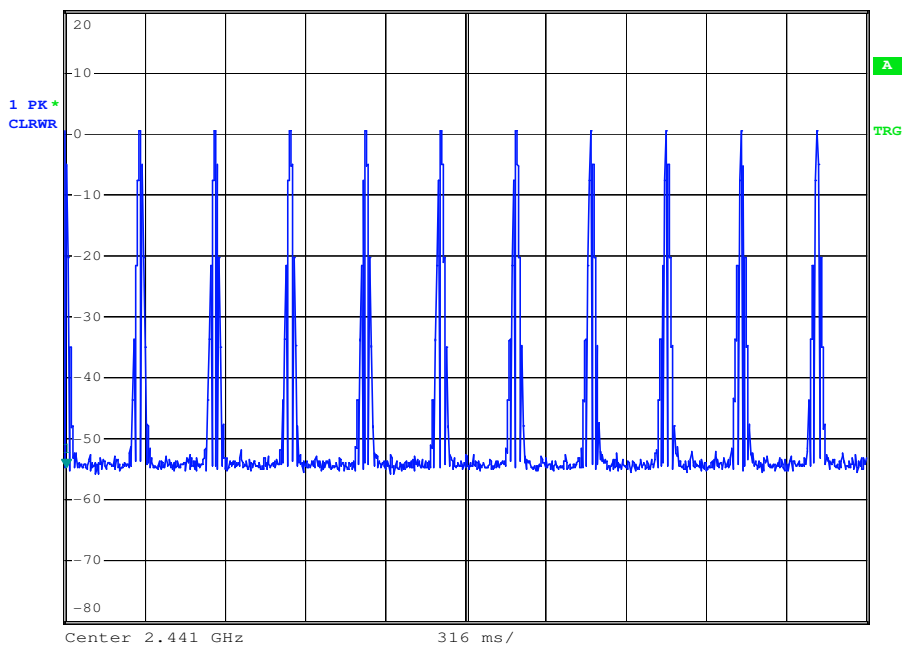

This document is issued by the Company subject to its General Conditions of Service printed overleaf, available on request or accessible at [www.sgs.com/terms\\_and\\_conditions.htm](http://www.sgs.com/terms_and_conditions.htm) and, for electronic format documents, subject to Terms and Conditions for Electronic Documents at [www.sgs.com/terms\\_e-document.htm](http://www.sgs.com/terms_e-document.htm). Attention is drawn to the limitation of liability, indemnification and jurisdiction issues defined therein. Any holder of this document is advised that information contained hereon reflects the Company's findings at the time of its intervention only and within the limits of Client's instructions, if any. The Company's sole responsibility is to its Client and this document does not exonerate parties to a transaction from exercising all their rights and obligations under the transaction documents. This document cannot be reproduced except in full, without prior written approval of the Company. Any unauthorized alteration, forgery or falsification of the content or appearance of this document is unlawful and offenders may be prosecuted to the fullest extent of the law. Unless otherwise stated the results shown in this test report refer only to the sample(s) tested and such sample(s) are retained for 90 days only



Test mode:	$\pi/4$ DQPSK -DH1	Test channel:	Middle
------------	--------------------	---------------	--------

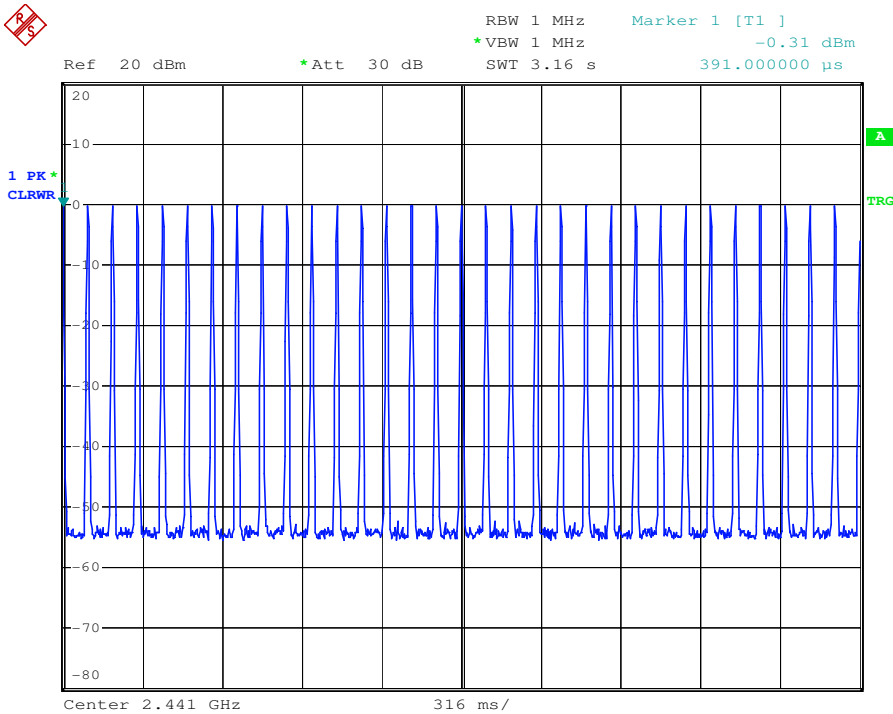
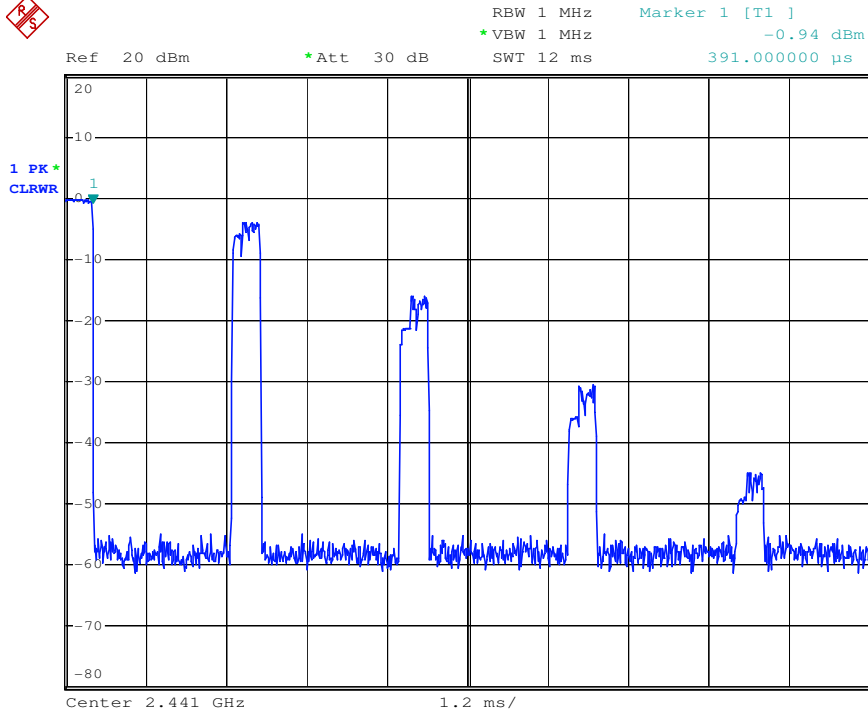

This document is issued by the Company subject to its General Conditions of Service printed overleaf, available on request or accessible at [www.sgs.com/terms\\_and\\_conditions.htm](http://www.sgs.com/terms_and_conditions.htm) and, for electronic format documents, subject to Terms and Conditions for Electronic Documents at [www.sgs.com/terms\\_e-document.htm](http://www.sgs.com/terms_e-document.htm). Attention is drawn to the limitation of liability, indemnification and jurisdiction issues defined therein. Any holder of this document is advised that information contained hereon reflects the Company's findings at the time of its intervention only and within the limits of Client's instructions, if any. The Company's sole responsibility is to its Client and this document does not exonerate parties to a transaction from exercising all their rights and obligations under the transaction documents. This document cannot be reproduced except in full, without prior written approval of the Company. Any unauthorized alteration, forgery or falsification of the content or appearance of this document is unlawful and offenders may be prosecuted to the fullest extent of the law. Unless otherwise stated the results shown in this test report refer only to the sample(s) tested and such sample(s) are retained for 90 days only

Test mode:	$\pi/4$ DQPSK -DH3	Test channel:	Middle
------------	--------------------	---------------	--------



Ref 20 dBm      \*Att 30 dB      RBW 1 MHz      Marker 1 [T1 ]  
 \*VBW 1 MHz      -0.95 dBm  
 SWT 12 ms      1.500000 ms

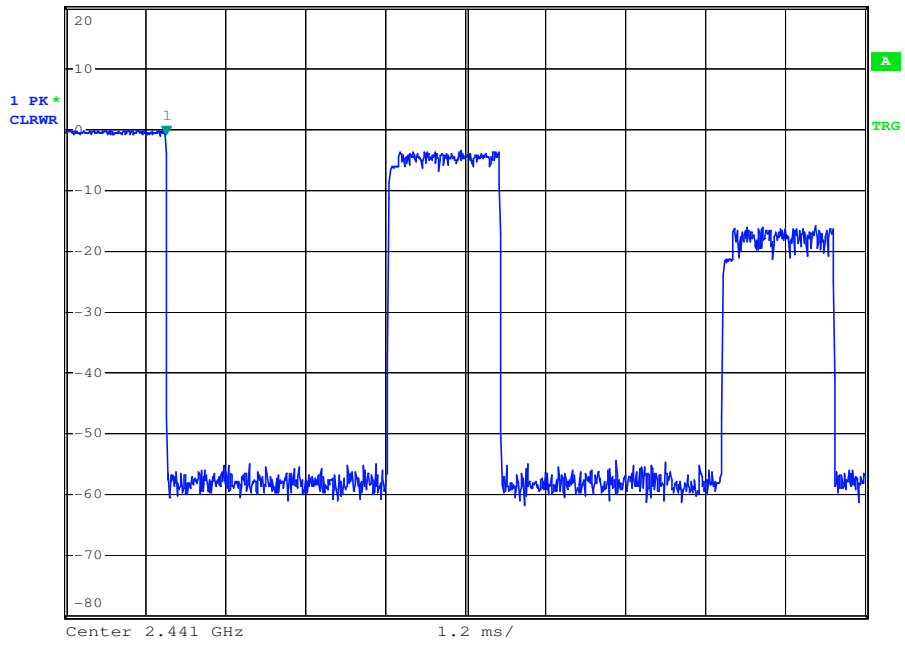

Ref 20 dBm      \*Att 30 dB      RBW 1 MHz      Marker 1 [T1 ]  
 \*VBW 1 MHz      -0.29 dBm  
 SWT 3.16 s      1.500000 ms

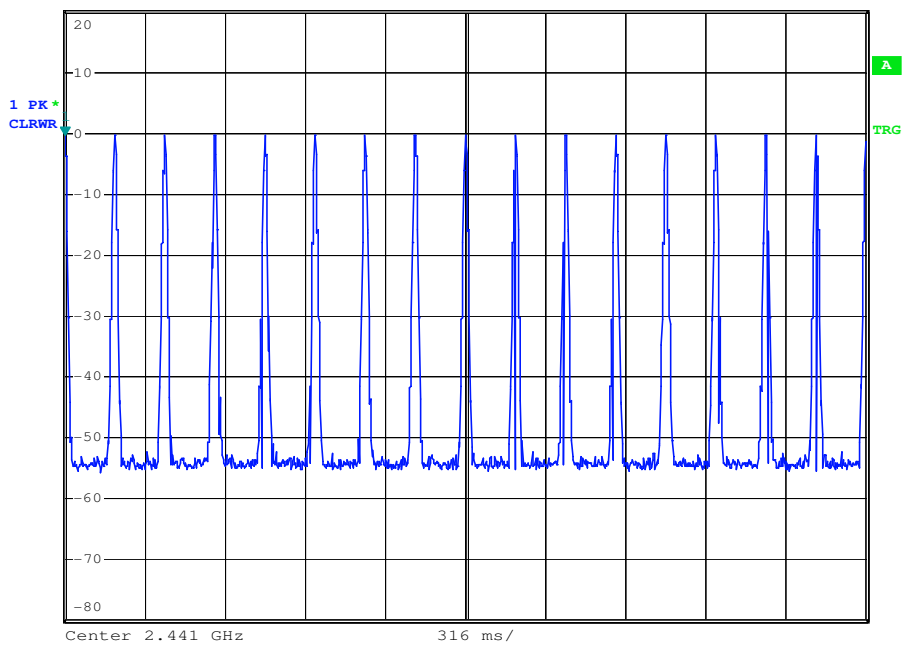

This document is issued by the Company subject to its General Conditions of Service printed overleaf, available on request or accessible at [www.sgs.com/terms\\_and\\_conditions.htm](http://www.sgs.com/terms_and_conditions.htm) and, for electronic format documents, subject to Terms and Conditions for Electronic Documents at [www.sgs.com/terms\\_e-document.htm](http://www.sgs.com/terms_e-document.htm). Attention is drawn to the limitation of liability, indemnification and jurisdiction issues defined therein. Any holder of this document is advised that information contained hereon reflects the Company's findings at the time of its intervention only and within the limits of Client's instructions, if any. The Company's sole responsibility is to its Client and this document does not exonerate parties to a transaction from exercising all their rights and obligations under the transaction documents. This document cannot be reproduced except in full, without prior written approval of the Company. Any unauthorized alteration, forgery or falsification of the content or appearance of this document is unlawful and offenders may be prosecuted to the fullest extent of the law. Unless otherwise stated the results shown in this test report refer only to the sample(s) tested and such sample(s) are retained for 90 days only

Test mode:	$\pi/4$ DQPSK -DH5	Test channel:	Middle
------------	--------------------	---------------	--------



Ref 20 dBm      \*Att 30 dB      RBW 1 MHz      Marker 1 [T1 ]  
 \*VBW 1 MHz      -0.93 dBm  
 SWT 12 ms      1.548000 ms

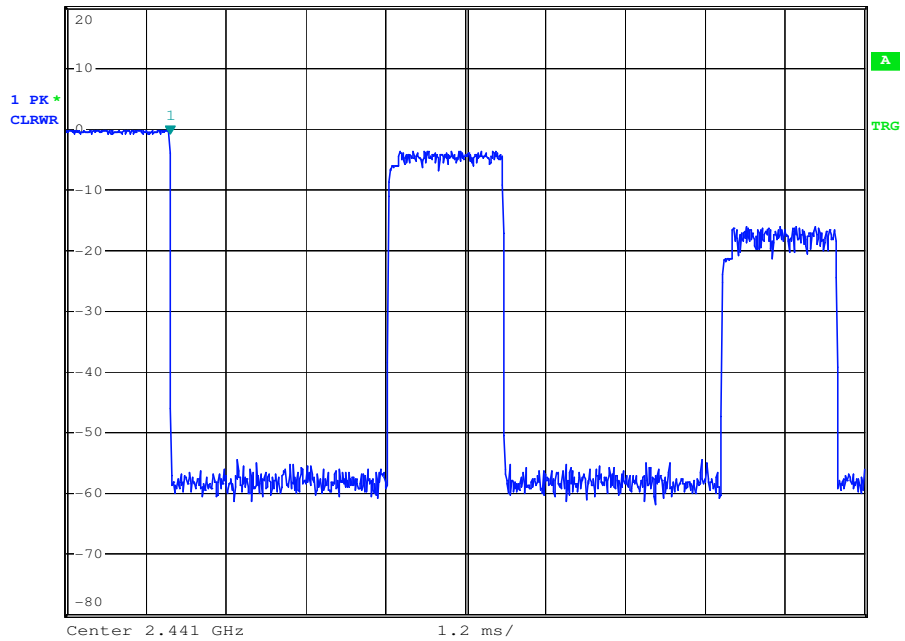

Ref 20 dBm      \*Att 30 dB      RBW 1 MHz      Marker 1 [T1 ]  
 \*VBW 1 MHz      -0.30 dBm  
 SWT 3.16 s      1.500000 ms

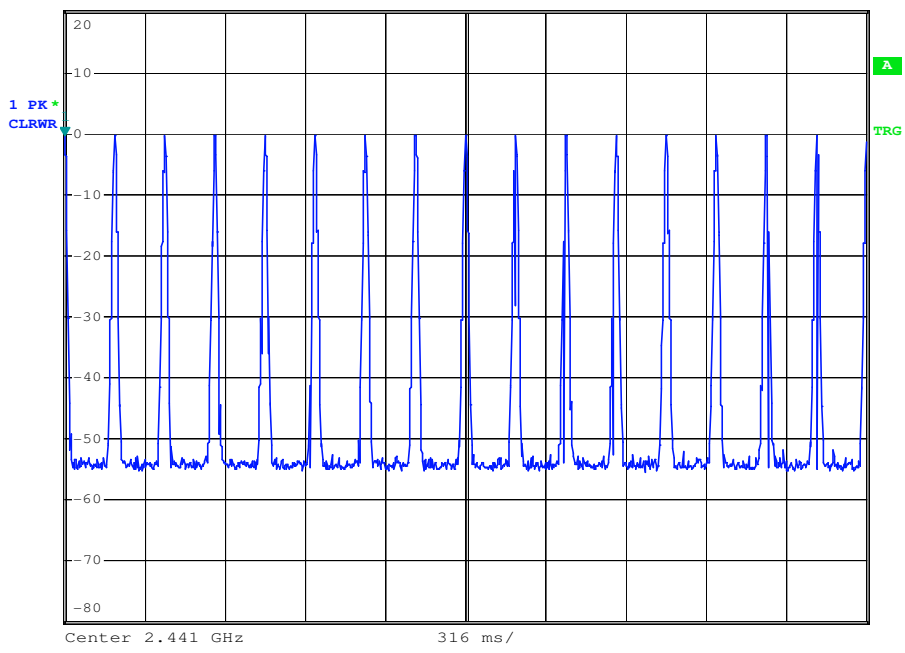

This document is issued by the Company subject to its General Conditions of Service printed overleaf, available on request or accessible at [www.sgs.com/terms\\_and\\_conditions.htm](http://www.sgs.com/terms_and_conditions.htm) and, for electronic format documents, subject to Terms and Conditions for Electronic Documents at [www.sgs.com/terms\\_e-document.htm](http://www.sgs.com/terms_e-document.htm). Attention is drawn to the limitation of liability, indemnification and jurisdiction issues defined therein. Any holder of this document is advised that information contained hereon reflects the Company's findings at the time of its intervention only and within the limits of Client's instructions, if any. The Company's sole responsibility is to its Client and this document does not exonerate parties to a transaction from exercising all their rights and obligations under the transaction documents. This document cannot be reproduced except in full, without prior written approval of the Company. Any unauthorized alteration, forgery or falsification of the content or appearance of this document is unlawful and offenders may be prosecuted to the fullest extent of the law. Unless otherwise stated the results shown in this test report refer only to the sample(s) tested and such sample(s) are retained for 90 days only



Test mode:	8DPSK -DH1	Test channel:	Middle
------------	------------	---------------	--------

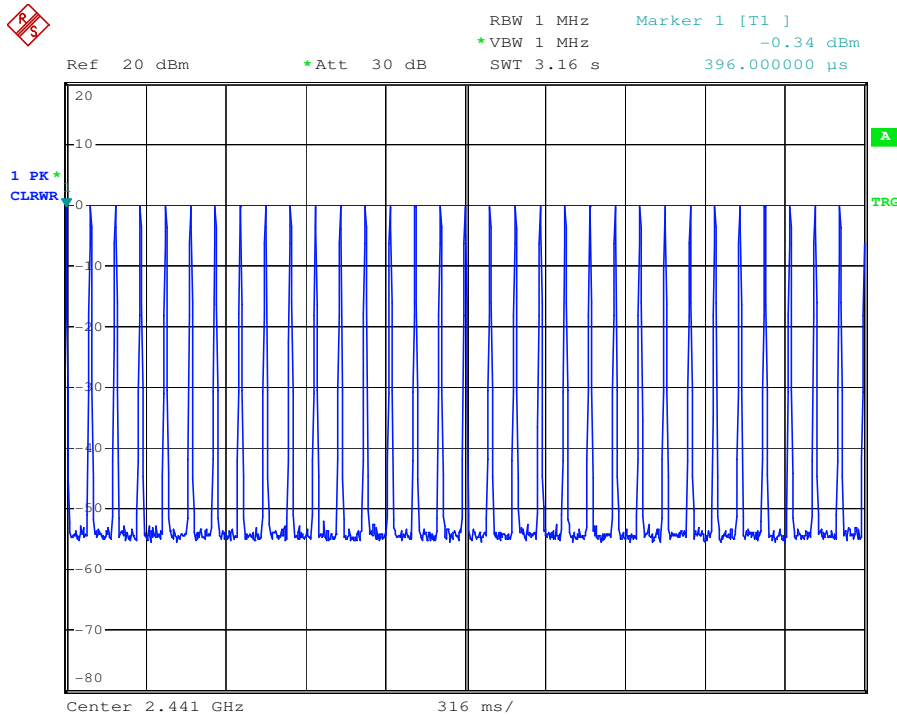
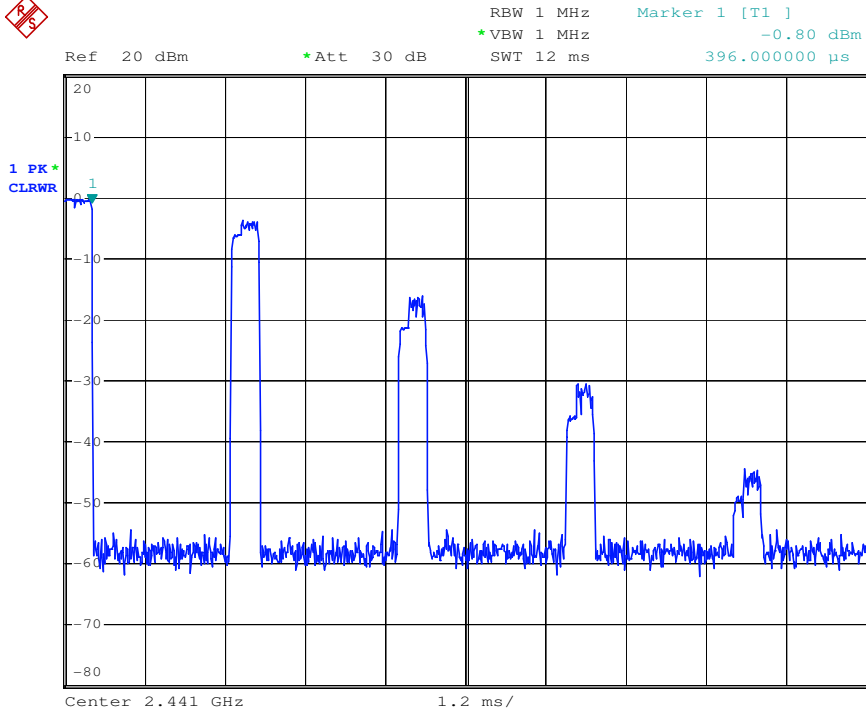

This document is issued by the Company subject to its General Conditions of Service printed overleaf, available on request or accessible at [www.sgs.com/terms\\_and\\_conditions.htm](http://www.sgs.com/terms_and_conditions.htm) and, for electronic format documents, subject to Terms and Conditions for Electronic Documents at [www.sgs.com/terms\\_e-document.htm](http://www.sgs.com/terms_e-document.htm). Attention is drawn to the limitation of liability, indemnification and jurisdiction issues defined therein. Any holder of this document is advised that information contained hereon reflects the Company's findings at the time of its intervention only and within the limits of Client's instructions, if any. The Company's sole responsibility is to its Client and this document does not exonerate parties to a transaction from exercising all their rights and obligations under the transaction documents. This document cannot be reproduced except in full, without prior written approval of the Company. Any unauthorized alteration, forgery or falsification of the content or appearance of this document is unlawful and offenders may be prosecuted to the fullest extent of the law. Unless otherwise stated the results shown in this test report refer only to the sample(s) tested and such sample(s) are retained for 90 days only

Test mode:	8DPSK -DH3	Test channel:	Middle
------------	------------	---------------	--------



Ref 20 dBm      \*Att 30 dB      RBW 1 MHz      Marker 1 [T1]      -0.75 dBm  
 \*VBW 1 MHz      1.644000 ms  
 SWT 12 ms

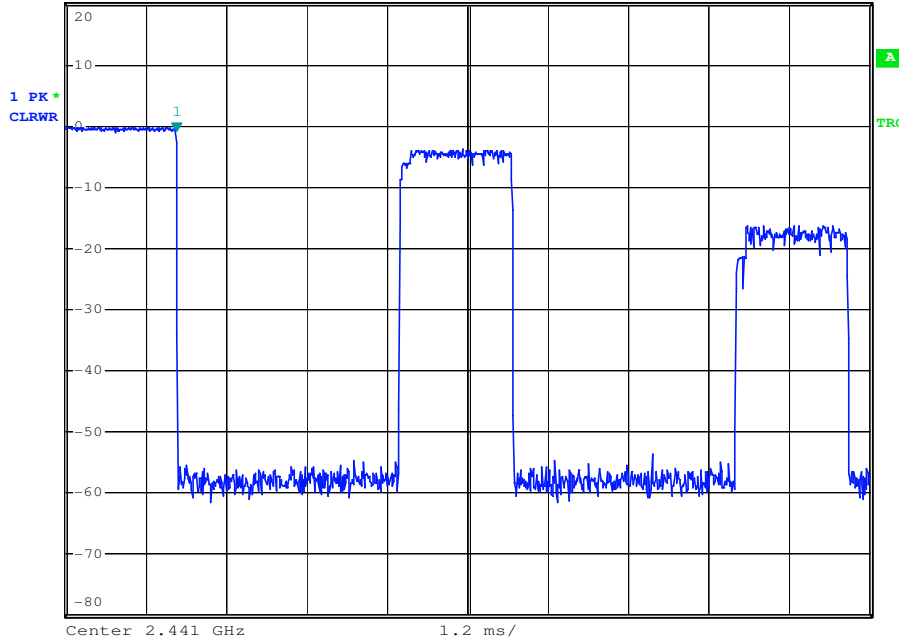

Ref 20 dBm      \*Att 30 dB      RBW 1 MHz      Marker 1 [T1]      -0.34 dBm  
 \*VBW 1 MHz      396.000000 μs  
 SWT 3.16 s

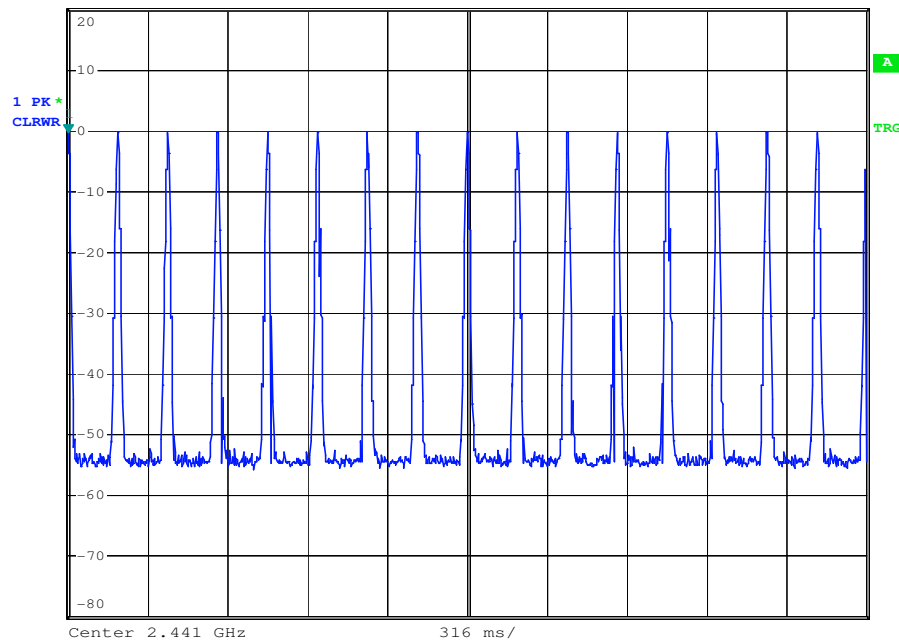

This document is issued by the Company subject to its General Conditions of Service printed overleaf, available on request or accessible at [www.sgs.com/terms\\_and\\_conditions.htm](http://www.sgs.com/terms_and_conditions.htm) and, for electronic format documents, subject to Terms and Conditions for Electronic Documents at [www.sgs.com/terms\\_e-document.htm](http://www.sgs.com/terms_e-document.htm). Attention is drawn to the limitation of liability, indemnification and jurisdiction issues defined therein. Any holder of this document is advised that information contained hereon reflects the Company's findings at the time of its intervention only and within the limits of Client's instructions, if any. The Company's sole responsibility is to its Client and this document does not exonerate parties to a transaction from exercising all their rights and obligations under the transaction documents. This document cannot be reproduced except in full, without prior written approval of the Company. Any unauthorized alteration, forgery or falsification of the content or appearance of this document is unlawful and offenders may be prosecuted to the fullest extent of the law. Unless otherwise stated the results shown in this test report refer only to the sample(s) tested and such sample(s) are retained for 90 days only

Test mode:	8DPSK -DH5	Test channel:	Middle
------------	------------	---------------	--------



Ref 20 dBm      \*Att 30 dB      RBW 1 MHz      Marker 1 [T1 ]  
 \*VBW 1 MHz      -0.66 dBm  
 SWT 12 ms      2.892000 ms

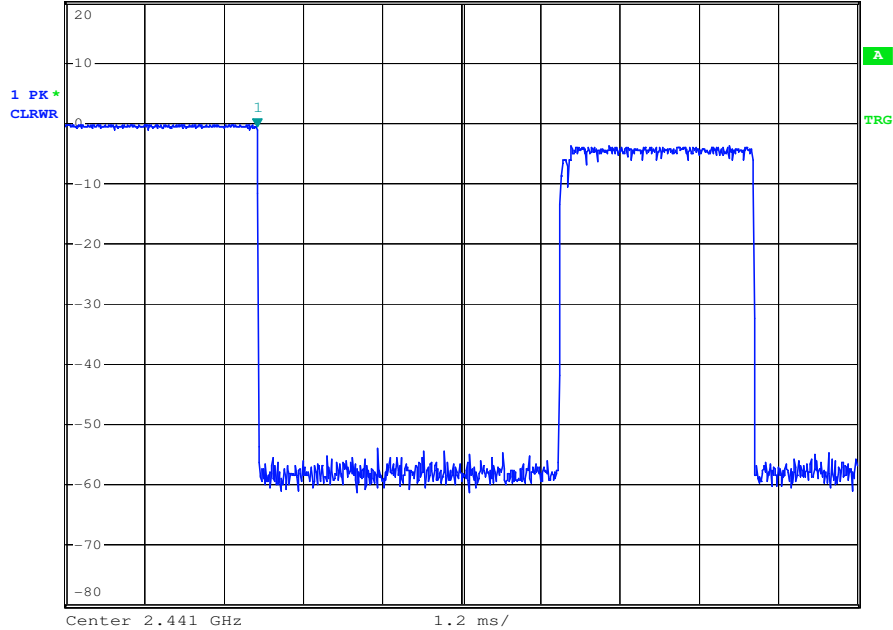

Ref 20 dBm      \*Att 30 dB      RBW 1 MHz      Marker 1 [T1 ]  
 \*VBW 1 MHz      -53.85 dBm  
 SWT 3.16 s      2.892000 ms

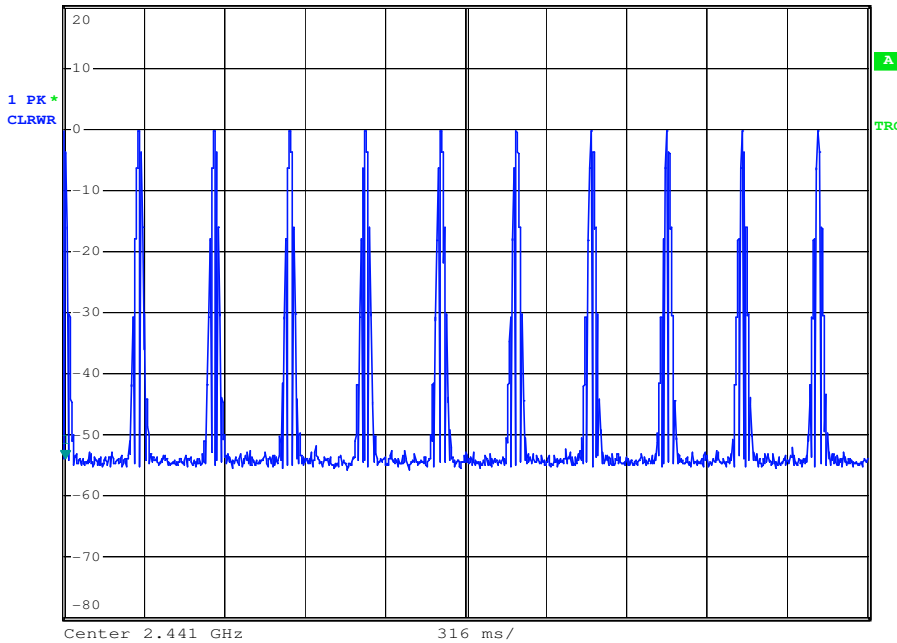

This document is issued by the Company subject to its General Conditions of Service printed overleaf, available on request or accessible at [www.sgs.com/terms\\_and\\_conditions.htm](http://www.sgs.com/terms_and_conditions.htm) and, for electronic format documents, subject to Terms and Conditions for Electronic Documents at [www.sgs.com/terms\\_e-document.htm](http://www.sgs.com/terms_e-document.htm). Attention is drawn to the limitation of liability, indemnification and jurisdiction issues defined therein. Any holder of this document is advised that information contained hereon reflects the Company's findings at the time of its intervention only and within the limits of Client's instructions, if any. The Company's sole responsibility is to its Client and this document does not exonerate parties to a transaction from exercising all their rights and obligations under the transaction documents. This document cannot be reproduced except in full, without prior written approval of the Company. Any unauthorized alteration, forgery or falsification of the content or appearance of this document is unlawful and offenders may be prosecuted to the fullest extent of the law. Unless otherwise stated the results shown in this test report refer only to the sample(s) tested and such sample(s) are retained for 90 days only

## 7.10 Conducted Spurious Emissions and Band-edge

**Limit:** (d) In any 100 kHz bandwidth outside the frequency band in which the spread spectrum or digitally modulated intentional radiator is operating. The radio frequency power that is produced by the intentional radiator shall be at least 20 dB below that in the 100 kHz bandwidth within the band that contains the highest level of the desired power. Based on either an RF conducted or a radiated measurement. Provided the transmitter demonstrates compliance with the peak conducted power limits.

**Test Configuration:**

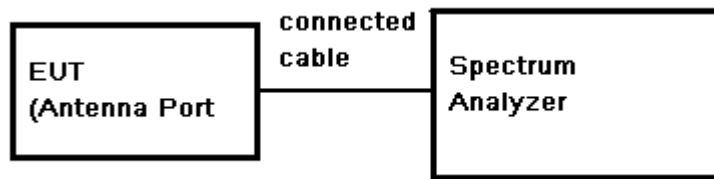

**Test Procedure:**

1. Remove the antenna from the EUT and then connect a low RF cable from the antenna port to the spectrum.
2. Set the spectrum analyzer: RBW = 100KHz. VBW >= RBW. Sweep = auto; Detector Function = Peak (Max. hold).

**Test Result:** Pass

**7.10.1 Conducted spurious emission**

Test plot as follows:

Test mode:	GFSK	Test channel:	Lowest
------------	------	---------------	--------

30MHz-3GHz:

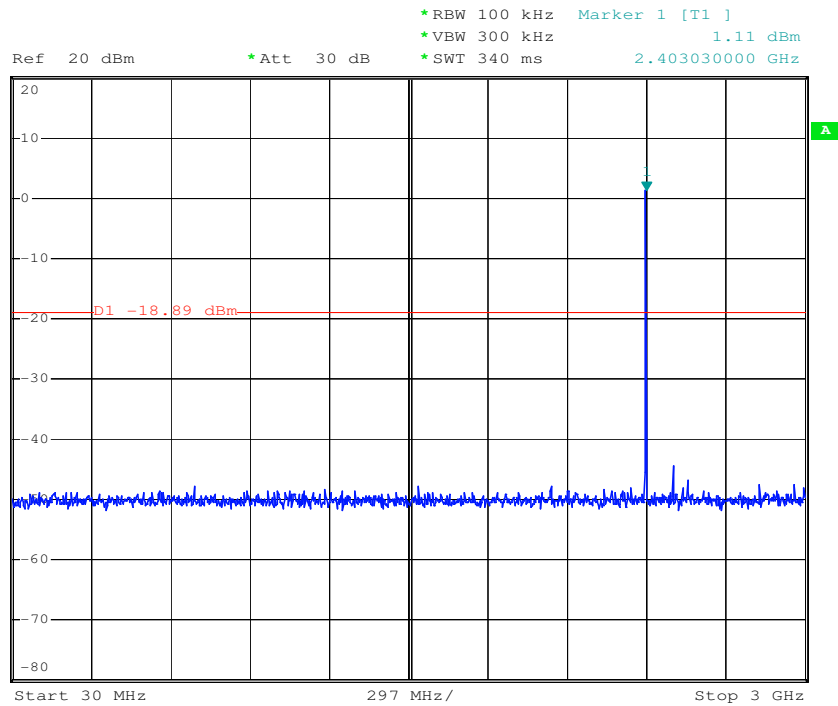

3GHz-13.6GHz:

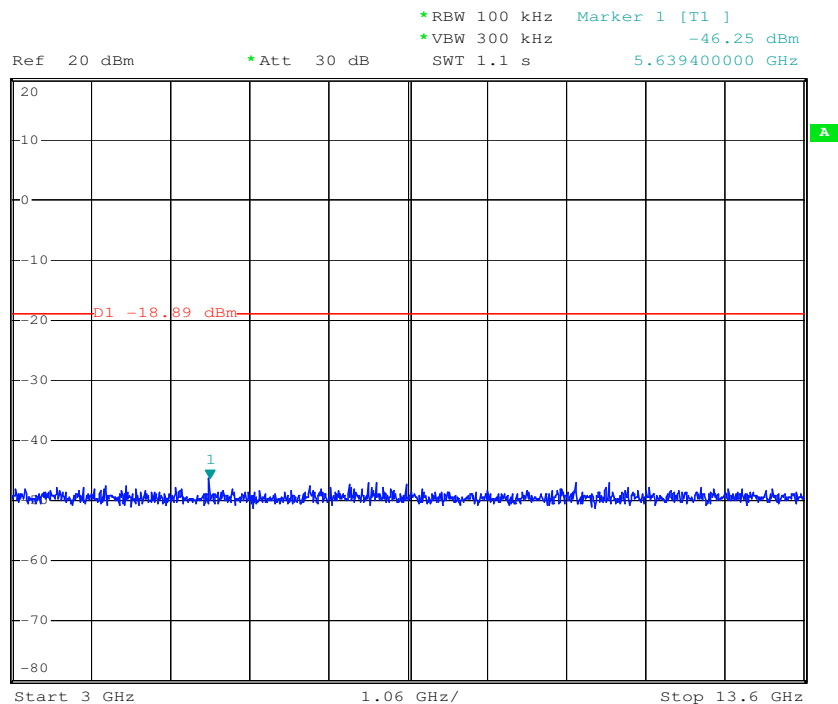

This document is issued by the Company subject to its General Conditions of Service printed overleaf, available on request or accessible at [www.sgs.com/terms\\_and\\_conditions.htm](http://www.sgs.com/terms_and_conditions.htm) and, for electronic format documents, subject to Terms and Conditions for Electronic Documents at [www.sgs.com/terms\\_e-document.htm](http://www.sgs.com/terms_e-document.htm). Attention is drawn to the limitation of liability, indemnification and jurisdiction issues defined therein. Any holder of this document is advised that information contained hereon reflects the Company's findings at the time of its intervention only and within the limits of Client's instructions, if any. The Company's sole responsibility is to its Client and this document does not exonerate parties to a transaction from exercising all their rights and obligations under the transaction documents. This document cannot be reproduced except in full, without prior written approval of the Company. Any unauthorized alteration, forgery or falsification of the content or appearance of this document is unlawful and offenders may be prosecuted to the fullest extent of the law. Unless otherwise stated the results shown in this test report refer only to the sample(s) tested and such sample(s) are retained for 90 days only



13.6GHz-25GHz:

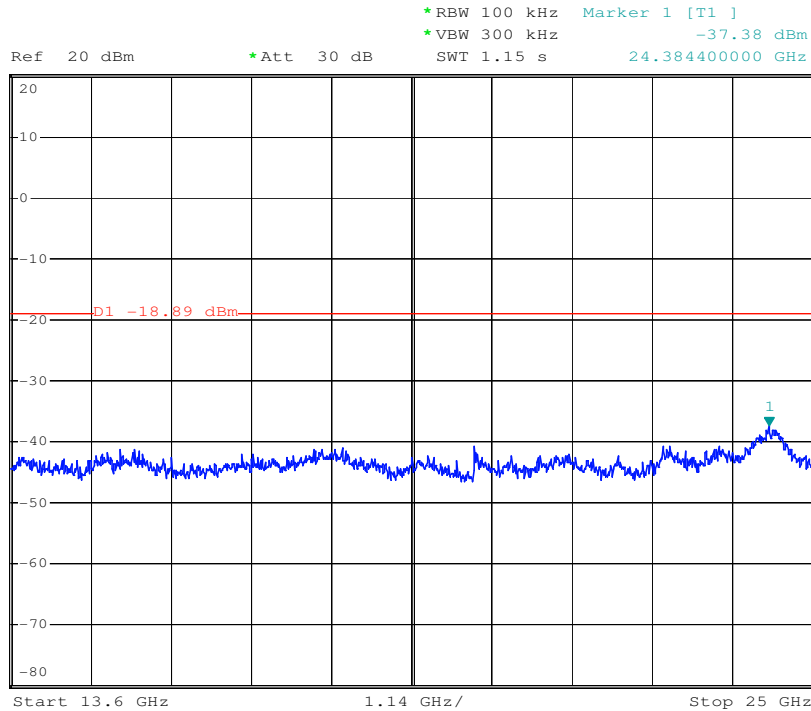

Test mode:	GFSK	Test channel:	Middle
------------	------	---------------	--------

30MHz-3GHz:

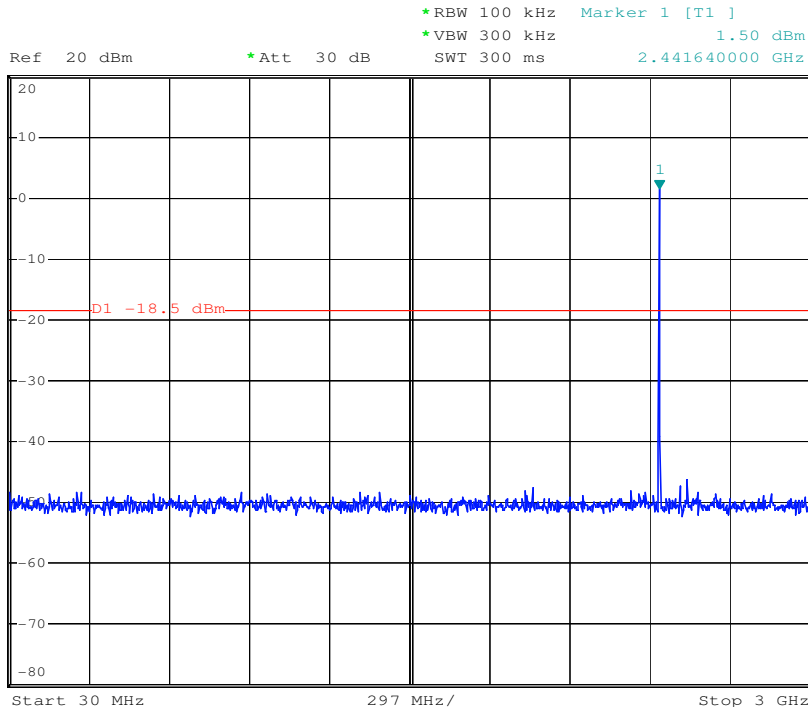

3GHz-13.6GHz:

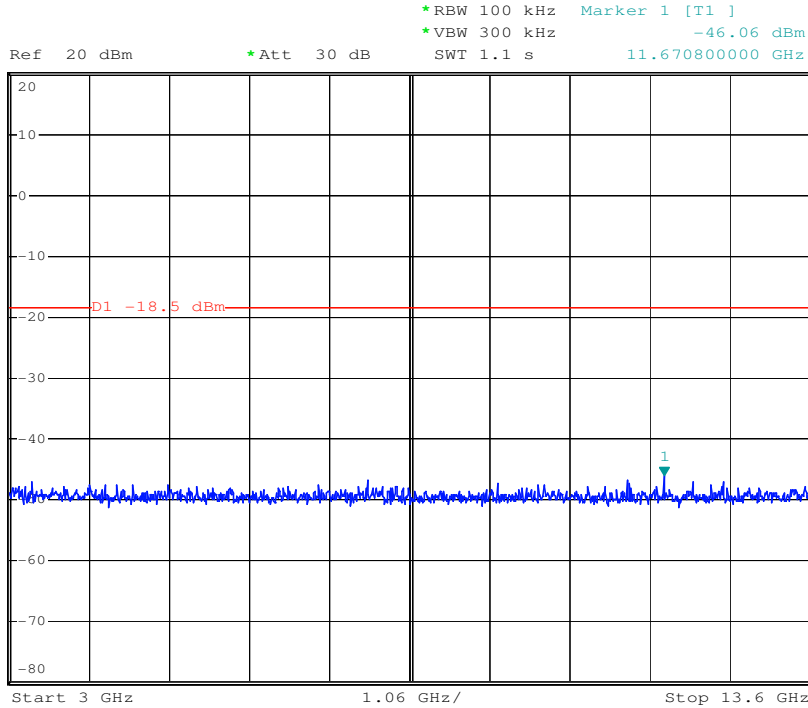

13.6GHz-25GHz:

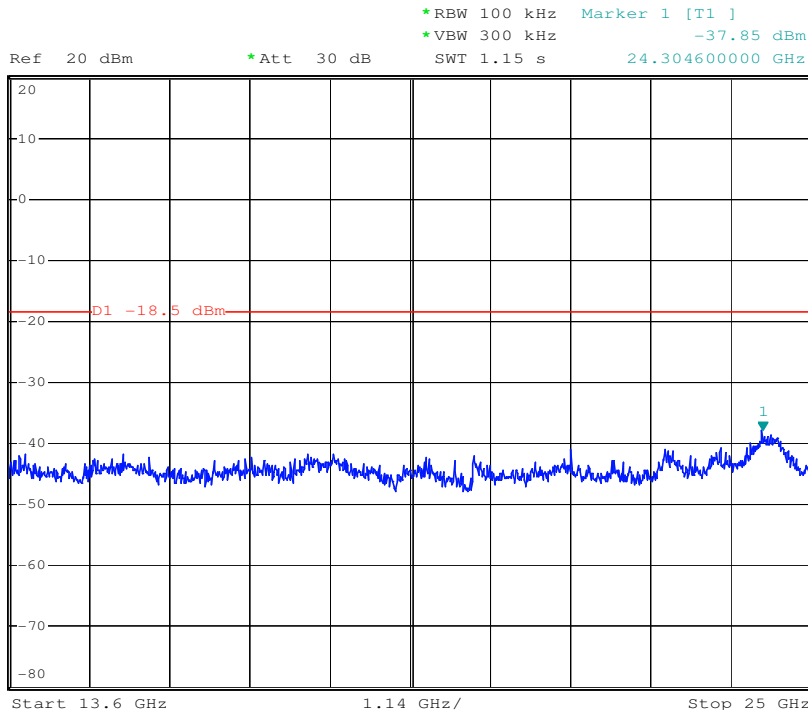

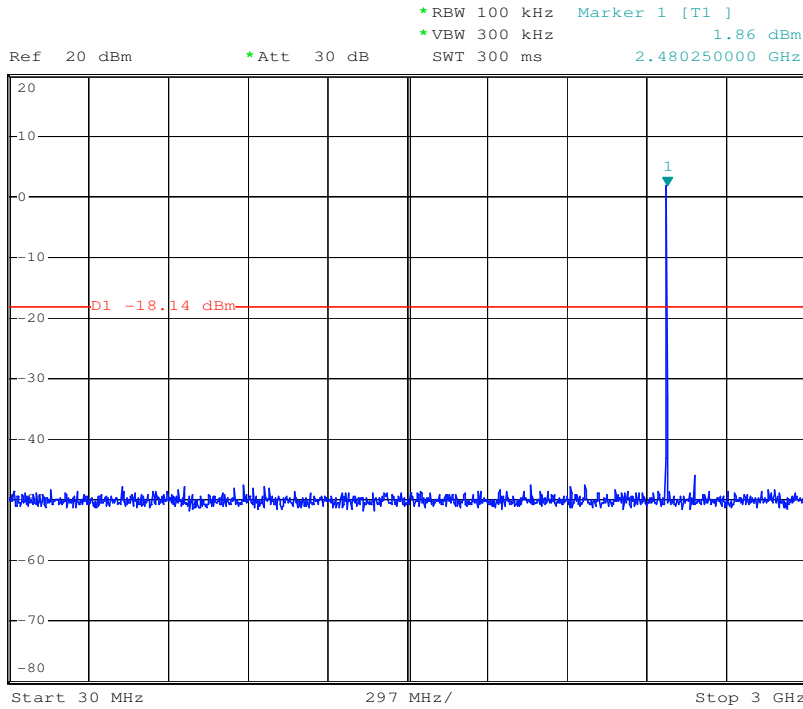

Test mode:	GFSK	Test channel:	Highest
------------	------	---------------	---------

30MHz-3GHz:

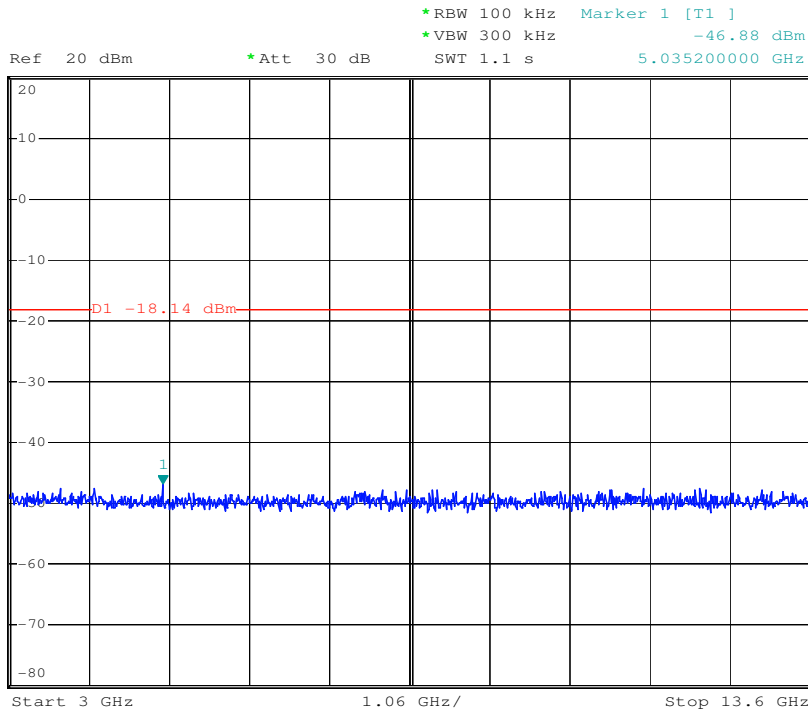

3GHz-13.6GHz:



13.6GHz-25GHz: 

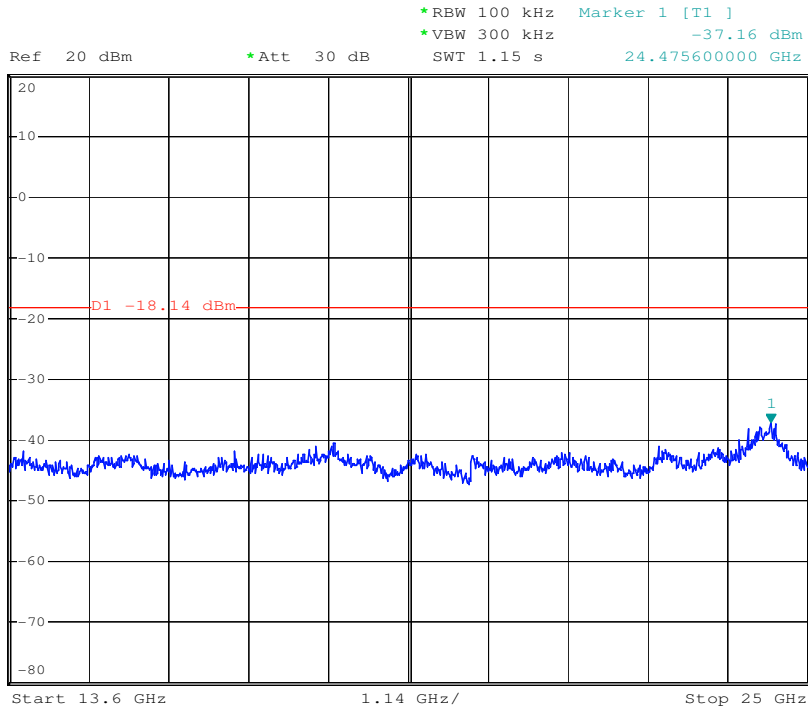

Test mode:	$\pi/4$ DQPSK	Test channel:	Lowest
------------	---------------	---------------	--------

30MHz-3GHz: 

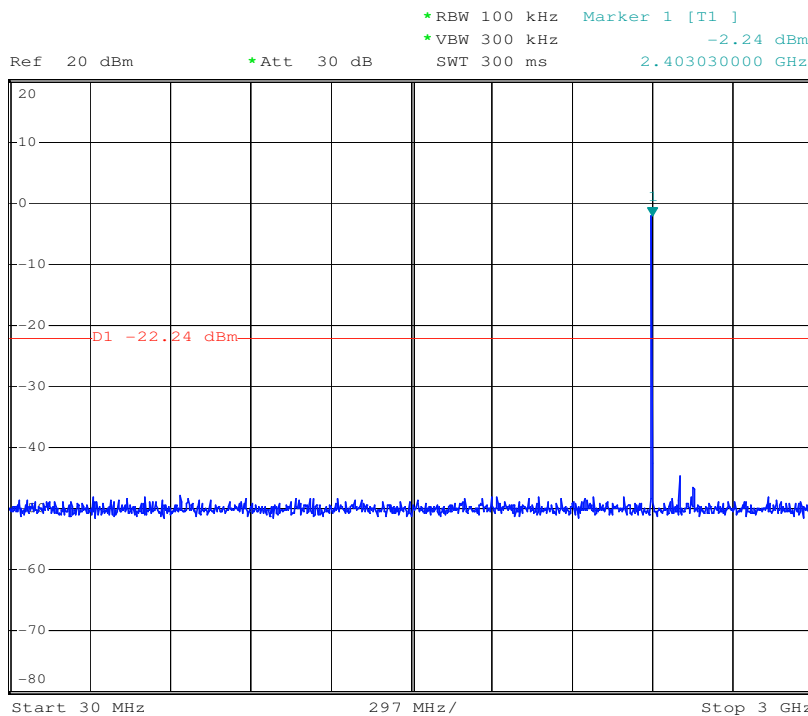

This document is issued by the Company subject to its General Conditions of Service printed overleaf, available on request or accessible at [www.sgs.com/terms\\_and\\_conditions.htm](http://www.sgs.com/terms_and_conditions.htm) and, for electronic format documents, subject to Terms and Conditions for Electronic Documents at [www.sgs.com/terms\\_e-document.htm](http://www.sgs.com/terms_e-document.htm). Attention is drawn to the limitation of liability, indemnification and jurisdiction issues defined therein. Any holder of this document is advised that information contained hereon reflects the Company's findings at the time of its intervention only and within the limits of Client's instructions, if any. The Company's sole responsibility is to its Client and this document does not exonerate parties to a transaction from exercising all their rights and obligations under the transaction documents. This document cannot be reproduced except in full, without prior written approval of the Company. Any unauthorized alteration, forgery or falsification of the content or appearance of this document is unlawful and offenders may be prosecuted to the fullest extent of the law. Unless otherwise stated the results shown in this test report refer only to the sample(s) tested and such sample(s) are retained for 90 days only

3GHz-13.6GHz:

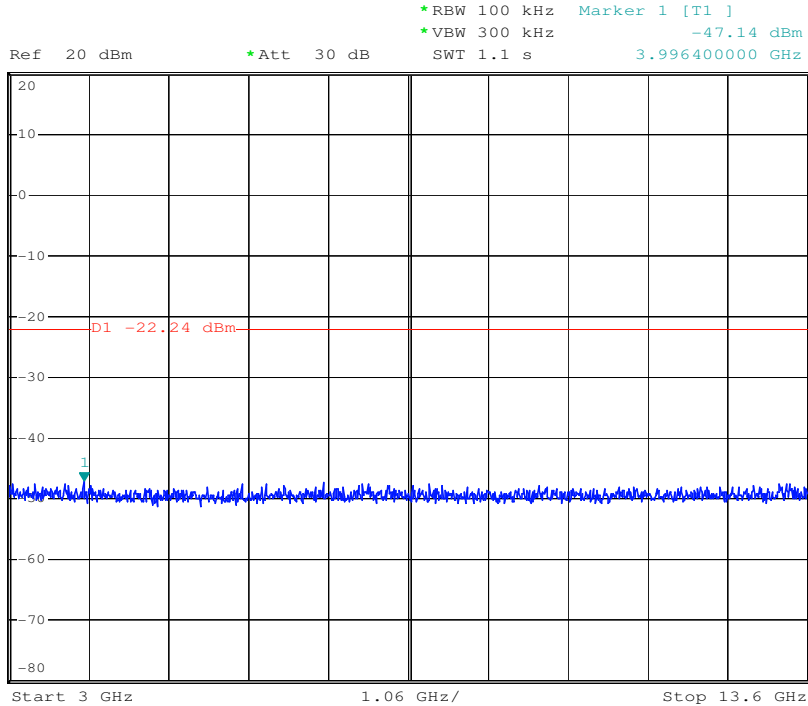

13.6GHz-25GHz:

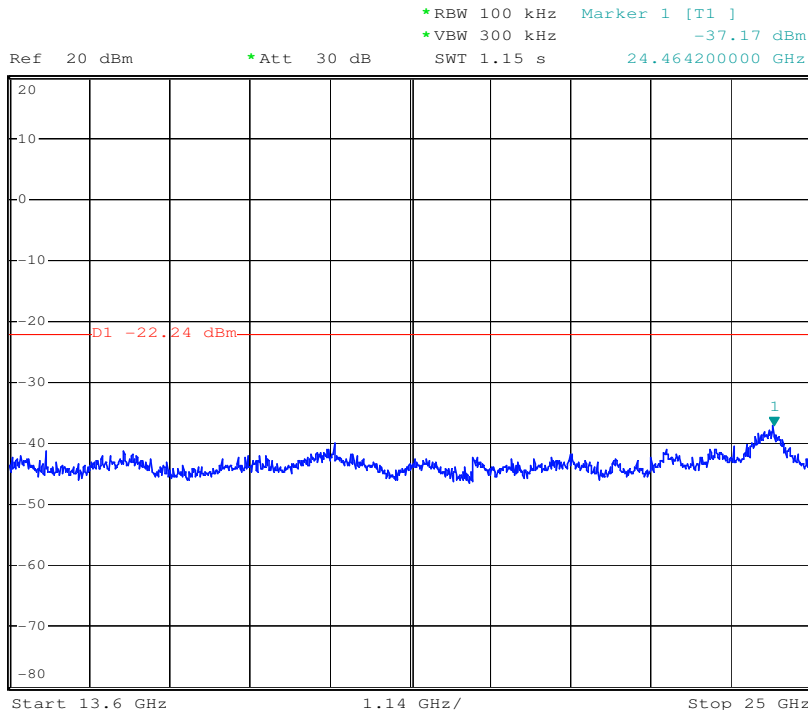

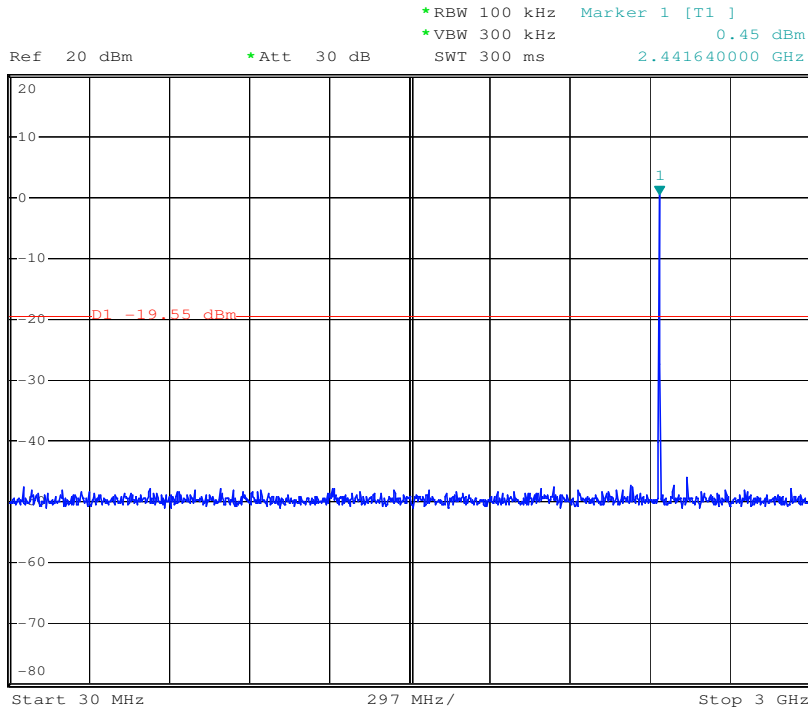

Test mode:	$\pi/4$ DQPSK	Test channel:	Middle
------------	---------------	---------------	--------

30MHz-3GHz:

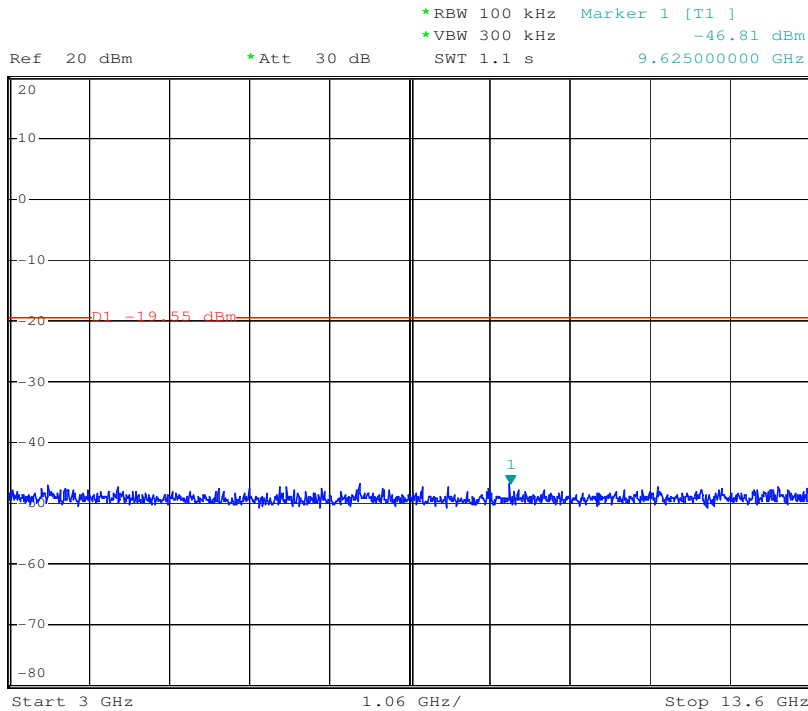

3GHz-13.6GHz:



13.6GHz-25GHz: 

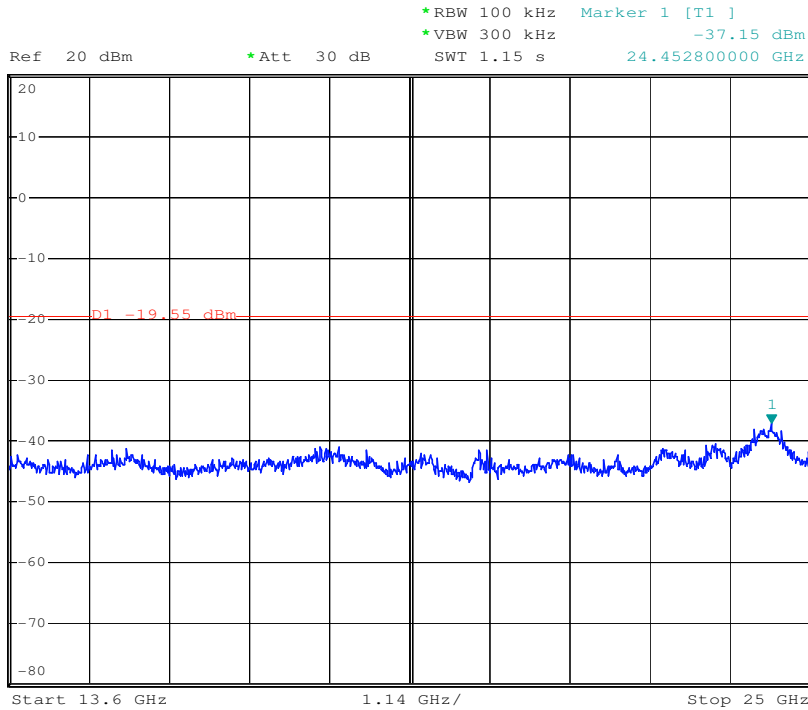

Test mode:	$\pi/4$ DQPSK	Test channel:	Highest
------------	---------------	---------------	---------

30MHz-3GHz: 

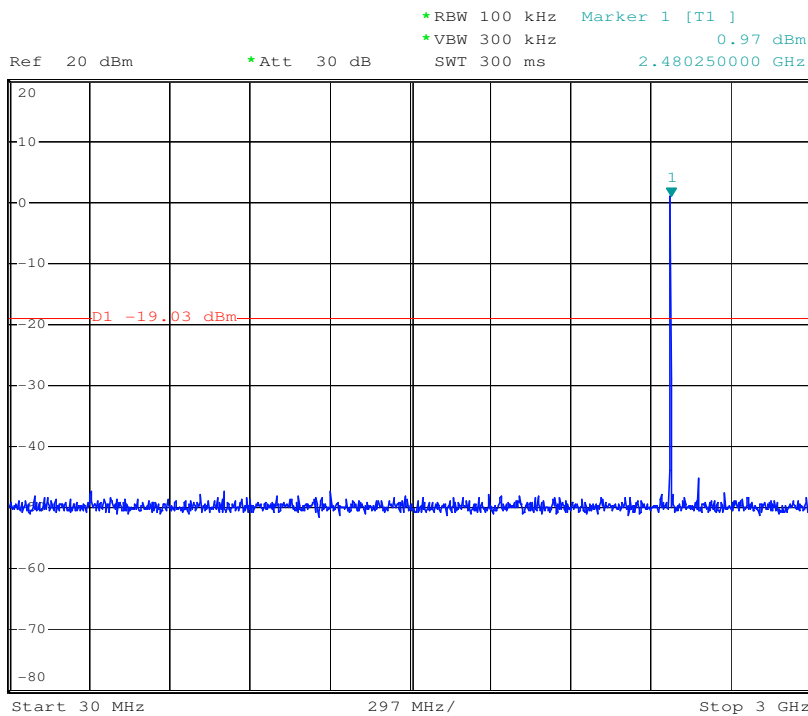

This document is issued by the Company subject to its General Conditions of Service printed overleaf, available on request or accessible at [www.sgs.com/terms\\_and\\_conditions.htm](http://www.sgs.com/terms_and_conditions.htm) and, for electronic format documents, subject to Terms and Conditions for Electronic Documents at [www.sgs.com/terms\\_e-document.htm](http://www.sgs.com/terms_e-document.htm). Attention is drawn to the limitation of liability, indemnification and jurisdiction issues defined therein. Any holder of this document is advised that information contained hereon reflects the Company's findings at the time of its intervention only and within the limits of Client's instructions, if any. The Company's sole responsibility is to its Client and this document does not exonerate parties to a transaction from exercising all their rights and obligations under the transaction documents. This document cannot be reproduced except in full, without prior written approval of the Company. Any unauthorized alteration, forgery or falsification of the content or appearance of this document is unlawful and offenders may be prosecuted to the fullest extent of the law. Unless otherwise stated the results shown in this test report refer only to the sample(s) tested and such sample(s) are retained for 90 days only

3GHz-13.6GHz:

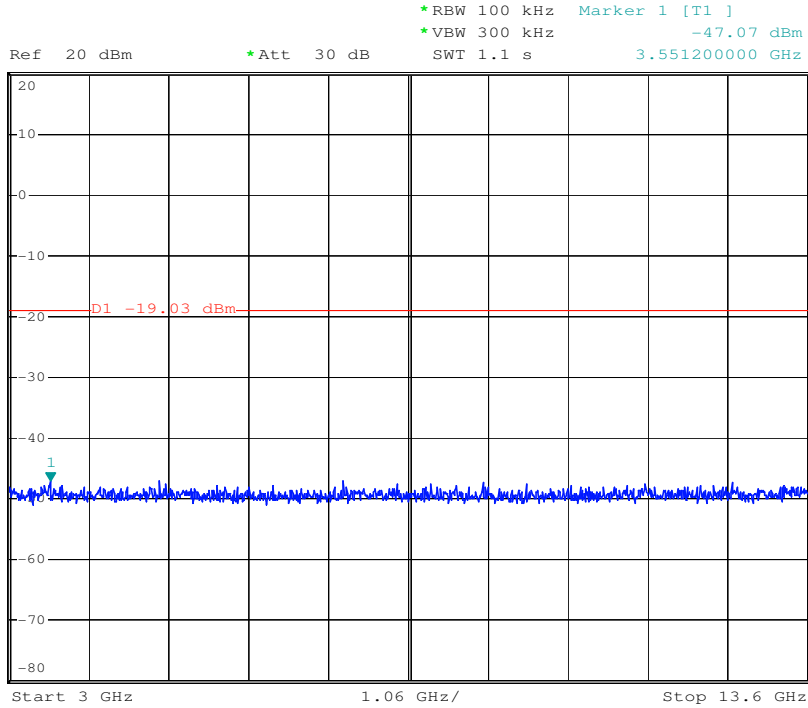

13.6GHz-25GHz:

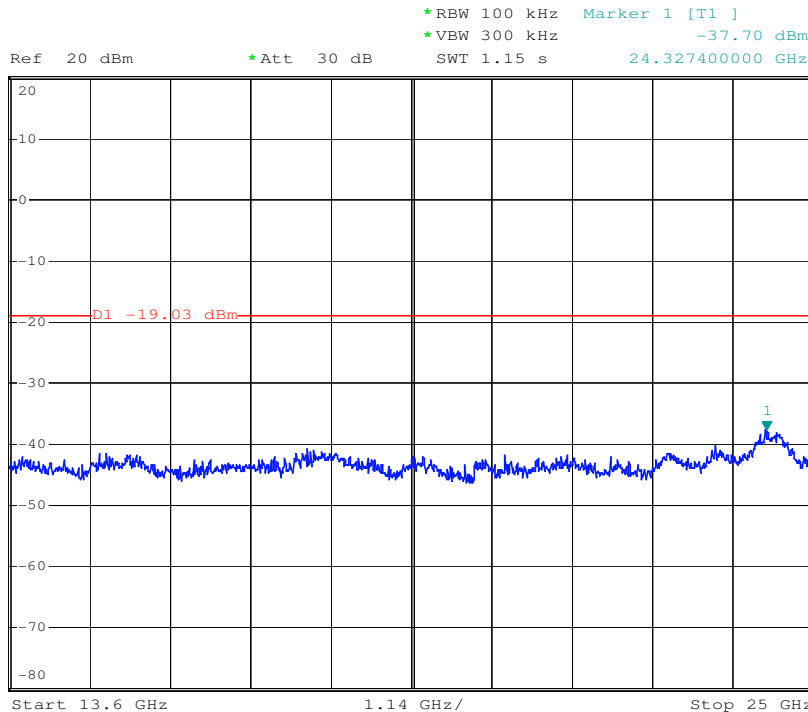



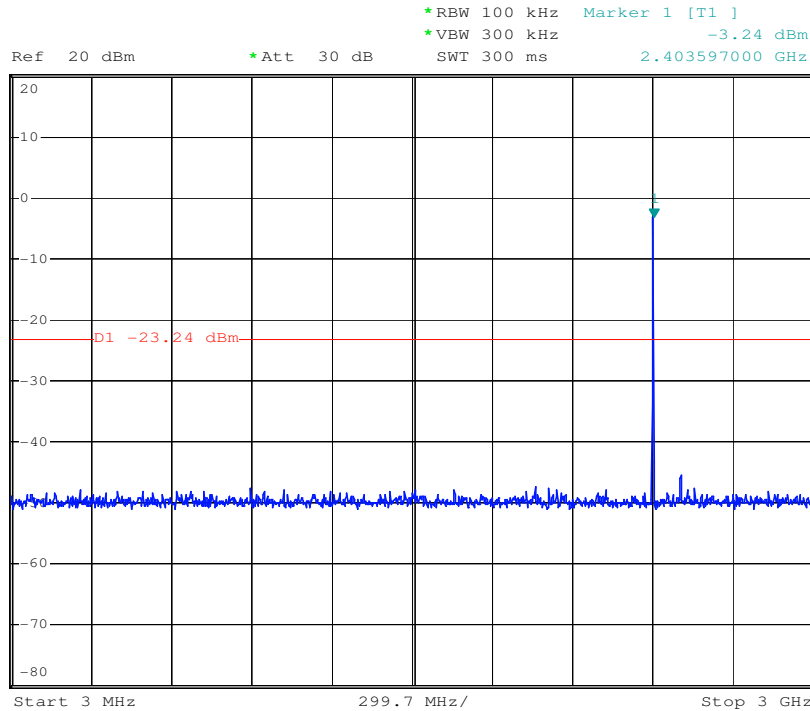

Test mode:	8DPSK	Test channel:	Lowest
------------	-------	---------------	--------

30MHz-3GHz:

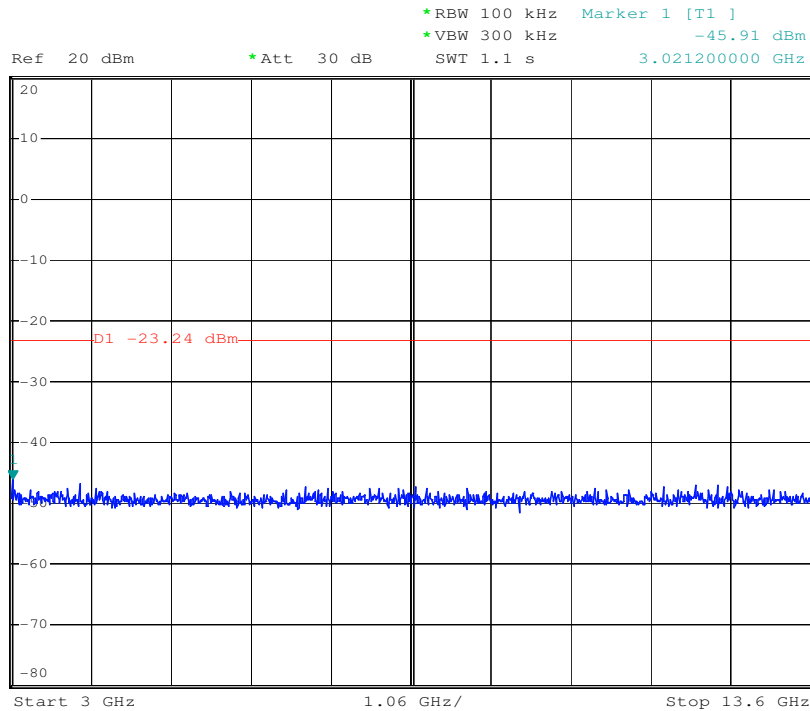

3GHz-13.6GHz:



13.6GHz-25GHz: 

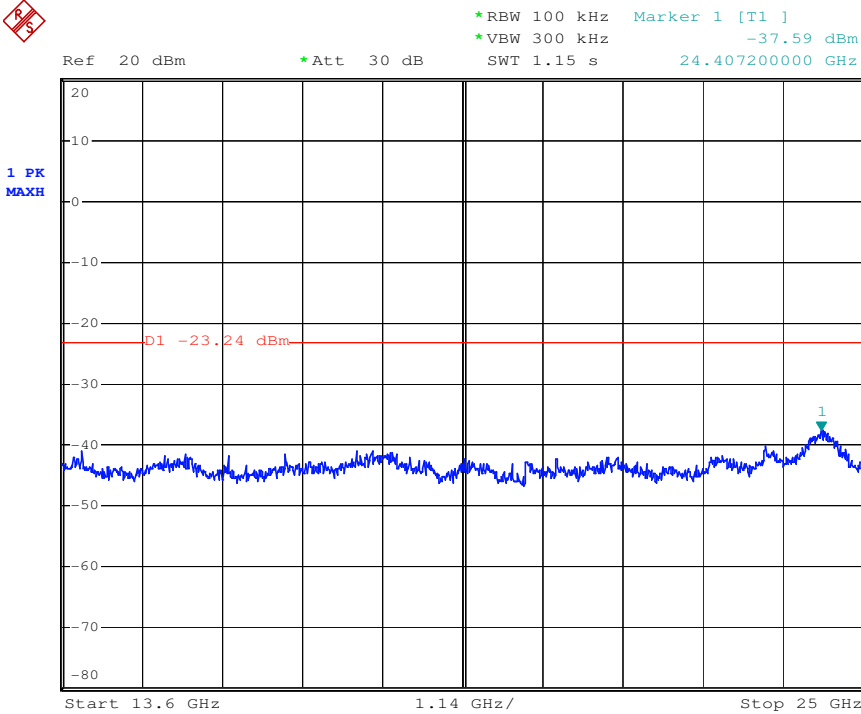

Test mode:	8DPSK	Test channel:	Middle
------------	-------	---------------	--------

30MHz-3GHz: 

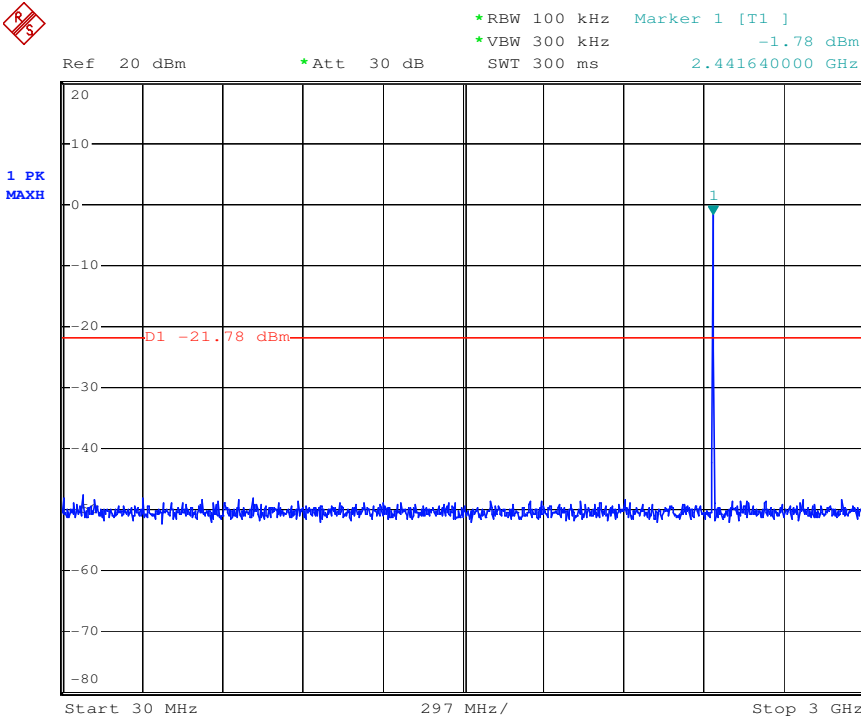

This document is issued by the Company subject to its General Conditions of Service printed overleaf, available on request or accessible at [www.sgs.com/terms\\_and\\_conditions.htm](http://www.sgs.com/terms_and_conditions.htm) and, for electronic format documents, subject to Terms and Conditions for Electronic Documents at [www.sgs.com/terms\\_e-document.htm](http://www.sgs.com/terms_e-document.htm). Attention is drawn to the limitation of liability, indemnification and jurisdiction issues defined therein. Any holder of this document is advised that information contained hereon reflects the Company's findings at the time of its intervention only and within the limits of Client's instructions, if any. The Company's sole responsibility is to its Client and this document does not exonerate parties to a transaction from exercising all their rights and obligations under the transaction documents. This document cannot be reproduced except in full, without prior written approval of the Company. Any unauthorized alteration, forgery or falsification of the content or appearance of this document is unlawful and offenders may be prosecuted to the fullest extent of the law. Unless otherwise stated the results shown in this test report refer only to the sample(s) tested and such sample(s) are retained for 90 days only

3GHz-13.6GHz:

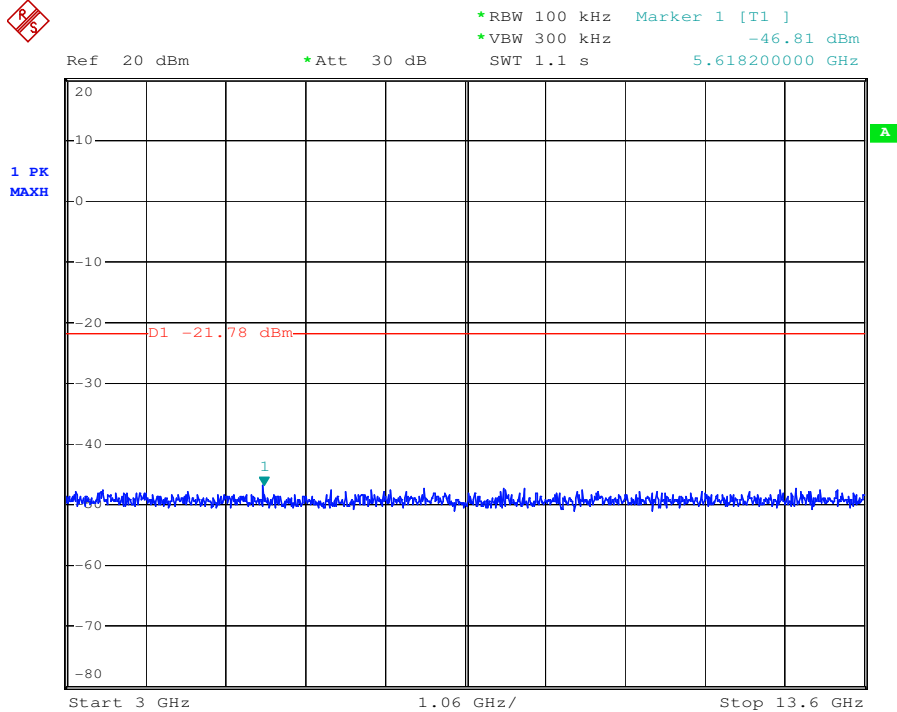

13.6GHz-25GHz:

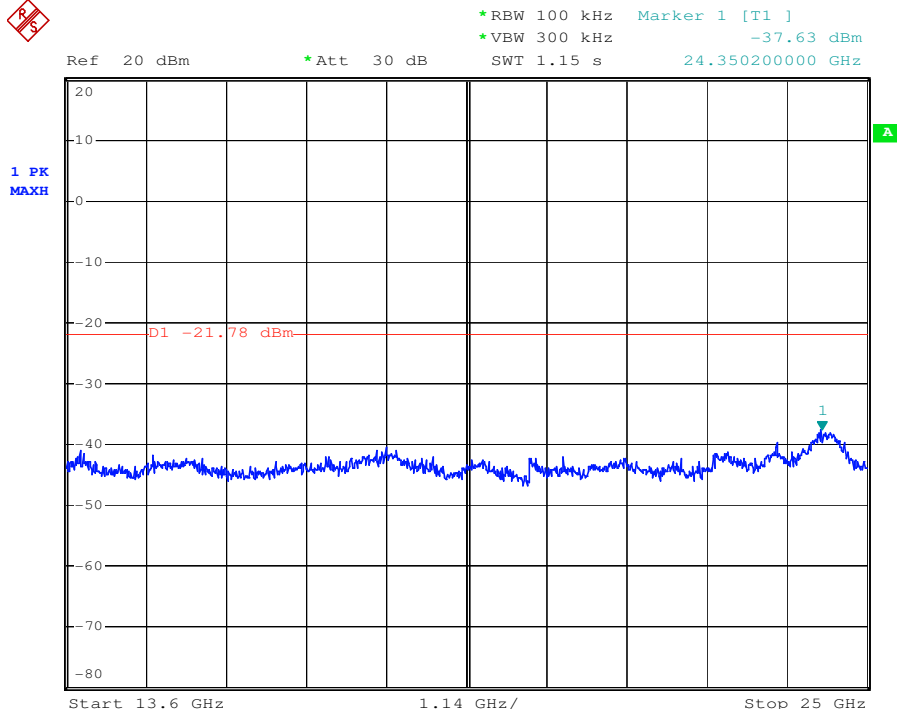

This document is issued by the Company subject to its General Conditions of Service printed overleaf, available on request or accessible at [www.sgs.com/terms\\_and\\_conditions.htm](http://www.sgs.com/terms_and_conditions.htm) and, for electronic format documents, subject to Terms and Conditions for Electronic Documents at [www.sgs.com/terms\\_e-document.htm](http://www.sgs.com/terms_e-document.htm). Attention is drawn to the limitation of liability, indemnification and jurisdiction issues defined therein. Any holder of this document is advised that information contained hereon reflects the Company's findings at the time of its intervention only and within the limits of Client's instructions, if any. The Company's sole responsibility is to its Client and this document does not exonerate parties to a transaction from exercising all their rights and obligations under the transaction documents. This document cannot be reproduced except in full, without prior written approval of the Company. Any unauthorized alteration, forgery or falsification of the content or appearance of this document is unlawful and offenders may be prosecuted to the fullest extent of the law. Unless otherwise stated the results shown in this test report refer only to the sample(s) tested and such sample(s) are retained for 90 days only

Test mode:	8DPSK	Test channel:	Highest
------------	-------	---------------	---------

30MHz-3GHz:

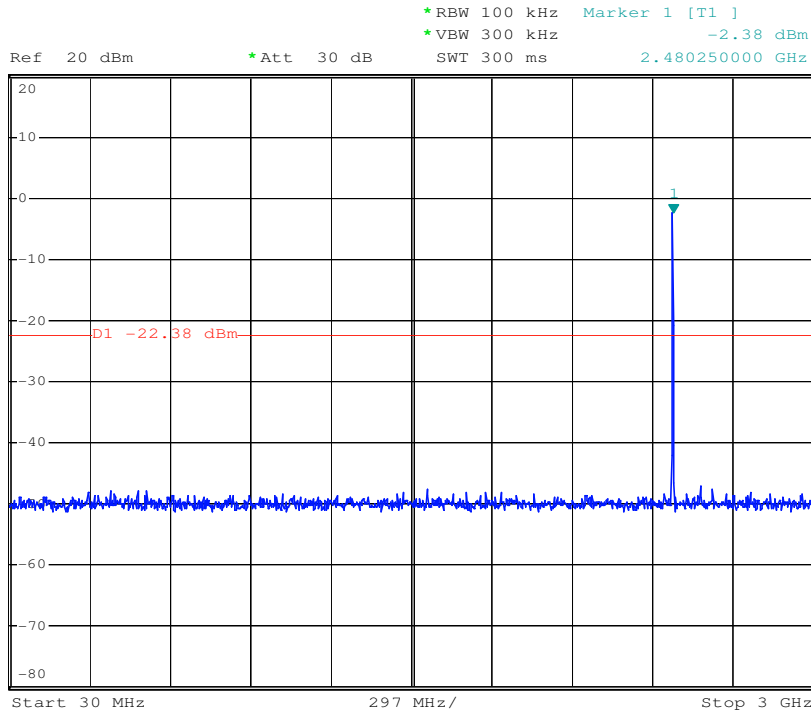

3GHz-13.6GHz:

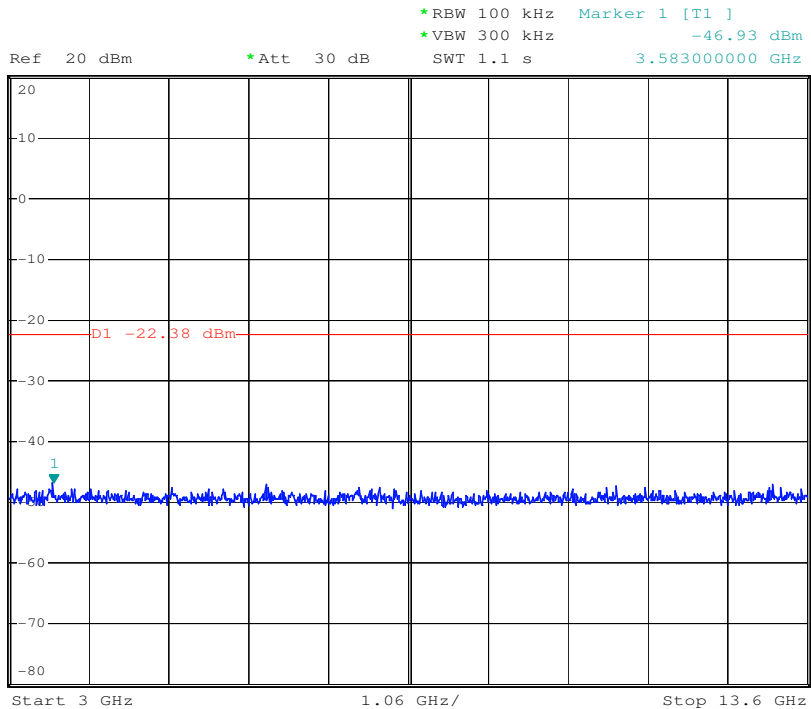

13.6GHz-25GHz: 

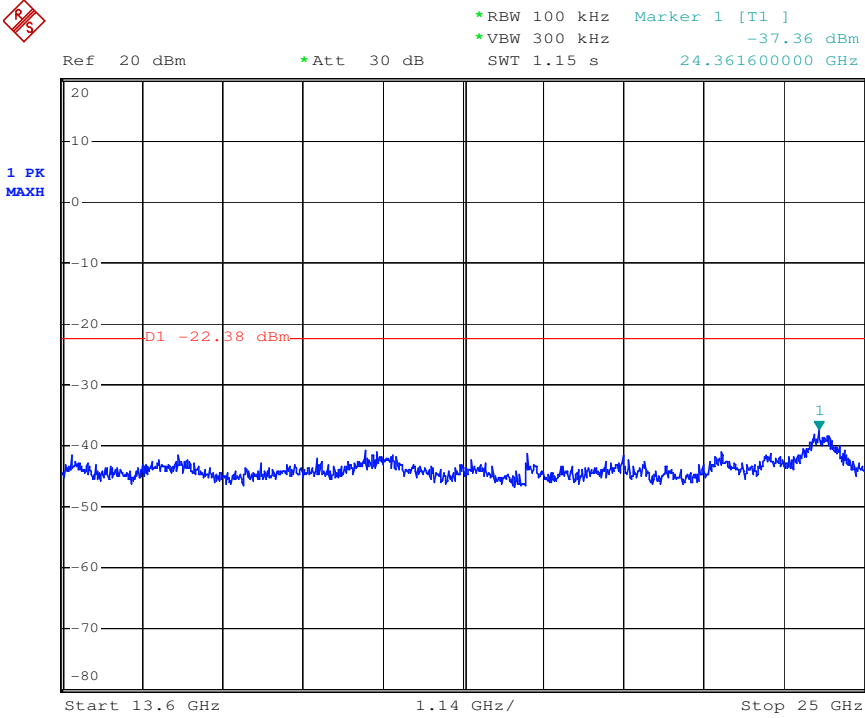

This document is issued by the Company subject to its General Conditions of Service printed overleaf, available on request or accessible at [www.sgs.com/terms\\_and\\_conditions.htm](http://www.sgs.com/terms_and_conditions.htm) and, for electronic format documents, subject to Terms and Conditions for Electronic Documents at [www.sgs.com/terms\\_e-document.htm](http://www.sgs.com/terms_e-document.htm). Attention is drawn to the limitation of liability, indemnification and jurisdiction issues defined therein. Any holder of this document is advised that information contained hereon reflects the Company's findings at the time of its intervention only and within the limits of Client's instructions, if any. The Company's sole responsibility is to its Client and this document does not exonerate parties to a transaction from exercising all their rights and obligations under the transaction documents. This document cannot be reproduced except in full, without prior written approval of the Company. Any unauthorized alteration, forgery or falsification of the content or appearance of this document is unlawful and offenders may be prosecuted to the fullest extent of the law. Unless otherwise stated the results shown in this test report refer only to the sample(s) tested and such sample(s) are retained for 90 days only

### 7.10.2 Conducted Band-edge

Test plot as follows:

Test mode:	GFSK	Test channel:	Hopping enabled
------------	------	---------------	-----------------

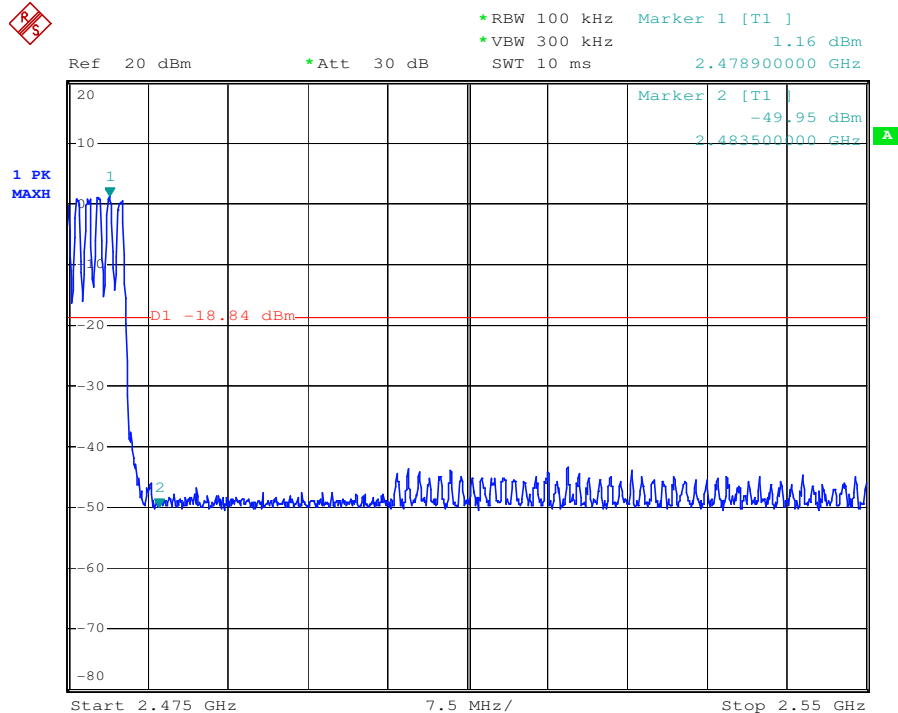
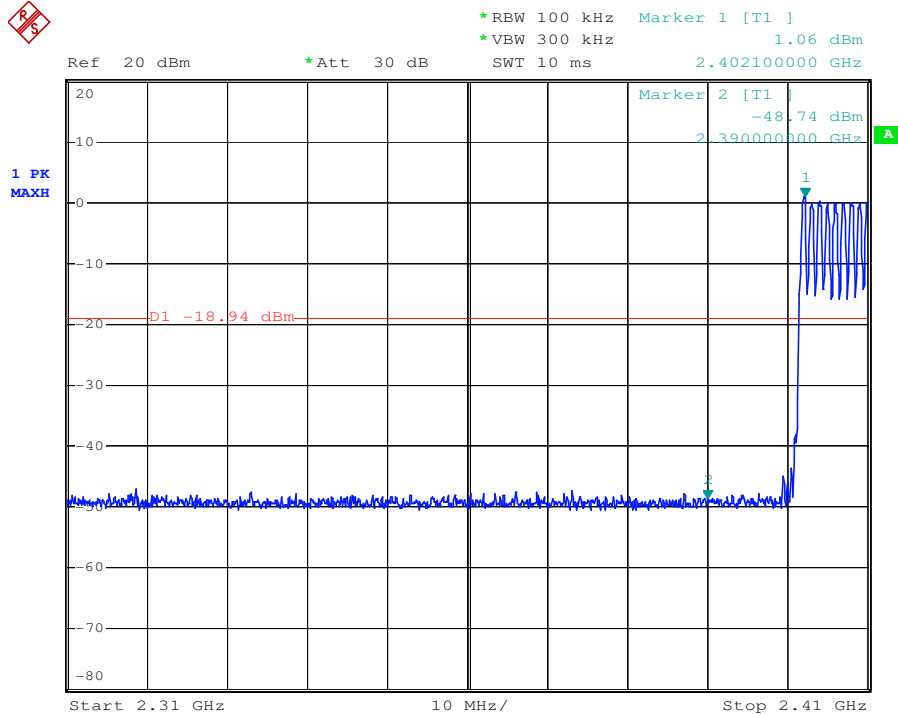

This document is issued by the Company subject to its General Conditions of Service printed overleaf, available on request or accessible at [www.sgs.com/terms\\_and\\_conditions.htm](http://www.sgs.com/terms_and_conditions.htm) and, for electronic format documents, subject to Terms and Conditions for Electronic Documents at [www.sgs.com/terms\\_e-document.htm](http://www.sgs.com/terms_e-document.htm). Attention is drawn to the limitation of liability, indemnification and jurisdiction issues defined therein. Any holder of this document is advised that information contained hereon reflects the Company's findings at the time of its intervention only and within the limits of Client's instructions, if any. The Company's sole responsibility is to its Client and this document does not exonerate parties to a transaction from exercising all their rights and obligations under the transaction documents. This document cannot be reproduced except in full, without prior written approval of the Company. Any unauthorized alteration, forgery or falsification of the content or appearance of this document is unlawful and offenders may be prosecuted to the fullest extent of the law. Unless otherwise stated the results shown in this test report refer only to the sample(s) tested and such sample(s) are retained for 90 days only

Test mode:	$\pi/4$ DQPSK	Test channel:	Hopping enabled
------------	---------------	---------------	-----------------

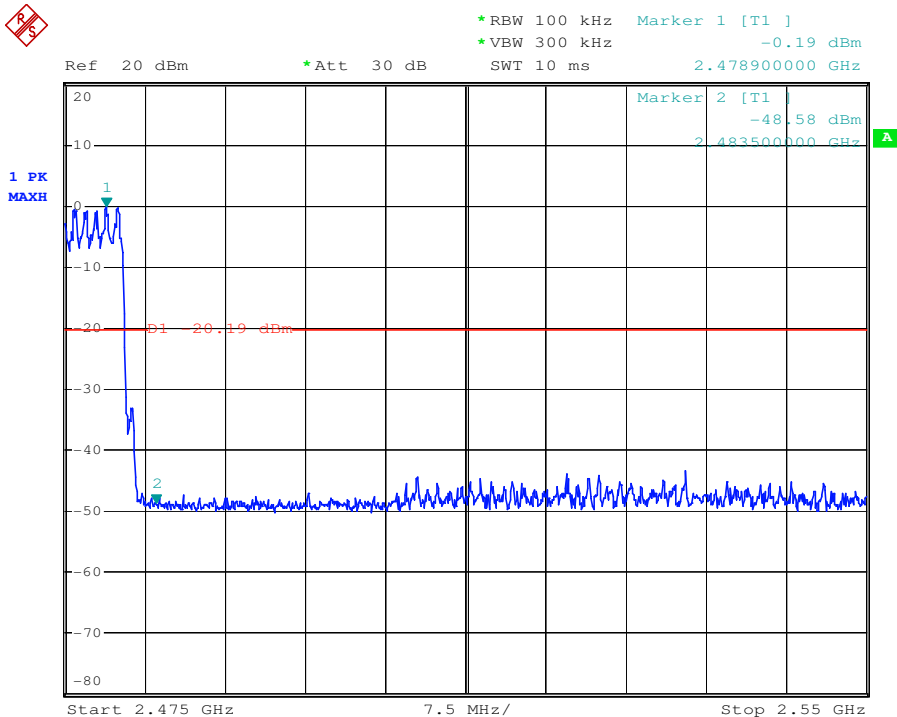
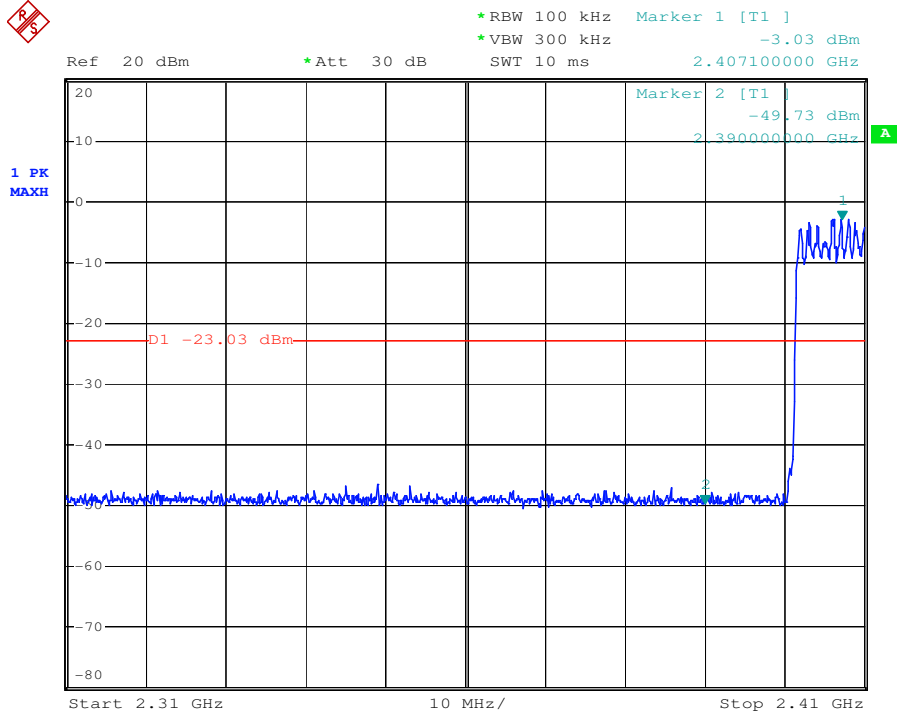

This document is issued by the Company subject to its General Conditions of Service printed overleaf, available on request or accessible at [www.sgs.com/terms\\_and\\_conditions.htm](http://www.sgs.com/terms_and_conditions.htm) and, for electronic format documents, subject to Terms and Conditions for Electronic Documents at [www.sgs.com/terms\\_e-document.htm](http://www.sgs.com/terms_e-document.htm). Attention is drawn to the limitation of liability, indemnification and jurisdiction issues defined therein. Any holder of this document is advised that information contained hereon reflects the Company's findings at the time of its intervention only and within the limits of Client's instructions, if any. The Company's sole responsibility is to its Client and this document does not exonerate parties to a transaction from exercising all their rights and obligations under the transaction documents. This document cannot be reproduced except in full, without prior written approval of the Company. Any unauthorized alteration, forgery or falsification of the content or appearance of this document is unlawful and offenders may be prosecuted to the fullest extent of the law. Unless otherwise stated the results shown in this test report refer only to the sample(s) tested and such sample(s) are retained for 90 days only

Test mode:	8DPSK	Test channel:	Hopping enabled
------------	-------	---------------	-----------------



Ref 20 dBm \*Att 30 dB SWT 10 ms  
 \*RBW 100 kHz Marker 1 [T1] -2.86 dBm  
 \*VBW 300 kHz 2.408000000 GHz

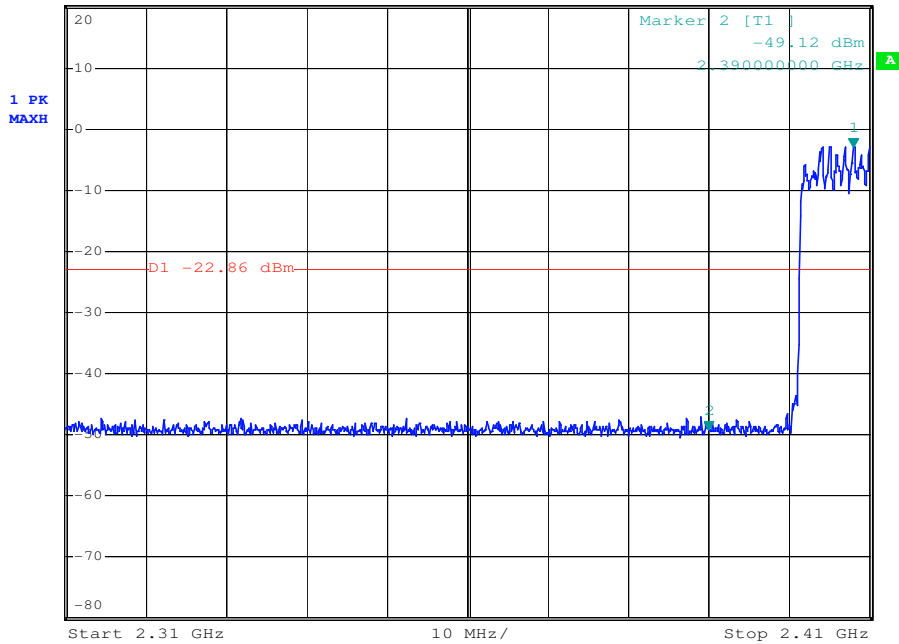

Ref 20 dBm \*Att 30 dB SWT 10 ms  
 \*RBW 100 kHz Marker 1 [T1] -0.24 dBm  
 \*VBW 300 kHz 2.478900000 GHz

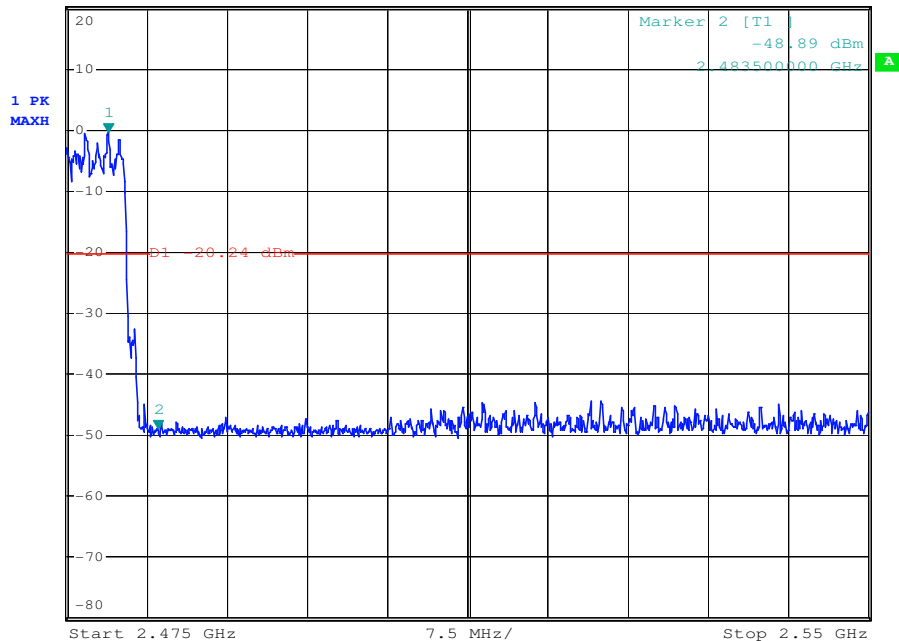

This document is issued by the Company subject to its General Conditions of Service printed overleaf, available on request or accessible at [www.sgs.com/terms\\_and\\_conditions.htm](http://www.sgs.com/terms_and_conditions.htm) and, for electronic format documents, subject to Terms and Conditions for Electronic Documents at [www.sgs.com/terms\\_e-document.htm](http://www.sgs.com/terms_e-document.htm). Attention is drawn to the limitation of liability, indemnification and jurisdiction issues defined therein. Any holder of this document is advised that information contained hereon reflects the Company's findings at the time of its intervention only and within the limits of Client's instructions, if any. The Company's sole responsibility is to its Client and this document does not exonerate parties to a transaction from exercising all their rights and obligations under the transaction documents. This document cannot be reproduced except in full, without prior written approval of the Company. Any unauthorized alteration, forgery or falsification of the content or appearance of this document is unlawful and offenders may be prosecuted to the fullest extent of the law. Unless otherwise stated the results shown in this test report refer only to the sample(s) tested and such sample(s) are retained for 90 days only



Test mode:	GFSK	Test channel:	Hopping disabled- Lowest
------------	------	---------------	--------------------------

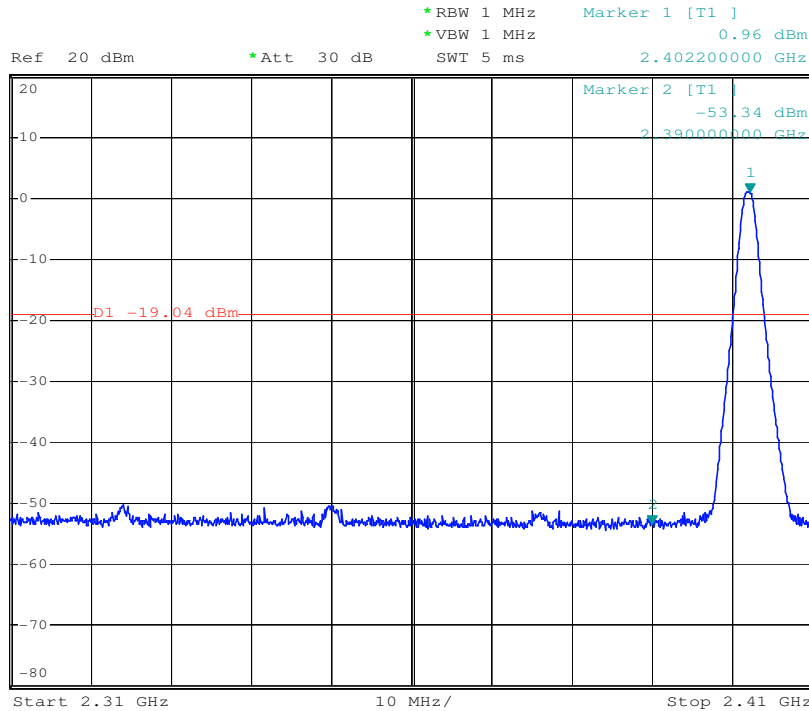

Test mode:	GFSK	Test channel:	Hopping disabled- Highest
------------	------	---------------	---------------------------

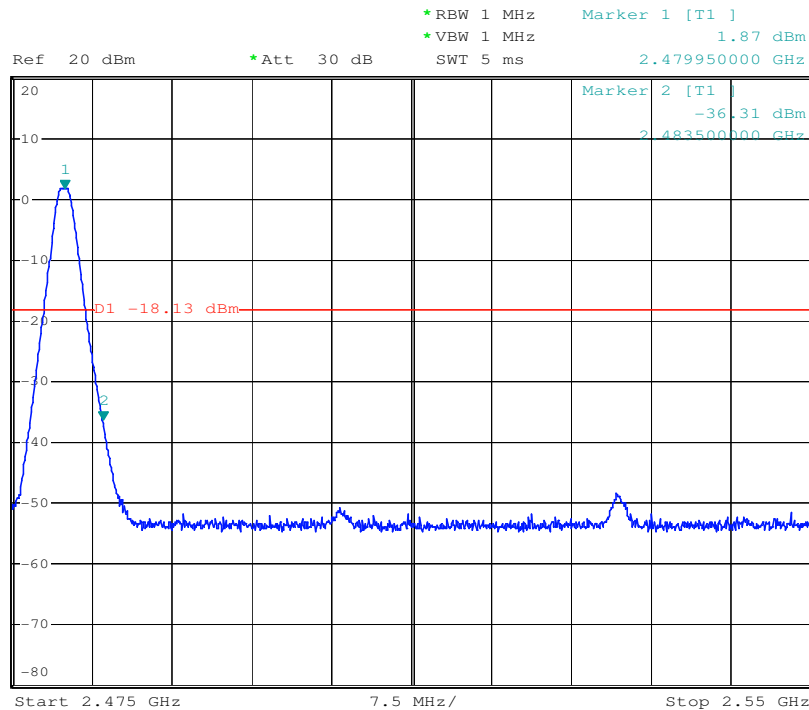

This document is issued by the Company subject to its General Conditions of Service printed overleaf, available on request or accessible at [www.sgs.com/terms\\_and\\_conditions.htm](http://www.sgs.com/terms_and_conditions.htm) and, for electronic format documents, subject to Terms and Conditions for Electronic Documents at [www.sgs.com/terms\\_e-document.htm](http://www.sgs.com/terms_e-document.htm). Attention is drawn to the limitation of liability, indemnification and jurisdiction issues defined therein. Any holder of this document is advised that information contained herein reflects the Company's findings at the time of its intervention only and within the limits of Client's instructions, if any. The Company's sole responsibility is to its Client and this document does not exonerate parties to a transaction from exercising all their rights and obligations under the transaction documents. This document cannot be reproduced except in full, without prior written approval of the Company. Any unauthorized alteration, forgery or falsification of the content or appearance of this document is unlawful and offenders may be prosecuted to the fullest extent of the law. Unless otherwise stated the results shown in this test report refer only to the sample(s) tested and such sample(s) are retained for 90 days only

Test mode:	$\pi/4$ DQPSK	Test channel:	Hopping disabled- Lowest
------------	---------------	---------------	--------------------------



Ref 20 dBm      \*Att 30 dB      \*RBW 1 MHz      Marker 1 [T1]      -0.93 dBm  
 \*VBW 1 MHz      2.402100000 GHz  
 SWT 5 ms

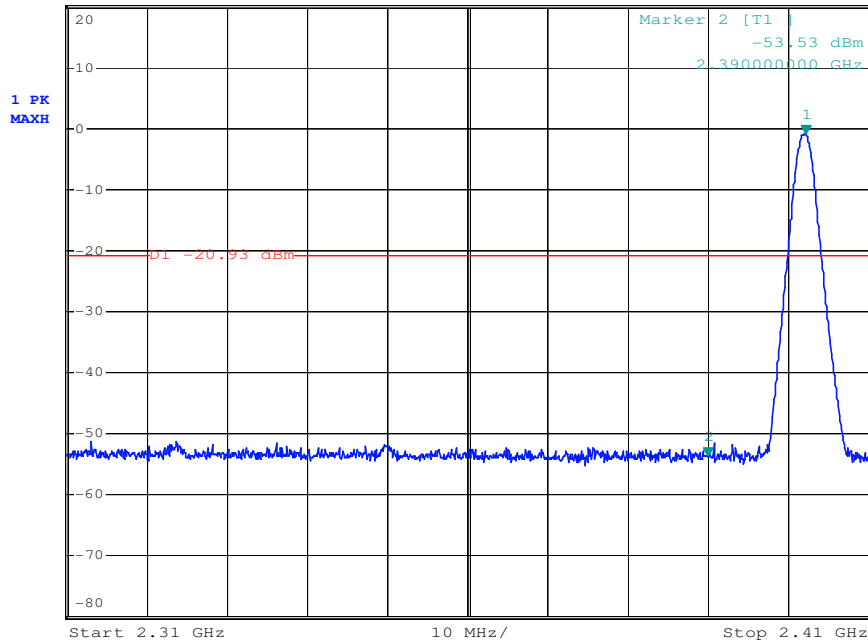

Test mode:	$\pi/4$ DQPSK	Test channel:	Hopping disabled- Highest
------------	---------------	---------------	---------------------------



Ref 20 dBm      \*Att 30 dB      \*RBW 1 MHz      Marker 1 [T1]      1.28 dBm  
 \*VBW 1 MHz      2.479650000 GHz  
 SWT 5 ms

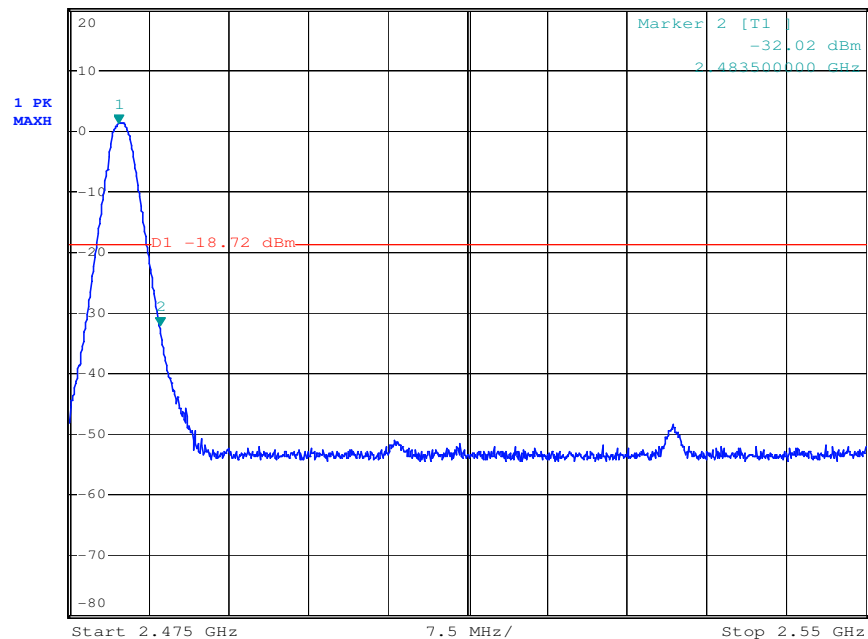

This document is issued by the Company subject to its General Conditions of Service printed overleaf, available on request or accessible at [www.sgs.com/terms\\_and\\_conditions.htm](http://www.sgs.com/terms_and_conditions.htm) and, for electronic format documents, subject to Terms and Conditions for Electronic Documents at [www.sgs.com/terms\\_e-document.htm](http://www.sgs.com/terms_e-document.htm). Attention is drawn to the limitation of liability, indemnification and jurisdiction issues defined therein. Any holder of this document is advised that information contained hereon reflects the Company's findings at the time of its intervention only and within the limits of Client's instructions, if any. The Company's sole responsibility is to its Client and this document does not exonerate parties to a transaction from exercising all their rights and obligations under the transaction documents. This document cannot be reproduced except in full, without prior written approval of the Company. Any unauthorized alteration, forgery or falsification of the content or appearance of this document is unlawful and offenders may be prosecuted to the fullest extent of the law. Unless otherwise stated the results shown in this test report refer only to the sample(s) tested and such sample(s) are retained for 90 days only

Test mode:	8DPSK	Test channel:	Hopping disabled- Lowest
------------	-------	---------------	--------------------------



Ref 20 dBm      \*Att 30 dB      \*RBW 1 MHz      Marker 1 [T1]      -0.95 dBm  
 \*VBW 1 MHz      2.401800000 GHz  
 SWT 5 ms

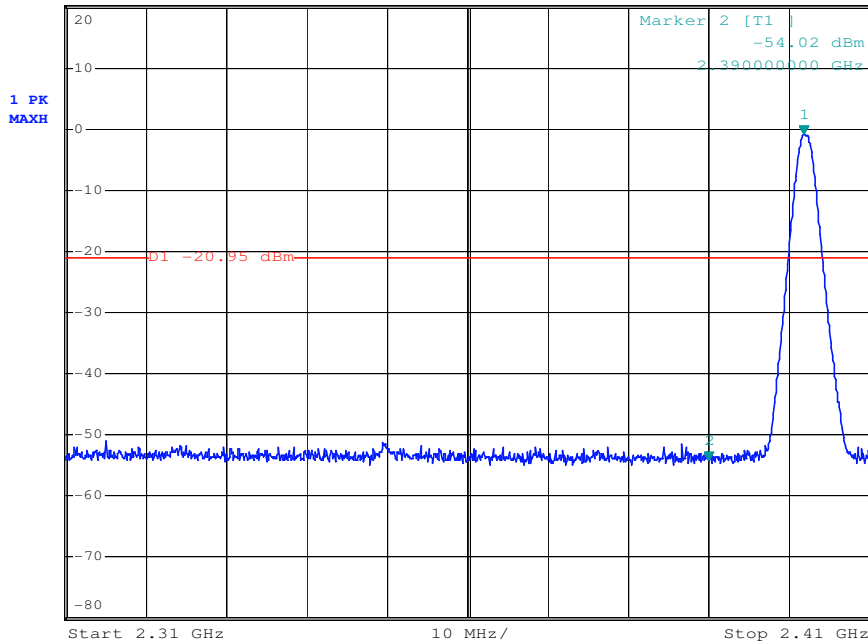

Test mode:	8DPSK	Test channel:	Hopping disabled- Highest
------------	-------	---------------	---------------------------



Ref 20 dBm      \*Att 30 dB      \*RBW 1 MHz      Marker 1 [T1]      1.26 dBm  
 \*VBW 1 MHz      2.479650000 GHz  
 SWT 5 ms

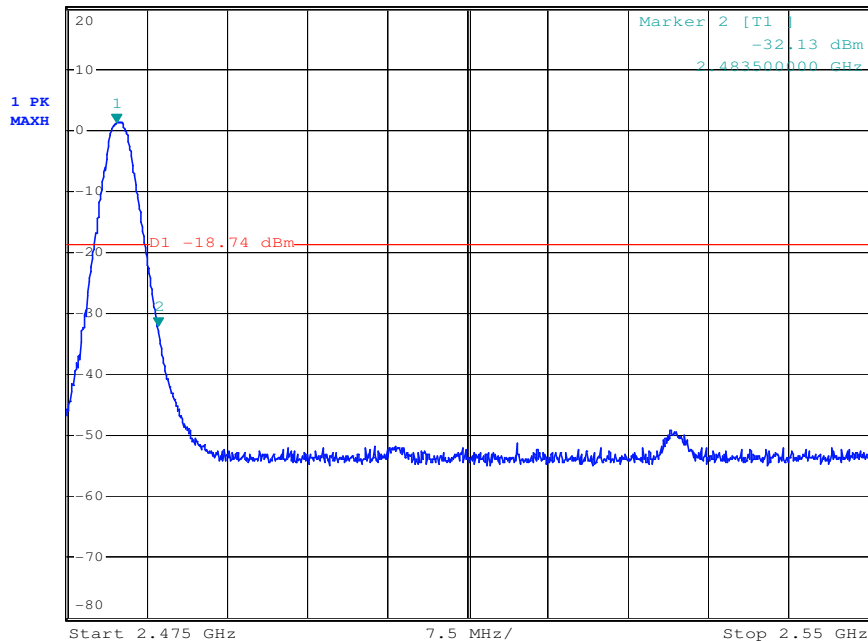

This document is issued by the Company subject to its General Conditions of Service printed overleaf, available on request or accessible at [www.sgs.com/terms\\_and\\_conditions.htm](http://www.sgs.com/terms_and_conditions.htm) and, for electronic format documents, subject to Terms and Conditions for Electronic Documents at [www.sgs.com/terms\\_e-document.htm](http://www.sgs.com/terms_e-document.htm). Attention is drawn to the limitation of liability, indemnification and jurisdiction issues defined therein. Any holder of this document is advised that information contained herein reflects the Company's findings at the time of its intervention only and within the limits of Client's instructions, if any. The Company's sole responsibility is to its Client and this document does not exonerate parties to a transaction from exercising all their rights and obligations under the transaction documents. This document cannot be reproduced except in full, without prior written approval of the Company. Any unauthorized alteration, forgery or falsification of the content or appearance of this document is unlawful and offenders may be prosecuted to the fullest extent of the law. Unless otherwise stated the results shown in this test report refer only to the sample(s) tested and such sample(s) are retained for 90 days only

### 7.11 Radiated Spurious Emissions and Band-edge

**Frequency Range:** 9KHz to 25GHz

**Test site/setup:**

Measurement Distance: 3m (Semi-Anechoic Chamber)

Test instrumentation set-up:

Frequency Range	Detector	RBW	VBW
0.009MHz-0.090MHz	Peak	10kHz	30kHz
0.009MHz-0.090MHz	Average	10kHz	30kHz
0.090MHz-0.110MHz	Quasi-peak	10kHz	30kHz
0.110MHz-0.490MHz	Peak	10kHz	30kHz
0.110MHz-0.490MHz	Average	10kHz	30kHz
0.490MHz -30MHz	Quasi-peak	10kHz	30kHz
30MHz-1GHz	Quasi-peak	100kHz	300kHz
Above 1GHz	Peak	RBW=1MHz	VBW≥RBW
	Average		VBW=10Hz

Sweep=Auto

**15.209 Limit:**

Frequency	Limit (dBuV/m)
0.009MHz-0.490MHz	128.5 ~ 93.8
0.490MHz-1.705MHz	73.8 ~63.0
1.705MHz-30MHz	69.5
30MHz-88MHz	40.0
88MHz-216MHz	43.5
216MHz-960MHz	46.0
960MHz-1GHz	54.0
Above 1GHz	54.0

Note: 15.35(b), Unless otherwise specified, the limit on peak radio frequency emissions is 20dB above the maximum permitted average emission limit applicable to the equipment under test. This peak limit applies to the total peak emission level radiated by the device.

**Test Configuration:** Receive antenna scan height 1 m - 4 m. polarization Vertical / Horizontal

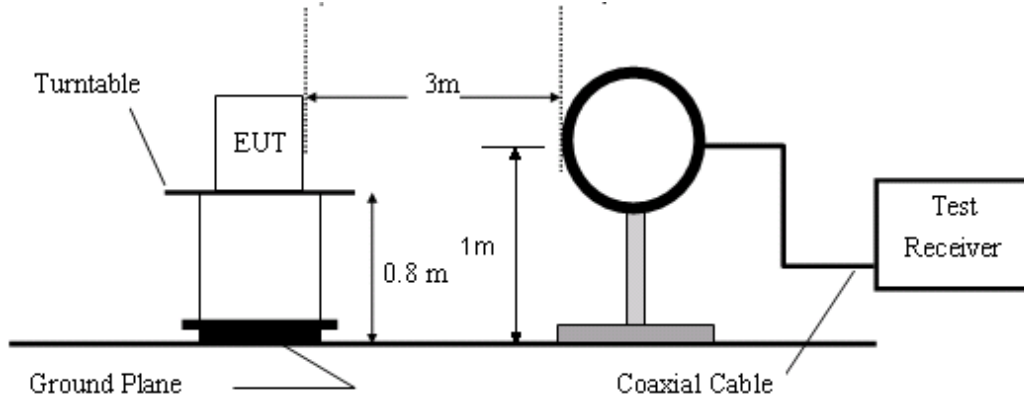

**Figure1. 30MHz to 1GHz radiated emissions test configuration**

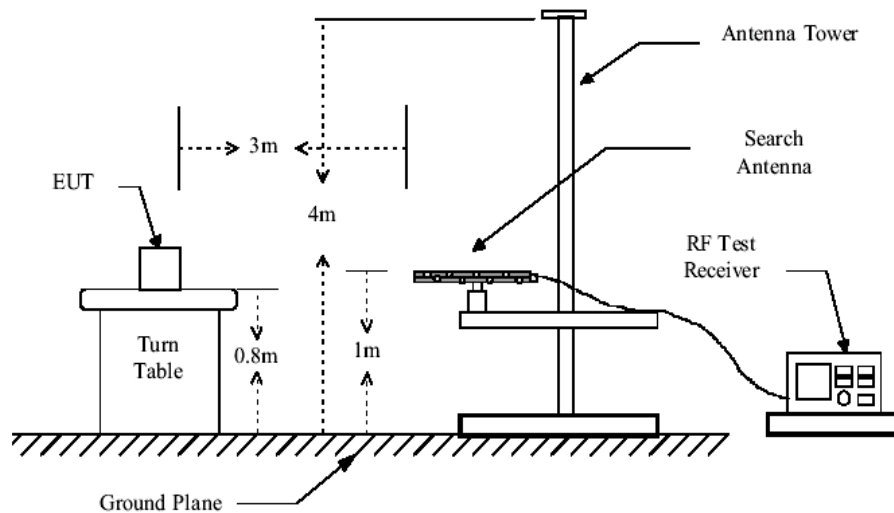

**Figure2. 30MHz to 1GHz radiated emissions test configuration**

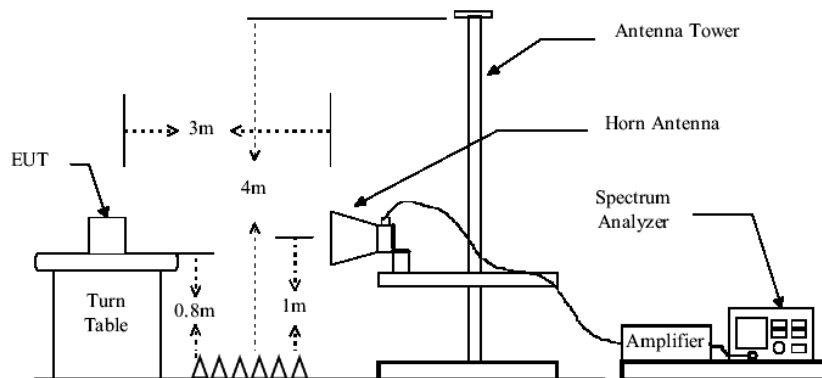

**Figure3. Above 1GHz radiated emissions test configuration**

**Test Procedure:** The procedure used was ANSI Standard C63.10:2009. The receiver was scanned from 9KHz to 25GHz. When an emission was found, the table was rotated to produce the maximum signal strength. An initial pre-scan was performed for in peak detection mode using the receiver. The EUT was measured for both the Horizontal and Vertical polarities and performed a pre-test three orthogonal planes. For intentional radiators, measurements of the variation of the input power or the radiated signal level of the fundamental frequency component of the emission, as appropriate, shall be performed with the supply voltage varied between 85% and 115% of the nominal rated supply voltage. The worst case emissions were reported.

Low noise amplifier was used below 1GHz, High pass Filter was used above 3GHz.

Between 1G and 3GHz, we did not use any amplifier or filter.

Pre-test was performed on all modes, Compliance test was performed on worse case (8DPSK mode).

Test were performed for their spatial orthogonal(X, Y, Z), the worst test data (X orthogonal) was submitted.

- 1) For this intentional radiator operates below 25 GHz. the spectrum shall be investigated to the tenth harmonic of the highest fundamental frequency. And above the third harmonic of this intentional radiator, the disturbance is very low. So the test result only displays to 5rd harmonic.
- 2) As shown in Section, for frequencies above 1000MHz. the above field strength limits are based on average limits. However, the peak field strength of any emission shall not exceed the maximum permitted average limits specified above by more than 20 dB under any condition of modulation.

The test only perform the EUT in transmitting status since the test frequencies were over 1GHz only required transmitting status.

**Test Result:** Pass

**7.11.1 Radiated Spurious Emissions:**

30MHz-1GHz:  
Vertical:

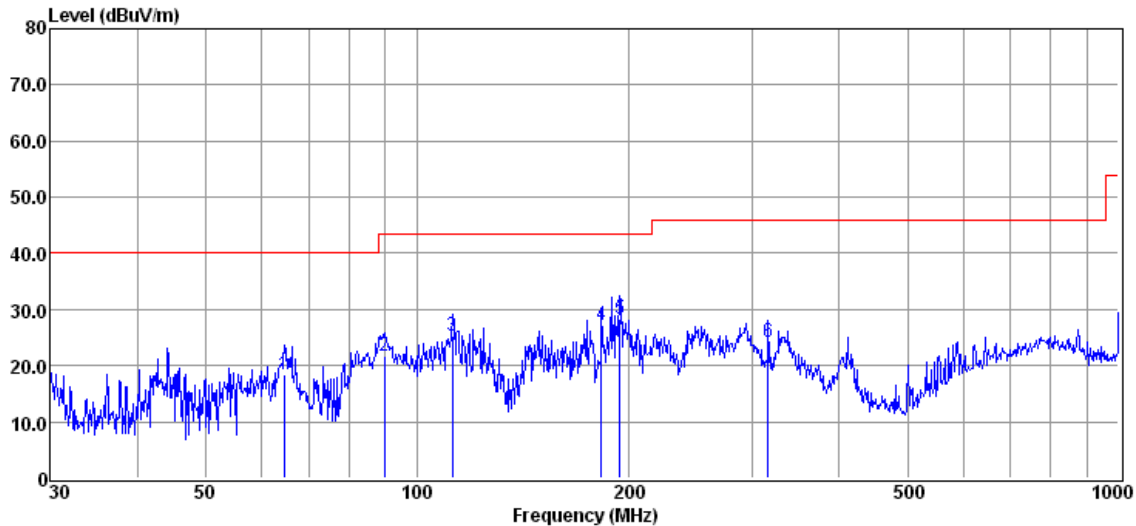

Item	Freq.	Read Level	Antenna Factor	Preamp Factor	Cable Loss	Result Level	Limit Line	Over Limit	Detector
(Mark)	(MHz)	(dB $\mu$ V)	(dB/m)	(dB)	(dB)	(dB $\mu$ V/m)	(dB $\mu$ V/m)	(dB)	
1	64.659	30.14	11.53	23.68	0.55	18.54	40.00	-21.46	QP
2	89.905	36.27	8.32	23.67	0.81	21.73	43.50	-21.77	QP
3	112.130	37.16	10.67	23.65	0.99	25.17	43.50	-18.33	QP
4	183.201	37.56	11.88	23.62	1.35	27.17	43.50	-16.33	QP
5	194.453	40.07	10.52	23.62	1.38	28.35	43.50	-15.15	QP
6	316.589	33.16	12.66	23.67	1.92	24.07	46.00	-21.93	QP

Horizontal:

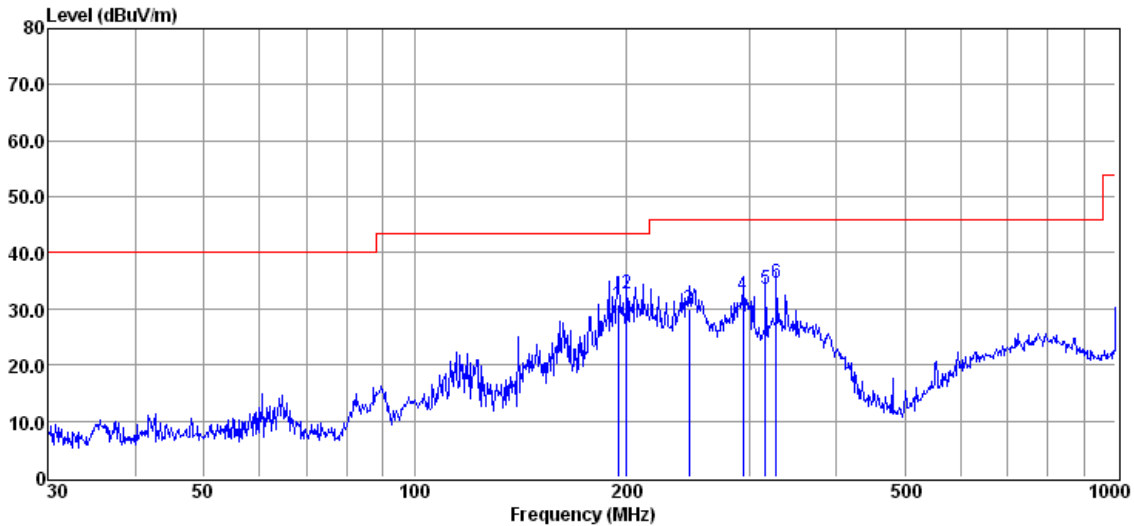

Item	Freq.	Read Level	Antenna Factor	Preamp Factor	Cable Loss	Result Level	Limit Line	Over Limit	Detector
(Mark)	(MHz)	(dBμV)	(dB/m)	(dB)	(dB)	(dBμV/m)	(dBμV/m)	(dB)	
1	195.136	42.69	10.35	23.62	1.38	30.80	43.50	-12.70	QP
2	200.688	45.69	9.28	23.62	1.40	32.75	43.50	-10.75	QP
3	245.951	41.90	10.22	23.65	1.55	30.02	46.00	-15.98	QP
4	294.114	42.62	11.58	23.67	1.82	32.35	46.00	-13.65	QP
5	316.589	42.69	12.66	23.67	1.92	33.60	46.00	-12.40	QP
6	327.887	43.17	13.11	23.68	1.92	34.52	46.00	-11.48	QP

$$\text{Result Level} = \text{Read Level} + \text{Antenna Factor} + \text{Cable loss} - \text{Preamp Factor}$$



Above 1GHz:

**Lowest Channel(2402MHz)**

Mark	Frequency (MHz)	Reading (dBuV)	Factor (dB)	Emission (dBuV/m)	Limit (dBuV/m)	Over Limit (dB)	Detector	Polarization
1	4804.00	44.00	5.72	49.72	54	-4.28	peak	Horizontal
2	7205.00	43.74	9.28	53.02	54	-0.98	peak	Horizontal
3	9605.00	42.16	13.31	51.47	54	-3.53	peak	Horizontal
4	4805.20	49.61	5.67	50.28	54	-3.72	peak	Vertical
5	7205.00	42.45	9.44	51.89	54	-2.11	peak	Vertical
6	9610.00	43.49	13.4	52.89	54	-1.11	peak	Vertical

**Middle Channel(2441MHz)**

Mark	Frequency (MHz)	Reading (dBuV)	Factor (dB)	Emission (dBuV/m)	Limit (dBuV/m)	Over Limit (dB)	Detector	Polarization
1	4880.80	48.59	6.32	52.91	54	-1.09	peak	Horizontal
2	7320.00	45.09	9.59	51.68	54	-2.32	peak	Horizontal
3	9765.00	42.98	13.43	52.41	54	-1.59	peak	Horizontal
4	4880.80	53.86	6.28	53.14	54	-0.86	peak	Vertical
5	7323.00	43.71	9.72	53.43	54	-0.57	peak	Vertical
6	9764.00	42.53	13.47	52.00	54	-2.00	peak	Vertical

**Highest Channel(2480MHz)**

Mark	Frequency (MHz)	Reading (dBuV)	Factor (dB)	Emission (dBuV/m)	Limit (dBuV/m)	Over Limit (dB)	Detector	Polarization
1	4956.40	51.59	6.52	53.11	54	-0.89	peak	Horizontal
2	7440.00	43.65	10.01	53.66	54	-0.34	peak	Horizontal
3	9920.00	42.36	13.60	52.96	54	-1.04	peak	Horizontal
4	4956.40	54.10	6.51	51.61	54	-2.39	peak	Vertical
5	7440.00	43.12	10.12	53.24	54	-0.76	peak	Vertical
6	9920.00	42.42	13.62	52.04	54	-1.96	peak	Vertical

- Remark: 1. Test Level =Receiver Reading + Antenna Factor + Cable Loss –Preamplifier Factor.  
 2. No any other emissions level which are attenuated less than 20dB below the limit. According to 15.31(o), the amplitude of spurious emissions from intentional radiators and emissions from unintentional radiators which are attenuated more than 20 dB below the permissible value need not be reported unless specifically required elsewhere in this Part. Hence there no other emissions have been reported.  
 3. If the Peak value below the AV Limit, the AV test doesn't perform for this submission.

**7.11.2 Radiated Band edge**

**Lowest Channel(2402MHz)**

**Modulation: GFSK**

MK.	Frequency (MHz)	Reading (dBuV/m)	Corrected factor(dB)	Result (dBuV/m)	Limit (dBuV/m)	Over Limit (dB)	Detector	Polarization
1	2345.8	46.37	-4.99	41.38	74	-32.62	Peak	Horizontal
2	2390	45.13	-5.24	39.89	74	-34.11	Peak	Horizontal
3	2400	72.31	-5.29	67.02	74	-6.98	Peak	Horizontal
4	2402	93.72	-5.30	88.42	74	14.42	Peak	Horizontal
1	2341.4	32.03	-4.97	27.06	54	-26.94	Average	Horizontal
2	2390	31.94	-5.24	26.7	54	-27.3	Average	Horizontal
3	2400	43.25	-5.29	37.96	54	-16.04	Average	Horizontal
4	2402	51.40	-5.30	46.10	54	-7.90	Average	Horizontal

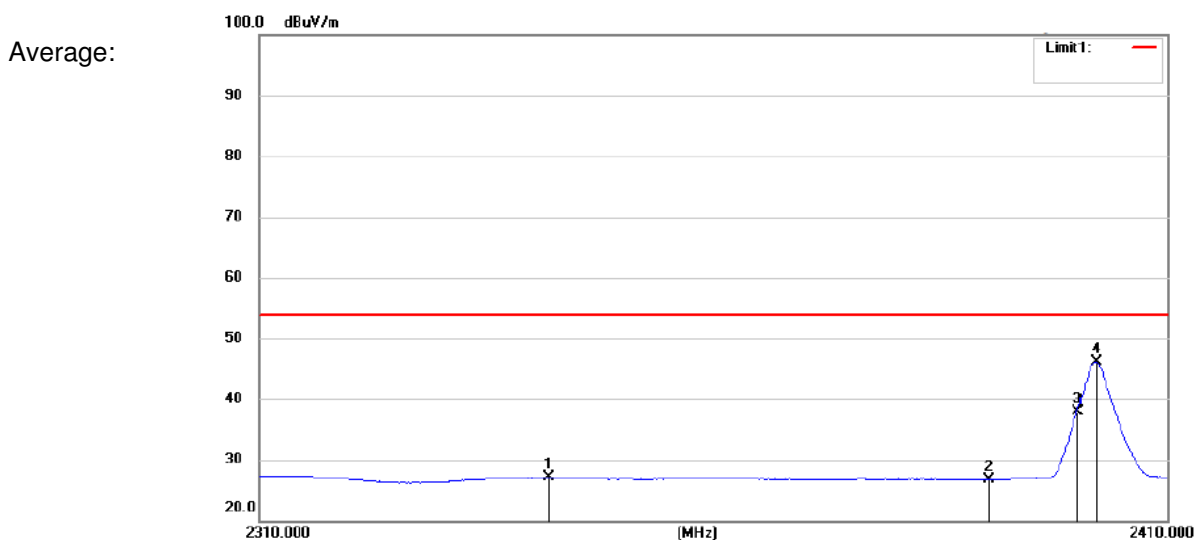
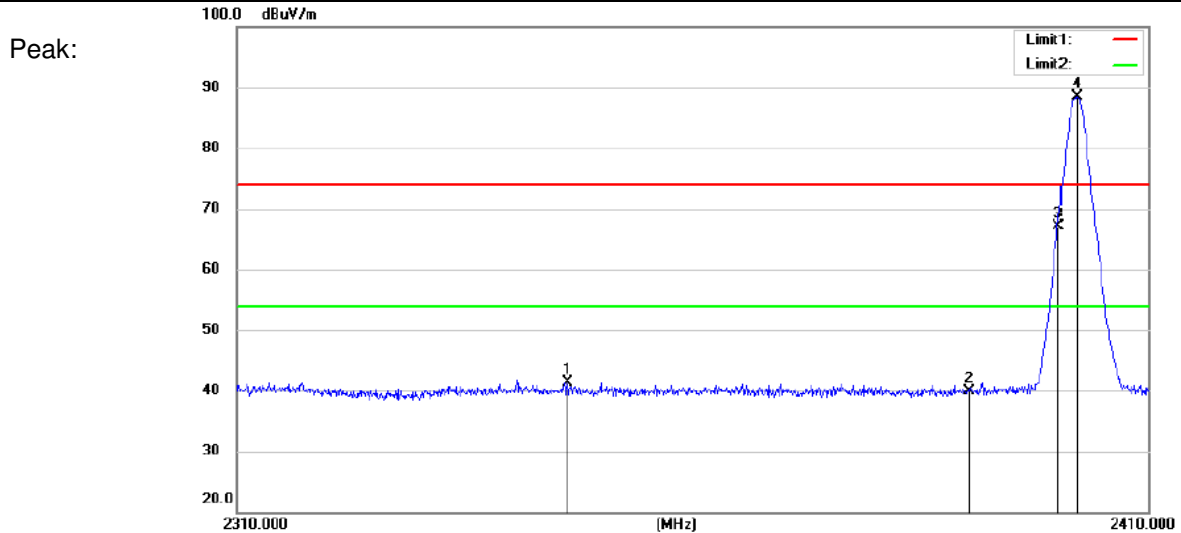

**Lowest Channel(2402MHz)**

**Modulation: GFSK**

MK.	Frequency (MHz)	Reading (dBuV/m)	Corrected factor(dB)	Result (dBuV/m)	Limit (dBuV/m)	Over Limit (dB)	Detector	Polarization
1	2338.3	46.90	-4.95	41.95	74	-32.05	Peak	Vertical
2	2390	46.39	-5.24	41.15	74	-32.85	Peak	Vertical
3	2400	76.70	-5.29	71.41	74	-2.59	Peak	Vertical
4	2402	98.00	-5.3	92.7	74	18.7	Peak	Vertical
1	2349.89	32.99	-5.02	27.97	54	-26.03	Average	Vertical
2	2390	32.51	-5.24	27.27	54	-26.73	Average	Vertical
3	2400	46.59	-5.29	41.3	54	-12.7	Average	Vertical
4	2402	54.34	-5.3	49.04	54	-4.96	Average	Vertical

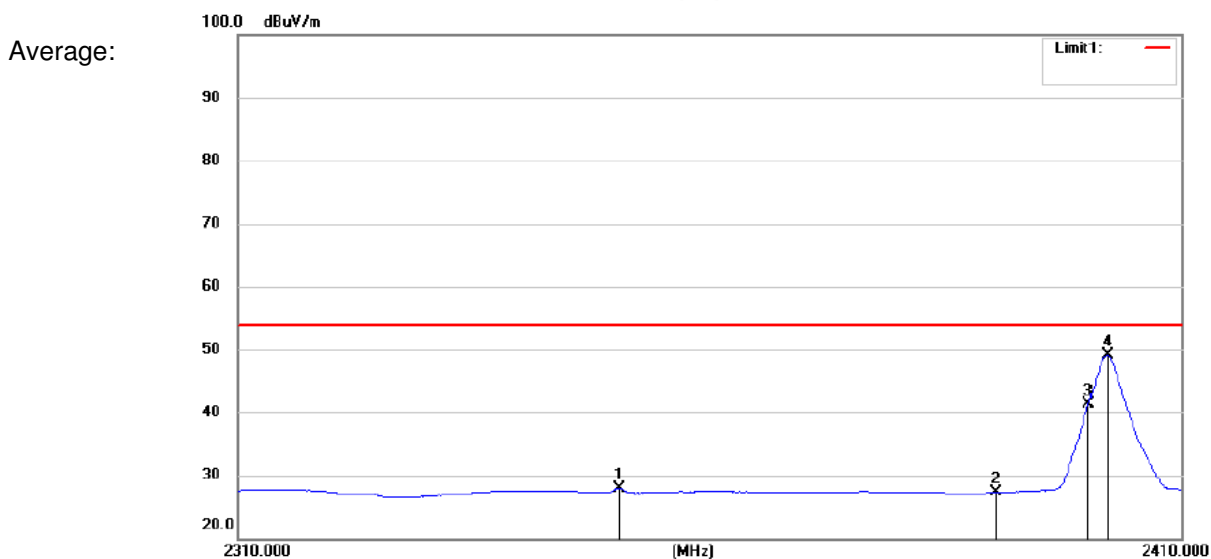
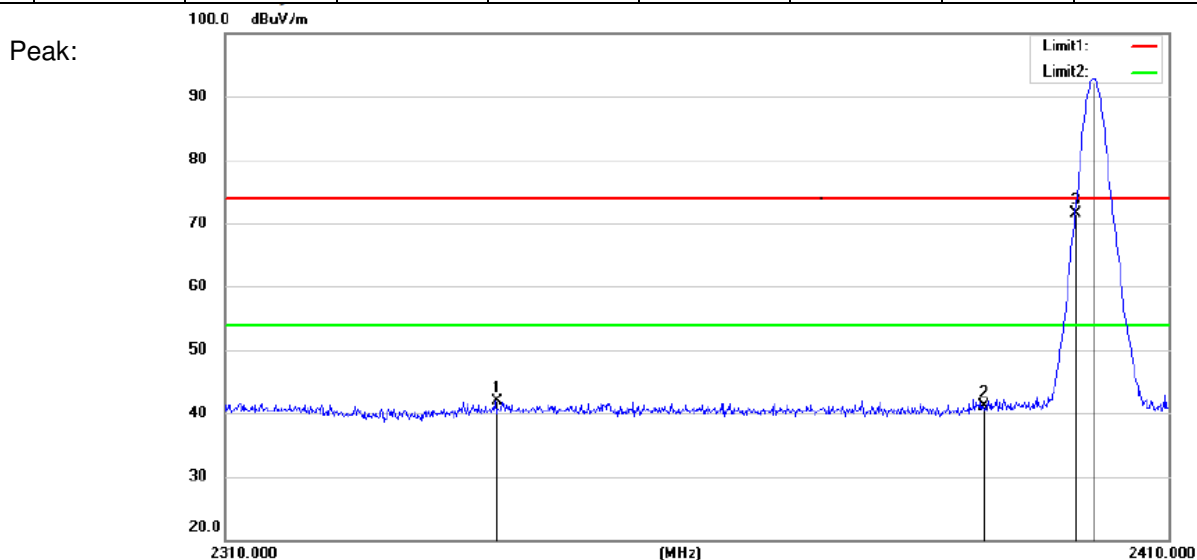

**Lowest Channel(2402MHz)**

**Modulation:  $\pi$ /4DQPSK**

MK.	Frequency (MHz)	Reading (dBuV/m)	Corrected factor(dB)	Result (dBuV/m)	Limit (dBuV/m)	Over Limit (dB)	Detector	Polarization
1	2341.2	46.41	-4.97	41.44	74	-32.56	Peak	Horizontal
2	2390	44.19	-5.24	38.95	74	-35.05	Peak	Horizontal
3	2400	75.05	-5.29	69.76	74	-4.24	Peak	Horizontal
4	2402	93.35	-5.3	88.05	74	14.05	Peak	Horizontal
1	2343.4	32.08	-4.97	27.11	54	-26.89	Average	Horizontal
2	2390	32.02	-5.24	26.78	54	-27.22	Average	Horizontal
3	2400	44.28	-5.29	38.99	54	-15.01	Average	Horizontal
4	2402	52.40	-5.3	47.1	54	-6.90	Average	Horizontal

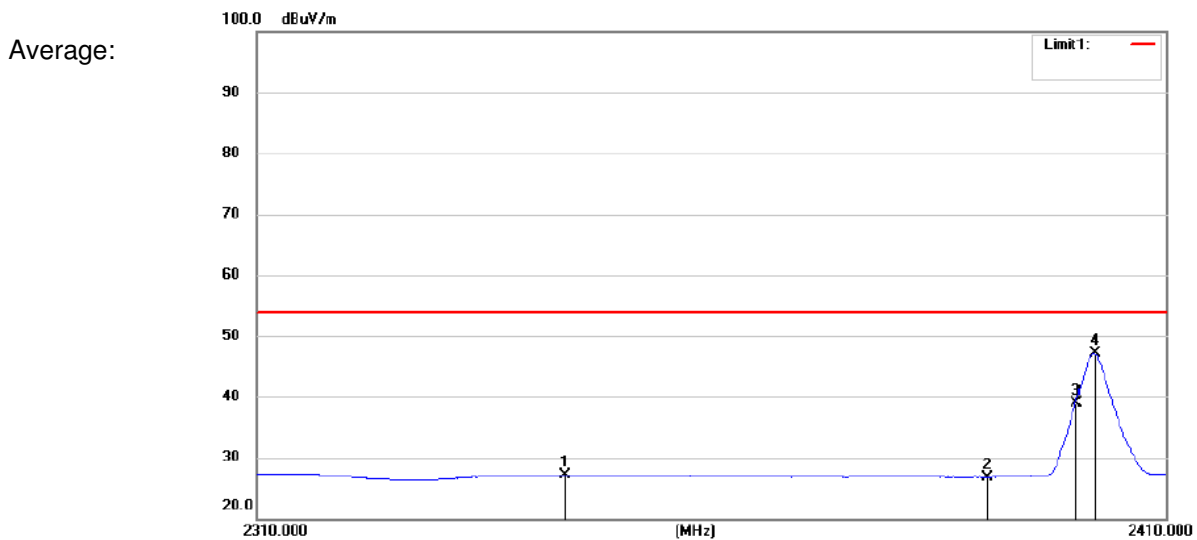
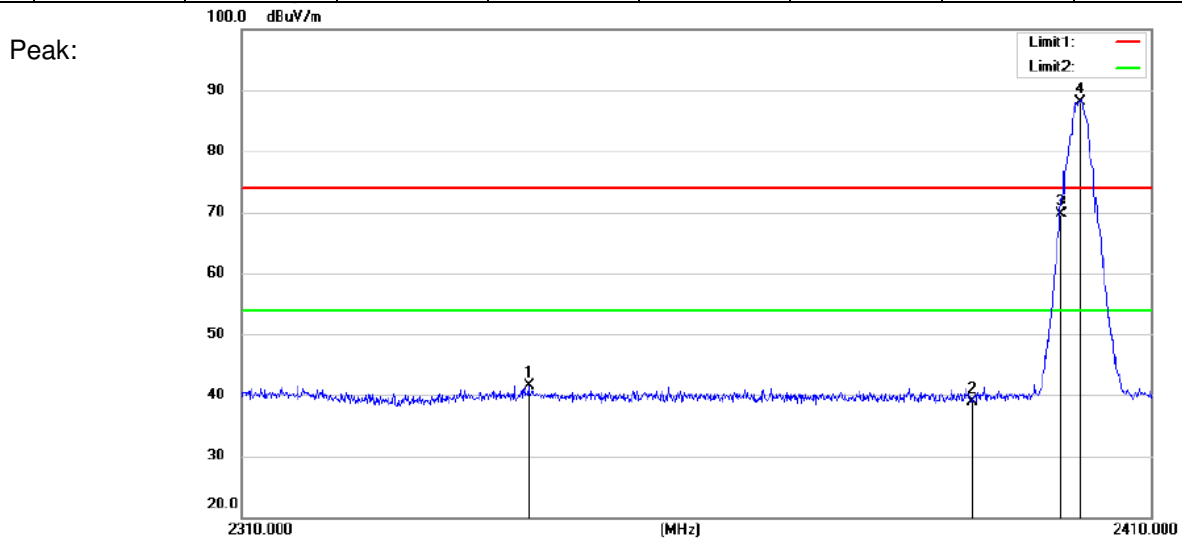

**Lowest Channel(2402MHz)**

**Modulation:  $\pi/4$ DQPSK**

MK.	Frequency (MHz)	Reading (dBuV/m)	Corrected factor(dB)	Result (dBuV/m)	Limit (dBuV/m)	Over Limit (dB)	Detector	Polarization
1	2341.1	47.2	-4.97	42.23	74	-31.77	Peak	Vertical
2	2390	46.54	-5.24	41.3	74	-32.7	Peak	Vertical
3	2400	77.61	-5.29	72.32	74	-1.68	Peak	Vertical
4	2402	95.95	-5.3	90.65	74	16.65	Peak	Vertical
1	2349.691	32.7	-5.02	27.68	54	-26.32	Average	Vertical
2	2390	32.68	-5.24	27.44	54	-26.56	Average	Vertical
3	2400	46.47	-5.29	41.18	54	-12.82	Average	Vertical
4	2402	53.98	-5.3	48.68	54	-5.32	Average	Vertical

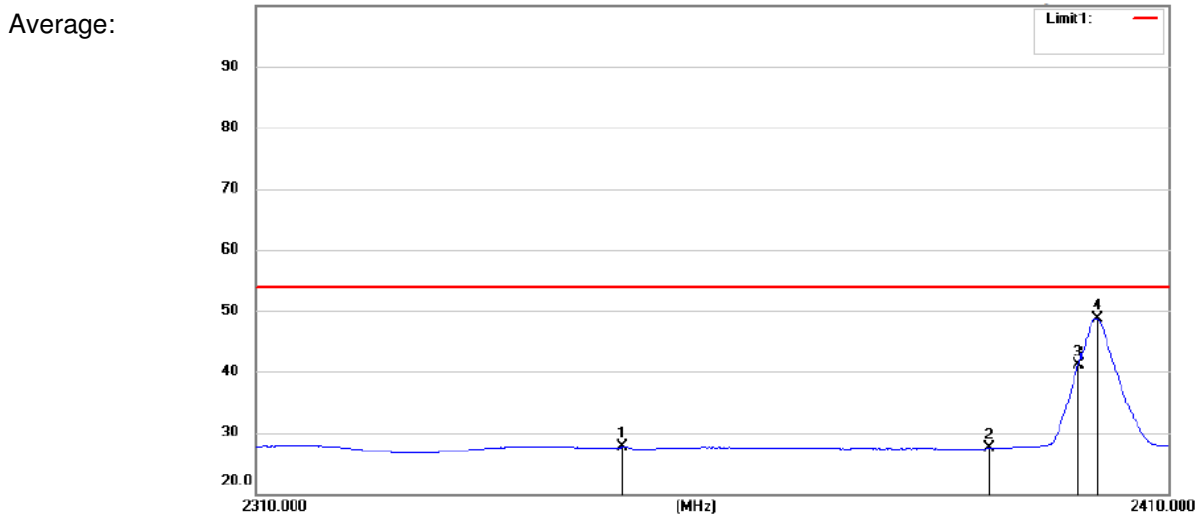
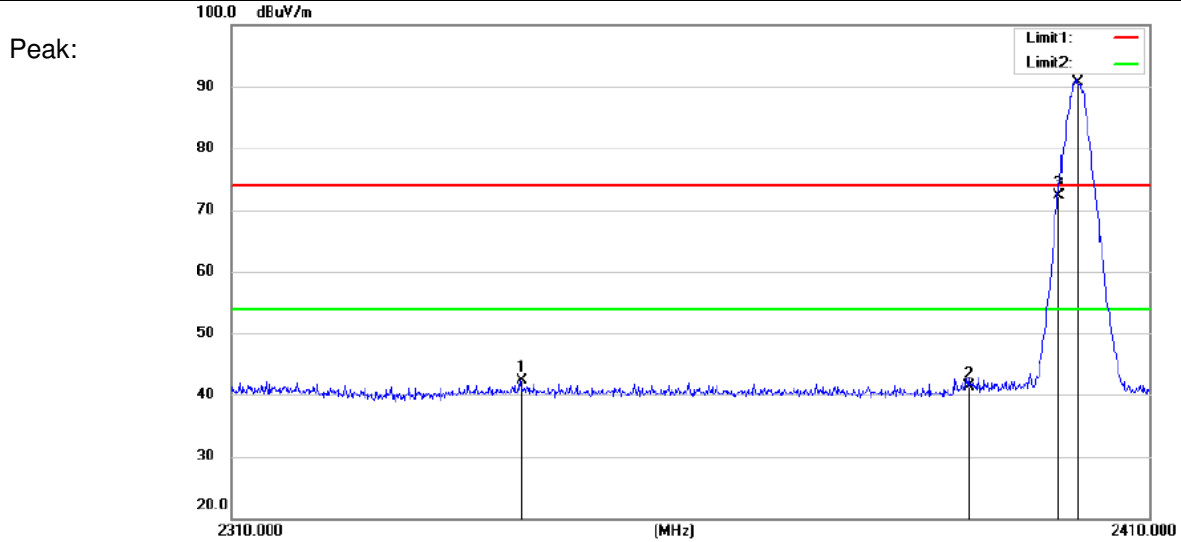

**Lowest Channel(2402MHz)**

**Modulation: 8DPSK**

MK.	Frequency (MHz)	Reading (dBuV/m)	Corrected factor(dB)	Result (dBuV/m)	Limit (dBuV/m)	Over Limit (dB)	Detector	Polarization
1	2341.9	46.28	-4.98	41.3	74	-32.7	Peak	Horizontal
2	2390	45.45	-5.24	40.21	74	-33.79	Peak	Horizontal
3	2400	75.49	-5.29	70.2	74	-3.8	Peak	Horizontal
4	2402	92.72	-5.3	87.42	74	13.42	Peak	Horizontal
1	2359.4	32.15	-5.06	27.09	54	-26.91	Average	Horizontal
2	2390	32.02	-5.24	26.78	54	-27.22	Average	Horizontal
3	2400	44.62	-5.29	39.33	54	-14.67	Average	Horizontal
4	2402	52.04	-5.3	46.74	54	-7.26	Average	Horizontal

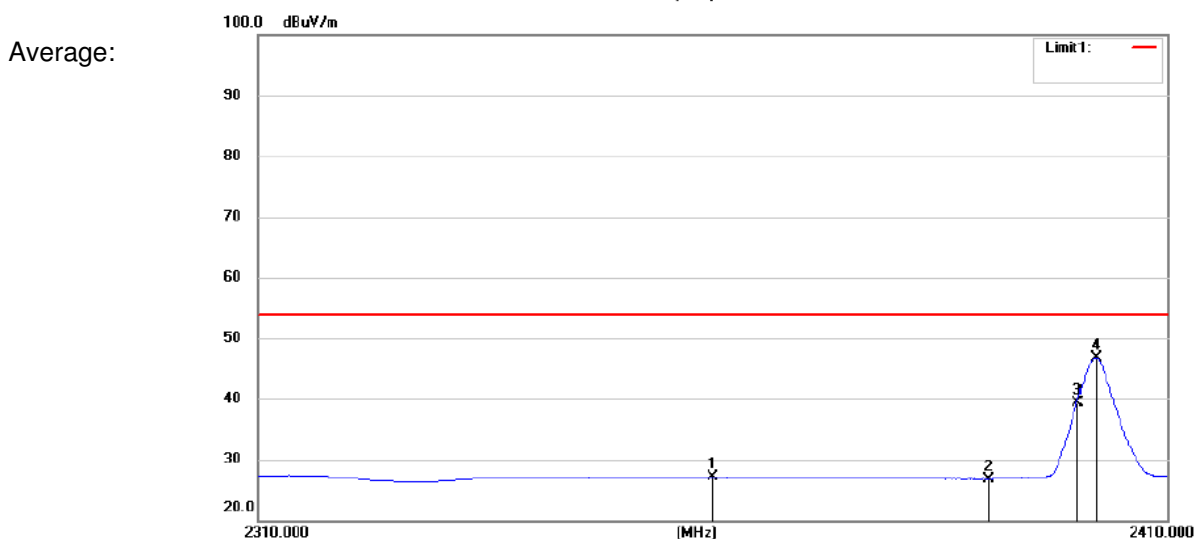
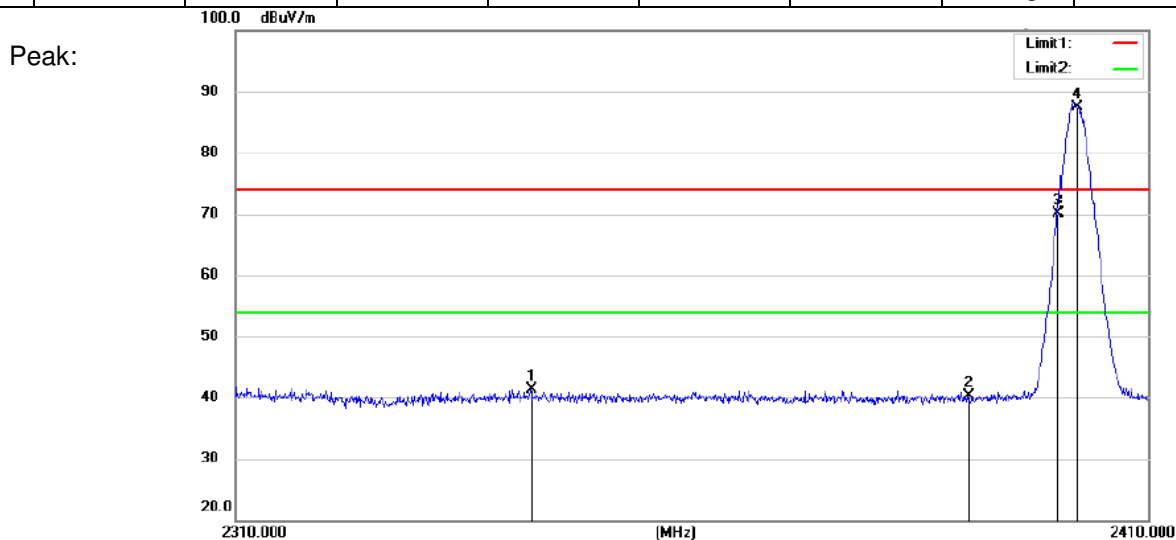

**Lowest Channel(2402MHz)**

**Modulation: 8DPSK**

MK.	Frequency (MHz)	Reading (dBuV/m)	Corrected factor(dB)	Result (dBuV/m)	Limit (dBuV/m)	Over Limit (dB)	Detector	Polarization
1	2350.8	47.99	-5.02	42.97	74	-31.03	Peak	Vertical
2	2390	46.29	-5.24	41.05	74	-32.95	Peak	Vertical
3	2400	77.94	-5.29	72.65	74	-1.35	Peak	Vertical
4	2402	96.56	-5.3	91.26	74	17.26	Peak	Vertical
1	2342.7	32.93	-4.97	27.96	54	-26.04	Average	Vertical
2	2390	32.83	-5.24	27.59	54	-26.41	Average	Vertical
3	2400	46.27	-5.29	40.98	54	-13.02	Average	Vertical
4	2402	54.4	-5.3	49.1	54	-4.9	Average	Vertical

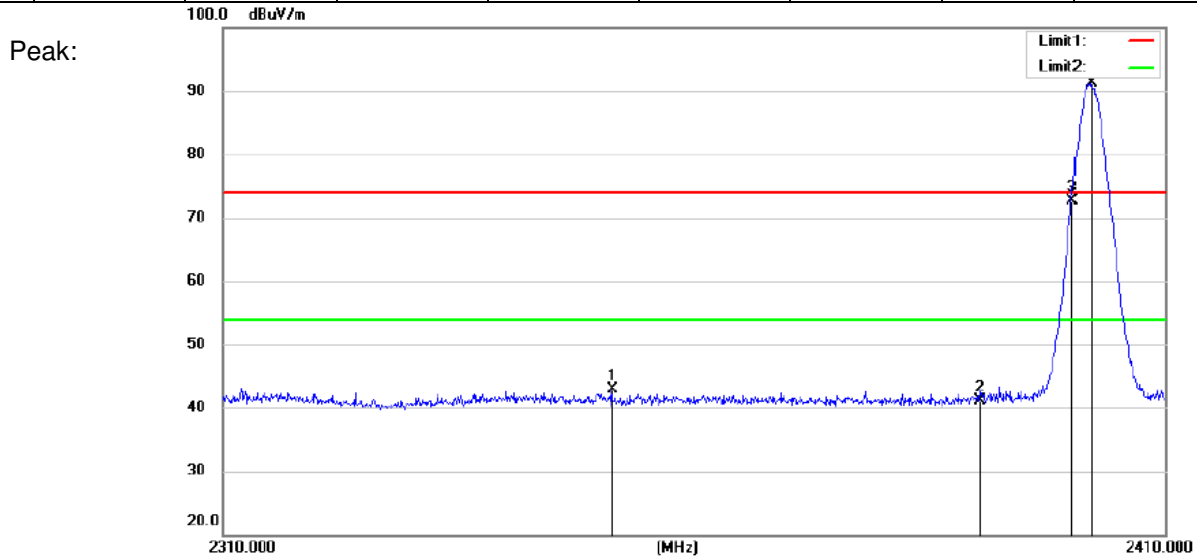

Average:

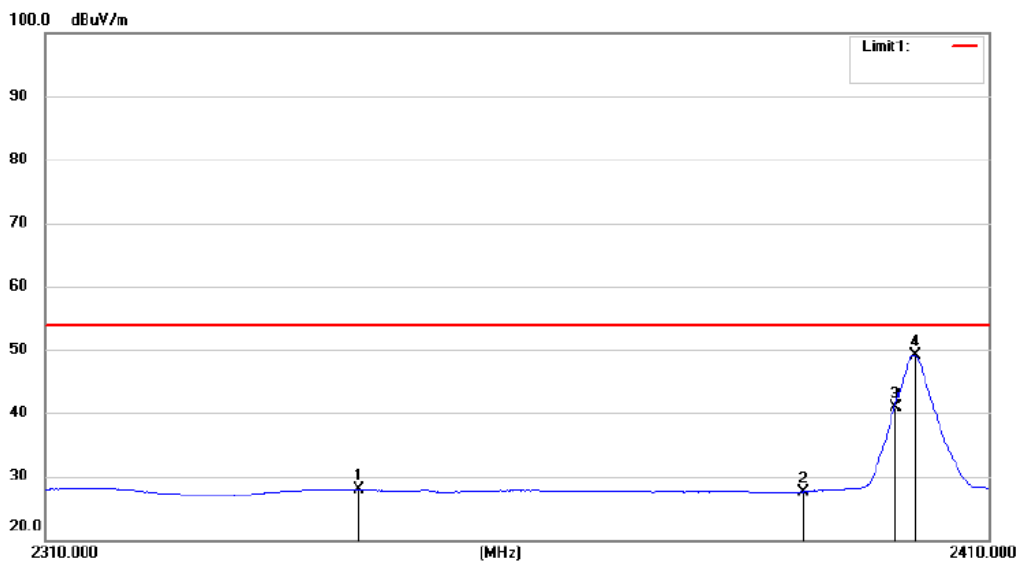



**CH Low 2480MHz**

**Modulation: GFSK**

MK.	Frequency (MHz)	Reading (dBuV/m)	Corrected factor(dB)	Result (dBuV/m)	Limit (dBuV/m)	Over Limit (dB)	Detector	Polarization
1	2480	95.47	-5.73	89.74	74	15.74	Peak	Horizontal
2	2483.5	56.81	-5.74	51.07	74	-22.93	Peak	Horizontal
3	2506.425	47	-5.77	41.23	74	-32.77	Peak	Horizontal
1	2480	53.46	-5.73	47.73	54	-6.27	Average	Horizontal
2	2483.5	39.32	-5.74	33.58	54	-20.42	Average	Horizontal
3	2531.925	33.48	-5.49	27.99	54	-26.01	Average	Horizontal

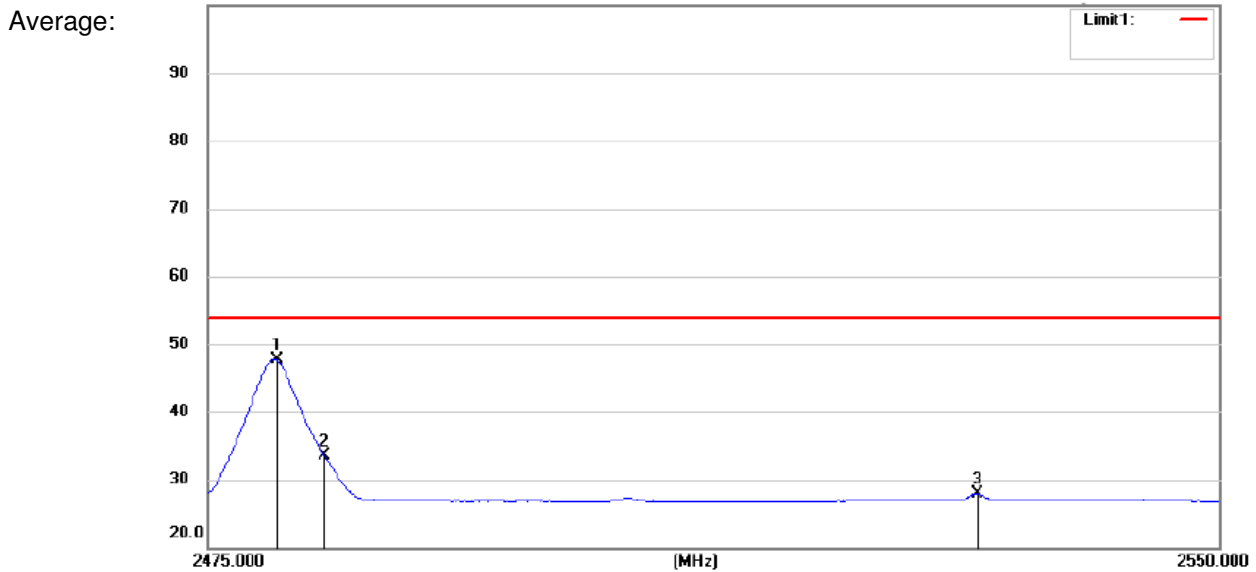
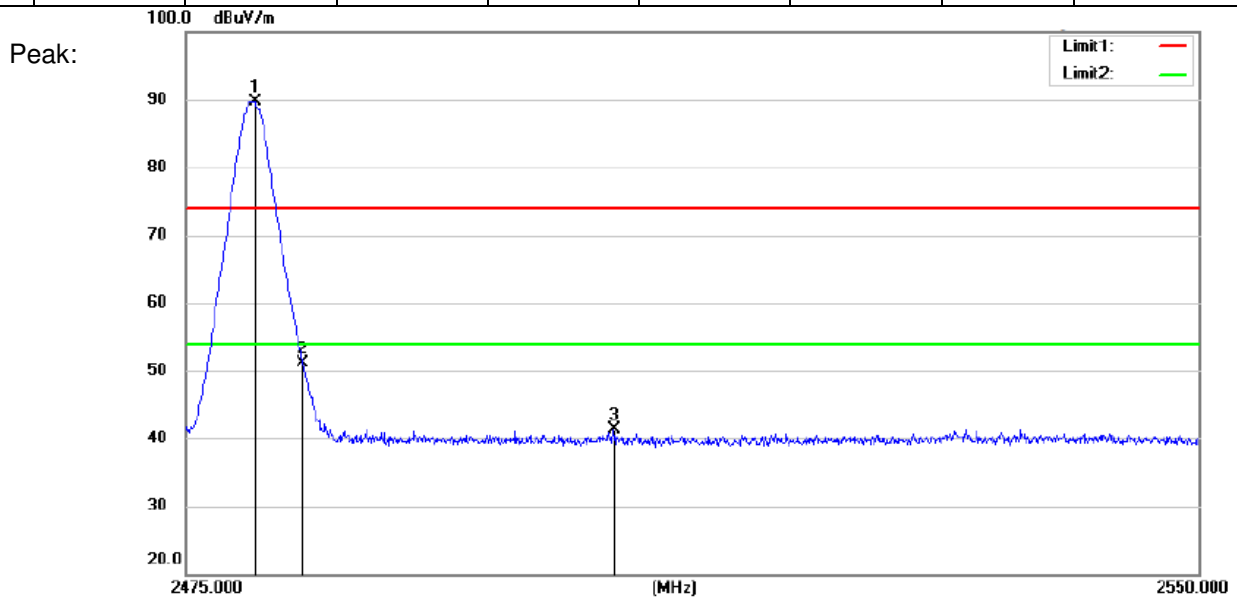

**CH Low 2480MHz**

**Modulation: GFSK**

MK.	Frequency (MHz)	Reading (dBuV/m)	Corrected factor(dB)	Result (dBuV/m)	Limit (dBuV/m)	Over Limit (dB)	Detector	Polarization
1	2480	93.62	-5.73	87.89	74	13.89	Peak	Vertical
2	2483.5	55.77	-5.74	50.03	74	-23.97	Peak	Vertical
3	2505	47.85	-5.78	42.07	74	-31.93	Peak	Vertical
1	2479.875	53.96	-5.73	48.23	54	-5.77	Average	Vertical
2	2483.5	39.8	-5.74	34.06	54	-19.94	Average	Vertical
3	2531.85	33.97	-5.49	28.48	54	-25.52	Average	Vertical

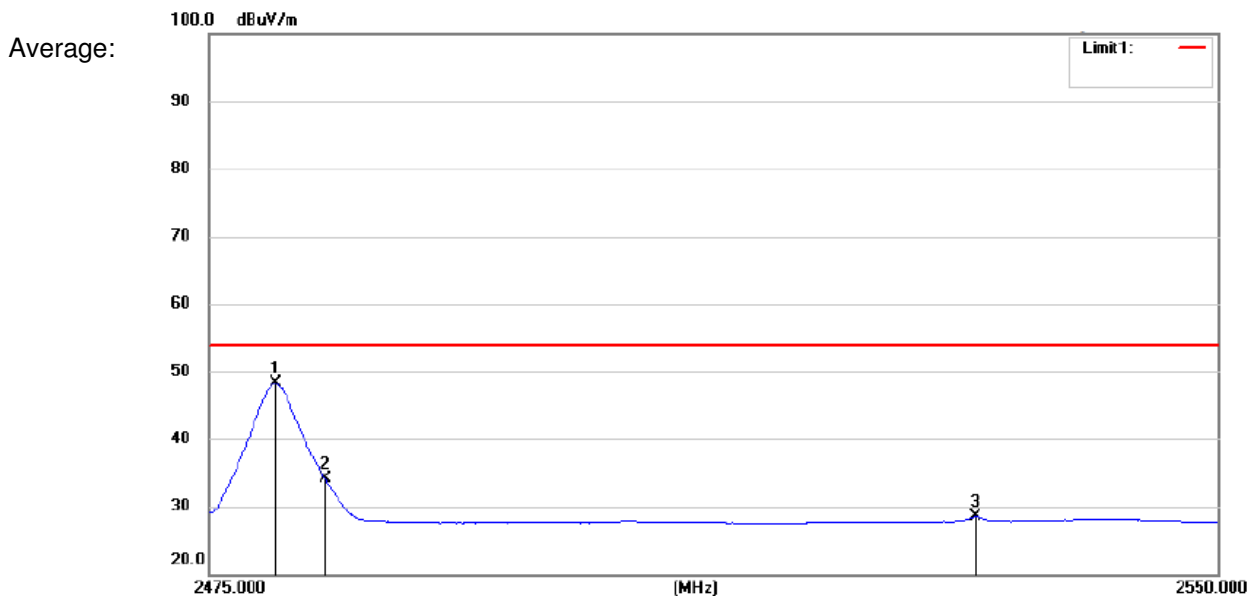
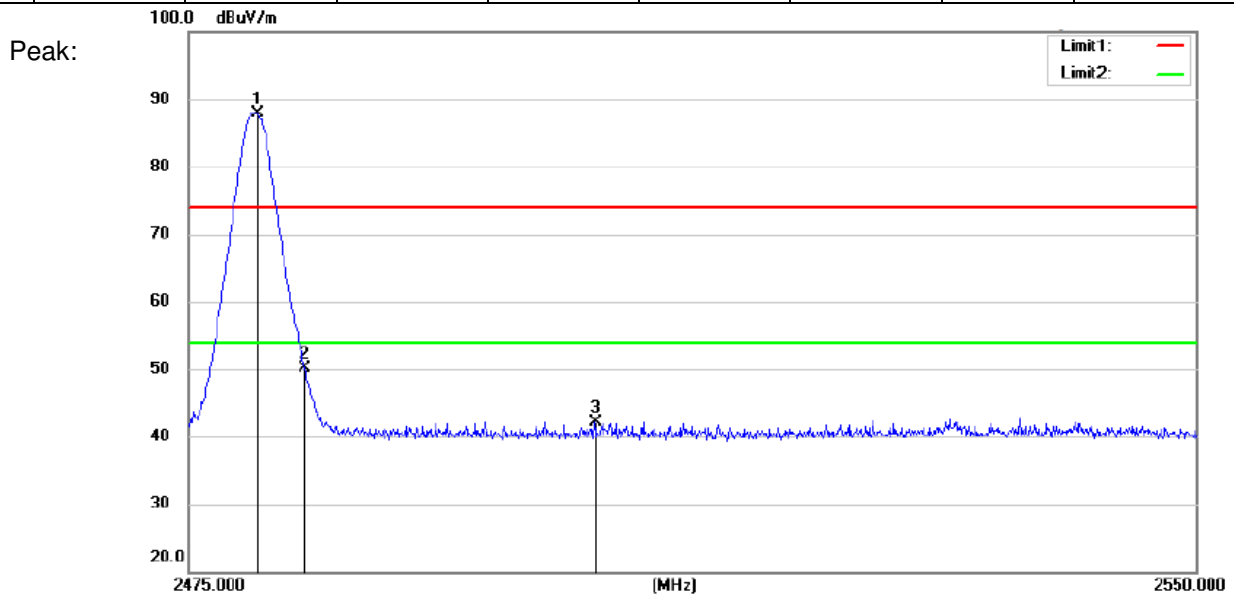

This document is issued by the Company subject to its General Conditions of Service printed overleaf, available on request or accessible at [www.sgs.com/terms\\_and\\_conditions.htm](http://www.sgs.com/terms_and_conditions.htm) and, for electronic format documents, subject to Terms and Conditions for Electronic Documents at [www.sgs.com/terms\\_e-document.htm](http://www.sgs.com/terms_e-document.htm). Attention is drawn to the limitation of liability, indemnification and jurisdiction issues defined therein. Any holder of this document is advised that information contained hereon reflects the Company's findings at the time of its intervention only and within the limits of Client's instructions, if any. The Company's sole responsibility is to its Client and this document does not exonerate parties to a transaction from exercising all their rights and obligations under the transaction documents. This document cannot be reproduced except in full, without prior written approval of the Company. Any unauthorized alteration, forgery or falsification of the content or appearance of this document is unlawful and offenders may be prosecuted to the fullest extent of the law. Unless otherwise stated the results shown in this test report refer only to the sample(s) tested and such sample(s) are retained for 90 days only

**CH Low 2480MHz**

**Modulation:  $\pi/4$ DQPSK**

MK.	Frequency (MHz)	Reading (dBuV/m)	Corrected factor(dB)	Result (dBuV/m)	Limit (dBuV/m)	Over Limit (dB)	Detector	Polarization
1	2480	95.11	-5.73	89.38	74	15.38	Peak	Horizontal
2	2483.5	62.2	-5.74	56.46	74	-17.54	Peak	Horizontal
3	2531.925	47.34	-5.49	41.85	74	-32.15	Peak	Horizontal
1	2480	53.97	-5.73	48.24	54	-5.76	Average	Horizontal
2	2483.5	39.29	-5.74	33.55	54	-20.45	Average	Horizontal
3	2531.85	33.51	-5.49	28.02	54	-25.98	Average	Horizontal

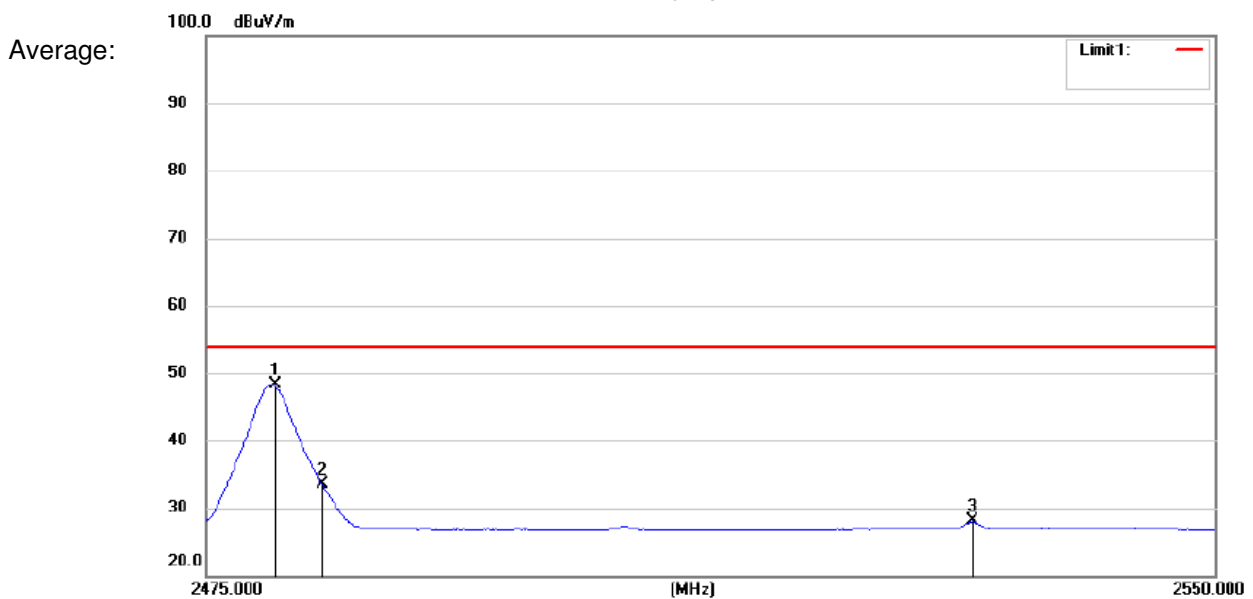
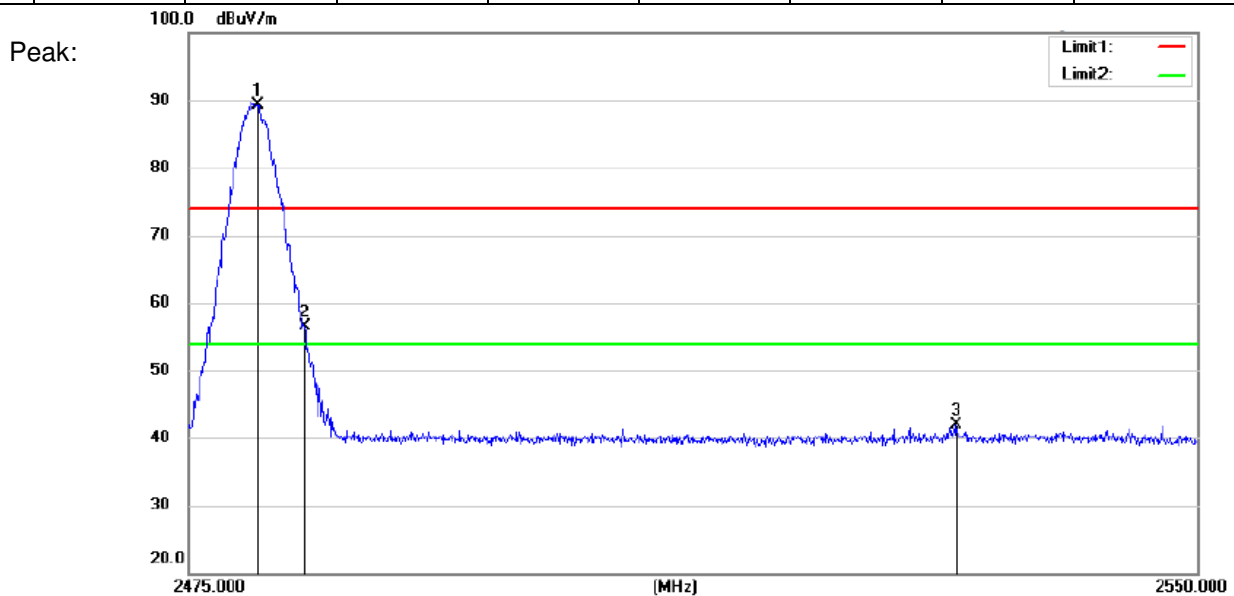

This document is issued by the Company subject to its General Conditions of Service printed overleaf, available on request or accessible at [www.sgs.com/terms\\_and\\_conditions.htm](http://www.sgs.com/terms_and_conditions.htm) and, for electronic format documents, subject to Terms and Conditions for Electronic Documents at [www.sgs.com/terms\\_e-document.htm](http://www.sgs.com/terms_e-document.htm). Attention is drawn to the limitation of liability, indemnification and jurisdiction issues defined therein. Any holder of this document is advised that information contained hereon reflects the Company's findings at the time of its intervention only and within the limits of Client's instructions, if any. The Company's sole responsibility is to its Client and this document does not exonerate parties to a transaction from exercising all their rights and obligations under the transaction documents. This document cannot be reproduced except in full, without prior written approval of the Company. Any unauthorized alteration, forgery or falsification of the content or appearance of this document is unlawful and offenders may be prosecuted to the fullest extent of the law. Unless otherwise stated the results shown in this test report refer only to the sample(s) tested and such sample(s) are retained for 90 days only

**CH Low 2480MHz**

**Modulation:  $\pi/4$ DQPSK**

MK.	Frequency (MHz)	Reading (dBuV/m)	Corrected factor(dB)	Result (dBuV/m)	Limit (dBuV/m)	Over Limit (dB)	Detector	Polarization
1	2480	93.89	-5.73	88.16	74	14.16	Peak	Vertical
2	2483.5	61	-5.74	55.26	74	-18.74	Peak	Vertical
3	2494.275	47.85	-5.81	42.04	74	-31.96	Peak	Vertical
1	2480	54.39	-5.73	48.66	54	-5.34	Average	Vertical
2	2483.5	39.77	-5.74	34.03	54	-19.97	Average	Vertical
3	2531.925	33.94	-5.49	28.45	54	-25.55	Average	Vertical

Peak:

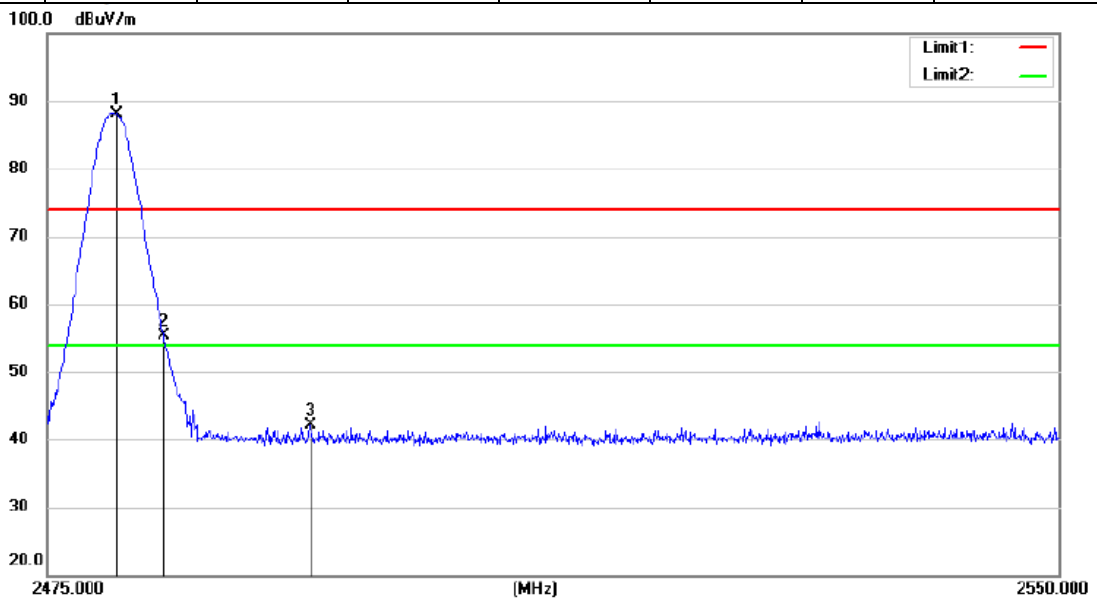

Average:

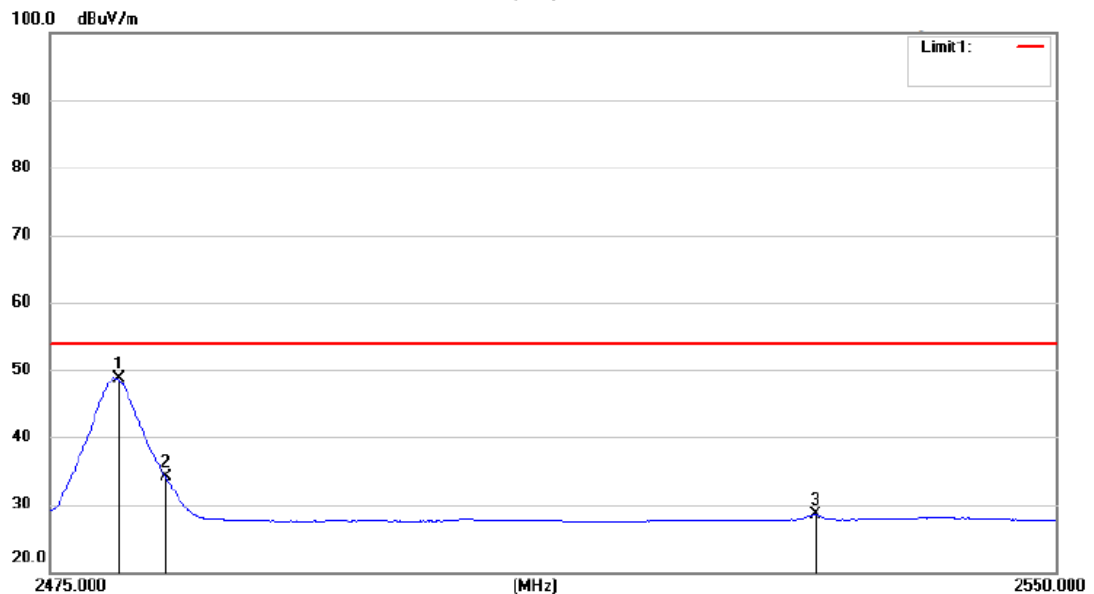

**CH Low 2480MHz**

**Modulation: 8DPSK**

MK.	Frequency (MHz)	Reading (dBuV/m)	Corrected factor(dB)	Result (dBuV/m)	Limit (dBuV/m)	Over Limit (dB)	Detector	Polarization
1	2480	94.29	-5.73	88.56	74	14.56	Peak	Horizontal
2	2483.5	61.7	-5.74	55.96	74	-18.04	Peak	Horizontal
3	2531.775	46.52	-5.49	41.03	74	-32.97	Peak	Horizontal
1	2480	53.57	-5.73	47.84	54	-6.16	Average	Horizontal
2	2483.5	39.48	-5.74	33.74	54	-20.26	Average	Horizontal
3	2531.925	33.31	-5.49	27.82	54	-26.18	Average	Horizontal

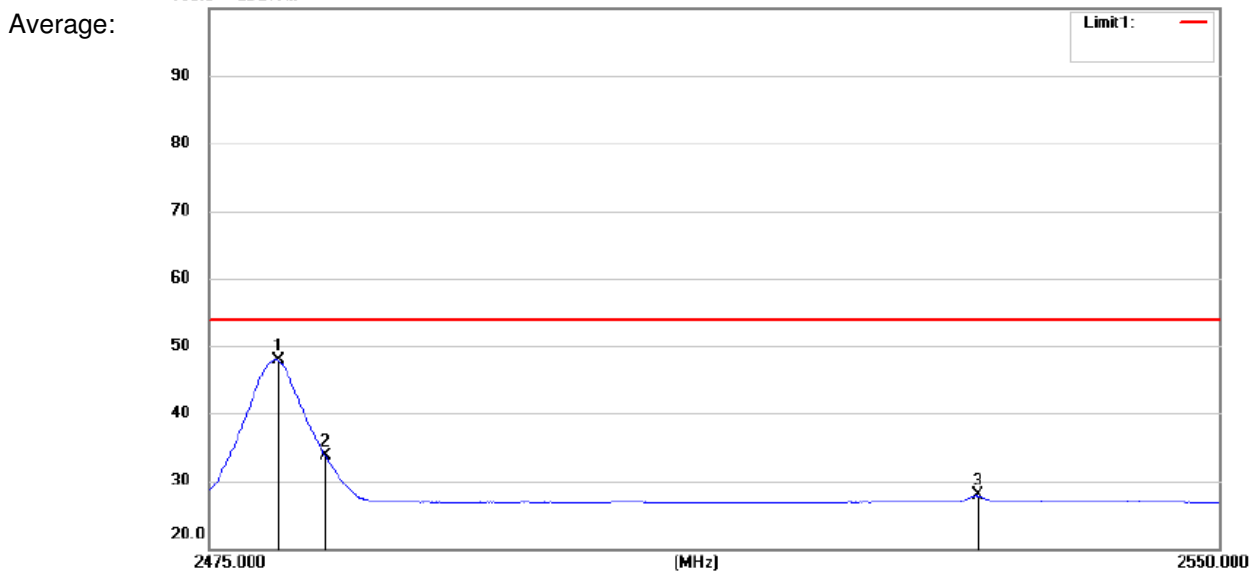
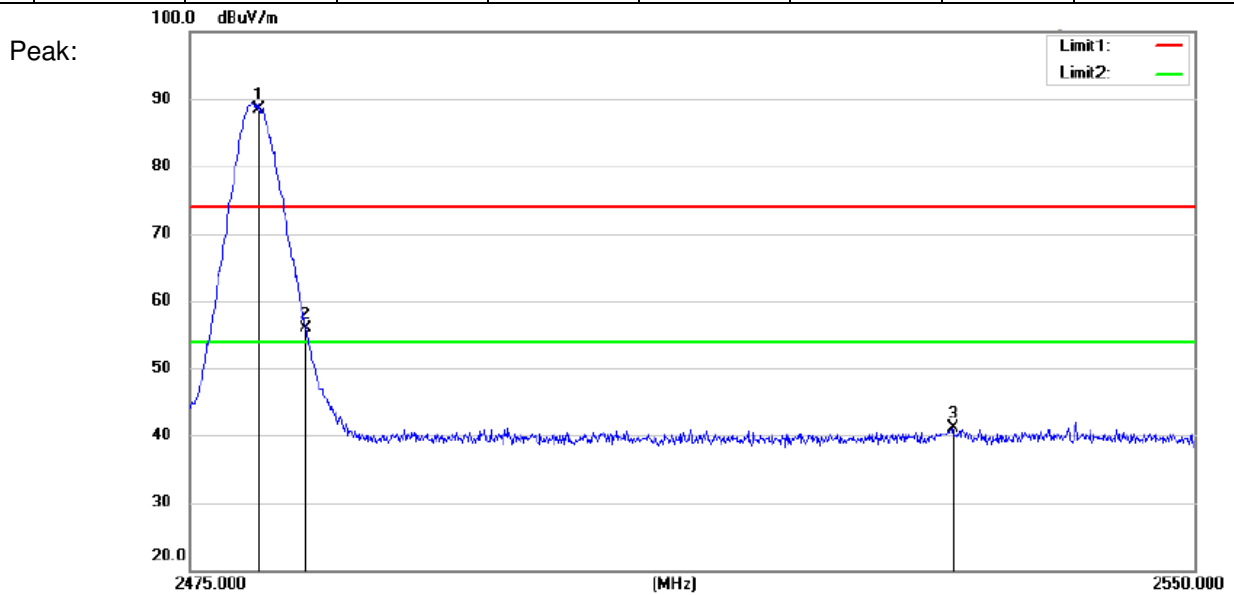

**CH Low 2480MHz**

**Modulation: 8DPSK**

MK.	Frequency (MHz)	Reading (dBuV/m)	Corrected factor(dB)	Result (dBuV/m)	Limit (dBuV/m)	Over Limit (dB)	Detector	Polarization
1	2480	93.74	-5.73	88.01	74	14.01	Peak	Vertical
2	2483.5	60.1	-5.74	54.36	74	-19.64	Peak	Vertical
3	2508.675	47.98	-5.74	42.24	74	-31.76	Peak	Vertical
1	2480	54.12	-5.73	48.39	54	-5.61	Average	Vertical
2	2483.5	39.72	-5.74	33.98	54	-20.02	Average	Vertical
3	2505.825	33.61	-5.77	27.84	54	-26.16	Average	Vertical

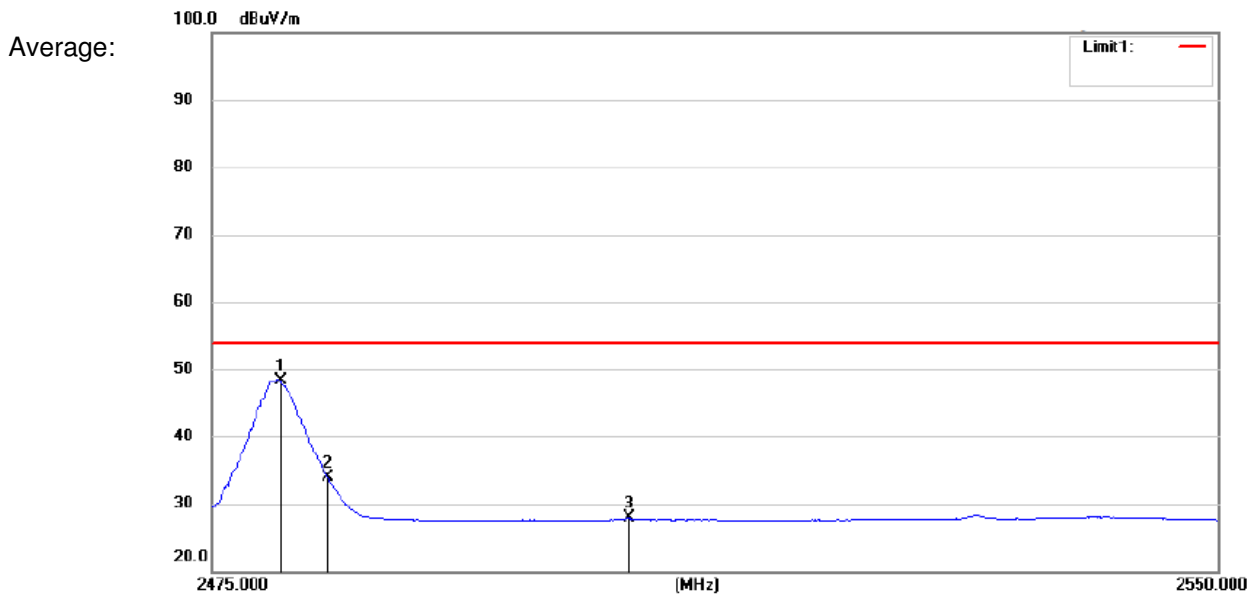
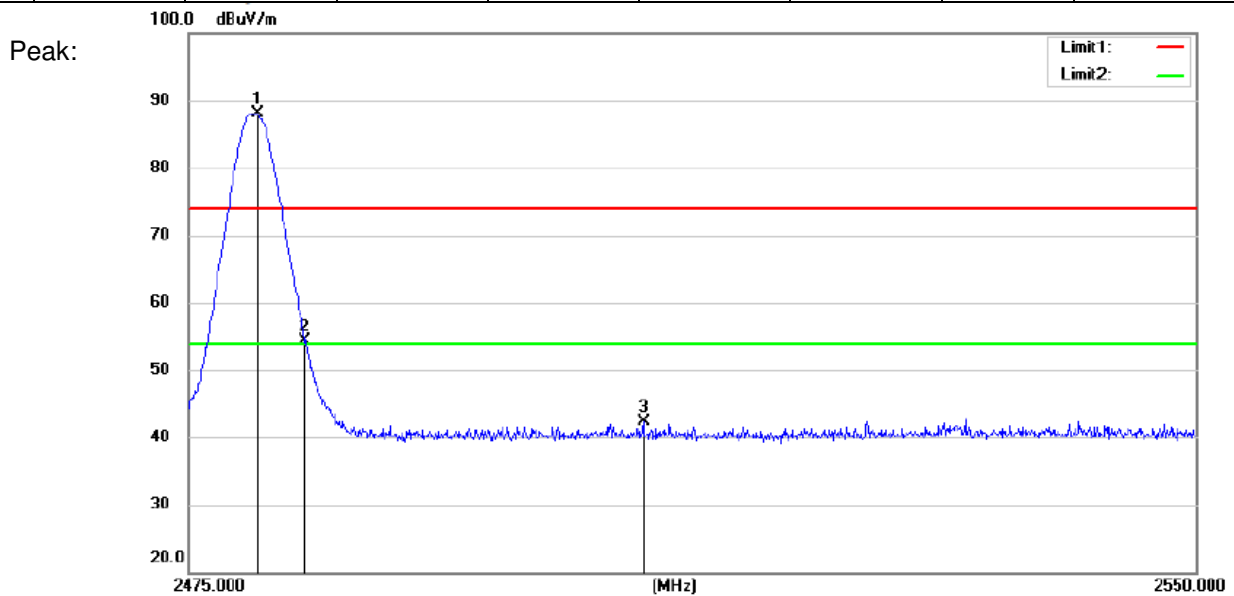

This document is issued by the Company subject to its General Conditions of Service printed overleaf, available on request or accessible at [www.sgs.com/terms\\_and\\_conditions.htm](http://www.sgs.com/terms_and_conditions.htm) and, for electronic format documents, subject to Terms and Conditions for Electronic Documents at [www.sgs.com/terms\\_e-document.htm](http://www.sgs.com/terms_e-document.htm). Attention is drawn to the limitation of liability, indemnification and jurisdiction issues defined therein. Any holder of this document is advised that information contained hereon reflects the Company's findings at the time of its intervention only and within the limits of Client's instructions, if any. The Company's sole responsibility is to its Client and this document does not exonerate parties to a transaction from exercising all their rights and obligations under the transaction documents. This document cannot be reproduced except in full, without prior written approval of the Company. Any unauthorized alteration, forgery or falsification of the content or appearance of this document is unlawful and offenders may be prosecuted to the fullest extent of the law. Unless otherwise stated the results shown in this test report refer only to the sample(s) tested and such sample(s) are retained for 90 days only

- Remark: 1. Test Level =Receiver Reading + Antenna Factor + Cable Loss –Preamplifier Factor.
2. No any other emissions level which are attenuated less than 20dB below the limit. According to 15.31(o), the amplitude of spurious emissions from intentional radiators and emissions from unintentional radiators which are attenuated more than 20 dB below the permissible value need not be reported unless specifically required elsewhere in this Part. Hence there no other emissions have been reported.
3. If the Peak value below the AV Limit, the AV test doesn't perform for this submission.

All frequencies within the “Restricted bands” have been evaluated to compliance.  
Except as shown in paragraph of this section, only spurious emissions are permitted in any of the frequency bands listed below:

1. FCC Part 15, Subpart C Section 15.205 Restricted bands of operation.

MHz	MHz	MHz	GHz
0.090 - 0.110	16.42 - 16.423	399.9 - 410	4.5 - 5.15
<sup>1</sup> 0.495 - 0.505	16.69475 - 16.69525	608 - 614	5.35 - 5.46
2.1735 - 2.1905	16.80425 - 16.80475	960 - 1240	7.25 - 7.75
4.125 - 4.128	25.5 - 25.67	1300 - 1427	8.025 - 8.5
4.17725 - 4.17775	37.5 - 38.25	1435 - 1626.5	9.0 - 9.2
4.20725 - 4.20775	73 - 74.6	1645.5 - 1646.5	9.3 - 9.5
6.215 - 6.218	74.8 - 75.2	1660 - 1710	10.5 - 12.7
6.26775 - 6.26825	108 - 121.94	1718.8 - 1722.2	13.25 - 13.4
6.31175 - 6.31225	123 - 138	2200 - 2300	14.47 - 14.5
8.291 - 8.294	149.9 - 150.05	2310 - 2390	15.35 - 16.2
8.362 - 8.366	156.52475 - 156.52525	2483.5 - 2500	17.7 - 21.4
8.37625 - 8.38675	156.7 - 156.9	2655 - 2900	22.01 - 23.12
8.41425 - 8.41475	162.0125 - 167.17	3260 - 3267	23.6 - 24.0
12.29 - 12.293	167.72 - 173.2	3332 - 3339	31.2 - 31.8
12.51975 - 12.52025	240 - 285	3345.8 - 3358	36.43 - 36.5
12.57675 - 12.57725	322 - 335.4	3600 - 4400	
13.36 - 13.41			



2. RSS-Gen section 7.2.2 Restricted bands of operation

MHz	MHz	GHz
0.090-0.110	240-285	9.0-9.2
2.1735-2.1905	322-335.4	9.3-9.5
3.020-3.026	399.9-410	10.6-12.7
4.125-4.128	608-614	13.25-13.4
4.17725-4.17775	960-1427	14.47-14.5
4.20725-4.20775	1435-1626.5	15.35-16.2
5.677-5.683	1645.5-1646.5	17.7-21.4
6.215-6.218	1660-1710	22.01-23.12
6.26775-6.26825	1718.8-1722.2	23.6-24.0
6.31175-6.31225	2200-2300	31.2-31.8
8.291-8.294	2310-2390	36.43-36.5
8.362-8.366	2655-2900	Above 38.6
8.37625-8.38675	3260-3267	
8.41425-8.41475	3332-3339	
12.29-12.293	3345.8-3358	
12.51975-12.52025	3500-4400	
12.57675-12.57725	4500-5150	
13.36-13.41	5350-5460	
16.42-16.423	7250-7750	
16.69475-16.69525	8025-8500	
16.80425-16.80475		
25.5-25.67		
37.5-38.25		
73-74.6		
74.8-75.2		
108-138		
156.52475-156.52525		
156.7-156.9		



### 7.12 Occupied Bandwidth Test

**Test Configuration:**

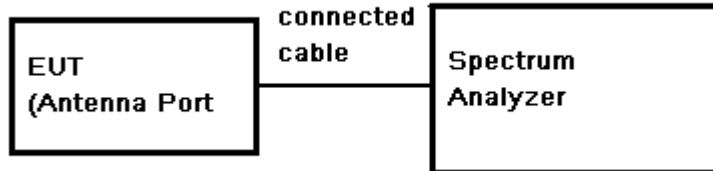

**Test Procedure:**

1. Remove the antenna from the EUT and then connect a low RF cable from the antenna port to the spectrum;
2. Set the spectrum analyzer: Span = approximately 2 to 3 times the 20dB bandwidth, centred on the hopping channel;
3. Set the spectrum analyzer: RBW  $\geq$  1% of the selected span (set 30 kHz). VBW  $\geq$  RBW. Sweep = auto; Detector Function = Peak. Trace = Max Hold.
4. Mark the peak frequency and 99% bandwidth points.

**Test Result:**

Pass

**Test Data:**

Test Mode	Channel	Frequency (MHz)	Bandwidth (MHz)
GFSK	LOW	2402	0.996
	MID	2441	0.993
	HIGH	2480	0.993
$\pi/4$ DQPSK	LOW	2402	1.092
	MID	2441	1.098
	HIGH	2480	1.128
8DPSK	LOW	2402	1.122
	MID	2441	1.128
	HIGH	2480	1.146

**Test plot as follows:**

Test mode:	GFSK	Test channel:	Lowest
------------	------	---------------	--------

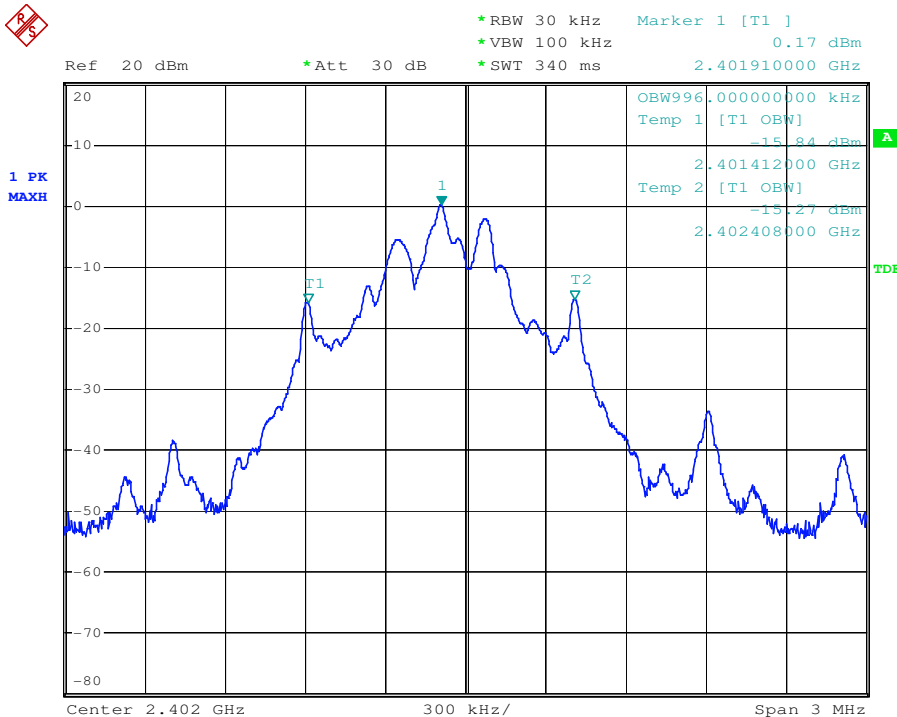

Test mode:	GFSK	Test channel:	Middle
------------	------	---------------	--------

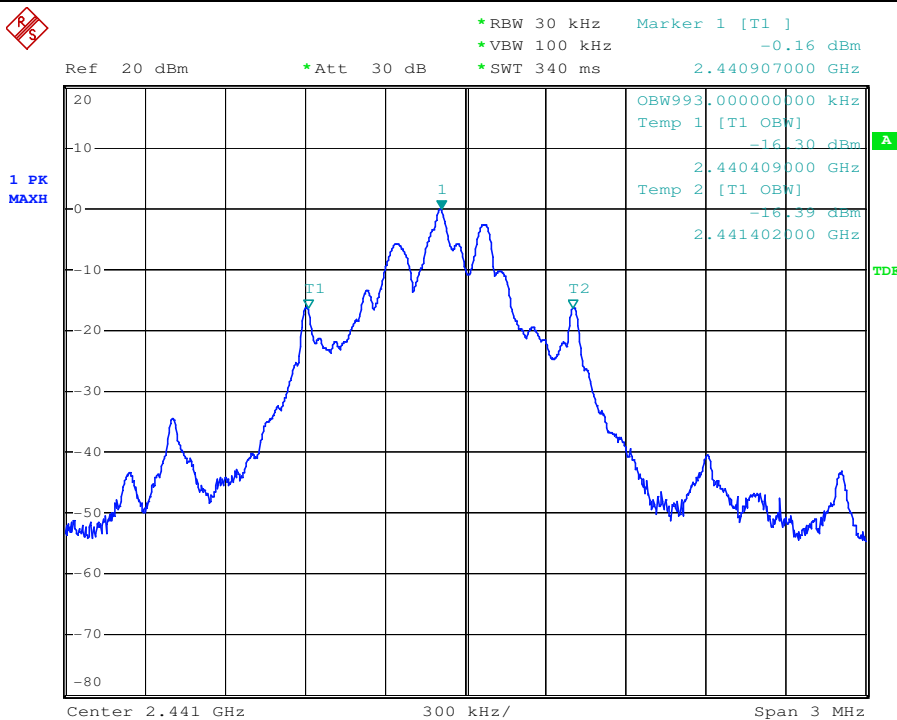

Test mode:	GFSK	Test channel:	Highest
------------	------	---------------	---------

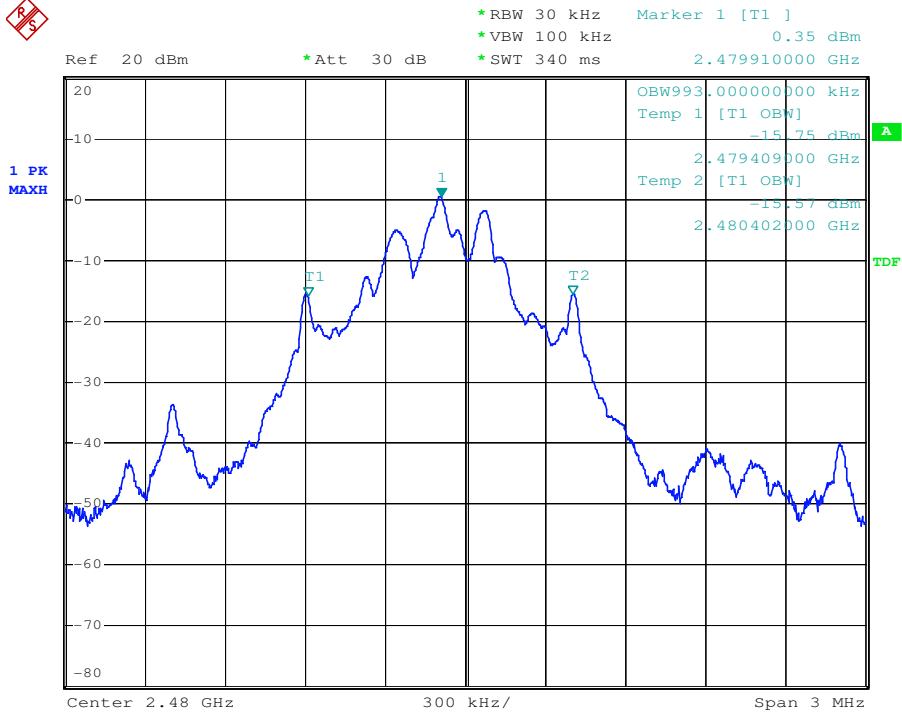

Test mode:	$\pi/4$ DQPSK	Test channel:	Low
------------	---------------	---------------	-----

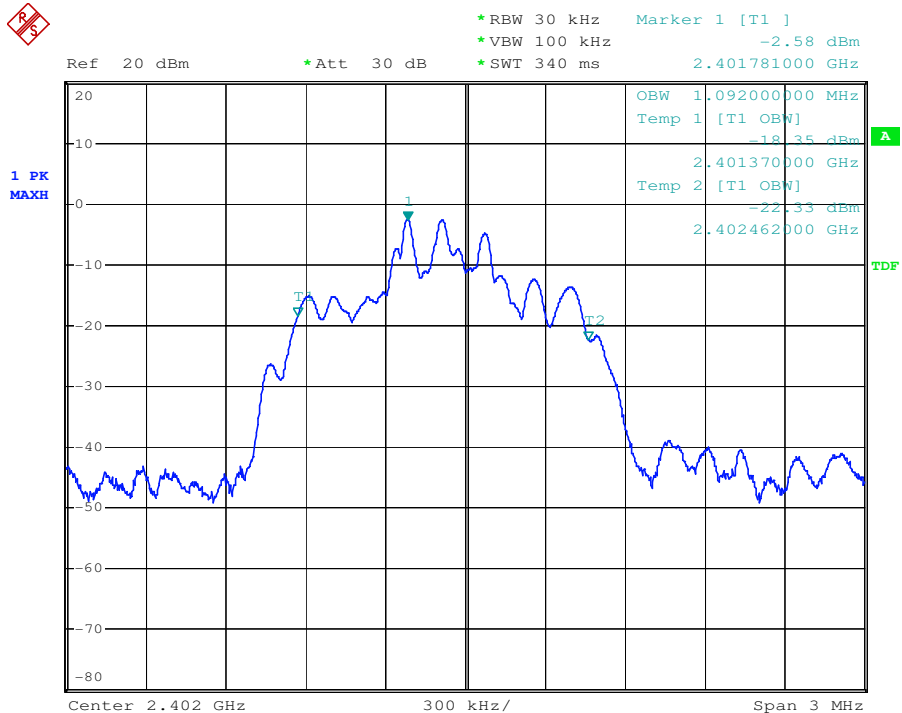

This document is issued by the Company subject to its General Conditions of Service printed overleaf, available on request or accessible at [www.sgs.com/terms\\_and\\_conditions.htm](http://www.sgs.com/terms_and_conditions.htm) and, for electronic format documents, subject to Terms and Conditions for Electronic Documents at [www.sgs.com/terms\\_e-document.htm](http://www.sgs.com/terms_e-document.htm). Attention is drawn to the limitation of liability, indemnification and jurisdiction issues defined therein. Any holder of this document is advised that information contained hereon reflects the Company's findings at the time of its intervention only and within the limits of Client's instructions, if any. The Company's sole responsibility is to its Client and this document does not exonerate parties to a transaction from exercising all their rights and obligations under the transaction documents. This document cannot be reproduced except in full, without prior written approval of the Company. Any unauthorized alteration, forgery or falsification of the content or appearance of this document is unlawful and offenders may be prosecuted to the fullest extent of the law. Unless otherwise stated the results shown in this test report refer only to the sample(s) tested and such sample(s) are retained for 90 days only.

Test mode:	$\pi/4$ DQPSK	Test channel:	Middle
------------	---------------	---------------	--------

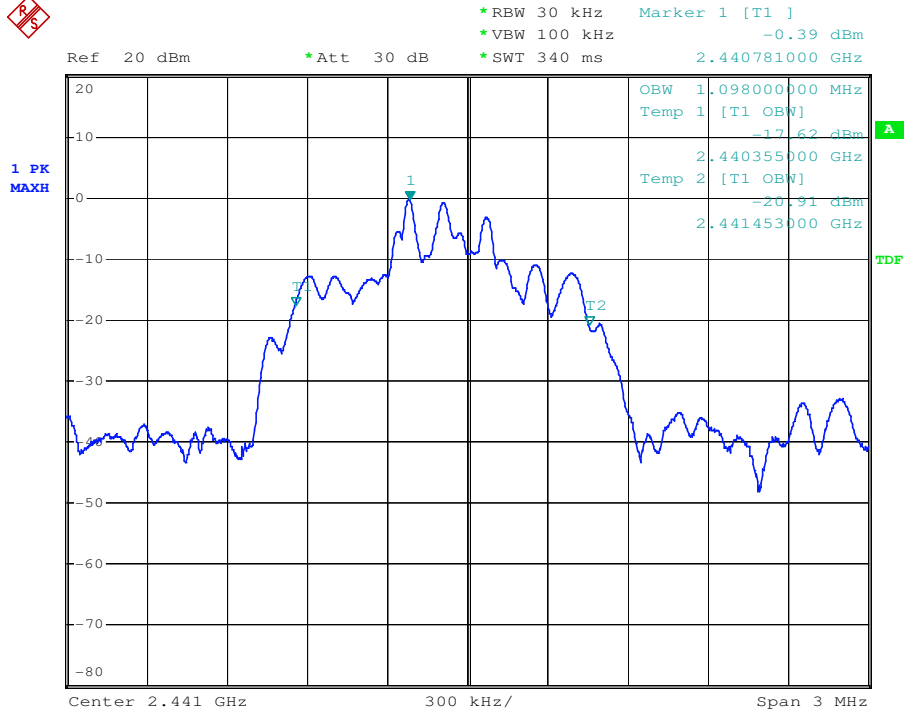

Test mode:	$\pi/4$ DQPSK	Test channel:	Highest
------------	---------------	---------------	---------

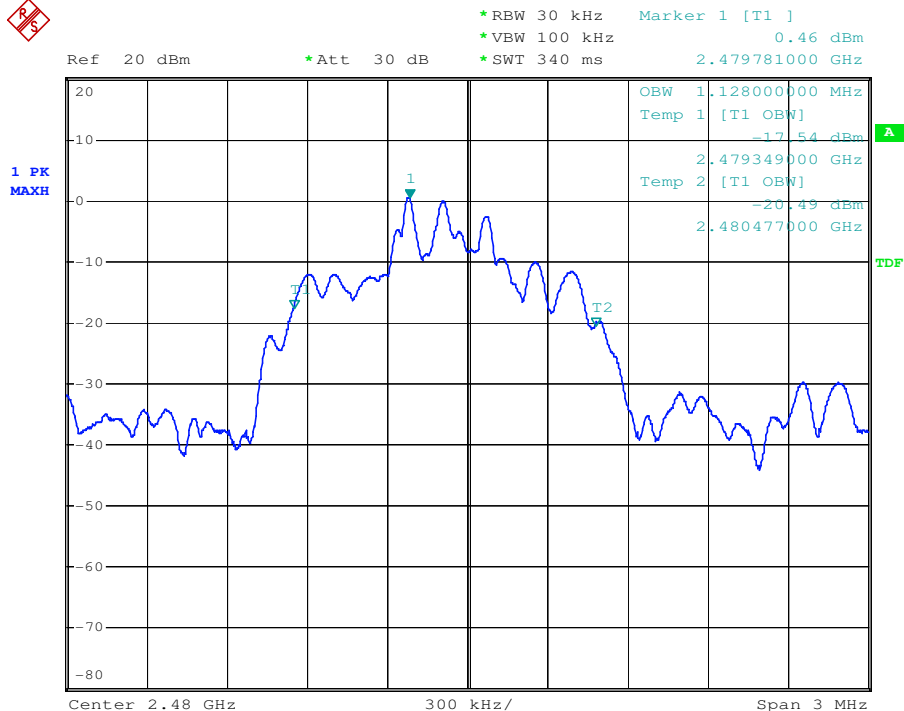

This document is issued by the Company subject to its General Conditions of Service printed overleaf, available on request or accessible at [www.sgs.com/terms\\_and\\_conditions.htm](http://www.sgs.com/terms_and_conditions.htm) and, for electronic format documents, subject to Terms and Conditions for Electronic Documents at [www.sgs.com/terms\\_e-document.htm](http://www.sgs.com/terms_e-document.htm). Attention is drawn to the limitation of liability, indemnification and jurisdiction issues defined therein. Any holder of this document is advised that information contained herein reflects the Company's findings at the time of its intervention only and within the limits of Client's instructions, if any. The Company's sole responsibility is to its Client and this document does not exonerate parties to a transaction from exercising all their rights and obligations under the transaction documents. This document cannot be reproduced except in full, without prior written approval of the Company. Any unauthorized alteration, forgery or falsification of the content or appearance of this document is unlawful and offenders may be prosecuted to the fullest extent of the law. Unless otherwise stated the results shown in this test report refer only to the sample(s) tested and such sample(s) are retained for 90 days only

Test mode:	8DPSK	Test channel:	Low
------------	-------	---------------	-----



\*RBW 30 kHz      Marker 1 [T1 ]  
 \*VBW 100 kHz      -2.76 dBm  
 Ref 20 dBm      \*Att 30 dB      \*SWT 340 ms      2.401913000 GHz

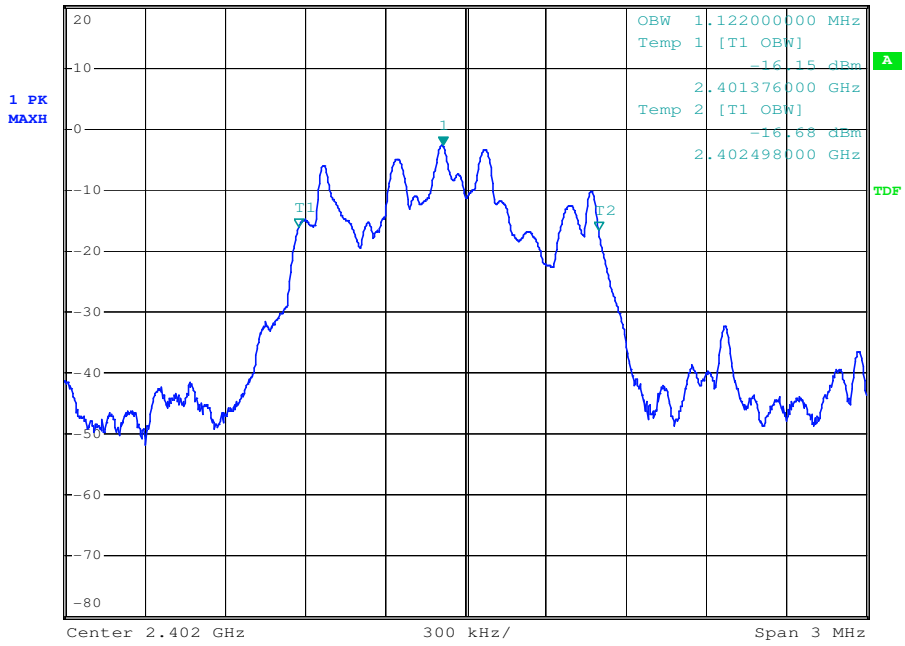

Test mode:	8DPSK	Test channel:	Middle
------------	-------	---------------	--------



\*RBW 30 kHz      Marker 1 [T1 ]  
 \*VBW 100 kHz      -0.96 dBm  
 Ref 20 dBm      \*Att 30 dB      \*SWT 340 ms      2.440910000 GHz

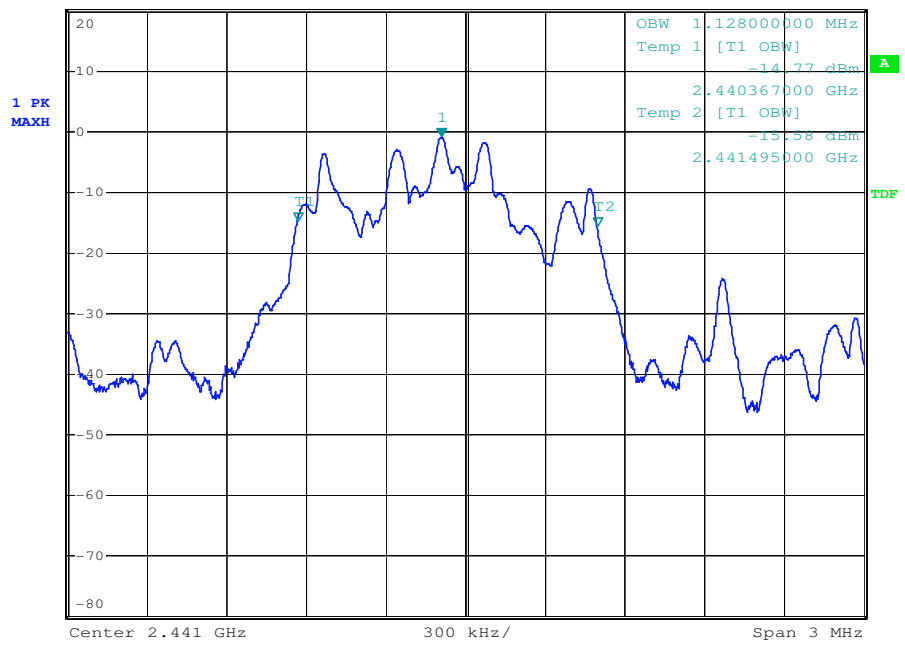

This document is issued by the Company subject to its General Conditions of Service printed overleaf, available on request or accessible at [www.sgs.com/terms\\_and\\_conditions.htm](http://www.sgs.com/terms_and_conditions.htm) and, for electronic format documents, subject to Terms and Conditions for Electronic Documents at [www.sgs.com/terms\\_e-document.htm](http://www.sgs.com/terms_e-document.htm). Attention is drawn to the limitation of liability, indemnification and jurisdiction issues defined therein. Any holder of this document is advised that information contained hereon reflects the Company's findings at the time of its intervention only and within the limits of Client's instructions, if any. The Company's sole responsibility is to its Client and this document does not exonerate parties to a transaction from exercising all their rights and obligations under the transaction documents. This document cannot be reproduced except in full, without prior written approval of the Company. Any unauthorized alteration, forgery or falsification of the content or appearance of this document is unlawful and offenders may be prosecuted to the fullest extent of the law. Unless otherwise stated the results shown in this test report refer only to the sample(s) tested and such sample(s) are retained for 90 days only



Test mode:	8DPSK	Test channel:	Highest
------------	-------	---------------	---------



\*RBW 30 kHz      Marker 1 [T1 ]  
 \*VBW 100 kHz      -0.17 dBm  
 \*Att 30 dB      \*SWT 340 ms      2.479907000 GHz

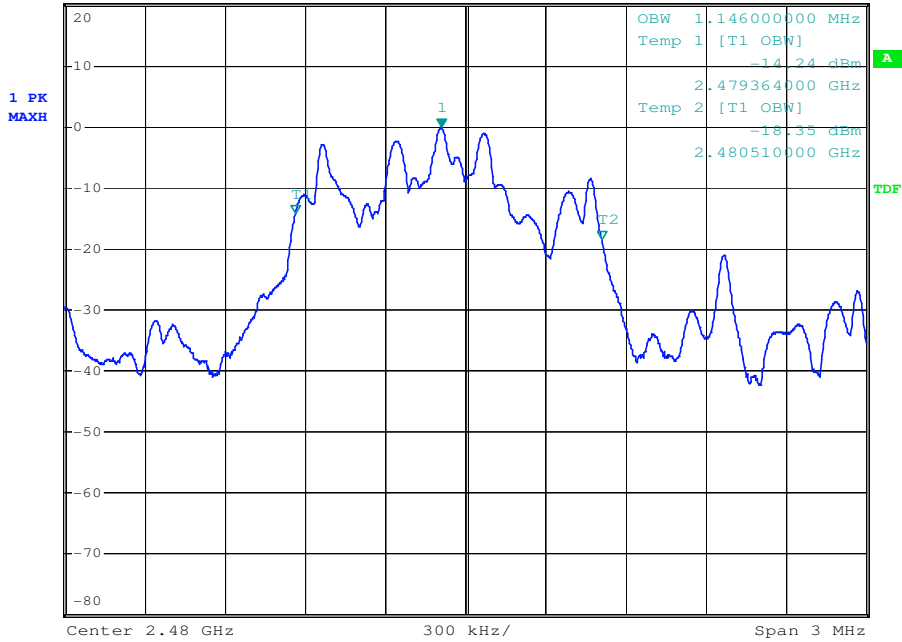

This document is issued by the Company subject to its General Conditions of Service printed overleaf, available on request or accessible at [www.sgs.com/terms\\_and\\_conditions.htm](http://www.sgs.com/terms_and_conditions.htm) and, for electronic format documents, subject to Terms and Conditions for Electronic Documents at [www.sgs.com/terms\\_e-document.htm](http://www.sgs.com/terms_e-document.htm). Attention is drawn to the limitation of liability, indemnification and jurisdiction issues defined therein. Any holder of this document is advised that information contained hereon reflects the Company's findings at the time of its intervention only and within the limits of Client's instructions, if any. The Company's sole responsibility is to its Client and this document does not exonerate parties to a transaction from exercising all their rights and obligations under the transaction documents. This document cannot be reproduced except in full, without prior written approval of the Company. Any unauthorized alteration, forgery or falsification of the content or appearance of this document is unlawful and offenders may be prosecuted to the fullest extent of the law. Unless otherwise stated the results shown in this test report refer only to the sample(s) tested and such sample(s) are retained for 90 days only

## **8 Test Setup Photographs**

Refer to the < Air 100 V2 \_Test Setup photos-FCC>.

## **9 EUT Constructional Details**

Refer to the < Air 100 V2 \_External Photos-FCC > & < Air 100 V2 \_Internal Photos-FCC>.

**--End of the Report--**