



588 West Jindu Road, Songjiang District, Shanghai, China

Telephone: +86 (0) 21 6191 5666  
Fax: +86 (0) 21 6191 5678  
ee.shanghai@sgs.com

Report No.: SHEM120700108207  
Page: 1 of 79

## **TEST REPORT**

**Application No. :** SHEM1207001082RF  
**Applicant:** Audio Partnership Plc  
**Equipment Under Test (EUT):**  
**NOTE:** The following sample(s) submitted was/were identified on behalf of the client as  
**EUT Name:** Wireless Music System  
**Brand Name:** Cambridge Audio  
**Model No:** AIR100  
**FCC ID:** YKBMA100-002  
**IC ID:** 9095A-MA100002  
**Standards:** FCC PART 15 SUBPART C, Section 15.247  
RSS-210 Issue 8 (December 2010)  
RSS-Gen Issue 3 (December 2010)  
**Date of Receipt:** July 31, 2012  
**Date of Test:** August 04, 2012 to September 26, 2012  
**Date of Issue:** September 30, 2012  
**Test Result :** **PASS \***

\* In the configuration tested, the EUT complied with the standards specified above.

E&E Section Head  
SGS-CSTC(Shanghai) Co., Ltd.

E&E EMC Engineer  
SGS-CSTC(Shanghai) Co., Ltd.

This document is issued by the Company subject to its General Conditions of Service printed overleaf, available on request or accessible at [www.sgs.com/terms\\_and\\_conditions.htm](http://www.sgs.com/terms_and_conditions.htm) and, for electronic format documents, subject to Terms and Conditions for Electronic Documents at [www.sgs.com/terms\\_e-document.htm](http://www.sgs.com/terms_e-document.htm). Attention is drawn to the limitation of liability, indemnification and jurisdiction issues defined therein. Any holder of this document is advised that information contained hereon reflects the Company's findings at the time of its intervention only and within the limits of Client's instructions, if any. The Company's sole responsibility is to its Client and this document does not exonerate parties to a transaction from exercising all their rights and obligations under the transaction documents. This document cannot be reproduced except in full, without prior written approval of the Company. Any unauthorized alteration, forgery or falsification of the content or appearance of this document is unlawful and offenders may be prosecuted to the fullest extent of the law. Unless otherwise stated the results shown in this test report refer only to the sample(s) tested and such sample(s) are retained for 90 days only



## 2 Test Summary

TEST ITEM	FCC REFERANCE	IC REFERANCE	Test Procedure	RESULT
Power line conducted emission	15.207	RSS-Gen Issue 8 Clause 7.2.4	ANSI C63.4,2003	Pass
Radiated Spurious Emission	15.205 & 15.209	RSS-210 Issue 8 Clause 2	ANSI C63.4,2003	Pass
Minimum 6dB Bandwidth	15.247(a)(2)	RSS-210 Issue 8 Annex 8	ANSI C63.10,2009	Pass
Maximum peak output power	15.247(b)	RSS-210 Issue 8 Annex 8	ANSI C63.10,2009	Pass
Power spectrum density	15.247(e)	RSS-210 Issue 8 Annex 8	ANSI C63.10,2009	Pass
Radiated Emission BandEdge	15.247(c)	---	ANSI C63.4,2003	Pass
Emission outside the Frequency band	15.247(d)	RSS-210 Issue 8 Annex 8	ANSI C63.4,2003	Pass
Occupied bandwidth	---	RSS-Gen Issue 3 Clause 4.6.1	RSS-Gen Issue 3 Clause 4.6.1	Tested



### **3 Contents**

	Page
<b>1 COVER PAGE .....</b>	<b>1</b>
<b>2 TEST SUMMARY .....</b>	<b>2</b>
<b>3 CONTENTS .....</b>	<b>3</b>
<b>4 GENERAL INFORMATION.....</b>	<b>4</b>
4.1 CLIENT INFORMATION .....	4
4.2 GENERAL DESCRIPTION OF E.U.T. ....	4
4.3 DETAILS OF E.U.T. ....	4
4.4 DETAILS OF TEST MODE.....	5
4.5 STANDARDS APPLICABLE FOR TESTING .....	5
4.6 TEST LOCATION .....	6
4.7 OTHER INFORMATION REQUESTED BY THE CUSTOMER.....	6
4.8 TEST FACILITY .....	6
<b>5 TEST INSTRUMENTS.....</b>	<b>7</b>
<b>6 TEST PROCEDURE &amp; MEASUREMENT DATA.....</b>	<b>9</b>
6.1 E.U.T. OPERATION.....	9
6.2 CONDUCTED EMISSION TEST .....	9
6.3 RADIATED SPURIOUS EMISSION TEST .....	12
6.4 6dB BANDWIDTH.....	20
6.5 PEAK OUTPUT POWER MEASUREMENT .....	27
6.6 RADIATED EMISSION BAND EDGE .....	35
6.7 CONDUCTED SPURIOUS EMISSION TEST .....	53
6.8 PEAK POWER SPECTRAL DENSITY .....	64
6.9 OCCUPIED BANDWIDTH TEST.....	71
<b>7 TEST SETUP PHOTOGRAPHS .....</b>	<b>78</b>
<b>8 EUT CONSTRUCTIONAL DETAILS.....</b>	<b>78</b>

## 4 General Information

### 4.1 Client Information

Applicant:	Audio Partnership Plc
Address of Applicant:	Gallery Court, Hankey Place London, SE1 4BB United Kingdom
Manufacturer:	Audio Partnership Plc
Address of Manufacturer:	Gallery Court, Hankey Place London, SE1 4BB United Kingdom
Factory:	Hansong(Nanjing) Technology Ltd.

### 4.2 General Description of E.U.T.

Product Name:	Wireless Music System
Model No.(EUT):	AIR100
Add Model No.:	N/A
Model Difference:	N/A
Trade Mark:	Cambridge Audio
Supported Frequency Bands:	WiFi (802.11 b/g): 2.412 to 2.462GHz Bluetooth(BT): 2.402GHz to 2.480GHz

### 4.3 Details of E.U.T.

#### Technical Specifications:

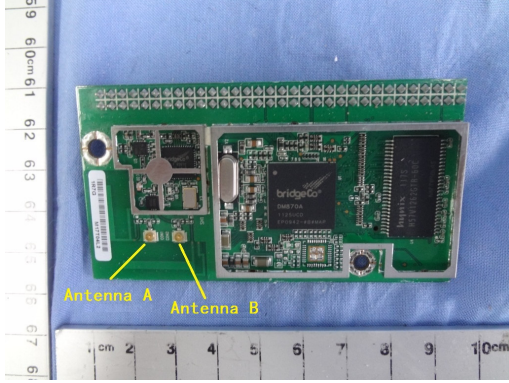
Modulation Technique:	<input checked="" type="checkbox"/> 802.11b: DSSS <input checked="" type="checkbox"/> 802.11g: OFDM
Modulation Type:	<input checked="" type="checkbox"/> 802.11b: DSSS(CCK, DQPSK, DBPSK) <input checked="" type="checkbox"/> 802.11g: OFDM(64QAM, 16QAM, QPSK, BPSK)
Frequency Range / Channel Number:	<input checked="" type="checkbox"/> 802.11b/g: 2412-2462MHz / 11 Channels
Data Rate:	<input checked="" type="checkbox"/> 802.11b: 1Mbps, 5.5Mbps, 11Mbps, <input checked="" type="checkbox"/> 802.11g: 6Mbps, 9Mbps, 12Mbps, 18Mbps, 36Mbps, 48Mbps, 54Mbps
Equipment classification:	<input checked="" type="checkbox"/> equipment for fixed use
Antenna Type:	<p>Double PIFA antenna (as below figure)</p>  <p>Remark: the two PIFA antennas are not working simultaneously.</p>
Antenna Gain:	3.0 dBi

**Power Supply:**

Rated Input:	100-230VAC, 50/60Hz
Power Cable:	2 wires
	1.5m

**4.4 Details of Test Mode**

Using test software was control EUT work in continuous transmitter and receiver mode. And select test channel as below:

For 802.11b/g

Channel	Frequency
The lowest channel(CH1)	2412MHz
The middle channel(CH6)	2437MHz
The Highest channel(CH11)	2462MHz

Through Pre-scan under all rate at lowest channel 1(CH1), the data rate as below table described is the worst case, so we chose these data rate for test.

Type	Data rate
802.11b	1Mbps

**4.5 Standards Applicable for Testing**

The standard used were FCC PART 15 Subpart C: 2011, ANSI C63.10: 2009. RSS-210 Issue 8, RSS-Gen Issue 3.

#### **4.6 Test Location**

Tests were performed at:

SGS-CSTC Standards Technical Services (Shanghai) Co., Ltd.  
No.588 West Jindu Road, Songjiang District, Shanghai, China. 201612.

Tel: +86 21 6191 5666 Fax: +86 21 6191 5655

#### **4.7 Other Information Requested by the Customer**

None.

#### **4.8 Test Facility**

The test facility is recognized, certified, or accredited by the following organizations:

- **CNAS (No. CNAS L0599)**

CNAS has accredited SGS-CSTC Standards Technical Services (Shanghai) Co., Ltd. to ISO/IEC 17025:2005 General Requirements for the Competence of Testing and Calibration Laboratories (CNAS-CL01 Accreditation Criteria for the Competence of Testing and Calibration Laboratories) for the competence in the field of testing. Date of expiry: 2014-07-26.

- **FCC – Registration No.: 402683**

SGS-CSTC Standards Technical Services (Shanghai) Co., Ltd. has been registered and fully described in a report filed with the Federal Communications Commission (FCC). The acceptance letter from the FCC is maintained in our files. Registration No.: 402683, Expiry Date: 2012-03-17.

- **Industry Canada (IC) – IC Assigned Code: 8617A**

The 3m Semi-anechoic chamber of SGS-CSTC Standards Technical Services (Shanghai) Co., Ltd. has been registered by Certification and Engineering Bureau of Industry Canada for radio equipment testing with Registration No.: 8617A. Expiry Date: 2014-09-20.

- **VCCI (Member No.: 3061)**

The 3m Semi-anechoic chamber and Shielded Room of SGS-CSTC Standards Technical Services (Shanghai) Co., Ltd. has been registered in accordance with the Regulations for Voluntary Control Measures with Registration No.: R-3172 and C-3514 respectively. Date of Registration: 2009-11-30. Date of Expiry: 2012-03-17.



## 5 Test Instruments

Item	Test Equipment	Manufacturer	Model No.	Serial No.	Cal. Date	Cal. Due date
1	EMI test receiver	Rohde & Schwarz	ESU40	100109	2012-06-03	2013-06-01
2	Horn Antenna	SCHWARZBECK	BBHA9120D	9120D-679	2012-06-03	2013-06-01
3	Horn Antenna	Rohde & Schwarz	HF906	100284	2012-03-12	2013-03-10
4	ANTENNA	SCHWARZBECK	VULB9168	9168-313	2012-06-03	2013-06-01
5	Ultra broadband antenna	Rohde & Schwarz	HL562	100227	2011-10-09	2012-10-08
6	Atmosphere pressure meter	Shanghai ZhongXuan Electronic Co;Ltd	BY—2009P	--	2011-10-15	2012-10-14
7	CLAMP METER	FLUKE	316	86080010	2012-04-22	2013-04-20
8	Thermo-Hygrometer	ZHICHEN	ZC1-2	01050033	2011-10-14	2012-10-13
9	High-low temperature cabinet	Shanghai YuanZhen	GW2050	--	2012-06-17	2013-06-16
11	Tunable Notch Filter	Wainwright instruments Gmbh	WRCT1800.0/2000.0-0.2/40-5SSK	11	2012-06-26	2013-06-25
12	Tunable Notch Filter	Wainwright instruments Gmbh	WRCT800.0/80.0-0.2/40-5SSK	9	2012-06-26	2013-06-25
13	High pass Filter	FSCW	HP 12/2800-5AA2	19A45-02	2012-04-08	2013-04-07
14	Low noise amplifier	TESEQ	LNA6900	70133	2012-07-05	2013-07-04
15	EMI test receiver	Rohde & Schwarz	ESCS30	100086	2012-06-04	2013-06-03



16	Line impedance stabilization network	SCHWARZBECK	NSLK8127	8127-490	2012-05-07	2013-05-06
----	---	-------------	----------	----------	------------	------------





## 6 Test Procedure & Measurement Data

### 6.1 E.U.T. Operation

Input voltage: 100-230VAC, 50/60Hz

Operating Environment:

Temperature: 20.0 -25.0 °C

Humidity: 35-75 % RH

Atmospheric Pressure: 992 -1020 mbar

EUT Operation: The EUT has been tested under operating condition.

Test program was used to control the EUT for staying in continuous transmitting and receiving mode is programmed.

Channel low (2412MHz) mid(2437MHz) high(2462MHz)

### 6.2 Conducted Emission Test

**Test Requirement:** FCC Part15C 15.207

**Test date:** August. 06, 2012

**Standard Applicable** According to section 15.207,frequency 150KHz to 30MHz shall not exceed the limit table as blew.

Frequency of Emission (MHz)	Conducted Limit (dBuV)	
	Quasi-peak	Average
0.15-0.5	66 to 56*	56 to 46*
0.5-5	56	46
5-30	60	50

#### EUT Setup

1.The conducted emission tests were performed in the test site,using the setup in accordance with the ANSI C63.10-2009.

2.EUT is charged with PC.The AC Power adaptor of PC was plug-in LISN.The rear of the EUT and periphearals were placed flushed with the rear of the tabletop.

3.The LISN was connected with 120V AC/60Hz power source.

#### Measurement Result

Operation mode:Normal Link Mode

Note:All test modes have been tested.

**L line:**

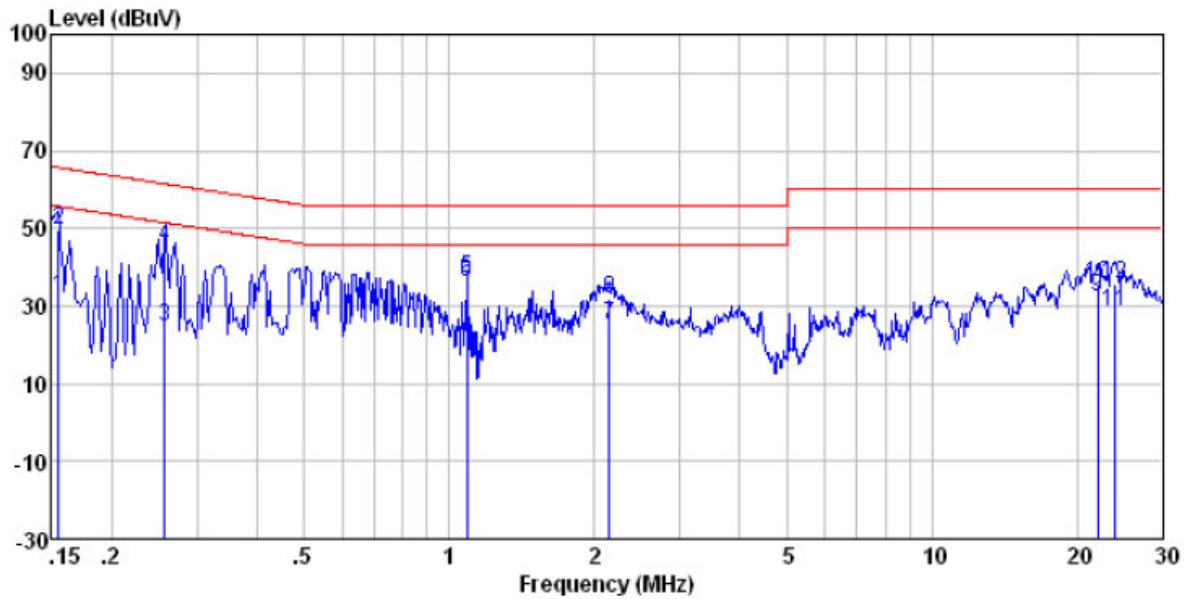

	Freq	Read Level	Cable Loss	LISII Factor	Level	Limit Line	Over Limit	Remark
	MHz	dBuV	dB	dB	dBuV	dBuV	dB	
1	0.15	32.30	0.10	0.19	32.59	55.74	-23.15	Average
2	0.15	49.26	0.10	0.19	49.55	65.74	-16.19	QP
3	0.26	24.26	0.10	0.12	24.48	51.51	-27.03	Average
4	0.26	45.14	0.10	0.12	45.36	61.51	-16.15	QP
5	1.09	36.66	0.10	0.21	36.97	46.00	-9.03	Average
6	1.09	36.06	0.10	0.21	36.37	56.00	-19.63	QP
7	2.14	24.87	0.10	0.30	25.27	46.00	-20.73	Average
8	2.14	31.29	0.10	0.30	31.69	56.00	-24.31	QP
9	22.06	31.68	0.20	0.68	32.56	50.00	-17.44	Average
10	22.06	34.94	0.20	0.68	35.82	60.00	-24.18	QP
11	24.01	27.41	0.20	0.76	28.37	50.00	-21.63	Average
12	24.01	34.58	0.20	0.76	35.54	60.00	-24.46	QP

**N Line:**

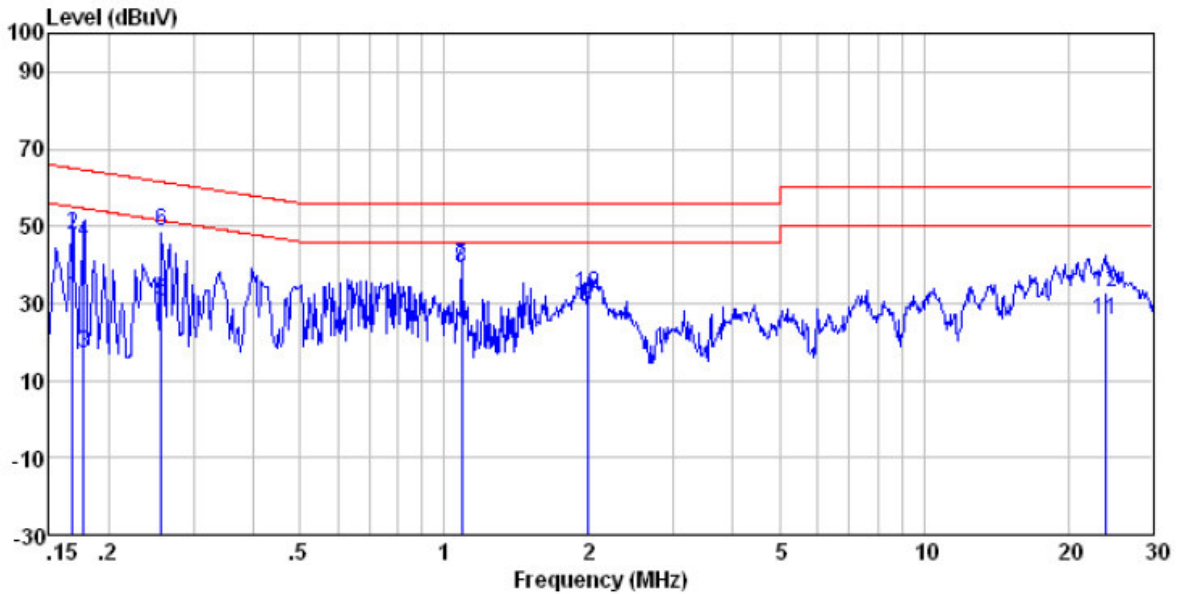

	Read Freq	Read Level	Cable Loss	LISII Factor	LISII Level	Limit Line	Over Limit	Remark
	MHz	dBuV	dB	dB	dBuV	dBuV	dB	
1	0.17	31.11	0.10	0.16	31.37	55.08	-23.71	Average
2	0.17	47.47	0.10	0.16	47.73	65.08	-17.35	QP
3	0.18	16.56	0.10	0.15	16.81	54.64	-37.83	Average
4	0.18	45.71	0.10	0.15	45.96	64.64	-18.68	QP
5	0.26	30.36	0.10	0.12	30.58	51.51	-20.93	Average
6	0.26	48.23	0.10	0.12	48.45	61.51	-13.06	QP
7	1.09	39.12	0.10	0.21	39.43	46.00	-6.57	Average
8	1.09	38.60	0.10	0.21	38.91	56.00	-17.09	QP
9	1.99	28.77	0.10	0.30	29.17	46.00	-16.83	Average
10	1.99	32.20	0.10	0.30	32.60	56.00	-23.40	QP
11	24.01	24.64	0.20	0.76	25.60	50.00	-24.40	Average
12	24.01	31.86	0.20	0.76	32.82	60.00	-27.18	QP

### 6.3 Radiated Spurious Emission Test

**Test Requirement:** FCC Part15 247(c)

**Test date:** August 14,2012

**Standard Applicable:** According to section 15.247(c),all other emissions outside these bands shall not exceed the general radiated emission limits specified in section15.209(a).And according to section 15.33(a)(1),for an intentional radiator operates below 10GHz,the frequency range of measurements:to the tenth harmonic of the highest fundamental frequency or to 40GHz,which is lower.

- Measurement Procedure:**
1. The EUT was placed on a turn table which is 0.8m above ground plane.
  2. The turn table shall rotate 360 degrees to determine the position of maximum emission level.
  3. EUT is set 3m away from the receiving antenna which varied from 1m to 4m to find out the highest emissions.  
Test instrumentation resolution bandwidth 120 kHz and Quasi-Peak detector applies (30 MHz - 1000 MHz). 1MHz resolution bandwidth and Peak detector apply (1000 MHz – 25GHz )  
Above 1GHz  
(a) PEAK: RBW=VBW=1MHz / Sweep=AUTO  
(b) AVERAGE: RBW=1MHz / VBW=10Hz / Sweep=AUTO.
  4. Maximum procedure was performed on the six highest emissions to ensure EUT compliance.
  5. And also, each emission was to be maximized by changing the polarization of receiving antenna both horizontal and vertical.
  6. Repeat above procedures until all frequency measured were complete.

#### Radiated Test Set-up:

#### Radiated Emission Test Set-up,Frequency Below 1000MHz

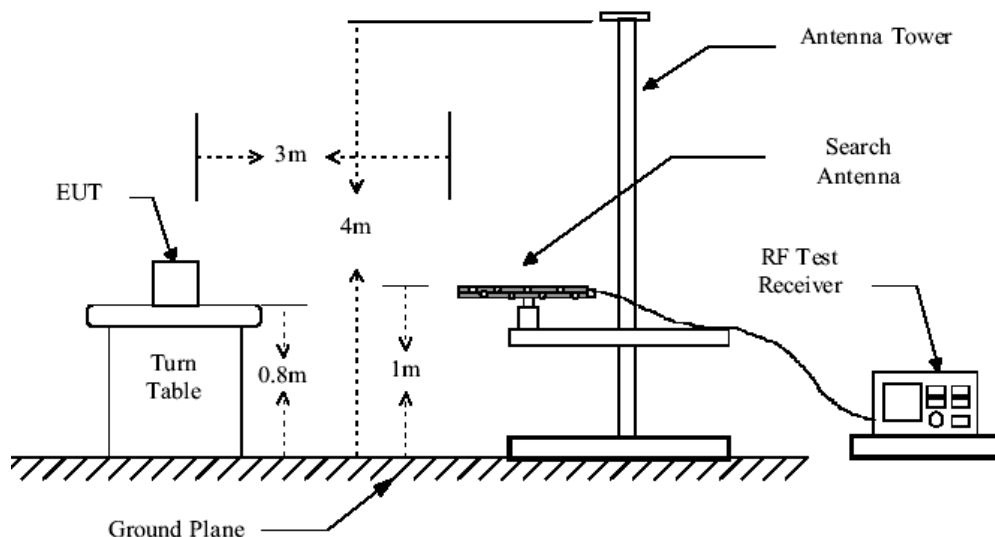

**Radiated Emission Test Set-up Frequency Over 1GHz**

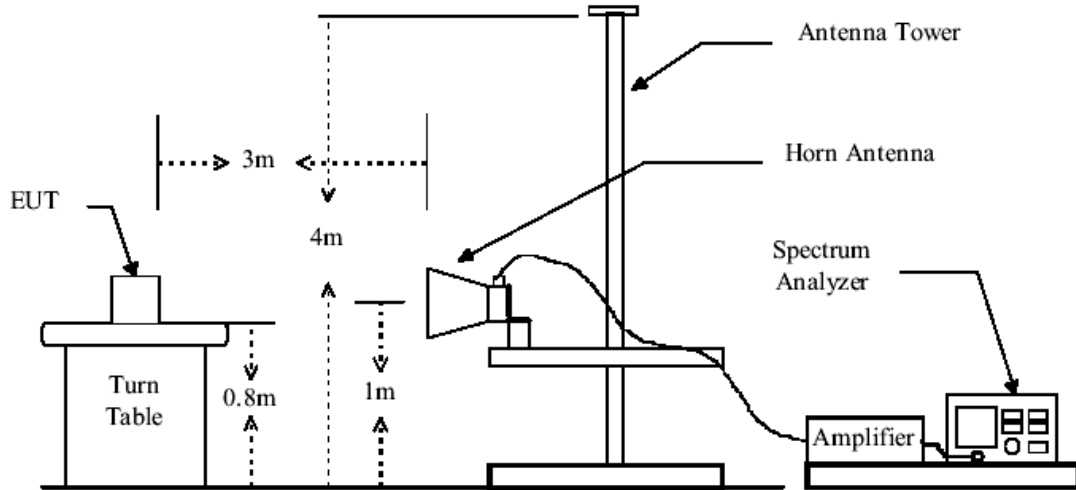

Low noise amplifier was used below 1GHz, High pass Filter was used above 1GHz.

**Operation Mode: TX Low Mid CH 2412MHz Antenna A**

**30MHz~1GHz Spurious Emissions .Quasi-Peak Measurement**

Frequency (MHz)	Antenna factors (dB/m)	Cable loss (dB)	Preamp factor (dB)	Reading Level (dBμV)	Emission Level (dBμV/m)	Limit (dBμV/m)	Antenna polarization
440.12	11.5	1.5	24.5	48.92	37.42	46.00	Vertical
233.31	14.5	2.1	24.4	45.50	37.70	46.00	Horizontal

**1~25 GHz Harmonics & Spurious Emissions. Peak & Average Measurement**

**Peak Measurement:**

Frequency (MHz)	Antenna factors (dB/m)	Cable loss (dB)	Filter (dB)	Preamp factor (dB)	Reading Level (dBμV)	Emission Level (dBμV /m)	Limit (dBμV /m)	Antenna polarization
4824.0	31.0	1.2	0.5	43.4	57.48	46.78	74	Vertical
7236.0	35.5	1.7	0.6	43.1	46.38	41.08	74	Vertical
9648.0	37.7	2.1	0.9	43.3	48.85	46.25	74	Vertical
4824.0	31.0	1.2	0.5	43.4	55.22	44.52	74	Horizontal
7236.0	35.5	1.7	0.6	43.1	46.44	41.14	74	Horizontal
9648.0	37.7	2.1	0.9	43.3	44.43	41.83	74	Horizontal



**Average Measurement:**

Frequency (MHz)	Antenna factors (dB/m)	Cable loss (dB)	Filter (dB)	Preamp factor (dB)	Reading Level (dBμV)	Emission Level (dBμV /m)	Limit (dBμV /m)	Antenna polarization
4824.0	31.0	1.2	0.5	43.4	48.97	38.27	54	Vertical
7236.0	35.5	1.7	0.6	43.1	36.42	31.12	54	Vertical
9648.0	37.7	2.1	0.9	43.3	37.80	35.20	54	Vertical
4824.0	31.0	1.2	0.5	43.4	45.98	35.28	54	Horizontal
7236.0	35.5	1.7	0.6	43.1	36.65	31.35	54	Horizontal
9648.0	37.7	2.1	0.9	43.3	35.27	32.67	54	Horizontal

The field strength is calculated by adding the Antenna Factor. Cable Factor & Pre-amplifier. The basic equation with a sample calculation is as follows:

$$\text{Final Test Level} = \text{Receiver Reading} + \text{Antenna Factor} + \text{Cable Factor} + \text{Filter} - \text{Pre-amplifier Factor}$$

**Operation Mode: TX Mid CH 2437MHz Antenna A**

30MHz~1GHz Spurious Emissions .Quasi-Peak Measurement

Frequency (MHz)	Antenna factors (dB/m)	Cable loss (dB)	Preamp factor (dB)	Reading Level (dBμV)	Emission Level (dBμV/m)	Limit (dBμV/m)	Antenna polarization
110.70	11.5	1.5	24.5	49.00	37.50	43.50	Vertical
110.70	14.5	2.1	24.4	45.27	37.47	43.50	Horizontal

1~25 GHz Harmonics & Spurious Emissions. Peak & Average Measurement

**Peak Measurement:**

Frequency (MHz)	Antenna factors (dB/m)	Cable loss (dB)	Filter (dB)	Preamp factor (dB)	Reading Level (dBμV)	Emission Level (dBμV/m)	Limit (dBμV/m)	Antenna polarization
4876.0	31.1	1.3	0.5	43.5	52.36	41.76	74	Vertical
7314.0	35.7	1.7	0.6	43.1	46.76	41.66	74	Vertical
9752.0	37.8	2.1	0.9	43.0	47.26	45.06	74	Vertical
4876.0	31.1	1.3	0.5	43.5	56.27	45.67	74	Horizontal
7314.0	35.7	1.7	0.6	43.1	46.73	41.63	74	Horizontal
9752.0	37.8	2.1	0.9	43.0	48.45	46.25	74	Horizontal



**Average Measurement:**

Frequency (MHz)	Antenna factors (dB/m)	Cable loss (dB)	Filter (dB)	Preamp factor (dB)	Reading Level (dBμV)	Emission Level (dBμV/m)	Limit (dBμV/m)	Antenna polarization
4876.0	31.1	1.3	0.5	43.5	46.10	35.50	54	Vertical
7314.0	35.7	1.7	0.6	43.1	37.24	32.14	54	Vertical
9752.0	37.8	2.1	0.9	43.0	37.34	35.14	54	Vertical
4876.0	31.1	1.3	0.5	43.5	49.32	38.72	54	Horizontal
7314.0	35.7	1.7	0.6	43.1	36.12	31.02	54	Horizontal
9752.0	37.8	2.1	0.9	43.0	37.52	35.32	54	Horizontal

The field strength is calculated by adding the Antenna Factor. Cable Factor & Pre-amplifier. The basic equation with a sample calculation is as follows:

$$\text{Final Test Level} = \text{Receiver Reading} + \text{Antenna Factor} + \text{Cable Factor} + \text{Filter} - \text{Pre-amplifier Factor}$$

**Operation Mode:TX High CH 2462MHz Antenna A**

**30MHz~1GHz Spurious Emissions .Quasi-Peak Measurement**

Frequency (MHz)	Antenna factors (dB/m)	Cable loss (dB)	Preamp factor (dB)	Reading Level (dBμV)	Emission Level (dBμV/m)	Limit (dBμV/m)	Antenna polarization
110.70	11.5	1.5	24.5	49.51	38.01	43.50	Vertical
110.70	14.5	2.1	24.4	36.37	28.57	43.50	Horizontal

**1~25 GHz Harmonics & Spurious Emissions. Peak & Average Measurement**

**Peak Measurement:**

Frequency (MHz)	Antenna factors (dB/m)	Cable loss (dB)	Filter (dB)	Preamp factor (dB)	Reading Level (dBμV/m)	Emission Level (dBμV/m)	Limit (dBμV/m)	Antenna polarization
4928.0	31.4	1.4	0.5	43.9	53.06	42.46	74	Vertical
7392.0	35.8	1.7	0.6	43.1	46.57	41.57	74	Vertical
9856.0	38.0	2.2	0.9	42.8	46.22	44.52	74	Vertical
4928.0	31.4	1.4	0.5	43.9	56.92	46.32	74	Horizontal
7392.0	35.8	1.7	0.6	43.1	49.56	44.56	74	Horizontal
9856.0	38.0	2.2	0.9	42.8	46.78	45.08	74	Horizontal



**Average Measurement:**

Frequency (MHz)	Antenna factors (dB/m)	Cable loss (dB)	Filter (dB)	Preamp factor (dB)	Reading Level (dBV)	Emission Level (dBμV/m)	Limit (dBμV/m)	Antenna polarization
4928.0	31.4	1.4	0.5	43.9	47.54	36.94	54	Vertical
7392.0	35.8	1.7	0.6	43.1	35.78	30.78	54	Vertical
9856.0	38.0	2.2	0.9	42.8	35.94	34.24	54	Vertical
4928.0	31.4	1.4	0.5	43.9	51.93	41.33	54	Horizontal
7392.0	35.8	1.7	0.6	43.1	37.65	32.65	54	Horizontal
9856.0	38.0	2.2	0.9	42.8	36.48	34.78	54	Horizontal

The field strength is calculated by adding the Antenna Factor. Cable Factor & Pre-amplifier. The basic equation with a sample calculation is as follows:

1. Final Test Level = Receiver Reading + Antenna Factor + Cable Factor + Filter - Pre-amplifier Factor

**Operation Mode: TX Low Mid CH 2412MHz Antenna B**

**30MHz~1GHz Spurious Emissions .Quasi-Peak Measurement**

Frequency (MHz)	Antenna factors (dB/m)	Cable loss (dB)	Preamp factor (dB)	Reading Level (dBμV)	Emission Level (dBμV/m)	Limit (dBμV/m)	Antenna polarization
387.48	11.5	1.5	24.5	47.88	36.38	46.00	Vertical
211.28	14.5	2.1	24.4	43.07	35.27	43.50	Horizontal

**1~25 GHz Harmonics & Spurious Emissions. Peak & Average Measurement**

**Peak Measurement:**

Frequency (MHz)	Antenna factors (dB/m)	Cable loss (dB)	Filter (dB)	Preamp factor (dB)	Reading Level (dBμV)	Emission Level (dBμV/m)	Limit (dBμV/m)	Antenna polarization
4830.44	31.0	1.2	0.5	43.4	59.18	48.48	74	Vertical
7241.73	35.5	1.7	0.6	43.1	48.68	43.38	74	Vertical
9654.08	37.7	2.1	0.9	43.3	51.85	49.25	74	Vertical
4830.22	31.0	1.2	0.5	43.4	56.92	46.22	74	Horizontal
7241.74	35.5	1.7	0.6	43.1	48.74	43.44	74	Horizontal
9653.64	37.7	2.1	0.9	43.3	47.43	44.83	74	Horizontal



**Average Measurement:**

Frequency (MHz)	Antenna factors (dB/m)	Cable loss (dB)	Filter (dB)	Preamp factor (dB)	Reading Level (dBμV)	Emission Level (dBμV /m)	Limit (dBμV /m)	Antenna polarization
4831.64	31.0	1.2	0.5	43.4	50.87	40.17	54	Vertical
7243.43	35.5	1.7	0.6	43.1	38.27	32.97	54	Vertical
9656.18	37.7	2.1	0.9	43.3	39.47	36.87	54	Vertical
4831.42	31.0	1.2	0.5	43.4	47.88	37.18	54	Horizontal
7243.44	35.5	1.7	0.6	43.1	38.50	33.20	54	Horizontal
9655.74	37.7	2.1	0.9	43.3	36.94	34.34	54	Horizontal

The field strength is calculated by adding the Antenna Factor. Cable Factor & Pre-amplifier. The basic equation with a sample calculation is as follows:

$$\text{Final Test Level} = \text{Receiver Reading} + \text{Antenna Factor} + \text{Cable Factor} + \text{Filter} - \text{Pre-amplifier Factor}$$

**Operation Mode: TX Mid CH 2437MHz Antenna B**

30MHz~1GHz Spurious Emissions .Quasi-Peak Measurement

Frequency (MHz)	Antenna factors (dB/m)	Cable loss (dB)	Preamp factor (dB)	Reading Level (dBμV)	Emission Level (dBμV/m)	Limit (dBμV/m)	Antenna polarization
165.43	11.5	1.5	24.5	49.12	49.12	43.50	Vertical
178.69	14.5	2.1	24.4	43.34	43.34	43.50	Horizontal

1~25 GHz Harmonics & Spurious Emissions. Peak & Average Measurement

**Peak Measurement:**

Frequency (MHz)	Antenna factors (dB/m)	Cable loss (dB)	Filter (dB)	Preamp factor (dB)	Reading Level (dBμV)	Emission Level (dBμV/m)	Limit (dBμV/m)	Antenna polarization
4878.92	31.1	1.3	0.5	43.5	48.924	38.32	74	Vertical
7321.86	35.7	1.7	0.6	43.1	44.384	39.28	74	Vertical
9762.37	37.8	2.1	0.9	43.0	45.534	43.33	74	Vertical
4878.96	31.1	1.3	0.5	43.5	52.443	41.84	74	Horizontal
7321.86	35.7	1.7	0.6	43.1	44.357	39.25	74	Horizontal
9762.38	37.8	2.1	0.9	43.0	46.605	44.40	74	Horizontal

**Average Measurement:**

Frequency (MHz)	Antenna factors (dB/m)	Cable loss (dB)	Filter (dB)	Preamp factor (dB)	Reading Level (dBμV)	Emission Level (dBμV/m)	Limit (dBμV/m)	Antenna polarization
4880.87	31.1	1.3	0.5	43.5	47.21	36.61	54	Vertical
7321.32	35.7	1.7	0.6	43.1	38.69	33.59	54	Vertical
9761.76	37.8	2.1	0.9	43.0	38.91	36.71	54	Vertical
4880.87	31.1	1.3	0.5	43.5	50.43	39.83	54	Horizontal
7321.32	35.7	1.7	0.6	43.1	37.57	32.47	54	Horizontal
9761.76	37.8	2.1	0.9	43.0	39.09	36.89	54	Horizontal

The field strength is calculated by adding the Antenna Factor. Cable Factor & Pre-amplifier. The basic equation with a sample calculation is as follows:

$$\text{Final Test Level} = \text{Receiver Reading} + \text{Antenna Factor} + \text{Cable Factor} + \text{Filter} - \text{Pre-amplifier Factor}$$

**Operation Mode: TX High CH 2462MHz Antenna B**

**30MHz~1GHz Spurious Emissions .Quasi-Peak Measurement**

Frequency (MHz)	Antenna factors (dB/m)	Cable loss (dB)	Preamp factor (dB)	Reading Level (dBμV)	Emission Level (dBμV/m)	Limit (dBμV/m)	Antenna polarization
126.39	11.5	1.5	24.5	49.51	36.46	43.50	Vertical
156.82	14.5	2.1	24.4	36.37	31.39	43.50	Horizontal

**1~25 GHz Harmonics & Spurious Emissions. Peak & Average Measurement**

**Peak Measurement:**

Frequency (MHz)	Antenna factors (dB/m)	Cable loss (dB)	Filter (dB)	Preamp factor (dB)	Reading Level (dBμV)	Emission Level (dBμV/m)	Limit (dBμV/m)	Antenna polarization
4931.40	31.4	1.4	0.5	43.9	53.41	42.81	74	Vertical
7394.35	35.8	1.7	0.6	43.1	46.20	41.20	74	Vertical
9857.52	38.0	2.2	0.9	42.8	45.40	43.70	74	Vertical
4931.79	31.4	1.4	0.5	43.9	57.27	46.67	74	Horizontal
7394.65	35.8	1.7	0.6	43.1	49.19	44.19	74	Horizontal
9857.57	38.0	2.2	0.9	42.8	45.96	44.26	74	Horizontal



**Average Measurement:**

Frequency (MHz)	Antenna factors (dB/m)	Cable loss (dB)	Filter (dB)	Preamp factor (dB)	Reading Level (dB $\mu$ V)	Emission Level (dB $\mu$ V/m)	Limit (dB $\mu$ V/m)	Antenna polarization
4934.33	31.4	1.4	0.5	43.9	48.78	38.18	54	Vertical
7401.09	35.8	1.7	0.6	43.1	37.06	32.06	54	Vertical
9868.05	38.0	2.2	0.9	42.8	36.64	34.94	54	Vertical
4934.33	31.4	1.4	0.5	43.9	53.17	42.57	54	Horizontal
7401.09	35.8	1.7	0.6	43.1	38.93	33.93	54	Horizontal
9868.05	38.0	2.2	0.9	42.8	37.18	35.48	54	Horizontal

The field strength is calculated by adding the Antenna Factor, Cable Factor & Pre-amplifier. The basic equation with a sample calculation is as follows:

2. Final Test Level = Receiver Reading + Antenna Factor + Cable Factor + Filter - Pre-amplifier Factor



**6.4 6dB Bandwidth**

**Test Requirement:** FCC Part15 247(a)(2)  
**Test date:** September 05.2012  
**Standard Applicable:** According to section 15.247(a)(2), Systems using digital modulation techniques may operate in the 902-928MHz, 2400-2483.5MHz, and 5725-5850MHz bands. The minimum 6dB bandwidth shall be at least 500KHz.

**Measurement Procedure:**

1. Place the EUT on the table and set it in transmitting mode.
2. Remove the antenna from the EUT and then connect a low loss RF cable from the antenna port to the spectrum analyzer.
3. Set the spectrum analyzer as RBW=100KHz, VBW =3\* RBW, Span=30/ 50MHz, Sweep=auto
4. Mark the peak frequency and -6dB (upper and lower) frequency.
5. Repeat above procedures until all frequency measured were complete.

**Measurement Result:**

**Test Data for Antenna A**

**Test mode: 802.11b**

CH	Frequency (MHz)	Bandwidth (MHz)	Limit Bandwidth (KHz)	Result
Low	2412	12.60	500	PASS
Mid	2437	11.76	500	PASS
High	2462	9.84	500	PASS

**Test Data for Antenna A**

**Test mode: 802.11g**

CH	Frequency (MHz)	Bandwidth (MHz)	Limit Bandwidth (KHz)	Result
Low	2412	16.56	500	PASS
Mid	2437	16.52	500	PASS
High	2462	16.56	500	PASS

**Test Data for Antenna B**

**Test mode: 802.11b**

CH	Frequency (MHz)	Bandwidth (MHz)	Limit Bandwidth (KHz)	Result
Low	2412	11.04	500	PASS
Mid	2437	11.92	500	PASS
High	2462	12.00	500	PASS

**Test Data for Antenna B**

**Test mode: 802.11g**

CH	Frequency (MHz)	Bandwidth (MHz)	Limit Bandwidth (KHz)	Result
Low	2412	16.64	500	PASS
Mid	2437	16.56	500	PASS
High	2462	16.56	500	PASS



**Test Plots:**

**Lowest Channel for Antenna A**

**Test mode: 802.11b**

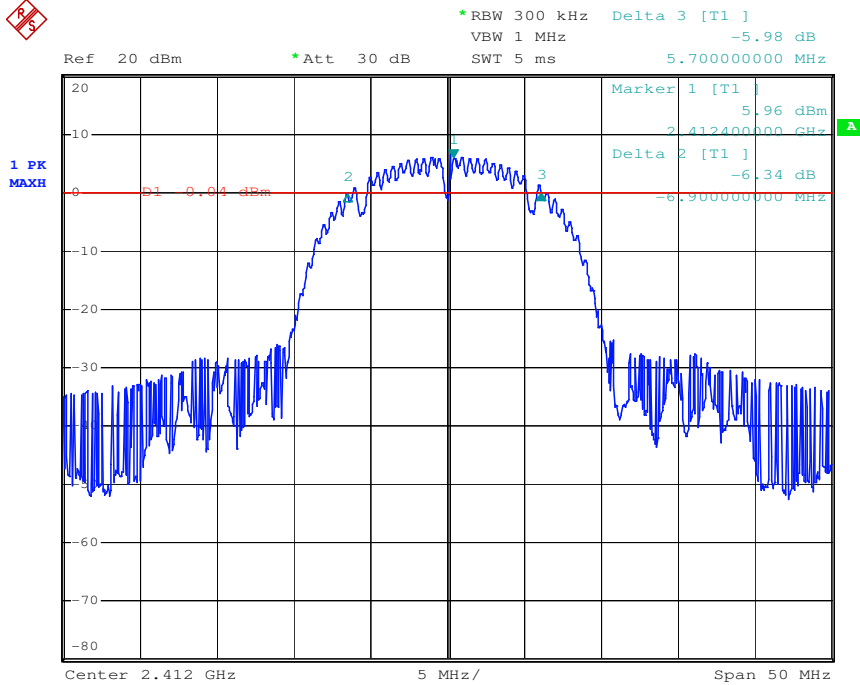

Date: 1.JAN.2000 00:25:27

**Middle Channel for Antenna A**

**Test mode: 802.11b**

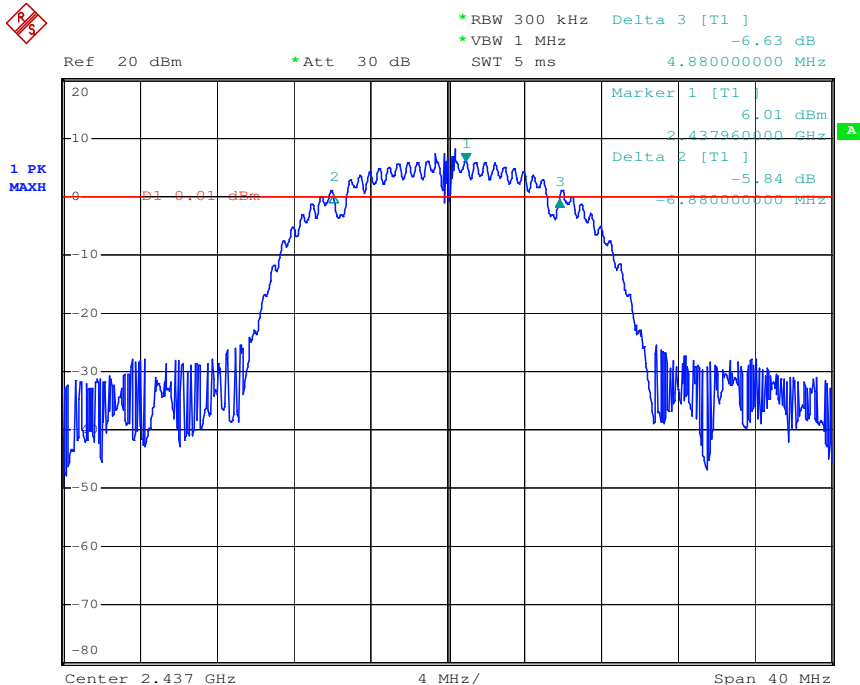

Date: 1.JAN.2000 00:44:27



Highest Channel for Antenna A

Test mode: 802.11b

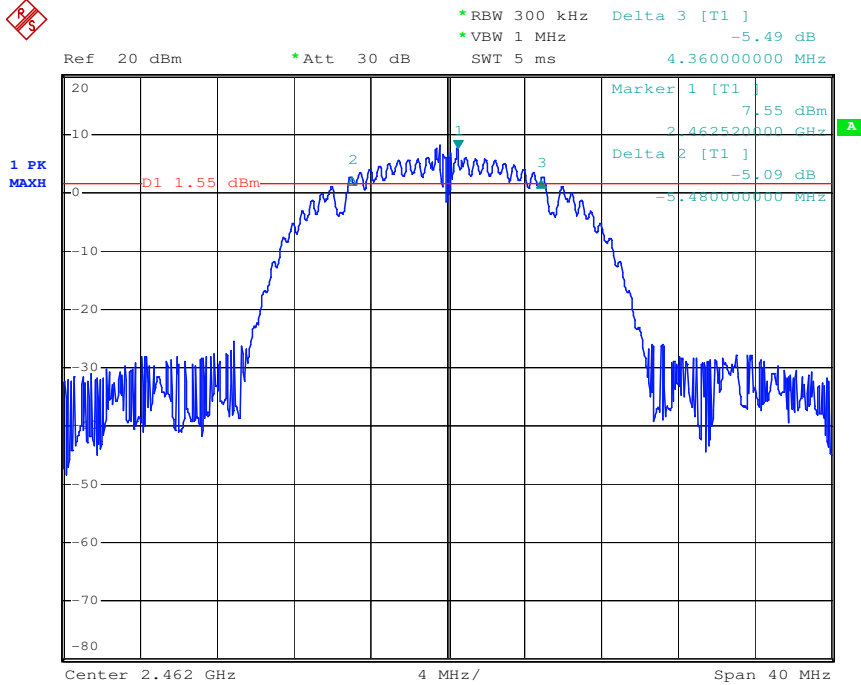

Date: 1.JAN.2000 01:11:16

Lowest Channel for Antenna A

Test mode: 802.11g

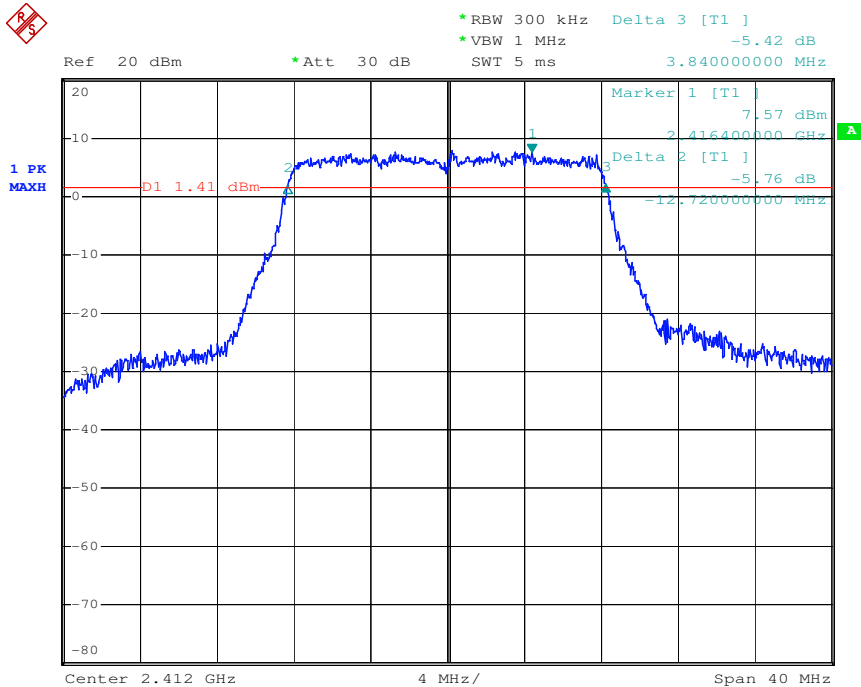

Date: 1.JAN.2000 01:23:49



Middle Channel for Antenna A

Test mode: 802.11g

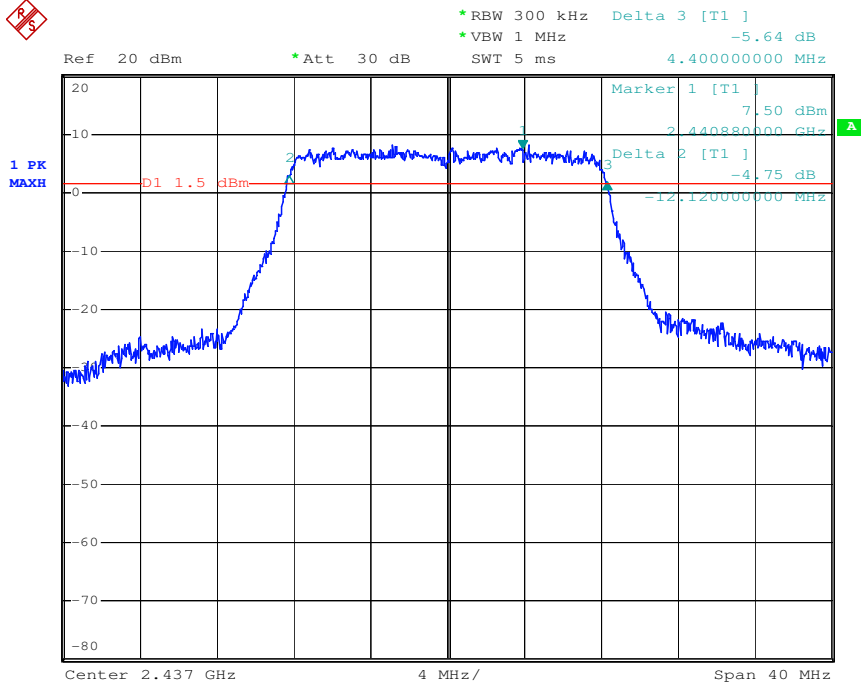

Date: 1.JAN.2000 02:08:33

Highest Channel for Antenna A

Test mode: 802.11g

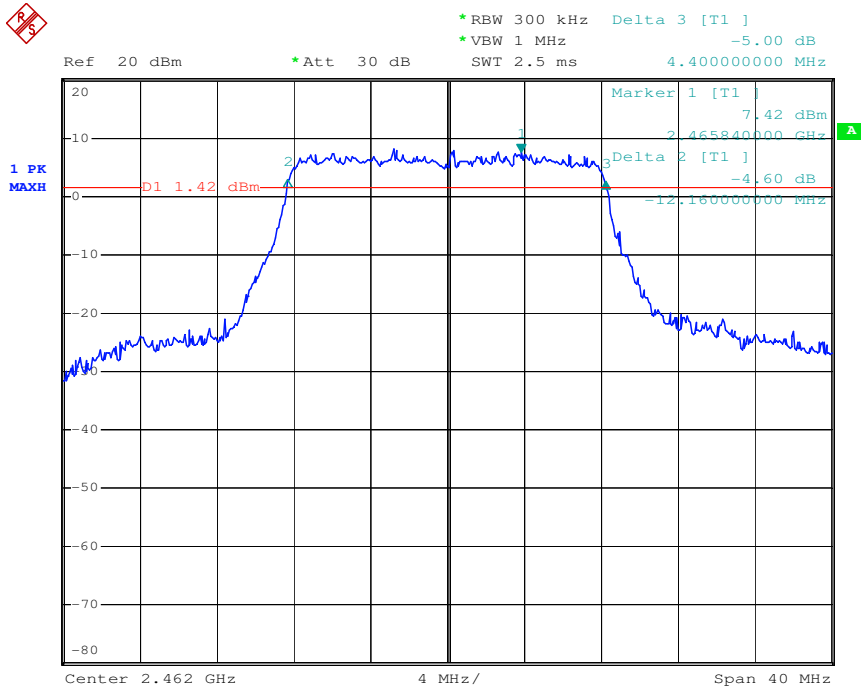

Date: 1.JAN.2000 02:23:09



Lowest Channel for Antenna B

Test mode: 802.11b

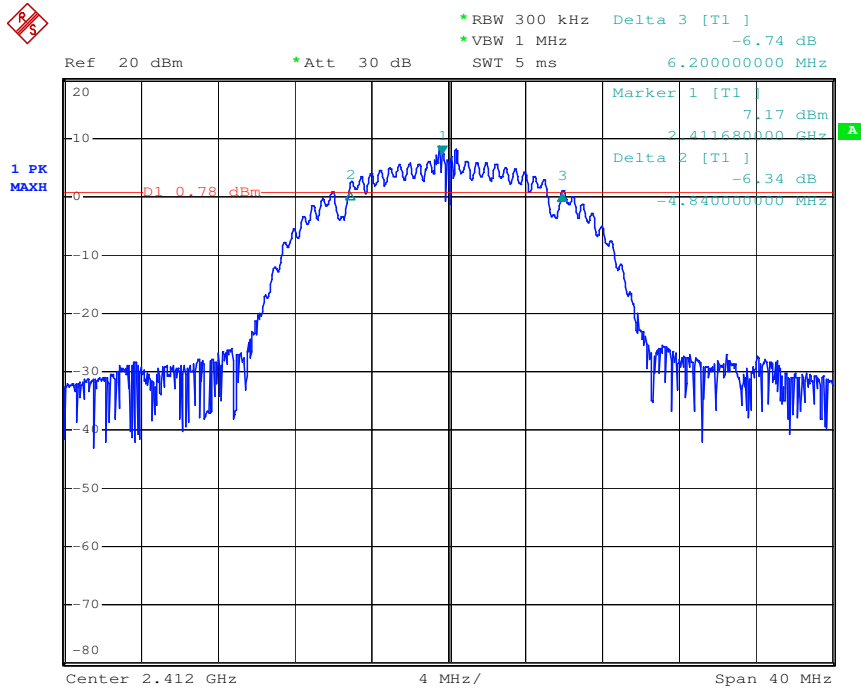

Date: 1.JAN.2000 05:33:49

Middle Channel for Antenna B

Test mode: 802.11b

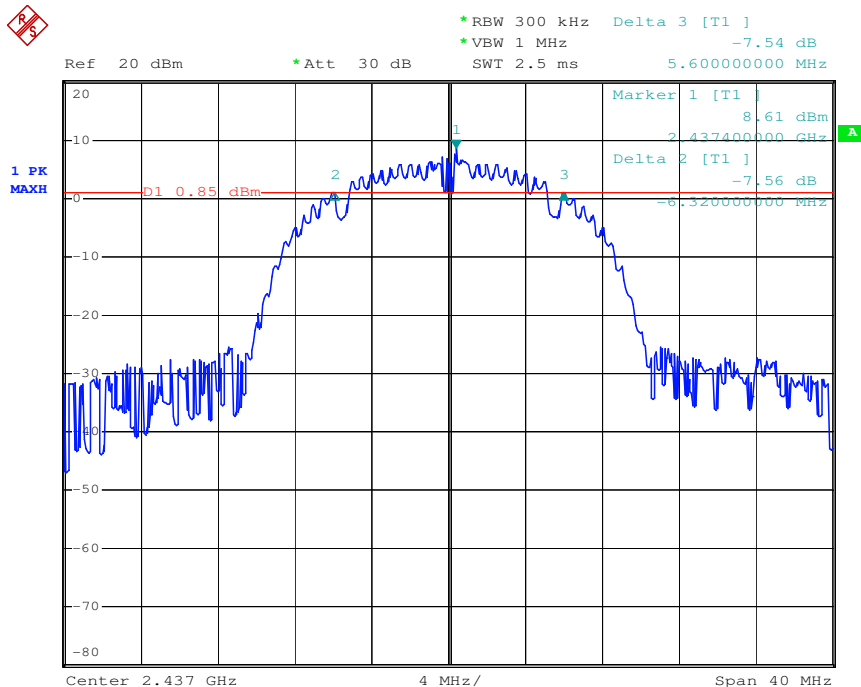

Date: 1.JAN.2000 06:09:30





**Highest Channel for Antenna B**

**Test mode: 802.11b**

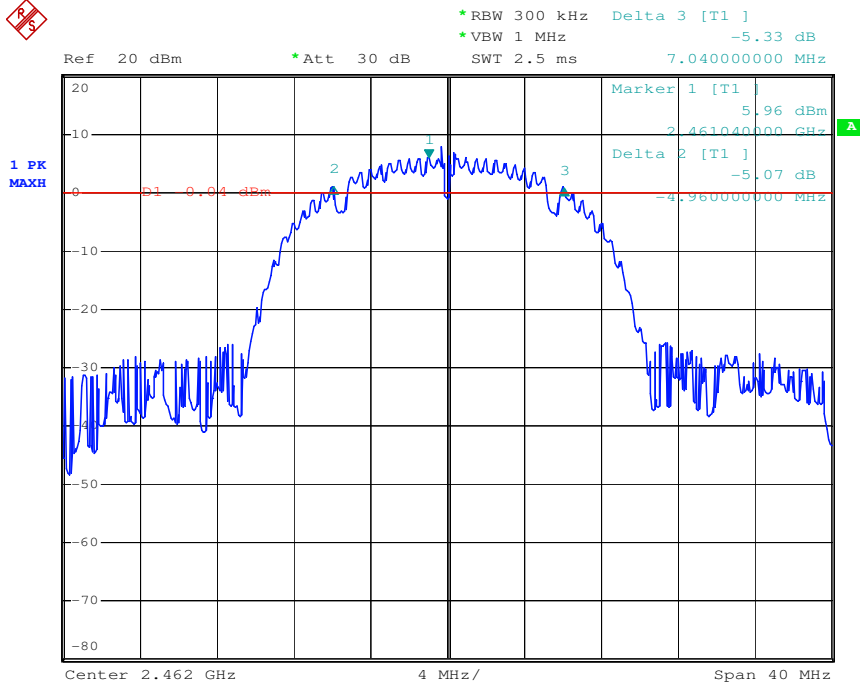

Date: 1.JAN.2000 06:23:58

**Lowest Channel for Antenna B**

**Test mode: 802.11g**

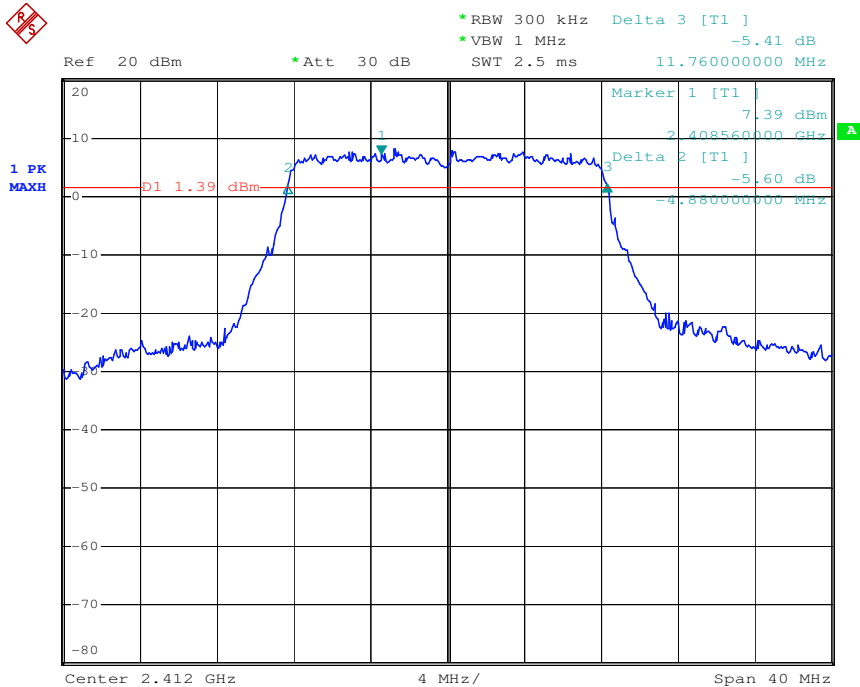

Date: 1.JAN.2000 06:44:20



Middle Channel for Antenna B

Test mode: 802.11g

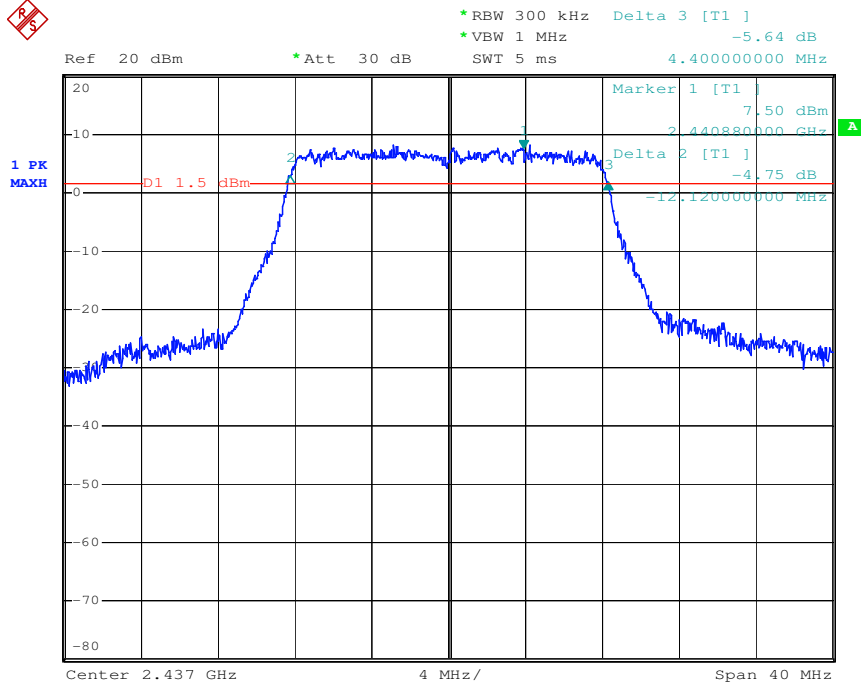

Date: 1.JAN.2000 02:08:33

Highest Channel for Antenna B

Test mode: 802.11g

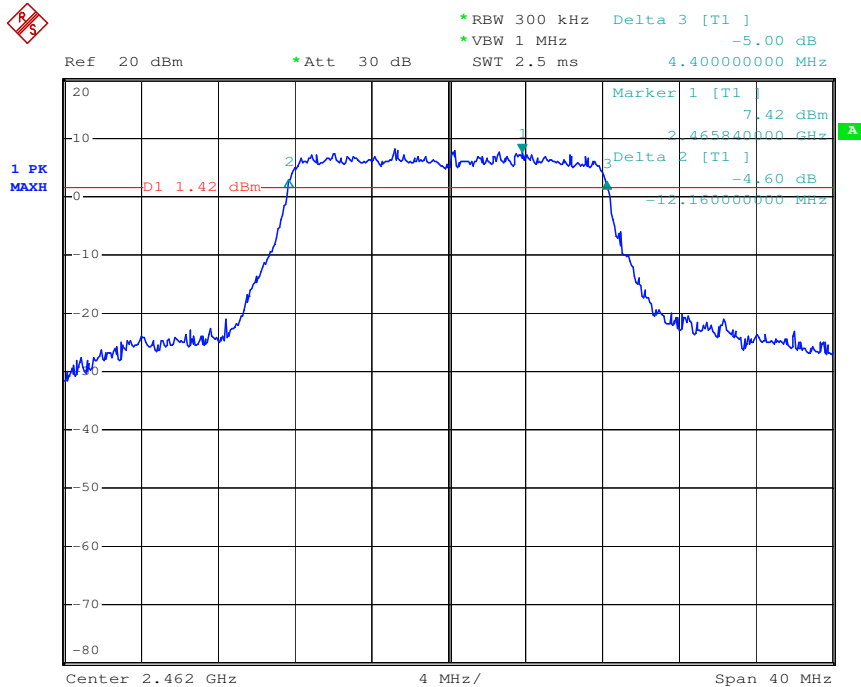

Date: 1.JAN.2000 02:23:09

## 6.5 Peak Output Power Measurement

**Test Requirement:** FCC Part 15 15.247(a)(2),(b)  
**Test date** September 06, 2012  
**Standard Applicable:** According to section 15.247(a)(2),(b)  
 (3) For systems using digital modulation in the 902-928 MHz, 2400-2483.5 MHz, and 5725-5850 MHz bands: 1 Watt. As an alternative to a peak power measurement, compliance with the one Watt limit can be based on a measurement of the maximum conducted output power. Maximum Conducted Output Power is defined as the total transmit power delivered to all antennas and antenna elements averaged across all symbols in the signaling alphabet when the transmitter is operating at its maximum power control level. Power must be summed across all antennas and antenna elements. The average must not include any time intervals during which the transmitter is off or is transmitting at a reduced power level. If multiple modes of operation are possible (e.g., alternative modulation methods), the maximum conducted output power is the highest total transmit power occurring in any mode.

### Measurement Procedure

- Measure the EUT 6dB bandwidth of the emission. reference section 5.3.3 6dB bandwidth results.
- When the analyzer RBW is not large enough, the analyzer band power function can be used,
- Set the RBW=1MHz(the analyzer maximum available), VBW=3MHz, band limits greater than 26dB bandwidth.
- Turn averaging off, set sweep to automatic, the span just large enough to capture the emission.
- Use peak detector on max hold.  
Record the measured channel power.

### Measurement Result:

#### Test Data for Antenna A

Test mode: 802.11b

CH	Frequency (MHz)	Reading Peak Power (dBm)	Cable Loss (dB)	Output Peak Power (dBm)	Output Peak Power (mW)	Peak Power Limit (dBm)	Result
Low	2412	19.09	0.6	21.69	147.57	30	PASS
Mid	2437	19.42	0.6	22.02	159.22	30	PASS
High	2462	18.99	0.6	21.59	144.21	30	PASS

#### Test Data for Antenna A

Test mode: 802.11g

CH	Frequency (MHz)	Reading Peak Power (dBm)	Cable Loss (dB)	Output Peak Power (dBm)	Output Peak Power (mW)	Peak Power Limit (dBm)	Result
Low	2412	23.20	0.6	25.80	380.19	30	PASS
Mid	2437	23.96	0.6	26.56	452.90	30	PASS
High	2462	23.78	0.6	26.38	434.51	30	PASS



Test Data for Antenna B

Test mode: 802.11b

CH	Frequency (MHz)	Reading Peak Power (dBm)	Cable Loss (dB)	Output Peak Power (dBm)	Output Peak Power (mW)	Peak Power Limit (dBm)	Result
Low	2412	18.93	0.6	21.53	142.23	30	PASS
Mid	2437	19.26	0.6	21.86	153.46	30	PASS
High	2462	19.19	0.6	21.79	151.00	30	PASS

Test Data for Antenna B

Test mode: 802.11g

CH	Frequency (MHz)	Reading Peak Power (dBm)	Cable Loss (dB)	Output Peak Power (dBm)	Output Peak Power (mW)	Peak Power Limit (dBm)	Result
Low	2412	23.65	0.6	26.25	421.70	30	PASS
Mid	2437	23.74	0.6	26.34	430.53	30	PASS
High	2462	23.75	0.6	26.35	431.52	30	PASS

Low Channel for Antenna A

Test mode: 802.11b

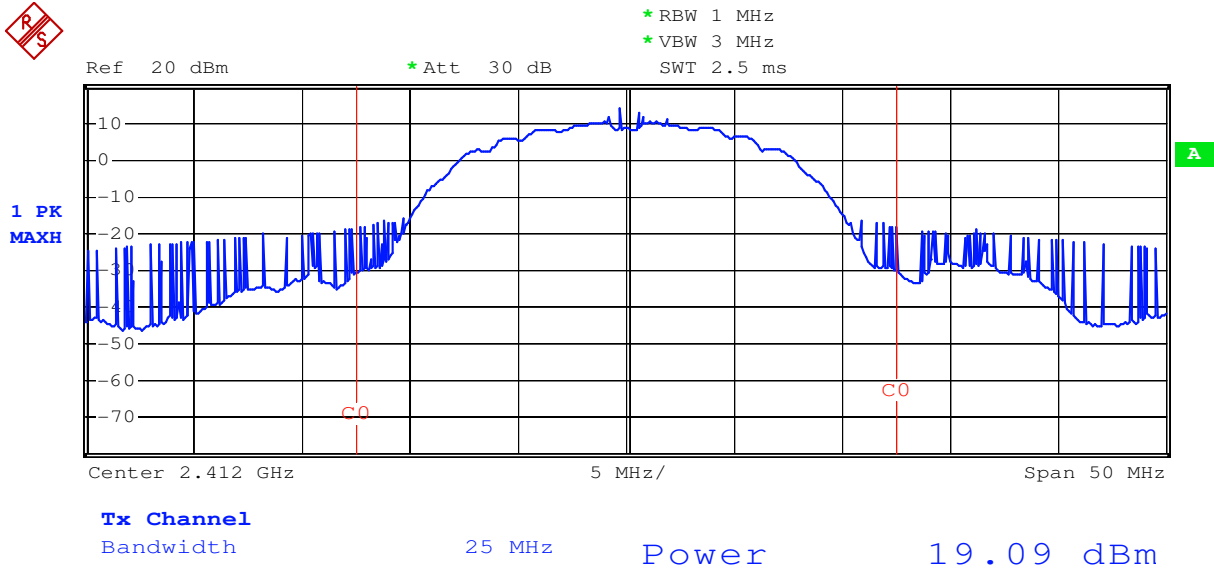



Mid Channel for Antenna A

Test mode: 802.11b

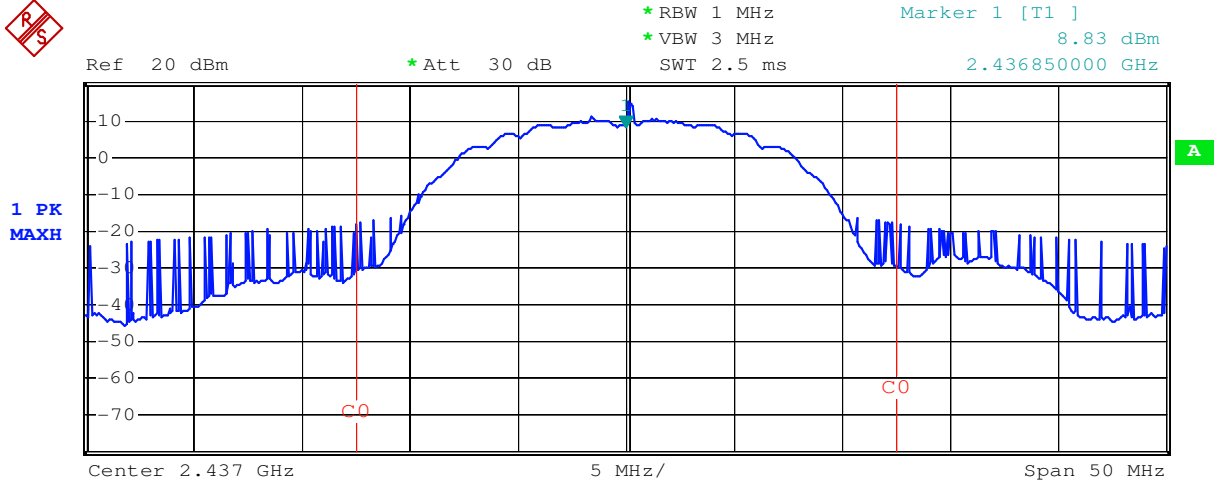

**Tx Channel**  
Bandwidth 25 MHz Power 19.42 dBm

High Channel for Antenna A

Test mode: 802.11b

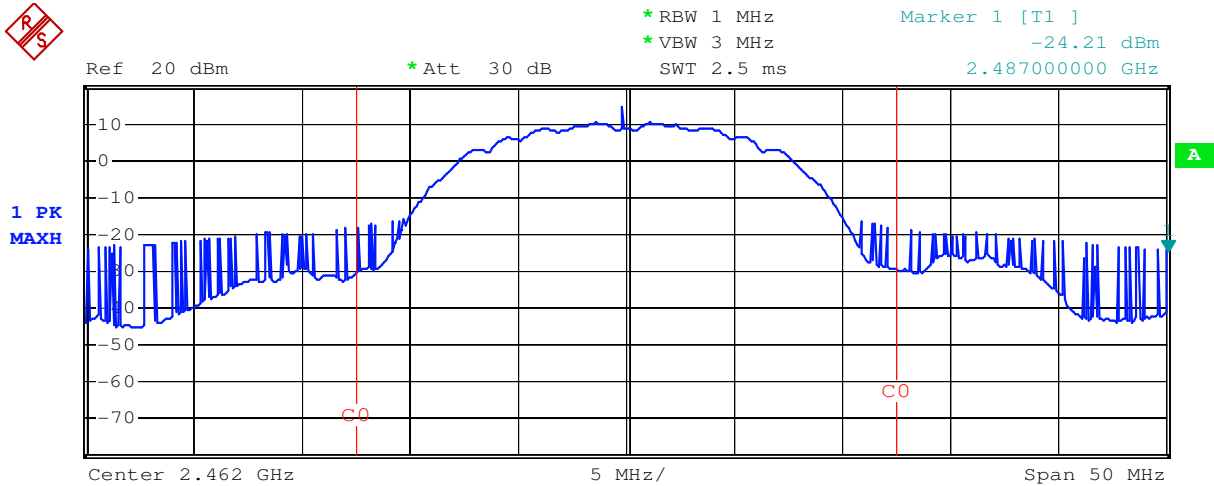

**Tx Channel**  
Bandwidth 25 MHz Power 18.99 dBm



**Low Channel for Antenna A**

**Test mode: 802.11g**



\* RBW 1 MHz  
\* VBW 3 MHz  
SWT 2.5 ms  
Marker 1 [T1]  
10.48 dBm  
2.412150000 GHz

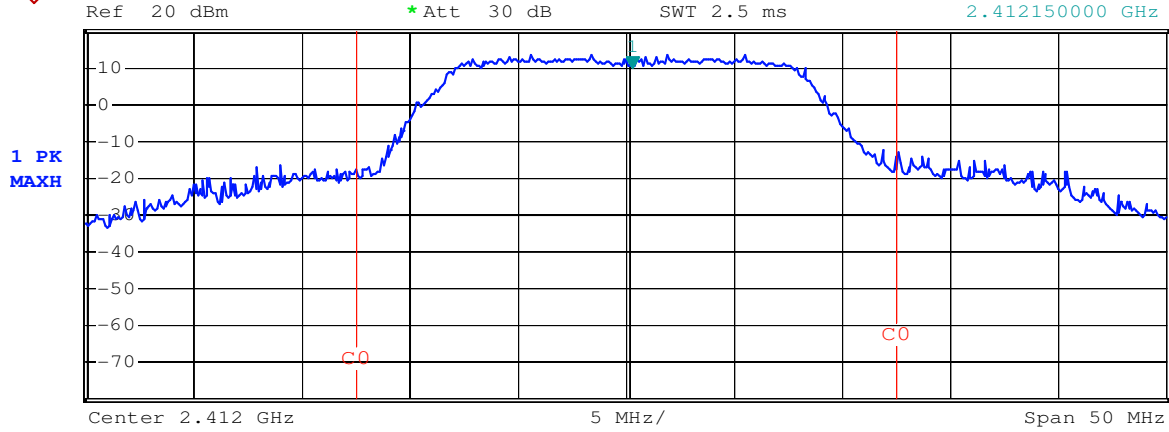

**Tx Channel**  
Bandwidth 25 MHz Power 23.20 dBm

**Mid Channel for Antenna A**

**Test mode: 802.11g**



\* RBW 1 MHz  
\* VBW 3 MHz  
SWT 2.5 ms  
Marker 1 [T1]  
12.29 dBm  
2.436850000 GHz

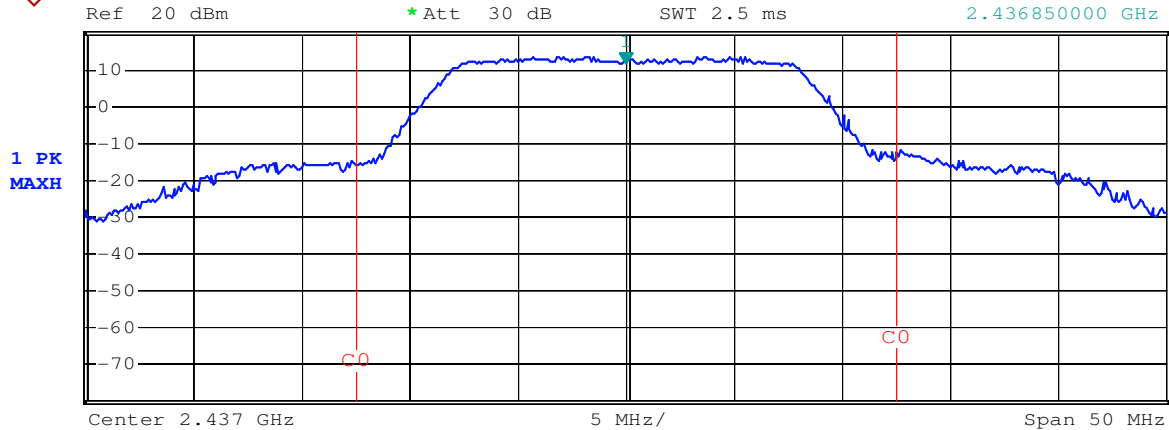

**Tx Channel**  
Bandwidth 25 MHz Power 23.96 dBm



High Channel for Antenna A

Test mode: 802.11g

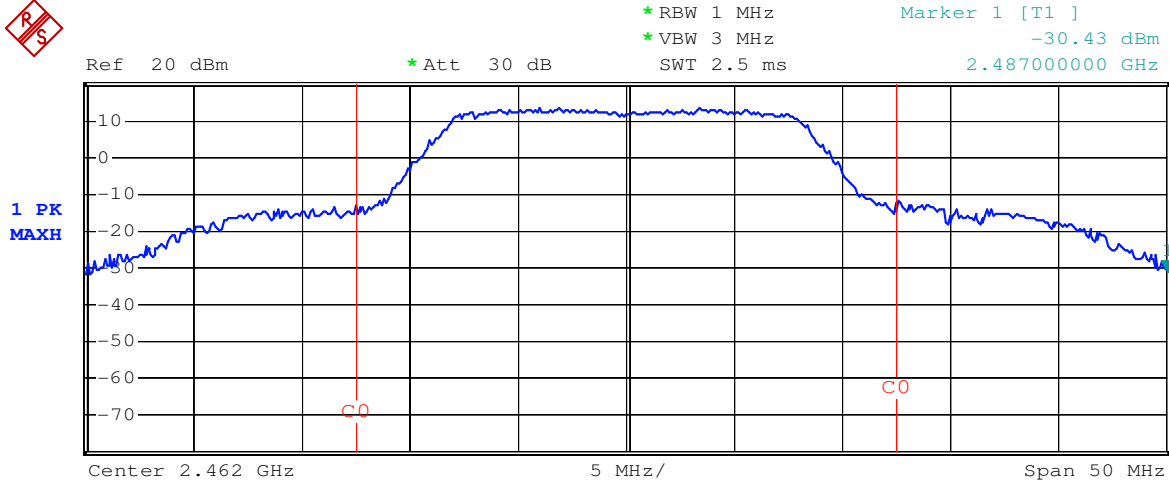

**Tx Channel**  
 Bandwidth 25 MHz      Power 23.78 dBm

Low Channel for Antenna B

Test mode: 802.11b

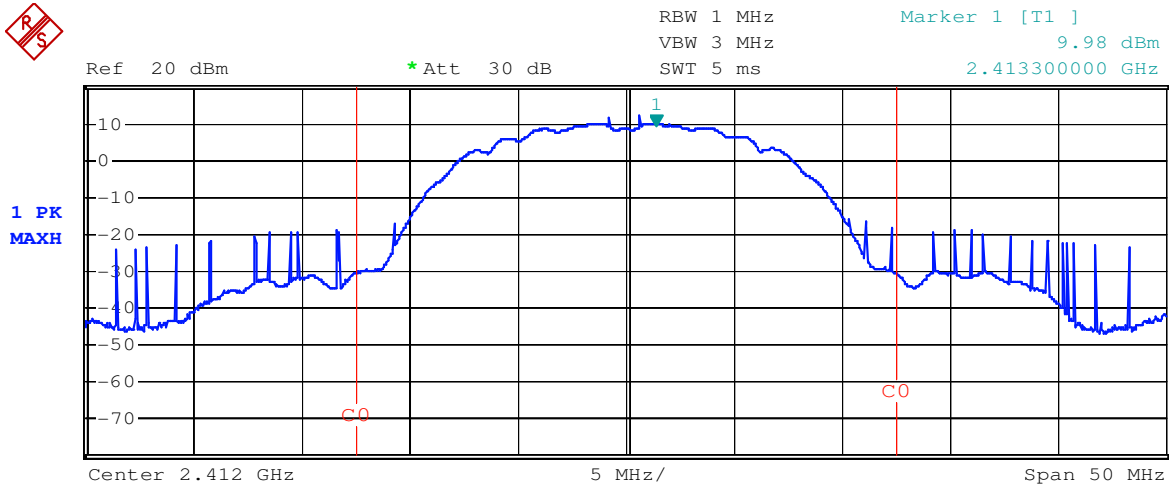

**Tx Channel**  
 Bandwidth 25 MHz      Power 18.93 dBm

**Mid Channel for Antenna B**

**Test mode: 802.11b**



\* RBW 1 MHz  
\* VBW 3 MHz  
SWT 5 ms  
Marker 1 [T1]  
8.71 dBm  
2.436850000 GHz

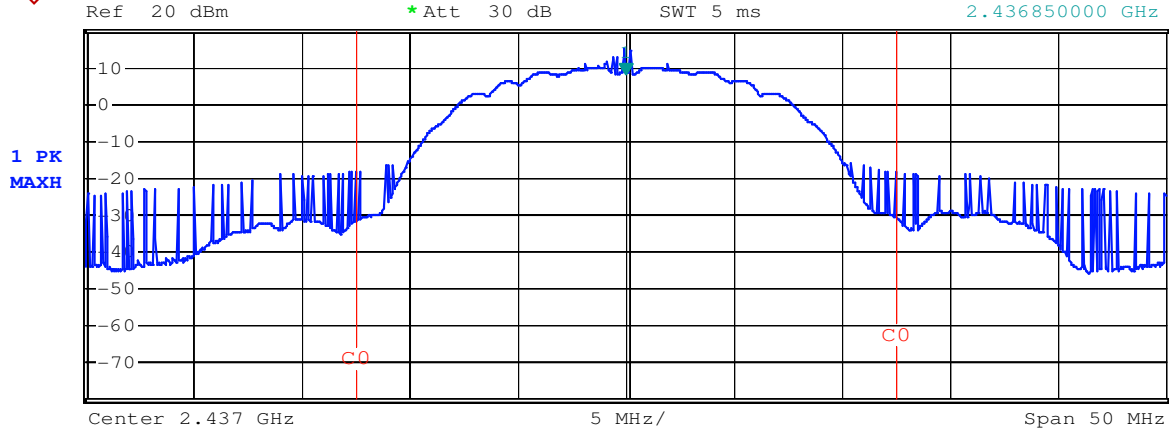

**Tx Channel**  
Bandwidth 25 MHz Power 19.26 dBm

**High Channel for Antenna B**

**Test mode: 802.11b**



\* RBW 1 MHz  
\* VBW 3 MHz  
SWT 5 ms  
Marker 1 [T1]  
8.43 dBm  
2.461850000 GHz

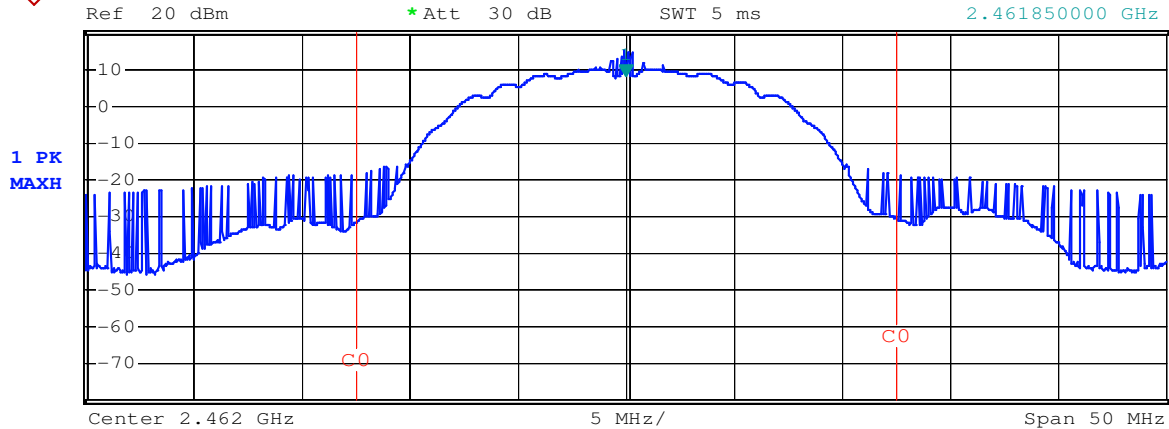

**Tx Channel**  
Bandwidth 25 MHz Power 19.19 dBm





Low Channel for Antenna B

Test mode: 802.11g



\* RBW 1 MHz  
\* VBW 3 MHz  
SWT 5 ms  
Marker 1 [T1 ]  
12.27 dBm  
2.412150000 GHz

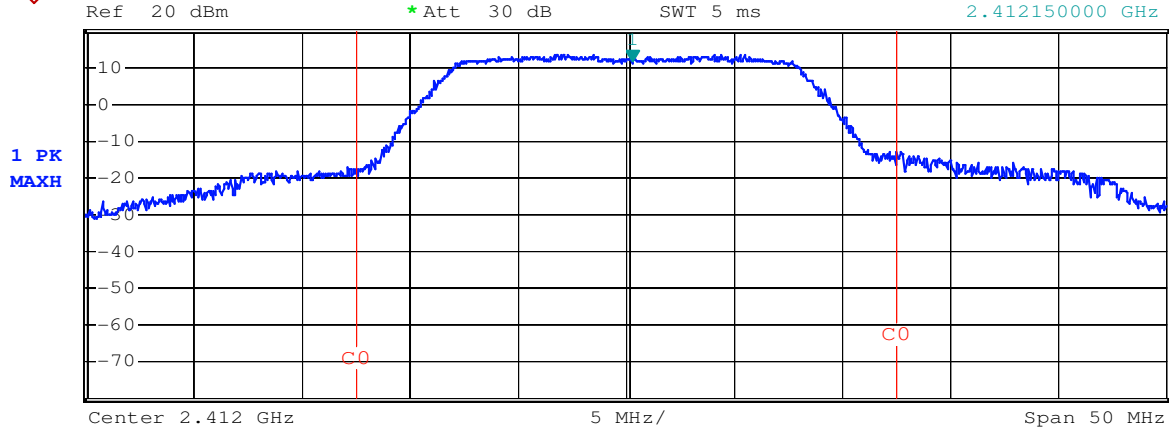

**Tx Channel**  
Bandwidth 25 MHz Power 23.65 dBm

Mid Channel for Antenna B

Test mode: 802.11g



\* RBW 1 MHz  
\* VBW 3 MHz  
SWT 5 ms

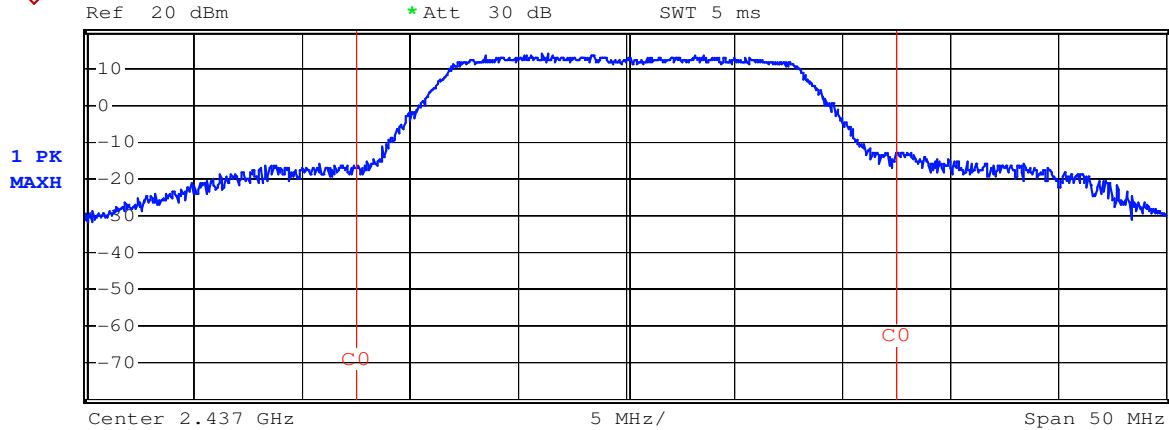

**Tx Channel**  
Bandwidth 25 MHz Power 23.74 dBm



High Channel for Antenna B

Test mode: 802.11g

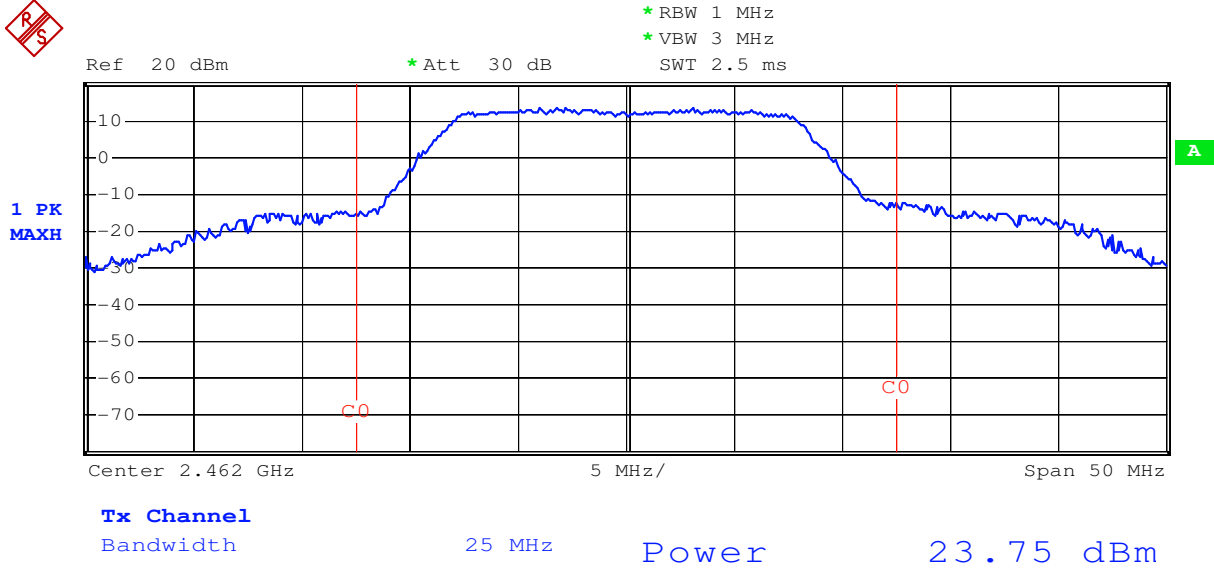

## 6.6 Radiated Emission Band Edge

**Test Requirement:** FCC Part15 247(c)  
**Test date:** September 17. 2012  
**Standard Applicable:** According to section 15.247(c),in any 100KHz bandwidth outside the frequency bands in which the spread spectrum intentional radiator in operating,the radio frequency power that is produced by the intentional radiator shall be at least 20dB below that in the 100KHz bandwidth within the band that contains the highest level of the desired power,In addition,radiated emissions which fall in the restricted bands,as defined in section 15.205(a),must also comply with the radiated emission limits specified in 15.209(a).

**Measurement Distance:** 3m (Semi-Anechoic Chamber)

**Limit:** 40.0 dB $\mu$ V/m between 30MHz & 88MHz;  
 43.5 dB $\mu$ V/m between 88MHz & 216MHz;  
 46.0 dB $\mu$ V/m between 216MHz & 960MHz;  
 AV 54.0 dB $\mu$ V/m PK 74.0dB $\mu$ V/m above 960MHz.

**Measurement Procedure:** The EUT was setup according to ANSI 63.10,2009 for compliance to FCC 47 CFR 15.247 requirements.The EUT is placed on a turn table which is 0.8 m above ground.The turn table is rotated 360 degrees to determine to the position of the maximum emission level.The EUT was positioned such that the distance from antenna to the EUT was 3 mentsers.The antenna is scanned from 1 meter to 4 meters to find out the maximum emission level

This is repeated for both horizontal and vertical polarization of the antenna.In order to find the maximum emission,all of the interface cables were manipulated according to ANSIC 63.10:2009 on radiated measurement.

Spectrum analyzer parameters setting as shown below:

(a) PEAK: RBW=VBW=1MHz / Sweep=AUTO

(b) AVERAGE: RBW=1MHz / VBW=10Hz / Sweep=AUTO

### Radiated Emission Test Set-up Frequency Over 1GHz

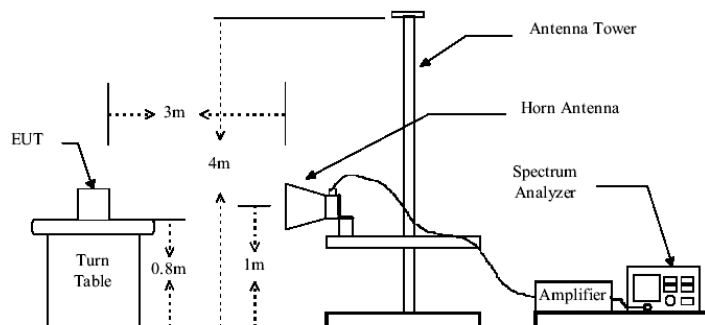

The field strength is calculated by adding the Antenna Factor, Preamplifier Factor & Cable Factor. The basic equation with a sample calculation is as follows:

Final Test Level = Receiver Reading + Antenna Factor + Cable Factor - Preamplifier Factor



**Radiated Bandedge Measurement Result:  
CH Low 2412MHz Radiated Bandedge Antenna A for 802.11 b  
Horizontal, Peak Detector:**

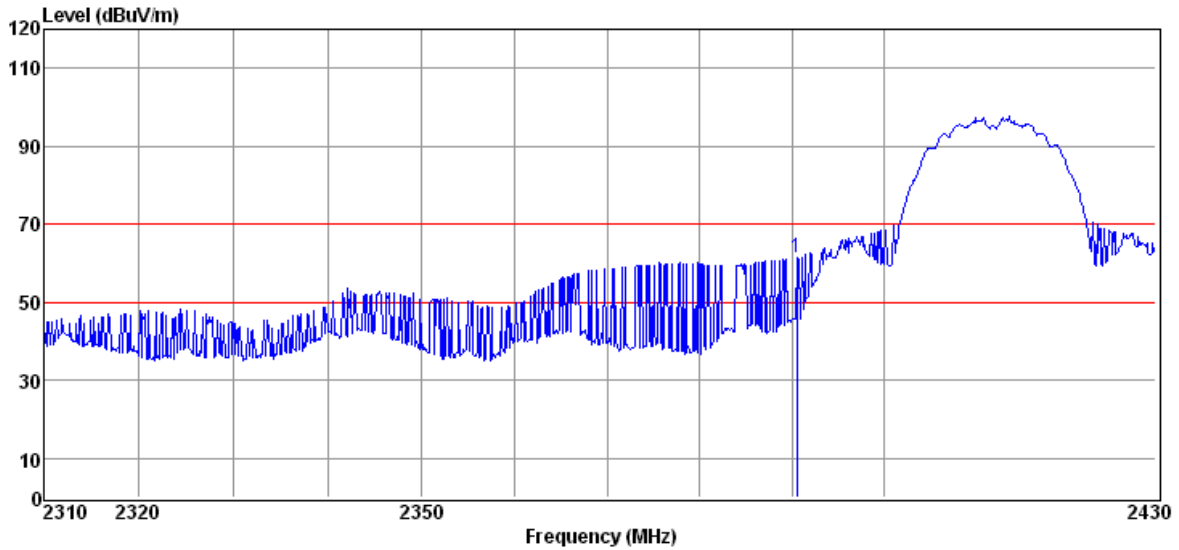

Frequency (MHz)	Peak Reading (dBuV)	Antenna Factor (dB/m)	PreAmp (dB)	Cable Loss (dB)	Peak Level (dBuV/m)	Peak Limit (dBuV/m)	Margin (dB)
2390.57	69.54	27.07	42.46	7.33	61.48	74.00	12.52

**Horizontal, Averager Detector:**

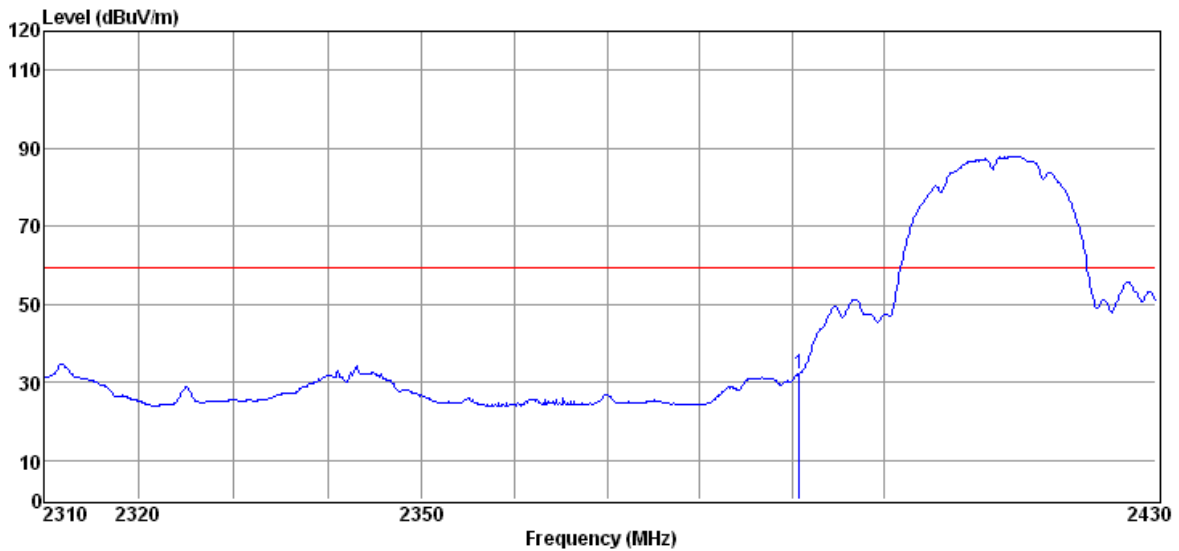

Frequency (MHz)	Reading (dBuV)	Antenna Factor (dB/m)	PreAmp (dB)	Cable Loss (dB)	Averager Level (dBuV/m)	Averager Limit (dBuV/m)	Margin (dB)
2390.82	40.30	27.07	42.46	7.33	32.24	54.00	21.76

**CH Low 2412MHz Radiated Bandedge Antenna A for 802.11 b  
Vertical, Peak Detector:**

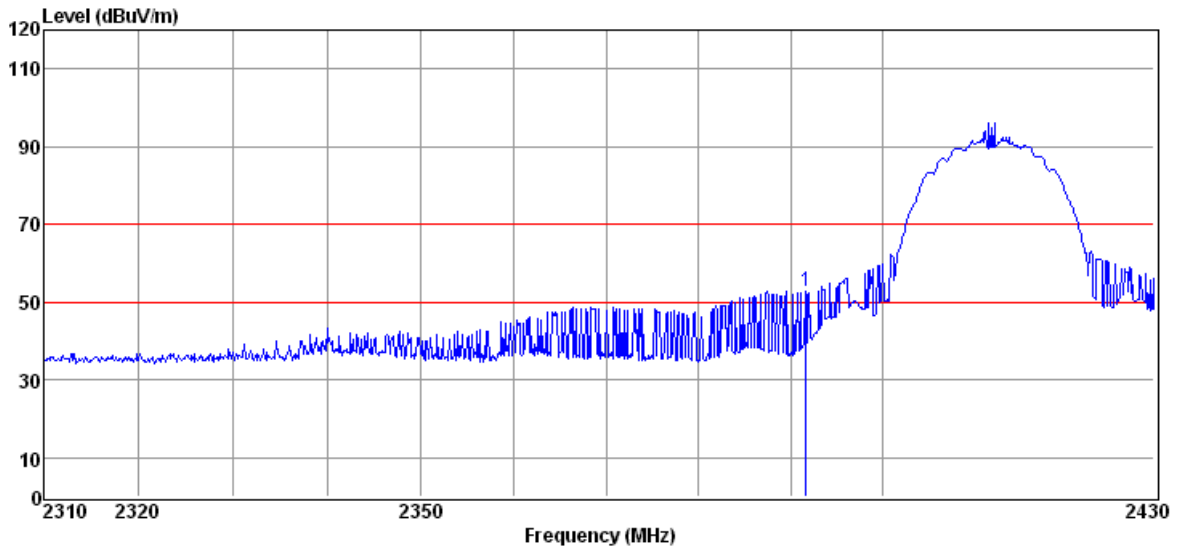

Frequency (MHz)	Peak Reading (dBuV)	Antenna Factor (dB/m)	PreAmp (dB)	Cable Loss (dB)	Peak Level (dBuV/m)	Peak Limit (dBuV/m)	Margin (dB)
2391.66	60.67	27.07	42.46	7.33	52.61	74.00	21.39

**Vertical, Averager Detector:**

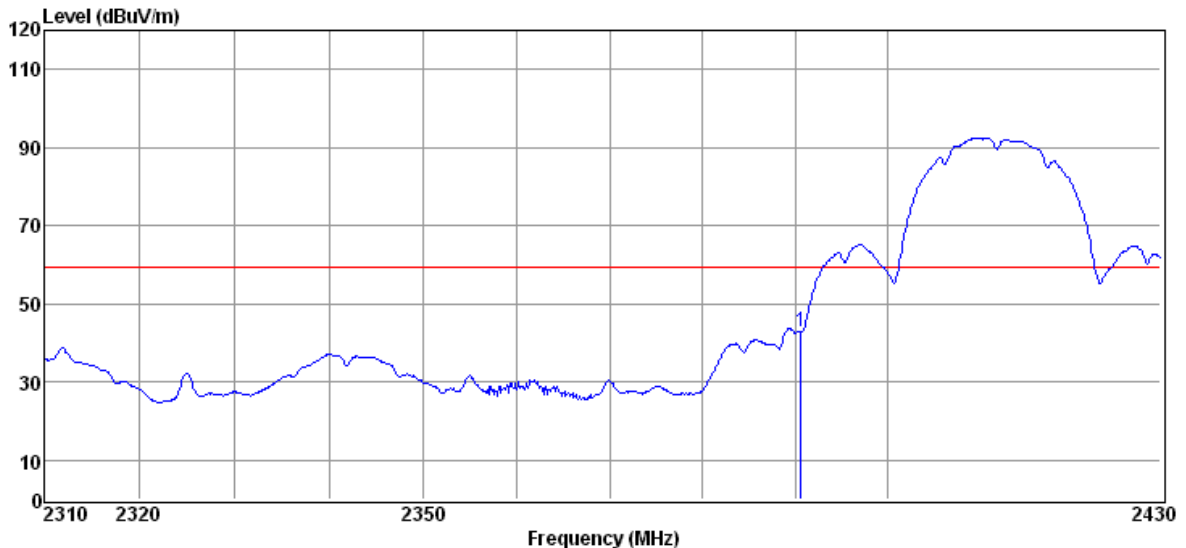

Frequency (MHz)	Reading (dBuV)	Antenna Factor (dB/m)	PreAmp (dB)	Cable Loss (dB)	Averager Level (dBuV/m)	Averager Limit (dBuV/m)	Margin (dB)
2390.70	50.92	27.07	42.46	7.33	42.86	54.00	11.14

**CH High 2462MHz Radiated Bandedge Antenna A for 802.11 b  
Horizontal, Peak Detector:**

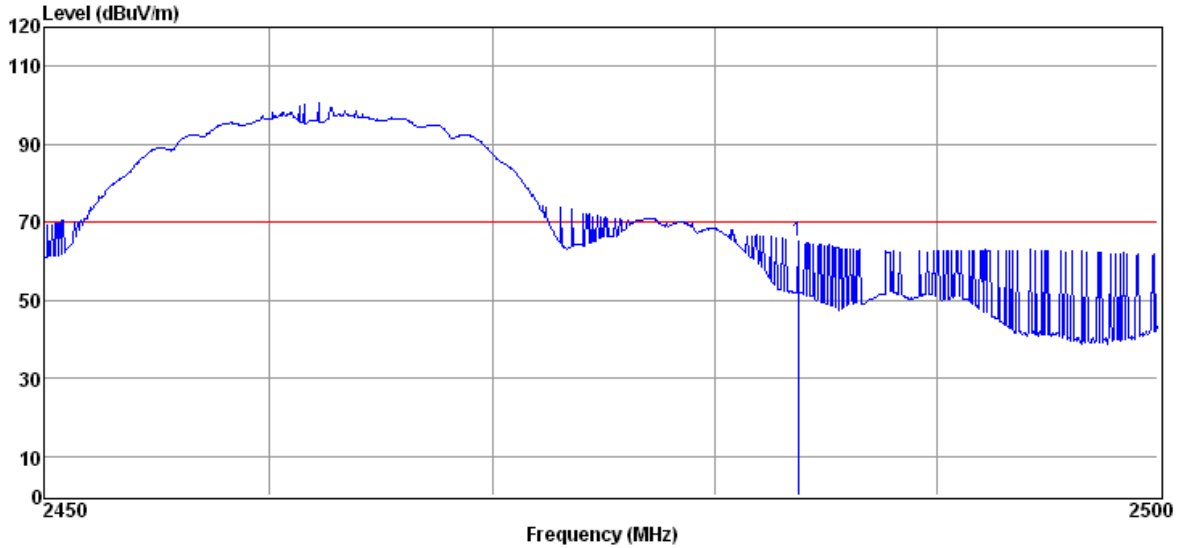

Frequency (MHz)	Peak Reading (dBuV)	Antenna Factor (dB/m)	PreAmp (dB)	Cable Loss (dB)	Peak Level (dBuV/m)	Peak Limit (dBuV/m)	Margin (dB)
2483.34	73.18	27.35	42.49	7.31	65.35	74.00	8.65

**Horizontal, Averager Detector:**

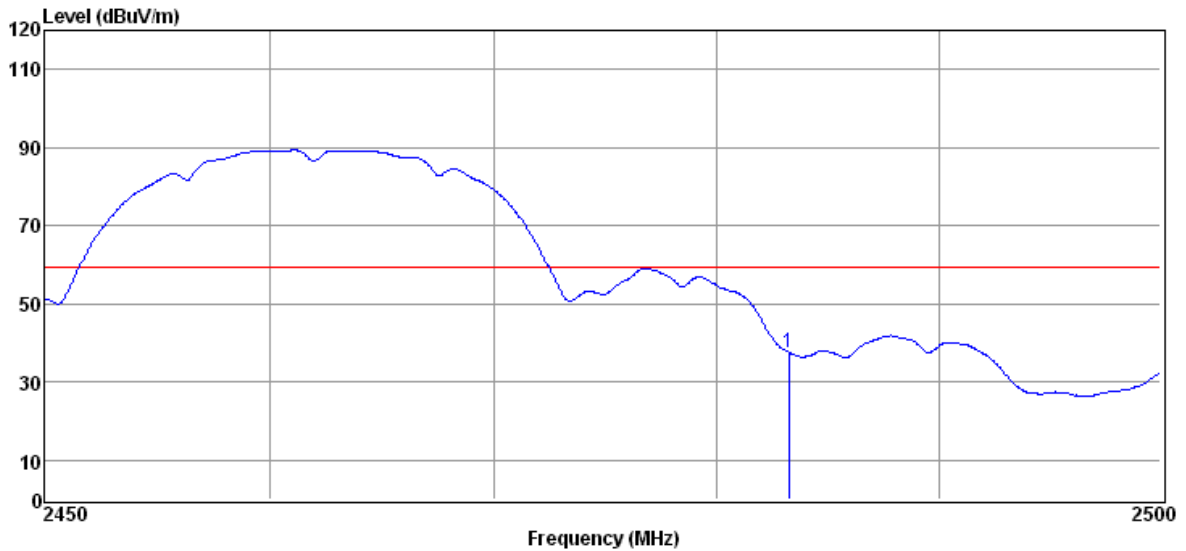

Frequency (MHz)	Reading (dBuV)	Antenna Factor (dB/m)	PreAmp (dB)	Cable Loss (dB)	Averager Level (dBuV/m)	Averager Limit (dBuV/m)	Margin (dB)
2483.24	45.43	27.35	42.49	7.31	37.60	54.00	16.40

**CH High 2462MHz Radiated Bandedge Antenna A for 802.11 b  
Vertical, Peak Detector:**

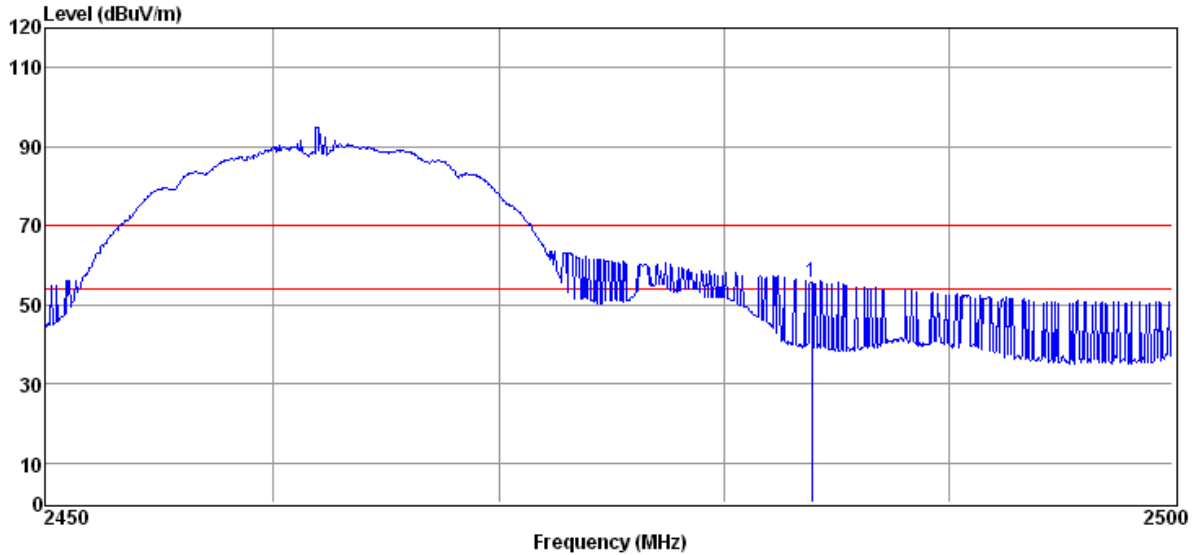

Frequency (MHz)	Peak Reading (dBuV)	Antenna Factor (dB/m)	PreAmp (dB)	Cable Loss (dB)	Peak Level (dBuV/m)	Peak Limit (dBuV/m)	Margin (dB)
2483.42	63.59	27.35	42.49	7.31	55.76	74.00	18.24

**Vertical, Averager Detector:**

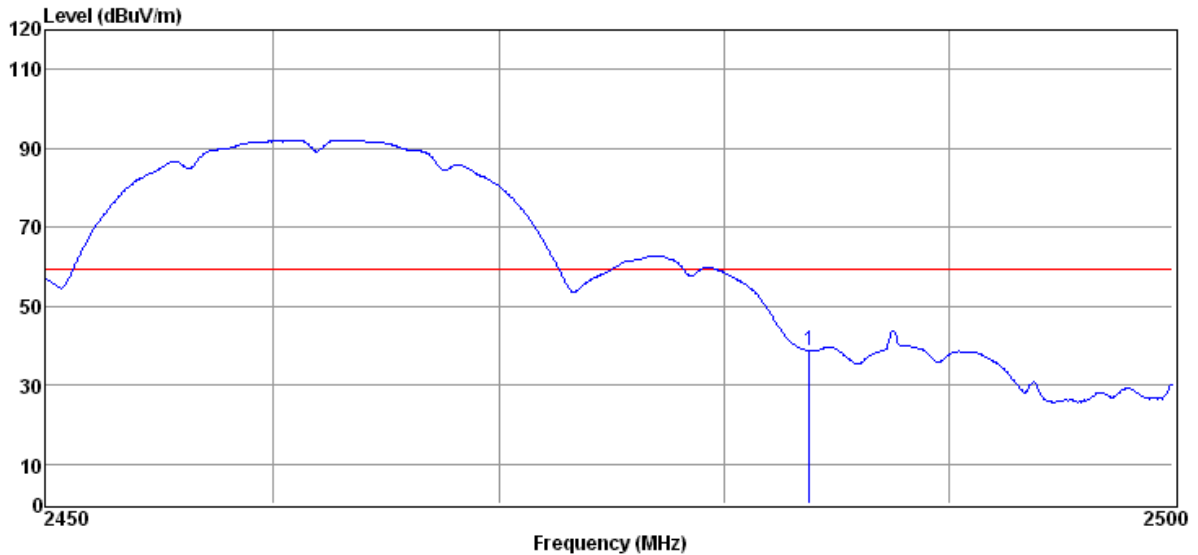

Frequency (MHz)	Reading (dBuV)	Antenna Factor (dB/m)	PreAmp (dB)	Cable Loss (dB)	Averager Level (dBuV/m)	Averager Limit (dBuV/m)	Margin (dB)
2483.24	45.43	27.35	42.49	7.31	37.60	54.00	16.40

**CH Low 2412MHz Radiated Bandedge Antenna A for 802.11 g  
Horizontal, Peak Detector:**

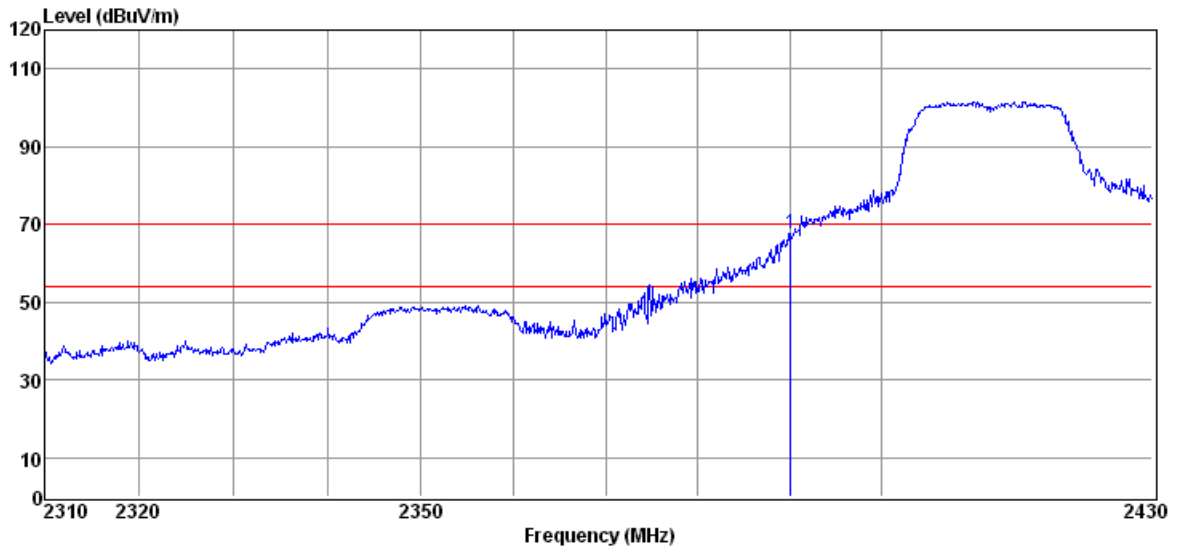

Frequency (MHz)	Reading (dBuV)	Antenna Factor (dB/m)	PreAmp (dB)	Cable Loss (dB)	Peak Level (dBuV/m)	Peak Limit (dBuV/m)	Margin (dB)
2390.49	75.60	27.07	42.46	7.33	67.54	74.00	6.46

**Horizontal, Averager Detector:**

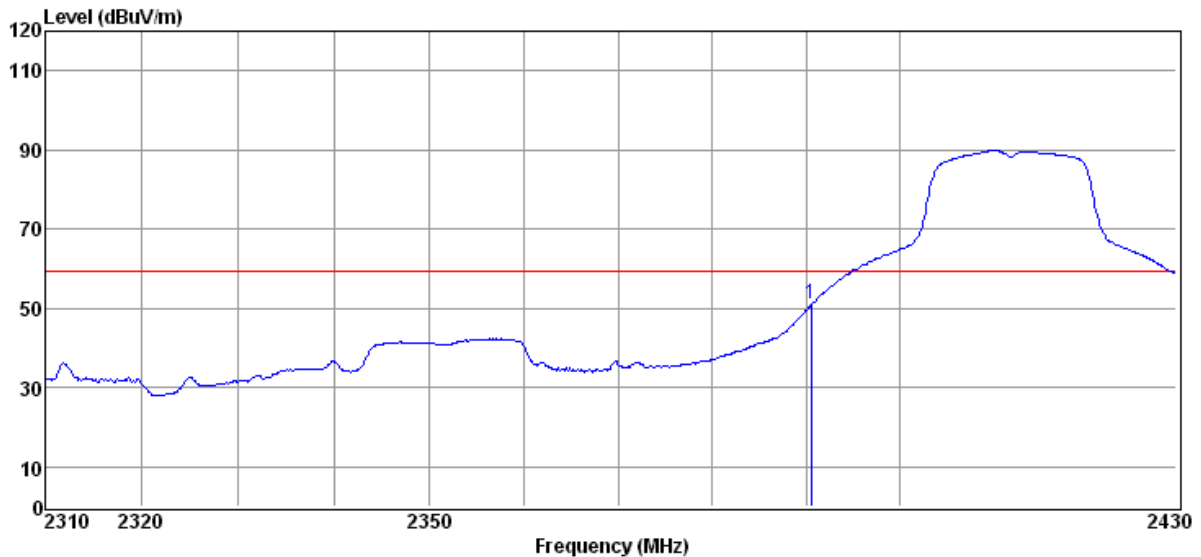

Frequency (MHz)	Reading (dBuV)	Antenna Factor (dB/m)	PreAmp (dB)	Cable Loss (dB)	Averager Level (dBuV/m)	Averager Limit (dBuV/m)	Margin (dB)
2390.57	58.50	27.07	42.46	7.33	50.44	54.00	3.56





**CH Low 2412MHz Radiated Bandedge Antenna A for 802.11 g  
Vertical, Peak Detector:**

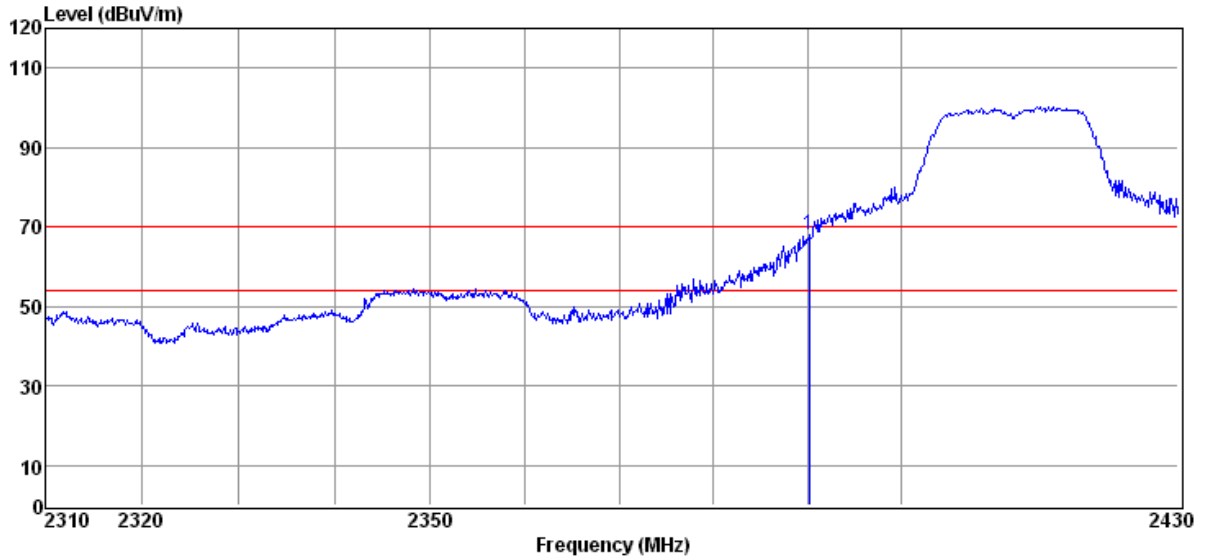

Frequency (MHz)	Reading (dBuV)	Antenna Factor (dB/m)	PreAmp (dB)	Cable Loss (dB)	Peak Level (dBuV/m)	Peak Limit (dBuV/m)	Margin (dB)
2390.21	76.13	27.07	42.46	7.33	68.07	74.00	5.93

**Vertical, Averager Detector:**

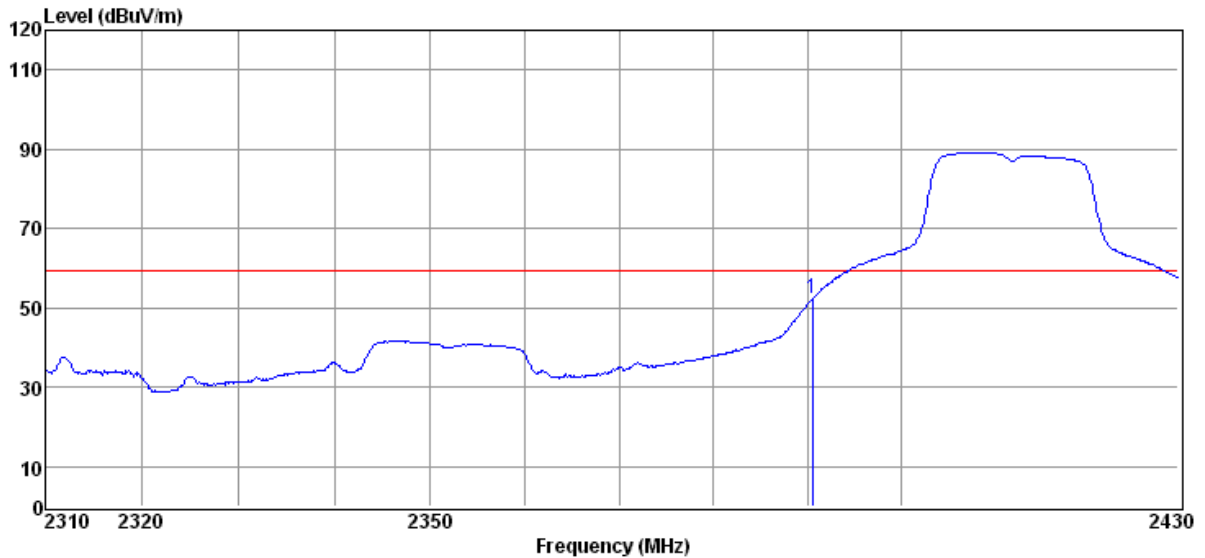

Frequency (MHz)	Reading (dBuV)	Antenna Factor (dB/m)	PreAmp (dB)	Cable Loss (dB)	Averager Level (dBuV/m)	Averager Limit (dBuV/m)	Margin (dB)
2390.57	58.28	27.07	42.46	7.33	50.22	54	3.78



**CH High 2462MHz Radiated Bandedge Antenna A for 802.11 g  
Horizontal, Peak Detector:**

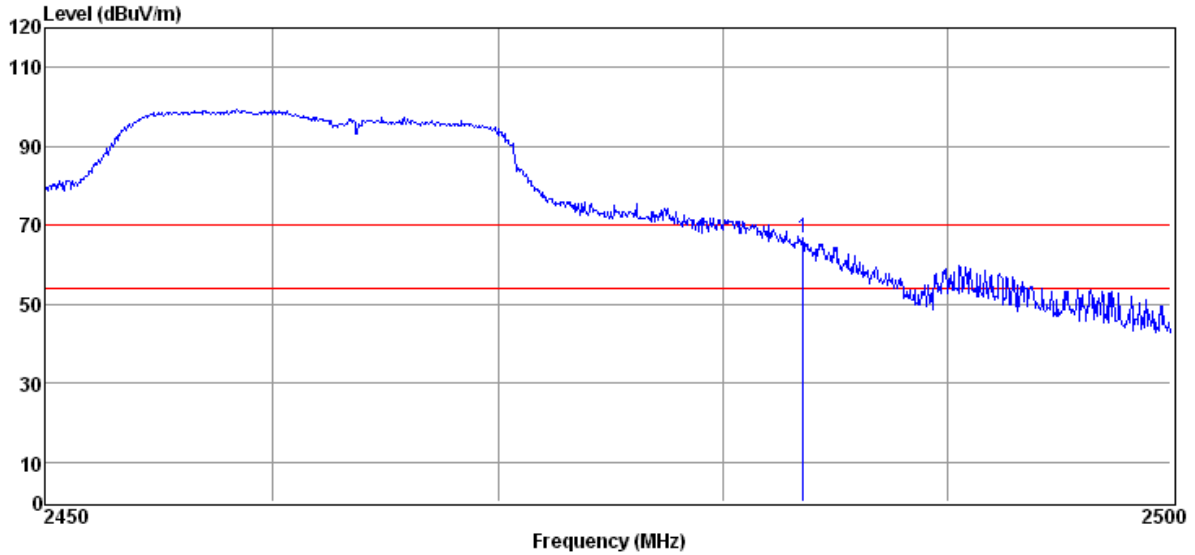

Frequency (MHz)	Reading (dBuV)	Antenna Factor (dB/m)	PreAmp (dB)	Cable Loss (dB)	Peak Level (dBuV/m)	Peak Limit (dBuV/m)	Margin (dB)
2483.39	74.63	27.35	42.49	7.31	66.80	74.00	7.20

**Horizontal, Averager Detector:**

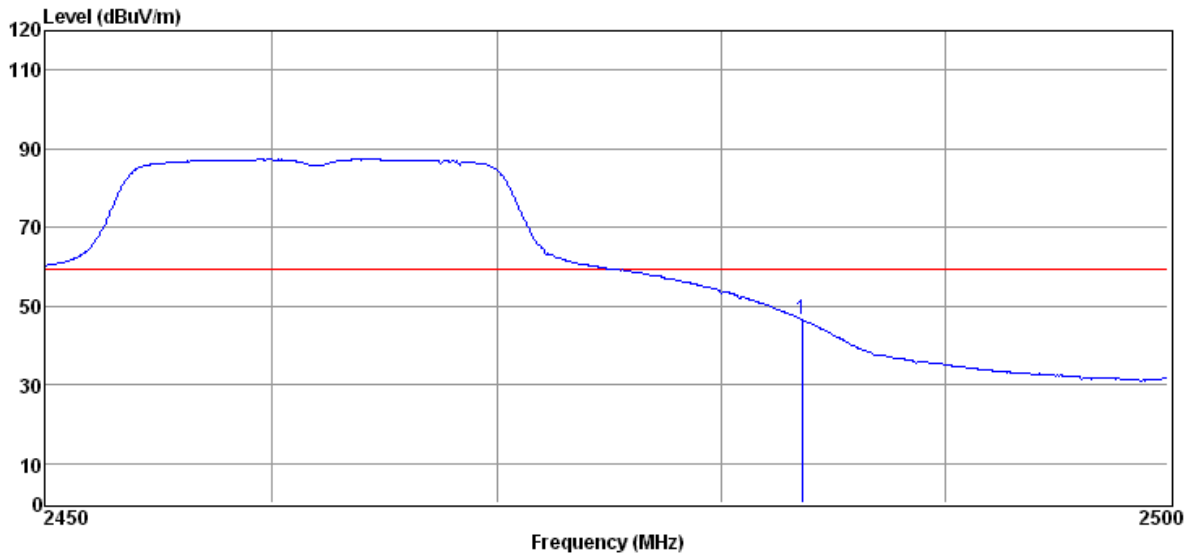

Frequency (MHz)	Reading (dBuV)	Antenna Factor (dB/m)	PreAmp (dB)	Cable Loss (dB)	Averager Level (dBuV/m)	Averager Limit (dBuV/m)	Margin (dB)
2483.48	55.2	27.35	42.49	7.31	47.37	54	6.63



**CH High 2462MHz Radiated Bandedge Antenna A for 802.11 g  
Vertical, Peak Detector:**

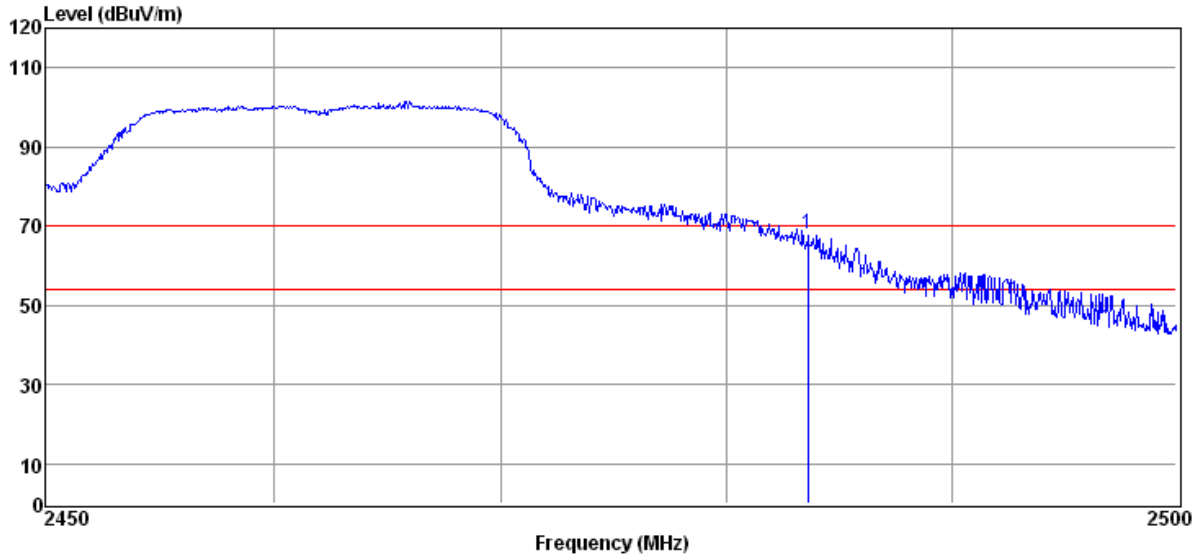

Frequency (MHz)	Reading (dBuV)	Antenna Factor (dB/m)	PreAmp (dB)	Cable Loss (dB)	Peak Level (dBuV/m)	Peak Limit (dBuV/m)	Margin (dB)
2483.39	76.07	27.35	42.49	7.31	68.24	74.00	5.76

**Vertical, Averager Detector:**

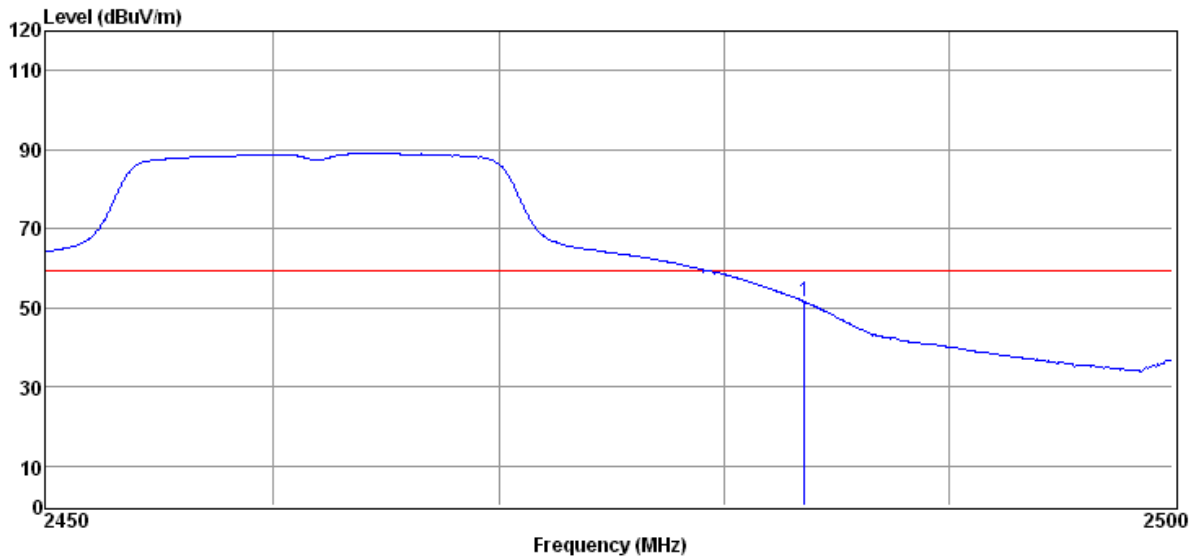

Frequency (MHz)	Reading (dBuV)	Antenna Factor (dB/m)	PreAmp (dB)	Cable Loss (dB)	Averager Level (dBuV/m)	Averager Limit (dBuV/m)	Margin (dB)
2483.41	58.36	27.35	42.49	7.31	50.53	54.00	3.47



**CH Low 2412MHz Radiated Bandedge Antenna B for 802.11 b  
Horizontal, Peak Detector:**

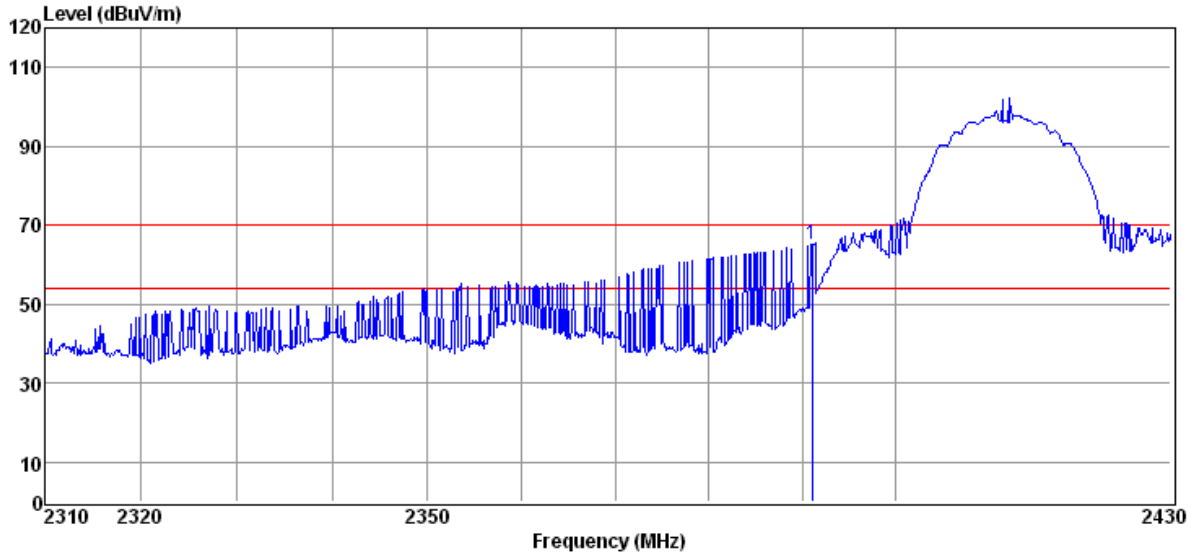

Frequency (MHz)	Reading (dBuV)	Antenna Factor (dB/m)	PreAmp (dB)	Cable Loss (dB)	Peak Level (dBuV/m)	Peak Limit (dBuV/m)	Margin (dB)
2391.06	73.16	27.07	42.46	7.33	65.10	74.00	8.90

**Horizontal, Averager Detector:**

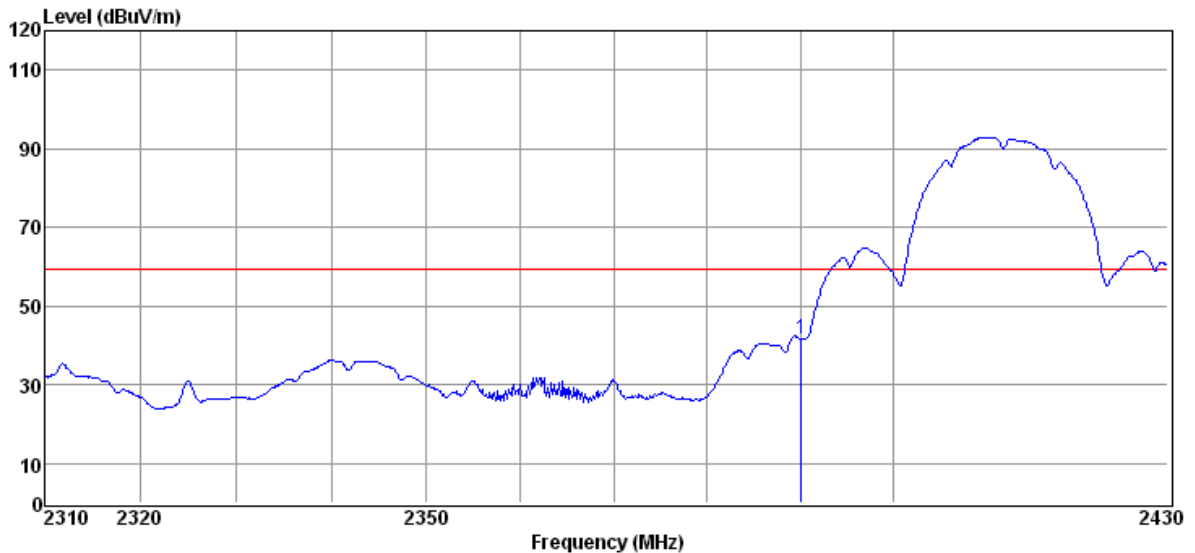

Frequency (MHz)	Reading (dBuV)	Antenna Factor (dB/m)	PreAmp (dB)	Cable Loss (dB)	Averager Level (dBuV/m)	Averager Limit (dBuV/m)	Margin (dB)
2390.29	49.53	27.07	42.46	7.33	41.47	54.00	12.53



**CH Low 2412MHz Radiated Bandedge Antenna B for 802.11 b**  
**Vertical, Peak Detector:**

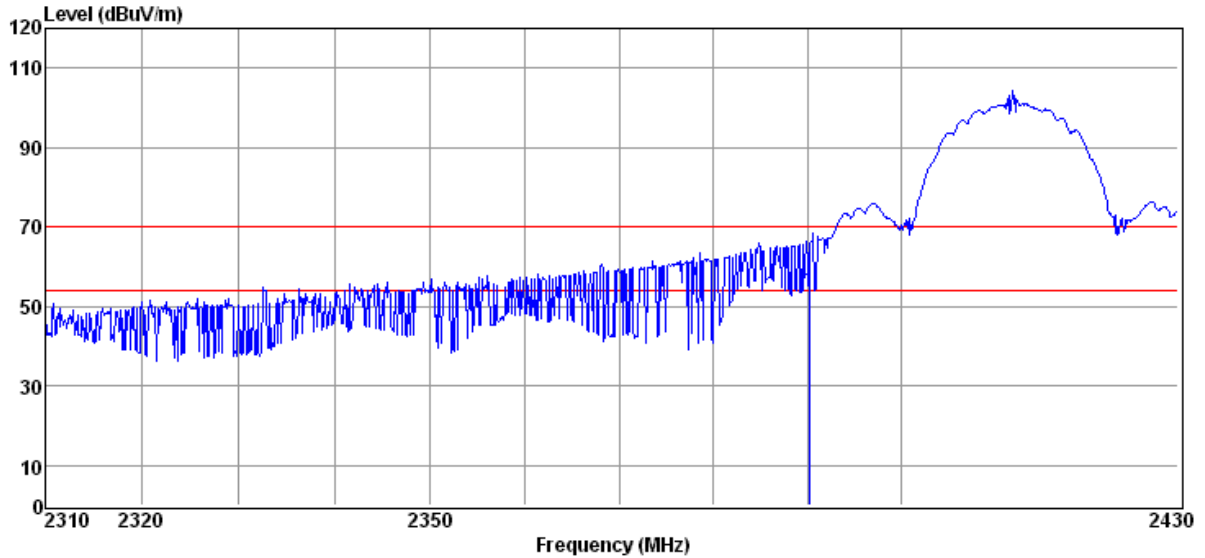

Frequency (MHz)	Reading (dBuV)	Antenna Factor (dB/m)	PreAmp (dB)	Cable Loss (dB)	Peak Level (dBuV/m)	Peak Limit (dBuV/m)	Margin (dB)
2390.21	61.60	27.07	42.46	7.33	53.54	74.00	20.46

**Vertical, Averager Detector:**

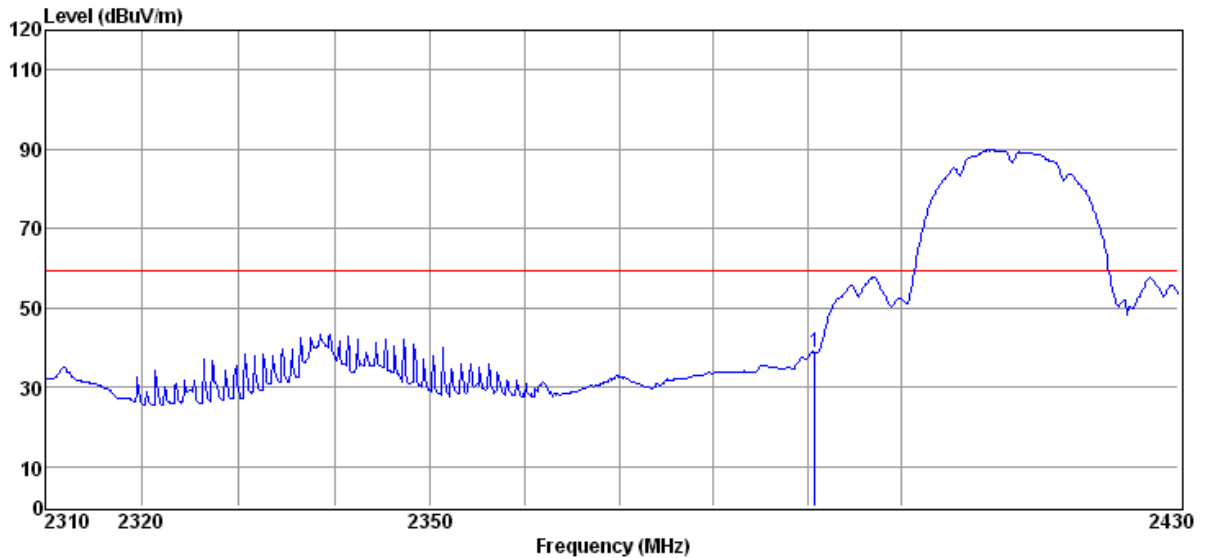

Frequency (MHz)	Reading (dBuV)	Antenna Factor (dB/m)	PreAmp (dB)	Cable Loss (dB)	Averager Level (dBuV/m)	Averager Limit (dBuV/m)	Margin (dB)
2390.82	47.02	27.07	42.46	7.33	38.96	54.00	15.04

**CH High 2462MHz Radiated Bandedge Antenna B for 802.11 b  
Horizontal, Peak Detector:**

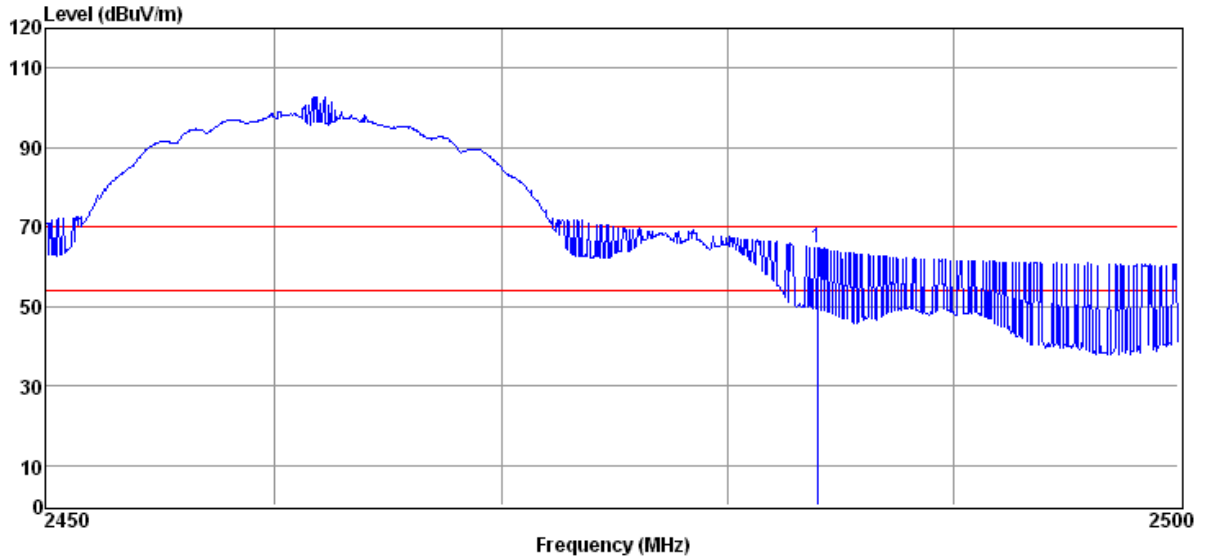

Frequency (MHz)	Reading (dBuV)	Antenna Factor (dB/m)	PreAmp (dB)	Cable Loss (dB)	Peak Level (dBuV/m)	Peak Limit (dBuV/m)	Margin (dB)
2483.38	72.47	27.35	42.49	7.31	64.64	74.00	9.36

**Horizontal, Averager Detector:**

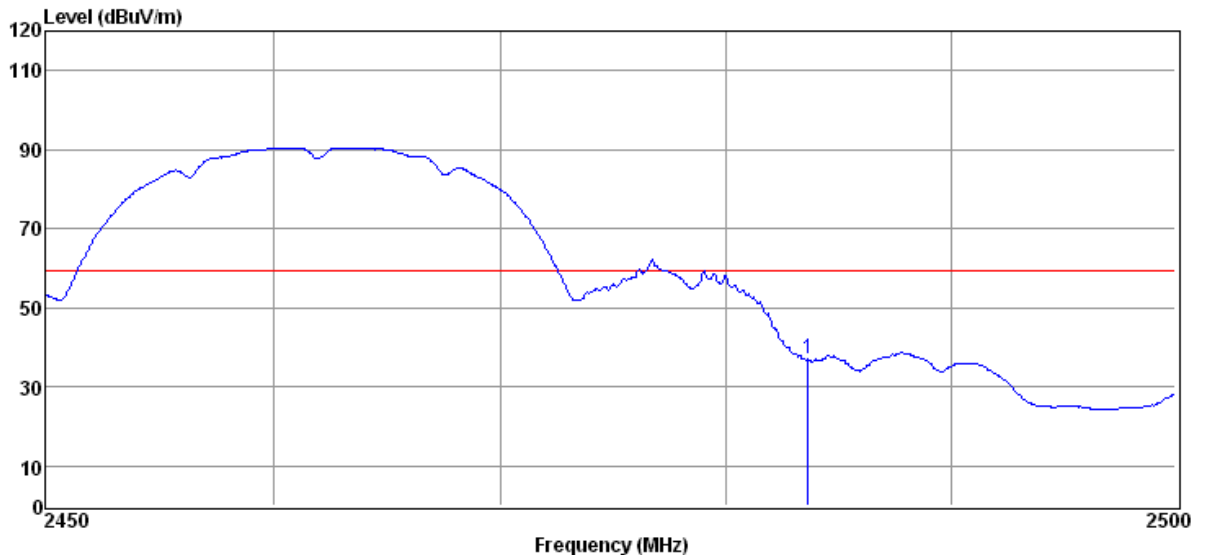

Frequency (MHz)	Reading (dBuV)	Antenna Factor (dB/m)	PreAmp (dB)	Cable Loss (dB)	Averager Level (dBuV/m)	Averager Limit (dBuV/m)	Margin (dB)
2483.46	44.90	27.35	42.49	7.31	37.07	54.00	16.93



**CH High 2462MHz Radiated Bandedge Antenna B for 802.11 b  
Vertical, Peak Detector:**

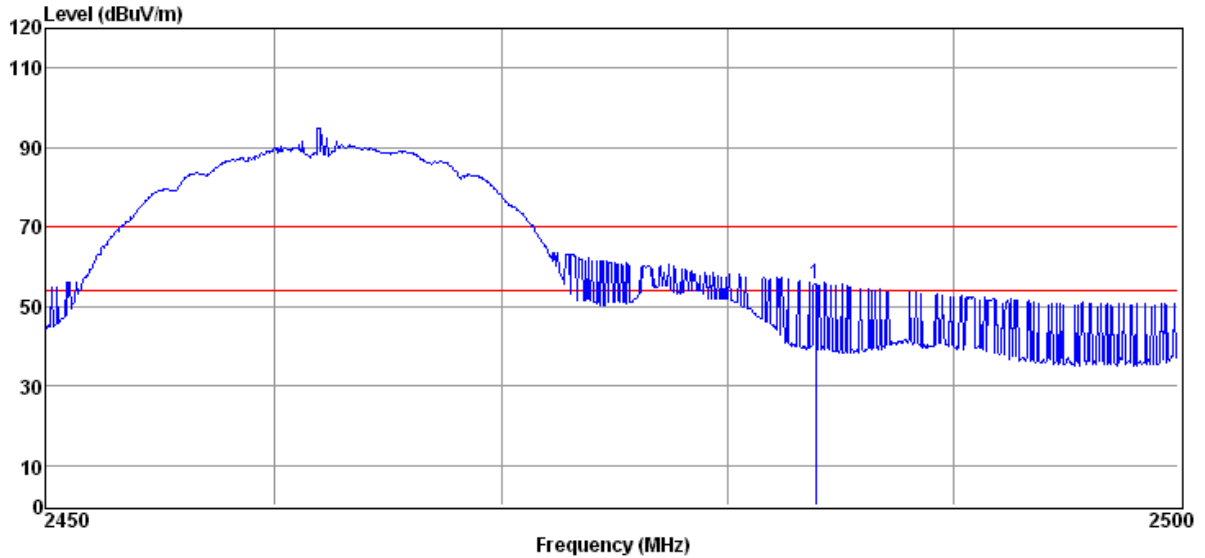

Frequency (MHz)	Reading (dBuV)	Antenna Factor (dB/m)	PreAmp (dB)	Cable Loss (dB)	Peak Level (dBuV/m)	Peak Limit (dBuV/m)	Margin (dB)
2483.47	64.66	27.35	42.49	7.31	56.83	74.00	17.17

**Vertical, Averager Detector:**

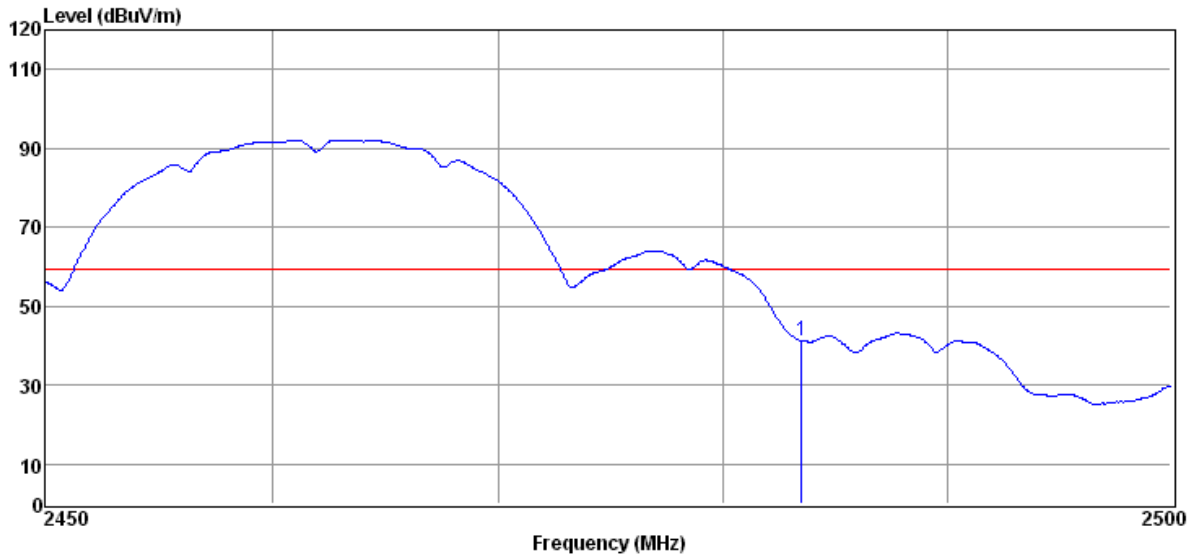

Frequency (MHz)	Reading (dBuV)	Antenna Factor (dB/m)	PreAmp (dB)	Cable Loss (dB)	Averager Level (dBuV/m)	Averager Limit (dBuV/m)	Margin (dB)
2483.49	49.04	27.35	42.49	7.31	41.21	54.00	12.79

**CH Low 2412MHz Radiated Bandedge Antenna B for 802.11 g  
Horizontal, Peak Detector:**

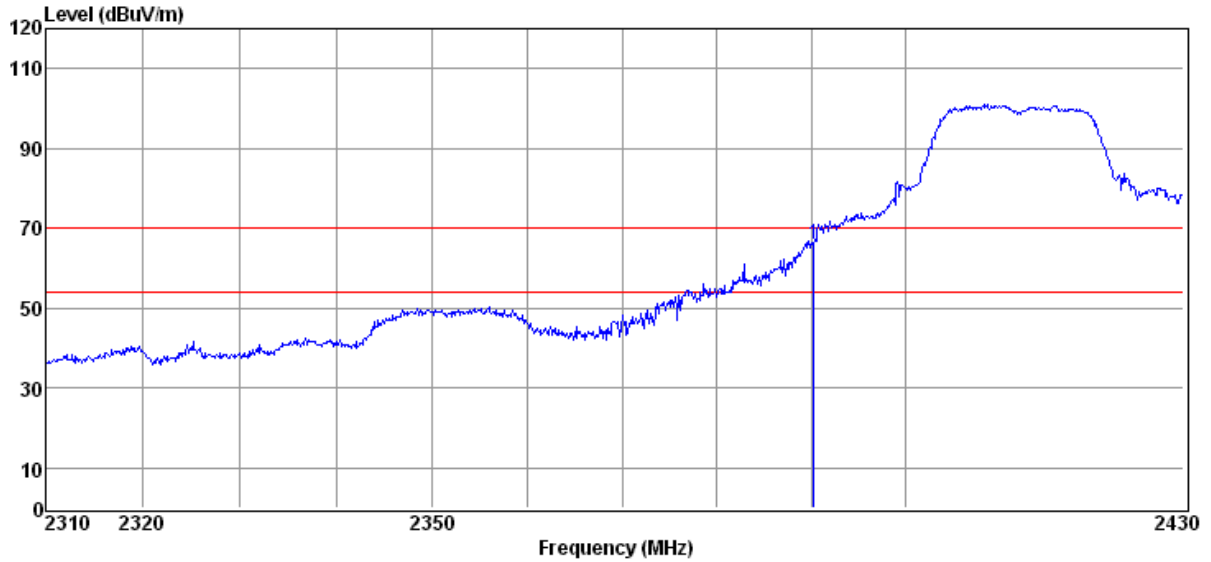

Frequency (MHz)	Reading (dBuV)	Antenna Factor (dB/m)	PreAmp (dB)	Cable Loss (dB)	Peak Level (dBuV/m)	Peak Limit (dBuV/m)	Margin (dB)
2390.33	74.09	27.07	42.46	7.33	66.03	74.00	7.97

**Horizontal, Averager Detector:**

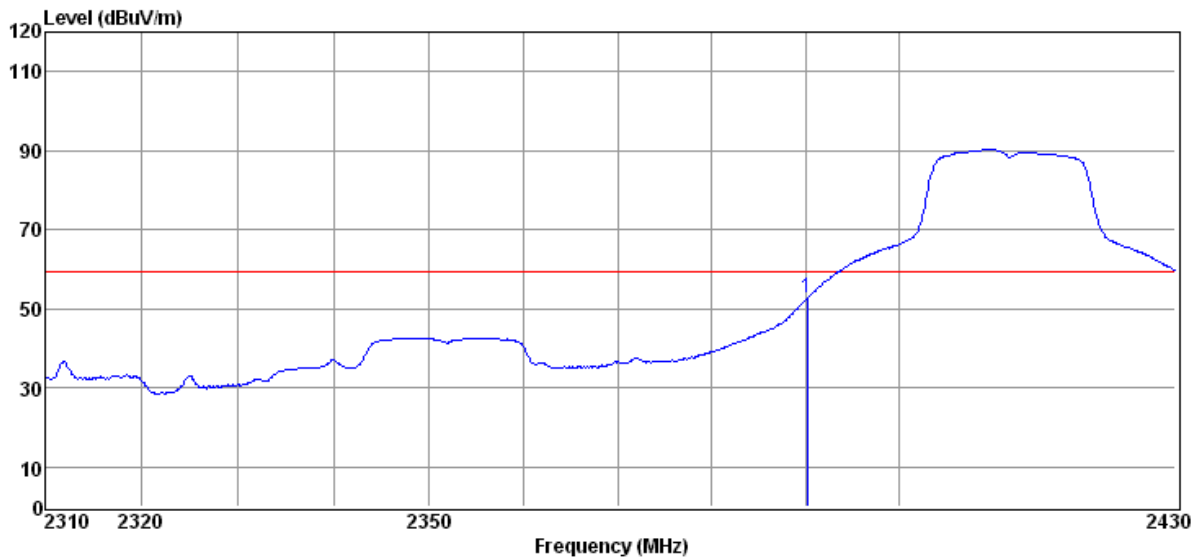

Frequency (MHz)	Reading (dBuV)	Antenna Factor (dB/m)	PreAmp (dB)	Cable Loss (dB)	Averager Level (dBuV/m)	Averager Limit (dBuV/m)	Margin (dB)
2390.21	58.80	27.07	42.46	7.33	50.74	54.00	3.26



**CH Low 2412MHz Radiated Bandedge Antenna B for 802.11 g**  
**Vertical, Peak Detector:**

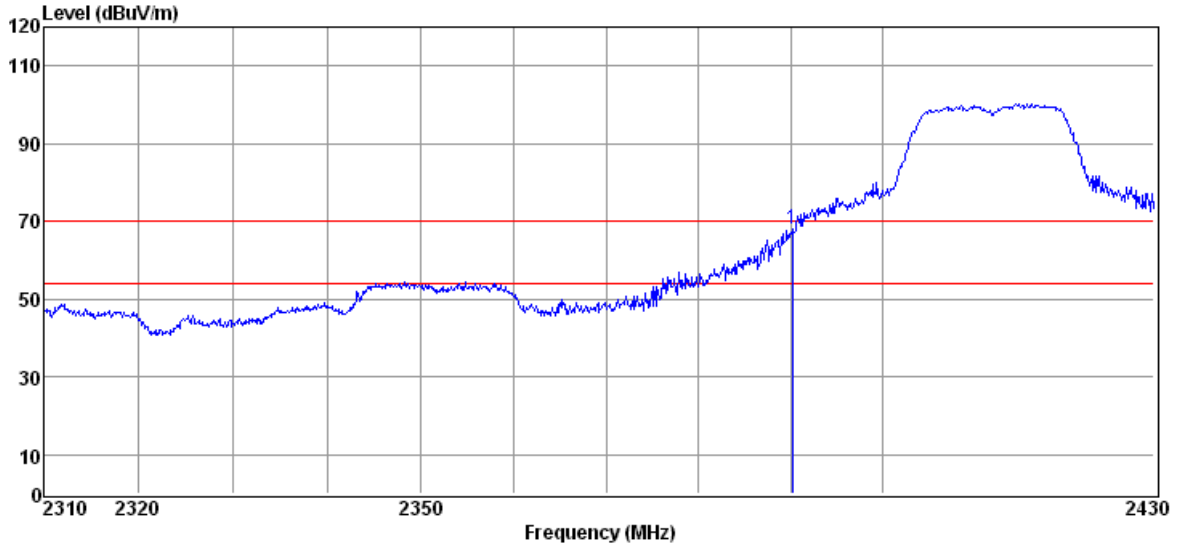

Frequency (MHz)	Reading (dBuV)	Antenna Factor (dB/m)	PreAmp (dB)	Cable Loss (dB)	Peak Level (dBuV/m)	Peak Limit (dBuV/m)	Margin (dB)
2390.31	75.21	27.07	42.46	7.33	67.15	74.00	6.85

**Vertical, Averager Detector:**

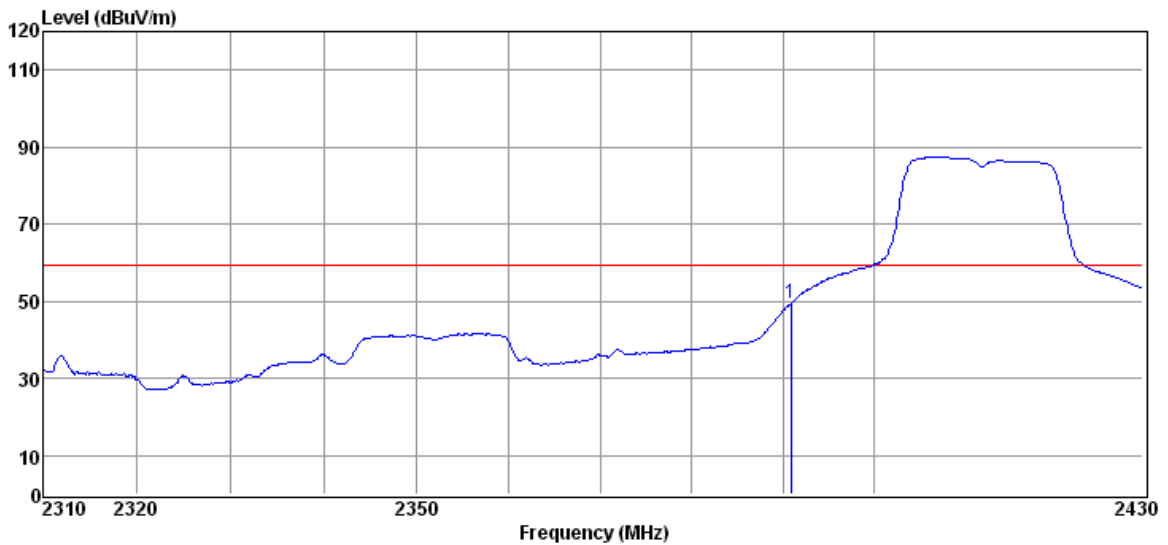

Frequency (MHz)	Reading (dBuV)	Antenna Factor (dB/m)	PreAmp (dB)	Cable Loss (dB)	Averager Level (dBuV/m)	Averager Limit (dBuV/m)	Margin (dB)
2390.94	57.65	27.07	42.46	7.33	49.59	54.00	4.41

**CH High 2462MHz Radiated Bandedge Antenna B for 802.11 g**

**Horizontal, Peak Detector:**

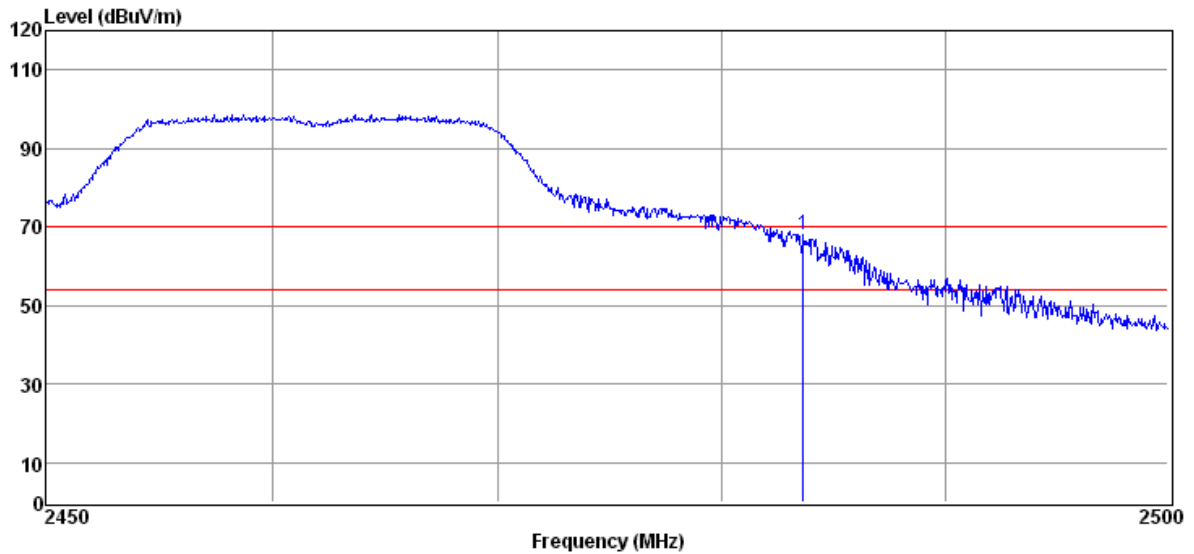

Frequency (MHz)	Reading (dBuV)	Antenna Factor (dB/m)	PreAmp (dB)	Cable Loss (dB)	Peak Level (dBuV/m)	Peak Limit (dBuV/m)	Margin (dB)
2483.42	75.93	27.35	42.49	7.31	68.10	74.00	5.90

**Horizontal, Averager Detector:**

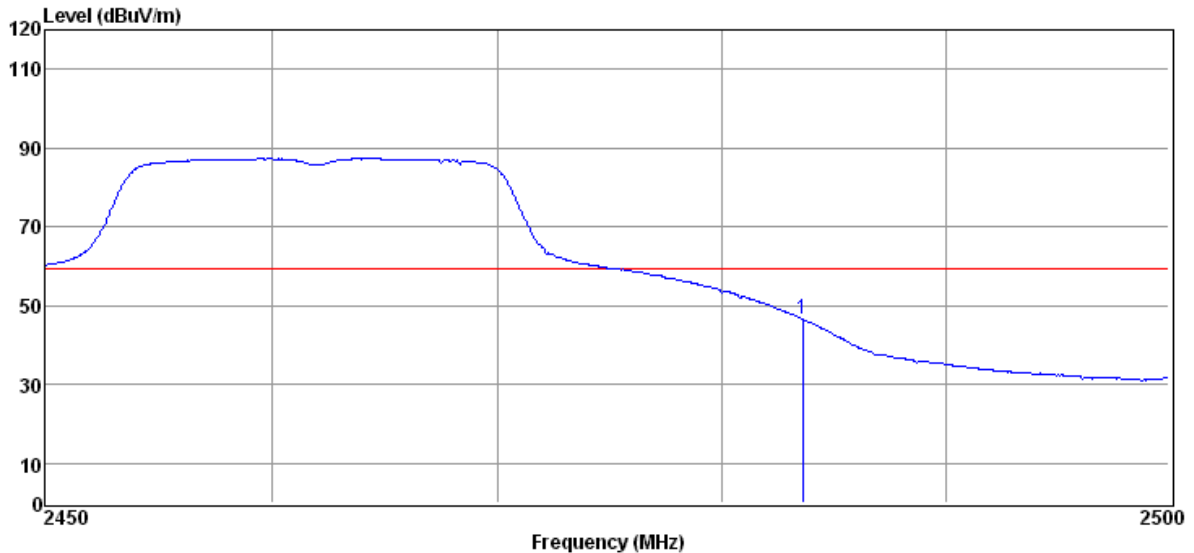

Frequency (MHz)	Reading (dBuV)	Antenna Factor (dB/m)	PreAmp (dB)	Cable Loss (dB)	Averager Level (dBuV/m)	Averager Limit (dBuV/m)	Margin (dB)
2483.44	54.46	27.35	42.49	7.31	46.63	54.00	7.37



**CH High 2462MHz Radiated Bandedge Antenna B for 802.11 g  
Vertical, Peak Detector:**

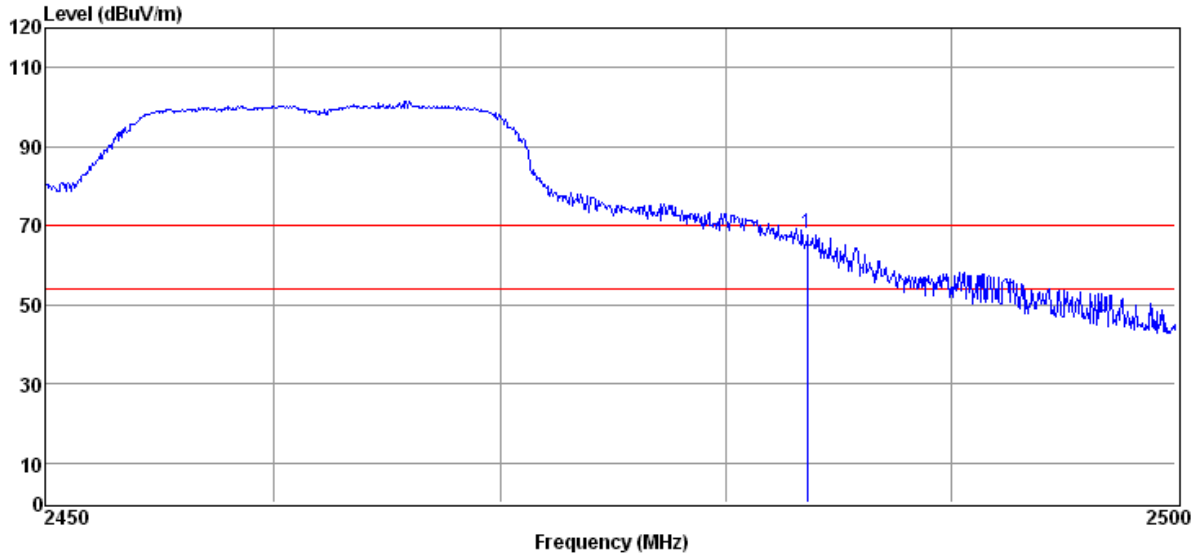

Frequency (MHz)	Reading (dBuV)	Antenna Factor (dB/m)	PreAmp (dB)	Cable Loss (dB)	Peak Level (dBuV/m)	Peak Limit (dBuV/m)	Margin (dB)
2483.37	76.07	27.35	42.49	7.31	68.24	74.00	5.76

**Vertical, Averager Detector:**

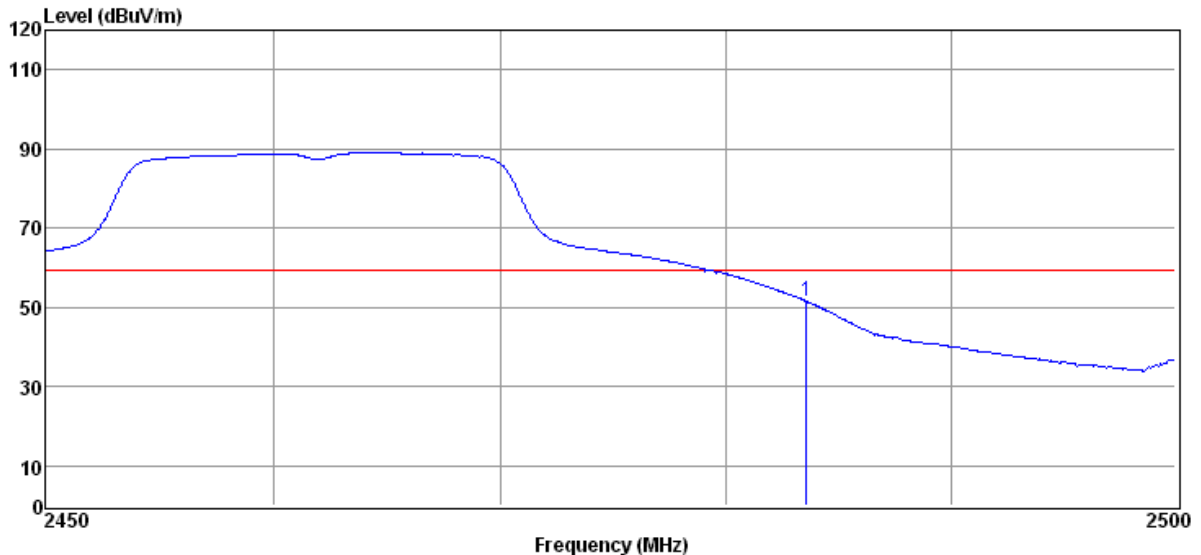

Frequency (MHz)	Reading (dBuV)	Antenna Factor (dB/m)	PreAmp (dB)	Cable Loss (dB)	Averager Level (dBuV/m)	Averager Limit (dBuV/m)	Margin (dB)
2483.47	57.86	27.35	42.49	7.31	50.03	54.00	3.97



Remark: 1. No any other emission which fall in restricted bands can be detected and be reported.

All frequencies within the "Restricted bands" have been evaluated to compliance. Section 15.205 Restricted bands of operation.

### 6.7 Conducted Spurious Emission Test

**Test Requirement:** FCC Part15 247(c)  
**Test date:** September 05, 2012  
**Standard Applicable:** According to section 15.247(c),in any 100KHz bandwidth outside the frequency bands in which the spread spectrum intentional radiator in operating,the radio frequency power that is produced by the intentional radiator shall be at least 20dB below that in the 100KHz bandwidth within the band that contains the highest level of the desired power,In addition,radiated emissions which fall in the restricted bands,as defined in section 15.205(a),must also comply with the radiated emission limits specified in 15.209(a).

**Measurement Procedure:**

1. Place the EUT on the table and set it in transmitting mode.
2. Remove the antenna from the EUT and then connect a low loss RF cable from the antenna port to the spectrum analyzer.
3. Set center frequency of spectrum analyzer = operating frequency.
4. Set the spectrum analyzer as RBW=100KHz VBW=300KHz, Sweep = auto
6. Repeat above procedures until all frequency measured were complete.

### Measurement Result: Conducted spurious Emission Measurement Result Antenna A for 802.11b CH Low 30MHz-25GHz

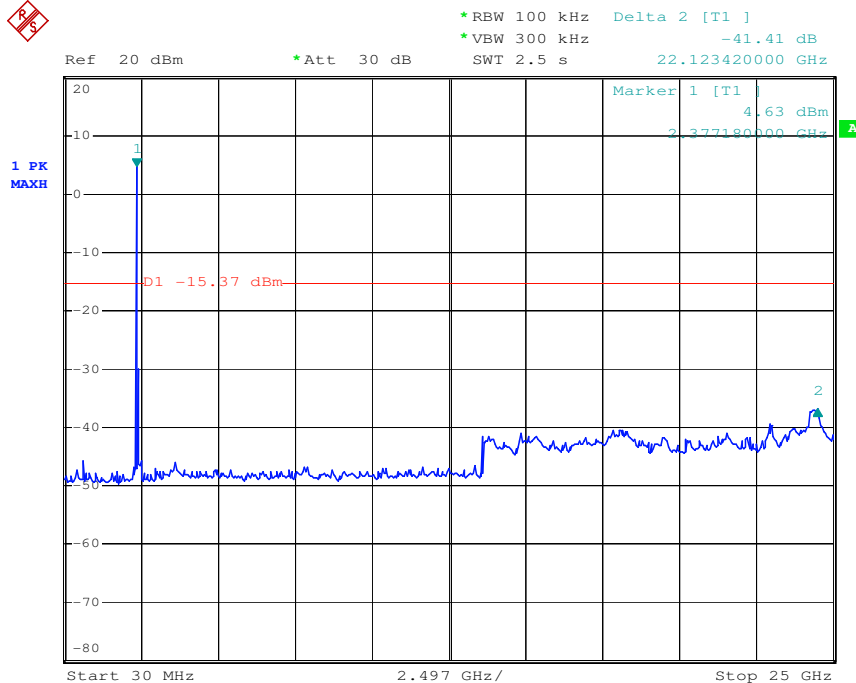

Date: 1.JAN.2000 05:42:40



Band Edge (Conducted Mode)

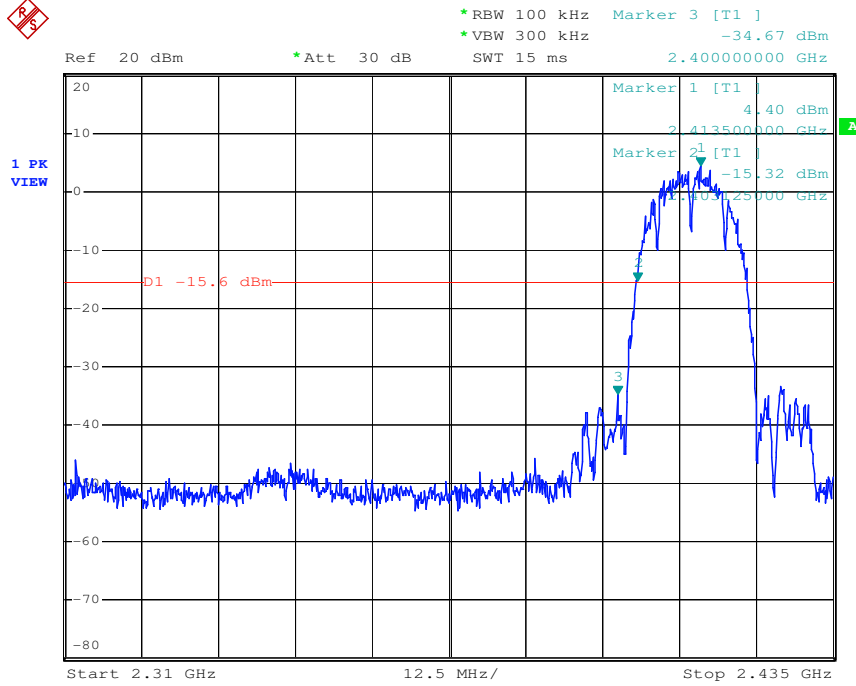

Date: 1.JAN.2000 05:38:04

Ch Mid 30MHz-25GHz

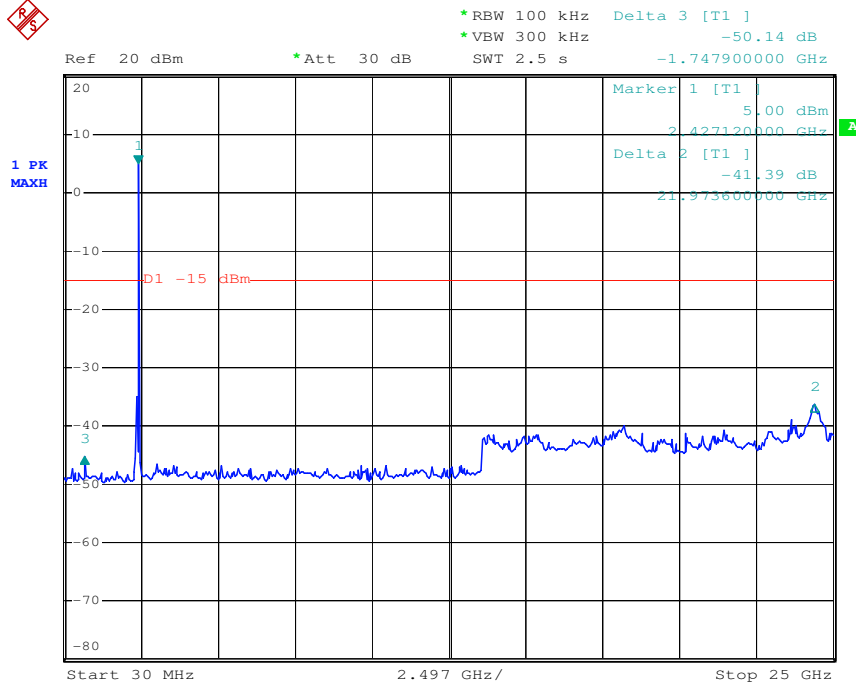

Date: 1.JAN.2000 06:05:38



Ch High 30MHz-25GHz

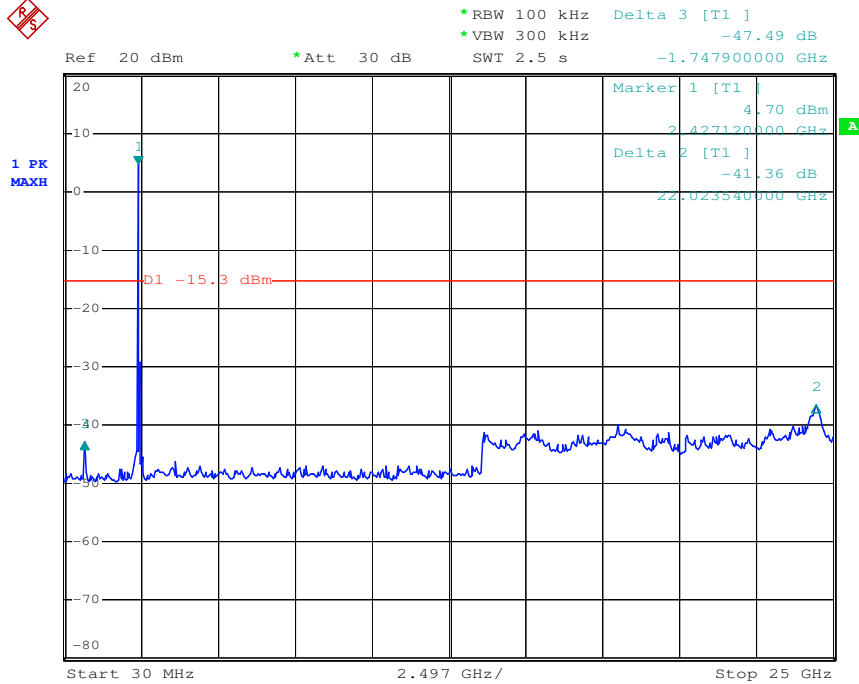

Date: 1.JAN.2000 06:20:01

Band Edge (Conducted Mode)

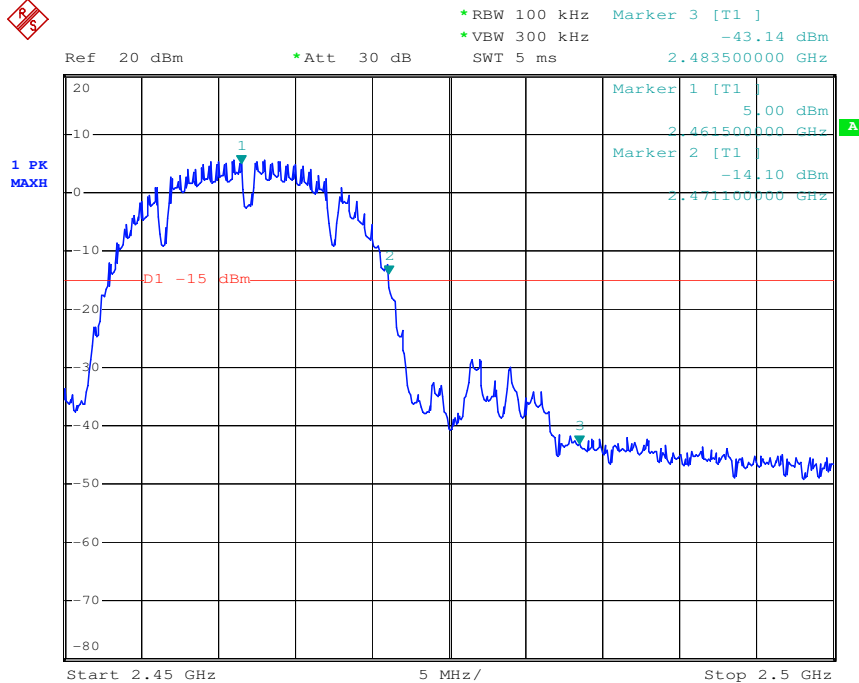

Date: 1.JAN.2000 02:58:48

Antenna A for 802.11g

This document is issued by the Company subject to its General Conditions of Service printed overleaf, available on request or accessible at [www.sgs.com/terms\\_and\\_conditions.htm](http://www.sgs.com/terms_and_conditions.htm) and, for electronic format documents, subject to Terms and Conditions for Electronic Documents at [www.sgs.com/terms\\_e-document.htm](http://www.sgs.com/terms_e-document.htm). Attention is drawn to the limitation of liability, indemnification and jurisdiction issues defined therein. Any holder of this document is advised that information contained hereon reflects the Company's findings at the time of its intervention only and within the limits of Client's instructions, if any. The Company's sole responsibility is to its Client and this document does not exonerate parties to a transaction from exercising all their rights and obligations under the transaction documents. This document cannot be reproduced except in full, without prior written approval of the Company. Any unauthorized alteration, forgery or falsification of the content or appearance of this document is unlawful and offenders may be prosecuted to the fullest extent of the law. Unless otherwise stated the results shown in this test report refer only to the sample(s) tested and such sample(s) are retained for 90 days only



CH Low 30MHz-25GHz

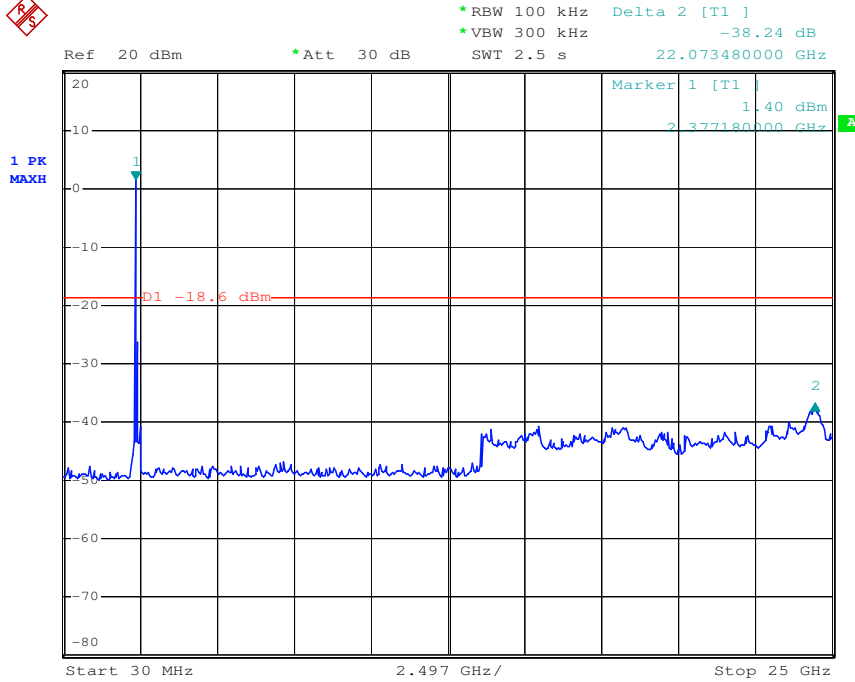

Date: 1.JAN.2000 06:46:26

Band Edge (Conducted Mode)

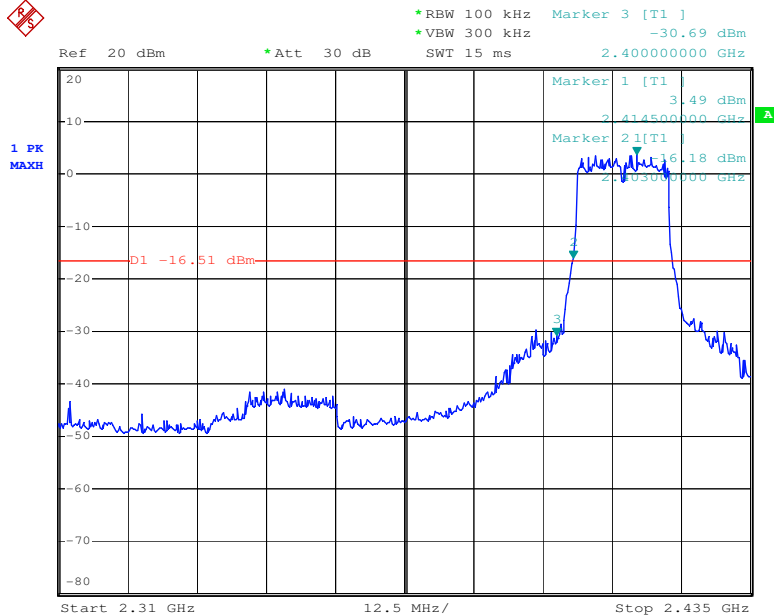

Date: 1.JAN.2000 06:48:17

Ch Mid 30MHz-25GHz



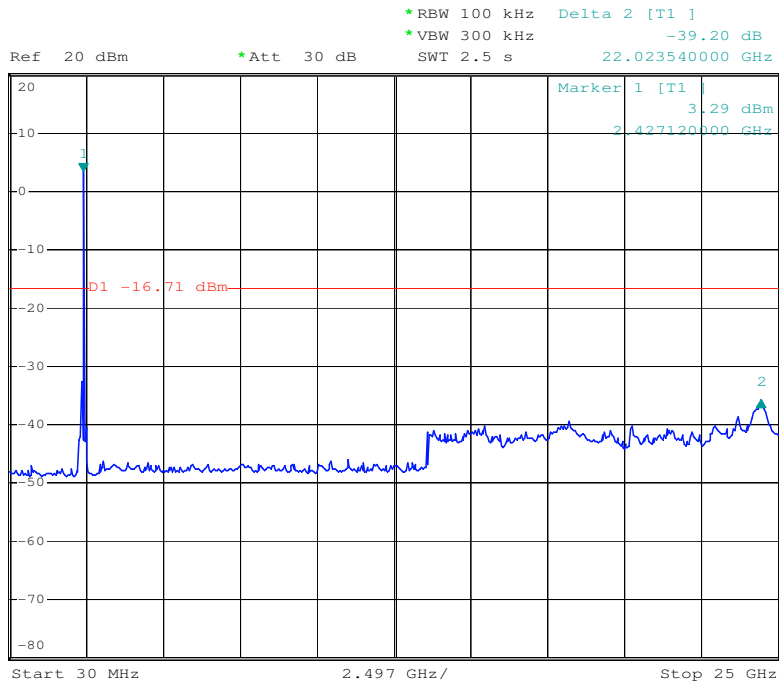

Date: 1.JAN.2000 07:11:40

Ch High 30MHz-25GHz

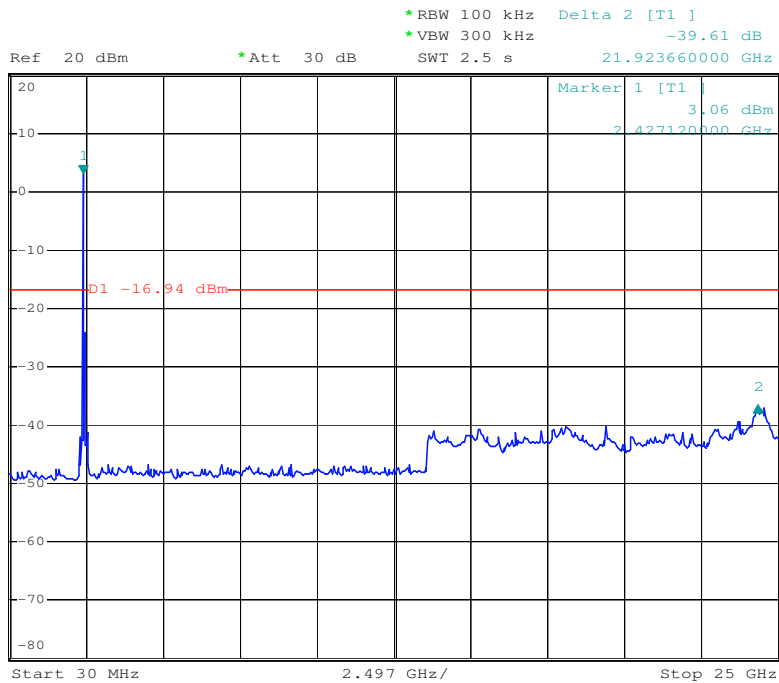

Date: 1.JAN.2000 07:28:39



Band Edge (Conducted Mode)

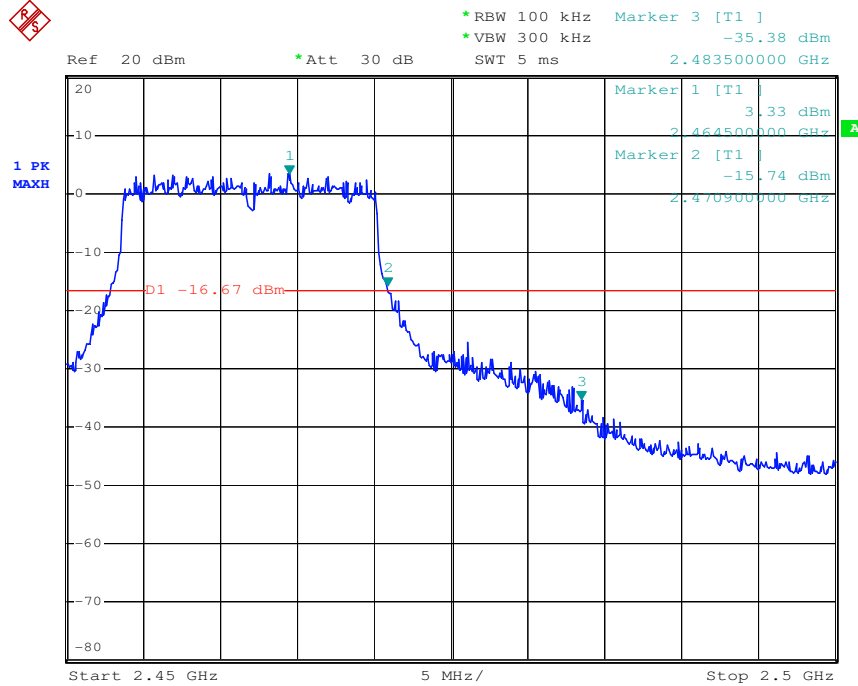

Date: 1.JAN.2000 07:30:22

**Antenna B for 802.11b**  
CH Low 30MHz-25GHz

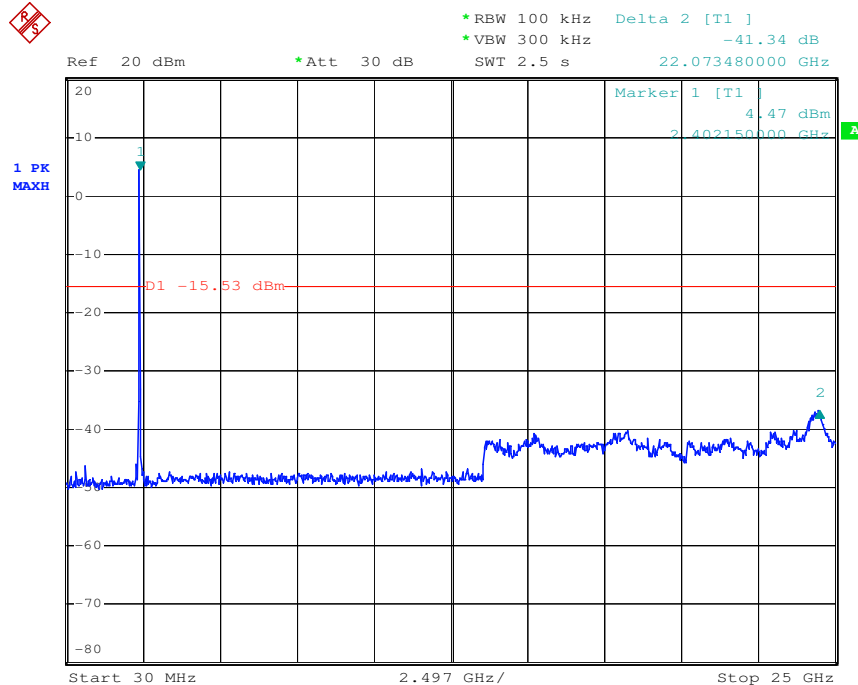

Date: 1.JAN.2000 00:29:39



Band Edge (Conducted Mode)

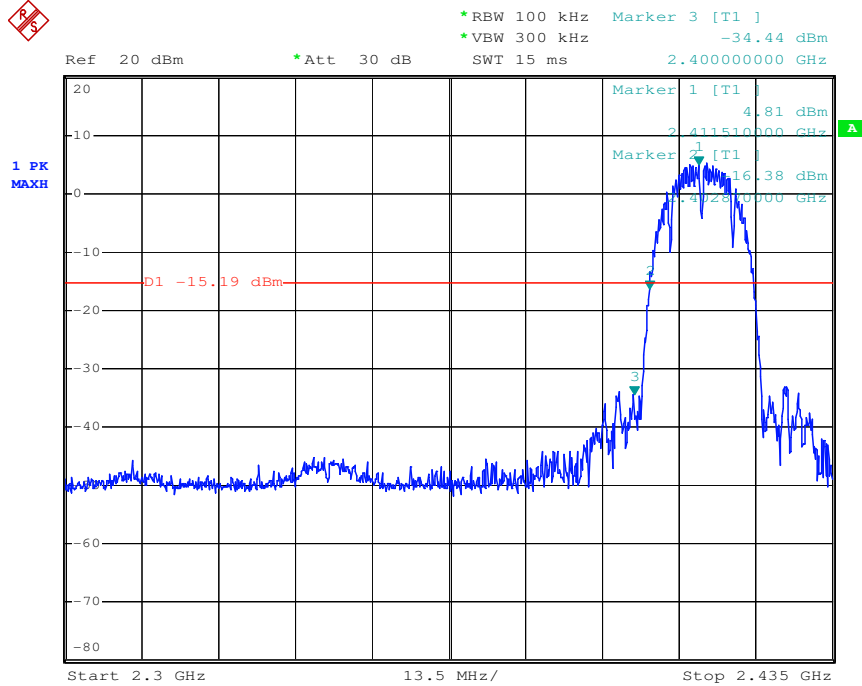

Date: 1.JAN.2000 00:32:01

Ch Mid 30MHz-25GHz

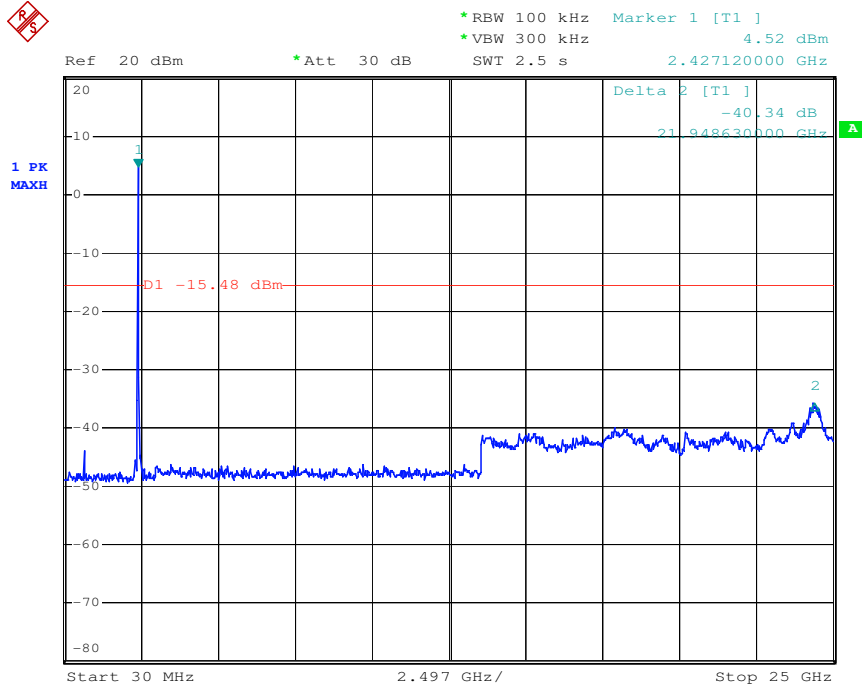

Date: 1.JAN.2000 01:00:02



Ch High 30MHz-25GHz

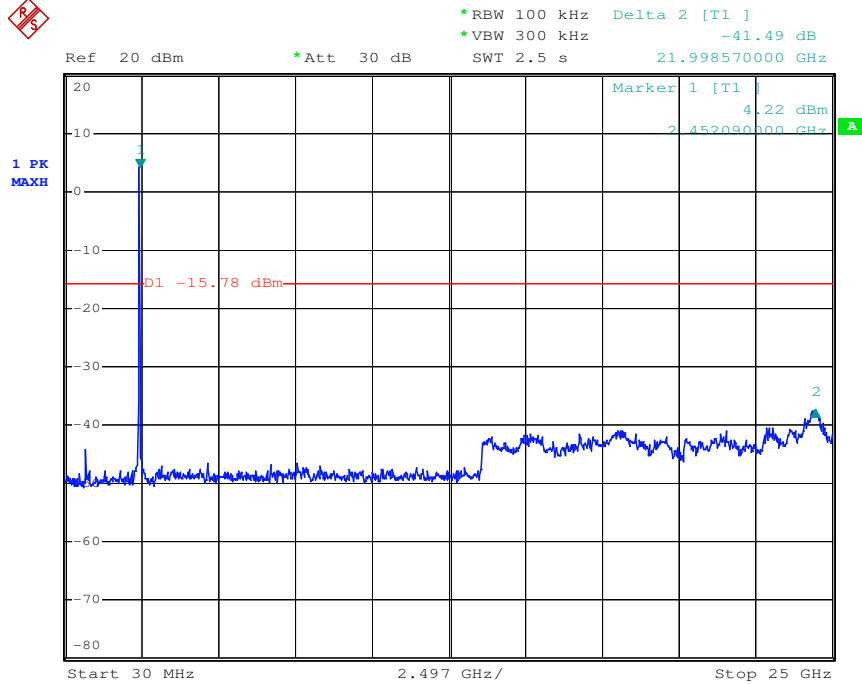

Date: 1.JAN.2000 01:14:02

Band Edge (Conducted Mode)

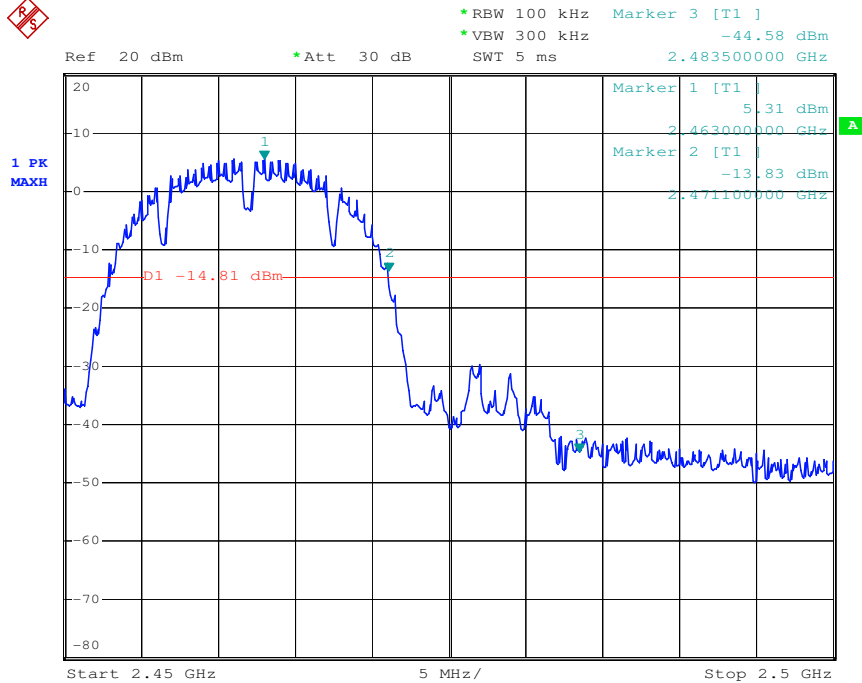

Date: 1.JAN.2000 03:05:13



**Antenna B for 802.11g**  
CH Low 30MHz-25GHz

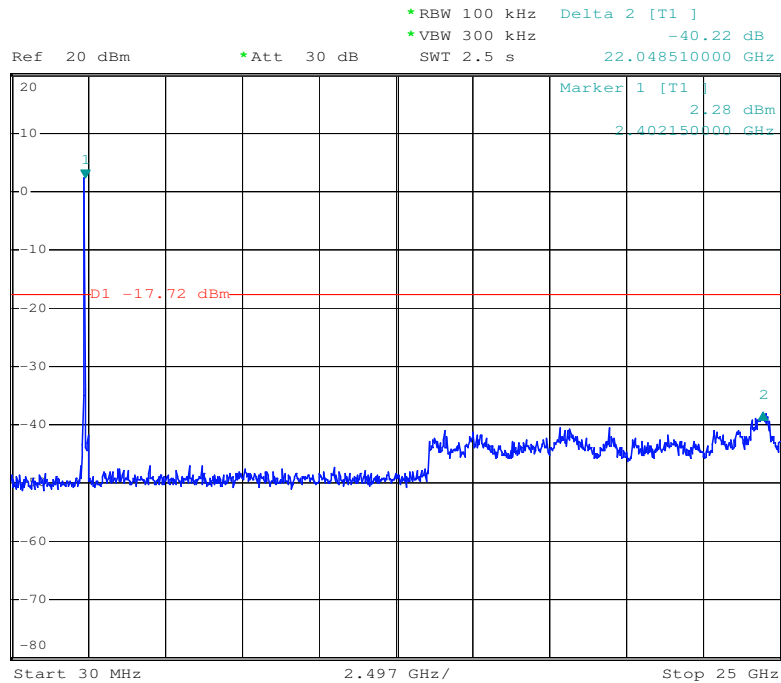

Date: 1.JAN.2000 01:28:13

**Band Edge (Conducted Mode)**

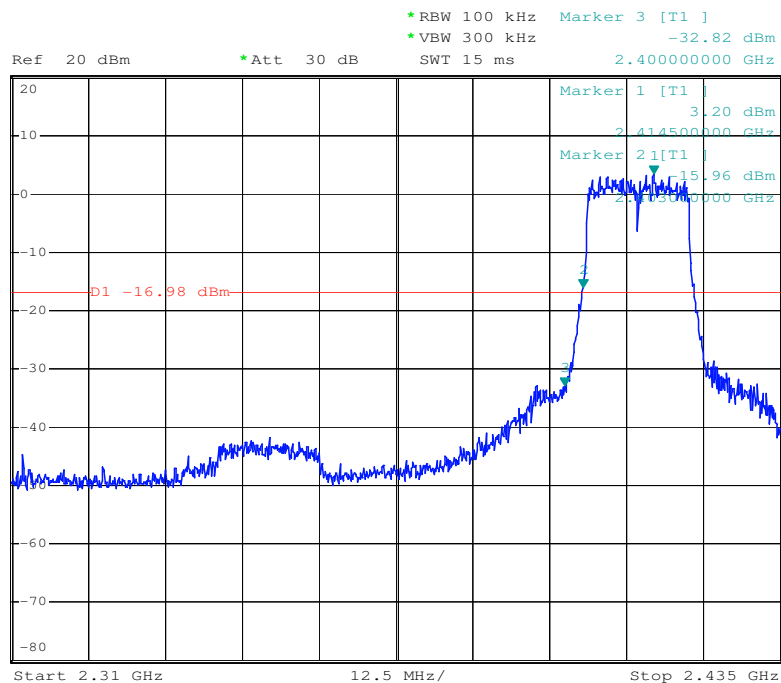

Date: 1.JAN.2000 01:27:18



Ch Mid 30MHz-25GHz

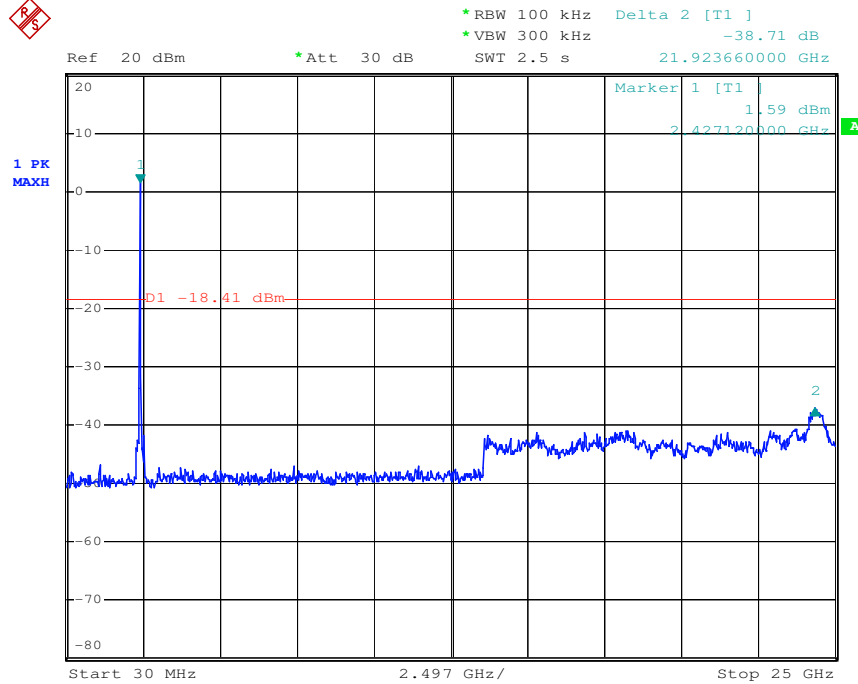

Date: 1.JAN.2000 02:10:50

Ch High 30MHz-25GHz

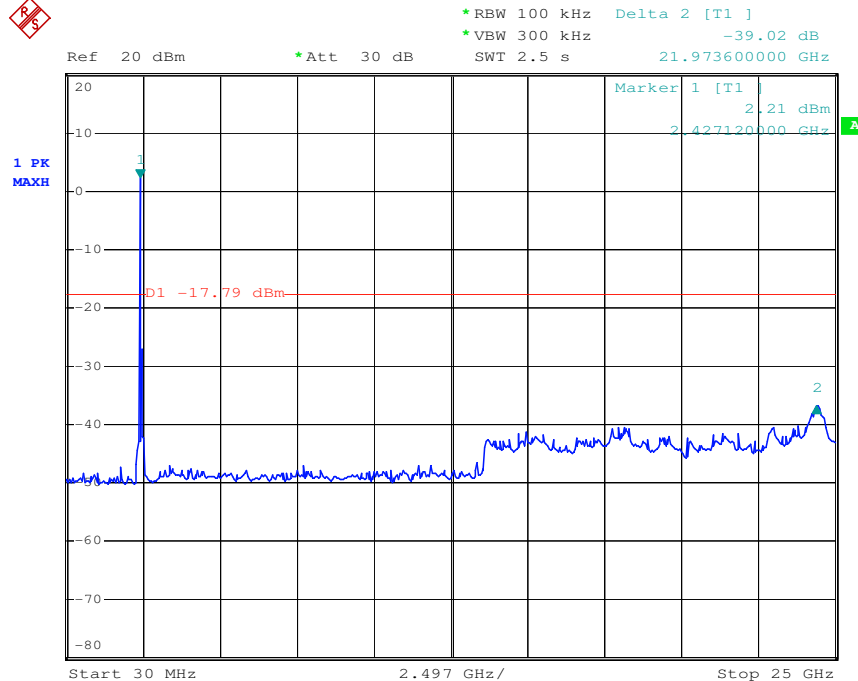

Date: 1.JAN.2000 02:24:21



Band Edge (Conducted Mode)

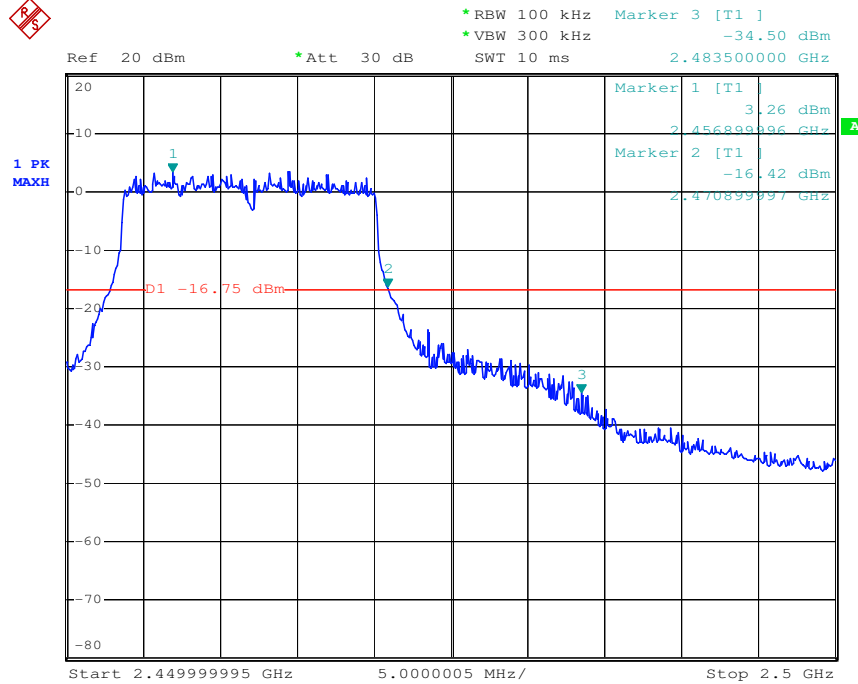

Date: 1.JAN.2000 02:26:17

## 6.8 Peak Power Spectral Density

**Test Requirement:** FCC Part15 247(e)

**Test date:** September. 06, 2012

**Standard Applicable:** According to section 15.247(e), For digitally modulated systems, the power spectral density conducted from the intentional radiator to the antenna shall not be greater than 8dB in any 3KHz band during any time in terval of continuous transmission. This power spectral density shall be determined in accordance with the provisions of paragraph(b) of this section. The same method of determining the conducted output power shall be used to determine the powr spectral density.

**Measurement Procedure:** The EUT was tested according to ANSI C63.10 to FCC 47CFR 15.247 requiremnts.

Set RBW=3KHz, Set VBW=10KHz, Span=3MHz, Sweep time=100s, Set detector=Peak detector.

### Measurement Result:

802.11b

For Antenna A

CH	Frequency (MHz)	Reading (dBm)	Cable Loss (dB)	RF Power Density (dBm)	Limit (dBm)	Result
LOW	2412	-7.68	0.6	-7.08	8	PASS
MID	2437	-7.97	0.6	-7.37	8	PASS
HIGH	2462	-7.63	0.6	-7.03	8	PASS

802.11g

For Antenna A

CH	Frequency (MHz)	Reading (dBm)	Cable Loss (dB)	RF Power Density (dBm)	Limit (dBm)	Result
LOW	2412	-11.08	0.6	-10.48	8	PASS
MID	2437	-10.07	0.6	-9.47	8	PASS
HIGH	2462	-11.61	0.6	-11.01	8	PASS

802.11b

For Antenna B

CH	Frequency (MHz)	Reading (dBm)	Cable Loss (dB)	RF Power Density (dBm)	Limit (dBm)	Result
LOW	2412	-8.09	0.6	-7.49	8	PASS
MID	2437	-7.61	0.6	-7.01	8	PASS
HIGH	2462	-8.12	0.6	-7.52	8	PASS

802.11g

For Antenna B

CH	Frequency (MHz)	Reading (dBm)	Cable Loss (dB)	RF Power Density (dBm)	Limit (dBm)	Result
LOW	2412	-12.02	0.6	-11.42	8	PASS
MID	2437	-11.11	0.6	-10.51	8	PASS
HIGH	2462	-10.47	0.6	-9.87	8	PASS





Power Spectral Density Test Plot  
802.11b Low Channel



Antenna A

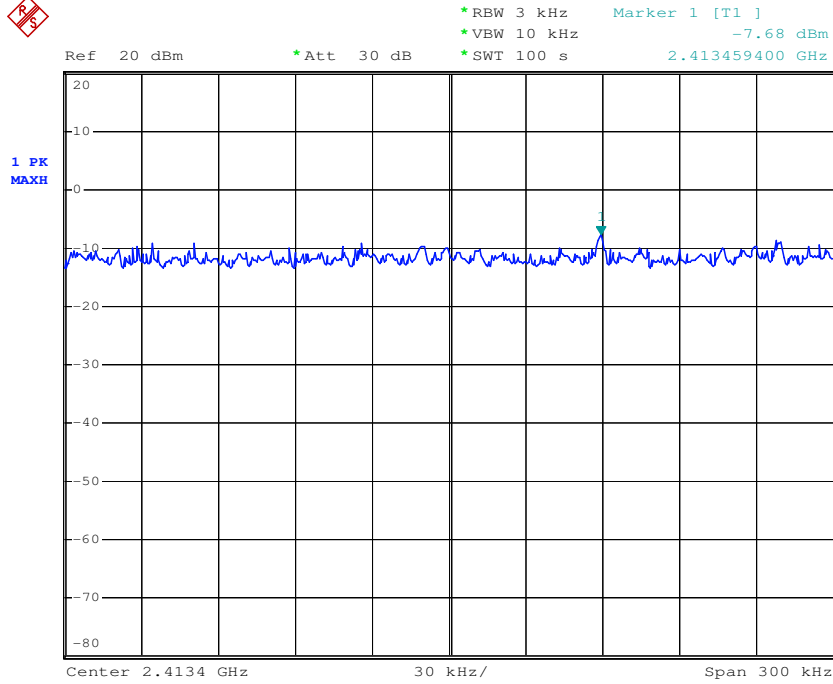

Date: 1.JAN.2000 05:49:01

802.11b Middle Channel



Antenna A

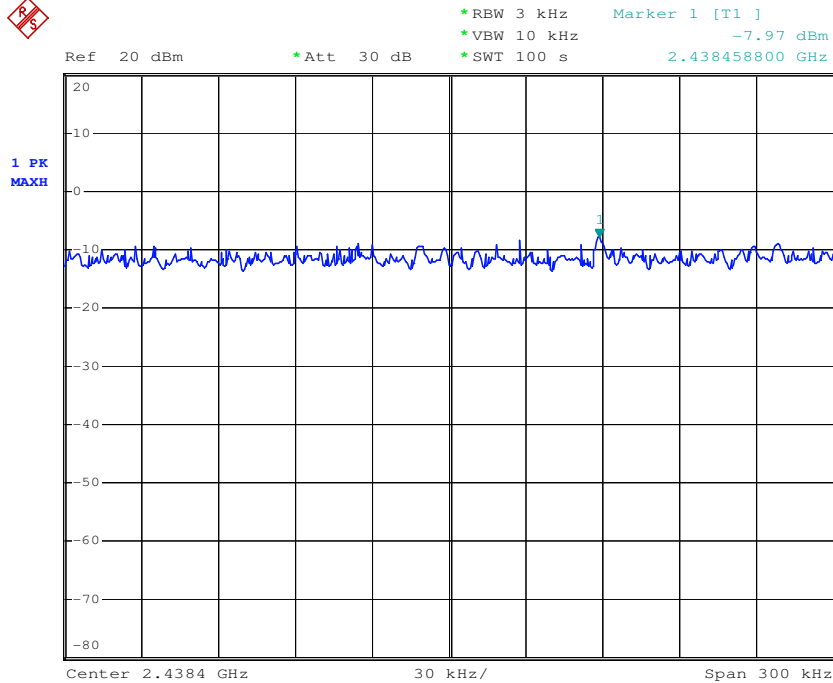

Date: 1.JAN.2000 06:15:11



802.11b High Channel

Antenna A

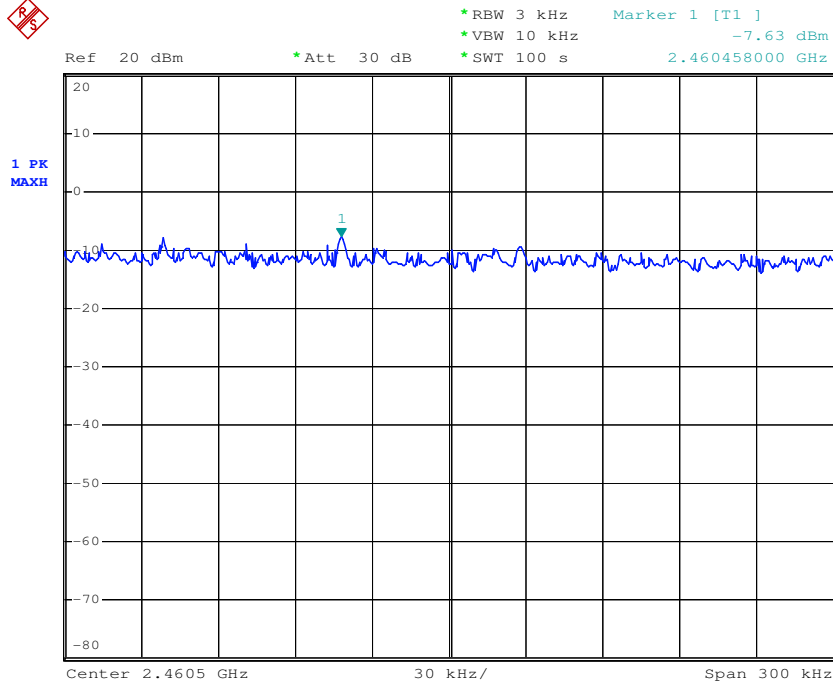

802.11g Low Channel

Antenna A

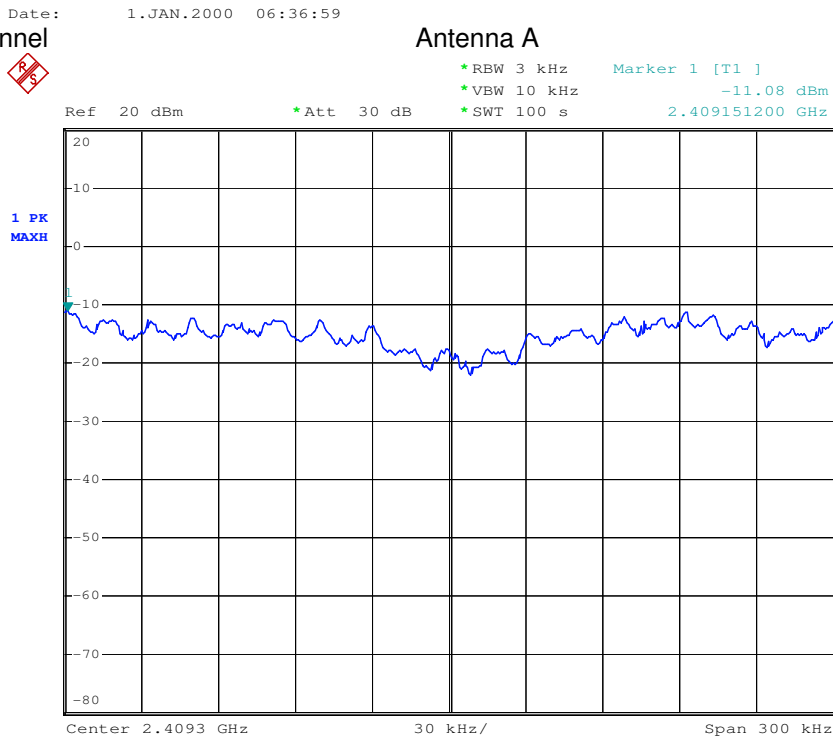

Date: 1.JAN.2000 06:58:55



802.11g Middle Channel

Antenna A

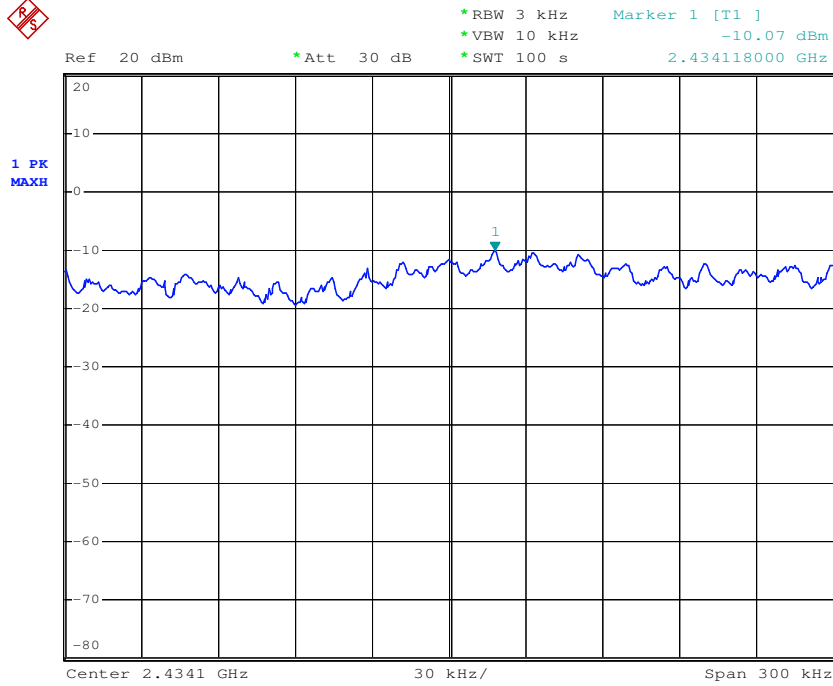

802.11g High Channel

Antenna A

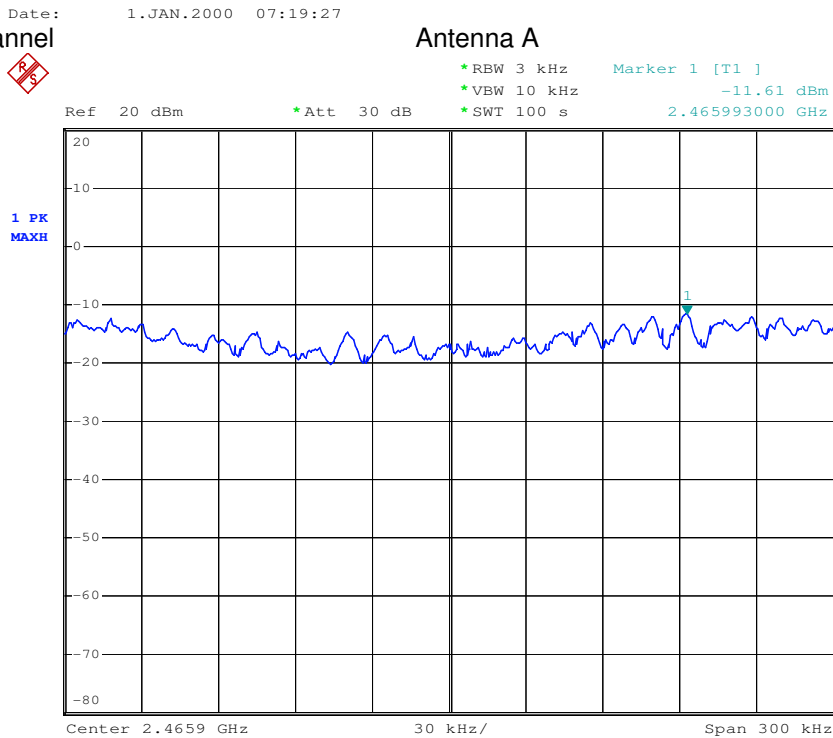

Date: 1.JAN.2000 07:47:52



802.11b Low Channel

Antenna B

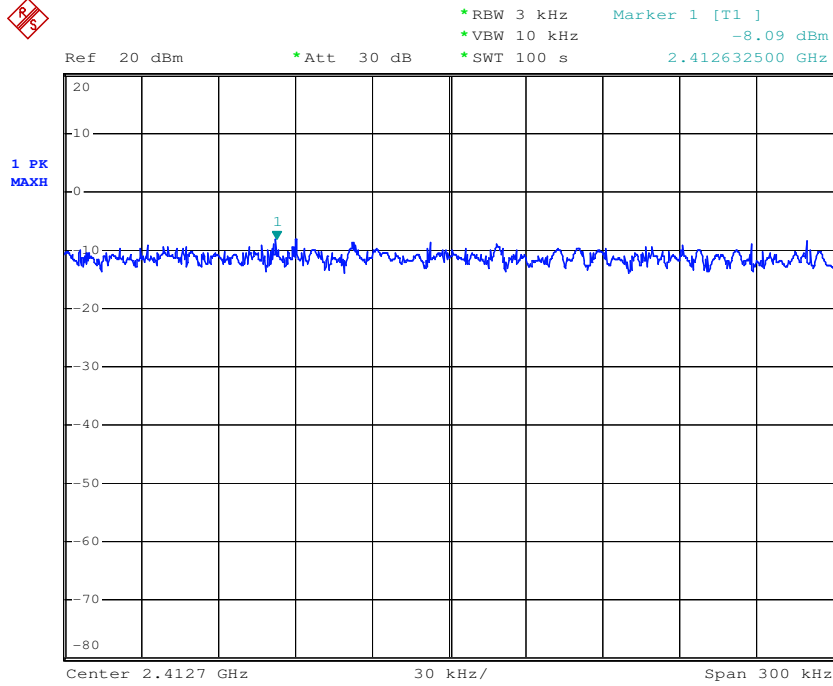

Date: 1.JAN.2000 00:39:35

802.11b Middle Channel

Antenna B

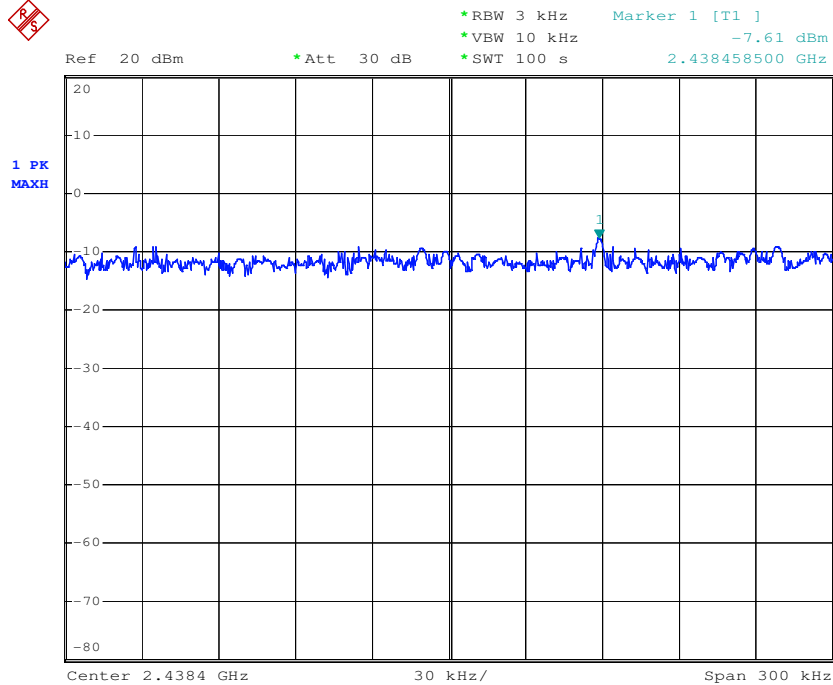

Date: 1.JAN.2000 01:06:21



802.11b High Channel



Antenna B

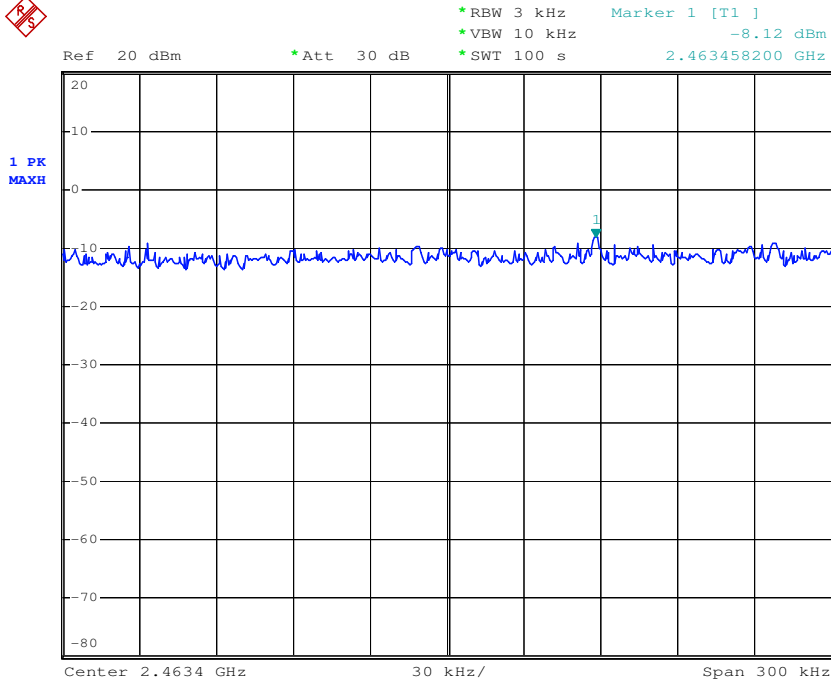

802.11g Low Channel



Antenna B

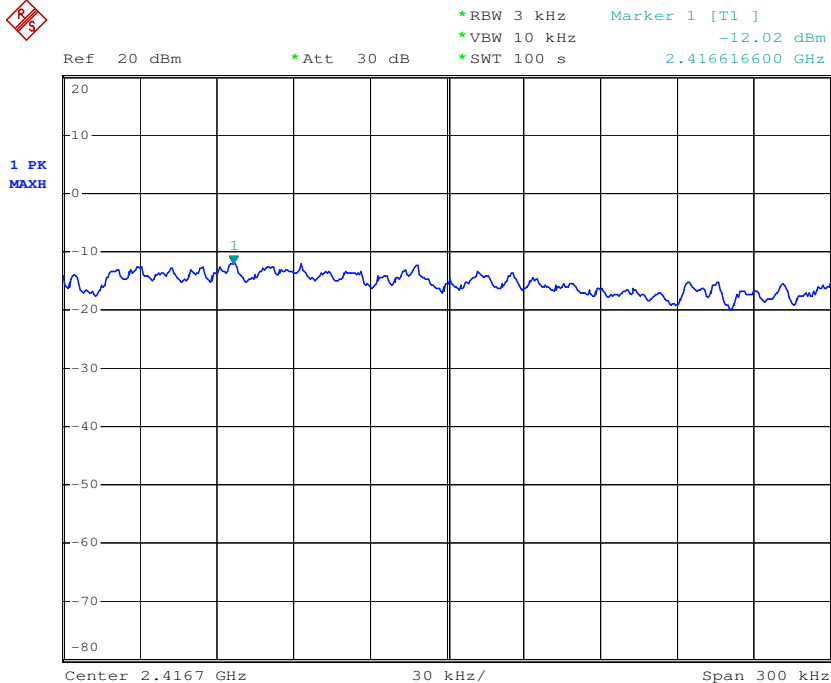

Date: 1.JAN.2000 02:43:48



802.11g Middle Channel

Antenna B

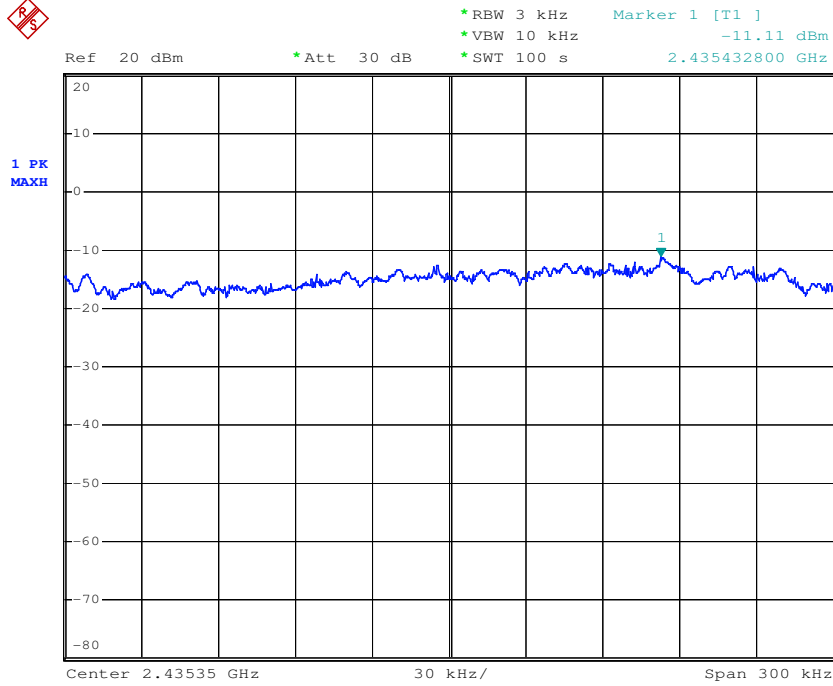

802.11g High Channel

Antenna B

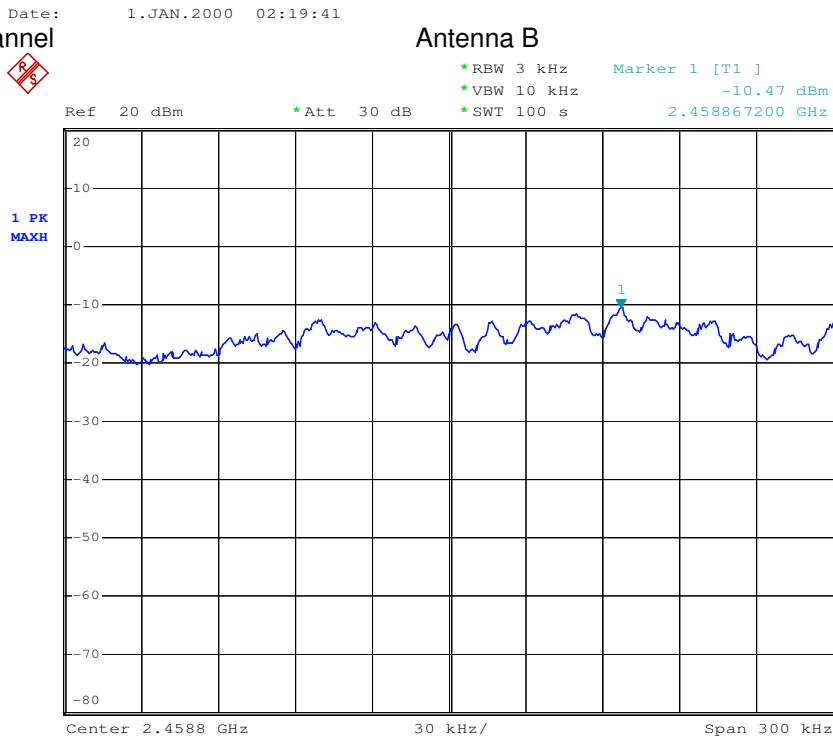

Date: 1.JAN.2000 02:30:47

## 6.9 Occupied Bandwidth Test

<b>Test Requirement:</b>	RSS-Gen Issue 3 Clause 4.6.1
<b>Test date:</b>	September. 11, 2012
<b>Standard Applicable</b>	According to the section RSS-Gen Issue 3 Clause 4.6.1
<b>EUT Setup</b>	The occupied bandwidth per RSS-Gen Issue 3 Clause 4.6.1 was measured using the Spectrum Analyzer with the resolutions set at 100kHz,the video bandwidth set at 300kHz.

### Measurement Result:

802.11b For Antenna A		
Channel	Frequency (MHz)	Bandwidth (MHz)
LOW	2412	16.08
MID	2437	16.16
HIGH	2462	16.08

802.11g For Antenna A		
Channel	Frequency (MHz)	Bandwidth (MHz)
LOW	2412	16.56
MID	2437	16.56
HIGH	2462	16.56

802.11b For Antenna B		
Channel	Frequency (MHz)	Bandwidth (MHz)
LOW	2412	16.08
MID	2437	16.08
HIGH	2462	16.08

802.11g For Antenna B		
Channel	Frequency (MHz)	Bandwidth (MHz)
LOW	2412	16.48
MID	2437	16.48
HIGH	2462	16.56



802.11b Low Channel

Antenna A

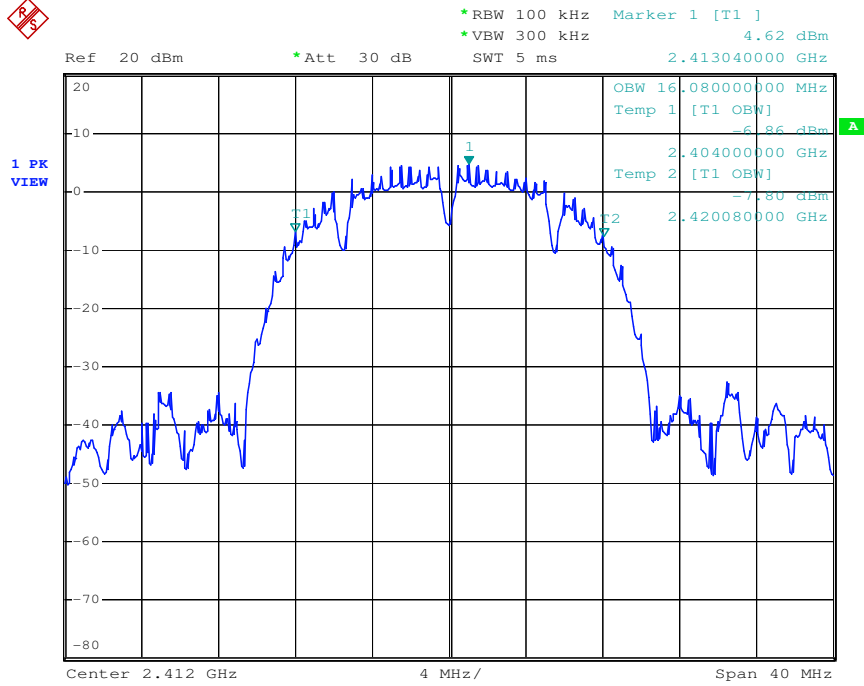

802.11b Middle Channel

Antenna A

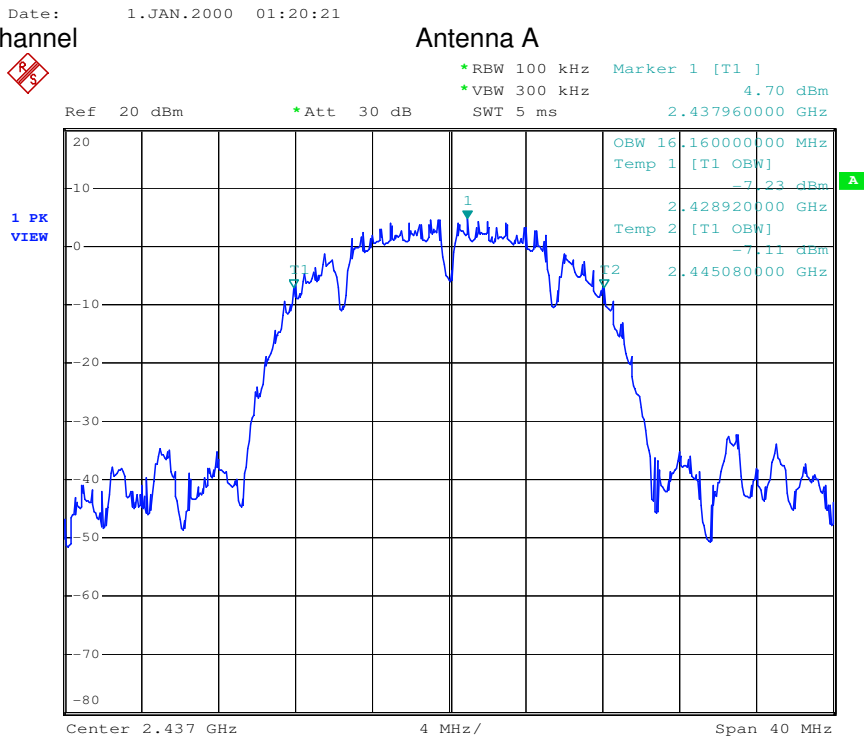

Date: 1.JAN.2000 01:21:09





802.11b High Channel



Antenna A

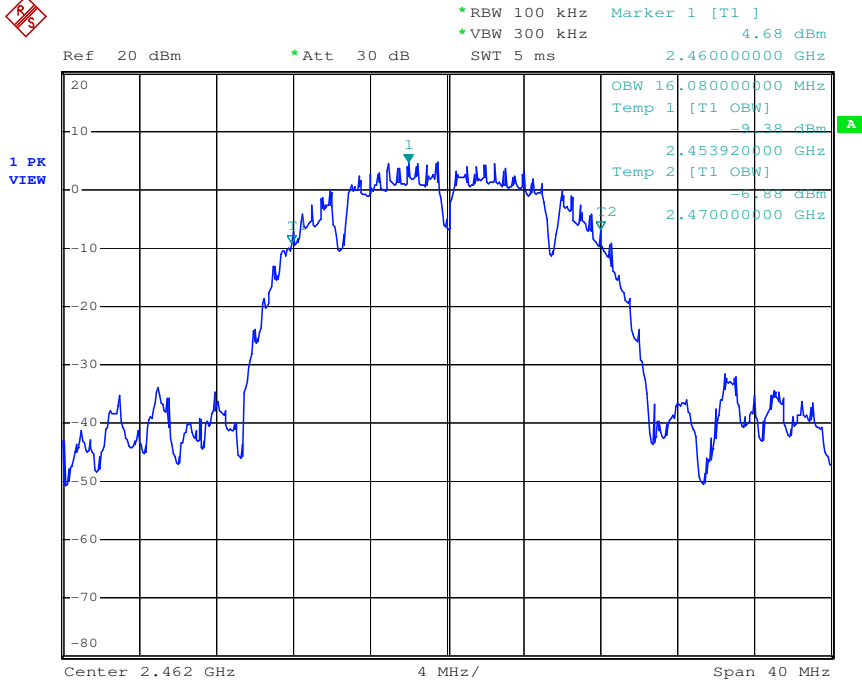

802.11g Low Channel



Antenna A

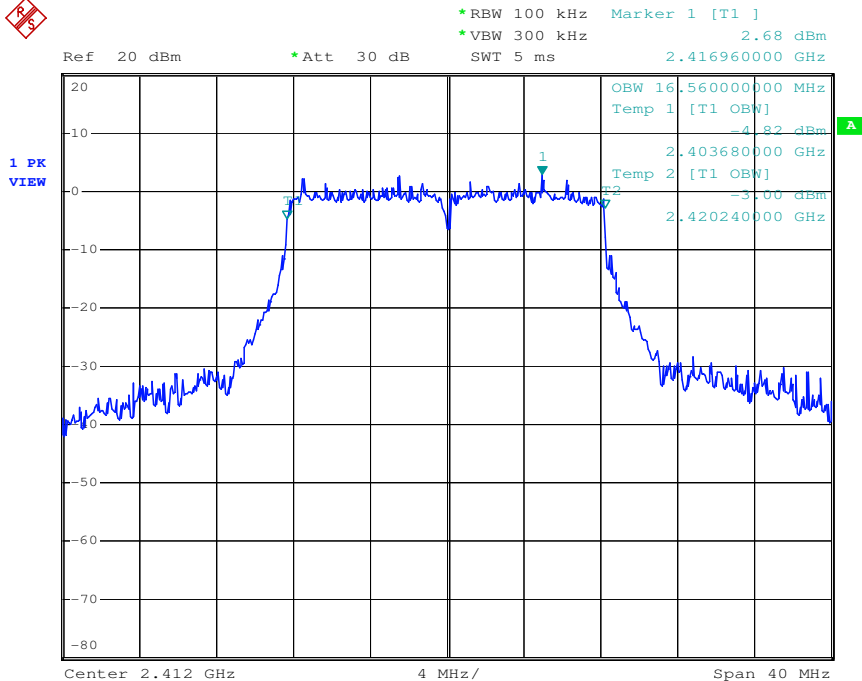

Date: 1.JAN.2000 01:22:41

Date: 1.JAN.2000 01:23:52



802.11g Middle Channel

Antenna A

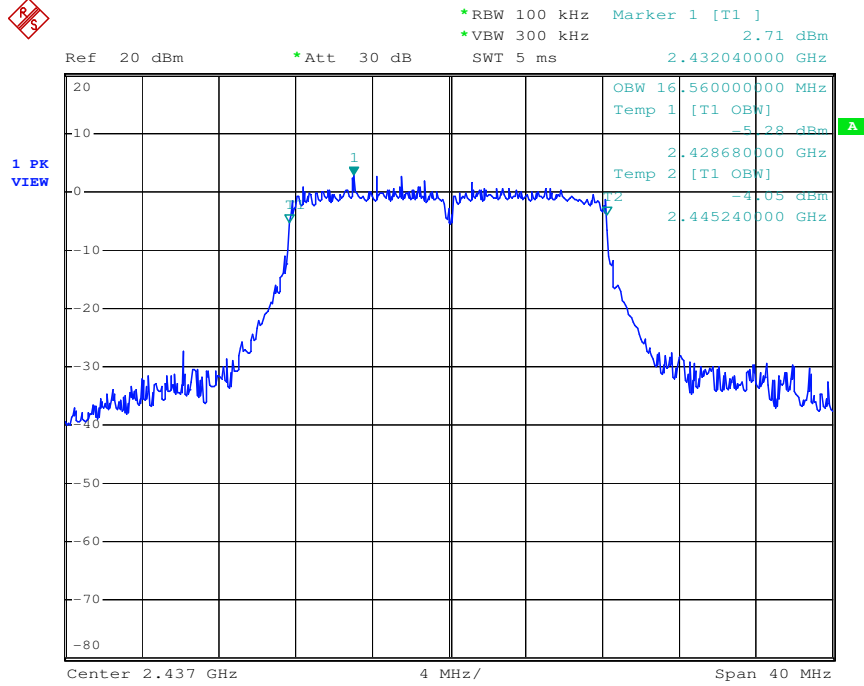

802.11g High Channel

Antenna A

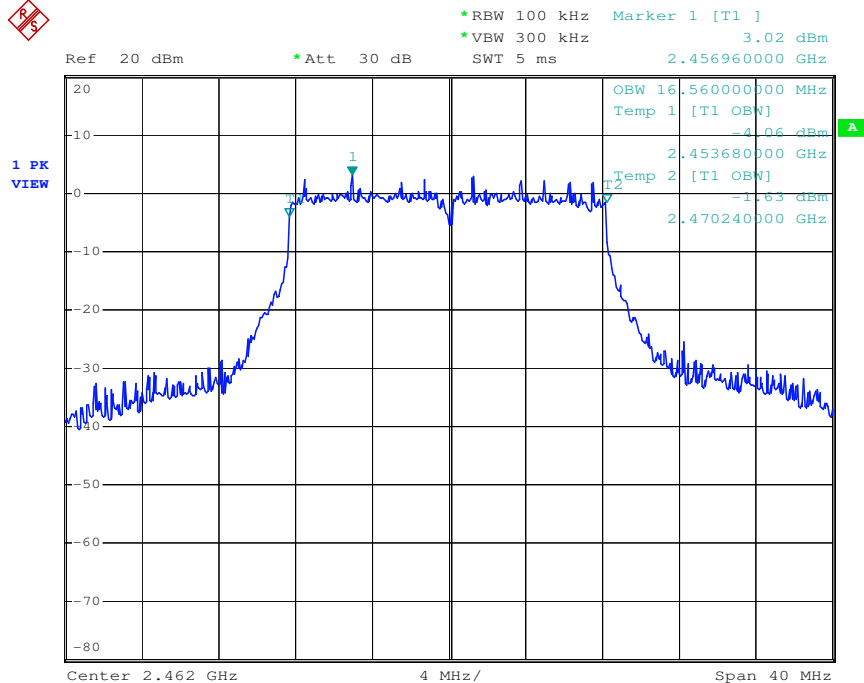

Date: 1.JAN.2000 01:27:39



802.11b Low Channel

Antenna B

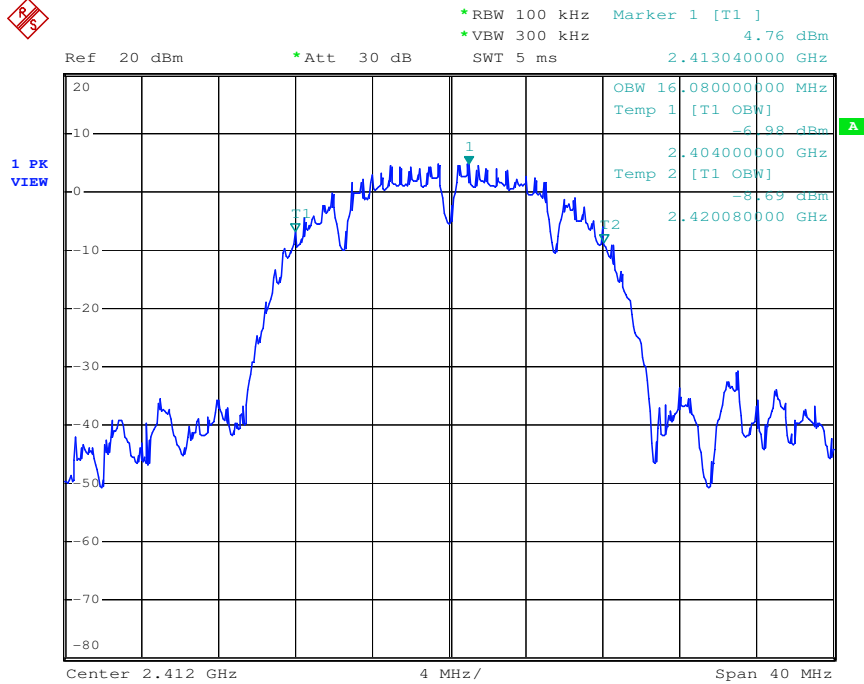

802.11b Middle Channel

Antenna B

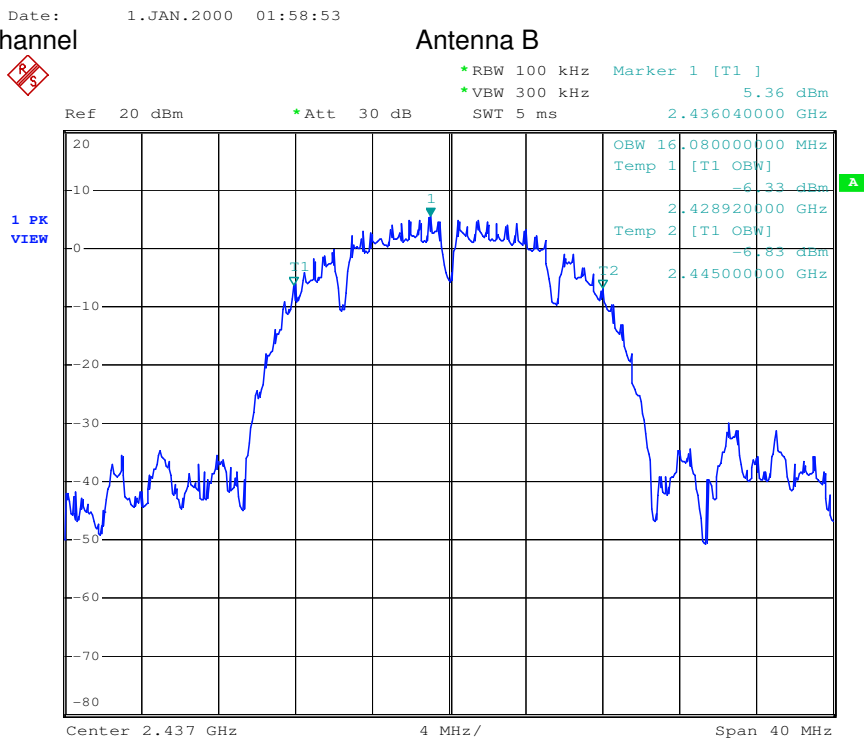

Date: 1.JAN.2000 02:01:05



802.11b High Channel

Antenna B

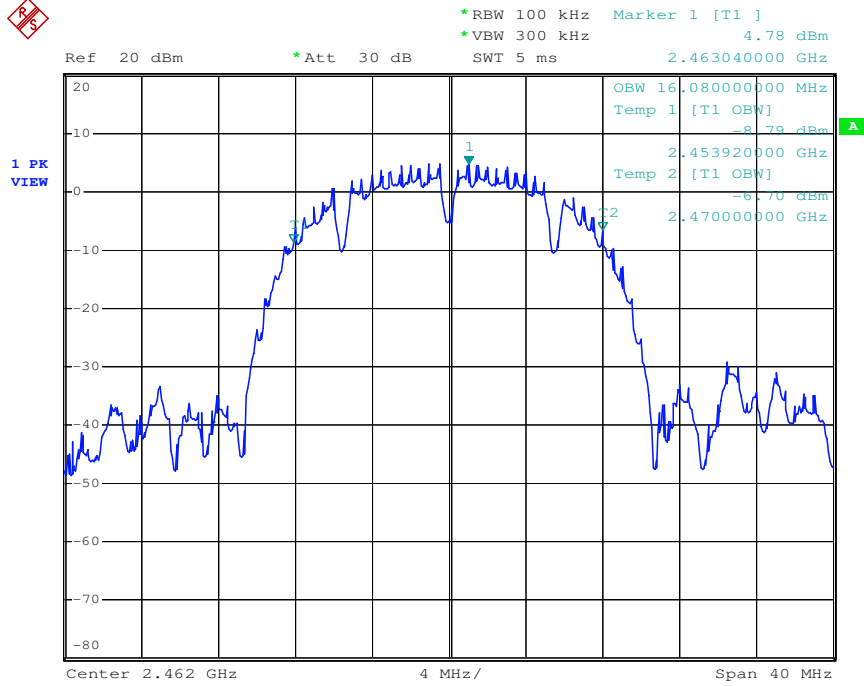

802.11g Low Channel

Antenna B

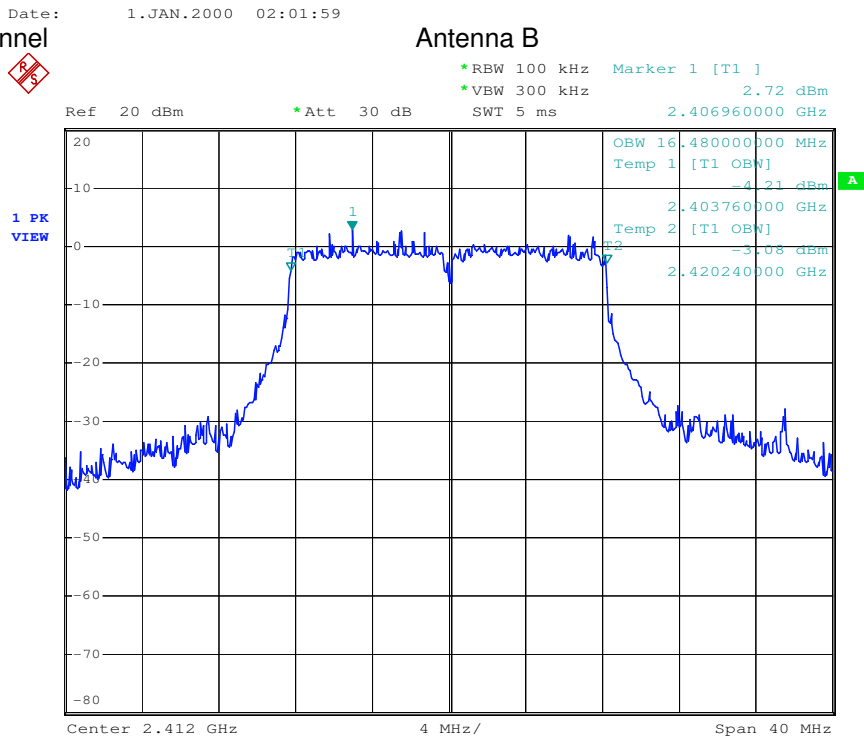

Date: 1.JAN.2000 02:03:37



802.11g Middle Channel

Antenna B

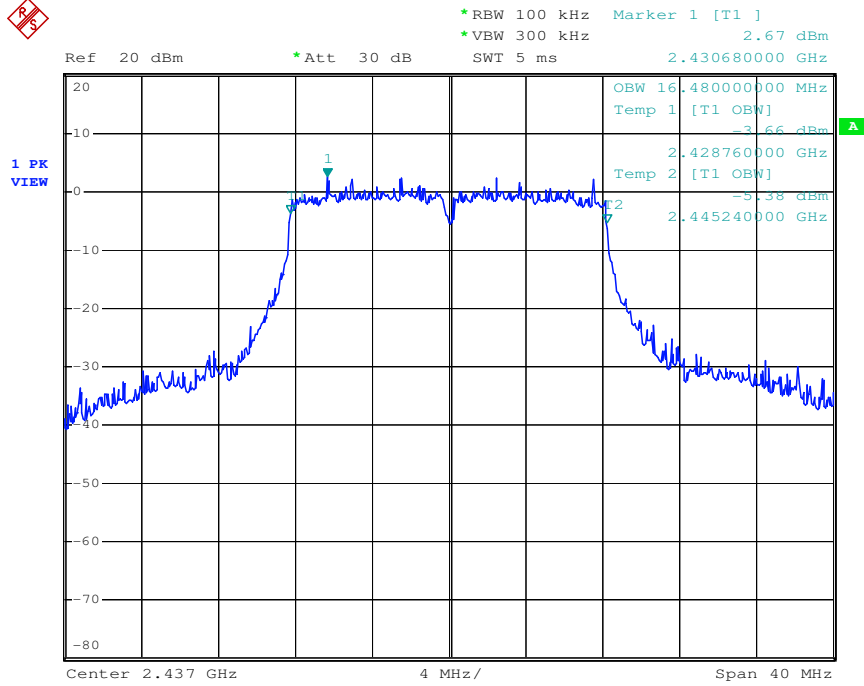

802.11g High Channel

Antenna B

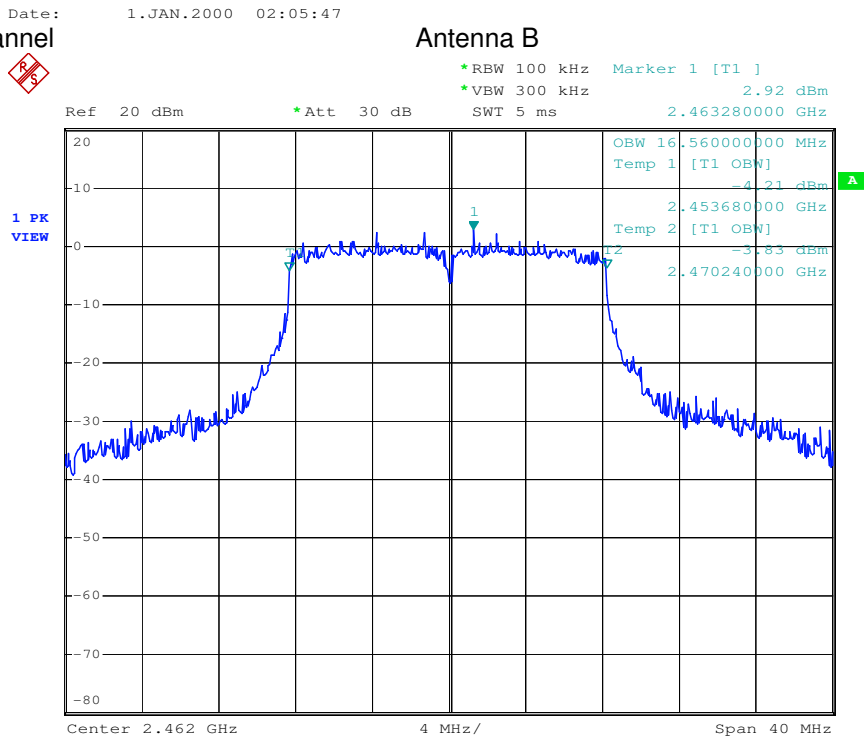

Date: 1.JAN.2000 02:06:40



## **7 Test Setup Photographs**

Refer to the < Appendix D Air 100\_Test Setup photos>.

## **8 EUT Constructional Details**

Refer to the < Appendix B Air 100\_External Photos > & < Appendix C Air 100\_Internal Photos >.

***End of Report***