

1. Introduction of the product

These devices make it possible to efficiently manage and maintain numerous YDRE's in a single golf course.

2. Parts and descriptions

(1) Parent device (The general term Parent device in the text means a BASE ASSY.)

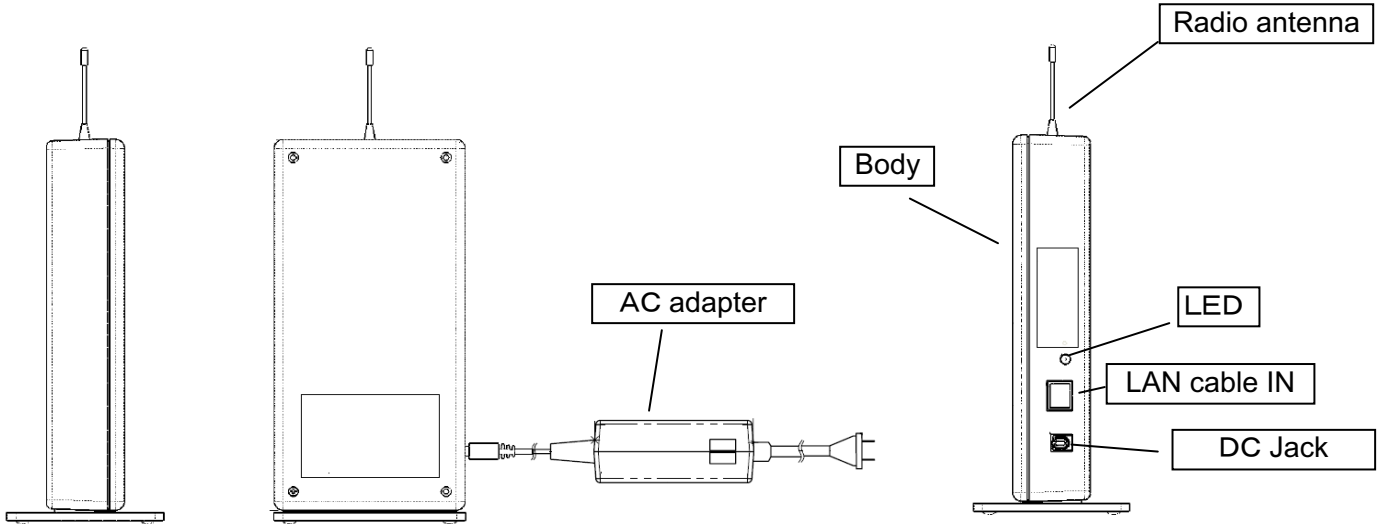

(2) Relay device (The general term Relay device in the text means a TRANSMITTING UNIT.)

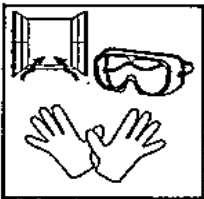
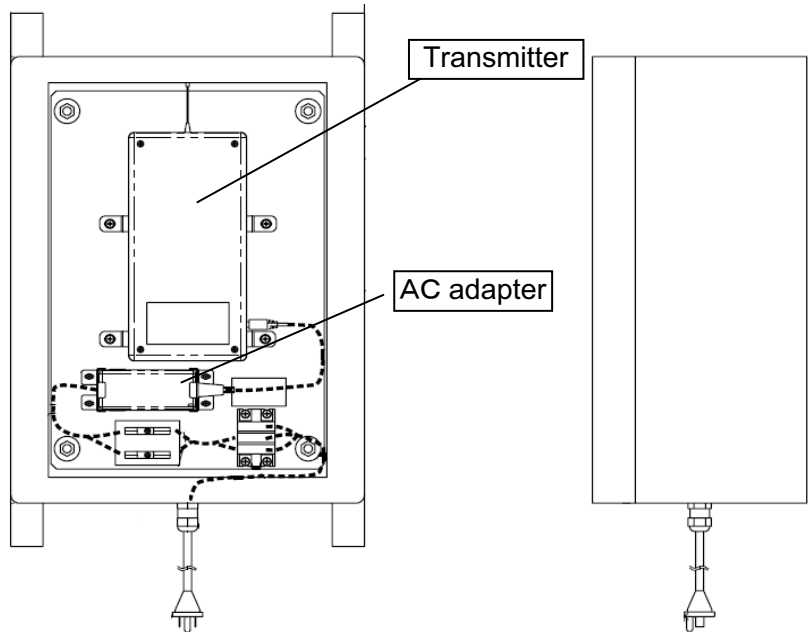

PROTEGEZ-VOUS À L'USINAGE
PROTECT YOURSELF WHEN MACHINING
VORSICHT BEIM BEARBEITEN
PROTEJASE AL MECANIZAR
UTILIZZARE LE PROTEZIONI

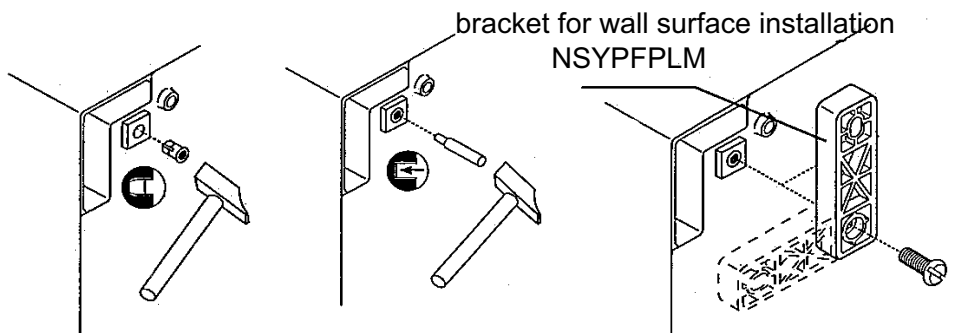

3. Installation

(1) Parent device

Install this device indoors, near the window, and at 150cm or higher from the floor.



Height: 150cm or higher

Floor

NOTICE

- Install this parent device Indoors, near a window, at a height of at least 150cm from the floor.
- Install this device as far away from the metal object as possible, such as metal blinds, glass with steel wires, etc.
- Install this device as far away from 100BASE-T or higher devices as possible.
- Install a lightning guard on the AC outlet.
- GFCI outlet only.

(2) Relay device

Install the relay device on the wall near the entrance to the cart barn, and at least 150cm above the ground.

NOTICE

- Select a location not subject to direct wind or rain which can support the weight of the relay device.
- If the AC power source for the relay device is located outside, use only GFCI and UL50 compliant outlet.
- Do not allow the AC cord to contact the ground. Secure It on the wall using molding.
- If the relay device is to be mounted on a steel wall or a wall with steel reinforcement, place It as far away from the steel reinforcement as possible.
- Keep the relay device away from 100BASE-T or higher devices as possible.

• Installation condition

Mounting on walls Type of wall: Wood

Screw size: $\phi 6 \times 20$ mm or larger

Product weight: 6.3kg

If the product is to be mounted on walls other than wooden walls, use the appropriate mounting screws such as the anchor bolts, etc. (Example: Fisher plug S8 and $\phi 6 \times 60$ mm screws)

Other requirements and cautions Always have an experienced contractor mount this product.

Always have this product mounted at four points.

Don't store anything inside the product.

If the product is to be mounted on walls other than wooden walls, use the appropriate mounting screws such as the anchor bolts, etc.

Even if the wall is made of wood, it may not guarantee sufficient strength depending on the thickness of the wood.

Make sure that you get sufficient mounting strength before actually mounting this device.



Relay device installed near the entrance to the cart barn



Wall mount bracket

※When replacing the fuses inside the relay device:

- Disconnect the AC plug from the outlet.
- Using the key provided, unlock and open the lid.
- Replace the bad fuse with the specified fuse (RetelFuse: 0312. 200MXP).
- Confirm that the fuse is securely placed in the metal holder.
- Replace and lock the lid.

WARNING

- To reduce the danger of fire, use only the electric circuit rated for 5 amps. or higher equipped with a circuit breaker.
- Make sure that none of the AC cords or the LAN cables interfere with pedestrian traffic or other equipment.
- Secure wiring on the walls with molding.
- Do not place wiring on the ground.
- Do not place heaving items on the wiring.
- Do not install wiring where it may be subjected to grease.

WARNING

- Always visually, and by touch, confirm that the AC plug and all system devices are in good working order.
- Do not use this Vehicle Management System under the following conditions:
 - If the AC plug is loose, not secure, or good electric contact is not established.
 - If the AC plug or the system devices feel hotter than usual.
 - The AC plug is bent, corroded, blackened, or showing blue.
 - The wiring of the AC plug or the LAN shows cuts, wear, breakage, or exposure of the conductor.

NOTICE



Do not disassemble the transmitter or the AC adapter.
 Only an authorized Yamaha dealer is authorized to perform maintenance on the internal devices.

FCC WARNING

Changes or modifications not expressly approved by the party responsible for compliance could void the user's authority to operate the equipment.

Note. This equipment has been tested and found to comply with the limits for a Class A digital device , pursuant to part 15 of the FCC Rules. These limits are designed to provide reasonable protection against harmful interference when the equipment is operated in a commercial environment. This equipment generates, uses, and can radiate radio frequency energy and, if not installed and used in accordance with the instruction manual, may cause harmful interference to radio communications, Operation of this equipment in a residential area is likely to cause harmful interference in which case the user will be required to correct the interference at his own expense.

(3) Sample installation on the club house and the cart barn

1. The cart barn stands next to the club house.

Can communicate with the vehicles inside the cart barn and within 100m from the relay device.

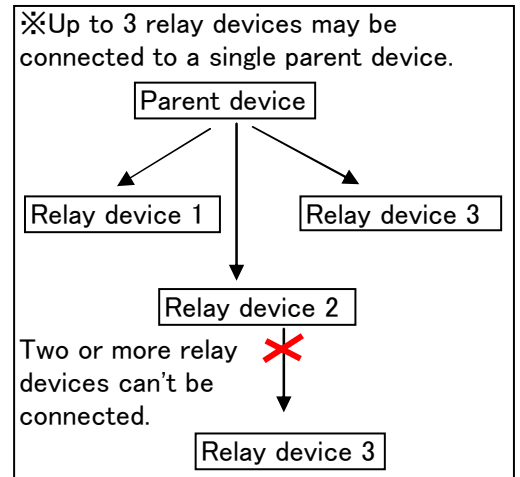
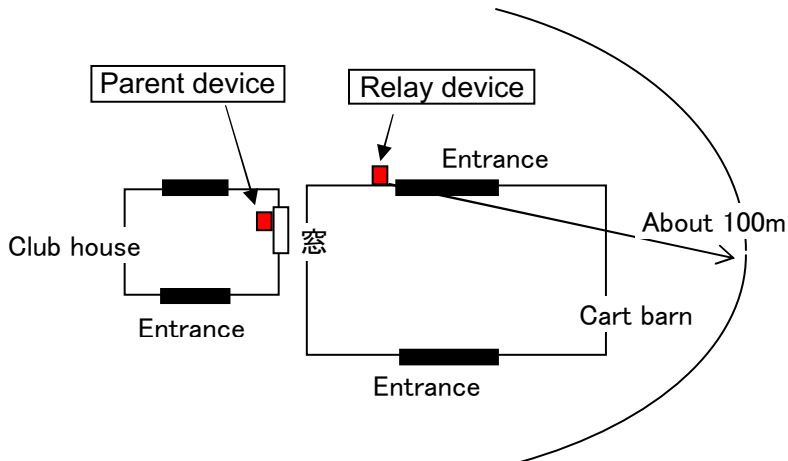

2. The cart barn is somewhat away from the club house.

Communication between the parent and the relay devices can be established up to about 100m straight distance.

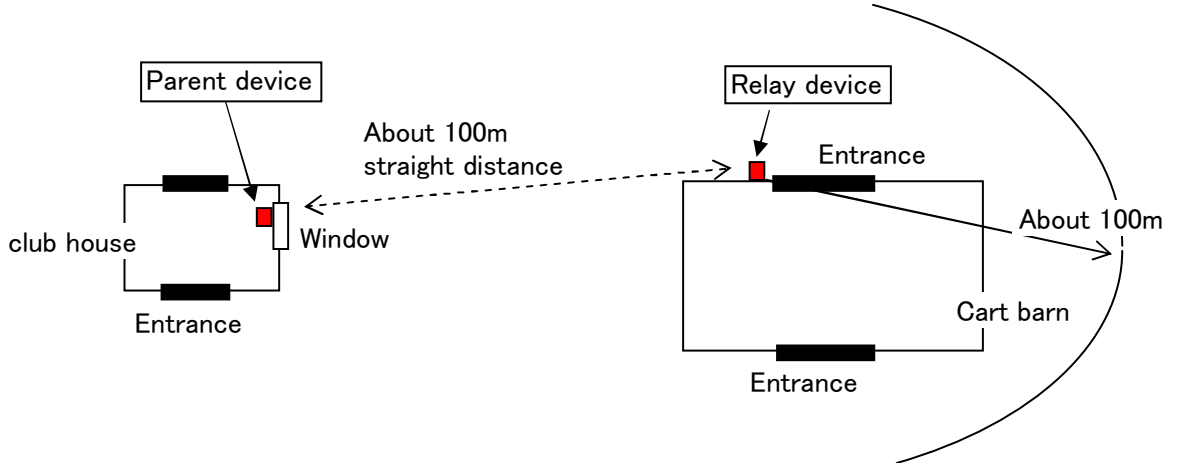

3. The cart barn is beyond 150m from the club house.

Install a parent device housed inside the relay device box at about 100m straight distance from the relay device.

※It would require installation of the LAN cable from the club house and the AC power supply to the parent device.

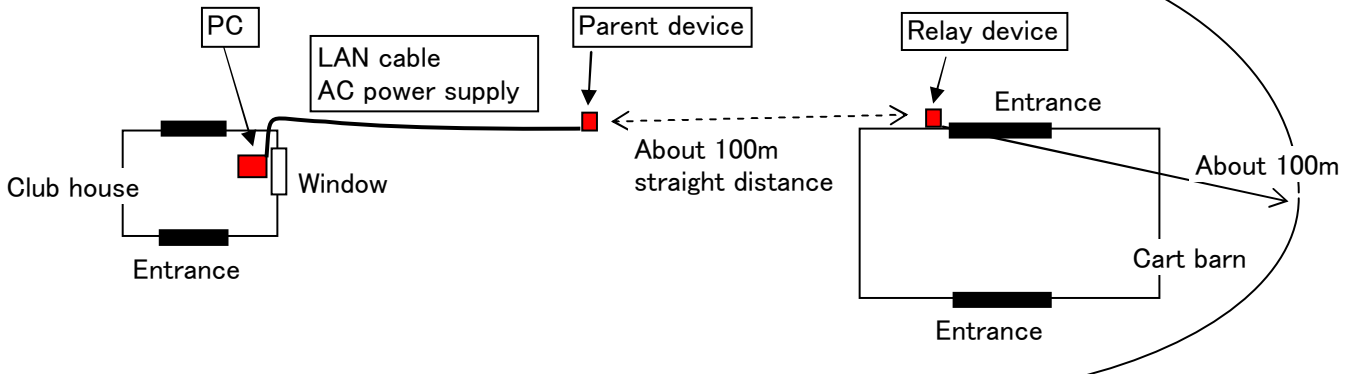

4. Operation

(1) Setting up the Vehicle Management PC

Refer to the separate "Vehicle Management Software Installation Manual".

(2) Registering the vehicles and the relay devices

1. Temporarily place the parent and the relay devices at the possible locations.
2. Install the child devices on all the vehicles. Bring them into the cart barn, and then turn OFF the TOW SW.
※Write down, in advance, the vehicle control numbers and the ID's of the child devices.
3. Run the vehicle management software, and click the "CONFIG" button.

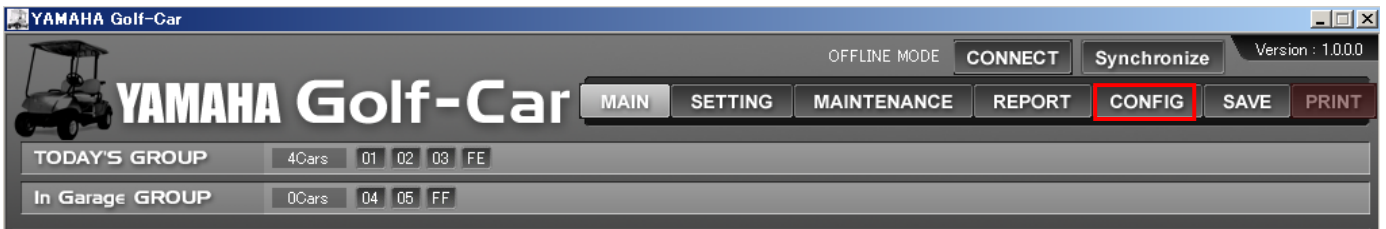

4. First set up the vehicle group.
Click the "Group setting" button.

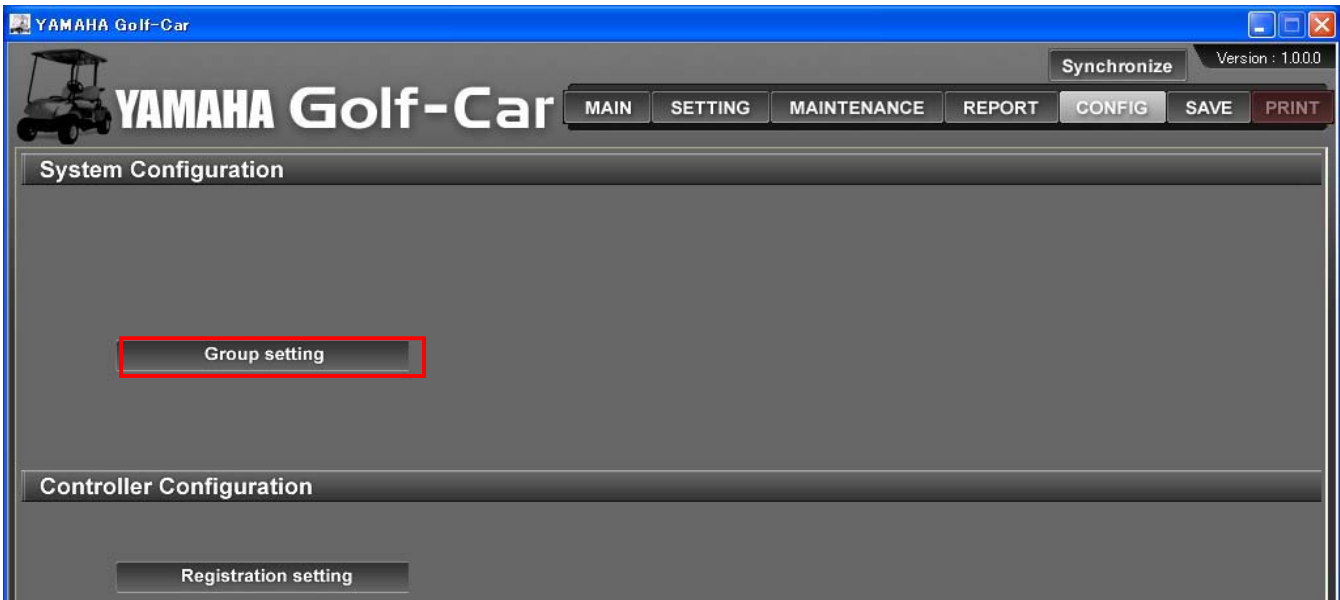

5. Set up the number of groups and the group number.

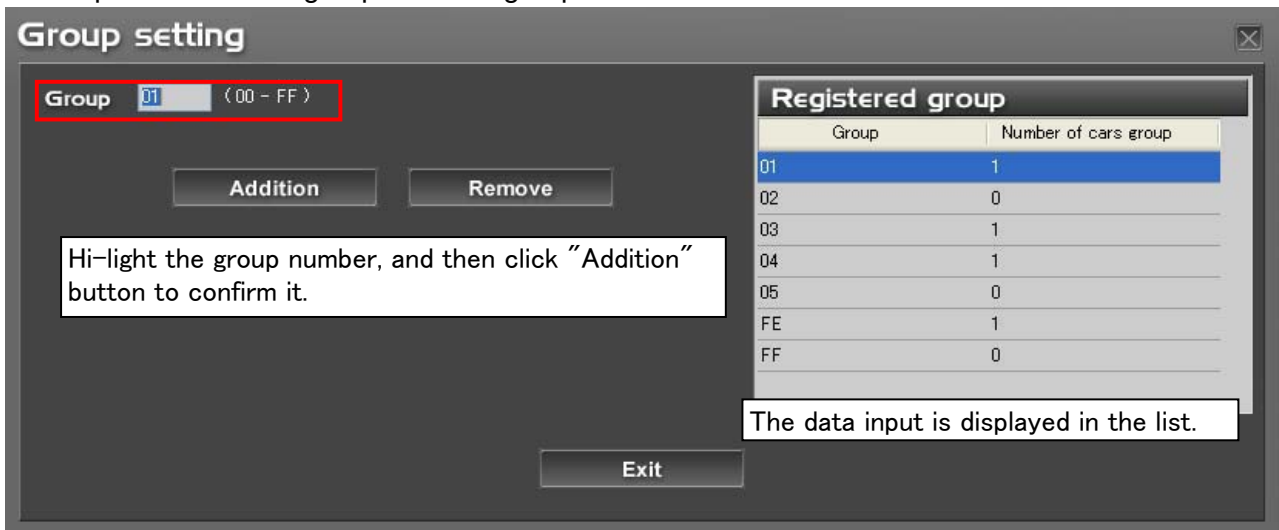

6. Register the vehicles.
 - Select the child device ID and the group, click the "Setting" button, and then turn the TOW SW ON. (Repeat this operation for every one of the vehicles.)
 - In the same way, register the relay device (AP) and connect the AC plug.

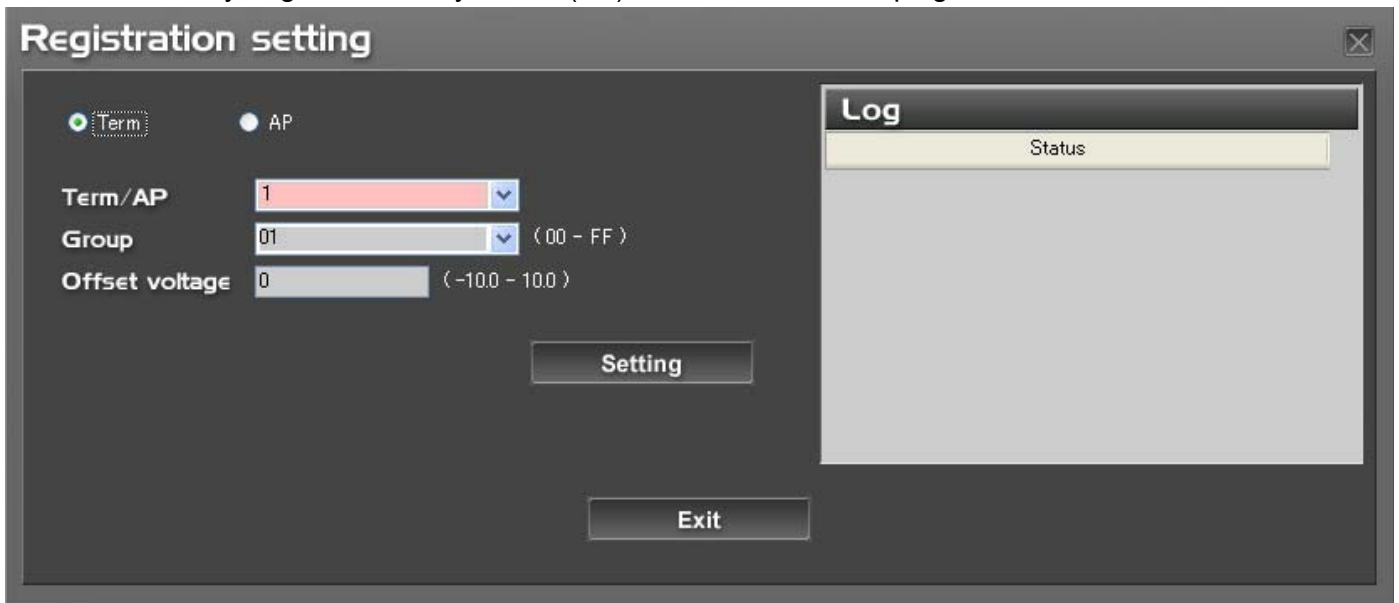

7. Confirm the results of registration.

Return to the "MIAN" screen, verify that all the vehicles are located "In Cart Barn", and then check the level of signal reception of each cart.

※If the signal reception level is low, move the relay device to achieve the signal reception level of 3 or higher.
8. Confirm the level of the signal reception.

Go to the "Communication level confirmation" screen and confirm the level of each cart.

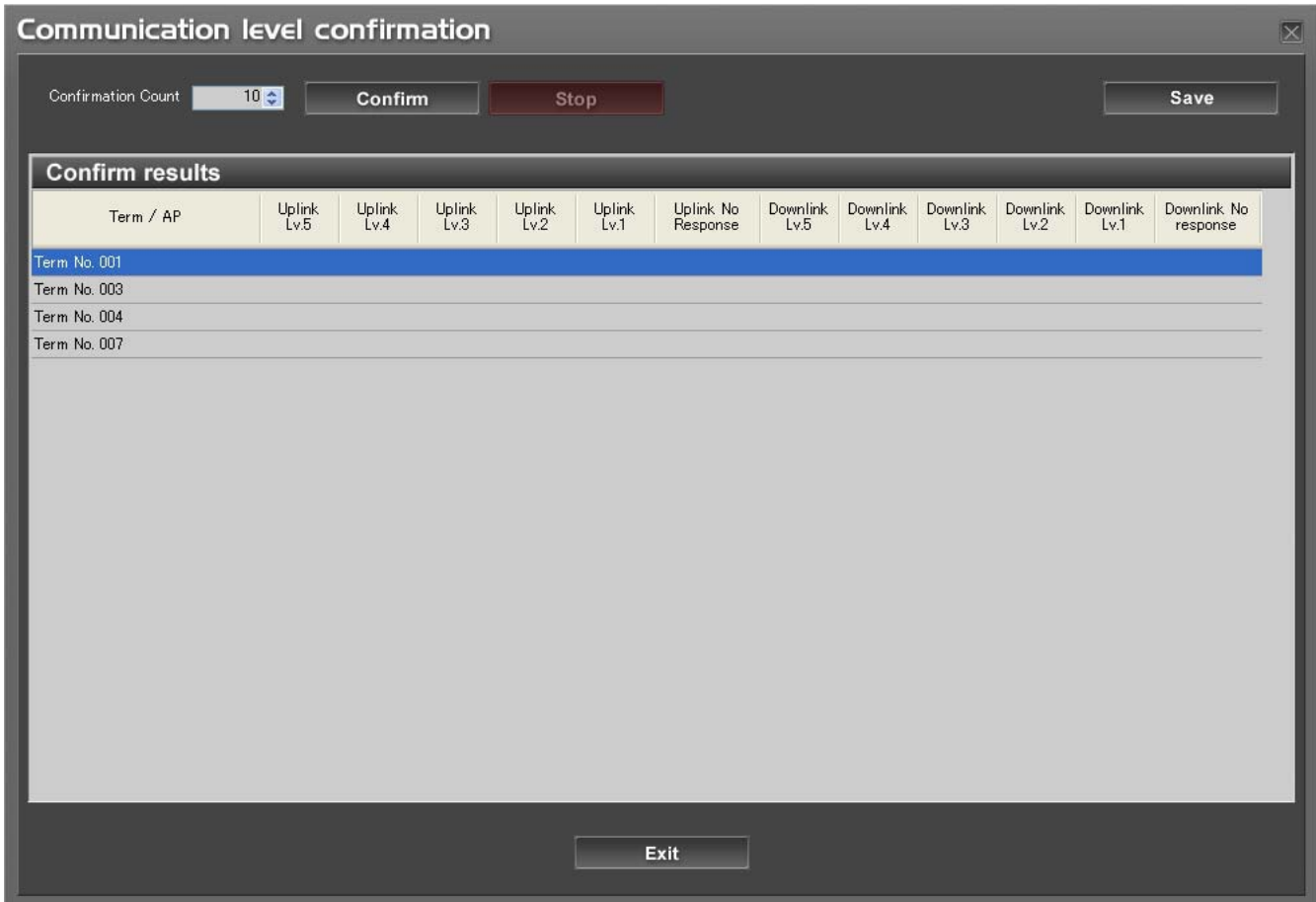

8. End

(3) How to use the Vehicle Management software

Before start of the day

1. Pick up the vehicles to be used for the day in the "SETTING" screen.
2. Confirm on the "MAIN" screen, the status of the battery, abnormality reported by the diagnosis system, and for display of the periodic inspection.
 - ※If the diagnosis reports an abnormality or the system displays the periodic inspection, go to the "MAINTENANCE" screen and confirm the messages, and then perform necessary maintenance to the vehicle.

Start of the day

3. Run vehicle rental operations.
 - Once the player is out on the course, the system moves the vehicle to the "On course" zone.
 - On completion of a round, when the vehicle approaches the club house (in the communication range), the system moves this vehicle to the "In Cart Barn" zone.

Before end of the day

4. Confirm on the "MAIN" screen that all the vehicles have returned to the "In Cart Barn" zone.
5. Check the charge status, diagnosis results, and the display for periodic inspection on each vehicle which was used today.

※If the diagnosis reports an abnormality or the system displays the periodic inspection, go to the "MAINTENANCE" screen and confirm the messages, and then perform necessary maintenance to the vehicle.

(1) Main screen

This is the portal screen for the day-to-day vehicle management.

The screenshot shows the main interface of the Yamaha Golf-Car management software. At the top, there is a status bar with "OFFLINE MODE", "CONNECT", "Synchronize", and "Version: 1.0.0.0". Below this is a navigation menu with buttons for "MAIN", "SETTING", "MAINTENANCE", "REPORT", "CONFIG", "SAVE", and "PRINT". The main area is divided into several sections: "TODAY'S GROUP" (4Cars, 01, 02, 03, FE), "In Garage GROUP" (0Cars, 04, 05, FF), "In Cart Barn" (1Cars, with a "Return" button and "Other" option), and "On Course" (3Cars, with three vehicle icons labeled 01, 02, 03). Callout boxes provide the following descriptions:

- Establish communication with Yamaha Service PC.** (Points to the "CONNECT" button)
- Make a back-up for the vehicle data, repair history, etc.** (Points to the "Synchronize" button)
- Vehicle groups which are in service for this day.** (Points to the "TODAY'S GROUP" section)
- Specify the vehicles to be used for the day.** (Points to the "SETTING" button)
- Displays the status of each vehicle along with the maintenance status.** (Points to the "MAINTENANCE" button)
- Displays the operation history and the maintenance history of all the vehicles, by vehicle and by group.** (Points to the "REPORT" button)
- Register the course information, vehicles, relay device, etc.** (Points to the "CONFIG" button)
- Displays the status of the vehicle in the cart barn.** (Points to the "In Cart Barn" section)
- Displays the vehicles located outside the cart barn (outside the communication range).** (Points to the "On Course" section)

(2) "SETTING" screen

Select the groups of the vehicles which are to be used for the day (drag and drop the groups from "In Garage GROUP" to "TODAY'S GROUP").

※The groups can be sorted by the travel distance, service hours, or by the battery discharge level.

YAMAHA Golf-Car - Microsoft Internet Explorer

Group number **Golf-Car** MAIN SETTING MAINTENANCE REPORT PRINT

TODAY'S GROUP 120Cars 24Cars

In Garage GROUP 80Cars 12Cars Mileage Use time Discharge

No. of vehicles within that group

Average travel distance for the group
Average service hours for the group
Average battery discharge level for the group

(3) "MAINTENANCE" screen

This screen offers the vehicle maintenance status in details.

YAMAHA Golf-Car MAIN SETTING MAINTENANCE REPORT PRINT

List 255Cars

00 2 Running distance 1000km Running time 500hr Total round 125R

DETAILS Charge start 100 Charge end 100 Battery power Battery 49.2V

MAINTENANCE LIST

CHECK Battery liquid
CHECK CHG State of charge terminal
CHECK Pedal check
CHECK Coupler connection state check

Faults

No. ID Content
1 05 TPS reading out of adjustment Trouble shoot
2 15 Battery voltage low Trouble shoot

Maintenance results

Date	Item	Part	Content	Exchange-1	Amount-1	Cost-1	Exchange-2	Amount-2	Cost-2	Work pay	Total cost
2010/00/00	Regular service	Battery	Refilling of water	-	-	-	-	-	-	\$0	\$0
2010/00/00	Regular service	Battery	Damage	JW2-9877	1	\$100	JW2-7794	4	\$20	\$50	\$170

Displays system faults determined by the vehicle controller's self-diagnosis. Click the "Trouble shoot" button to display the repair guide.

Displays the maintenance history. Click the "Addition" button to manually add data.

Click this button if you need to request a repair from Yamaha Service.

Displays the periodic maintenance items corresponding to the vehicle's usage status. When you have completed the maintenance, click the "CHECK" button.

5. Equipment specifications

1. Parent device

Item	Specifications	Remarks
Product model type	JW9-85560-00	
External	220 X 110 X 44mm	
Product weight	About 480g	
Region	USA	
Operating temperatures	-10~60°C	
Operating humidity	85%Rh or lower	No formation of dew
Rated Voltage	DC 12V	Voltage tolerance $\pm 5\%$
Rated Current	0.5A	
Max. power consumption	7W or less	Input of the rated power source voltage and of no
LAN interface	10BASE-T, fixed	
LAN connector	RJ-45	
Communication	Simplex communication system	
Operating frequencies	CH0: 916.2204MHz	On registration : CH0 In service : CH1 (default)
	CH1: 918.0636MHz	
	CH2: 921.7500MHz	
	CH3: 923.5932MHz	
Type of oscillation	PLL synthesizer type	
Type of modulation	2-value FSK	
Coding	NRZ	
Aerial type	Mono-pole antenna	
Electric field strength, send	Less than 93.9dBuV/m	By 3m method
Spurious radiation strength	0.1uW (-40dBm) or lower	Maximum electric power between 0~3GHz at end of antenna
Sensitivity to reception	15dBuVemf or lower	Per standard data at 19200bps, DEV32kHz, and

2. Relay device

Item	Specifications	Remarks
Product model type	JW9-8A2F0-00	
External	430 X 330 X 200mm	
Product weight	About 6.5kg	
Region	USA	
Operating	-10~50°C	
Operating humidity	85%Rh or lower	No formation of dew
Rated Voltage	AC 120V	Voltage tolerance $\pm 10\%$
Consumption of power source	0.1A	
Power source frequency	60Hz	
Max. power consumption	4W or less	Input of the rated power source voltage and of no signal at the antenna
Communication	Simplex communication system	
Operating frequencies	CH0: 916.2204MHz	On registration : CH0 In service : CH1 (default)
	CH1: 918.0636MHz	
	CH2: 921.7500MHz	
	CH3: 923.5932MHz	
Type of oscillation	PLL synthesizer type	
Type of modulation	2-value FSK	
Coding	NRZ	
Aerial type	Mono-pole antenna	
Electric field strength, send	Less than 93.9dBuV/m	By 3m method
Spurious radiation strength	0.1uW (-40dBm) or lower	Maximum electric power between 0~3GHz at end of
Sensitivity to reception	15dBuVemf or lower	Per standard data at 19200bps, DEV32kHz, and