

FCC Radio Test Report

FCC ID: YJYCLUE

This report concerns (check one): Original Grant Class II Change

Project No. : 1602C039
Equipment : 4G LTE Digital Mobile Telephone
Model Name : C630
Applicant : Shanghai Feixun Communication Co.,Ltd.
Address : No.3666, Sixian Rd., Songjiang District, Shanghai,
P.R.China

Date of Receipt : Feb. 19, 2016
Date of Test : Feb. 19, 2016 ~ Mar. 16, 2016
Issued Date : Mar. 17, 2016
Tested by : BTL Inc.

Technical Engineer :

Shawn Xiao
(Shawn Xiao)

Authorized Signatory :

Steven Lu
(Steven Lu)

B T L I N C .

No.3,Jinshagang 1st Road, Shixia,Dalang Town, Dongguan,
Guangdong, China.

TEL: +86-769-8318-3000 FAX: +86-769-8319-6000

Declaration

BTL represents to the client that testing is done in accordance with standard procedures as applicable and that test instruments used has been calibrated with standards traceable to international standard(s) and/or national standard(s).

BTL's reports apply only to the specific samples tested under conditions. It is manufacture's responsibility to ensure that additional production units of this model are manufactured with the identical electrical and mechanical components. **BTL** shall have no liability for any declarations, inferences or generalizations drawn by the client or others from **BTL** issued reports.

BTL's report must not be used by the client to claim product certification, approval, or endorsement by NVLAP, NIST, or any agency of the Federal Government.

This report is the confidential property of the client. As a mutual protection to the clients, the public and **BTL-self**, extracts from the test report shall not be reproduced except in full with **BTL's** authorized written approval.

BTL's laboratory quality assurance procedures are in compliance with the **ISO Guide17025** requirements, and accredited by the conformity assessment authorities listed in this test report.

Limitation

For the use of the authority's logo is limited unless the Test Standard(s)/Scope(s)/Item(s) mentioned in this test report is (are) included in the conformity assessment authorities acceptance respective.

Table of Contents	Page
REPORT ISSUED HISTORY	5
1 . CERTIFICATION	6
2 . SUMMARY OF TEST RESULTS	7
2.1 TEST FACILITY	8
2.2 MEASUREMENT UNCERTAINTY	8
3 . GENERAL INFORMATION	9
3.1 GENERAL DESCRIPTION OF EUT	9
3.2 DESCRIPTION OF TEST MODES AND TEST CONDITION	10
3.3 BLOCKDIGRAMSHOWINGTHECONFIGURATIONOFSYSTEMTESTED	11
3.4 DESCRIPTION OF SUPPORT UNITS	11
4 . TEST RESULT	12
4.1 OUTPUT POWER MEASUREMENT	12
4.1.1 LIMIT	12
4.1.2 TEST PROCEDURE	12
4.1.3 TESTSETUP LAYOUT	13
4.1.4 TEST DEVIATION	13
4.1.5 TEST RESULTS	13
4.2 OCCUPIED BANDWIDTH MEASUREMENT	14
4.2.1 TEST PROCEDURE	14
4.2.2 TEST SETUP LAYOUT	14
4.2.3 TEST DEVIATION	14
4.2.4 TEST RESULTS	14
4.3 CONDUCTED EMISSIONS MEASUREMENT	15
4.3.1 LIMIT	15
4.3.2 TEST PROCEDURES	15
4.3.3 TESTSETUP LAYOUT	15
4.3.4 TESTDEVIATION	15
4.3.5 TEST RESULTS	15
4.4 RADIATED EMISSIONS MEASUREMENT	16
4.4.1 LIMIT	16
4.4.2 TEST PROCEDURES	16
4.4.3 TESTSETUP LAYOUT	16
4.4.4 TESTDEVIATION	16
4.4.5 TEST RESULTS	16
4.5 BAND EDGE MEASUREMENT	17
4.5.1 LIMIT	17

Table of Contents	Page
4.5.2 TEST PROCEDURES	17
4.5.3 TESTSETUP LAYOUT	17
4.5.4 TESTDEVIATION	17
4.5.5 TEST RESULTS	17
4.6 PEAK TO AVERAGE RATIO MEASUREMENT	18
4.6.1 LIMIT	18
4.6.2 TEST PROCEDURES	18
4.6.3 TESTSETUP LAYOUT	18
4.6.4 TESTDEVIATION	18
4.6.5 TEST RESULTS	18
4.7 FREQUENCY STABILITY MEASUREMENT	19
4.7.1 LIMIT	19
4.7.2 TEST PROCEDURES	19
4.7.3 TESTSETUP LAYOUT	19
4.7.4 TESTDEVIATION	19
4.7.5 TEST RESULTS	19
5. LIST OF MEASUREMENT EQUIPMENTS	20
6. EUT TEST PHOTO	22
ATTACHMENT A - OUTPUT POWER	25
ATTACHMENT B - OCCUPIED BANDWIDTH	28
ATTACHMENT C - CONDUCTED EMISSIONS	32
ATTACHMENT D - RADIATED EMISSION	35
ATTACHMENT E - BAND EDGE	51
ATTACHMENT F - PEAK TO AVERAGE RATIO	54
ATTACHMENT G - FREQUENCY STABILITY	57

REPORT ISSUED HISTORY

Issued No.	Description	Issued Date
BTL-FCCP-4-1602C039	Original Issue.	Mar. 17, 2016

1. CERTIFICATION

Equipment : 4G LTE Digital Mobile Telephone
Brand Name : PHICOMM, FEIXUN
Model Name : C630
Applicant : Shanghai Feixun Communication Co.,Ltd.
Manufacturer : Shanghai Feixun Communication Co.,Ltd.
Address : No.3666,Sixian Rd.,Songjiang District,Shanghai,P.R.China
Date of Test : Feb. 19, 2016 ~ Mar. 16, 2016
Test Sample : Engineering Sample
Standard(s) : 47 CFR FCC Part 22 Subpart H
47 CFR FCC Part 2
ANSI/TIA-603-D-2010
KDB 971168 D01 Power Meas License Digital Systems v02r02

The above equipment has been tested and found compliance with the requirement of the relative standards by BTL Inc.

The test data, data evaluation, and equipment configuration contained in our test report (Ref No. BTL-FCCP-4-1602C039) were obtained utilizing the test procedures, test instruments, test sites that has been accredited by the Authority of TAF according to the ISO-17025 quality assessment standard and technical standard(s).

Test result included in this report is only for the GSM850 and WCDMA Band V part.

2. SUMMARY OF TEST RESULTS

Test procedures according to the technical standard(s):

FCC Part 22 Subpart H& Part 2			
Standard(s) Section	Test Item	Judgment	Tested By
2.1046 22.913(a)	Radiated power	PASS	Robert Luo
2.1046 22.913(a)	Conducted Output Power	PASS	Allen Li
2.1049(h) 22.917(a)	Occupied Bandwidth	PASS	Allen Li
2.1051 22.917(a)	Conducted Spurious Emissions	PASS	Allen Li
2.1053 22.917(a)	Radiated Spurious Emissions	PASS	Robert Luo
22.917(a)	Band Edge Measurements	PASS	Allen Li
-	Peak To Average Ratio	PASS	Allen Li
2.1055 22.355	Frequency Stability	PASS	Allen Li

NOTE:

(1) "N/A" denotes test is not applicable to this device.

2.1 TEST FACILITY

The test facilities used to collect the test data in this report is at the location of No.3, Jinshagang 1st Road, Shixia, Dalang Town, Dongguan, Guangdong, China.

BTL's test firm number for FCC: 319330

2.2 MEASUREMENT UNCERTAINTY

Where relevant, the following measurement uncertainty levels have been estimated for tests performed on the EUT as specified in CISPR 16-4-2. The BTL measurement uncertainty is less than the CISPR 16-4-2 U_{CISPR} requirement.

The reported uncertainty of measurement $y \pm U$, where expanded uncertainty U is based on a standard uncertainty multiplied by a coverage factor of $k=2$, providing a level of confidence of approximately **95%**.

A. Radiated Measurement :

Test Site	Method	Measurement Frequency Range	Ant. H / V	U,(dB)
DG-CB03 (3m)	CISPR	9KHz~30MHz	V	3.79
		9KHz~30MHz	H	3.57
		30MHz ~ 200MHz	V	3.82
		30MHz ~ 200MHz	H	3.78
		200MHz ~ 1,000MHz	V	4.10
		200MHz ~ 1,000MHz	H	4.06
		1GHz~18GHz	V	3.12
		1GHz~18GHz	H	3.68
		18GHz~40GHz	V	4.15
		18GHz~40GHz	H	4.14

Note: Unless specifically mentioned, the uncertainty of measurement has not been taken into account to declare the compliance or non-compliance to the specification.

3. GENERAL INFORMATION

3.1 GENERAL DESCRIPTION OF EUT

Equipment	4G LTE Digital Mobile Telephone	
Brand Name	PHICOMM, FEIXUN	
Model Name	C630	
Model Difference	N/A	
Modulation Type	GSM/GPRS	GMSK
	EDGE	GMSK, 8PSK
	WCDMA	Uplink: BPSK Downlink: QPSK
	WCDMA(HSDPA/HSUPA)	16QAM/64QAM
Operation Frequency	GSM /EDGE/GPRS	824.2 ~ 848.8 MHz
	WCDMA Band 5	826.4 ~ 846.6 MHz
Max. ERP Power	GSM	26.46dBm
	EDGE	25.19dBm
	WCDMA	18.45dBm
Antenna Type	Fixed Internal Antenna	
Antenna Gain	-0.47dBi	
Hardware Version	C630LwLA_0000_5.0_1.0T06_0229_SH	
Software Version	C630LwLA_MB_V1.0	
IMEI No.	867985021362672	
Power Source	#1 DC voltage supplied from AC/DC adapter. #2 Supplied from USB port. #3 Supplied from rechargeable Li-Polymer battery.	
Power Rating	Please refer to note 2	

Note:

- For a more detailed features description, please refer to the manufacturer's specifications or the user's manual.
- The EUT contains following accessory devices.

Product	Brand	Model	Description
Adapter	N/A	RD0501000-USBA-18MG	I/P: 100-240V~50/60Hz, 0.25A MAX O/P: 5V --- 1000mA
Battery	N/A	BL-F33	3.8V, 2300mAh, 8.74Wh
USB Cable	N/A	N/A	100cm shielded cable with core

3.2 DESCRIPTION OF TEST MODES AND TEST CONDITION

Pre-Scan has been conducted to determine the worst-case mode from all possible combinations between available modulations, data rates, XYZ axis and antenna ports
 The worst case was found when positioned on X-plane for ERP and X-axis for radiated emission.
 Following channel(s) was (were) selected for the final test as listed below:

GSM MODE			
Test Item	Available Channel	Tested Channel	Mode
ERP	128 to 251	128, 190, 251	GSM, EDGE
Conducted Output Power	128 to 251	128, 190, 251	GSM, EDGE
Occupied Bandwidth	128 to 251	128, 190, 251	GSM, EDGE
Conducted Emission	128 to 251	190	GSM, EDGE
Radiated Emission	128 to 251	190	GSM, EDGE
Band Edge	128 to 251	128, 251	GSM, EDGE
Peak to Average Ratio	128 to 251	128, 190, 251	GSM, EDGE
Frequency Stability	128 to 251	190	GSM, EDGE

WCDMA MODE			
Test Item	Available Channel	Tested Channel	Mode
ERP	4132 to 4233	4132, 4182, 4233	WCDMA
Conducted Output Power	4132 to 4233	4132, 4182, 4233	WCDMA
Conducted Emission	4132 to 4233	4182	WCDMA
Radiated Emission	4132 to 4233	4182	WCDMA
Band Edge	4132 to 4233	4132, 4233	WCDMA
Peak to Average Ratio	4132 to 4233	4132, 4182, 4233	WCDMA
Frequency Stability	4132 to 4233	4182	WCDMA

Note: This device was tested under all bandwidths, RB configurations and modulations. The worst case was found in **QPSK** modulation.

EUT TEST CONDITIONS:

Test Item	Environmental Conditions	Test Voltage
ERP	24°C, 63%RH	AC 120V/60Hz
Conducted Output Power	25°C, 65%RH	AC 120V/60Hz
Occupied Bandwidth	25°C, 65%RH	AC 120V/60Hz
Conducted Emission	25°C, 65%RH	AC 120V/60Hz
Radiated Emission	24°C, 63%RH	AC 120V/60Hz
Band Edge	25°C, 65%RH	AC 120V/60Hz
Peak to Average Ratio	25°C, 65%RH	AC 120V/60Hz
Frequency Stability	25°C, 65%RH	AC 120V/60Hz

3.3 BLOCK DIAGRAM SHOWING THE CONFIGURATION OF SYSTEM TESTED

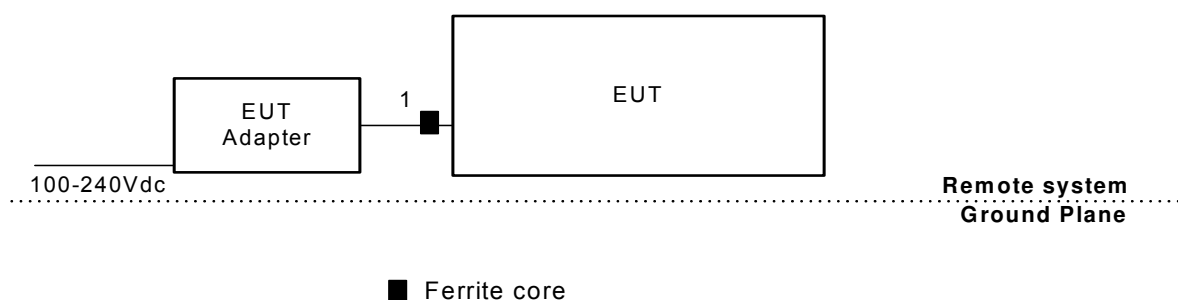

3.4 DESCRIPTION OF SUPPORT UNITS

The EUT has been tested as an independent unit together with other necessary accessories or support units. The following support units or accessories were used to form a representative test configuration during the tests.

Item	Equipment	Mfr/Brand	Model/Type No.	FCC ID	Series No.
-	-	-	-	-	-

Item	Shielded Type	Ferrite Core	Length	Note
1	YES	YES	1m	USB cable

4. TEST RESULT

4.1 OUTPUT POWER MEASUREMENT

4.1.1 LIMIT

Mobile / Portable station are limited to 7 watts e.r.p.

4.1.2 TEST PROCEDURE

EIRP/ERP:

1. All measurements were done at low, middle and high operational frequency range. RBW and VBW setting:
Set the RBW \geq OBW.
Set VBW $\geq 3 \times$ RBW.
Set span $\geq 2 \times$ RBW
Sweep time=auto couple
Detector=peak
Ensure that the number of measurement points \geq span/RBW
Trace mode=max hold
Allow trace to fully stabilize
Use the peak marker function to determine the peak amplitude level
2. Substitution method is used for E.I.R.P measurement. In the semi-anechoic chamber, EUT placed on the 0.8m height of Turn Table, rotated the table around 360 degrees to search the maximum radiation power and receiver antenna shall be rotated vertical and horizontal polarization and moved height from 1m to 4m to find the maximum polar radiated power. The "Read Value" is the spectrum reading the maximum power value.
3. The substitution horn antenna is substituted for EUT at the same position and signals generator export the CW signal to the substitution antenna via a tx cable. Rotated the Turn Table and moved receiving antenna to find the maximum radiation power. Adjust output power level of S.G to get a Value of spectrum reading equal to "Read Value" of step b. Record the power level of S.G
5. E.R.P power can be calculated form E.I.R.P power by subtracting the gain of Integral, E.R.P power=E.I.P.R power-2.15dBi.

Conducted Power:

The EUT was set up for the maximum power with GSM, GPRS, EDGE and WCDMA link data modulation and link up with simulator. Set the EUT to transmit under low, middle and high channel and record the power level shown on simulator.

4.1.3 TESTSETUP LAYOUT

ERP Power Measurement

Below 1G

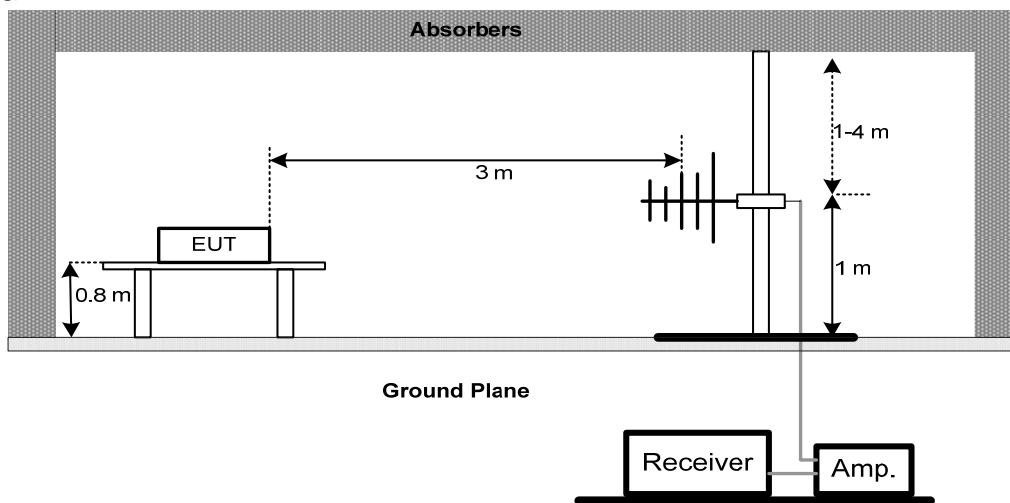

Above 1G

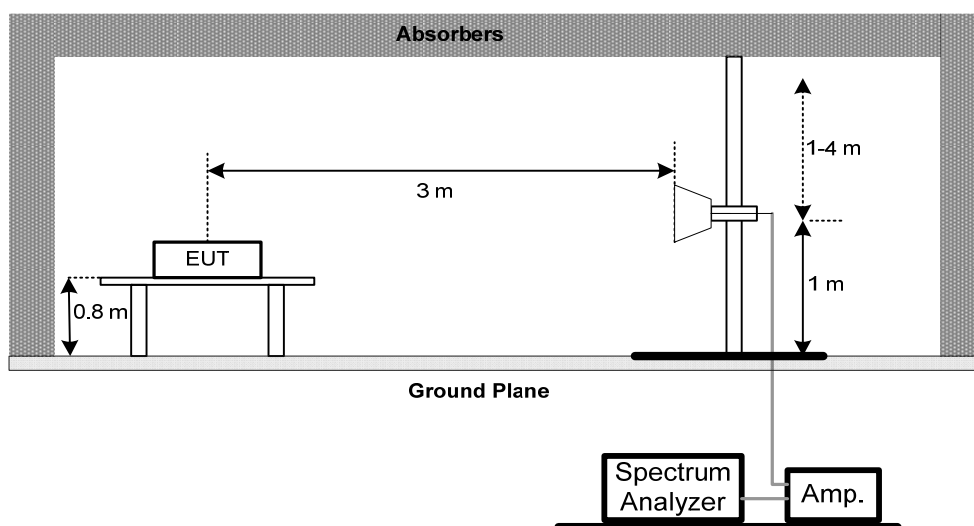

Conducted Power Measurement

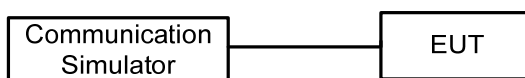

4.1.4 TEST DEVIATION

No deviation

4.1.5 TEST RESULTS

Please refer to the Attachment A.

4.2 OCCUPIED BANDWIDTH MEASUREMENT

4.2.1 TEST PROCEDURE

The EUT makes a call to the communication simulator. All measurements were done at low, middle and high operational frequency range. The communication simulator station system controlled a EUT to export maximum output power under transmission mode and specific channel frequency. Use OBW measurement function of Spectrum analyzer to measure 99 % occupied bandwidth and 26dB bandwidth.

4.2.2 TEST SETUP LAYOUT

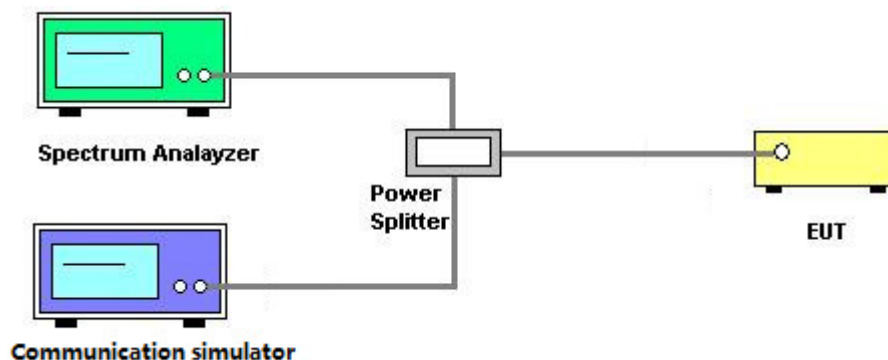

4.2.3 TEST DEVIATION

No deviation

4.2.4 TEST RESULTS

Please refer to the Attachment B.

4.3 CONDUCTED EMISSIONS MEASUREMENT

4.3.1 LIMIT

The power of any emission outside of the authorized operating frequency ranges must be attenuated below the transmitting power (P) by a factor of at least $43 + 10 \log(P)$ dB. The emission limit equal to -13dBm.

4.3.2 TEST PROCEDURES

1. The testing follows FCC KDB 971168 v02r02 Section 6.0.
2. The EUT was connected to spectrum analyzer and system simulator via a power divider.
3. The band edges of low and high channels for the highest RF powers were measured. Set $RBW \geq 1\%$ EBW in the 1MHz band immediately outside and adjacent to the band edge.
4. Set spectrum analyzer with RMS detector.
5. The RF fundamental frequency should be excluded against the limit line in the operating frequency band.
6. The limit line is derived from $43+10\log(P)$ dB below the transmitter power P(Watts)

$$=P(W)-[43+10\log(P)](dB)$$

$$=[30+10\log(P)](dBm)-[43+10\log(P)](dB)$$

$$=-13dBm$$

4.3.3 TESTSETUP LAYOUT

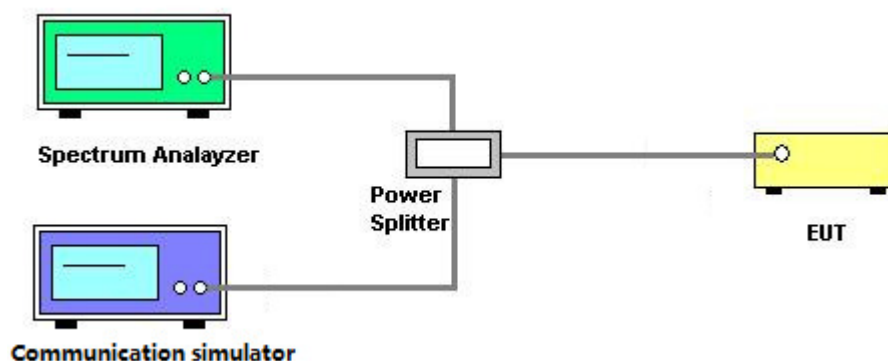

4.3.4 TESTDEVIATION

No deviation

4.3.5 TEST RESULTS

Please refer to the Attachment C.

4.4 RADIATED EMISSIONS MEASUREMENT

4.4.1 LIMIT

The power of any emission outside of the authorized operating frequency ranges must be attenuated below the transmitting power (P) by a factor of at least $43 + 10 \log(P)$ dB. The emission limit equal to -13dBm.

4.4.2 TEST PROCEDURES

1. Substitution method is used for E.I.R.P measurement. In the semi-anechoic chamber, EUT placed on the 0.8m height of Turn Table, rotated the table around 360 degrees to search the maximum radiation power and receiver antenna shall be rotated vertical and horizontal polarization and moved height from 1m to 4m to find the maximum polar radiated power. The "Read Value" is the spectrum reading the maximum power value.
2. The substitution horn antenna is substituted for EUT at the same position and signals generator export the CW signal to the substitution antenna via a TX cable. Rotated the Turn Table and moved receiving antenna to find the maximum radiation power. Adjust output power level of S.G to get a Value of spectrum reading equal to "Read Value " of step a. Record the power level of S.G
3. EIRP = Output power level of S.G – TX cable loss + Antenna gain of substitution horn.
4. E.R.P power can be calculated form E.I.R.P power by subtracting the gain of dipole, E.R.P power = E.I.P.R power - 2.15dBi.
5. The resolution bandwidth and video bandwidth of test receiver/spectrum analyzer is 1MHz/3MHz.

4.4.3 TESTSETUP LAYOUT

This test setup layout is the same as that shown in **section 4.1.3**.

4.4.4 TESTDEVIATION

No deviation

4.4.5 TEST RESULTS

Please refer to the Attachment D.

4.5 BAND EDGE MEASUREMENT

4.5.1 LIMIT

A Power of any emission outside of the authorized operating frequency ranges must be attenuated below the transmitting power (P) by a factor of at least $43 + 10 \log(P)$ dB. In the 1 MHz bands immediately outside and adjacent to the frequency block a resolution bandwidth of at least one percent of the emission bandwidth of the fundamental emission of the transmitter may be employed.

4.5.2 TEST PROCEDURES

1. All measurements were done at low and high operational frequency range.
2. The center frequency of spectrum is the band edge frequency and span is 1MHz. RB of the spectrum is 3kHz and VB of the spectrum is 10kHz (GSM/GPRS/EDGE).
3. The center frequency of spectrum is the band edge frequency and span is 5MHz. RB of the spectrum is 100kHz and VB of the spectrum is 300kHz (WCDMA).
4. The center frequency of spectrum is the band edge frequency and span is 1MHz. RB of the spectrum is 13kHz and VB of the spectrum is 51kHz (LTE Bandwidth 1.4MHz).
5. The center frequency of spectrum is the band edge frequency and span is 1MHz. RB of the spectrum is 30kHz and VB of the spectrum is 100kHz (LTE Bandwidth 3MHz).
6. The center frequency of spectrum is the band edge frequency and span is 1MHz. RB of the spectrum is 100kHz and VB of the spectrum is 300kHz (LTE Bandwidth 5MHz/10MHz).
7. Record the max trace plot into the test report.

4.5.3 TESTSETUP LAYOUT

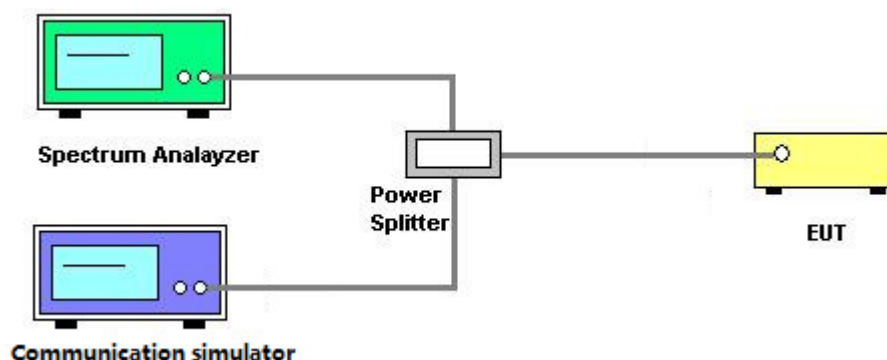

4.5.4 TESTDEVIATION

No deviation

4.5.5 TEST RESULTS

Please refer to the Attachment E.

4.6 PEAK TO AVERAGE RATIO MEASUREMENT

4.6.1 LIMIT

In measuring transmissions in this band using an average power technique, the peak to-average ratio (PAR) of the transmission may not exceed 13 dB.

4.6.2 TEST PROCEDURES

1. Set resolution/measurement bandwidth \geq signal's occupied bandwidth;
2. Set the number of counts to a value that stabilizes the measured CCDF curve;
3. Record the maximum PAPR level associated with a probability of 0.1%.

4.6.3 TESTSETUP LAYOUT

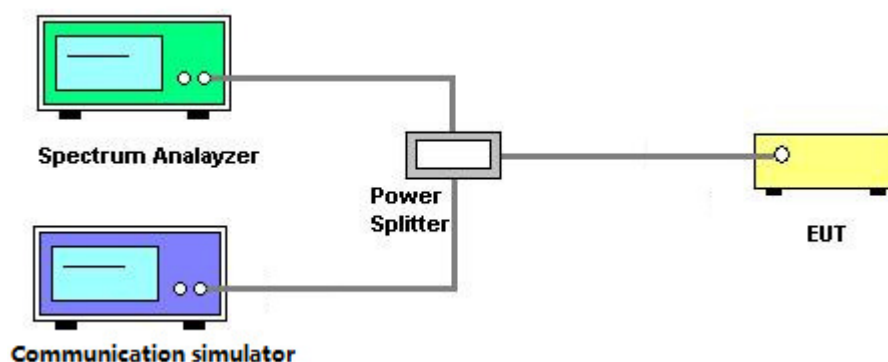

4.6.4 TESTDEVIATION

No deviation

4.6.5 TEST RESULTS

Please refer to the Attachment F.

4.7 FREQUENCY STABILITY MEASUREMENT

4.7.1 LIMIT

1.5 ppm is for base and fixed station. 2.5 ppm is for mobile station.

4.7.2 TEST PROCEDURES

1. Device is placed at the oven room. The oven room could control the temperatures and humidity. Power warm up is at least 15 min and power applied should perform before recording frequency error.
2. EUT is connected the external power supply to control the DC input power. The test voltage range is from minimum to maximum working voltage. Each step shall be record the frequency error rate.
3. The temperature range step is 10 degrees in this test items. All temperature levels shall be hold the $\pm 0.5^{\circ}\text{C}$ during the measurement testing. The each temperature step shall be at least 0.5 hours, consider the EUT could be test under the stability condition.
4. The frequency error was recorded frequency error from the communication simulator.

4.7.3 TESTSETUP LAYOUT

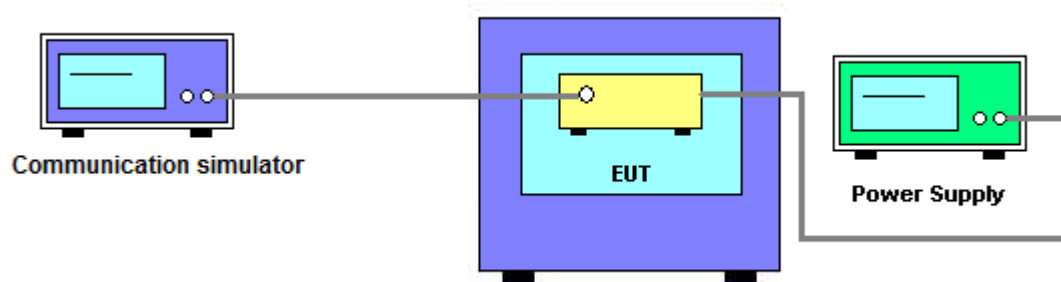

4.7.4 TESTDEVIATION

No deviation

4.7.5 TEST RESULTS

Please refer to the Attachment G.

5. LIST OF MEASUREMENT EQUIPMENTS

Radiated Emission & ERP or EIRP Measurement					
Item	Kind of Equipment	Manufacturer	Type No.	Serial No.	Calibrated until
1	Antenna	Schwarbeck	VULB9160	9160-3232	Mar. 28, 2016
2	Amplifier	HP	8447D	2944A09673	Nov. 09, 2016
3	Receiver	AGILENT	N9038A	MY52130039	Oct. 11, 2016
4	Test Cable	emci	LMR-400(30MHz-1GHz)	C-01	Jun. 28, 2016
5	Controller	CT	SC100	N/A	N/A
6	Antenna	ETS	3115	00075789	Mar. 28, 2016
7	Amplifier	Agilent	8449B	3008A02274	Nov. 01, 2016
8	Test Cable	emci	EMC104-SM-SM-10000(1GHz-26.5GHz)	C-68	Jun. 28, 2016
9	Broad-Band Horn Antenna	Schwarzbeck	BBHA 9170	9170319	Mar. 28, 2016
10	Microwave Preamplifier With Adaptor	EMC INSTRUMENT	EMC2654045	980039 & HA01	Mar. 28, 2016
11	Measurement Software	Farad	EZ-EMC Ver.NB-03A1-01	N/A	N/A
12	Wireless Communication Test Set	(8960 Series) Agilent	E5515C	MY48364183	Mar. 28, 2016
13	Band Reject Filter	Wairwright Instruments Gmbh	WRCG 824/849-810/86 3-60/9SS	7	Mar. 03, 2017
14	HighPass Filter	Wairwright Instruments Gmbh Gmbh	WHK 1.5/15G-10ST	11	Jul. 06, 2016
15	HighPass Filter	Wairwright Instruments Gmbh	WHK 3.1/18G-10SS	24	Mar. 03, 2017
16	HighPass Filter	ZHPF-M1000-4000-1	WHK 1000-4000MHz	B2015073762	Aug. 05, 2016
17	HighPass Filter	ZHPF-M3-12.75G-3869	WHK 3000-12750MHz	B2015073763	Aug. 05, 2016
18	HighPass Filter	ZHPF-M6-18G-1727	WHK 6000-18000MHz	B2015073764	Aug. 05, 2016
19	Active Loop Antenna	R&S	HFH2-Z2	830749/020	Sep. 07, 2016

Conducted Emission & Band Edge & Occupied Bandwidth Measurement					
Item	Kind of Equipment	Manufacturer	Type No.	Serial No.	Calibrated until
1	EXA Spectrum Analyzer	Agilent	N9010A	MY50520044	Mar. 28, 2016
2	Wireless Communication Test Set	(8960 Series)Agilent	E5515C	MY48364183	Mar. 28, 2016
3	wideband radio communication tester	R&S	CMW500	152372	Jan. 29, 2017
4	POWER SPLITTER	Mini-Circuits	ZFRSC-123-S+	331000910-1	Mar. 17, 2016
5	Test Cable	N/A	RG316	Cable4-001	Jul. 15, 2016
6	Test Cable	N/A	RG316	Cable4-002	Jul. 15, 2016
7	Spectrum Analyzer	R&S	FSP 40	100185	Oct. 11, 2016

Frequency Stability Measurement					
Item	Kind of Equipment	Manufacturer	Type No.	Serial No.	Calibrated until
1	Wireless Communication Test Set	(8960 Series)Agilent	E5515C	MY48364183	Mar. 28, 2016
2	wideband radio communication tester	R&S	CMW500	152372	Jan. 29, 2017
3	POWER SPLITTER	Mini-Circuits	ZFRSC-123-S+	331000910-1	Mar. 17, 2016
4	Test Cable	N/A	RG316	Cable4-001	Jul. 15, 2016
5	Const Temp. & Humidity Chamber	GIANT FORCE	ITH-225-20-S	IAB0309-001	Dec. 04, 2016
6	DC power supply	GW Instek	GPC-30300N	EK880675	Oct. 13, 2016

Remark: "N/A" denotes no model name, serial no. or calibration specified.
 All calibration period of equipment list is one year.

6. EUT TEST PHOTO

Radiated Measurement Photos 9KHz to 30MHz



**Radiated Measurement Photos
Below 1GHz**

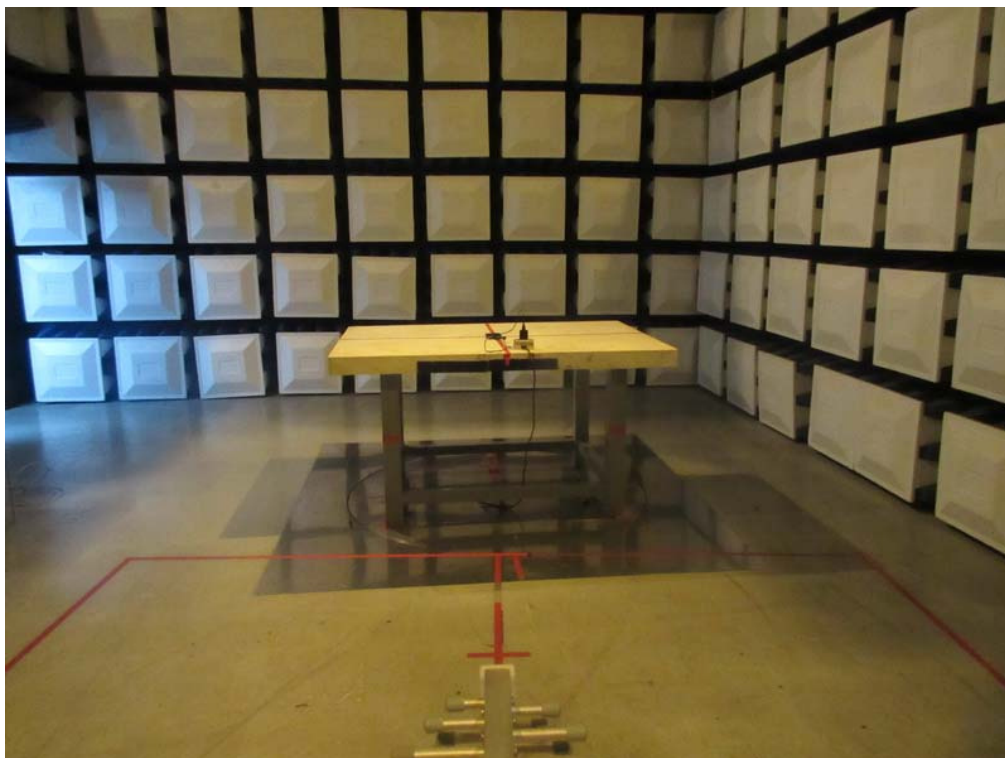

**Radiated Measurement Photos
Above 1GHz**

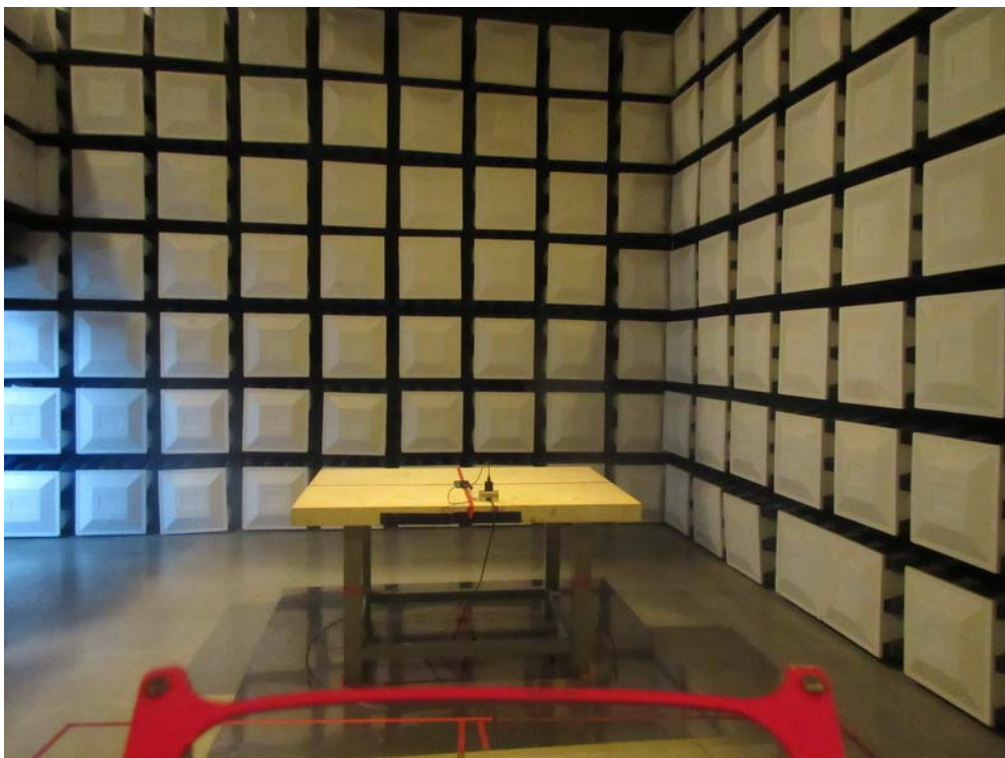
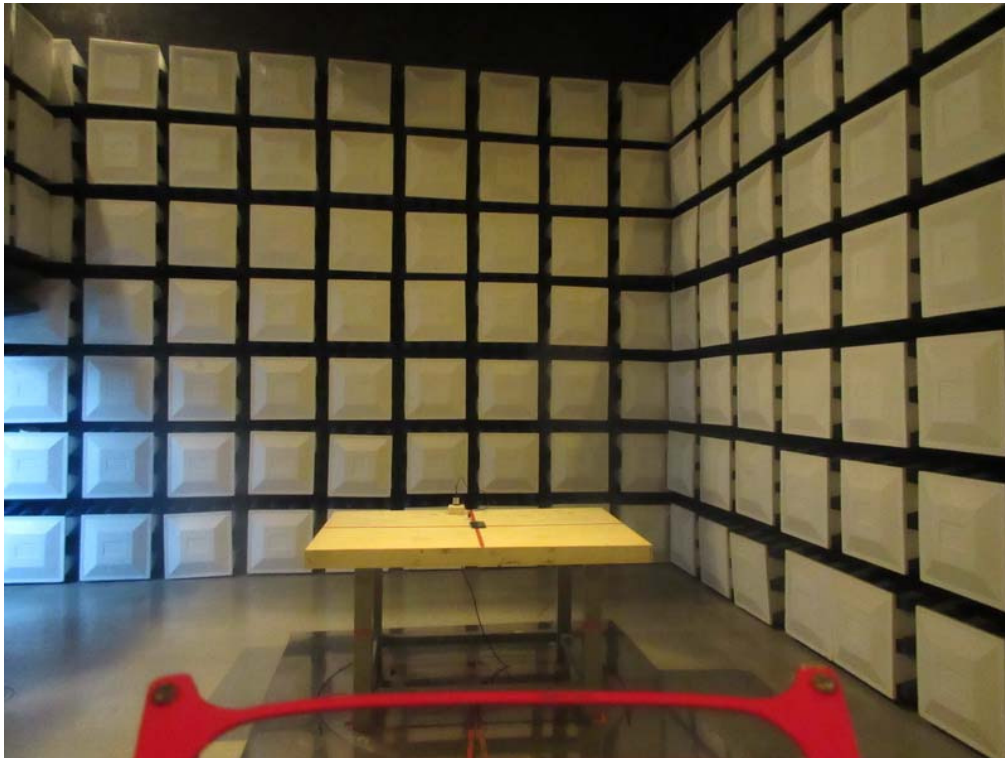

ATTACHMENT A - OUTPUT POWER

Conducted Power:

GSM850 (Capsensor Off)	Burst Conducted Power (dBm)			Average Power (dBm)		
	128CH	190CH	251CH	128CH	190CH	251CH
	824.2MHz	836.6MHz	848.8MHz	824.2MHz	836.6MHz	848.8MHz
GSM (CS)	32.42	32.43	32.40	23.23	23.24	23.21
GPRS/EDGE (GMSK)	32.41	32.39	32.39	23.22	23.20	23.20
	30.43	30.45	30.42	24.30	24.32	24.29
	28.58	28.56	28.28	24.16	24.14	23.86
	26.49	26.47	26.39	23.31	23.29	23.21
EDGE (8PSK)	26.53	26.39	26.37	17.34	17.20	17.18
	26.45	26.35	26.31	20.32	20.22	20.18
	26.36	26.27	26.22	21.94	21.85	21.80
	24.76	24.72	24.68	21.58	21.54	21.50

Band	WCDMA V(Capsensor Off)		
Tx Channel	4132CH	4182CH	4233CH
Rx Channel	4357CH	4407CH	4458CH
Frequency	826.4MHz	836.4MHz	846.6MHz
RMC 12.2K	22.96	23.03	22.73
RMC 64K	22.95	23.02	22.70
RMC 144K	22.97	23.01	22.67
RMC 384K	22.95	22.98	23.02
HSDPA Subtest-1	21.80	22.05	21.81
HSDPA Subtest-2	21.82	22.10	21.80
HSDPA Subtest-3	21.33	21.46	21.43
HSDPA Subtest-4	21.33	21.53	21.31
HSUPA Subtest-1	21.41	22.03	21.56
HSUPA Subtest-2	20.49	20.66	21.02
HSUPA Subtest-3	20.59	21.07	19.99
HSUPA Subtest-4	21.45	21.54	21.71
HSUPA Subtest-5	21.96	22.05	21.84

E. R.P Power

GSM850					
Plane	Channel	Frequency (MHz)	GSM ERP(dBm)	EDGE ERP(dBm)	Polarization (H/V)
X	128	824.2	26.46	25.19	H
	190	836.6	25.67	11.45	H
	251	848.8	26.12	24.31	H
	128	824.2	20.78	18.18	V
	190	836.6	17.97	17.27	V
	251	848.8	18.10	16.23	V

WCDMA Band V				
Plane	Channel	Frequency (MHz)	ERP(dBm)	Polarization (H/V)
X	4132	826.4	18.45	H
	4182	836.4	18.09	H
	4233	846.6	18.25	H
	4132	826.4	10.99	V
	4182	836.4	10.36	V
	4233	846.6	9.38	V

ATTACHMENT B - OCCUPIED BANDWIDTH

GSM850					
GSM			EDGE		
Channel	Frequency (MHz)	99% Occupied Bandwidth (MHz)	Channel	Frequency (MHz)	99% Occupied Bandwidth (MHz)
128	824.2	0.244	128	824.2	0.245
190	836.6	0.245	190	836.6	0.244
251	848.8	0.245	251	848.8	0.240
Channel	Frequency (MHz)	26dB Bandwidth (MHz)	Channel	Frequency (MHz)	26dB Bandwidth (MHz)
128	824.2	0.317	128	824.2	0.311
190	836.6	0.314	190	836.6	0.313
251	848.8	0.318	251	848.8	0.307

Spectrum Plot

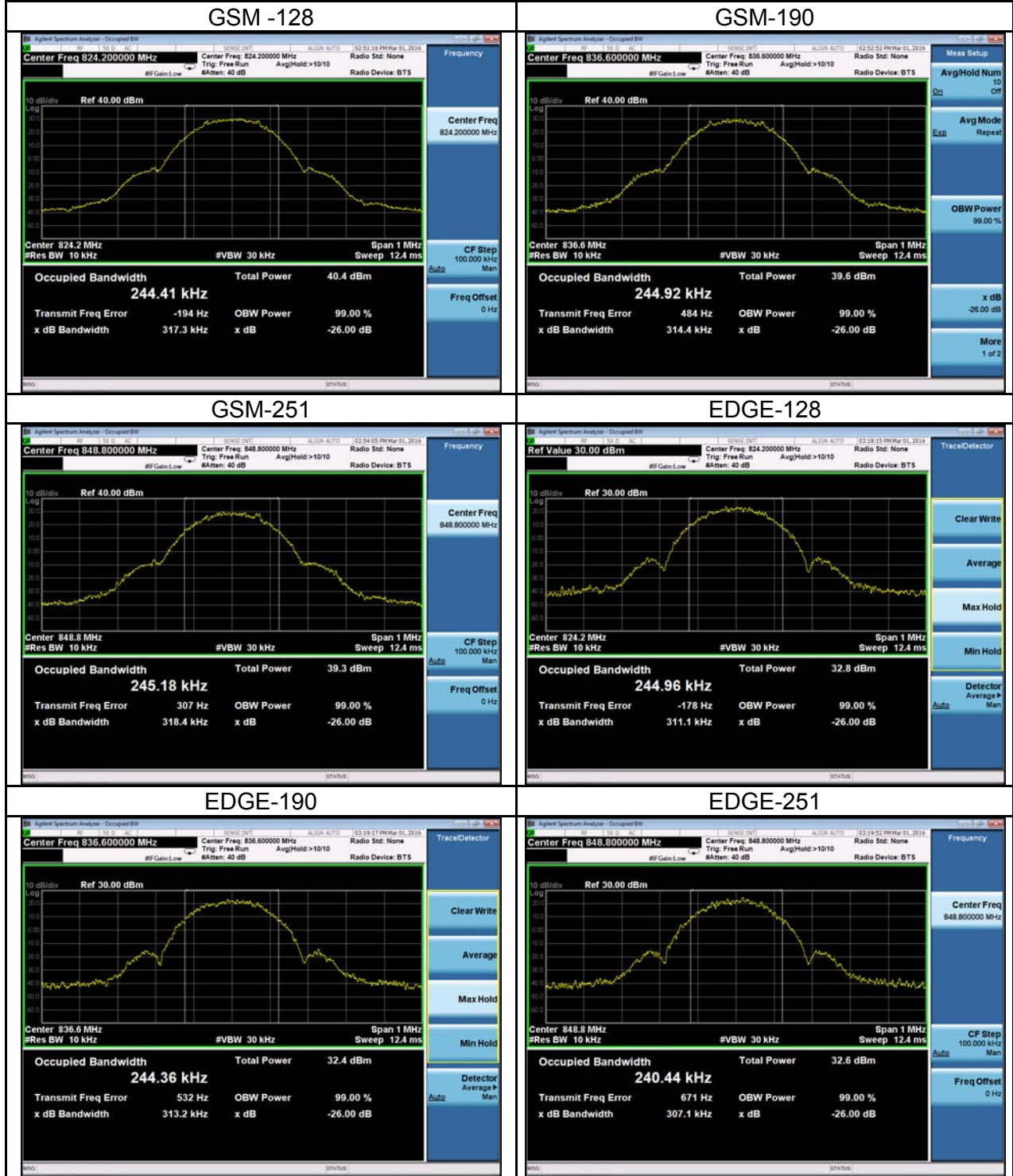

WCDMA Band V					
Channel	Frequency (MHz)	99% Occupied Bandwidth (MHz)	Channel	Frequency (MHz)	26dB Bandwidth (MHz)
4132	826.4	4.154	4132	826.4	4.729
4182	836.4	4.145	4182	836.4	4.727
4233	846.6	4.144	4233	846.6	4.739



ATTACHMENT C – CONDUCTED EMISSIONS

GSM850			
GSM		GSM	
Channel	Frequency(MHz)	Channel	Frequency(MHz)
190	836.6	190	836.6
<p>Date: 16.MAR.2016 14:03:21</p>		<p>Date: 16.MAR.2016 14:07:14</p>	
GSM		EDGE	
Channel	Frequency(MHz)	Channel	Frequency(MHz)
190	836.6	190	836.6
<p>Date: 16.MAR.2016 14:03:43</p>		<p>Date: 16.MAR.2016 14:03:43</p>	
EDGE		EDGE	
Channel	Frequency(MHz)	Channel	Frequency(MHz)
190	836.6	190	836.6
<p>Date: 16.MAR.2016 14:07:22</p>		<p>Date: 16.MAR.2016 14:07:22</p>	

WCDMA Band V

Channel	Frequency(MHz)	Channel	Frequency(MHz)
4182	836.4	4182	836.4

Channel	Frequency(MHz)		
4182	836.4	-	-

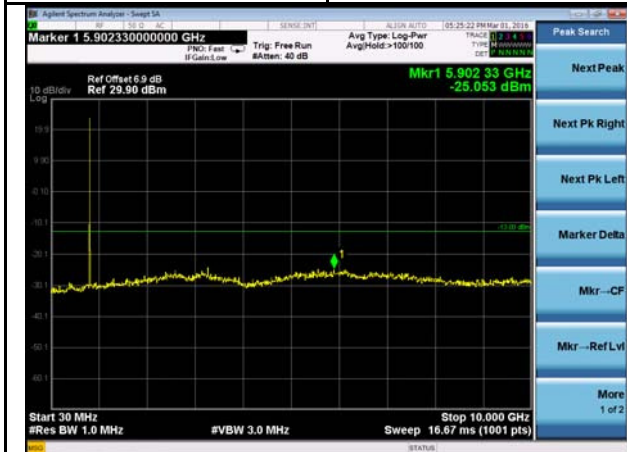

-

ATTACHMENT D - RADIATED EMISSION

Test Mode:	GSM850_TX CH190_GSM
------------	---------------------

Frequency (MHz)	Ant 0°/90°	Read level dBuV/m	Factor (dB)	Measured(FS) (dBuV/m)	Limit (dBuV/m)	Margin (dB)	Note
0.0114	0°	13.21	24.84	38.05	126.47	-88.41	AVG
0.0114	0°	14.52	24.84	39.36	146.47	-107.10	PK
0.0252	0°	6.08	23.97	30.05	119.58	-89.53	AVG
0.0252	0°	8.15	23.97	32.12	139.58	-107.46	PK
0.0351	0°	3.16	23.34	26.50	116.70	-90.19	AVG
0.0351	0°	5.33	23.34	28.67	136.70	-108.02	PK
0.0537	0°	1.62	22.33	23.95	113.00	-89.06	AVG
0.0537	0°	2.74	22.33	25.07	133.00	-107.94	PK
0.5042	0°	19.57	19.81	39.38	73.55	-34.17	QP
1.9573	0°	23.42	19.50	42.92	69.54	-26.62	QP

Frequency (MHz)	Ant 0°/90°	Read level dBuV/m	Factor (dB)	Measured(FS) (dBuV/m)	Limit (dBuV/m)	Margin (dB)	Note
0.0127	90°	13.59	24.30	37.89	125.53	-87.64	AVG
0.0127	90°	14.81	24.30	39.11	145.53	-106.42	PK
0.0233	90°	7.57	24.09	31.66	120.26	-88.60	AVG
0.0233	90°	8.62	24.09	32.71	140.26	-107.55	PK
0.0439	90°	5.35	22.79	28.14	114.75	-86.62	AVG
0.0439	90°	6.56	22.79	29.35	134.75	-105.41	PK
0.0526	90°	1.59	22.35	23.94	113.18	-89.25	AVG
0.0526	90°	2.37	22.35	24.72	133.18	-108.47	PK
0.6242	90°	22.43	20.20	42.63	71.70	-29.07	QP
2.0552	90°	24.26	19.47	43.73	69.54	-25.81	QP

Test Mode:	GSM850_TX CH190_EDGE
------------	----------------------

Frequency (MHz)	Ant 0°/90°	Read level dBuV/m	Factor (dB)	Measured(FS) (dBuV/m)	Limit (dBuV/m)	Margin (dB)	Note
0.0126	0°	13.79	24.77	38.56	125.60	-87.04	AVG
0.0126	0°	14.34	24.77	39.11	145.60	-106.49	PK
0.0212	0°	6.53	24.22	30.75	121.08	-90.32	AVG
0.0212	0°	8.61	24.22	32.83	141.08	-108.24	PK
0.0367	0°	3.76	23.24	27.00	116.31	-89.31	AVG
0.0367	0°	5.28	23.24	28.52	136.31	-107.79	PK
0.0535	0°	1.43	22.33	23.76	113.04	-89.28	AVG
0.0535	0°	2.57	22.33	24.90	133.04	-108.14	PK
0.5031	0°	19.75	19.81	39.56	73.57	-34.01	QP
1.9576	0°	23.19	19.50	42.69	69.54	-26.85	QP

Frequency (MHz)	Ant 0°/90°	Read level dBuV/m	Factor (dB)	Measured(FS) (dBuV/m)	Limit (dBuV/m)	Margin (dB)	Note
0.0113	90°	13.42	24.30	37.72	126.54	-88.82	AVG
0.0113	90°	14.32	24.30	38.62	146.54	-107.92	PK
0.0258	90°	7.54	23.93	31.47	119.37	-87.90	AVG
0.0258	90°	8.46	23.93	32.39	139.37	-106.98	PK
0.0415	90°	5.33	22.94	28.27	115.24	-86.97	AVG
0.0415	90°	6.93	22.94	29.87	135.24	-105.37	PK
0.0564	90°	1.79	22.27	24.06	112.58	-88.52	AVG
0.0564	90°	2.38	22.27	24.65	132.58	-107.93	PK
0.6238	90°	22.34	20.20	42.54	71.70	-29.17	QP
2.0525	90°	24.43	19.47	43.90	69.54	-25.64	QP

Test Mode:	WCDMA Band V_TX CH4182
------------	------------------------

Frequency (MHz)	Ant 0°/90°	Read level dBuV/m	Factor (dB)	Measured(FS) (dBuV/m)	Limit (dBuV/m)	Margin (dB)	Note
0.0121	0°	13.87	24.80	38.67	125.95	-87.28	AVG
0.0121	0°	14.39	24.80	39.19	145.95	-106.76	PK
0.0273	0°	6.55	23.84	30.39	118.88	-88.49	AVG
0.0273	0°	8.19	23.84	32.03	138.88	-106.85	PK
0.0348	0°	3.48	23.36	26.84	116.77	-89.93	AVG
0.0348	0°	5.39	23.36	28.75	136.77	-108.02	PK
0.0537	0°	1.63	22.33	23.96	113.00	-89.05	AVG
0.0537	0°	2.76	22.33	25.09	133.00	-107.92	PK
0.5034	0°	19.62	19.81	39.43	73.57	-34.14	QP
1.9516	0°	23.41	19.50	42.91	69.54	-26.63	QP

Frequency (MHz)	Ant 0°/90°	Read level dBuV/m	Factor (dB)	Measured(FS) (dBuV/m)	Limit (dBuV/m)	Margin (dB)	Note
0.0125	90°	13.38	24.30	37.68	125.67	-87.99	AVG
0.0125	90°	14.77	24.30	39.07	145.67	-106.60	PK
0.0258	90°	7.42	23.93	31.35	119.37	-88.02	AVG
0.0258	90°	8.53	23.93	32.46	139.37	-106.91	PK
0.0437	90°	5.64	22.80	28.44	114.79	-86.36	AVG
0.0437	90°	6.38	22.80	29.18	134.79	-105.62	PK
0.0529	90°	1.51	22.34	23.85	113.14	-89.28	AVG
0.0529	90°	2.36	22.34	24.70	133.14	-108.43	PK
0.6265	90°	22.52	20.20	42.72	71.67	-28.94	QP
2.0532	90°	24.26	19.47	43.73	69.54	-25.81	QP

Test Mode: GSM850_TX CH190_GSM

Vertical

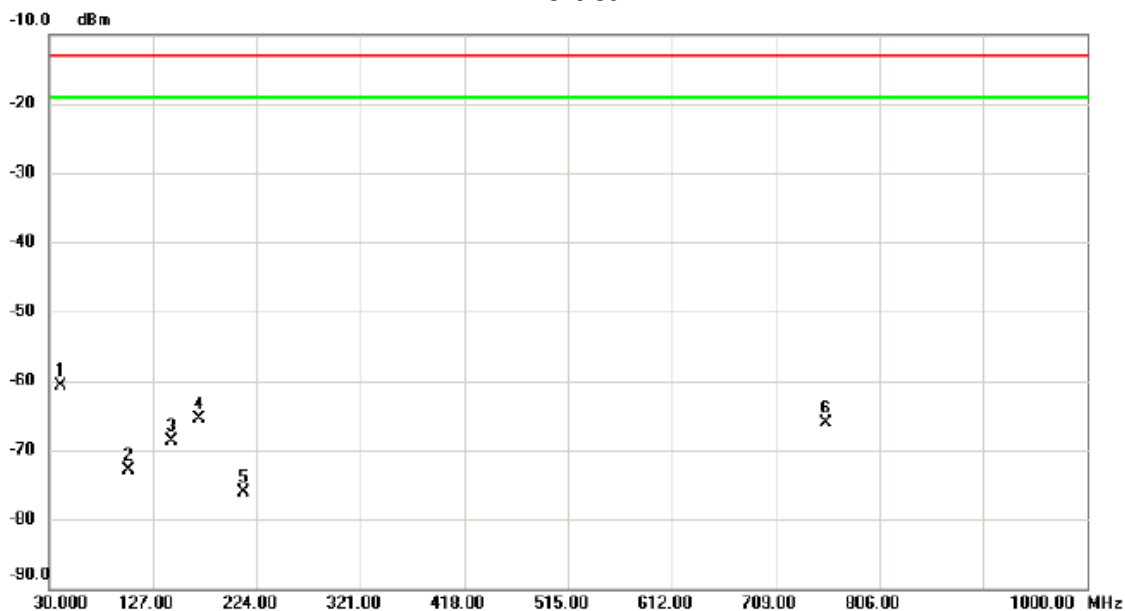

No. Mk.	Freq. MHz	Reading Level dBm	Correct Factor dB	Measurement dBm	Limit dBm	Margin dB	Detector	Comment
1 *	40.6700	-62.79	2.10	-60.69	-13.00	-47.69	peak	
2	103.7200	-71.57	-1.24	-72.81	-13.00	-59.81	peak	
3	144.4600	-71.39	2.60	-68.79	-13.00	-55.79	peak	
4	169.6800	-65.51	-0.01	-65.52	-13.00	-52.52	peak	
5	211.3900	-73.80	-2.34	-76.14	-13.00	-63.14	peak	
6	756.5300	-78.51	12.40	-66.11	-13.00	-53.11	peak	

Test Mode: GSM850_TX CH190_GSM

Horizontal

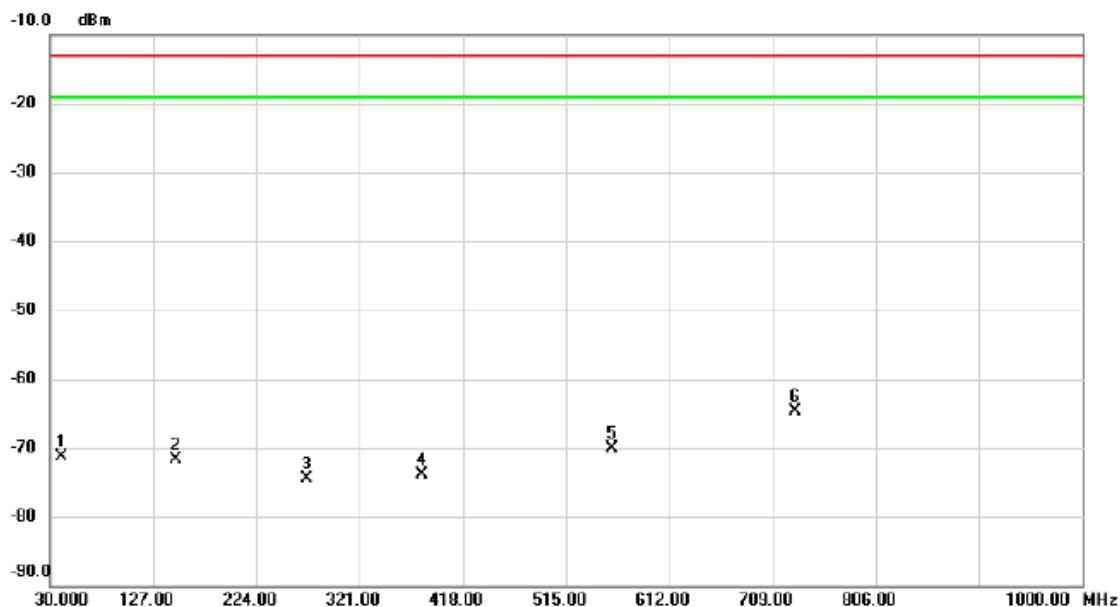

No.	Mk.	Freq. MHz	Reading Level dBm	Correct Factor dB	Measure- ment dBm	Limit dBm	Margin dB	Detector	Comment
1		40.6700	-73.51	2.21	-71.30	-13.00	-58.30	peak	
2		148.3400	-75.82	4.06	-71.76	-13.00	-58.76	peak	
3		271.5300	-77.46	2.94	-74.52	-13.00	-61.52	peak	
4		379.2000	-79.86	6.00	-73.86	-13.00	-60.86	peak	
5		558.6500	-78.29	8.28	-70.01	-13.00	-57.01	peak	
6	*	730.3400	-77.94	13.25	-64.69	-13.00	-51.69	peak	

Test Mode: GSM850_TX CH190_GSM

Vertical

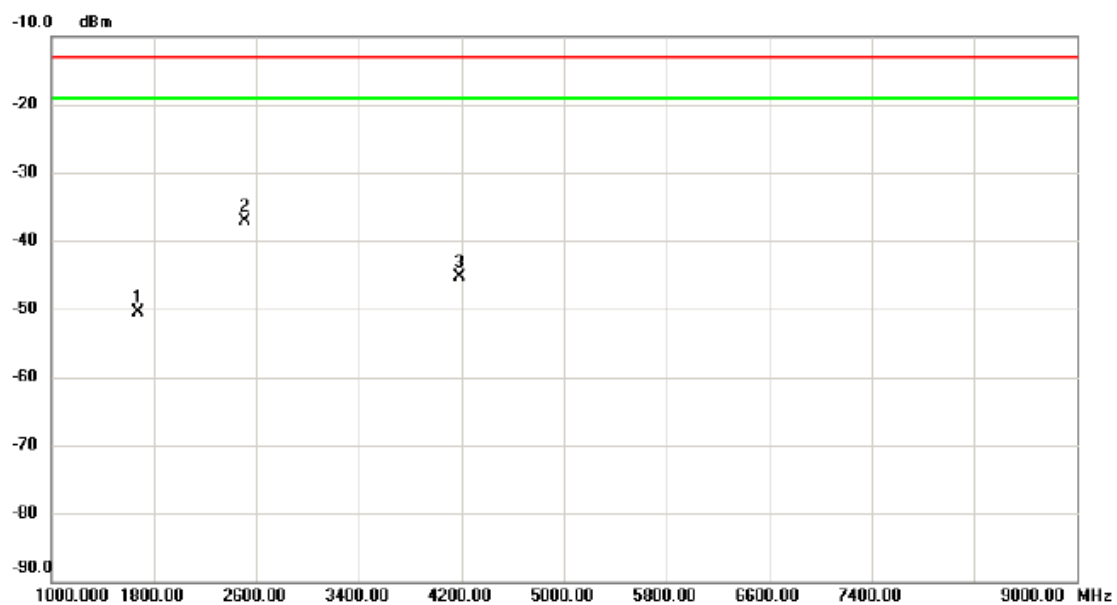

No.	Mk.	Freq. MHz	Reading Level dBm	Correct Factor dB	Measure- ment dBm	Limit dBm	Margin dB	Detector	Comment
1		1672.000	-56.92	6.48	-50.44	-13.00	-37.44	peak	
2	*	2512.000	-49.32	12.21	-37.11	-13.00	-24.11	peak	
3		4184.000	-59.83	14.63	-45.20	-13.00	-32.20	peak	

Test Mode: GSM850_TX CH190_GSM

Horizontal

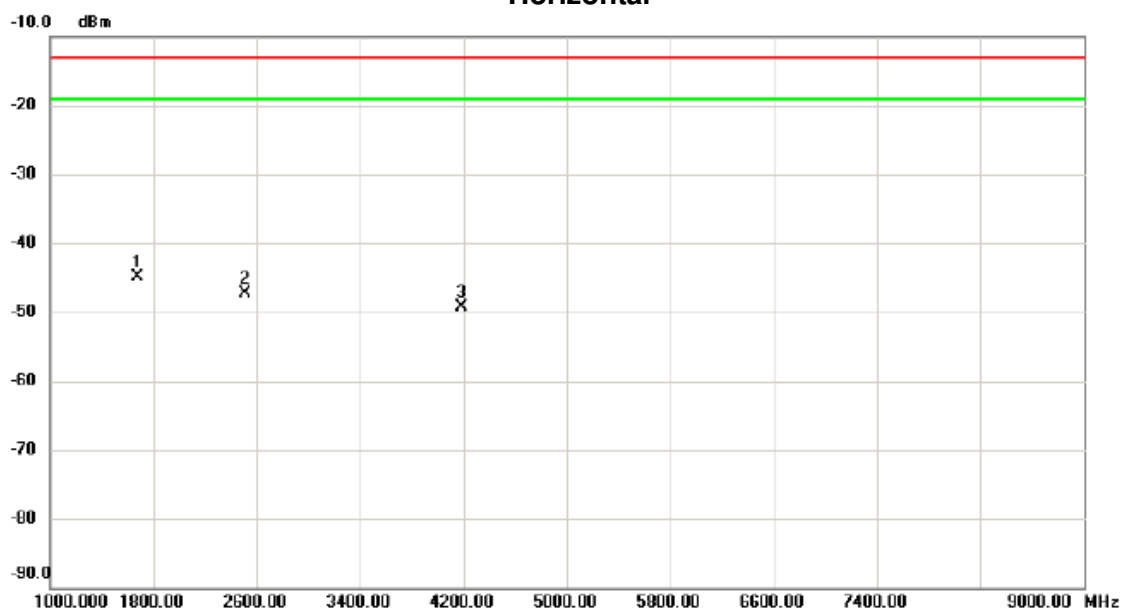

No.	Mk.	Freq. MHz	Reading Level dBm	Correct Factor dB	Measure- ment dBm	Limit dBm	Margin dB	Detector	Comment
1	*	1672.000	-53.00	8.16	-44.84	-13.00	-31.84	peak	
2		2512.000	-52.55	5.29	-47.26	-13.00	-34.26	peak	
3		4184.000	-61.67	12.40	-49.27	-13.00	-36.27	peak	

Test Mode: GSM850_TX CH190_EDGE

Vertical

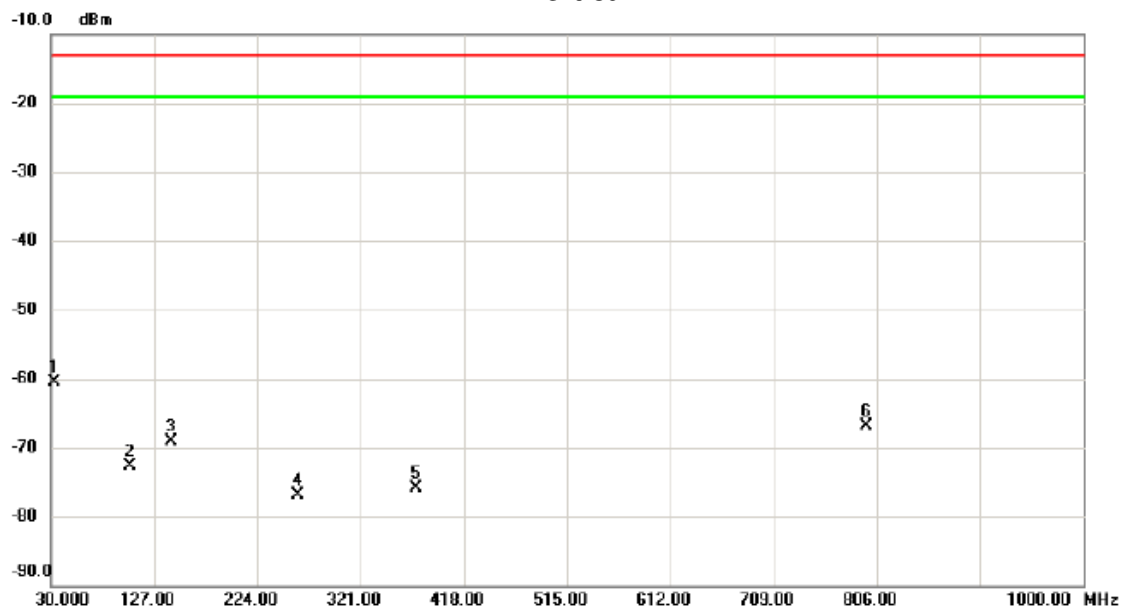

No.	Mk.	Freq. MHz	Reading Level dBm	Correct Factor dB	Measure- ment dBm	Limit dBm	Margin dB	Detector	Comment
1	*	32.9100	-59.54	-0.96	-60.50	-13.00	-47.50	peak	
2		104.6900	-71.47	-1.20	-72.67	-13.00	-59.67	peak	
3		143.4900	-71.61	2.50	-69.11	-13.00	-56.11	peak	
4		261.8300	-77.90	1.01	-76.89	-13.00	-63.89	peak	
5		373.3800	-79.44	3.50	-75.94	-13.00	-62.94	peak	
6		796.3000	-78.85	11.92	-66.93	-13.00	-53.93	peak	

Test Mode: GSM850_TX CH190_EDGE

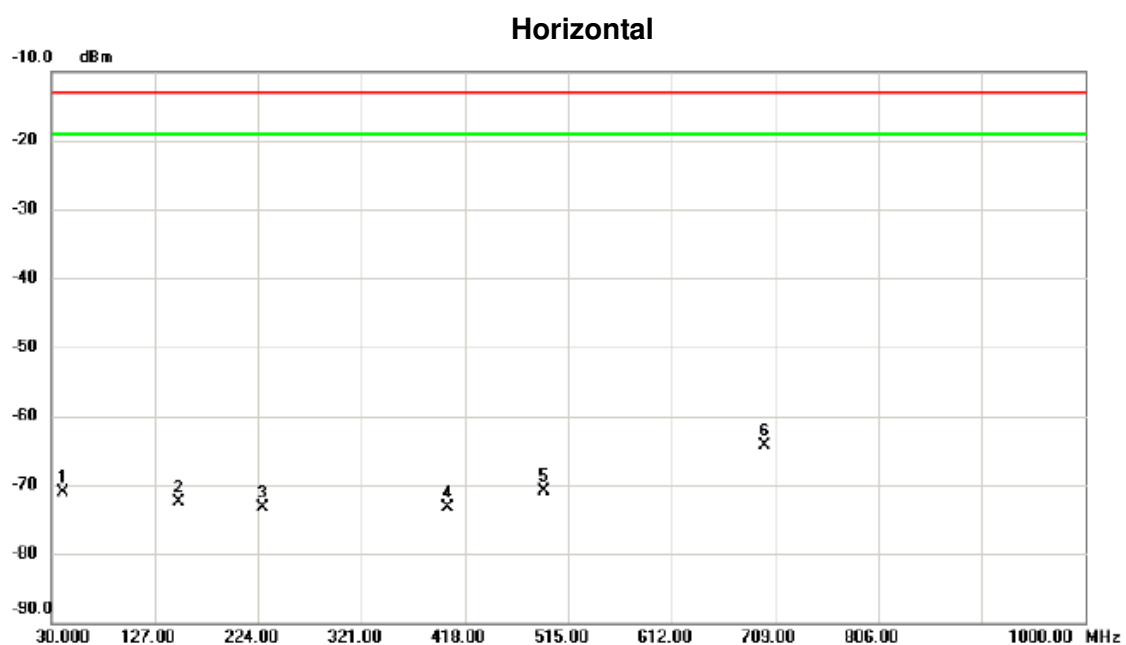

No.	Mk.	Freq. MHz	Reading Level dBm	Correct Factor dB	Measure- ment dBm	Limit dBm	Margin dB	Detector	Comment
1		40.6700	-73.32	2.21	-71.11	-13.00	-58.11	peak	
2		149.3100	-76.63	4.16	-72.47	-13.00	-59.47	peak	
3		228.8500	-76.15	2.94	-73.21	-13.00	-60.21	peak	
4		401.5100	-79.18	5.96	-73.22	-13.00	-60.22	peak	
5		492.6900	-78.46	7.53	-70.93	-13.00	-57.93	peak	
6	*	699.3000	-78.16	13.93	-64.23	-13.00	-51.23	peak	

Test Mode: GSM850_TX CH190_EDGE

Vertical

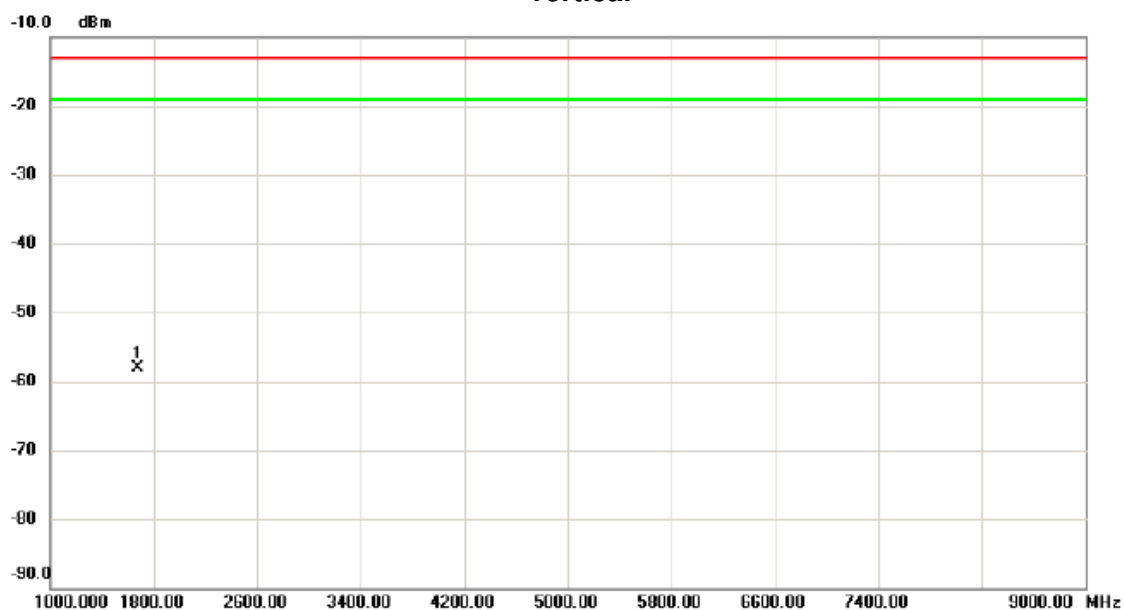

No.	Mk.	Freq. MHz	Reading Level dBm	Correct Factor dB	Measure- ment dBm	Limit dBm	Margin dB	Detector	Comment
1	*	1673.200	-64.50	6.50	-58.00	-13.00	-45.00	peak	

Test Mode: GSM850_TX CH190_EDGE

Horizontal

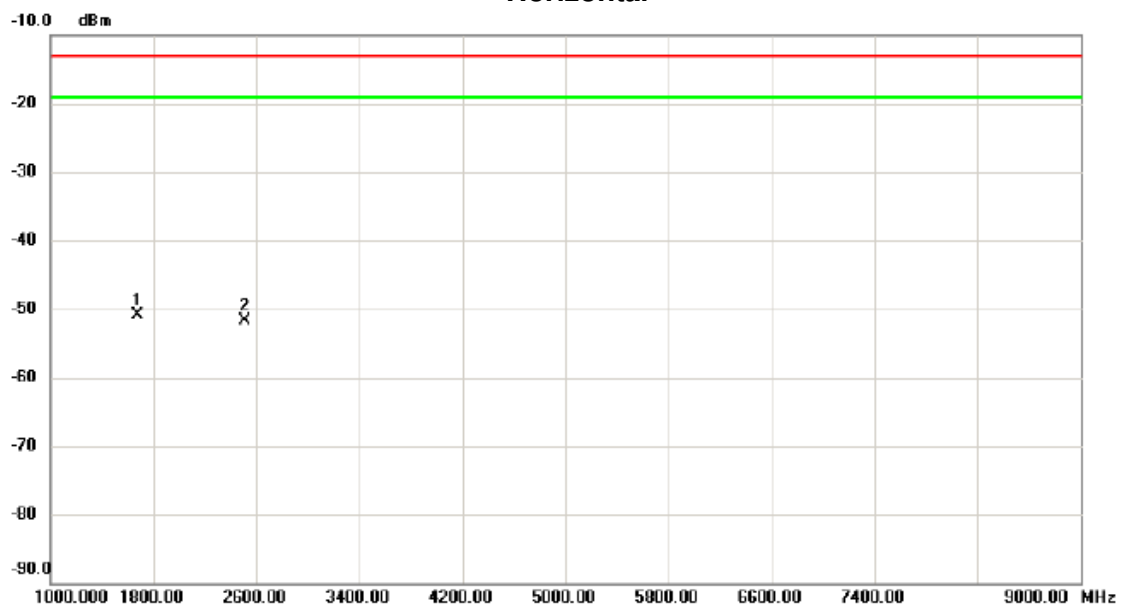

No.	Mk.	Freq. MHz	Reading Level dBm	Correct Factor dB	Measure- ment dBm	Limit dBm	Margin dB	Detector	Comment
1	*	1672.000	-59.04	8.16	-50.88	-13.00	-37.88	peak	
2		2512.000	-57.08	5.29	-51.79	-13.00	-38.79	peak	

Test Mode: WCDMA Band V_TX CH4182

Vertical

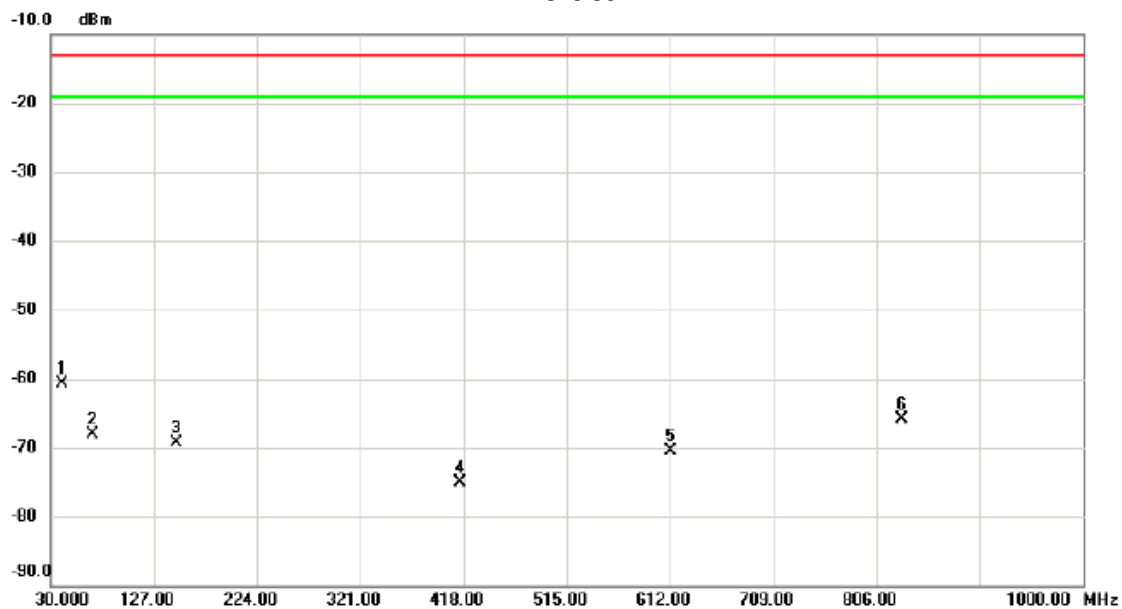

No.	Mk.	Freq. MHz	Reading Level dBm	Correct Factor dB	Measure- ment dBm	Limit dBm	Margin dB	Detector	Comment
1	*	40.6700	-62.84	2.10	-60.74	-13.00	-47.74	peak	
2		69.7700	-68.09	-0.08	-68.17	-13.00	-55.17	peak	
3		148.3400	-72.18	2.98	-69.20	-13.00	-56.20	peak	
4		415.0900	-79.70	4.52	-75.18	-13.00	-62.18	peak	
5		612.9700	-79.51	9.07	-70.44	-13.00	-57.44	peak	
6		830.2500	-79.38	13.45	-65.93	-13.00	-52.93	peak	

Test Mode: WCDMA Band V_TX CH4182

Horizontal

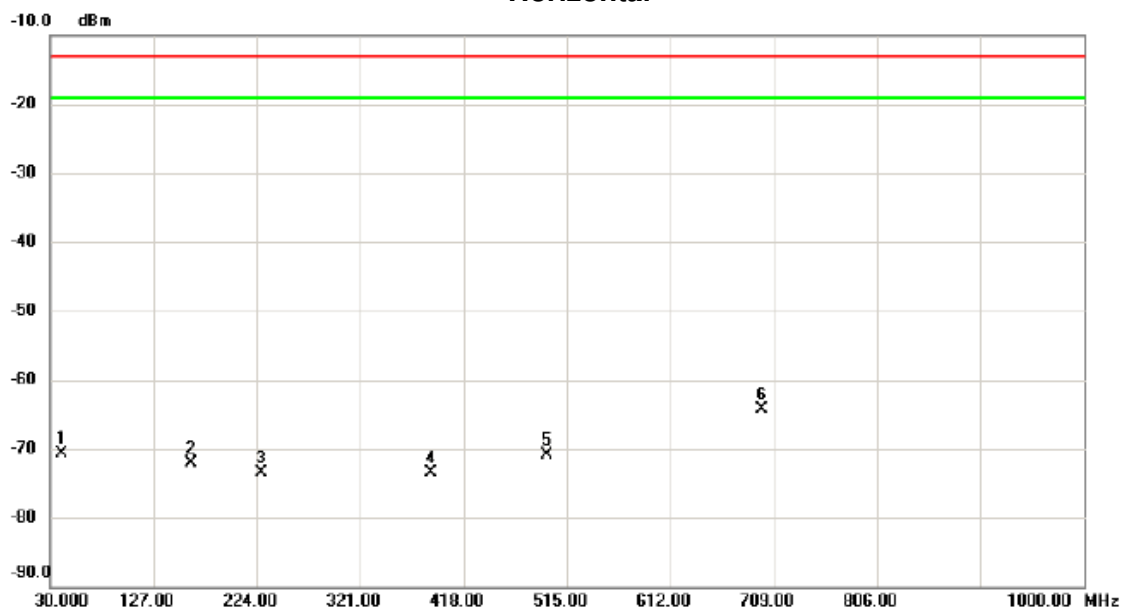

No.	Mk.	Freq. MHz	Reading Level dBm	Correct Factor dB	Measure- ment dBm	Limit dBm	Margin dB	Detector	Comment
1		40.6700	-73.01	2.21	-70.80	-13.00	-57.80	peak	
2		161.9200	-73.99	1.95	-72.04	-13.00	-59.04	peak	
3		228.8500	-76.54	2.94	-73.60	-13.00	-60.60	peak	
4		387.9300	-79.48	6.01	-73.47	-13.00	-60.47	peak	
5		496.5700	-78.80	7.81	-70.99	-13.00	-57.99	peak	
6	*	698.3300	-78.25	13.87	-64.38	-13.00	-51.38	peak	

Test Mode: WCDMA Band V_TX CH4182

Vertical

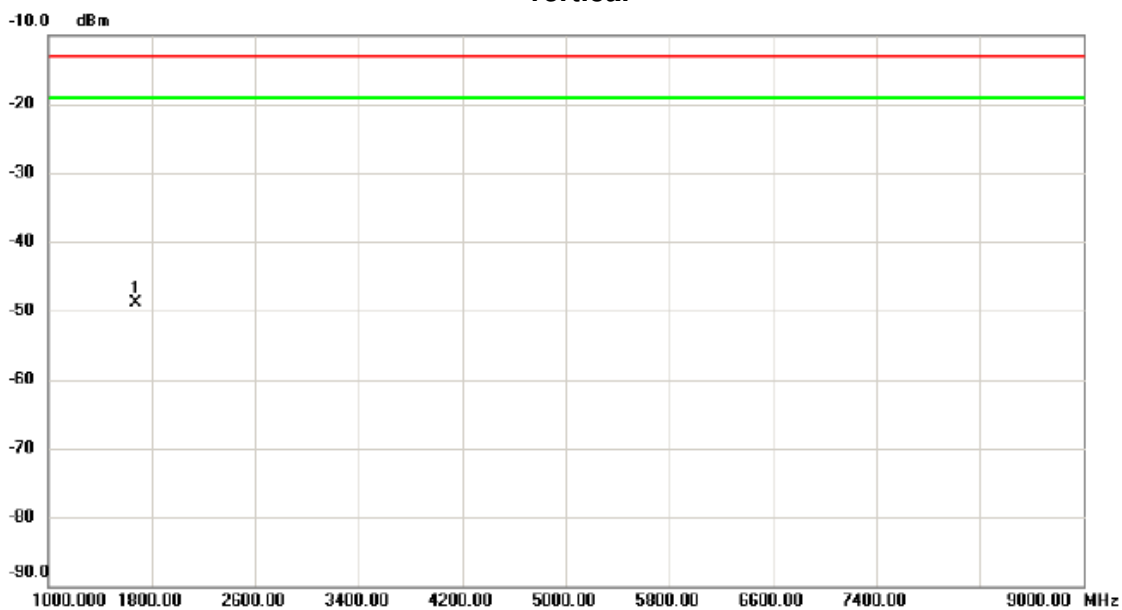

No.	Mk.	Freq. MHz	Reading Level dBm	Correct Factor dB	Measure- ment dBm	Limit dBm	Margin dB	Detector	Comment
1	*	1672.000	-55.35	6.48	-48.87	-13.00	-35.87	peak	

Test Mode: WCDMA Band V_TX CH4182

Horizontal

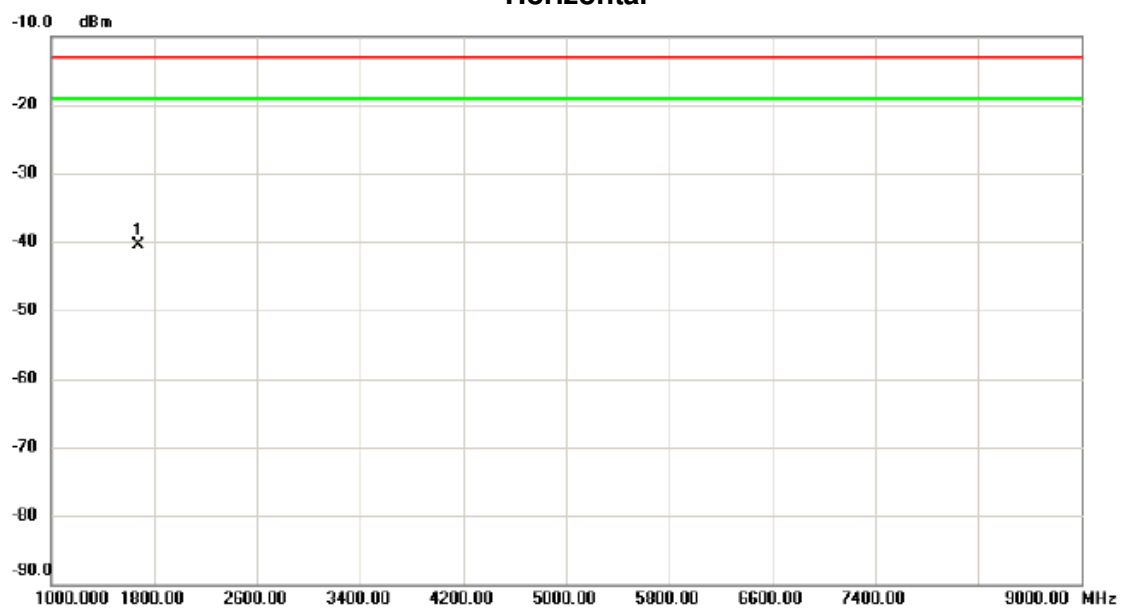

No.	Mk.	Freq. MHz	Reading Level dBm	Correct Factor dB	Measure- ment dBm	Limit dBm	Margin dB	Detector	Comment
1	*	1672.000	-48.72	8.16	-40.56	-13.00	-27.56	peak	

ATTACHMENT E - BAND EDGE

GSM850

GSM

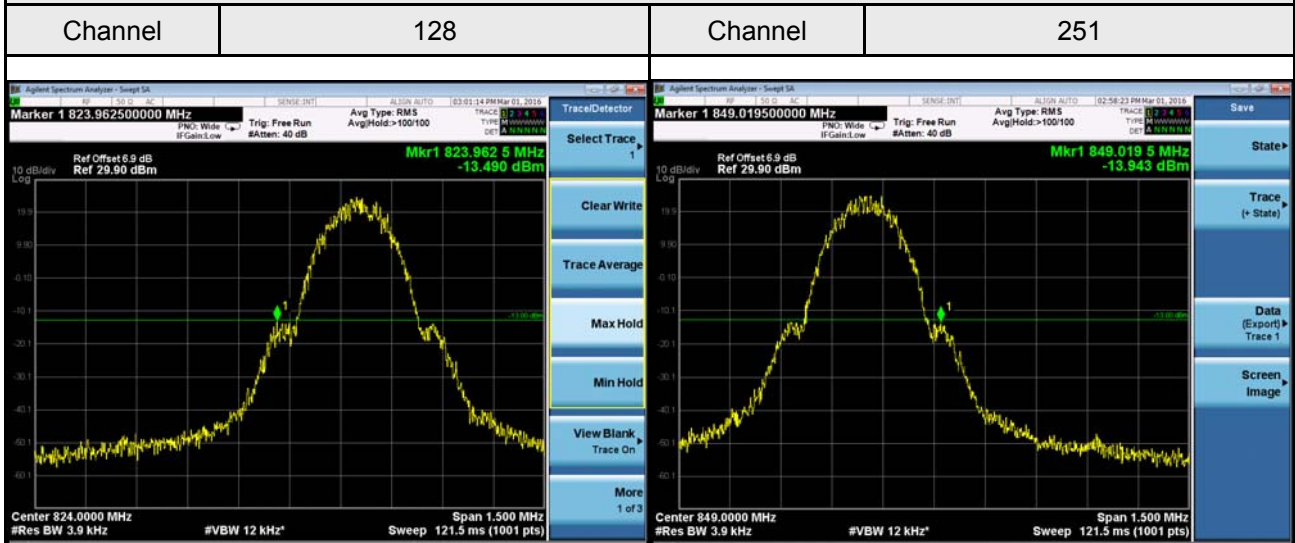

EDGE

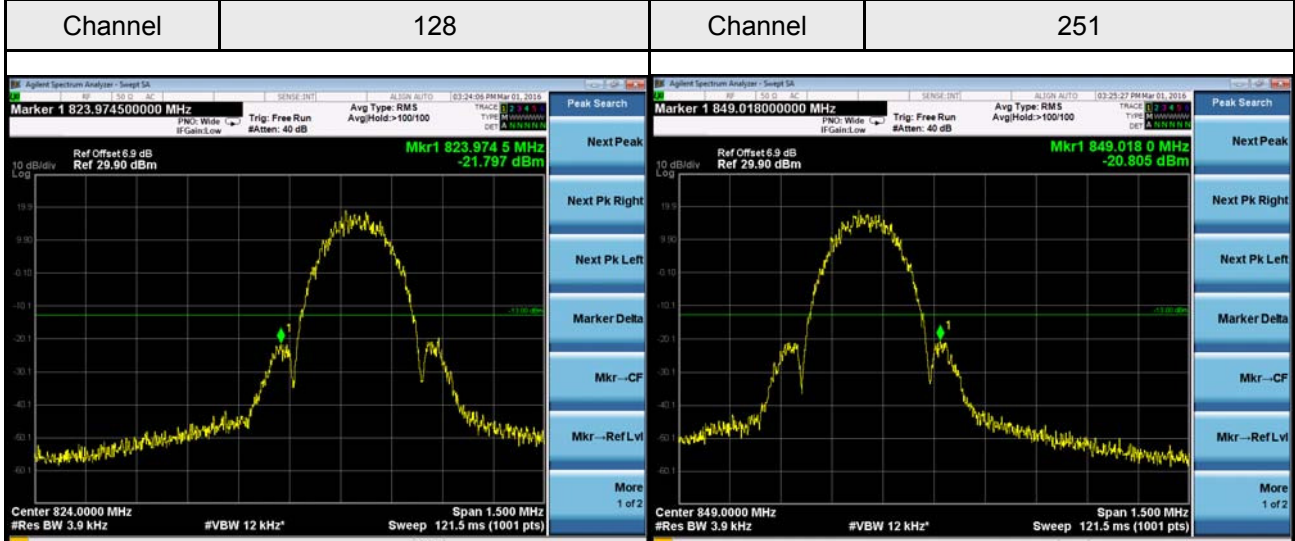

WCDMA Band V

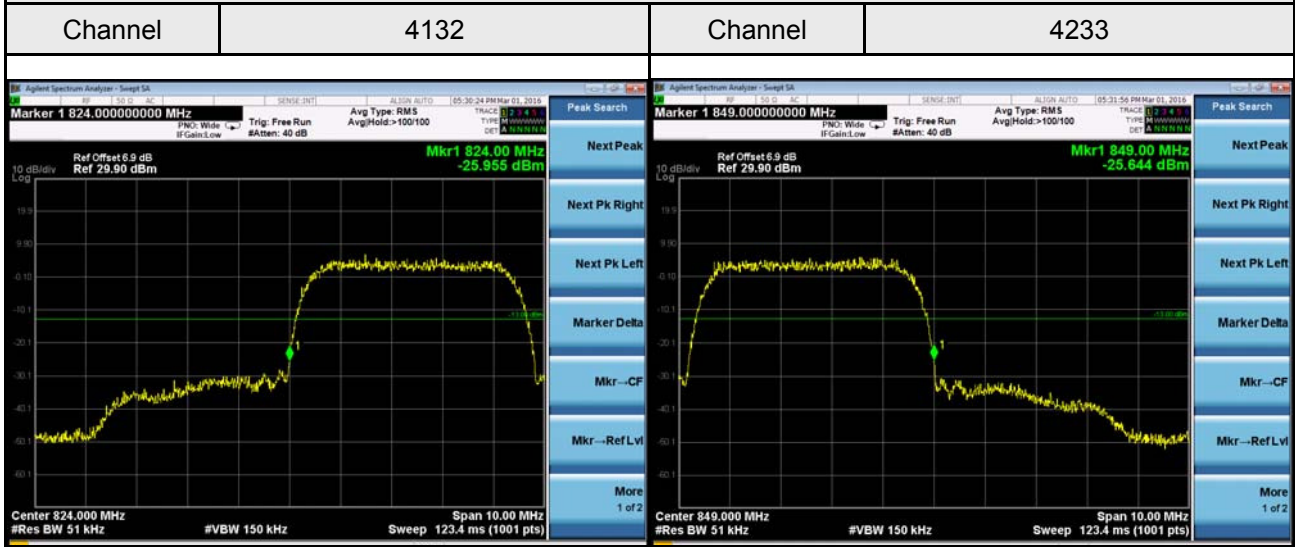

ATTACHMENT F – PEAK TO AVERAGE RATIO

GSM 850 Spectrum Plot



WCDMA Band V Spectrum Plot

4132

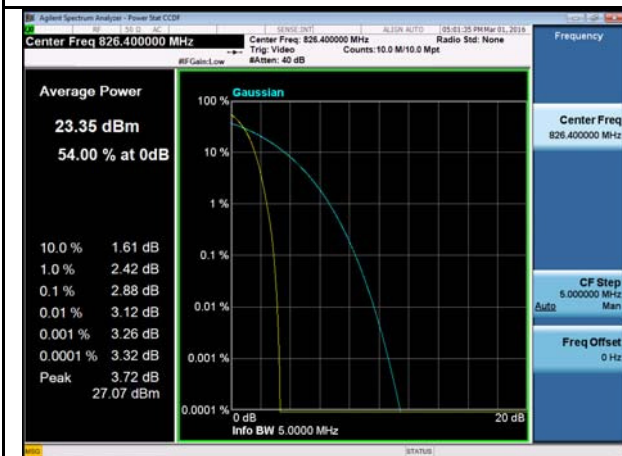

4182

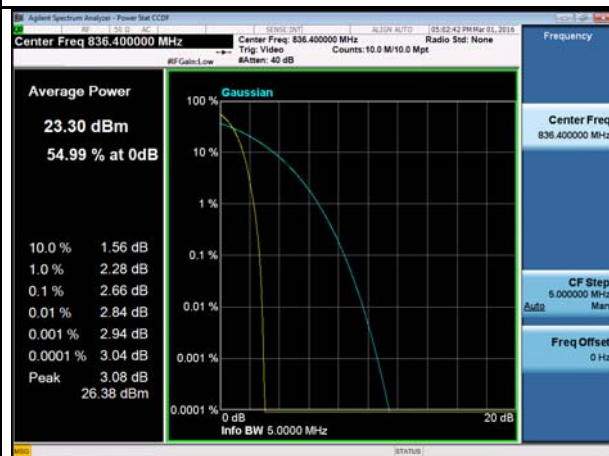

4233

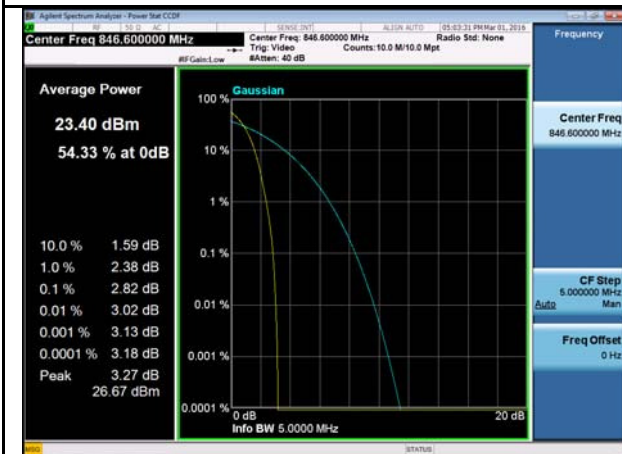

-

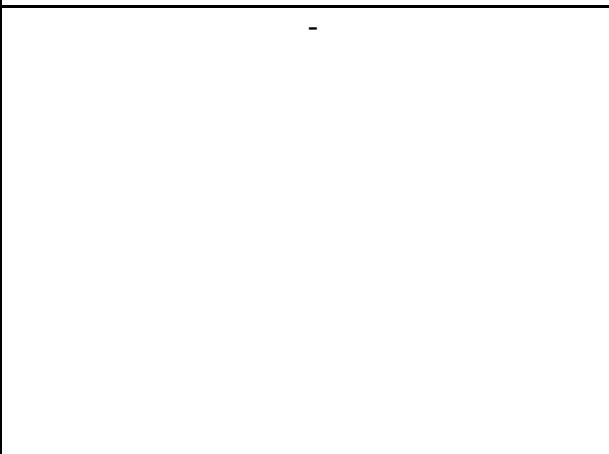

ATTACHMENT G - FREQUENCY STABILITY

Test Mode:	GSM850_CH190
------------	--------------

Temperature vs. Frequency Stability

Temperature(°C)	Frequency Error (Hz)	Frequency Error (ppm)	Limit(ppm)
-30	7.52	0.009123999	2.5
-20	1.64	0.001989808	2.5
-10	8.41	0.010203834	2.5
0	4.93	0.005981558	2.5
10	6.32	0.007668042	2.5
20	4.75	0.005763164	2.5
30	9.84	0.01193885	2.5
40	9.16	0.011113807	2.5
50	4.02	0.004877457	2.5
Max. Deviation (ppm)	9.84	0.01193885	2.5

Voltage vs. Frequency Stability

Voltage(Volts)	Frequency Error (Hz)	Frequency Error (ppm)	Limit(ppm)
3.8	6.91	0.008383887	2.5
3.5	5.82	0.007061393	2.5
4.35	4.16	0.005047319	2.5
Max. Deviation (ppm)	6.91	0.008383887	2.5

Test Mode:	WCDMA Band V_CH4182
------------	---------------------

Temperature vs. Frequency Stability

Temperature(°C)	Frequency Error (Hz)	Frequency Error (ppm)	Limit(ppm)
-30	8.21	0.009815878	2.5
-20	2.45	0.00292922	2.5
-10	5.43	0.006492109	2.5
0	5.27	0.006300813	2.5
10	6.71	0.008022477	2.5
20	6.68	0.007986609	2.5
30	3.68	0.004399809	2.5
40	7.53	0.009002869	2.5
50	8.35	0.009983262	2.5
Max. Deviation (ppm)	8.35	0.009983262	2.5

Voltage vs. Frequency Stability

Voltage(Volts)	Frequency Error (Hz)	Frequency Error (ppm)	Limit(ppm)
3.8	8.24	0.009851746	2.5
3.5	6.64	0.007938785	2.5
4.35	7.85	0.009385462	2.5
Max. Deviation (ppm)	8.24	0.009851746	2.5