



東莞市可陽欣電子有限公司



SPECIFICATION FOR APPROVAL

CUSTOMER: _____

PRODUCT NAME: _____

CUSTOMER NO: **SEL-UWAY-10TS-007**

PART NO.: **KYX-A11L10**

ISSUE NO.: **A**

DATE: **18/Jul/23**

MARK	REVISED CONTENT	APPROVED DATE
		

PREPARED	CHECKED	APPROVED
<i>Su shi hong</i>	<i>Angel Liu</i>	<i>Dong Wu</i>

CUSTOMER CONFIRM
R&D:
QA:

Manufacturer: Dongguan Keyangxin Electronics Co., LTD
Add: No. 6, No. 1, Fulong Industrial Road, Shipai Town, Dongguan City, Guangdong Province

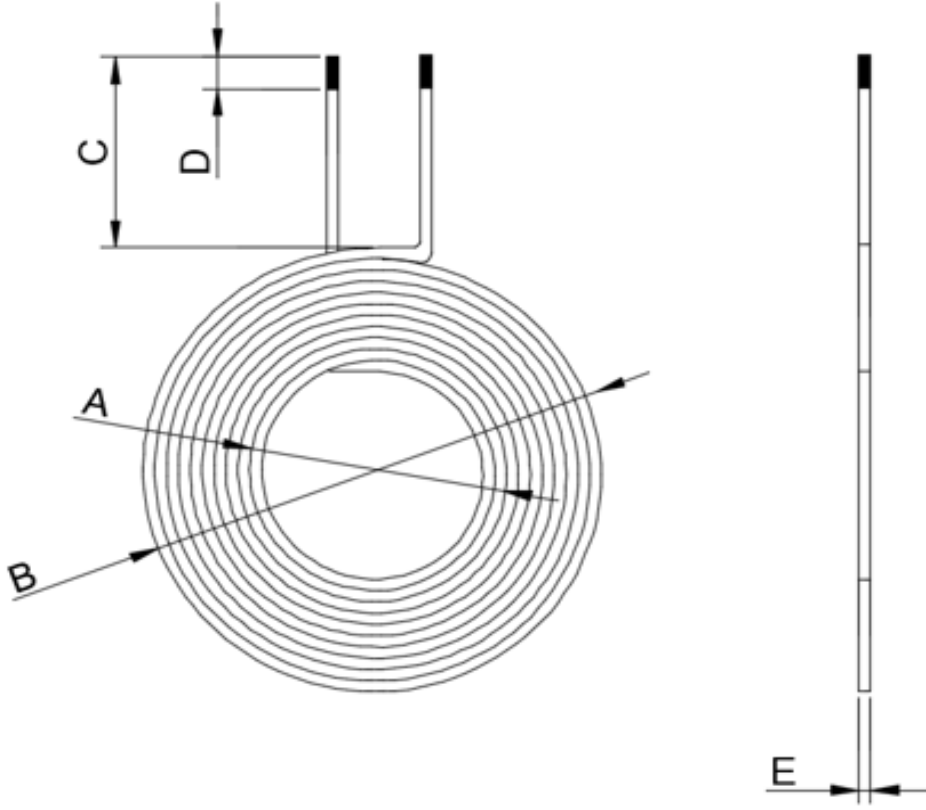

Schematic&Construction

1. Machine Dimension:(Unit:mm)

	A	20.5±0.5 mm
	B	43±1 mm
	C	10±2mm
	D	3±1mm
	E	1.2±0.1 mm

注：E 尺寸只是线圈的厚度不含内引线尺寸

NOTE:The E size is only the thickness of the coil and does not include the inner lead size

CUSTOMER		CUSTOMER NO:	SEL-UWAY-10TS-007	ISSUE NO.	A
REVISE NO	A	DATE	2023/7/18	PAGE	2 OF 3
 東莞市可陽欣電子有限公司		PREPARED	CHECKED	APPROVED	
		<i>Su shi hong</i>	<i>Angel Liu</i>	<i>Dong Wu</i>	

Schematic&Construction

2.Winding And Operation Sequence:

ITEM	START	FINISH	MATERIAL	TURNS	TAPE	DESCRIPTION
1	S	F	0.08*105P	10Ts	/	



3.ELECTRICAL CHARACTERISTICS:

1). Indu Test: @100KHZ,1.0V.

(S-F) 3.8UH±10%

2). DCR Test:

(S-F) 45mΩ Max

CUSTOMER		CUSTOMER NO:	SEL-UWAY-10TS-007	ISSUE NO.	A
REVISE NO	A	DATE	2023/7/18	PAGE	3 OF 3
 東莞市可陽欣電子有限公司		PREPARED	CHECKED	APPROVED	
		<i>Su shi hong</i>	<i>Angel Liu</i>	<i>Dong Wu</i>	