

东莞市金赞智能科技有限公司

DONGGUAN KIMCHEN INDUSTRY INTL LIMITED



东莞市金赞智能科技有限公司

产品规格书

PRODUCT SPECIFICATION

客 户:	_____
CUSTOMER:	_____
客户料号:	_____
CUST P/N:	_____
金赞料号:	_____
K C P/N:	_____
产品型号:	苹果手表线圈 (带磁铁 8.1uH)-线圈长 13mm (14*21*0.08*24P*14TS*13MM)
D E S E :	_____
日 期:	2023. 7. 27
D A T E :	_____
版 本:	A. 1
VERSION :	_____

(客户承认受领印) ACCEPTANCE STAMP

拟制 PREPARED BY	跟单员 MERCHANDISER	工程审核 ENGINEER CHECKED BY	制程审核 PRODUCTION CHECKDED BY	批准 APPROVED BY
王云帆				

Address: 东莞市石碣镇西沙路 2 号 Tel: 86-076986018114 Fax: 86-076986015646

Http://www.jzcoil.com

文件编号 FilNo: KC-JZ-09-008

东莞市金赞智能科技有限公司

DONGGUAN KIMCHEN INDUSTRY INTL LIMITED

版本变更履历
Version Change History客户料号:
CUST P/N

109.020

金赞型号:
KC DESE

14*20.5*0.08*24P*14TS*13MM

版本 Rev.	变更前 Before Change	变更后内容 DESCRIPTION (Content Or Reason For Changed)	日期 Date	修订者 Revisor
A.0	--	新发行 (Initial Release)	2023/4/1	王云帆
A.1	引线长度 8+2/-0	变更成 13+2/-0	2023/7/27	王云帆

1. 产品外形尺寸 (OVERALL DIMENSIONS OF PRODUCTS):

拟制
PREPARED BY

王云帆

工程审核
ENGINEER CHECKED BY

胡志军

制程审核
PRODUCTION CHECKED BY

王云帆

Address: 东莞市石碣镇西沙路 2 号 Tel: 86-076986018114

Fax: 86-076986015646

Http://www.jzcoil.com

文件编号 FileNo: KC-JZ-09-008

东莞市金赞智能科技有限公司

DONGGUAN KIMCHEN INDUSTRY INTL LIMITED

规格内容
Specification

客户料号: CUST P/N	109.020
金赞型号: KC DESE	14*20.5*0.08*24P*14TS*13MM

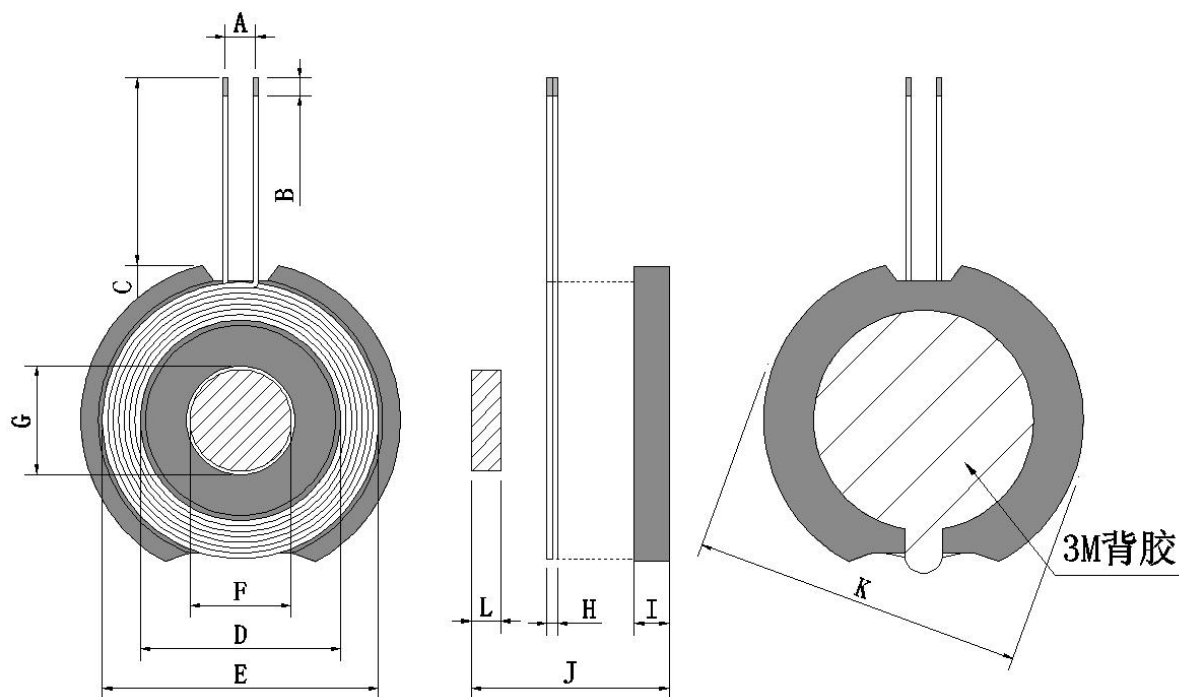

单位(Unit):毫米(mm)

A	B	C	D	E	F	G
2±1	1-2	13+2/-0	14±0.5	21MAX	7.5MAX	7.8±0.5
H	I	J	K	L		
1.05±0.05	2.5±0.2	2.85MAX	25±1	2.2±0.1		

PS:1. C 为磁外引线长度; 2. H 不含进线; 3. 线圈反贴; 4. J 不含离型纸

圈数 Turns	线径 Wire Dia.	绕线方式 疏/密 Wdg. Type Spred/Close	绕线方向 Wdg. Direction	相交 是/否 Intersect Yes/Not	线圈 正/反贴 Coil Positive/Anti Paste
14TS	0.08*24P 热风绞线 (Hot Air stranded Wire)	密绕 (Close)	逆时针 (Anticlockwise)	是 (Yes)	反贴 (Anti-Paste)

拟制 PREPARED BY	工程审核 ENGINEER CHECKED BY	制程审核 PRODUCTION CHECKED BY
王云帆	胡志军	高海华
Address: 东莞市石碣镇西沙路 2 号	Tel: 86-076986018114	Fax: 86-076986015646

Http://www.jzcoil.com

文件编号 FilNo: KC-JZ-09-008

东莞市金赞智能科技有限公司

DONGGUAN KIMCHEN INDUSTRY INTL LIMITED

规格内容
Specification

客户料号: CUST P/N	109.020
金赞型号: KC DESE	14*20.5*0.08*24P*14TS*13MM

所有材料要求合格 ROHS 标准

2. 电气特性 (ELECTRICAL CHARACTERISTICS):

温度 TEMPERATURE: 25 ± 10°C, 湿度 RELATIVE HUMIDITY: 65 ± 10%

序号 NO.	项目 ITEM	端子 TERMINAL	标准 SPECIFICATION	测试条件 TEST FREQUENCY	测试仪器 TEST EQUIPMENTS
1	IND	S-F	线圈: 4.9 uH ± 10%	1kHz/V	LCZ METER 1062
1	IND	S-F	线圈加磁片: 8.1 uH ± 10%	1kHz/V	LCZ METER 1062

3. 材料清单 (BILL OF MATERIALS):

材料名称 Material name	品名描述 Description	物料代码 Material Code	厂商代码 Vendor code
线材	0.08*24P 热风绞线	JX-2U-F-0009	ZY
软磁片	G25 ± 1*7.8*2.5 ± 0.2H (有孔有槽) (小槽: 5.2*2.0H 大槽 8.5*2.0H) 磁片表面无 Logo	GCP-T-00206	QT
3M 背胶(灰色)	15*0.15H (无孔带耳朵) 离型纸白底蓝字	SMJ-3M-00061	MLS
锡条	环保无铅焊锡条	无铅高温锡条	XC
强磁铁 N48	7.5*2.2H (2800-3200GS)	CT-T-0008	YY

拟制
PREPARED BY

王云帆

工程审核
ENGINEER CHECKED BY

胡志军

制程审核
PRODUCTION CHECKED BY

王云帆

Address: 东莞市石碣镇西沙路 2 号 Tel: 86-076986018114

Fax: 86-076986015646

Http://www.jzcoil.com

文件编号 FilNo: KC-JZ-09-008