

东莞市金赞智能科技有限公司

DONGGUAN KIMCHEN INDUSTRY INTL LIMITED



DONGGUAN KIMCHEN INDUSTRY INTL LIMITED

SPECIFICATION FOR APPROVAL

Shenzhen Powerqi Technology Co., Ltd

CUSTOMER: _____

3-122DX01010AA-100

CUST P/N: _____

J30-000204-001

K C P/N: _____

20.5*39*0.08*80P*11TS*20MM

D E S E : _____

5th June 204

D A T E : _____

A. 0

VERSION : _____

ACCEPTANCE STAMP

PREPARED BY	MERCHANDISER	ENGINEER CHECKED BY	APPROVED BY
Huilin Yan			

Address: No2 Xisha Road Shijie Guangdong 523290 Guangdong China

File No: KC-JZ-09-009

东莞市金赞智能科技有限公司

DONGGUAN KIMCHEN INDUSTRY INTL LIMITED

			CUST P/N	3-122DX01010AA-100
Specification			Des. ,	20.5*39*0.08*80P*11TS*20

1. OVERALL DIMENSIONS OF PRODUCTS):

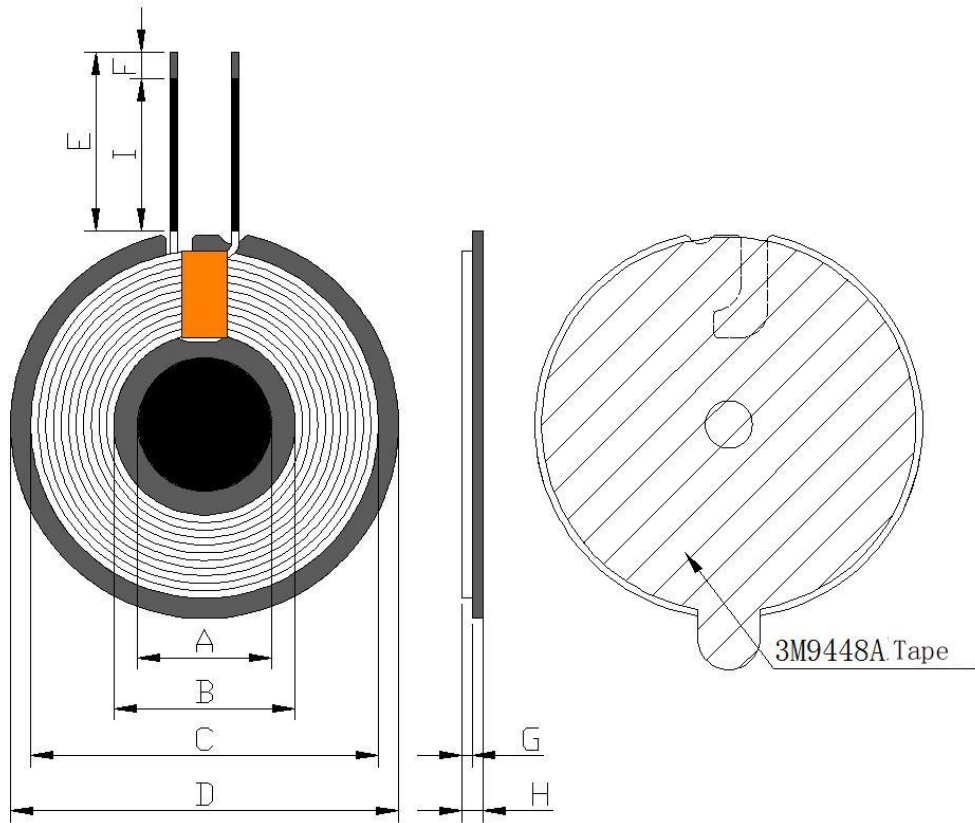

A	B	C	D	E	F	G	H	I
15±0.5	20.5±0.5	39±0.5	43.5±0.5	20±1	3±1	0.95±0.05	2.3MAX	17±1

Remark: H as total thickness , release paper excluded.

Turns	Wire Diameter	Winding Direction	Lead wire Intersect Yes/Not	Coil front/reverse Paste
11	0.08*80 Strand Litz Wire	CCW	YES	reverse Paste

PREPARED BY	ENGINEER CHECKED BY
Huilin Yan	JIn Li

Address: No2 Xisha Road Shijie Guangdong 523290 Guangdong China

FileNo: KC-JZ-09-009

东莞市金赞智能科技有限公司

DONGGUAN KIMCHEN INDUSTRY INTL LIMITED

Specification	CUST P/N	3-122DX01010AA-100
	Des. ,	20.5*39*0.08*80P*11TS*20

2. ELECTRICAL CHARACTERISTICS :

TEMPERATURE: 25 ± 10°C, RELATIVE HUMIDITY: 65 ± 10%

NO.	ITEM	TERMINAL	VALUE	TEST FREQUENCY	TEST EQUIPMENTS
1	IND	S-F	Coil+ferrite: 7.7 uH ± 10%	1kHz/V	LCZ METER 1062

3. BILL OF MATERIAIS :

NO.	Material name	Description	Material Code	Vendor Code
1	Copper Wire	0.08*80 Strand Litz Wire	JX-2U-F-0008	CX
2	Ferrite Core	G43.5 ± 0.5*5.3*0.8	GCP-T-00298	HYT
3	Ferrite Core	15*0.7H	GCP-T-00305	LX
4	Double side Tape	3M 9448A 42*0.12H	SMJ-3M-00077	HWD
5	Double side Tape	13*0.08H	SMJ-T-0082	HWD
6	Epoxy Adhesive	JS-E7202	E7202W	HZY
7	Tin	Lead free tin	TIN	XC
8	Kapton Tape	5mm	TAPE-5	JRM
9	Heat shrink tube	Black , Φ1.0*17MM	/	/

PREPARED BY

ENGINEER CHECKED BY

Huilin Yan

Jln Li

Address: No2 Xisha Road Shijie Guangdong 523290 Guangdong China

FileNo: KC-JZ-09-009