

DEWALT®



**Instruction Manual
Guide D'utilisation
Manual de instrucciones**

DCR010

12V/20V Max* Worksite Bluetooth® Speaker

12 V/20 V max* (FR)

12 V/20 V Máx* (SP)

www.DEWALT.com

**If you have questions or comments, contact us.
Pour toute question ou tout commentaire, nous contacter.
Si tiene dudas o comentarios, contáctenos.**

1-800-4-DEWALT

ENGLISH

English (***original instructions***)

1

Français (*traduction de la notice d'instructions originale*)

?

Español (*traducido de las instrucciones originales*)

?

Definitions: Safety Alert Symbols and Words

This instruction manual uses the following safety alert symbols and words to alert you to hazardous situations and your risk of personal injury or property damage.



DANGER: Indicates an imminently hazardous situation which, if not avoided, **will** result in **death or serious injury**.



WARNING: Indicates a potentially hazardous situation which, if not avoided, **could** result in **death or serious injury**.



CAUTION: Indicates a potentially hazardous situation which, if not avoided, **may** result in **minor or moderate injury**.



(Used without word) Indicates a safety related message.

NOTICE: Indicates a practice **not related to personal injury** which, if not avoided, **may** result in **property damage**.

Fig. A

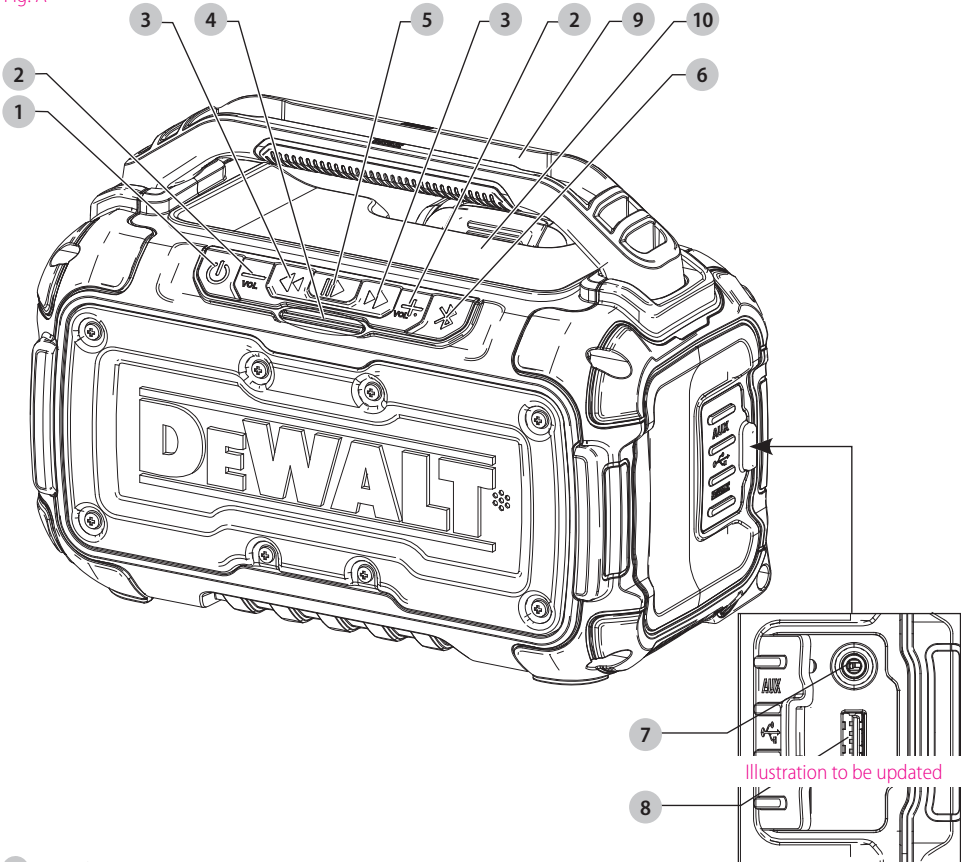

- 1 Power button
- 2 Volume buttons +/-
- 3 Track change buttons
- 4 Bluetooth[®] status indicator
- 5 Play/Pause button
- 6 Bluetooth[®] button
- 7 Auxiliary port
- 8 USB port
- 9 Handle and mobile phone cradle
- 10 Cell phone tray



WARNING: Read all safety warnings and all instructions. Failure to follow the warnings and instructions may result in electric shock, fire and/or serious injury.



WARNING: To reduce the risk of injury, read the instruction manual.

If you have any questions or comments about this or any DEWALT tool, call us toll free at: 1-800-4-DEWALT (1-800-433-9258).

IMPORTANT SAFETY INSTRUCTIONS



WARNING:

- a) Read these instructions.
- b) Keep these instructions.
- c) Heed all warnings.
- d) Follow all instructions.
- e) Do not use this apparatus near water.
- f) Clean only with a dry cloth.
- g) Do not block any ventilation openings. Use in accordance with the manufacturer's instructions.
- h) Do not use near any heat sources such as radiators, heat registers, stoves or other apparatus (including amplifiers) that produce heat.
- i) Do not defeat the safety purpose of the polarized or grounding-type plug. A polarized plug has two blades with one wider than the other. A grounding type plug has two blades and a third grounding prong. The wide blade or the third prong are provided for your safety. If the provided plug does not fit into your outlet, consult an electrician for replacement of the obsolete outlet.
- j) Protect the power cord from being walked on or pinched particularly at plugs, convenience receptacles, and the point where they exit from the apparatus.
- k) Only use attachments/accessories specified by the manufacturer.
- l) Unplug this apparatus during lightning storms or when unused for long periods of time.
- m) Refer all servicing to qualified service personnel. Servicing is required when the apparatus has been damaged in any way, such as power-supply cord or plug is damaged, liquid has been spilled or objects have fallen into the apparatus, the apparatus has been exposed to rain or moisture, does not operate normally, or has been dropped.
- n) Apparatus shall not be exposed to dripping or splashing and no objects filled with liquids, such as vases, shall be placed on the apparatus.
- o) Do not use under wet conditions or in presence of flammable liquids or gases.
- p) Do not keep ears close to this appliance.

Safety Instructions for Speakers

- To reduce the risk of fire or electric shock, do not expose this apparatus to rain or moisture.
- Do not abuse cord. Never carry the speaker by its cord. Never pull the cord to disconnect from the socket. Keep the cord away from heat, oil and sharp edges.
- Remove the battery pack. Switch off before leaving it unattended. Remove the battery pack when not in use, before changing accessories or attachments and before servicing.
- This appliance is not intended for use by persons (including children) with reduced physical, sensory or mental capabilities, or lack of experience and knowledge, unless they have been given supervision or instruction concerning

use of the appliance by a person responsible for their safety.

- Children should be supervised to ensure that they do not play with the appliance.
- No exposed flame sources, such as lighted candles, should be placed on the speaker.
- To reduce the risk of hearing damage, do not place ears too close to the speaker.
- Mains plug is used as the disconnect device; the disconnect device (plug) shall remain readily operable.
- **An extension cord must have adequate wire size (AWG or American Wire Gauge) for safety.** The smaller the gauge number of the wire, the greater the capacity of the cable, that is, 16 gauge has more capacity than 18 gauge. An undersized cord will cause a drop in line voltage resulting in loss of power and overheating. When using more than one extension to make up the total length, be sure each individual extension contains at least the minimum wire size. The following table shows the correct size to use depending on cord length and nameplate ampere rating. If in doubt, use the next heavier gauge. The lower the gauge number, the heavier the cord.

Minimum Gauge for Cord Sets					
Volts	Total Length of Cord in Feet (meters)				
	120 V	25 (7.6)	50 (15.2)	100 (30.5)	150 (45.7)
240 V	50 (15.2)	100 (30.5)	200 (61.0)	300 (91.4)	
Ampere Rating		American Wire Gauge			
More Than	Not More Than				
0	6	18	16	16	14
6	10	18	16	14	12
10	12	16	16	14	12
12	16	14	12	Not Recommended	

The label on this unit may include the following symbols. The symbols and their definitions are as follows:

V	volts	 Class II Construction (double insulated)
Hz	hertz	 no load speed
min	minutes	 rated speed
	or DC..... direct current	 earthing terminal
 Class I Construction (grounded)	 safety alert symbol
... /min.....	per minute	 visible radiation
BPM	beats per minute	 wear respiratory protection
IPM	impacts per minute	 wear eye protection
RPM	revolutions per minute	 wear hearing protection
sfpm	surface feet per minute	 read all documentation
SPM	strokes per minute		
A	amperes		
W	watts		
	or AC..... alternating current		
	or AC/DC... alternating or direct current		

BATTERIES AND CHARGERS

The battery pack is not fully charged out of the carton. Before using the battery pack and charger, read the safety instructions below and then follow charging procedures outlined. When ordering replacement battery packs, be sure to include the catalog number and voltage.

This unit uses a DeWALT charger. Be sure to read all safety instructions before using your charger. Consult the chart at the end of this manual for compatibility of chargers and battery packs.

READ ALL INSTRUCTIONS

Important Safety Instructions for All Battery Packs



WARNING: Read all safety warnings and all instructions for the battery pack, charger and this unit. Failure to follow the warnings and instructions may result in electric shock, fire and/or serious injury.

- Do not charge or use the battery pack in explosive atmospheres, such as in the presence of flammable liquids, gases or dust. Inserting or removing the battery pack from the charger may ignite the dust or fumes.
- NEVER force the battery pack into the charger. DO NOT modify the battery pack in any way to fit into a non-compatible charger as battery pack may rupture causing serious personal injury. Consult the chart at the end of this manual for compatibility of batteries and chargers.
- Charge the battery packs only in designated DeWALT chargers.
- DO NOT splash or immerse in water or other liquids.
- Do not store or use the unit and battery pack in locations where the temperature may reach or exceed 104 °F (40 °C) (such as outside sheds or metal buildings in summer). For best life store battery packs in a cool, dry location.
- Do not incinerate the battery pack even if it is severely damaged or is completely worn out. The battery pack can explode in a fire. Toxic fumes and materials are created when lithium ion battery packs are burned.
- If battery contents come into contact with the skin, immediately wash area with mild soap and water. If battery liquid gets into the eye, rinse water over the open eye for 15 minutes or until irritation ceases. If medical attention is needed, the battery electrolyte is composed of a mixture of liquid organic carbonates and lithium salts.
- Contents of opened battery cells may cause respiratory irritation. Provide fresh air. If symptoms persist, seek medical attention.



WARNING: Burn hazard. Battery liquid may be flammable if exposed to spark or flame.



WARNING: Fire hazard. Never attempt to open the battery pack for any reason. If the battery pack case is cracked or damaged, do not insert into the charger. Do not crush, drop or damage the battery pack. Do

not use a battery pack or charger that has received a sharp blow, been dropped, run over or damaged in any way (e.g., pierced with a nail, hit with a hammer, stepped on). Damaged battery packs should be returned to the service center for recycling.

Transportation



WARNING: Fire hazard. Do not store or carry the battery pack so that metal objects can contact exposed battery terminals. For example, do not place the battery pack in aprons, pockets, tool boxes, product kit boxes, drawers, etc., with loose nails, screws, keys, etc. **Transporting batteries can possibly cause fires if the battery terminals inadvertently come in contact with conductive materials such as keys, coins, hand tools and the like.** The US Department of Transportation Hazardous Material Regulations (HMR) actually prohibit transporting batteries in commerce or on airplanes in carry-on baggage UNLESS they are properly protected from short circuits. So when transporting individual battery packs, make sure that the battery terminals are protected and well insulated from materials that could contact them and cause a short circuit.

NOTE: Lithium-ion batteries should not be put in checked baggage.

Shipping the DeWALT FLEXVOLT™ Battery

The DeWALT FLEXVOLT™ battery has two modes: **Use** and **Shipping**.

Use Mode: When the FLEXVOLT™ battery stands alone or is in a DeWALT 20V Max* product, it will operate as a 20V Max* battery. When the FLEXVOLT™ battery is in a 60V Max* or a 120V Max* (two 60V Max* batteries) product, it will operate as a 60V Max* battery.

Shipping Mode: When the cap is attached to the FLEXVOLT™ battery, the battery is in Shipping Mode.

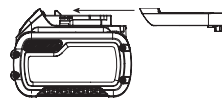

Strings of cells are electrically disconnected within the pack resulting in three batteries with a lower Watt hour (Wh) rating as compared to one battery with a higher Watt hour rating. This increased quantity of three batteries with the lower Watt hour rating can exempt the pack from certain shipping regulations that are imposed upon the higher Watt hour batteries.

The battery label indicates two Watt hour ratings (see example). Depending on how the battery is shipped, the appropriate Watt hour rating must be used to determine the applicable shipping requirements. If utilizing the shipping cap, the pack will be considered 3 batteries at the Watt hour rating indicated for "Shipping". If shipped without the cap or in a tool, the pack will be considered one battery at the Watt hour rating indicated next to "Use".

Example of Use and Shipping Label Marking

USE: 120 Wh Shipping: 3 x 40 Wh

For example, Shipping Wh rating might indicate 3 x 40 Wh, meaning 3 batteries of 40 Watt hours each. The Use Wh rating might indicate 120 Wh (1 battery implied).

ENGLISH

Fuel Gauge Battery Packs (Fig. B)

Some DeWALT battery packs include a fuel gauge which consists of three green LED lights that indicate the level of charge remaining in the battery pack.

The fuel gauge is an indication of approximate levels of charge remaining in the battery pack according to the following indicators:

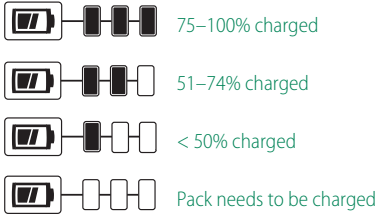

To actuate the fuel gauge, press and hold the fuel gauge button. A combination of the three green LED lights will illuminate designating the level of charge left. When the level of charge in the battery is below the usable limit, the fuel gauge will not illuminate and the battery will need to be recharged.

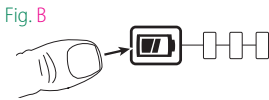

NOTE: The fuel gauge is only an indication of the charge left on the battery pack. It does not indicate tool functionality and is subject to variation based on product components, temperature and end-user application.

For more information regarding fuel gauge battery packs, please call 1-800-4-DeWALT (1-800-433-9258) or visit our website www.dewalt.com.

The RBRC® Seal

The RBRC® (Rechargeable Battery Recycling Corporation) Seal on the nickel cadmium, nickel metal hydride or lithium-ion batteries (or battery packs) indicates that the costs to recycle these batteries (or battery packs) at the end of their useful life have already been paid by DeWALT. In some areas, it is illegal to place spent nickel cadmium, nickel metal hydride or lithium-ion batteries in the trash or municipal solid waste stream and the Call 2 Recycle® program provides an environmentally conscious alternative.

Call 2 Recycle, Inc., in cooperation with DeWALT and other battery users, has established the program in the United States and Canada to facilitate the collection of spent nickel cadmium, nickel metal hydride or lithium-ion batteries. Help protect our environment and conserve natural resources by returning the spent nickel cadmium, nickel metal hydride or lithium-ion batteries to an authorized DeWALT service center or to your local retailer for recycling. You may also contact your local recycling center for information on where to drop off the spent battery. RBRC® is a registered trademark of Call 2 Recycle, Inc.



Important Safety Instructions for All Battery Chargers

⚠ WARNING: Read all safety warnings and all instructions for the battery pack, charger and this unit. Failure to follow the warnings and instructions may result in electric shock, fire and/or serious injury.

- **DO NOT attempt to charge the battery pack with any chargers other than the ones in this manual.** The charger and battery pack are specifically designed to work together.
- **These chargers are not intended for any uses other than charging DeWALT rechargeable batteries.** Any other uses may result in risk of fire, electric shock or electrocution.
- **Do not expose the charger to rain or snow.**
- **Pull by the plug rather than the cord when disconnecting the charger.** This will reduce the risk of damage to the electric plug and cord.
- **Make sure that the cord is located so that it will not be stepped on, tripped over or otherwise subjected to damage or stress.**
- **Do not use an extension cord unless it is absolutely necessary.** Use of improper extension cord could result in risk of fire, electric shock or electrocution.
- **When operating a charger outdoors, always provide a dry location and use an extension cord suitable for outdoor use.** Use of a cord suitable for outdoor use reduces the risk of electric shock.
- **An extension cord must have adequate wire size (AWG or American Wire Gauge) for safety.** The smaller the gauge number of the wire, the greater the capacity of the cable, that is, 16 gauge has more capacity than 18 gauge. An undersized cord will cause a drop in line voltage resulting in loss of power and overheating. When using more than one extension to make up the total length, be sure each individual extension contains at least the minimum wire size. The following table shows the correct size to use depending on cord length and nameplate ampere rating. If in doubt, use the next heavier gauge. The lower the gauge number, the heavier the cord.

Minimum Gauge for Cord Sets

Volts	Total Length of Cord in Feet (meters)				
	120 V	25 (7.6)	50 (15.2)	100 (30.5)	150 (45.7)
240 V	50 (15.2)	100 (30.5)	200 (61.0)	300 (91.4)	
Ampere Rating		American Wire Gauge			
More Than	Not More Than				
0	6	18	16	16	14
6	10	18	16	14	12
10	12	16	16	14	12
12	16	14	12	Not Recommended	

- **Do not place any object on top of the charger or place the charger on a soft surface that might block the ventilation slots and result in excessive internal**

heat. Place the charger in a position away from any heat source. The charger is ventilated through slots in the top and the bottom of the housing.

- **Do not operate the charger with a damaged cord or plug.**
- **Do not operate the charger if it has received a sharp blow, been dropped or otherwise damaged in any way.** Take it to an authorized service center.
- **Do not disassemble the charger; take it to an authorized service center when service or repair is required.** Incorrect reassembly may result in a risk of electric shock, electrocution or fire.
- **Disconnect the charger from the outlet before attempting any cleaning. This will reduce the risk of electric shock.** Removing the battery pack will not reduce this risk.
- **NEVER** attempt to connect 2 chargers together.
- **The charger is designed to operate on standard 120V household electrical power. Do not attempt to use it on any other voltage.** This does not apply to the vehicular charger.

! **WARNING:** Shock hazard. Do not allow any liquid to get inside the charger. Electric shock may result.

! **WARNING:** Burn hazard. Do not submerge the battery pack in any liquid or allow any liquid to enter the battery pack. Never attempt to open the battery pack for any reason. If the plastic housing of the battery pack breaks or cracks, return to a service center for recycling.

! **CAUTION:** Burn hazard. To reduce the risk of injury, charge only DEWALT rechargeable battery packs. Other types of batteries may overheat and burst resulting in personal injury and property damage.

NOTICE: Under certain conditions, with the charger plugged into the power supply, the charger can be shorted by foreign material. Foreign materials of a conductive nature, such as, but not limited to, grinding dust, metal chips, steel wool, aluminum foil or any buildup of metallic particles should be kept away from the charger cavities. Always unplug the charger from the power supply when there is no battery pack in the cavity. Unplug the charger before attempting to clean.

Charging a Battery (Fig. C)

1. Plug the charger into an appropriate outlet before inserting battery pack.

Fig. C

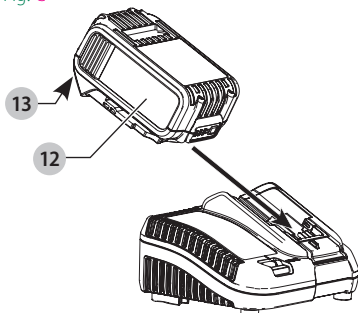

2. Insert the battery pack **12** into the charger, making sure the battery pack is fully seated in the charger. The red (charging) light will blink continuously indicating that the charging process has started.
3. The completion of charge will be indicated by the red light remaining ON continuously. The battery pack is fully charged and may be used at this time or left in the charger. **To remove the battery pack from the charger, push the battery release button **13** on the battery pack and then slide the battery pack out of the charger.**

NOTE: To ensure maximum performance and life of lithium-ion battery packs, charge the battery pack fully before first use.

Charger Operation

Refer to the indicators below for the charge status of the battery pack.

DCB107, DCB112, DCB113, DCB115, DCB118, DCB132		
	Charging	
	Fully Charged	
	Hot/Cold Pack Delay*	

*DCB107, DCB112, DCB113, DCB115, DCB118, DCB132:

The red light will continue to blink, but a yellow indicator light will be illuminated during this operation. Once the battery pack has reached an appropriate temperature, the yellow light will turn off and the charger will resume the charging procedure.

The compatible charger(s) will not charge a faulty battery pack. **The charger will indicate faulty battery pack by refusing to light.**

NOTE: This could also mean a problem with a charger.

If the charger indicates a problem, take the charger and battery pack to be tested at an authorized service center.

Hot/Cold Pack Delay

When the charger detects a battery pack that is too hot or too cold, it automatically starts a Hot/Cold Pack Delay, suspending charging until the battery pack has reached an appropriate temperature. The charger then automatically switches to the pack charging mode. This feature ensures maximum battery pack life.

A cold battery pack will charge at a slower rate than a warm battery pack. The battery pack will charge at that slower rate throughout the entire charging cycle and will not return to maximum charge rate even if the battery pack warms.

The DCB118 charger is equipped with an internal fan designed to cool the battery pack. The fan will turn on automatically when the battery pack needs to be cooled.

Never operate the charger if the fan does not operate properly or if ventilation slots are blocked. Do not permit foreign objects to enter the interior of the charger.

Electronic Protection System

Li-Ion tools are designed with an Electronic Protection System that will protect the battery pack against overloading, overheating or deep discharge.

ENGLISH

The tool will automatically turn off if the Electronic Protection System engages. If this occurs, place the lithium-ion battery pack on the charger until it is fully charged.

Wall Mounting

DCB107, DCB112, DCB113, DCB115, DCB118, DCB132

These chargers are designed to be wall mountable or to sit upright on a table or work surface. If wall mounting, locate the charger within reach of an electrical outlet, and away from a corner or other obstructions which may impede air flow. Use the back of the charger as a template for the location of the mounting screws on the wall. Mount the charger securely using drywall screws (purchased separately) at least 1" (25.4 mm) long, with a screw head diameter of 0.28–0.35" (7–9 mm), screwed into wood to an optimal depth leaving approximately 7/32" (5.5 mm) of the screw exposed. Align the slots on the back of the charger with the exposed screws and fully engage them in the slots.

Charger Cleaning Instructions



WARNING: Shock hazard. Disconnect the charger from the AC outlet before cleaning. Dirt and grease may be removed from the exterior of the charger using a cloth or soft non-metallic brush. Do not use water or any cleaning solutions.

Important Charging Notes

1. Longest life and best performance can be obtained if the battery pack is charged when the air temperature is between 65 °F and 75 °F (18 °–24 °C). DO NOT charge the battery pack below +40 °F (+4.5 °C), or above +104 °F (+40 °C). This is important and will prevent serious damage to the battery pack.
2. The charger and battery pack may become warm to the touch while charging. This is a normal condition, and does not indicate a problem. To facilitate the cooling of the battery pack after use, avoid placing the charger or battery pack in a warm environment such as in a metal shed or an uninsulated trailer.
3. If the battery pack does not charge properly:
 - a. Check operation of receptacle by plugging in a lamp or other appliance;
 - b. Check to see if receptacle is connected to a light switch which turns power off when you turn out the lights;
 - c. Move the charger and battery pack to a location where the surrounding air temperature is approximately 65 °F – 75 °F (18 °– 24 °C);
 - d. If charging problems persist, take the tool, battery pack and charger to your local service center.
4. The battery pack should be recharged when it fails to produce sufficient power on jobs which were easily done previously. DO NOT CONTINUE to use under these conditions. Follow the charging procedure. You may also charge a partially used pack whenever you desire with no adverse effect on the battery pack.
5. Foreign materials of a conductive nature such as, but not limited to, grinding dust, metal chips, steel wool, aluminum foil, or any buildup of metallic particles should be kept away from charger cavities. Always

unplug the charger from the power supply when there is no battery pack in the cavity. Unplug the charger before attempting to clean.

6. Do not freeze or immerse the charger in water or any other liquid.

Storage Recommendations

1. The best storage place is one that is cool and dry, away from direct sunlight and excess heat or cold.
2. For long storage, it is recommended to store a fully charged battery pack in a cool dry place out of the charger for optimal results.

NOTE: Battery packs should not be stored completely depleted of charge. The battery pack will need to be recharged before use.

SAVE THESE INSTRUCTIONS FOR FUTURE USE

COMPONENTS (FIG. A)



WARNING: Never modify the unit or any part of it. Damage or personal injury could result.

Refer to Figure A at the beginning of this manual for a complete list of components.

Intended Use

This DEWALT Bluetooth® speaker is designed to play/stream audio via a wired connection or a wireless Bluetooth® connection to a mobile phone or other audio device.

DO NOT use under wet conditions or in presence of flammable liquids or gases.

DO NOT let children come into contact with the unit. Supervision is required when inexperienced operators use this unit.

USB Port (Fig. A)

The USB port **8** delivers up to 2.1 amps to power devices such as mobile phones, tablets, or portable music players.

When the speaker is powered by the AC cable, the USB port will charge a device without requiring the user to press the power button **1**.

When the speaker is powered by batteries, the USB power output port will charge a device when the user presses the power button **1** to turn the speaker on.

NOTE: The audio device must connect to the speaker via Bluetooth® or the auxiliary port to use the speaker function. The USB port is only a power port for charging the audio device.

Handle/Mobile Phone Cradle (Fig. D)

The speaker should be transported using the handle **9**. The handle has a cradle which can be used to hold the mobile phone while in use.



WARNING: A mobile phone cannot be secured in the cradle and can fall if the speaker is moved or transported. Be sure to remove mobile phone from the cradle before moving or transporting the speaker.

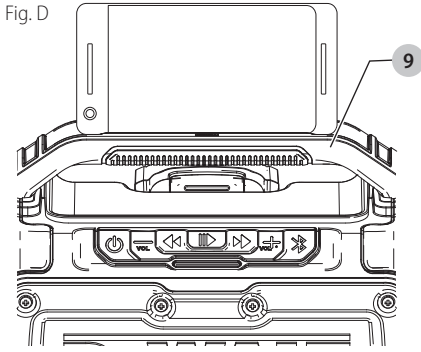

Mobile Phone Tray (Fig. A)

The speaker has a mobile phone tray **10** which can be used to hold the mobile phone while in use.

! WARNING: A mobile phone cannot be secured in the tray and can fall if the speaker is moved or transported. Be sure to remove mobile phone from the tray before transporting the speaker.

Mounting the Speaker (Fig. E)

The speaker is designed to be mountable or to sit upright on a table or work surface. If mounting, use the mounting slots **15** found on the bottom of the speaker as a template for the location of the screws on the wood or wall. Mount the speaker securely using drywall screws (purchased separately) at least 25.4 mm long with a screw head diameter of **5-7 mm**, screwed into wood to an optimal depth leaving approximately 5.5 mm of the screw exposed. Align the slots on the back of the speaker with the exposed screws and fully engage them in the slots. The speaker can be mounted horizontally or vertically in either direction.

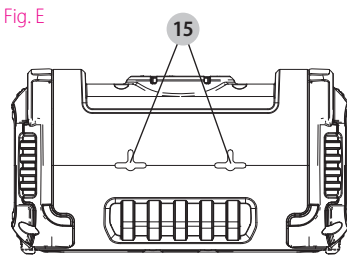

OPERATION

! WARNING: To reduce the risk of serious personal injury, turn unit off and disconnect battery pack before cleaning, making any adjustments or removing/installing attachments or accessories.

The speaker can operate off of DC power (a battery pack) or with the AC power cord supplied.

Powering with the AC Power Cord (Fig. F)

! WARNING: Use only the AC power cord recommended for this product. Use of any other external power supply could damage the speaker or power supply.

To power the speaker using the AC power cord, plug the cord into the speaker's AC power input **11** found on the back of the speaker, then plug the 120V AC cord end into the wall outlet or an appropriate-sized extension cord that is plugged into a wall outlet. Always fully extend the cord before each use.

NOTE: The battery pack must be removed before the AC power cord can be plugged into the AC power input.

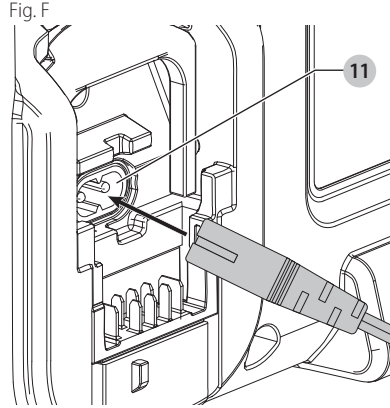

Inserting and Removing the Battery Pack from the Bluetooth® Speaker (Fig. G)

NOTE: Make sure your battery pack **12** is fully charged.

To Install the Battery Pack into the Speaker

1. Align the battery pack **12** with the rails inside the speaker's battery port **14**.
2. Slide it in until the battery pack is firmly seated and ensure that you hear the lock snap into place. Be sure that it does not disengage.

To Remove the Battery Pack from the Speaker

1. Press the battery release button **13** and firmly pull the battery pack out of the battery port.
2. Insert battery pack into the charger as described in the charger section of this manual.

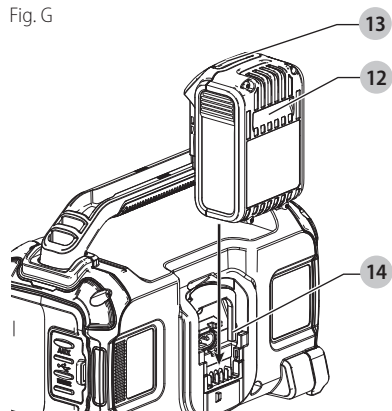

Button Functions (Fig. A)

Power Button

Press the power button ❶ to turn the speaker either on or off.

Play/Pause Button

When audio device connected via Bluetooth®: Press the play/pause button ❷ to begin playing a selection from the audio device. Press the play/pause button again to pause play.

When audio device connected via auxiliary port: Press the play/pause button ❷ to mute the speaker.

Volume Adjustment Buttons

The volume buttons ❸ can be used to increase or decrease volume on the speaker.

NOTE: The play/pause and volume adjustment buttons will function whether it is paired via Bluetooth® or connected via the auxiliary port.

Track Change Buttons

The right and left track change buttons ❹ can be used to skip or go to previous tracks on the audio device.

NOTE: The track change buttons will function only when paired via Bluetooth®.

Playing Audio

Audio can be played through the speaker via a wireless Bluetooth® connection to a compatible Bluetooth® audio device or by connecting an audio device via the auxiliary port.

Pairing Speaker with a Bluetooth® Audio Device (Fig. A)

1. Place the speaker and the Bluetooth® audio device within 3 feet (1 m) of each other.
2. Turn on the speaker by pressing the power button ❶.
3. Be sure the Bluetooth® audio device has Bluetooth® turned on. (Please consult your device's instruction manual for specific pairing instructions.)
4. Press the Bluetooth® button ❺ on the speaker. This will cause the Bluetooth® status indicator ❻ to blink slowly. During this time, the speaker is trying to find a previously paired device. If found, the Bluetooth® status indicator will stay lit without any blinking.
5. If another device is to be paired, the Bluetooth® status indicator will blink rapidly. While the speaker is displaying the fast blink, it is in pairing mode with a new device.
6. Confirm pairing on your device.
NOTE: If pairing is not confirmed within 5 minutes, the status indicator will stop flashing and will return to a half second interval blink pattern.
7. Once pairing is successful, the Bluetooth® status indicator will turn solid. The speaker will now play audio from your device.

NOTE: Audio output power: 2x10W.

Bluetooth® Status Indicator

Blink Patterns	Status/Mode
Steady blinking (half second interval)	Speaker is unpaired or in connecting mode.
Rapid Blinking	Speaker is in pairing mode and discoverable by your device.
Solid light	Speaker is connected with a device.
No light	Speaker has timed out and/or is off.

Connecting a Previously Paired Bluetooth® Audio Device

If a Bluetooth® device has been previously paired to the speaker, it should automatically reconnect when the speaker is powered on. After 4 seconds, the speaker will go into connecting mode. This is indicated by the Bluetooth® status indicator ❹ blinking steadily. Once the previously paired Bluetooth® device is recognized and connected, the Bluetooth® status indicator will stop blinking and turn solid. If connection does not occur and you are unable to stream audio, please follow the instructions for **Pairing Speaker with a Bluetooth® Audio Device**.

NOTE: The Bluetooth® audio device must have Bluetooth® turned on to automatically pair.

Timeout Functionality (Fig. A)

To conserve battery life, the speaker is designed to power off automatically after a half hour of inactivity. This inactivity could be due to the device being unpaired for a half hour or in the case of the Bluetooth® connection being broken for the same period of time. If the speaker powers off due to inactivity of any kind, refer to **Connecting a Previously Paired Bluetooth® Audio Device**.

NOTE: Optimum Bluetooth® streaming range is roughly 30 feet (9 m) (line of sight) to the speaker, but distances up to 100 feet (30 m) are possible. Physical obstacles, other wireless devices or electromagnetic devices may affect the connection quality.

If Bluetooth® connection is lost due to exceeding time of separation, exceeding the optimum distance, obstacles or otherwise, reconnecting your device with the speaker may be necessary.

Incoming Call

If your phone receives a call while it is connected to the speaker, it will pause the Bluetooth® connection.

Auxiliary Port (Fig. A)

To use the auxiliary port ❷, use a 3.5 mm stereo cable (not included) to connect an audio device, such as a CD player, mobile phone, or portable music player. The sound from the audio device plays through the speaker.

MAINTENANCE

⚠ WARNING: To reduce the risk of serious personal injury, turn unit off and disconnect battery pack before cleaning, making any adjustments or removing/installing attachments or accessories.

Cleaning



WARNING: Blow dirt and dust out of all air vents with clean, dry air at least once a week. To minimize the risk of eye injury, always wear ANSI Z87.1 approved eye protection when performing this.



WARNING: Never use solvents or other harsh chemicals for cleaning the non-metallic parts of the unit. These chemicals may weaken the plastic materials used in these parts. Use a dry cloth. Never let any liquid get inside the unit; never immerse any part of the unit into a liquid.

Accessories



WARNING: Since accessories, other than those offered by DEWALT, have not been tested with this product, use of such accessories with this product could be hazardous. To reduce the risk of injury, only DEWALT recommended accessories should be used with this product.

Recommended accessories for use with your unit could be available at extra cost from your local dealer or authorized service center. If you need assistance in locating any accessory, please contact DEWALT Industrial Tool Co., 701 East Joppa Road, Towson, MD 21286, call 1-800-4-DEWALT (1-800-433-9258) or visit our website: www.dewalt.com.

Repairs

The charger and battery pack are not serviceable.



WARNING: To assure product SAFETY and RELIABILITY, repairs, maintenance and adjustment (including brush inspection and replacement, when applicable) should be performed by a DEWALT factory service center or a DEWALT authorized service center. Always use identical replacement parts.

Register Online

Thank you for your purchase. Register your product now for:

- **WARRANTY SERVICE:** Registering your product will help you obtain more efficient warranty service in case there is a problem with your product.
- **CONFIRMATION OF OWNERSHIP:** In case of an insurance loss, such as fire, flood or theft, your registration of ownership will serve as your proof of purchase.
- **FOR YOUR SAFETY:** Registering your product will allow us to contact you in the unlikely event a safety notification is required under the Federal Consumer Safety Act.

Register online at www.dewalt.com/register.

Three Year Limited Warranty

DEWALT will repair, without charge, any defects due to faulty materials or workmanship for three years from the date of purchase. This warranty does not cover part failure due to normal wear or tool abuse. For further detail of warranty coverage and warranty repair information, visit www.dewalt.com or call 1-800-4-DEWALT (1-800-

433-9258). This warranty does not apply to accessories or damage caused where repairs have been made or attempted by others. THIS LIMITED WARRANTY IS GIVEN IN LIEU OF ALL OTHERS, INCLUDING THE IMPLIED WARRANTY OF MERCHANTABILITY AND FITNESS FOR A PARTICULAR PURPOSE, AND EXCLUDES ALL INCIDENTAL OR CONSEQUENTIAL DAMAGES. Some states do not allow limitations on how long an implied warranty lasts or the exclusion or limitation of incidental or consequential damages, so these limitations may not apply to you. This warranty gives you specific legal rights and you may have other rights which vary in certain states or provinces.

In addition to the warranty, DEWALT tools are covered by our:

1 YEAR FREE SERVICE

DEWALT will maintain the tool and replace worn parts caused by normal use, for free, any time during the first year after purchase.

2 YEARS FREE SERVICE ON DEWALT BATTERY PACKS

DC9071, DC9091, DC9096, DC9182, DC9280, DC9360, DCB120, DCB127, DCB201, DCB203BT, DCB207, DCB361

3 YEARS FREE SERVICE ON DEWALT BATTERY PACKS

DCB200, DCB204, DCB204BT, DCB203, DCB205, DCB205BT, DCB206, DCB230, DCB606, DCB609

NOTE: Battery warranty voided if the battery pack is tampered with in any way. DEWALT is not responsible for any injury caused by tampering and may prosecute warranty fraud to the fullest extent permitted by law.

90 DAY MONEY BACK GUARANTEE

If you are not completely satisfied with the performance of your DEWALT Power Tool, Laser, or Nailer for any reason, you can return it within 90 days from the date of purchase with a receipt for a full refund – no questions asked.

LATIN AMERICA: This warranty does not apply to products sold in Latin America. For products sold in Latin America, see country specific warranty information contained in the packaging, call the local company or see website for warranty information.

FREE WARNING LABEL REPLACEMENT: If your warning labels become illegible or are missing, call 1-800-4-DEWALT (1-800-433-9258) for a free replacement.

***The Bluetooth® word mark and logos are registered trademarks owned by the Bluetooth®, SIG, Inc. and any use of such marks by DEWALT is under license.*

ESPECIFICACIONES

DCR010

20 V Máx*/120V

Wireless Certifications and Safety Information

- This device is either CAN ICES-3(B)/NMB-3(B) or CAN ICES-5(B)/NMB-5(B) compliant.
- This device complies with Part 15 of the FCC Rules and Industry Canada License-exempt RSS standard(s). Operation is subject to the following two conditions: 1) This device may not cause harmful interference, and 2) This device must accept any interference received, including interference that may cause undesired operation.

This equipment has been tested and found to comply with the limits for a Class B digital device, pursuant to Part 15 of the FCC Rules. These limits are designed to provide reasonable protection against harmful interference in a residential installation. This equipment generates, uses and can radiate radio frequency energy and, if not installed and used in accordance with the instructions, may cause harmful interference to radio communications. However, there is no guarantee that interference will not occur in a particular installation. If this equipment does cause harmful interference to radio or television reception, which can be determined by turning the equipment off and on, the user is encouraged to try to correct the interference by one or more of the following measures: 1) Reorient or relocate the receiving antenna, 2) Increase the separation between the equipment and receiver, 3) Connect the equipment into an outlet on a circuit different from that to which the receiver is connected or 4) Consult the dealer or an experienced radio/TV technician for help.

- Changes or modifications to this equipment not expressly approved by the manufacturer could void the user's authority to operate the device.

- Under Industry Canada regulations, this radio transmitter may only operate using an antenna of a type and maximum (or lesser) gain approved for the transmitter by Industry Canada. To reduce potential radio interference to other users, the antenna type and its gain should be so chosen that the equivalent isotropically radiated power (e.i.r.p.) is not more than that necessary for successful communication.
- To comply with FCC and Industry Canada RF exposure limits for general population/uncontrolled exposure, the antenna(s) used for this transmitter must be installed to provide a separation distance of at least 20 cm from all persons and must not be co-located or operated in conjunction with any other antenna or transmitter.

For Bluetooth® Products

- When traveling on airlines, be sure to comply with the airline restrictions on usage of personal electronic devices and Bluetooth®.
- The out of range alert feature has been designed to act as an aid to warn against products getting misplaced or stolen. It is not a security system.
- The connectivity range is up to 100 feet (30.5 meters) depending on environment and location.
- The shortwave radio frequency signals of a Bluetooth® device may impair the operation of other electronic and medical devices (such as pacemakers or hearing aids).

NOTE: The Bluetooth® word mark and logos are registered trademarks owned by the Bluetooth®, SIG, Inc. and any use of such marks is under license. Other trademarks and trade names are those of their respective owners.
This product complies with these standards when operated with a 6 foot (1.8 meters) or shorter extension cord.

Homologation du matériel sans fil et informations sécurité

- Cet appareil est conforme à la norme CAN ICES-3(B)/NMB-3(B) ou CAN ICES-5(B)/NMB-5(B).
- Cet appareil est conforme au paragraphe 15 du règlement du FCC et à la (aux) norme(s) RSS exempté(s) de licence d'Industrie Canada. Son utilisation est soumise aux deux conditions suivantes : 1) Ce dispositif ne doit pas causer d'interférences nuisibles; et 2) Ce dispositif doit accepter toute interférence reçue, y compris toute interférence pouvant causer un fonctionnement indésirable.

Cet équipement a été testé et jugé conforme aux limites propres aux appareils numériques de Classe B, conformément au Paragraphe 15 du règlement du FCC. Ces limites sont destinées à offrir une protection raisonnable contre les interférences nuisibles d'une installation résidentielle. Cet équipement produit, utilise et peut émaner des ondes radiofréquences qui, s'il n'est pas installé et utilisé conformément aux directives, pourront causer des interférences nuisibles aux communications radio. Cependant, en fonction des installations réalisées, l'absence d'interférences n'est pas garantie. Si cet équipement cause des interférences nuisibles à la réception radio ou télévision (ce qui peut être déterminé par la mise sous/hors tension de cet équipement) l'utilisateur est encouragé à tenter de corriger ces interférences en prenant l'une ou plusieurs des mesures suivantes : 1) Réorienter l'antenne de réception ou en changer l'emplacement, 2) Augmenter la distance entre l'équipement et le récepteur, 3) Brancher l'équipement à une prise située sur un circuit différent de celui sur lequel le récepteur est connecté, ou 4) Contacter un revendeur ou consulter un technicien radio/télé qualifié.

- Tout changement ou toute modification à l'appareil qui ne serait pas expressément approuvé par le fabricant pourra annuler les droits de l'utilisateur à employer cet équipement.



- Conformément aux réglementions d'Industrie Canada, cet émetteur radio ne peut fonctionner qu'avec une antenne dont le type et le gain maximal (ou d'une valeur moindre) sont homologués par Industrie Canada pour cet émetteur. Pour réduire toute interférence radio potentielle pouvant affecter les autres utilisateurs, le type d'antenne et ses gains devraient être choisis de façon à ce que la puissance isotrope rayonnée équivalente ne soit pas supérieure aux limites permettant la communication.
- Afin de se conformer aux limites d'exposition aux RF de FCC et Industrie Canada pour la population générale/l'exposition non contrôlée, une ou plusieurs antennes utilisées pour cet émetteur doivent être installées afin d'offrir une distance de séparation d'au moins 20 cm de toutes les personnes et doivent ne pas être situées au même endroit ou utilisées conjointement à tout autre antenne ou émetteur.

Pour les produits Bluetooth^{MD}

- Avant de voyager en avion, s'assurer de suivre les restrictions des compagnies aériennes quant à l'utilisation d'appareils électroniques et Bluetooth^{MD} personnels.
- La fonctionnalité d'alarme hors plage a été conçue pour servir à alerter en cas de perte ou vol de produits. Ce n'est pas un système de sécurité.
- La plage de connectivité peut aller jusqu'à 30.5 meters (100 pieds) en fonction de l'environnement et des lieux.
- Les signaux de radiofréquences ondes courtes d'un appareil Bluetooth^{MD} pourront affecter les opérations d'autres appareils électroniques ou médicaux (comme les stimulateurs cardiaques ou les appareils acoustiques).

REMARQUE : le terme et les logos Bluetooth^{MD} sont des marques déposées appartenant à Bluetooth^{MD}, SIG, Inc. et toute utilisation de ces marques est autorisée par licence. Toute autre marque de commerce et appellation commerciale reste la propriété de leurs propriétaires respectifs.

Ce produit est conforme à ces standards lorsqu'il est utilisé avec un cordon de 1 m 80 (6 pi) ou moins.

Certificaciones inalámbricas e información de seguridad

Este dispositivo cumple con CAN ICES-3(B)/NMB-3(B) o con CAN ICES-5(B)/NMB-5(B).

- Este dispositivo cumple con la Sección 15 de las normas de la Comisión Federal de Comunicaciones (FCC) y las normas RSS de exención de licencia del Ministerio de Industria de Canadá. Su funcionamiento está sujeto a las dos siguientes condiciones: 1) Este dispositivo no puede causar interferencia dañina, y 2) Este dispositivo debe aceptar cualquier interferencia que reciba, incluyendo aquella interferencia que podría producir un funcionamiento no deseado.

Este equipo ha sido probado y se ha demostrado que cumple con los límites establecidos para dispositivos digitales de Clase B, de conformidad con la Sección 15 de las Normas de la FCC. Estos límites están diseñados para ofrecer un nivel razonable de protección contra la interferencia dañina en instalaciones residenciales. Este equipo genera, utiliza y puede emitir energía de radiofrecuencia y, si no se instala y utiliza de acuerdo con las instrucciones proporcionadas, puede producir una interferencia dañina a la comunicación radial. Sin embargo, no existen garantías de que no ocurra interferencia alguna en una instalación en particular. Si este equipo produce interferencia dañina a la recepción radial o de televisión, lo que puede determinarse al apagar y volver a encender el equipo, se pide al usuario que corrija la interferencia implementando una o más de las siguientes medidas: 1) Cambie la orientación o el lugar donde esté ubicada la antena receptora, 2) Aumente el espacio que separa al equipo del receptor, 3) Conecte el equipo a una toma de corriente que esté en un circuito diferente al circuito al que esté conectado el receptor, o 4) Consulte con el distribuidor o con un técnico de radio y televisión con experiencia que pueda ayudarle.

- Los cambios o modificaciones que no estén aprobados expresamente por el fabricante podrían anular la autorización del usuario para utilizar el dispositivo.

- Según el reglamento del Ministerio de Industria de Canadá, este transmisor de radio puede funcionar solamente con una antena del tipo y de la máxima (o menor) ganancia aprobados para el transmisor por el Ministerio de Industria de Canadá. Para reducir la posible interferencia radioeléctrica a otros usuarios, el tipo de antena y su ganancia deberían elegirse de manera que la potencia isotrópica radiada equivalente (p.i.r.e.) no sea mayor que la necesaria para una comunicación satisfactoria.
- Para cumplir con los límites de exposición a radiofrecuencia de FCC e Industry Canada para la población general/exposición no controlada, la(s) antena(s) utilizada(s) para este transmisor debe(n) instalarse para proporcionar una distancia de separación de por lo menos 20 cm de todas las personas y no debe ubicarse ni utilizarse junto con cualquier otra antena o transmisor.

Para productos con Bluetooth[®]

- Al viajar en avión, asegúrese de cumplir con las restricciones de las líneas aéreas acerca del uso de dispositivos electrónicos personales y Bluetooth[®].
- La función de alerta de fuera de alcance ha sido diseñada para servir de ayuda para evitar la pérdida o robo de productos. No es un sistema de seguridad.
- El rango de conectividad es de hasta 30.5 m (100 pies) dependiendo del entorno y la ubicación.
- Las señales de radiofrecuencia de onda corta de un dispositivo Bluetooth[®] pueden afectar el funcionamiento de otros dispositivos médicos y electrónicos (como marcapasos o audífonos).

NOTA: La marca denominativa y los logotipos de Bluetooth[®] son marcas registradas propiedad de Bluetooth[®], SIG, Inc. y todo uso de dichas marcas se hace bajo licencia. Otras marca y nombres comerciales son de sus respectivos propietarios.

Este producto cumple con estas normas cuando se pone en funcionamiento con un alargador de 1.82 m (6 pies) o más corto.