

NOTES:
 1. ALL MATERIALS MUST COMPLY WITH ES100118.

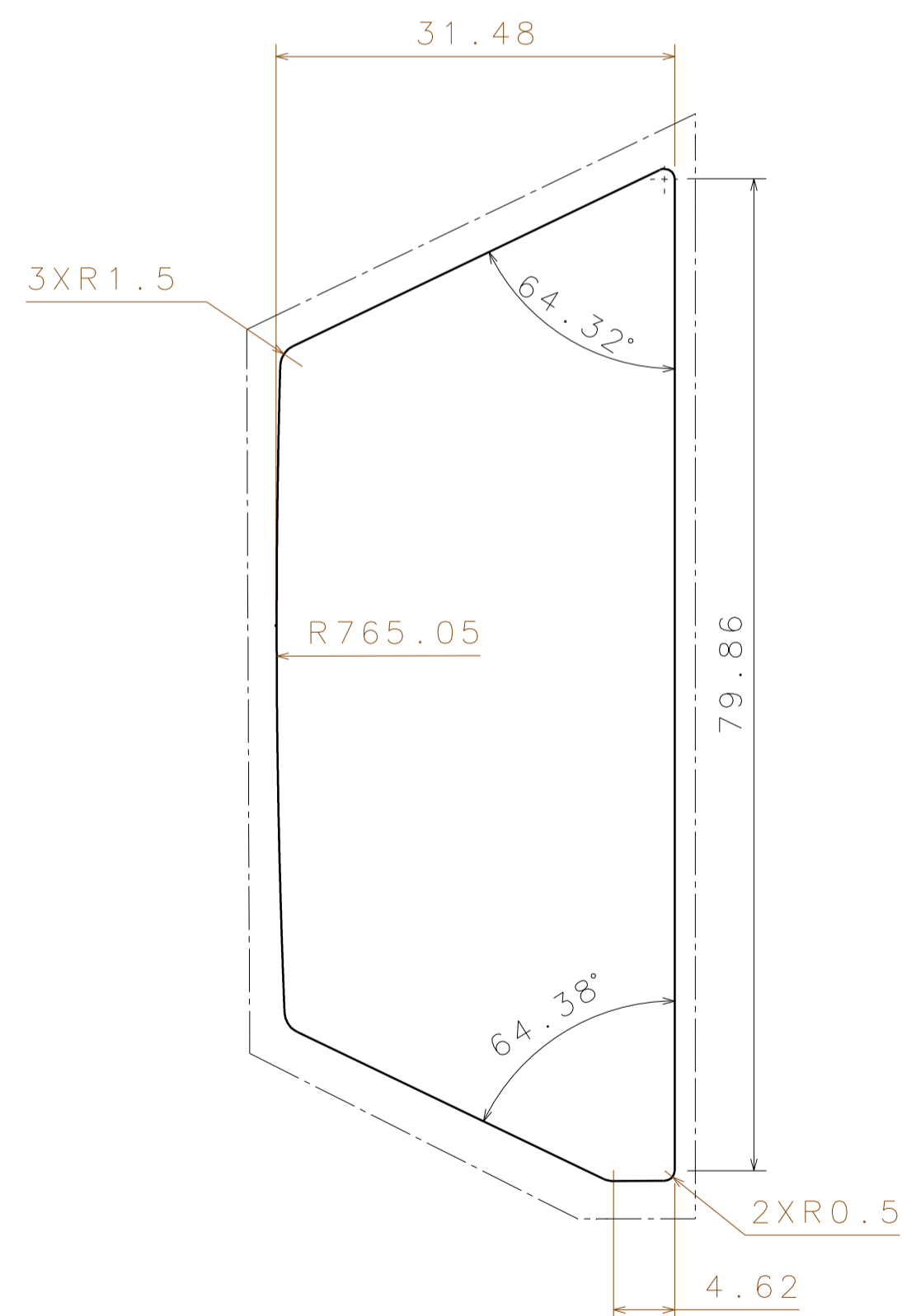

WARNING LABEL
 Scale: 2:1

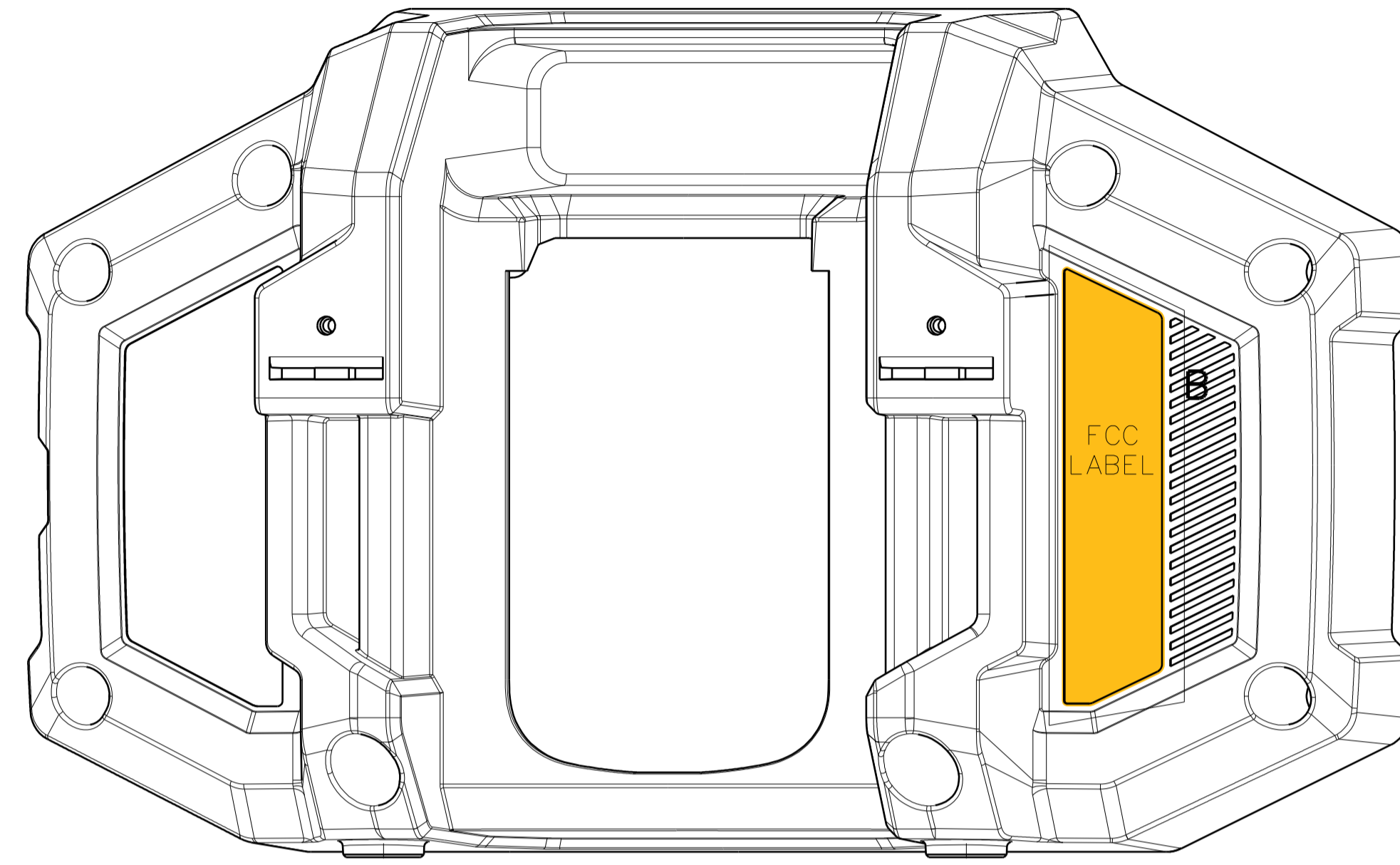
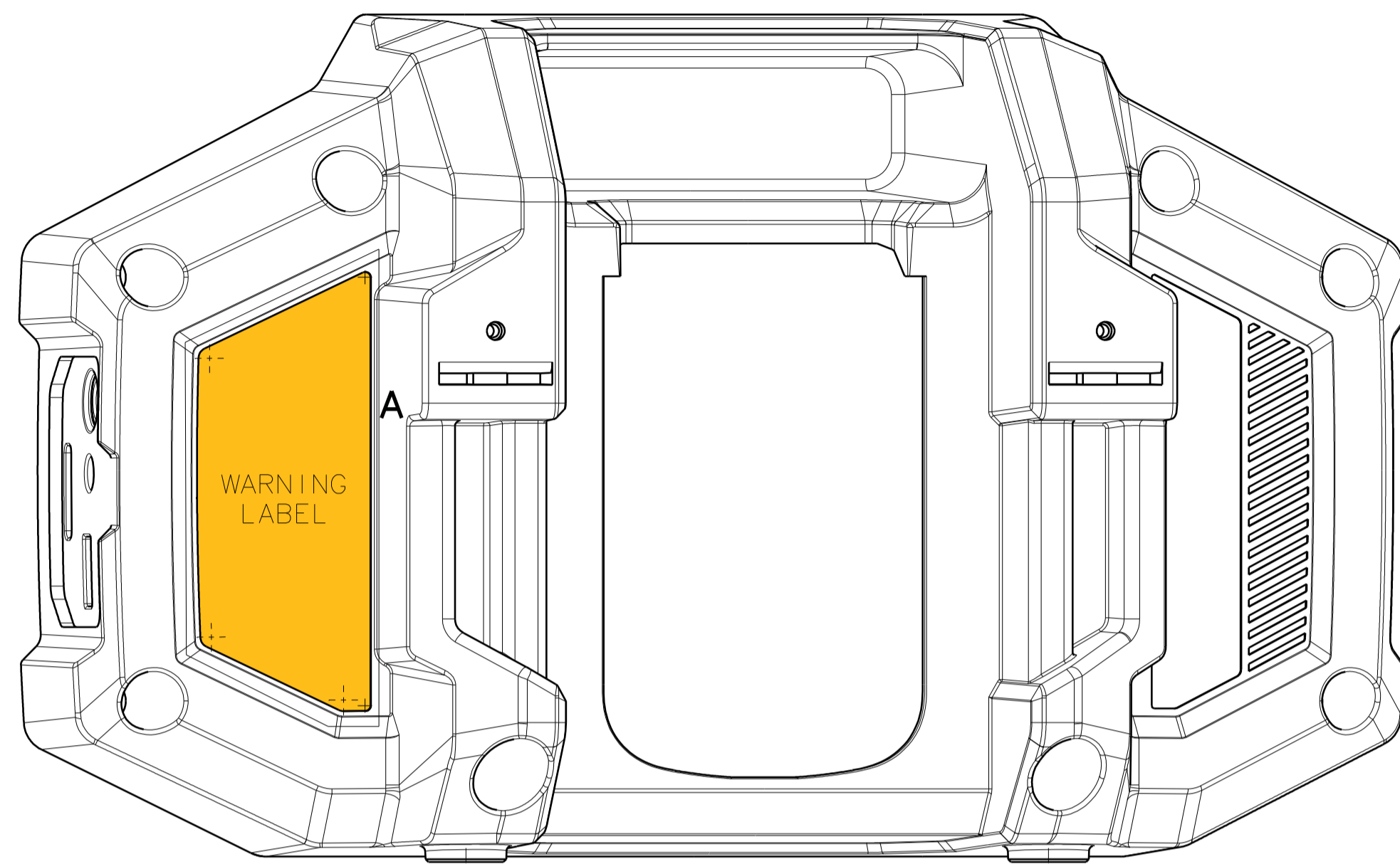
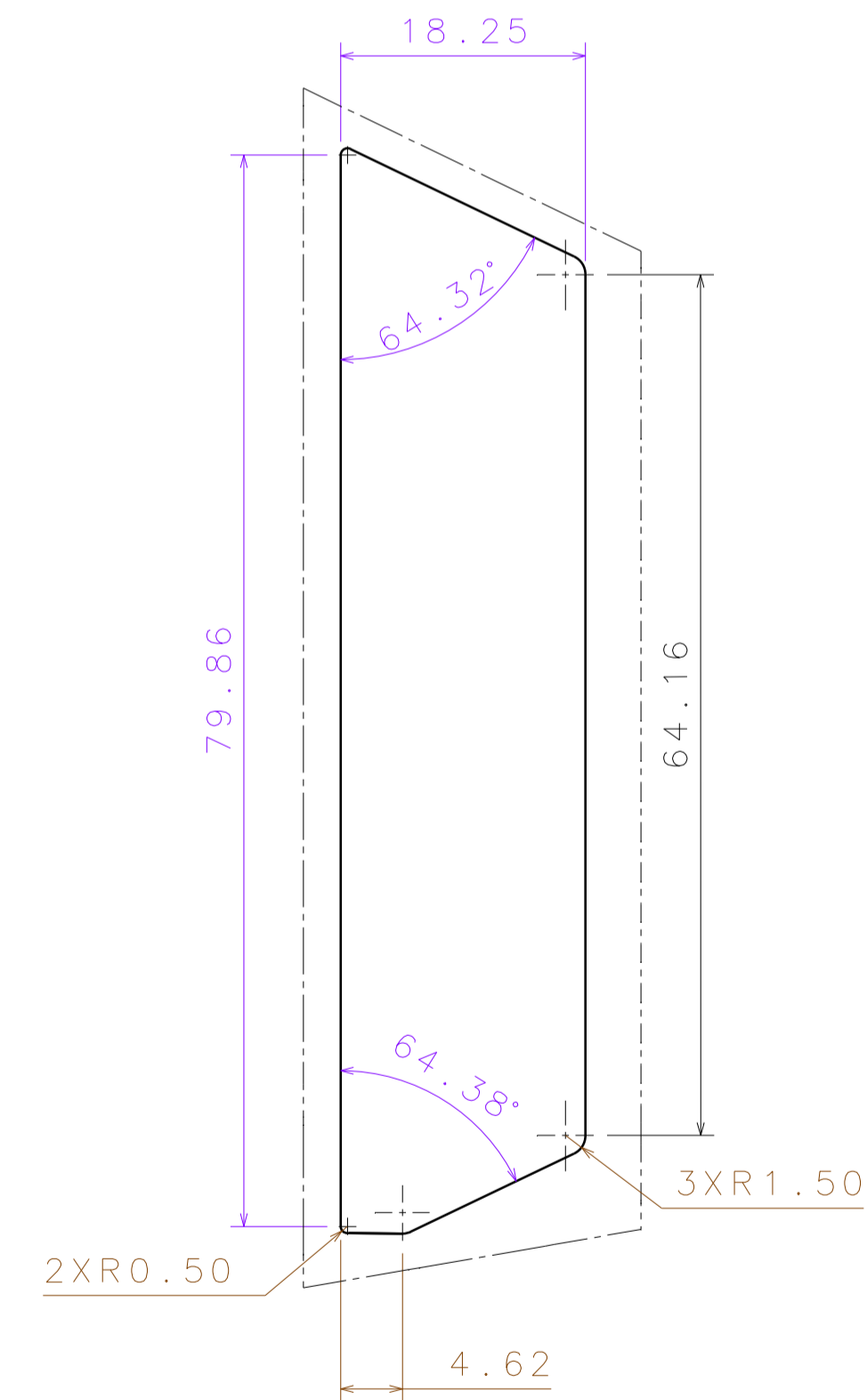

FCC LABEL
 Scale: 2:1

GENERATED FROM: 3D	THIRD ANGLE PROJECTION	TOL UNLESS SPECIFIED 0 & 1 PLC DEC: ± N/A 2 PLC DEC: ± N/A ANGLES: ± N/A	BLACK & DECKER INC.
THIS DOCUMENT IS THE PROPERTY OF BLACK & DECKER INC. THE CONTENTS OF THIS DOCUMENT ARE CONFIDENTIAL AND CONSTITUTE TRADE SECRETS PROPRIETARY TO BLACK & DECKER INC. NEITHER THIS DOCUMENT NOR ITS CONTENTS SHALL BE DISCLOSED TO ANY UNAUTHORIZED PERSON, COPIED OR PUBLISHED WITHOUT PRIOR WRITTEN CONSENT OF BLACK & DECKER INC. COPYRIGHT © 2018 BLACK & DECKER INC.		ALL DIMENSIONS mm	DOC NO:
SIZE: A1	REF SCALE: 1:1	SHEET: 1 OF 1	TITLE: CMCR001 LABEL DIMENSION REVISION: *** VER/ITER: *** CHANGE:
			*** FOR PART DATA REFER TO PART DETAILS REPORT

GENERAL INSTRUCTIONS:
 SUPPLIER TO INSURE CORRECT REVISION LEVEL DWG FOR PRODUCTION. CONTACT SB&D PURCHASING DEPT. FOR LATEST REVISION LEVEL DWG.
 CONTACT SB&D GRAPHICS DESIGN FOR ORIGINAL ARTWORK, COLOR STANDARDS AND CORPORATE GUIDELINES.
 PROOFS OF ALL REVISIONS THAT AFFECT ARTWORK AND ALL NEW COLOR FORMULATIONS MUST BE SUBMITTED TO SB&D GRAPHICS DESIGN FOR APPROVAL PRIOR TO MAKING PRODUCTION PARTS. SEE EP-1006.
 SUPPLIER TO PROVIDE SB&D GRAPHICS DESIGN WITH 6 SAMPLES OF ALL PRODUCTION PARTS. MARK SB&D PART NO. AND REVISION LEVEL.

COLOR VARIATIONS:

■ = PMS Black □ = White (Material)
 ■ = Craftsman Red
 ■ = ANSI Orange (or PMS 165)

LABEL APPLICATION

SURFACE THAT LABEL WILL BE APPLIED TO:

TEXTURED RULED (one curve) OUTDOOR USE
 NON-TEXTURED FLAT INDOOR USE
 COMPOUND

ADHESION: PERMANENT REMOVEABLE OTHER

SYNTHETIC LABEL CONSTRUCTION:

SUPPLIER NAME:	LABEL MATERIAL:
TBD	5 MIL MATTE POLYCARBONATE, SUB-SURFACED PRINTED, 2 MIL ACRYLIC ADHESIVE MATTE TEXTURED

SPECIAL NOTES:

- SERIAL NO'S TO BE SUB-SURFACE PRINTED, 4 DIGITS MIN. (START WITH 1001). RANDOM ORDER ACCEPTABLE. NO TWO NAMEPLATES TO HAVE IDENTICAL NO'S. SEQUENCE TO BE ASSIGNED BY B&D PURCHASING DEPT. (APPLICABLE TO DeWALT PRODUCT ONLY.)
- FINISHED LABEL MUST BE A "UL" AND "CSA" RECOGNIZED LABELING SYSTEM (UL STANDARD: UL969, UL CATEGORY CODE: PGDQ; CSA STANDARD: C22.2 NO. 0.15, CSA CLASS: 7921) AND APPROVED FOR THE SURFACE THAT THE LABEL WILL BE APPLIED TO UNLESS BLACK & DECKER AGREES TO A DEVIATION.
- LABEL MANUFACTURER IS RESPONSIBLE TO PLACE THEIR MANUFACTURER'S CODE ON LABEL IN THE SIZE AND LOCATION INDICATED ON THIS DOCUMENT.
- INK USED MUST BE UV STABILIZED.
- ALL MATERIALS MUST COMPLY WITH ES100118.
- LABELS SHALL BE LEGIBLE, SHALL NOT WORK LOOSE, AND SHALL NOT BECOME CURLED AT THE EDGES AFTER BEING RUBBED BY HAND FOR 15 SECONDS WITH A CLOTH SOAKED IN WATER AND AGAIN FOR 15 SECONDS WITH A CLOTH SOAKED IN PETROLEUM SPIRIT. THE PETROLEUM SPIRIT TO BE USED FOR THE TEST SHALL BE A REAGENT GRADE HEXANE WITH A MINIMUM OF 85% AS N-HEXANE.
- LABEL CONSTRUCTION: WILL MEET THE DURABILITY REQUIREMENTS AND ALSO PROVIDES THE VISUAL CONSISTENCY WITH OTHER DEWALT BRAND PRODUCTS.
- LABEL MUST SATISFY LUBRICATING OIL IMMERSION TEST PER UL969 OR CSA C22.2 # 0.15
- LABEL MUST SATISFY 80C MAX TEMPERATURE RATING PER UL969 OR CSA C22.2 #0.15.
- LABEL MUST BE APPROVED FOR NON-DRY INDOOR USE PER UL969 AND CSA C22.2 NO. 0.15
- ALL SHIPPING BOXES AND ROLL CORES OR LABEL SHEETS MUST BE MARKED WITH VENDOR'S NAME, TRADE NAME, DATE OF MANUFACTURE AND MATERIAL IDENTIFICATION.

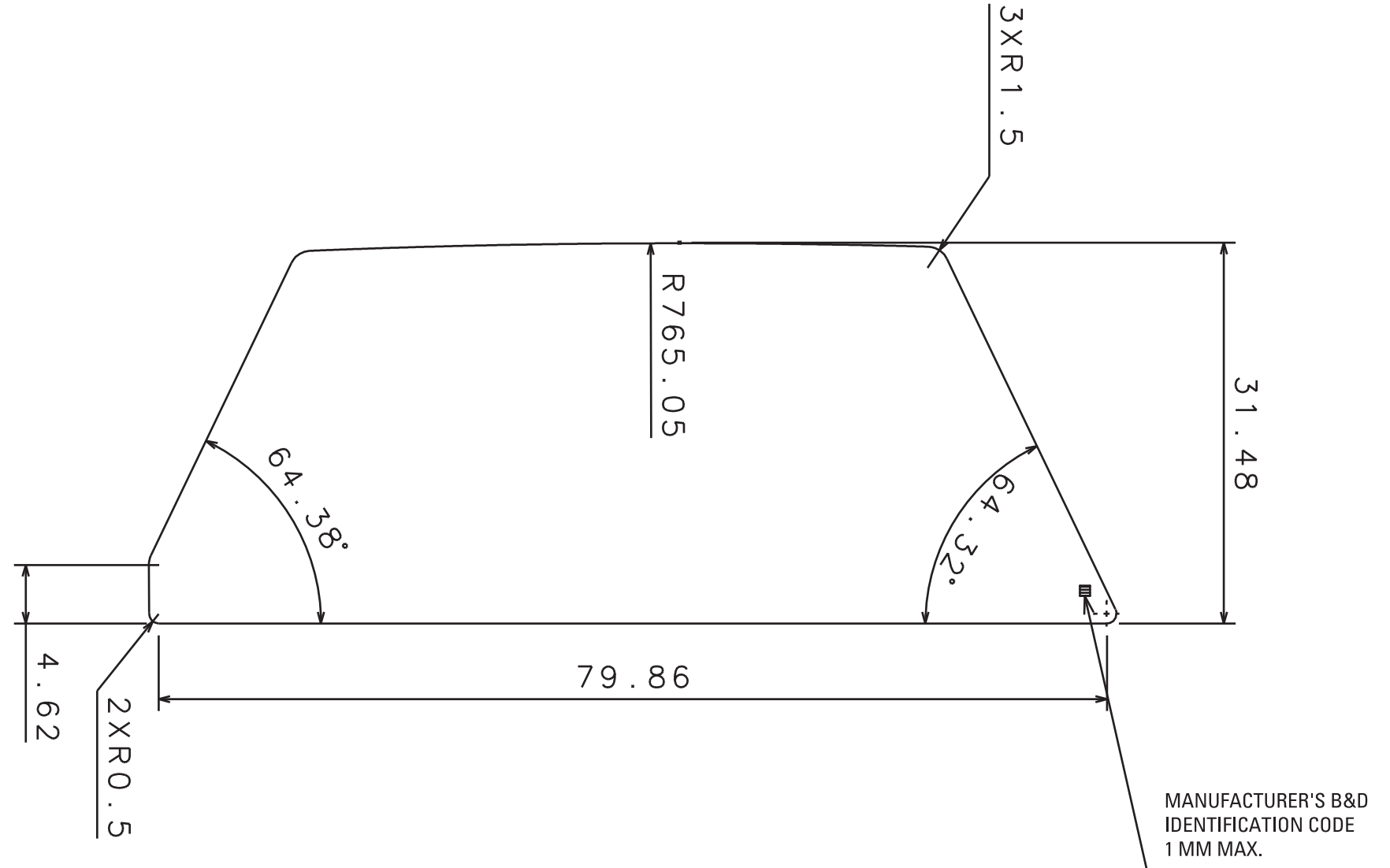

THIS DOCUMENT IS THE PROPERTY OF STANLEY BLACK & DECKER INC. THE CONTENTS OF THIS DOCUMENT ARE CONFIDENTIAL AND CONSTITUTE TRADE SECRETS PROPRIETARY TO STANLEY BLACK & DECKER INC. NEITHER THIS DOCUMENT NOR ITS' CONTENTS SHALL BE DISCLOSED TO ANY UNAUTHORIZED PERSON, COPIED OR PUBLISHED WITHOUT PRIOR WRITTEN CONSENT OF STANLEY BLACK & DECKER INC. COPYRIGHT © 2018 STANLEY BLACK & DECKER INC.

TOL UNLESS SPECIFIED
 0 & 1 PLC DEC: ± 0.4
 ANGLES: ± 1°
 ALL DIMENSIONS mm
 SIZE:
 SHEET: **1 of 1**

StanleyBlack&Decker
 FOR ITEM DATA SEE PRINTED REPORT

N578754

GENERAL INSTRUCTIONS:
 SUPPLIER TO INSURE CORRECT REVISION LEVEL DWG FOR PRODUCTION. CONTACT SB&D PURCHASING DEPT. FOR LATEST REVISION LEVEL DWG.
 CONTACT SB&D GRAPHICS DESIGN FOR ORIGINAL ARTWORK, COLOR STANDARDS AND CORPORATE GUIDELINES.
 PROOFS OF ALL REVISIONS THAT AFFECT ARTWORK AND ALL NEW COLOR FORMULATIONS MUST BE SUBMITTED TO SB&D GRAPHICS DESIGN FOR APPROVAL PRIOR TO MAKING PRODUCTION PARTS. SEE EP-1006.
 SUPPLIER TO PROVIDE SB&D GRAPHICS DESIGN WITH 6 SAMPLES OF ALL PRODUCTION PARTS. MARK SB&D PART NO. AND REVISION LEVEL.

COLOR VARIATIONS:

= Craftsman Red = White (Material)

LABEL APPLICATION

SURFACE THAT LABEL WILL BE APPLIED TO:

<input type="checkbox"/> TEXTURED	<input checked="" type="checkbox"/> RULED (one curve)	<input type="checkbox"/> OUTDOOR USE
<input checked="" type="checkbox"/> NON-TEXTURED	<input type="checkbox"/> FLAT	<input checked="" type="checkbox"/> INDOOR USE
<input type="checkbox"/> COMPOUND		

ADHESION: PERMANENT REMOVEABLE OTHER

SYNTHETIC LABEL CONSTRUCTION:

SUPPLIER NAME:	LABEL MATERIAL:
TBD	5 MIL MATTE POLYCARBONATE, SUB-SURFACED PRINTED, 2 MIL ACRYLIC ADHESIVE MATTE TEXTURED

SPECIAL NOTES:

- FINISHED LABEL MUST BE A "UL" AND "CSA" RECOGNIZED LABELING SYSTEM (UL STANDARD: UL969, UL CATEGORY CODE: PGDQ2; CSA STANDARD: C22.2 NO. 0.15, CSA CLASS: 7921) AND APPROVED FOR THE SURFACE THAT THE LABEL WILL BE APPLIED TO UNLESS BLACK & DECKER AGREES TO A DEVIATION.
- LABEL MANUFACTURER IS RESPONSIBLE TO PLACE THEIR MANUFACTURER'S CODE ON LABEL IN THE SIZE AND LOCATION INDICATED ON THIS DOCUMENT.
- INK USED MUST BE UV STABILIZED.
- ALL MATERIALS MUST COMPLY WITH ES100118.
- LABELS SHALL BE LEGIBLE, SHALL NOT WORK LOOSE, AND SHALL NOT BECOME CURLED AT THE EDGES AFTER BEING RUBBED BY HAND FOR 15 SECONDS WITH A CLOTH SOAKED IN WATER AND AGAIN FOR 15 SECONDS WITH A CLOTH SOAKED IN PETROLEUM SPIRIT. THE PETROLEUM SPIRIT TO BE USED FOR THE TEST SHALL BE A REAGENT GRADE HEXANE WITH A MINIMUM OF 85% AS N-HEXANE.
- LABEL CONSTRUCTION: WILL MEET THE DURABILITY REQUIREMENTS AND ALSO PROVIDES THE VISUAL CONSISTENCY WITH OTHER DEWALT BRAND PRODUCTS.
- LABEL MUST SATISFY LUBRICATING OIL IMMERSION TEST PER UL969 OR CSA C22.2 # 0.15
- LABEL MUST SATISFY 80C MAX TEMPERATURE RATING PER UL969 OR CSA C22.2 #0.15.
- LABEL MUST BE APPROVED FOR NON-DRY INDOOR USE PER UL969 AND CSA C22.2 NO. 0.15
- ALL SHIPPING BOXES AND ROLL CORES OR LABEL SHEETS MUST BE MARKED WITH VENDOR'S NAME, TRADE NAME, DATE OF MANUFACTURE AND MATERIAL IDENTIFICATION.

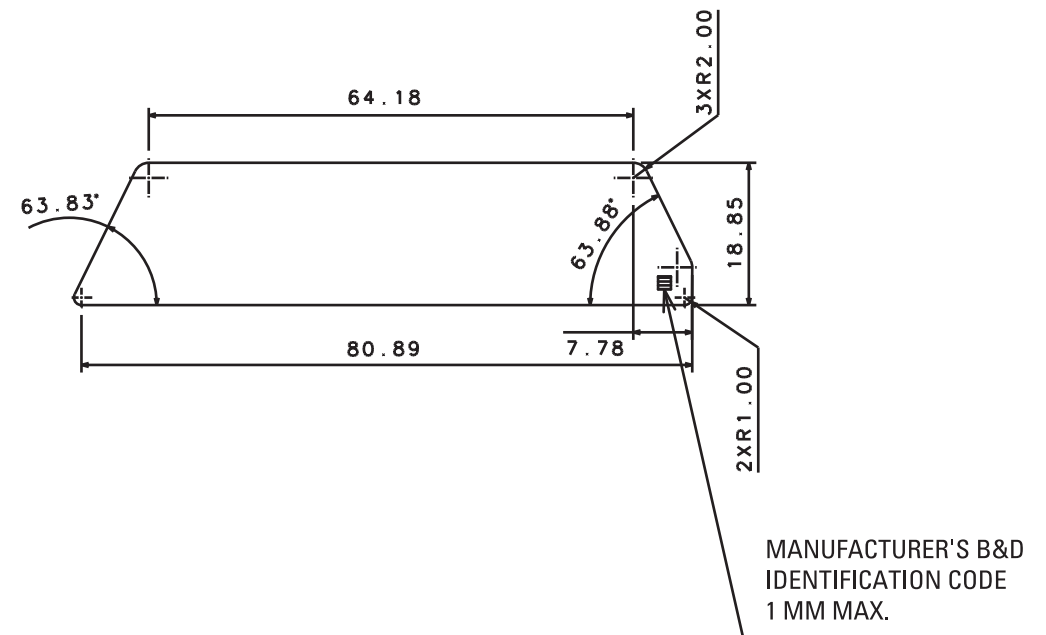

MODEL: CMC001 **FCC ID: YJ7CMCR001** **IC: 9082A-CMCR001**
 THIS DEVICE COMPLIES WITH PART 15 OF THE FCC RULES. OPERATION IS SUBJECT TO THE FOLLOWING TWO CONDITIONS: (1) THIS DEVICE MAY NOT CAUSE HARMFUL INTERFERENCE, AND (2) THIS DEVICE MUST ACCEPT ANY INTERFERENCE RECEIVED, INCLUDING INTERFERENCE THAT MAY CAUSE UNDESIRABLE OPERATION. THIS DEVICE ALSO COMPLIES TO ICES-003 AND BETS-7 CANADIAN STANDARDS. L'APPAREIL EST EGALEMENT CONFORME A LA NMB-003 ET A LA NTMR-7 CANADIENNES.

THIS DOCUMENT IS THE PROPERTY OF STANLEY BLACK & DECKER INC. THE CONTENTS OF THIS DOCUMENT ARE CONFIDENTIAL AND CONSTITUTE TRADE SECRETS PROPRIETARY TO STANLEY BLACK & DECKER INC. NEITHER THIS DOCUMENT NOR ITS' CONTENTS SHALL BE DISCLOSED TO ANY UNAUTHORIZED PERSON, COPIED OR PUBLISHED WITHOUT PRIOR WRITTEN CONSENT OF STANLEY BLACK & DECKER INC. COPYRIGHT © 2018 STANLEY BLACK & DECKER INC.

TOL UNLESS SPECIFIED
 0 & 1 PLC DEC: ± 0.4
 ANGLES: ± 1°
 ALL DIMENSIONS mm

SIZE:

SHEET: **1 of 1**

StanleyBlack&Decker

FOR ITEM DATA SEE PRINTED REPORT

NXXXXXX