

# TEST REPORT

Applicant Name : Zhongshan Donlim Weili Electrical Appliances Co.,Ltd.  
 Address : Fusha Industrial Park, Fusha Town, Zhongshan City, Guangdong Province, China  
 Report Number : SZ2221009-45800E-EM-01  
 FCC ID: YI4DWMW001G

## Test Standard (s)

FCC Part 18

## Sample Description

Product Type: Cordless Microwave  
 Model No.: MW001G  
 Trade Mark: Makita  
 Date Received: 2022-10-09  
 Date of Test: 2022-10-13 to 2022-10-14  
 Report Date: 2022-11-02

Test Result:	Pass*
--------------	-------

\* In the configuration tested, the EUT complied with the standards above.

## Prepared and Checked By:

*Zeki Ma*

Zeki.Ma  
 EMC Engineer

## Approved By:

*Candy Li*

Candy Li  
 EMC Engineer

Note: This report may contain data that are not covered by the A2LA accreditation and are marked with an asterisk "★".

Shenzhen Accurate Technology Co., Ltd. is not responsible for the authenticity of any test data provided by the applicant. Data included from the applicant that may affect test results are marked with an asterisk "★". Customer model name, addresses, names, trademarks etc. are not considered data.

This report cannot be reproduced except in full, without prior written approval of the Company. Unless otherwise stated the results shown in this test report refer only to the sample(s) tested. This report is valid only with a valid digital signature. The digital signature may be available only under the Adobe software above version 7.0.

### Shenzhen Accurate Technology Co., Ltd.

1/F., Building A, Changyuan New Material Port, Science & Industry Park, Nanshan District, Shenzhen, Guangdong, P.R. China  
 Tel: +86 755-26503290 Fax: +86 755-26503396 Web: www.atc-lab.com

## **TABLE OF CONTENTS**

<b>GENERAL INFORMATION.....</b>	<b>3</b>
PRODUCT DESCRIPTION FOR EQUIPMENT UNDER TEST (EUT).....	3
OBJECTIVE .....	3
TEST METHODOLOGY .....	3
MEASUREMENT UNCERTAINTY .....	3
TEST FACILITY .....	4
<b>OPERATING CONDITION/TEST CONFIGURATION.....</b>	<b>5</b>
JUSTIFICATION .....	5
EUT EXERCISE SOFTWARE .....	5
SPECIAL ACCESSORIES .....	5
EQUIPMENT MODIFICATIONS .....	5
SUPPORT EQUIPMENT LIST AND DETAILS .....	5
EXTERNAL CABLE LIST AND DETAILS .....	5
CONFIGURATION OF TEST SETUP .....	5
BLOCK DIAGRAM OF TEST SETUP .....	6
<b>SUMMARY OF TEST RESULT .....</b>	<b>7</b>
<b>TEST EQUIPMENT LIST .....</b>	<b>8</b>
<b>FCC §18.313, §1.1310, §2.1091- MAXIMUM PERMISSIBLE EXPOSURE.....</b>	<b>9</b>
APPLICABLE STANDARD .....	9
MEASUREMENT.....	9
<b>RADIATION HAZARD MEASUREMENT .....</b>	<b>10</b>
APPLICABLE STANDARD .....	10
ENVIRONMENTAL CONDITIONS .....	10
INPUT POWER.....	10
LOAD FOR CORDLESS MICROWAVES.....	10
RF OUTPUT POWER MEASUREMENT .....	10
OPERATING FREQUENCY MEASUREMENT .....	11
<b>RADIATED EMISSIONS.....</b>	<b>15</b>
APPLICABLE STANDARD .....	15
EUT SETUP.....	15
EMI TEST RECEIVER SETUP AND SPECTRUM ANALYZER SETUP.....	16
TEST PROCEDURE .....	16
CORRECTED AMPLITUDE & MARGIN CALCULATION .....	16
TEST DATA AND PLOTS .....	16

## GENERAL INFORMATION

### Product Description for Equipment under Test (EUT)

Product	Cordless Microwave
Tested Model	MW001G
Voltage Range	DC 36V-40V Max
Highest operating frequency	2450 MHz
Microwave Output power	500W /350W
Sample serial number	SZ2221009-45800E-EM-S1 (Assigned by ATC)
Sample/EUT Status	Good condition

### Objective

This report is in accordance with Part 2-Subpart J, and Part 18-Subparts A, B and C of the Federal Communication Commissions rules and regulations.

The objective of the manufacturer is to determine compliance with FCC Part 18 limits.

### Test Methodology

All measurements contained in this report were conducted with MP-5, FCC Methods of Measurements of Radio Noise Emissions from ISM Equipment, February 1986. All measurements were performed at Shenzhen Accurate Technology Co., Ltd. The radiated testing was performed at an antenna-to-EUT distance of 3 meters. Each test item follows test standards and with no deviation.

### Measurement Uncertainty

Parameter		Uncertainty
RF Frequency		$0.082 \times 10^{-7}$
Emissions, Radiated	30MHz - 1GHz	4.28dB
	1GHz - 18GHz	4.98dB
	18GHz - 26.5GHz	5.06dB
Temperature		1°C
Humidity		6%
Supply voltages		0.4%

*Note: The extended uncertainty given in this report is obtained by combining the standard uncertainty times the coverage factor K with the 95% confidence interval. Otherwise required by the applicant or Product Regulations, Decision Rule in this report did not consider the uncertainty.*

## **Test Facility**

The test site used by Shenzhen Accurate Technology Co., Ltd. to collect test data is located on the 1/F., Building A, Changyuan New Material Port, Science & Industry Park, Nanshan District, Shenzhen, Guangdong, P.R. China.

The test site has been approved by the FCC under the KDB 974614 D01 and is listed in the FCC Public Access Link (PAL) database, FCC Registration No.: 708358, the FCC Designation No.: CN1189. Accredited by American Association for Laboratory Accreditation (A2LA) The Certificate Number is 4297.01.

Listed by Innovation, Science and Economic Development Canada (ISED), the Registration Number is 5077A.

## OPERATING CONDITION/TEST CONFIGURATION

### Justification

The EUT was operated at maximum (continuous) RF output power. The loads consisted of water in a glass beaker in the amounts specified in the test procedure.

### EUT Exercise Software

No exercise software was used.

### Special Accessories

No special accessory was used.

### Equipment Modifications

No modifications were made to the EUT tested.

### Support Equipment List and Details

Manufacturer	Description	Model	Serial Number
Unknown	Glass beaker	Unknown	Unknown
Alt	Battery*2	BL4080F	Unknown
Unknown	Resistance	3Ω	Unknown

### External Cable List and Details

Cable Description	Length (m)	From/Port	To
Unshielded detachable USB cable	0.95	EUT	Resistance

### Configuration of Test Setup

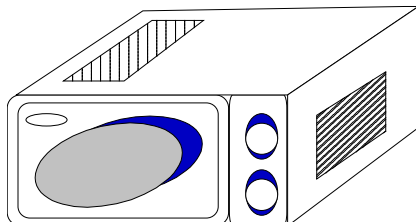

### Block Diagram of Test Setup

For Radiated Emission:

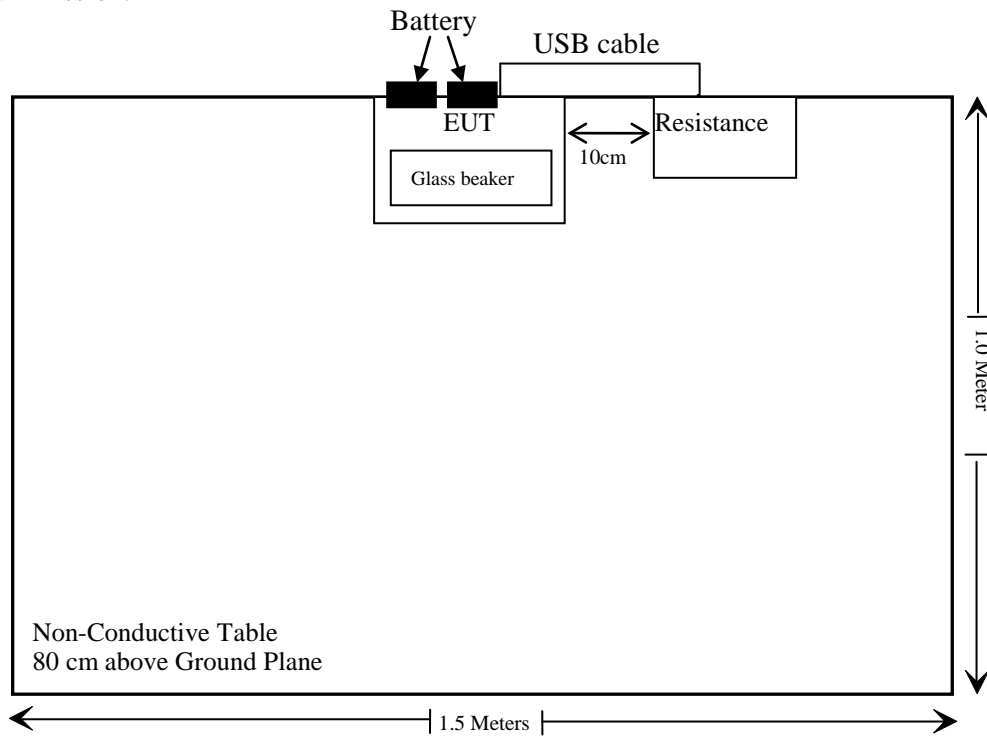

**SUMMARY OF TEST RESULT**

<b>FCC Rules</b>	<b>Description of Test</b>	<b>Results</b>
FCC §18.313, §1.1310, §2.1091	Maximum Permissible Exposure	Compliant
FCC §18.307	AC Line Conducted Emissions	Not Applicable
FCC/OST MP-5 FCC §18.301	Radiation Hazard Measurement	Compliant
FCC §18.305	Field Strength	Compliant

Note: The device is powered by battery only.

**TEST EQUIPMENT LIST**

Manufacturer	Description	Model	Serial Number	Calibration Date	Calibration Due Date
Radiated Emissions Test					
Rohde & Schwarz	Test Receiver	ESR	102725	2021/12/13	2022/12/12
Rohde & Schwarz	Spectrum Analyzer	FSV-40	101949	2021/12/13	2022/12/12
A.H. Systems, inc.	Preamplifier	PAM-0118P	135	2021/11/09	2022/11/08
SONOMA INSTRUMENT	Amplifier	310 N	186131	2021/11/09	2022/11/08
Schwarzbeck	Bilog Antenna	VULB9163	9163-323	2021/07/06	2024/07/05
Schwarzbeck	Horn Antenna	BBHA9120D	9120D-1067	2020/01/05	2023/01/04
Schwarzbeck	HORN ANTENNA	BBHA9170	9170-359	2020/01/05	2023/01/04
Quinstar	Amplifier	QLW-18405536-J0	15964001002	2021/11/11	2022/11/10
Unknown	RF Coaxial Cable	No.10	N050	2021/12/14	2022/12/13
Unknown	RF Coaxial Cable	No.11	N1000	2021/12/14	2022/12/13
Unknown	RF Coaxial Cable	No.12	N040	2021/12/14	2022/12/13
Unknown	RF Coaxial Cable	No.13	N300	2021/12/14	2022/12/13
Unknown	RF Coaxial Cable	No.14	N800	2021/12/14	2022/12/13
Unknown	RF Coaxial Cable	No.15	N600	2021/12/14	2022/12/13
Unknown	RF Coaxial Cable	No.16	N650	2021/12/14	2022/12/13
Radiated Emission Test Software: e3 19821b (V9)					
Radiation Hazard Measurement					
OHAUS	Electronic Scale	R2000-6	8339220237	2021/12/25	2022/12/24
MC	Thermometer	Unknown	ATCE-197	2021/10/31	2022/10/30
Rohde & Schwarz	Spectrum Analyzer	FSV-40	101949	2021/12/13	2022/12/12
Schwarzbeck	Horn Antenna	BBHA9120D	9120D-1067	2020/01/05	2023/01/04
Unknown	RF Coaxial Cable	No.13	N300	2021/12/14	2022/12/13
Unknown	RF Coaxial Cable	No.14	N800	2021/12/14	2022/12/13
UNI-T	DC Power Supply	UTP8305B	10584	NCR	NCR
Fluke	Desktop Multi Meter	45	7664009	2021/12/14	2022/12/13
Maximum Permissible Exposure					
ETS	Microwave Survery Meter	1501	123654	2022/3/11	2023/03/10

\* **Statement of Traceability:** Shenzhen Accurate Technology Co., Ltd. attests that all calibrations have been performed in accordance to requirements that traceable to National Primary Standards and International System of Units (SI).



## FCC §18.313, §1.1310, §2.1091- MAXIMUM PERMISSIBLE EXPOSURE

### Applicable Standard

According to subpart §1.1310, systems operating under the provisions of this section shall be operated in a manner that ensures that the public is not exposed to radio frequency energy level in excess of the Commission's guidelines.

Limits for Maximum Permissible Exposure (MPE) (§1.1310, §2.1091)

<b>(B) Limits for General Population/Uncontrolled Exposure</b>				
<b>Frequency Range (MHz)</b>	<b>Electric Field Strength (V/m)</b>	<b>Magnetic Field Strength (A/m)</b>	<b>Power Density (mW/cm<sup>2</sup>)</b>	<b>Averaging Time (minutes)</b>
0.3–1.34	614	1.63	*(100)	30
1.34–30	824/f	2.19/f	*(180/f <sup>2</sup> )	30
30–300	27.5	0.073	0.2	30
300–1500	/	/	f/1500	30
1500–100,000	/	/	1.0	30

f = frequency in MHz; \* = Plane-wave equivalent power density;

### Measurement

#### Environmental Conditions

<b>Temperature:</b>	24 °C
<b>Relative Humidity:</b>	45 %
<b>ATM Pressure:</b>	101.0 kPa

*The testing was performed by Zeki Ma on 2022-10-14.*

Radiation leakage was measured in the as-received condition with the oven door closed using a microwave leakage meter.

A 275 mL water load was placed in the center of the oven and the oven was operated at maximum output power.

There was no microwave leakage exceeding a power level of 0.1mW/cm<sup>2</sup> observed at any point 5 cm or more from the external surface of the oven.

A maximum of 1.0 mW/cm<sup>2</sup> is allowed in accordance with the applicable Federal Standards. Hence, microwave leakage in the as-received condition with the oven door closed was below the maximum allowed.

## RADIATION HAZARD MEASUREMENT

### Applicable Standard

FCC §18.301 & FCC/OST MP-5

### Environmental Conditions

<b>Temperature:</b>	26 °C
<b>Relative Humidity:</b>	58%
<b>ATM Pressure:</b>	101.0kPa

*The testing was performed by Zeki Ma on 2022-10-13*

### Input Power

Note: The device is powered by battery only.

### Load for Cordless Microwaves

For all measurements, the energy developed by the oven was absorbed by a dummy load consisting of a quantity of tap water in a beaker. If the oven was provided with a shelf or other utensil support, this support was in its initial normal position. For ovens rated at 1000 watts or less power output, the beaker contained quantities of water as listed in the following subparagraphs. For ovens rated at more than 1000 watts output, each quantity was increased by 50% for each 500watts or fraction thereof in excess of 1000 watts. Additional beakers were used if necessary.

- Load for power output measurement: 1000 milliliters of water in the beaker located in the center of the oven.
- Load for frequency measurement: 1000 milliliters of water in the beaker located in the center of the oven.
- Load for measurement of radiation on second and third harmonic: Two loads, one of 700 and the other of 300 milliliters, of water are used. Each load is tested both with the beaker located in the center of the oven and with it in the right front corner.

### RF Output Power Measurement

A cylindrical container of borosilicate glass is used for the test. It has a maximum thickness of 3 mm, an external diameter of approximately 190 mm and a height of approximately 90 mm. The mass of the container is determined.

At the start of the test, the oven and the empty container are at ambient temperature. Water having an initial temperature is used for the test. The water temperature is measured immediately before it is poured into the container.

A quantity of  $1000 \text{ g} \pm 5 \text{ g}$  of water is added to the container and its actual mass obtained. The container is then immediately placed in the centre of the oven shelf, which is in its lowest normal position. The oven is operated and the time for the water temperature to attain is measured. The oven is then switched off and the final water temperature is measured within 60 s.

$m_w$ (g)	$m_c$ (g)	$T_0$ (°C)	$T_1$ (°C)	$T_2$ (°C)	$t$ (s)
1000	377.0	24	10.5	15.4	40

RF Output Power =  $(4.187 \times 1000 \times (15.4-10.5) + 0.55 \times 377.0 \times (15.4-24)) / 40 = 468.327$ Watts

$P$  is the microwave power output, in watts;

$m_w$  is the mass of the water, in grams;

$m_c$  is the mass of the container, in grams;

$T_0$  is the ambient temperature, in degrees Celsius;

$T_1$  is the initial temperature of the water, in degrees Celsius;

$T_2$  is the final temperature of the water, in degrees Celsius;

$t$  is the heating time, in seconds, excluding the magnetron filament heating-up time.

The measurement output power was found to be less than 500 watts. Therefore, in accordance with Section 18.305 of Subpart-C, the measured out-of-band emissions were compared to the limit of 25 $\mu$ V/meter at a 300-meter measurement distance.

The measured output power was found to exceed 500 watts. Therefore, in accordance with Section 18.305 of Subpart-C, the measured out-of-band emissions were compared with the limit calculated as following:

$$LFS = 25 * \text{SQRT} (\text{Power Output}/500)$$

## Operating Frequency Measurement

### Variation in Operating Frequency with Time

The operating frequency was measured using a spectrum analyzer. Starting with the EUT at room temperature, a 1000mL water load was placed in the center of the oven and the oven was operated at maximum output power. The fundamental operating frequency was monitored until the water load was reduced to 20 percent of the original load.

The results of this test are as follows:

Frequency at Start time (MHz)	Frequency at End time (MHz)
2474.75	2479.09

Refer to data pages for details of the variation in operating frequency with time measurement.

**Start time:**

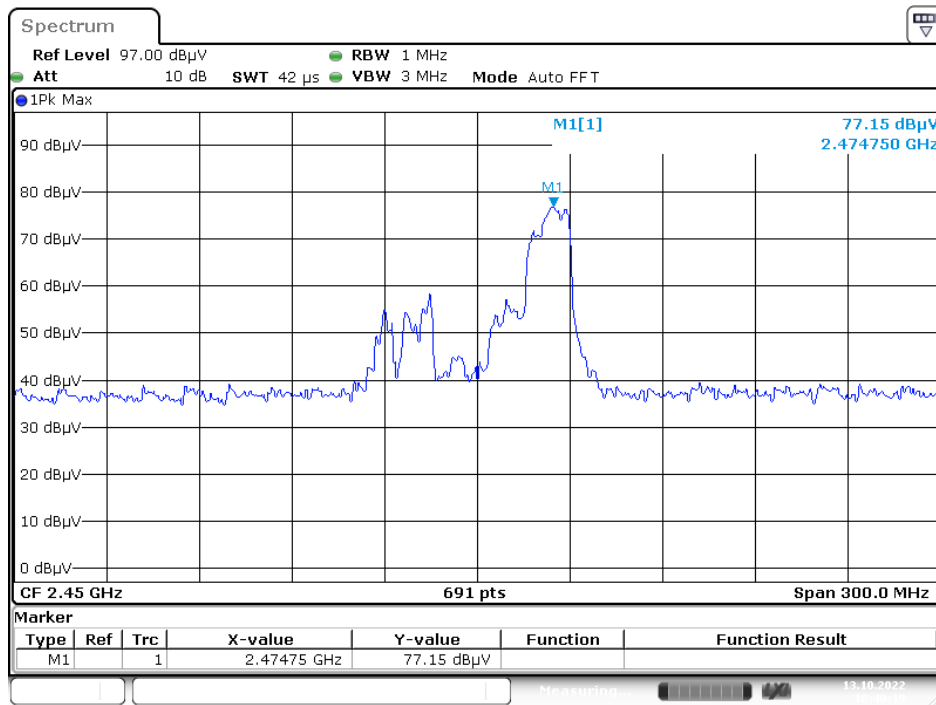

Date: 13.OCT.2022 18:40:19

**End time:**

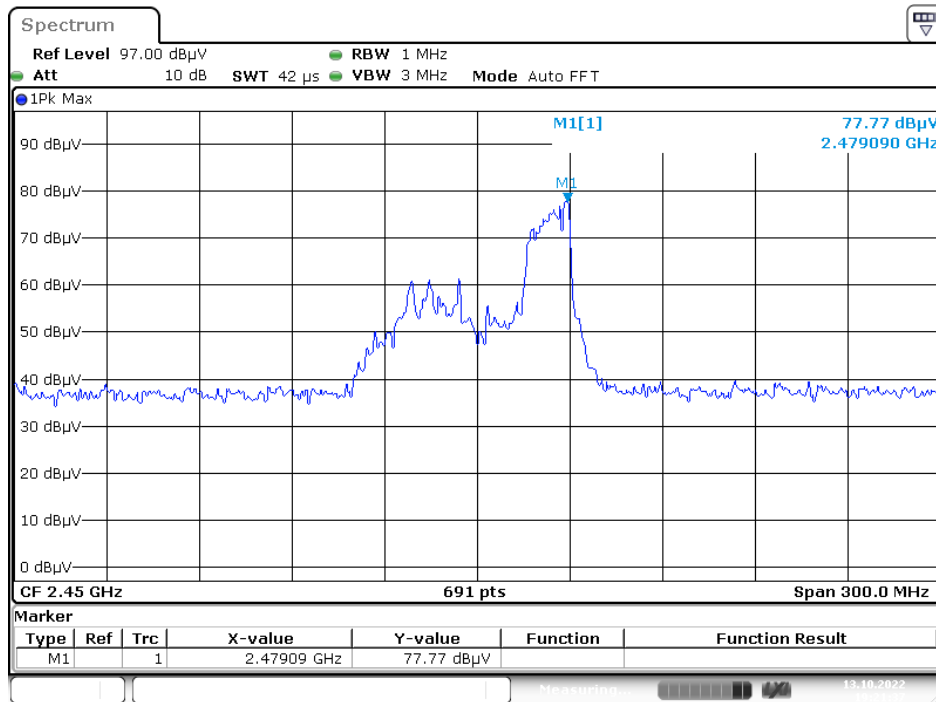

Date: 13.OCT.2022 19:21:37

### Variation in Operating Frequency with Line Voltage

The EUT was operated / warmed by at least 10 minutes of use with a 1000 mL water load at room temperature at the beginning of the test. Then the operating frequency was monitored as the input voltage was varied between 80 and 125 percent of the nominal rating.

The results of this test are as follows:

Line voltage varied from 36 V<sub>DC</sub> to 40 V<sub>DC</sub>.

(Low voltage) Frequency (MHz)	(High voltage) Frequency (MHz)
2474.75	2479.09

Please refer to following pages for details of the variation in operating frequency with line voltage measurement.

#### Low Voltage:

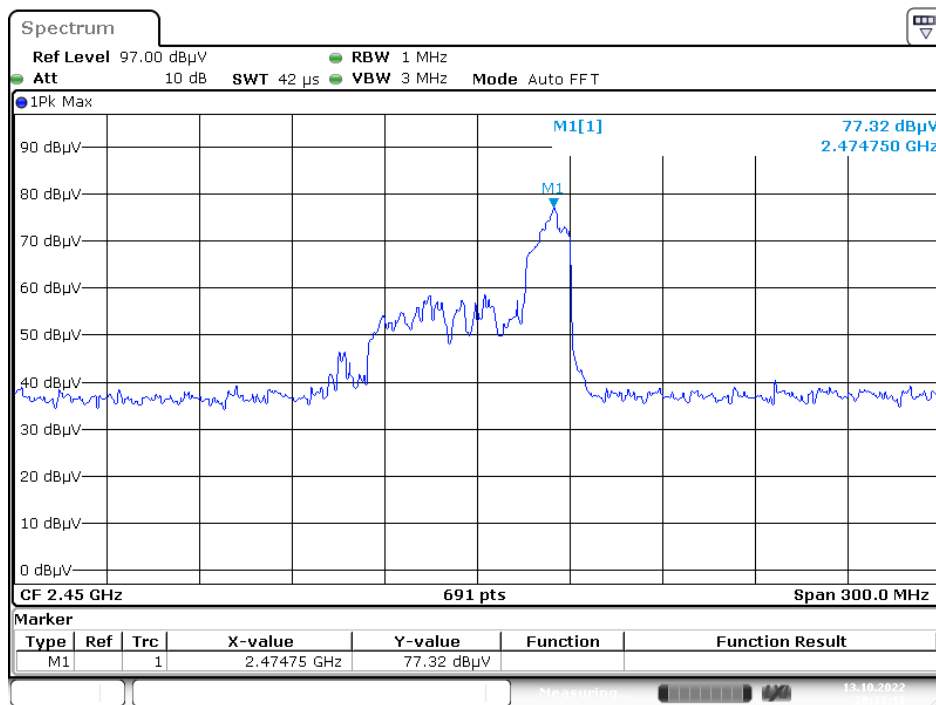

Date: 13.OCT.2022 20:33:11

**High Voltage:**

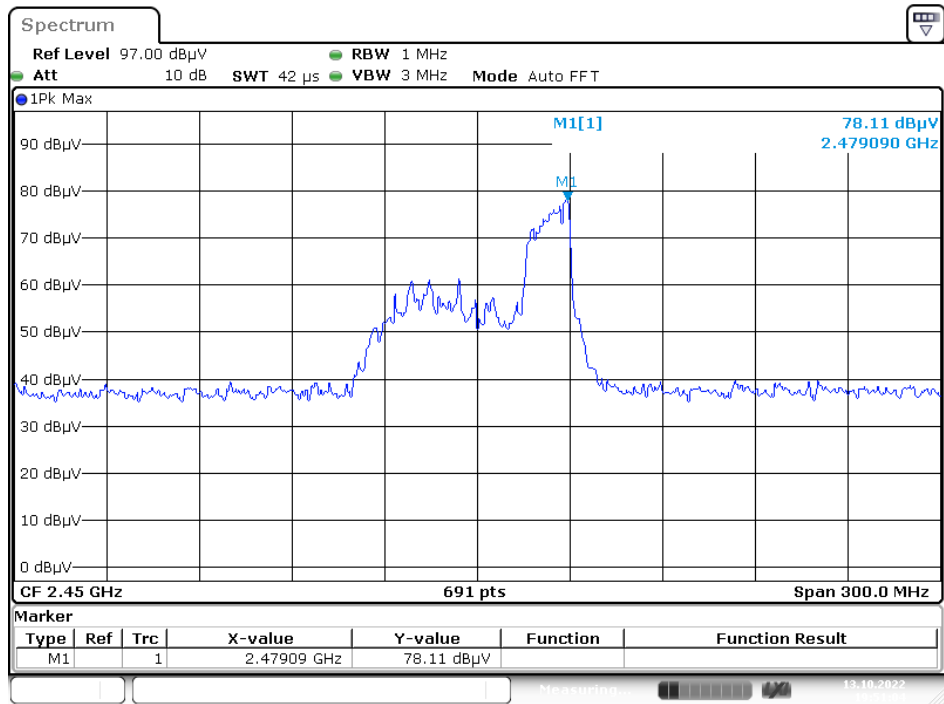

Date: 13.OCT.2022 19:51:04

## RADIATED EMISSIONS

### Applicable Standard

FCC §18.305 and FCC §18.309

### EUT Setup

#### Below 1GHz:

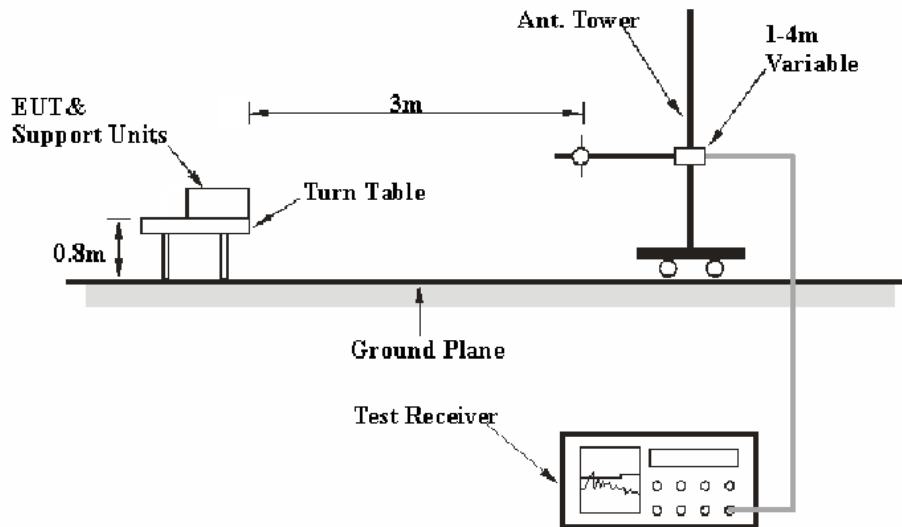

#### Above 1GHz:

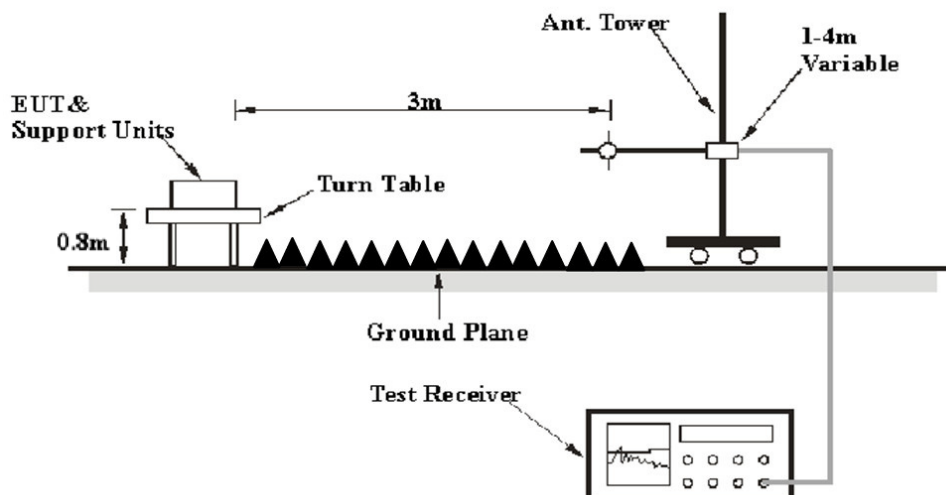

The radiated emission tests were performed in the 3 meters chamber test site, using the setup accordance with the FCC MP-5. The specification used was the FCC part 18 limits.

## EMI Test Receiver Setup and Spectrum Analyzer Setup

The system was investigated from 30 MHz to 25 GHz.

During the radiated emission test, the EMI test receiver and Spectrum Analyzer were set with the following configurations:

Frequency Range	RBW	Video B/W	IF B/W	Measurement
30MHz – 1000 MHz	100 kHz	300 kHz	120kHz	QP
Above 1 GHz	1MHz	3 MHz	/	PK.
	1MHz	10 Hz	/	Ave.

## Test Procedure

Maximizing procedure was performed on the six (6) highest emissions to ensure that the EUT complied with all installation combinations.

The EUT was in the normal (naïve) operating mode during the final qualification test to represent the worst results.

## Corrected Amplitude & Margin Calculation

The Factor is calculated by adding the Antenna Factor and Cable Loss, and subtracting the Amplifier Gain. The basic equation is as follows:

$$\text{Factor} = \text{Antenna Factor} + \text{Cable Loss} - \text{Amplifier Gain}$$

The “**Over Limit/Margin**” column of the following data tables indicates the degree of compliance with the applicable limit. For example, an Over Limit/margin of -7dB means the emission is 7dB below the limit. The equation for calculation is as follows:

$$\begin{aligned} \text{Over Limit/Margin} &= \text{Level} / \text{Corrected Amplitude} - \text{Limit} \\ \text{Level} / \text{Corrected Amplitude} &= \text{Read Level} + \text{Factor} \end{aligned}$$

## Test Data and Plots

### Environmental Conditions

<b>Temperature:</b>	28~30 °C
<b>Relative Humidity:</b>	57~59%
<b>ATM Pressure:</b>	101.3kPa

*The testing was performed by Level Li on 2022-10-13 and 2022-10-14.*

*Test mode: Microwave (max power)*



30 MHz – 1 GHz

Horizontal

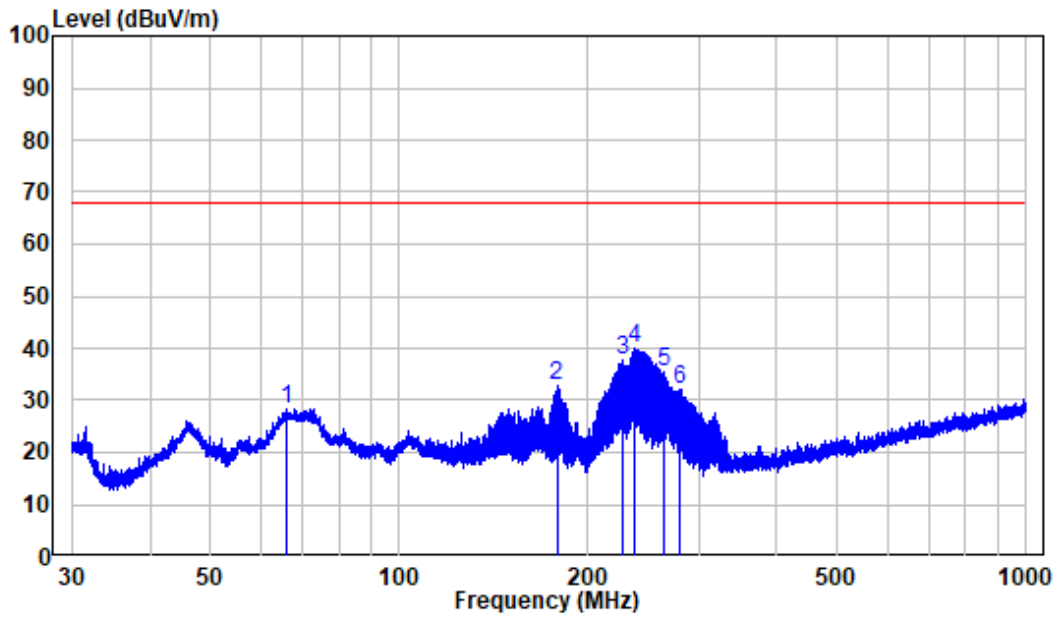

Site : chamber  
 Condition: 3m HORIZONTAL  
 Job No. : SZ2221009-45800E-EM  
 Test Mode: Microwave

	Freq	Factor	Read Level	Level	Limit Line	Over Limit	Remark
	MHz	dB/m	dBuV	dBuV/m	dBuV/m	dB	
1	66.063	-12.92	41.18	28.26	67.95	-39.69	Peak
2	178.289	-12.94	45.76	32.82	67.95	-35.13	Peak
3	226.695	-11.21	49.00	37.79	67.95	-30.16	Peak
4	237.476	-10.93	51.02	40.09	67.95	-27.86	Peak
5	264.398	-10.47	46.06	35.59	67.95	-32.36	Peak
6	279.779	-9.59	41.57	31.98	67.95	-35.97	Peak

**Vertical**

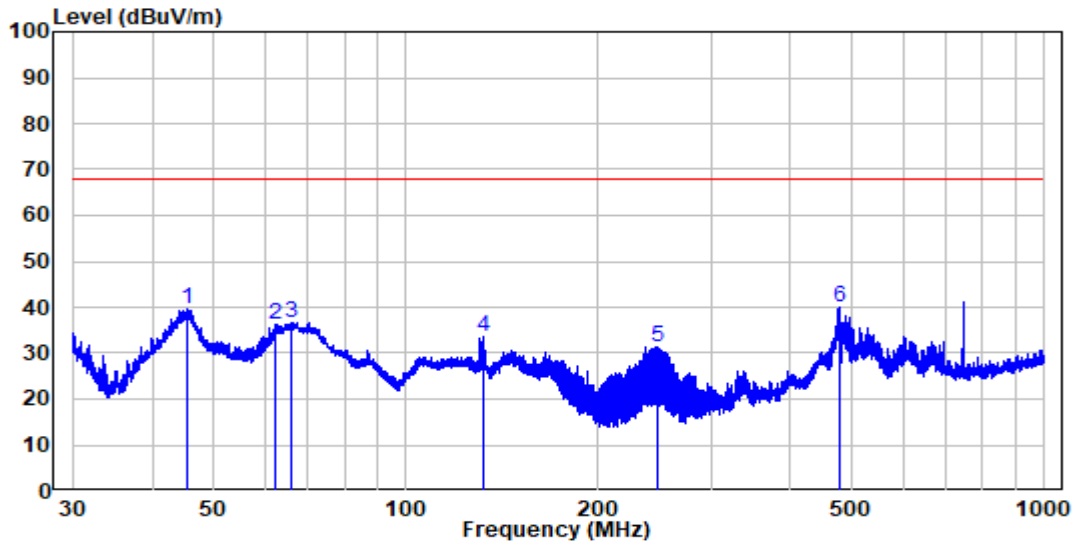

Site : chamber  
 Condition: 3m VERTICAL  
 Job No. : SZ2221009-45800E-EM  
 Test Mode: Microwave

	Freq	Factor	Read Level	Level	Limit	Over	Remark
	MHz	dB/m	dBuV	dBuV/m	dBuV/m	dB	
1	45.236	-9.95	49.55	39.60	67.95	-28.35	Peak
2	62.486	-11.61	48.02	36.41	67.95	-31.54	Peak
3	66.179	-12.97	49.69	36.72	67.95	-31.23	Peak
4	131.758	-14.97	48.46	33.49	67.95	-34.46	Peak
5	247.791	-10.67	42.16	31.49	67.95	-36.46	Peak
6	476.542	-5.30	45.47	40.17	67.95	-27.78	Peak

**1 - 25 GHz:**

Frequency (MHz)	Receiver		Turntable Degree	Rx Antenna		Corrected Factor (dB/m)	Corrected Amplitude (dBμV/m)	Limit (dBμV/m)	Margin (dB)
	Reading (dBμV)	PK/QP/AV		Height (m)	Polar (H/V)				
For Band edge and spurious emissions									
2127.000	55.11	AV	190	2.0	H	-7.22	47.89	67.95	-20.06
2127.000	43.58	AV	334	2.1	V	-7.22	36.36	67.95	-31.59
2814.125	48.26	AV	199	1.6	H	-6.25	42.01	67.95	-25.94
2814.125	48.55	AV	350	1.9	V	-6.25	42.30	67.95	-25.65
4237.250	38.44	AV	5	1.0	H	-5.02	33.42	67.95	-34.53
4237.250	38.11	AV	347	1.4	V	-5.02	33.09	67.95	-34.86
For second and third harmonics									
700ml water in center									
4943.063	41.09	AV	284	2.2	H	-3.06	38.03	67.95	-29.92
4943.063	49.66	AV	215	1.8	V	-3.06	46.60	67.95	-21.35
8643.188	42.55	AV	348	1.5	H	5.02	47.57	67.95	-20.38
8643.188	35.44	AV	213	1.6	V	5.02	40.46	67.95	-27.49
300ml water in center									
4943.063	43.07	AV	283	1.9	H	-3.06	40.01	67.95	-27.94
4943.063	51.49	AV	334	2.1	V	-3.06	48.43	67.95	-19.52
8643.188	44.56	AV	135	1.5	H	5.02	49.58	67.95	-18.37
8643.188	37.45	AV	306	2.2	V	5.02	42.47	67.95	-25.48

## Note:

Factor = Antenna factor (RX) + Cable Loss - Amplifier Factor

Corrected Amplitude = Factor + Reading

Margin = Corrected Amplitude - Limit

**\*\*\*\*\* END OF REPORT \*\*\*\*\***