



FCC Test Report

APPLICANT : BLU Products, Inc.
EQUIPMENT : Mobile phone
BRAND NAME : BLU
MODEL NAME : VIVO 5
FCC ID : YHLBLUVIVO5
STANDARD : FCC 47 CFR FCC Part 15 Subpart B
CLASSIFICATION : Certification

The product was received on Jan. 06, 2016 and testing was completed on Feb. 16, 2016. We, SPORTON INTERNATIONAL (KUNSHAN) INC., would like to declare that the tested sample has been evaluated in accordance with the test procedures given in ANSI C63.4-2014 and has been in compliance with the applicable technical standards.

The test results in this report apply exclusively to the tested model / sample. Without written approval of SPORTON INTERNATIONAL (KUNSHAN) INC., the test report shall not be reproduced except in full.

James Huang

Prepared by: James Huang / Manager

Jones Tsai

Approved by: Jones Tsai / Manager



SPORTON INTERNATIONAL (KUNSHAN) INC.

No. 3-2, PingXiang Road, Kunshan, Jiangsu Province, P. R. China



TABLE OF CONTENTS

REVISION HISTORY.....	3
SUMMARY OF TEST RESULT	4
1. GENERAL DESCRIPTION	5
1.1. Applicant.....	5
1.2. Manufacturer	5
1.3. Product Feature of Equipment Under Test	5
1.4. Product Specification subjective to this standard.....	6
1.5. Modification of EUT	7
1.6. Test Location	7
1.7. Applicable Standards	7
2. TEST CONFIGURATION OF EQUIPMENT UNDER TEST.....	8
2.1. Test Mode	8
2.2. Connection Diagram of Test System	10
2.3. Support Unit used in test configuration and system.....	11
2.4. EUT Operation Test Setup	11
3. TEST RESULT.....	12
3.1. Test of AC Conducted Emission Measurement	12
3.2. Test of Radiated Emission Measurement	18
4. LIST OF MEASURING EQUIPMENT	24
5. UNCERTAINTY OF EVALUATION	25
APPENDIX A. SETUP PHOTOGRAPHS	



REVISION HISTORY

REPORT NO.	VERSION	DESCRIPTION	ISSUED DATE
FC610605-01	Rev. 01	This project is FCC change ID application, BLU Products, Inc. market their product under their own identification. Based on the similarity between two products, the test result is not affected; all test cases were leveraged on original report (Sporton Report Number FC610605).	Feb. 18, 2016



SUMMARY OF TEST RESULT

Report Section	FCC Rule	IC Rule	Description	Limit	Result	Remark
3.1	15.107	ICES003 Section 6.1	AC Conducted Emission	< 15.107 limits < ICES003 6.1 limits	PASS	Under limit 10.46 dB at 0.560 MHz
3.2	15.109	ICES003 Section 6.2	Radiated Emission	< 15.109 limits < ICES003 6.2 limits	PASS	Under limit 4.35 dB at 49.710 MHz for Quasi-Peak



1. General Description

1.1. Applicant

BLU Products, Inc.
10814 NW 33rd St # 100 Doral, FL 33172

1.2. Manufacturer

BLU Products, Inc.
10814 NW 33rd St # 100 Doral, FL 33172

1.3. Product Feature of Equipment Under Test

Product Feature	
Equipment	Mobile phone
Brand Name	BLU
Model Name	VIVO 5
FCC ID	YHLBLUVIVO5
EUT supports Radios application	GSM/GPRS/EGPRS/WCDMA/HSPA/HSPA+/DC-HSDPA/LTE/ WLAN 2.4GHz 802.11b/g/n HT20/HT40/ Bluetooth v3.0+EDR/Bluetooth v4.0 LE
IMEI Code	Conduction: 354147042001165/354147042036161 Radiation: 354147042001165/354147042036161
HW Version	VIVO 5_Mainboard_P3.0
SW Version	VIVO 5_0303_V5520
EUT Stage	Pre-Production

Remark: The above EUT's information was declared by manufacturer. Please refer to the specifications or user's manual for more detailed description.



1.4. Product Specification subjective to this standard

Product Specification subjective to this standard	
Tx Frequency	GSM850: 824.2 MHz ~ 848.8 MHz GSM1900: 1850.2 MHz ~ 1909.8MHz WCDMA Band V: 826.4 MHz ~ 846.6 MHz WCDMA Band IV: 1712.4 MHz ~ 1752.6 MHz WCDMA Band II: 1852.4 MHz ~ 1907.6 MHz LTE Band 2 : 1850.7 MHz ~ 1909.3 MHz LTE Band 4 : 1710.7 MHz ~ 1754.3 MHz LTE Band 7 : 2502.5 MHz ~ 2567.5 MHz 802.11b/g/n: 2412 MHz ~ 2462 MHz Bluetooth: 2402 MHz ~ 2480 MHz
Rx Frequency	GSM850: 869.2 MHz ~ 893.8 MHz GSM1900: 1930.2 MHz ~ 1989.8 MHz WCDMA Band V: 871.4 MHz ~ 891.6 MHz WCDMA Band IV: 2112.4 MHz ~ 2152.6 MHz WCDMA Band II: 1932.4 MHz ~ 1987.6 MHz LTE Band 2 : 1930.7 MHz ~ 1989.3 MHz LTE Band 4 : 2110.7 MHz ~ 2154.3 MHz LTE Band 7 : 2622.5 MHz~ 2687.5 MHz 802.11b/g/n: 2412 MHz ~ 2462 MHz Bluetooth: 2402 MHz ~ 2480 MHz GPS : 1.57542 GHz
Antenna Type	WWAN : Fixed Internal Antenna WLAN : Fixed Internal Antenna Bluetooth : Fixed Internal Antenna GPS : Fixed Internal Antenna
Type of Modulation	GSM: GMSK GPRS: GMSK EDGE(MCS 0-4): GMSK / (MCS 5-9): 8PSK WCDMA : QPSK (Uplink) HSDPA/DC-HSDPA : QPSK (Uplink) HSUPA : QPSK (Uplink) HSPA+ : 16QAM LTE: QPSK / 16QAM 802.11b : DSSS (DBPSK / DQPSK / CCK) 802.11g/n : OFDM (BPSK / QPSK / 16QAM / 64QAM) Bluetooth v4.0 LE : GFSK Bluetooth (1Mbps) : GFSK Bluetooth (2Mbps) : $\pi/4$ -DQPSK Bluetooth (3Mbps) : 8-DPSK GPS : BPSK



1.5. Modification of EUT

No modifications are made to the EUT during all test items.

1.6. Test Location

Test Site	SPORTON INTERNATIONAL (KUNSHAN) INC.		
Test Site Location	No. 3-2, PingXiang Road, Kunshan, Jiangsu Province, P. R. China TEL: +86-0512-5790-0158 FAX: +86-0512-5790-0958		
Test Site No.	Sporton Site No.		FCC/IC Registration No.
	CO01-KS	03CH03-KS	306251/4086E

Note: The test site complies with ANSI C63.4 2014 requirement.

1.7. Applicable Standards

According to the specifications of the manufacturer, the EUT must comply with the requirements of the following standards:

- ♦ FCC 47 CFR FCC Part 15 Subpart B
- ♦ ANSI C63.4-2014
- ♦ IC ICES-003 Issue 5
- ♦ IC RSS-Gen Issue 4

Remark: All test items were verified and recorded according to the standards and without any deviation during the test.



2. Test Configuration of Equipment Under Test

2.1. Test Mode

The EUT has been associated with peripherals pursuant to ANSI C63.4-2014 and configuration operated in a manner tended to maximize its emission characteristics in a typical application.

Frequency range investigated: conduction (150 kHz to 30 MHz), radiation (30MHz to the 5th harmonic of the highest fundamental frequency or to 40 GHz, whichever is lower).

The following tables are showing the test modes as the worst cases and recorded in this report.

Item	EUT Configuration	Test Condition		
		EMI AC	EMI RE<1G	EMI RE≥1G
1.	Charging Mode (EUT with adapter)	☒	☒	☒
2.	Data application transferred mode (EUT connected with notebook)	☒	☒	☒

Abbreviations:

- EMI AC: AC conducted emissions
- EMI RE ≥ 1G: EUT radiated emissions ≥ 1GHz
- EMI RE < 1G: EUT radiated emissions < 1GHz

Remark: For signal above 1GHz, the worst case was test item 1.



Test Items	EUT Configure Mode	Function Type
AC Conducted Emission	1/2	<p>Mode 1: WCDMA Band II Idle + Bluetooth Idle + WLAN Idle + USB Cable (Charging from Adapter) + Earphone + Camera (Front) + SIM1<Fig.1></p> <p>Mode 2: GSM850 Idle + Bluetooth Idle + WLAN Idle + USB Cable (Charging from Adapter) + Earphone + MPEG4 + SIM2<Fig.1></p> <p>Mode 3: LTE Band 7 Idle + Bluetooth Idle + WLAN Idle + USB Cable (Data Link with Notebook) + Earphone + GPS Rx + SIM1<Fig.2></p> <p>Mode 4: GSM850 Idle + Bluetooth Idle + WLAN Idle + USB Cable (Charging from Adapter) + Earphone + Camera (Back) + SIM2<Fig.1></p>
Radiated Emissions < 1GHz	1/2	<p>Mode 1: WCDMA Band II Idle + Bluetooth Idle + WLAN Idle + USB Cable (Charging from Adapter) + Earphone + Camera (Front) + SIM1<Fig.1></p> <p>Mode 2: GSM850 Idle + Bluetooth Idle + WLAN Idle + USB Cable (Charging from Adapter) + Earphone + MPEG4 + SIM2<Fig.1></p> <p>Mode 3: LTE Band 7 Idle + Bluetooth Idle + WLAN Idle + USB Cable (Data Link with Notebook) + Earphone + GPS Rx + SIM1<Fig.2></p> <p>Mode 4: GSM850 Idle + Bluetooth Idle + WLAN Idle + USB Cable (Charging from Adapter) + Earphone + Camera (Back) + SIM2<Fig.1></p>
Radiated Emissions ≥ 1GHz	1/2	<p>Mode 1: GSM850 Idle + Bluetooth Idle + WLAN Idle + USB Cable (Charging from Adapter) + Earphone + MPEG4 + SIM2<Fig.1></p> <p>Mode 2: LTE Band 7 Idle + Bluetooth Idle + WLAN Idle + USB Cable (Data Link with Notebook) + Earphone + GPS Rx + SIM1<Fig.2></p>

Remark:

1. The worst case of AC is mode 2; and the USB Link mode of AC is mode 3, the test data of these modes are reported.
2. The worst case of RE < 1G is mode 2; and the USB Link mode of RE is mode 3; the test data of this mode is reported.
3. Data Link with notebook means data application transferred mode between EUT and notebook.

2.2. Connection Diagram of Test System

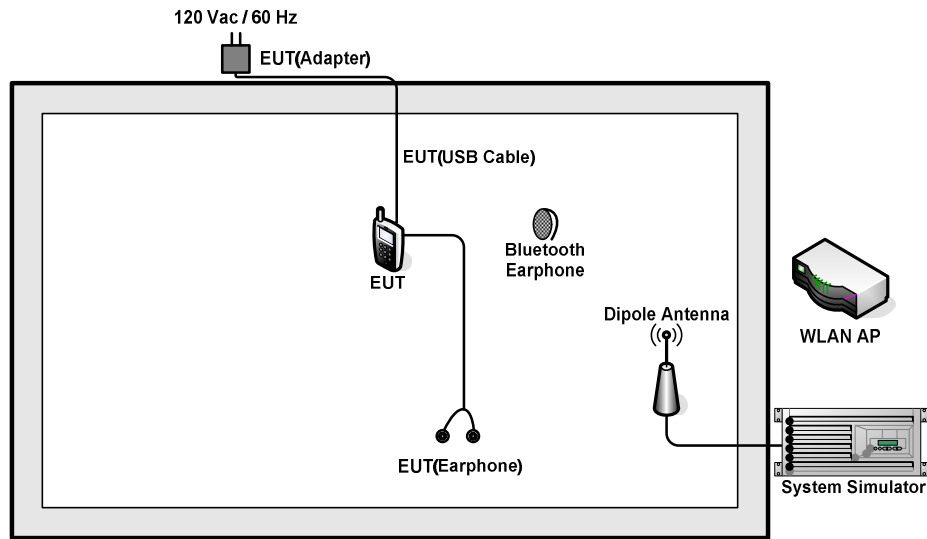

<Fig.1>

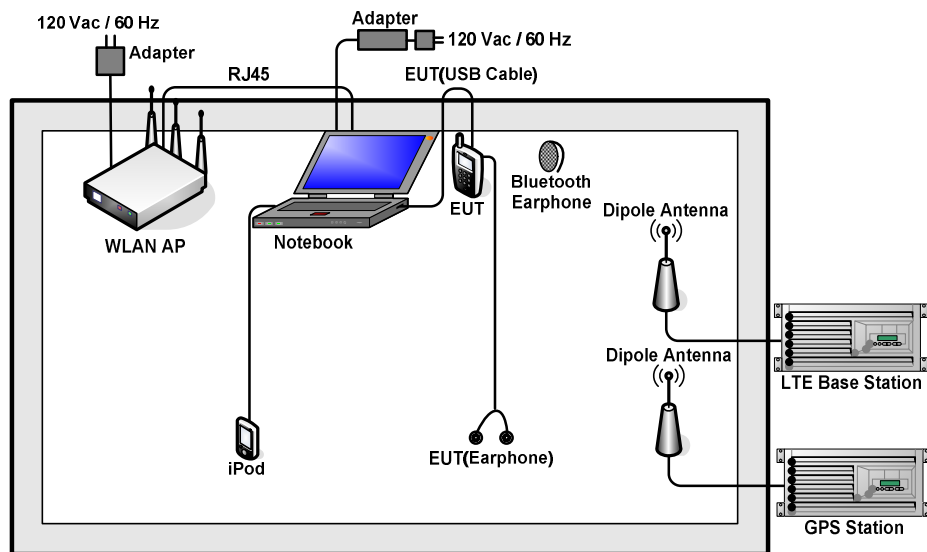

<Fig.2>



2.3. Support Unit used in test configuration and system

Item	Equipment	Trade Name	Model Name	FCC ID	Data Cable	Power Cord
1.	System Simulator	R&S	CMU 200	N/A	N/A	Unshielded, 1.8 m
2.	LTE Base Station	Anritsu	MT8820C	N/A	N/A	Unshielded, 1.8 m
3.	GPS Station	ADIVIC	MP9000	N/A	N/A	Unshielded, 1.8 m
4.	WLAN AP	D-Link	DIR-628	KA2DIR628A2	N/A	Unshielded, 1.8 m
5.	WLAN AP	ASUSTek	RT-AC66U	MSQ-RTAC66U	N/A	Unshielded, 2.7 m with Core
6.	Notebook	Lenovo	E540	FCC DoC	N/A	AC I/P: Unshielded, 1.2 m DC O/P: Shielded, 1.8 m
7.	Bluetooth Earphone	Nokia	BH-108	PYAHS-107W	N/A	N/A
8.	Bluetooth Earphone	Samsung	HS3000	A3LHS3000	N/A	N/A
9.	iPod nano 8GB	Apple	MC690ZP/A	FCC DoC	Shielded, 1.2 m	N/A
10.	iPod	Apple	MC525 ZP/A	FCC DoC	Shielded, 1.0 m	N/A
11.	SD Card	SanDisk	4G class 4	FCC DoC	N/A	N/A

2.4. EUT Operation Test Setup

The EUT was in GSM or WCDMA or LTE idle mode during the testing. The EUT was synchronized to the BCCH, and was in continuous receiving mode by setting system simulator’s paging reorganization.

At the same time, the EUT was attached to the Bluetooth earphone or WLAN AP, and the following programs installed in the EUT were programmed during the test.

1. Data application is transferred between notebook and EUT via USB cable.
2. Turn on GPS function to make the EUT receive continuous signals from GPS station.
3. Execute “Video Player” to play MPEG4 files.
4. Turn on camera to capture images.



3. Test Result

3.1. Test of AC Conducted Emission Measurement

3.1.1 Limits of AC Conducted Emission

For equipment that is designed to be connected to the public utility (AC) power line, the radio frequency voltage that is conducted back onto the AC power line on any frequency or frequencies within the band 150 kHz to 30 MHz shall not exceed the limits in the following table.

Frequency of emission (MHz)	Conducted limit (dBuV)	
	Quasi-peak	Average
0.15-0.5	66 to 56*	56 to 46*
0.5-5	56	46
5-30	60	50

*Decreases with the logarithm of the frequency.

3.1.2 Measuring Instruments

The measuring equipment is listed in the section 4 of this test report.

3.1.3 Test Procedure

1. The EUT was placed 0.4 meter from the conducting wall of the shielding room was kept at least 80 centimeters from any other grounded conducting surface.
2. Connect EUT to the power mains through a line impedance stabilization network (LISN).
3. All the support units are connecting to the other LISN.
4. The LISN provides 50 ohm coupling impedance for the measuring instrument.
5. The FCC states that a 50 ohm, 50 microhenry LISN should be used.
6. Both sides of AC line were checked for maximum conducted interference.
7. The frequency range from 150 kHz to 30 MHz was searched.
8. Set the test-receiver system to Peak Detect Function and specified bandwidth (IF Bandwidth = 9kHz) with Maximum Hold Mode. Then measurement is also conducted by Average Detector and Quasi-Peak Detector Function respectively.

3.1.4 Test Setup





3.1.5 Test Result of AC Conducted Emission

Test Mode :	Mode 2	Temperature :	21~23°C
Test Engineer :	Jacky Yang	Relative Humidity :	41~43%
Test Voltage :	120Vac / 60Hz	Phase :	Line
Function Type :	GSM850 Idle + Bluetooth Idle + WLAN Idle + USB Cable (Charging from Adapter) + Earphone + MPEG4 + SIM2		

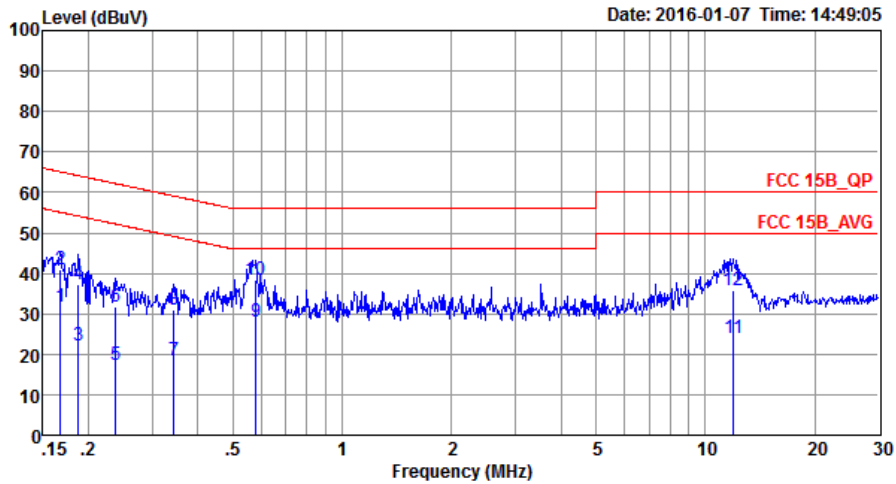

Condition: FCC 15B_QP LISN_L_20150304 LINE

Mode : Mode 2
IMEI : 354147042001165/354147042036161

	Freq	Level	Over Limit	Limit Line	Read Level	LISN Factor	Cable Loss	Remark
	MHz	dBuV	dB	dBuV	dBuV	dB	dB	
1	0.17	31.90	-23.18	55.08	21.10	0.47	10.33	Average
2	0.17	41.10	-23.98	65.08	30.30	0.47	10.33	QP
3	0.19	22.01	-32.14	54.15	11.20	0.50	10.31	Average
4	0.19	37.21	-26.94	64.15	26.40	0.50	10.31	QP
5	0.24	17.20	-34.97	52.17	6.41	0.54	10.25	Average
6	0.24	31.90	-30.27	62.17	21.11	0.54	10.25	QP
7	0.34	18.44	-30.65	49.09	7.69	0.56	10.19	Average
8	0.34	30.84	-28.25	59.09	20.09	0.56	10.19	QP
9	0.58	27.97	-18.03	46.00	17.21	0.61	10.15	Average
10 *	0.58	38.47	-17.53	56.00	27.71	0.61	10.15	QP
11	11.93	24.15	-25.85	50.00	13.10	0.64	10.41	Average
12	11.93	35.85	-24.15	60.00	24.80	0.64	10.41	QP



Test Mode :	Mode 2	Temperature :	21~23°C
Test Engineer :	Jacky Yang	Relative Humidity :	41~43%
Test Voltage :	120Vac / 60Hz	Phase :	Neutral
Function Type :	GSM850 Idle + Bluetooth Idle + WLAN Idle + USB Cable (Charging from Adapter) + Earphone + MPEG4 + SIM2		

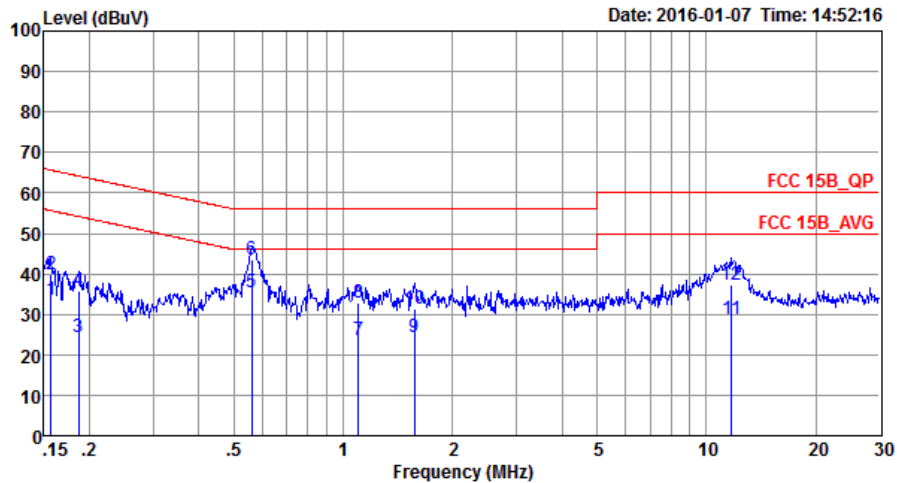

Condition: FCC 15B_QP LISN_N_20150304 NEUTRAL

Mode : Mode 2

IMEI : 354147042001165/354147042036161

	Freq	Level	Over Limit	Limit Line	Read Level	LISN Factor	Cable Loss	Remark
	MHz	dBuV	dB	dBuV	dBuV	dB	dB	
1	0.16	33.71	-21.94	55.65	22.90	0.46	10.35	Average
2	0.16	39.81	-25.84	65.65	29.00	0.46	10.35	QP
3	0.19	24.31	-29.89	54.20	13.50	0.50	10.31	Average
4	0.19	35.81	-28.39	64.20	25.00	0.50	10.31	QP
5 *	0.56	35.54	-10.46	46.00	24.80	0.59	10.15	Average
6	0.56	43.54	-12.46	56.00	32.80	0.59	10.15	QP
7	1.10	23.62	-22.38	46.00	12.90	0.56	10.16	Average
8	1.10	32.92	-23.08	56.00	22.20	0.56	10.16	QP
9	1.57	24.34	-21.66	46.00	13.59	0.57	10.18	Average
10	1.57	31.54	-24.46	56.00	20.79	0.57	10.18	QP
11	11.74	28.91	-21.09	50.00	17.81	0.70	10.40	Average
12	11.74	37.21	-22.79	60.00	26.11	0.70	10.40	QP



Test Mode :	Mode 3	Temperature :	21~23°C
Test Engineer :	Jacky Yang	Relative Humidity :	41~43%
Test Voltage :	120Vac / 60Hz	Phase :	Line
Function Type :	LTE Band 7 Idle + Bluetooth Idle + WLAN Idle + USB Cable (Data Link with Notebook) + Earphone + GPS Rx + SIM1		

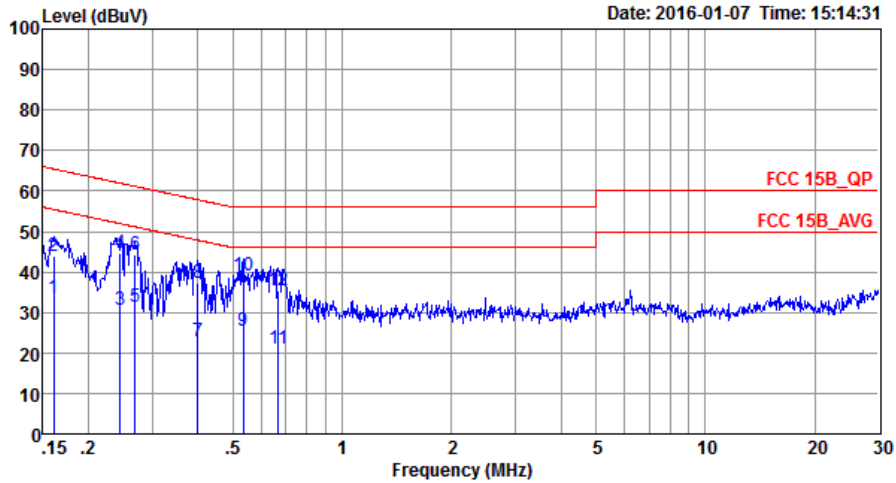

Condition: FCC 15B_QP LISN_L_20150304 LINE

Mode : Mode 3
IMEI : 354147042001165/354147042036161

	Freq	Level	Over Limit	Limit Line	Read Level	LISN Factor	Cable Loss	Remark
	MHz	dBuV	dB	dBuV	dBuV	dB	dB	
1	0.16	33.69	-21.74	55.43	22.90	0.45	10.34	Average
2	0.16	43.89	-21.54	65.43	33.10	0.45	10.34	QP
3	0.24	30.59	-21.36	51.95	19.79	0.55	10.25	Average
4	0.24	44.79	-17.16	61.95	33.99	0.55	10.25	QP
5	0.27	31.18	-19.98	51.16	20.39	0.56	10.23	Average
6	0.27	44.18	-16.98	61.16	33.39	0.56	10.23	QP
7	0.40	22.81	-25.05	47.86	12.10	0.54	10.17	Average
8	0.40	37.31	-20.55	57.86	26.60	0.54	10.17	QP
9	0.53	25.50	-20.50	46.00	14.71	0.64	10.15	Average
10 *	0.53	39.20	-16.80	56.00	28.41	0.64	10.15	QP
11	0.67	21.01	-24.99	46.00	10.30	0.56	10.15	Average
12	0.67	35.51	-20.49	56.00	24.80	0.56	10.15	QP



Test Mode :	Mode 3	Temperature :	21~23°C
Test Engineer :	Jacky Yang	Relative Humidity :	41~43%
Test Voltage :	120Vac / 60Hz	Phase :	Neutral
Function Type :	LTE Band 7 Idle + Bluetooth Idle + WLAN Idle + USB Cable (Data Link with Notebook) + Earphone + GPS Rx + SIM1		

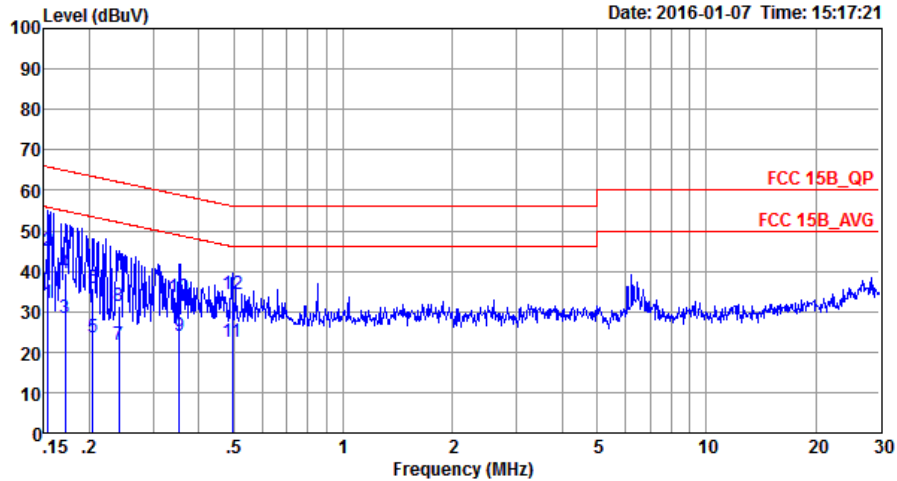

Condition: FCC 15B_QP LISN_N_20150304 NEUTRAL

Mode : Mode 3
IMEI : 354147042001165/354147042036161

	Freq	Level	Over Limit	Limit Line	Read Level	LISN Factor	Cable Loss	Remark
	MHz	dBuV	dB	dBuV	dBuV	dB	dB	
1	0.15	32.21	-23.57	55.78	21.40	0.46	10.35	Average
2 *	0.15	45.11	-20.67	65.78	34.30	0.46	10.35	QP
3	0.17	28.41	-26.49	54.90	17.60	0.48	10.33	Average
4	0.17	39.31	-25.59	64.90	28.50	0.48	10.33	QP
5	0.20	23.50	-29.95	53.45	12.70	0.51	10.29	Average
6	0.20	35.70	-27.75	63.45	24.90	0.51	10.29	QP
7	0.24	21.70	-30.34	52.04	10.90	0.55	10.25	Average
8	0.24	31.20	-30.84	62.04	20.40	0.55	10.25	QP
9	0.35	23.95	-24.92	48.87	13.20	0.57	10.18	Average
10	0.35	33.45	-25.42	58.87	22.70	0.57	10.18	QP
11	0.49	22.36	-23.74	46.10	11.59	0.61	10.16	Average
12	0.49	34.46	-21.64	56.10	23.69	0.61	10.16	QP



3.2. Test of Radiated Emission Measurement

3.2.1. Limit of Radiated Emission

The emissions from an unintentional radiator shall not exceed the field strength levels specified in the following table:

Frequency (MHz)	Field Strength (microvolts/meter)	Measurement Distance (meters)
30 – 88	100	3
88 – 216	150	3
216 - 960	200	3
Above 960	500	3

3.2.2. Measuring Instruments

The measuring equipment is listed in the section 4 of this test report.

3.2.3. Test Procedures

1. The EUT was placed on a turntable with 0.8 meter above ground.
2. The EUT was set 3 meters from the interference receiving antenna, which was mounted on the top of a variable height antenna tower.
3. The table was rotated 360 degrees to determine the position of the highest radiation.
4. The antenna height is adjusted between one to four meters above ground to find the maximum value of the field strength for both horizontal polarization and vertical polarization of the antenna.
5. For each suspected emission, the EUT was arranged to its worst case and then tune the antenna tower (from 1 m to 4 m) and turntable (from 0 degree to 360 degrees) to find the maximum reading.
6. Set the test-receiver system to Peak Detect Function and specified bandwidth with Maximum Hold Mode (RBW=120kHz/VBW=300kHz for frequency below 1GHz; RBW=1MHz VBW=3MHz (Peak), RBW=1MHz/VBW=10Hz (Average) for frequency above 1GHz).
7. If the emission level of the EUT in peak mode was 3 dB lower than the limit specified, peak values of EUT will be reported. Otherwise, the emission will be repeated by using the quasi-peak method and reported.
8. Emission level (dBµV/m) = 20 log Emission level (µV/m)
9. Corrected Reading: Antenna Factor + Cable Loss + Read Level - Preamp Factor = Level

3.2.4. Test Setup of Radiated Emission

For radiated emissions from 30MHz to 1GHz

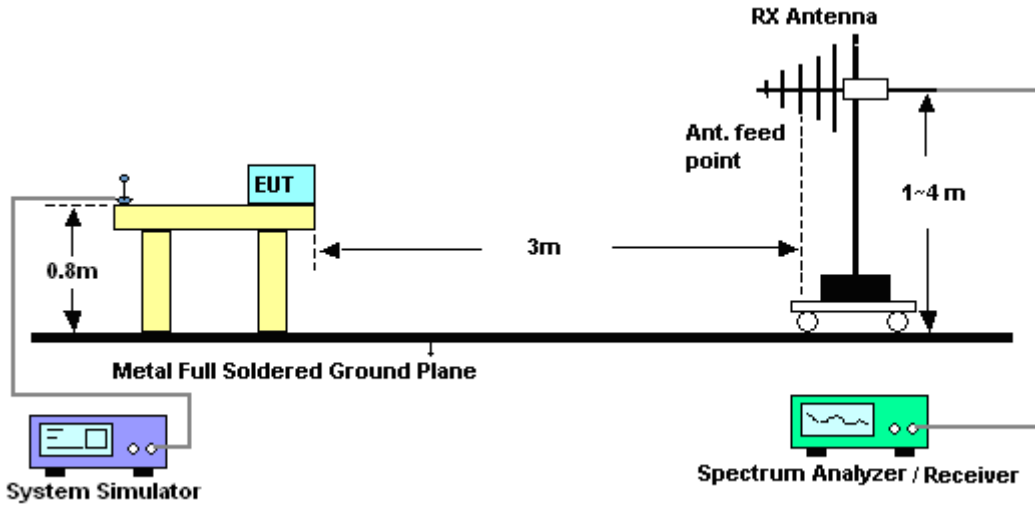

For radiated emissions above 1GHz

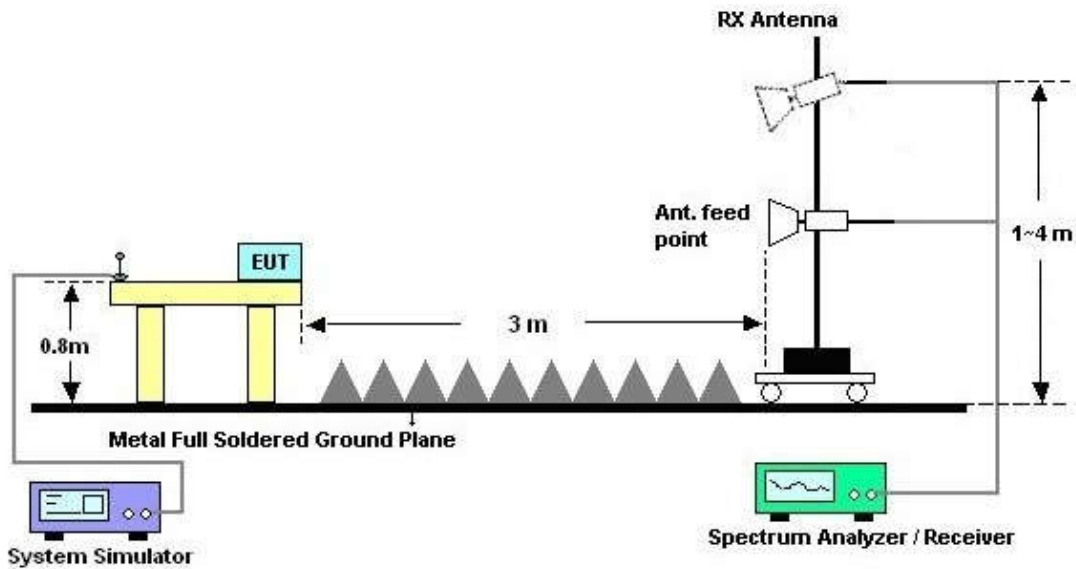



3.2.5. Test Result of Radiated Emission

Test Mode :	Mode 2	Temperature :	23~25°C
Test Engineer :	Jeff Yao	Relative Humidity :	48~52%
Test Distance :	3m	Polarization :	Horizontal
Function Type :	GSM850 Idle + Bluetooth Idle + WLAN Idle + USB Cable (Charging from Adapter) + Earphone + MPEG4 + SIM2		
Remark :	#7 is system simulator signal which can be ignored.		

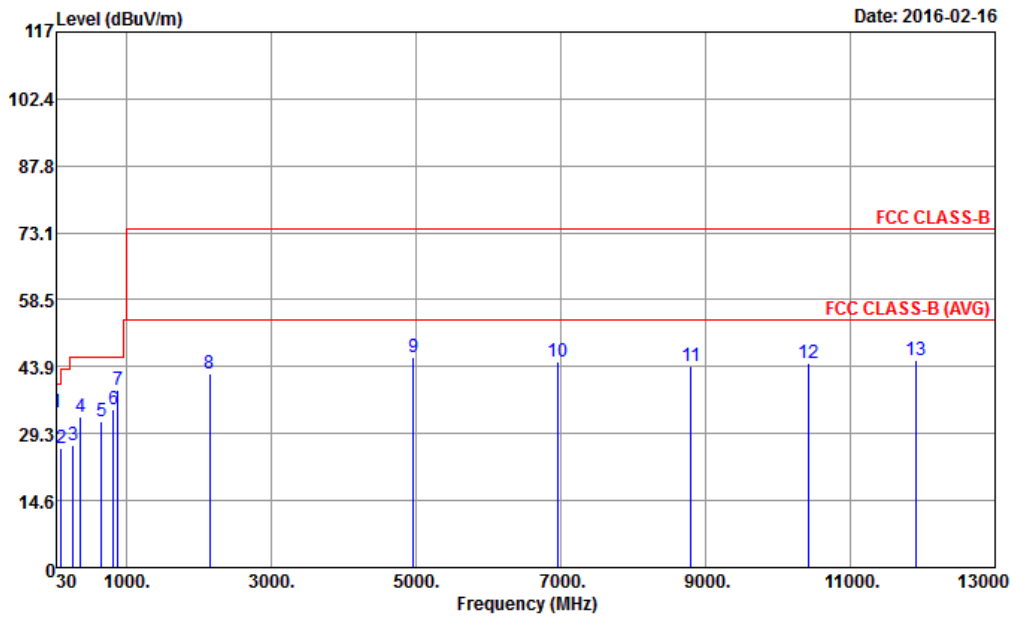

Site : 03CH03-KS
 Condition : FCC CLASS-B 3m LF_ANT(23188)6_15101 HORIZONTAL

Mode : Mode 2
 IMEI : 354147042001165/354147042036161

	Freq	Level	Over Limit	Limit Line	ReadAntenna Level	Cable Factor	Preamp Loss	A/Pos	T/Pos	Remark	
	MHz	dBuV/m	dB	dBuV/m	dBuV	dB/m	dB	cm	deg		
1	30.00	34.06	-5.94	40.00	27.78	31.60	0.75	26.07	100	0 Peak	
2	98.58	26.01	-17.49	43.50	33.07	17.58	1.14	25.78	---	---	Peak
3	261.39	26.84	-19.16	46.00	31.59	18.80	1.57	25.12	---	---	Peak
4	366.50	32.90	-13.10	46.00	35.54	20.97	1.95	25.56	---	---	Peak
5	654.20	32.00	-14.00	46.00	29.76	26.03	2.61	26.40	---	---	Peak
6	815.90	34.60	-11.40	46.00	29.41	28.36	2.95	26.12	---	---	Peak
7	881.70	38.83			33.97	27.77	3.02	25.93	---	---	Peak
8	2152.00	42.24	-31.76	74.00	63.76	32.36	4.80	58.68	---	---	Peak
9	4960.00	45.83	-28.17	74.00	62.09	34.48	7.56	58.30	100	0 Peak	
10	6956.00	44.90	-29.10	74.00	57.01	36.12	9.26	57.49	---	---	Peak
11	8802.00	44.12	-29.88	74.00	54.52	36.56	10.90	57.86	---	---	Peak
12	10422.00	44.54	-29.46	74.00	52.86	38.43	12.26	59.01	---	---	Peak
13	11902.00	45.21	-28.79	74.00	53.31	39.44	12.62	60.16	---	---	Peak



Test Mode :	Mode 2	Temperature :	23~25°C
Test Engineer :	Jeff Yao	Relative Humidity :	48~52%
Test Distance :	3m	Polarization :	Vertical
Function Type :	GSM850 Idle + Bluetooth Idle + WLAN Idle + USB Cable (Charging from Adapter) + Earphone + MPEG4 + SIM2		
Remark :	#6 is system simulator signal which can be ignored.		

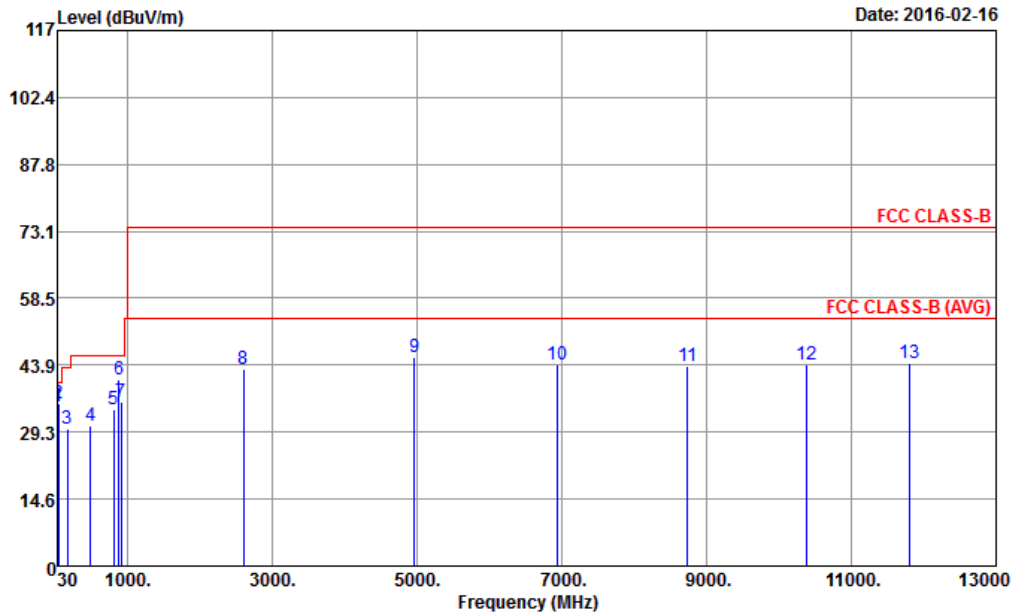

Site : 03CH03-KS
 Condition : FCC CLASS-B 3m LF_ANT(23188)6_15101 VERTICAL
 Mode : Mode 2
 IMEI : 354147042001165/354147042036161

	Freq	Level	Over	Limit	ReadAntenna	Cable	Preamp	A/Pos	T/Pos	Remark	
	MHz	dBuV/m	dB	dBuV/m	dBuV	dB/m	dB	dB	cm	deg	
1	30.00	34.98	-5.02	40.00	28.70	31.60	0.75	26.07	---	---	Peak
2	49.71	35.65	-4.35	40.00	43.56	17.32	0.75	25.98	120	30	QP
3	170.67	29.94	-13.56	43.50	36.01	17.83	1.50	25.40	---	---	Peak
4	489.70	30.77	-15.23	46.00	29.90	24.98	2.17	26.28	---	---	Peak
5	805.40	34.19	-11.81	46.00	29.01	28.46	2.88	26.16	---	---	Peak
6	881.70	40.59			35.73	27.77	3.02	25.93	---	---	Peak
7	912.50	35.69	-10.31	46.00	30.83	27.55	3.08	25.77	---	---	Peak
8	2598.00	43.06	-30.94	74.00	63.80	32.78	5.31	58.83	---	---	Peak
9	4960.00	45.78	-28.22	74.00	62.04	34.48	7.56	58.30	100	0	Peak
10	6932.00	44.06	-29.94	74.00	56.31	36.13	9.26	57.64	---	---	Peak
11	8736.00	43.61	-30.39	74.00	53.95	36.48	10.93	57.75	---	---	Peak
12	10380.00	44.12	-29.88	74.00	52.49	38.41	12.23	59.01	---	---	Peak
13	11802.00	44.23	-29.77	74.00	52.29	39.38	12.61	60.05	---	---	Peak



Test Mode :	Mode 3	Temperature :	23~25°C
Test Engineer :	Jeff Yao	Relative Humidity :	48~52%
Test Distance :	3m	Polarization :	Horizontal
Function Type :	LTE Band 7 Idle + Bluetooth Idle + WLAN Idle + USB Cable (Data Link with Notebook) + Earphone + GPS Rx + SIM1		
Remark :	#8 is system simulator signal which can be ignored.		

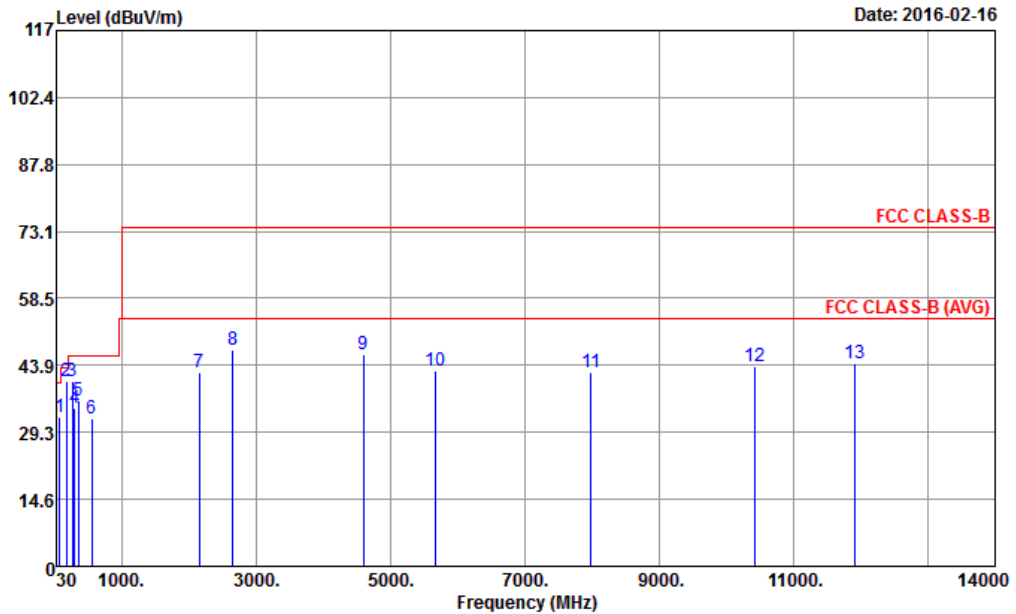

Site : 03CH03-KS
 Condition : FCC CLASS-B 3m LF_ANT(23188)6_15101 HORIZONTAL

Mode : Mode 3
 IMEI : 354147042001165/354147042036161

	Freq	Level	Over	Limit	ReadAntenna	Cable	Preamp	A/Pos	T/Pos	Remark	
	MHz	dBuV/m	dB	dBuV/m	dBuV	dB/m	dB	dB	cm	deg	
1	85.35	32.47	-7.53	40.00	40.98	16.35	0.98	25.84	---	---	Peak
2	176.34	40.27	-3.23	43.50	46.51	17.63	1.50	25.37	100	0	Peak
3	270.84	40.56	-5.44	46.00	44.99	19.10	1.57	25.10	---	---	Peak
4	300.00	34.64	-11.36	46.00	37.87	20.10	1.71	25.04	---	---	Peak
5	360.90	36.09	-9.91	46.00	38.75	20.90	1.95	25.51	---	---	Peak
6	555.50	32.38	-13.62	46.00	30.86	25.57	2.35	26.40	---	---	Peak
7	2152.00	42.24	-31.76	74.00	63.76	32.36	4.80	58.68	---	---	Peak
8	2656.00	47.33			68.04	32.82	5.41	58.94	---	---	Peak
9	4602.00	46.19	-27.81	74.00	64.14	34.26	7.26	59.47	100	0	Peak
10	5662.00	42.83	-31.17	74.00	58.38	35.32	8.15	59.02	---	---	Peak
11	7982.00	42.51	-31.49	74.00	52.89	36.49	11.09	57.96	---	---	Peak
12	10422.00	43.54	-30.46	74.00	51.86	38.43	12.26	59.01	---	---	Peak
13	11902.00	44.21	-29.79	74.00	52.31	39.44	12.62	60.16	---	---	Peak



Test Mode :	Mode 3	Temperature :	23~25°C
Test Engineer :	Jeff Yao	Relative Humidity :	48~52%
Test Distance :	3m	Polarization :	Vertical
Function Type :	LTE Band 7 Idle + Bluetooth Idle + WLAN Idle + USB Cable (Data Link with Notebook) + Earphone + GPS Rx + SIM1		
Remark :	#8 is system simulator signal which can be ignored.		

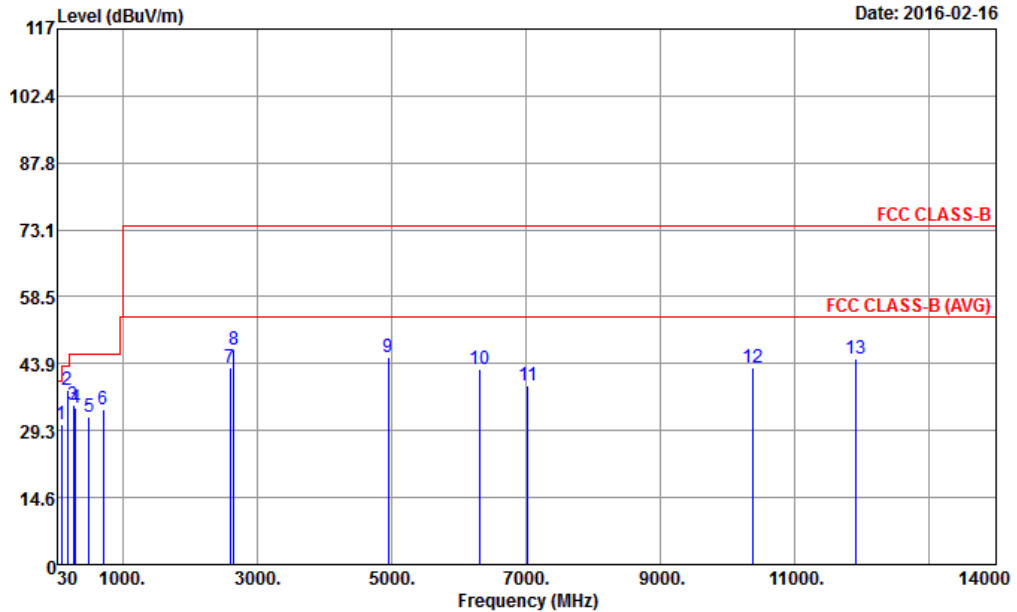

Site : 03CH03-KS
 Condition : FCC CLASS-B 3m LF_ANT(23188)6_15101 VERTICAL

Mode : Mode 3
 IMEI : 354147042001165/354147042036161

	Freq	Level	Over	Limit	ReadAntenna	Cable	Preamp	A/Pos	T/Pos	Remark	
	MHz	dBuV/m	dB	dBuV/m	dBuV	dB/m	dB	dB	cm	deg	
1	86.16	30.66	-9.34	40.00	39.13	16.38	0.98	25.83	---	---	Peak
2	175.26	37.99	-5.51	43.50	44.20	17.67	1.50	25.38	100	0	Peak
3	270.30	34.77	-11.23	46.00	39.20	19.10	1.57	25.10	---	---	Peak
4	300.00	34.18	-11.82	46.00	37.41	20.10	1.71	25.04	---	---	Peak
5	498.80	32.13	-13.87	46.00	30.97	25.32	2.17	26.33	---	---	Peak
6	715.10	33.80	-12.20	46.00	30.87	26.62	2.65	26.34	---	---	Peak
7	2598.00	43.06	-30.94	74.00	63.80	32.78	5.31	58.83	---	---	Peak
8	2656.00	46.81			67.52	32.82	5.41	58.94	---	---	Peak
9	4950.00	45.17	-28.83	74.00	61.55	34.47	7.56	58.41	100	0	Peak
10	6314.00	42.85	-31.15	74.00	56.99	36.12	8.63	58.89	---	---	Peak
11	7036.00	39.07	-34.93	74.00	50.94	36.11	9.35	57.33	---	---	Peak
12	10380.00	43.12	-30.88	74.00	51.49	38.41	12.23	59.01	---	---	Peak
13	11904.00	45.00	-29.00	74.00	53.10	39.44	12.62	60.16	---	---	Peak



4. List of Measuring Equipment

Instrument	Manufacturer	Model No.	Serial No.	Characteristics	Calibration Date	Test Date	Due Date	Remark
EMI Receiver	R&S	ESC17	100768	9kHz~7GHz;	May 04, 2015	Jan. 07, 2016	May 03, 2016	Conduction (CO01-KS)
AC LISN	MessTec	AN3016	060103	9kHz~30MHz	Oct. 24, 2015	Jan. 07, 2016	Oct. 23, 2016	Conduction (CO01-KS)
AC LISN (for auxiliary equipment)	MessTec	AN3016	060105	9kHz~30MHz	Oct. 24, 2015	Jan. 07, 2016	Oct. 23, 2016	Conduction (CO01-KS)
AC Power Source	Chroma	61602	ABP0000008 11	AC 0V~300V, 45Hz~1000Hz	Oct. 24, 2015	Jan. 07, 2016	Oct. 23, 2016	Conduction (CO01-KS)
EMI Test Receiver	R&S	ESR7	101403	9kHz~7GHz; Max 30dBm	Sep. 10, 2015	Feb. 16, 2016	Sep. 09, 2016	Radiation (03CH03-KS)
EXA Spectrum Analyzer	Keysight	N9010A	MY55150244	10Hz~44GHz	Jun. 05, 2015	Feb. 16, 2016	Jun. 04, 2016	Radiation (03CH03-KS)
Bilog Antenna	TeseQ	CBL6112D	23182	25MHz~2GHz	Jan. 16, 2016	Feb. 16, 2016	Jan. 15, 2017	Radiation (03CH03-KS)
Horn Antenna	Schwarzbeck	BBHA9120D	9120D-1356	1GHz~18GHz	Jun. 25, 2015	Feb. 16, 2016	Jun. 24, 2016	Radiation (03CH03-KS)
Amplifier	MITEQ	TTA1840-35-H G	1887435	18~40GHz	Aug. 27, 2015	Feb. 16, 2016	Aug. 26, 2016	Radiation (03CH03-KS)
Amplifier	Burgeon	BPA-530	102212	0.01MHz~3000 MHz	Aug.10, 2015	Feb. 16, 2016	Aug. 09, 2016	Radiation (03CH03-KS)
Amplifier	Agilent	8449B	3008A02370	1GHz~26.5GHz	Oct. 24, 2015	Feb. 16, 2016	Oct. 23, 2016	Radiation (03CH03-KS)
AC Power Source	Chroma	61601	F104090004	N/A	NCR	Feb. 16, 2016	NCR	Radiation (03CH03-KS)
Turn Table	ChamPro	EM 1000-T	060762-T	0~360 degree	NCR	Feb. 16, 2016	NCR	Radiation (03CH03-KS)
Antenna Mast	ChamPro	EM 1000-A	060762-A	1 m~4 m	NCR	Feb. 16, 2016	NCR	Radiation (03CH03-KS)

NCR: No Calibration Required



5. Uncertainty of Evaluation

Uncertainty of Conducted Emission Measurement (150 kHz ~ 30 MHz)

Measuring Uncertainty for a Level of Confidence of 95% ($U = 2Uc(y)$)	2.4dB
---	-------

Uncertainty of Radiated Emission Measurement (30 MHz ~ 1000 MHz)

Measuring Uncertainty for a Level of Confidence of 95% ($U = 2Uc(y)$)	4.5dB
---	-------