

P01_GSM 850_GPRS10_Right Cheek_128

DUT: EUT

Communication System: GPRS 850-2solt; Frequency: 824.2 MHz;Duty Cycle: 1:4

Medium: H850 Medium parameters used (interpolated): $f = 824.2$ MHz; $\sigma = 0.915$ mho/m; $\epsilon_r = 43$; $\rho = 1000$ kg/m³

DASY4 Configuration:

- Probe: ES3DV3 - SN3090; ConvF(6.12, 6.12, 6.12); Calibrated: 2019/4/12
- Sensor-Surface: 3mm (Mechanical Surface Detection)
- Electronics: DAE4 Sn662; Calibrated: 2019/4/11
- Phantom: SAM 1; Type: QD 000 P40 CB; Serial: TP/1378
- ; Postprocessing SW: SEMCAD, V1.8 Build 186

Test/Area Scan (71x81x1): Measurement grid: dx=15mm, dy=15mm
 Maximum value of SAR (interpolated) = 0.156 mW/g

Test/Zoom Scan (5x5x7)/Cube 0: Measurement grid: dx=8mm, dy=8mm, dz=5mm
 Reference Value = 4.51 V/m; Power Drift = 0.13 dB
 Peak SAR (extrapolated) = 0.174 W/kg
SAR(1 g) = 0.139 mW/g; SAR(10 g) = 0.105 mW/g
 Maximum value of SAR (measured) = 0.149 mW/g

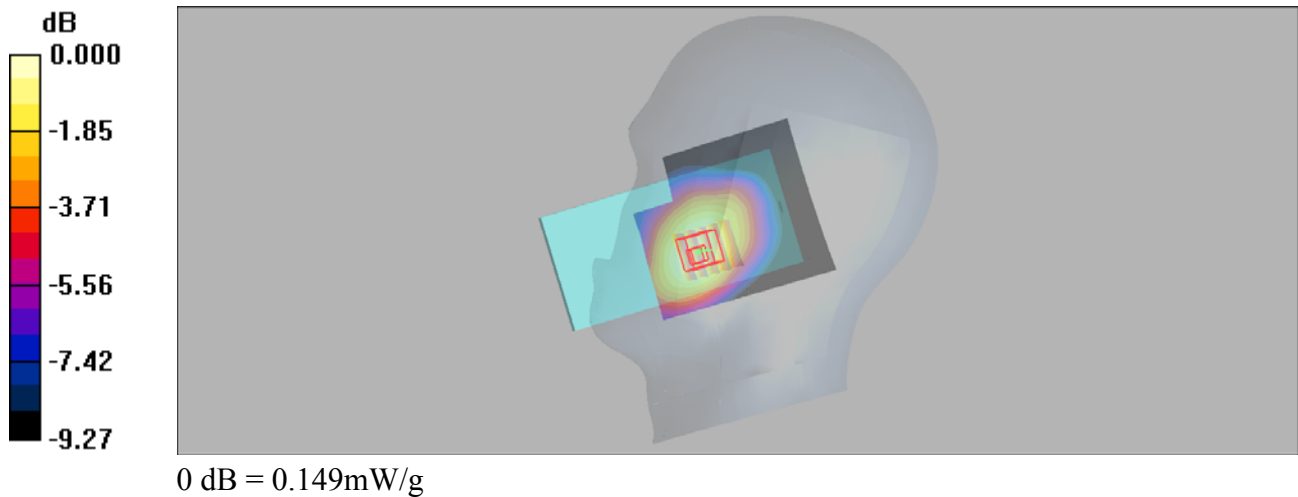

P02_GSM 1900_GPRS12_Left Cheek_810

DUT: EUT

Communication System: GPRS1900-4slots; Frequency: 1909.8 MHz; Duty Cycle: 1:2
Medium: H1900 Medium parameters used: $f = 1910$ MHz; $\sigma = 1.45$ mho/m; $\epsilon_r = 40.6$; $\rho = 1000$ kg/m³

DASY4 Configuration:

- Probe: ES3DV3 - SN3090; ConvF(5.06, 5.06, 5.06); Calibrated: 2019/4/12
- Sensor-Surface: 3mm (Mechanical Surface Detection)
- Electronics: DAE4 Sn662; Calibrated: 2019/4/11
- Phantom: SAM 2; Type: QD 000 P40 CB; Serial: TP-1376
- ; Postprocessing SW: SEMCAD, V1.8 Build 186

Test/Area Scan (71x81x1): Measurement grid: dx=15mm, dy=15mm
Maximum value of SAR (interpolated) = 0.789 mW/g

Test/Zoom Scan (5x5x7)/Cube 0: Measurement grid: dx=8mm, dy=8mm, dz=5mm
Reference Value = 7.74 V/m; Power Drift = -0.09 dB
Peak SAR (extrapolated) = 1.03 W/kg
SAR(1 g) = 0.662 mW/g; SAR(10 g) = 0.400 mW/g
Maximum value of SAR (measured) = 0.781 mW/g

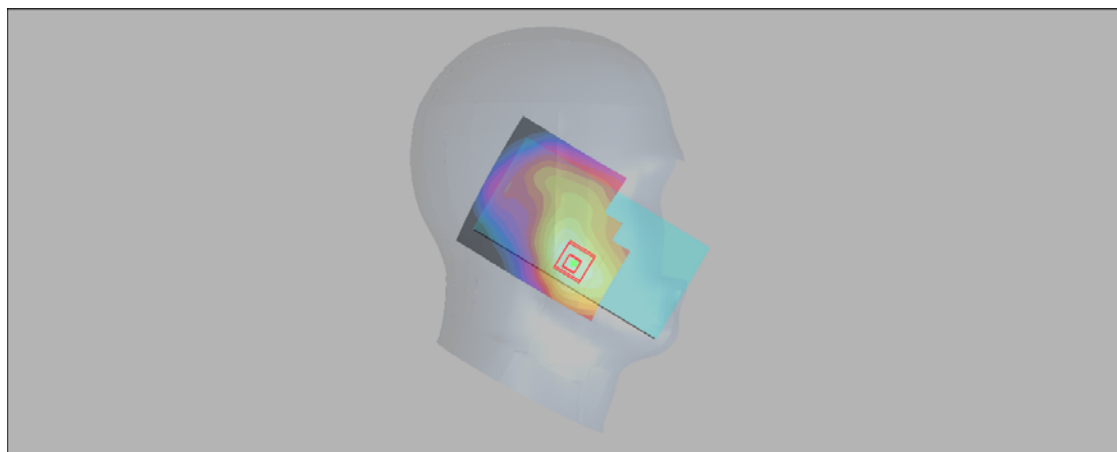
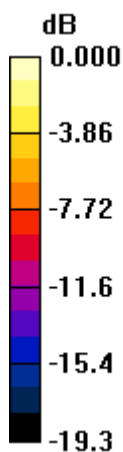

0 dB = 0.781mW/g

P03_WCDMA II_RMC12.2K_Left Cheek_9538

DUT: EUT

Communication System: WCDMA Band II; Frequency: 1907.6 MHz; Duty Cycle: 1:1
 Medium: H1900 Medium parameters used: $f = 1908 \text{ MHz}$; $\sigma = 1.45 \text{ mho/m}$; $\epsilon_r = 40.6$; $\rho = 1000 \text{ kg/m}^3$

DASY4 Configuration:

- Probe: ES3DV3 - SN3090; ConvF(5.06, 5.06, 5.06); Calibrated: 2019/4/12
- Sensor-Surface: 3mm (Mechanical Surface Detection)
- Electronics: DAE4 Sn662; Calibrated: 2019/4/11
- Phantom: SAM 2; Type: QD 000 P40 CB; Serial: TP-1376
- ; Postprocessing SW: SEMCAD, V1.8 Build 186

Test/Area Scan (71x81x1): Measurement grid: $dx=15\text{mm}$, $dy=15\text{mm}$
 Maximum value of SAR (interpolated) = 0.720 mW/g

Test/Zoom Scan (5x5x7)/Cube 0: Measurement grid: $dx=8\text{mm}$, $dy=8\text{mm}$, $dz=5\text{mm}$
 Reference Value = 7.61 V/m ; Power Drift = 0.02 dB
 Peak SAR (extrapolated) = 0.934 W/kg
SAR(1 g) = 0.596 mW/g ; SAR(10 g) = 0.361 mW/g
 Maximum value of SAR (measured) = 0.715 mW/g

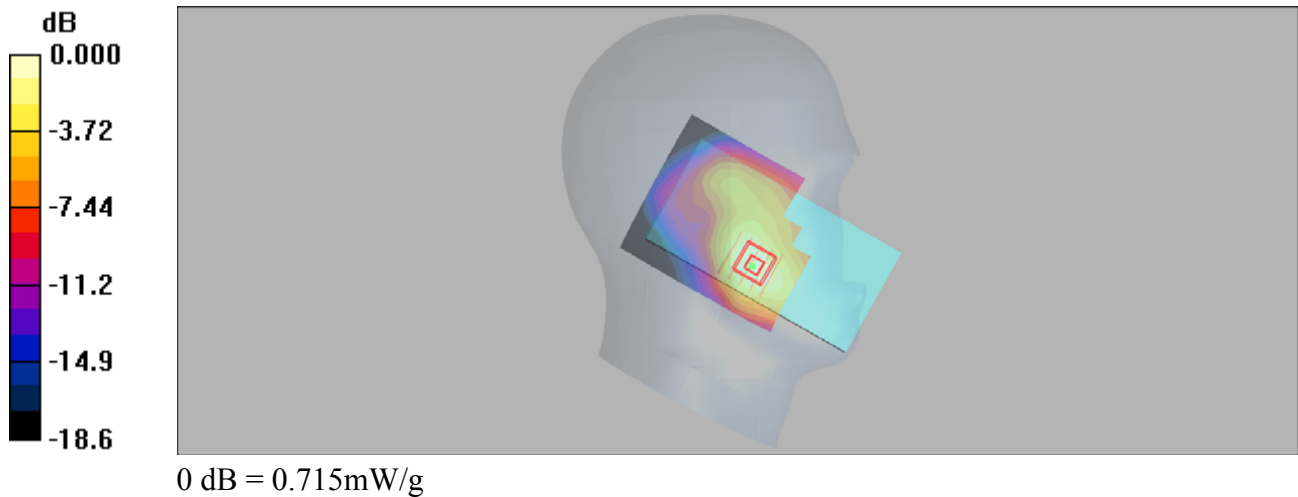

P04_WCDMA IV_RMC12.2K_Left Cheek_1513

DUT: EUT

Communication System: WCDMA Band IV; Frequency: 1752.6 MHz; Duty Cycle: 1:1
Medium: H1800 Medium parameters used: $f = 1753$ MHz; $\sigma = 1.37$ mho/m; $\epsilon_r = 40.3$; $\rho = 1000$ kg/m³

DASY4 Configuration:

- Probe: ES3DV3 - SN3090; ConvF(5.36, 5.36, 5.36); Calibrated: 2019/4/12
- Sensor-Surface: 3mm (Mechanical Surface Detection)
- Electronics: DAE4 Sn662; Calibrated: 2019/4/11
- Phantom: SAM 2; Type: QD 000 P40 CB; Serial: TP-1376
- ; Postprocessing SW: SEMCAD, V1.8 Build 186

Test/Area Scan (71x81x1): Measurement grid: dx=15mm, dy=15mm
Maximum value of SAR (interpolated) = 0.518 mW/g

Test/Zoom Scan (5x5x7)/Cube 0: Measurement grid: dx=8mm, dy=8mm, dz=5mm
Reference Value = 5.21 V/m; Power Drift = 0.02 dB
Peak SAR (extrapolated) = 0.627 W/kg
SAR(1 g) = 0.417 mW/g; SAR(10 g) = 0.261 mW/g
Maximum value of SAR (measured) = 0.488 mW/g

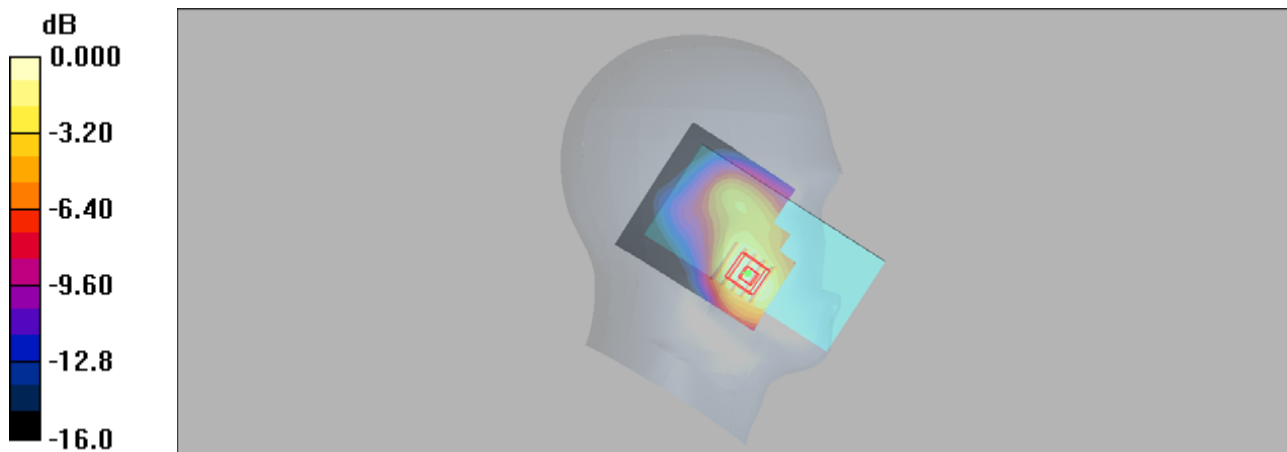

P05_WCDMA V_RMC12.2K_Right Cheek_4132

DUT: EUT

Communication System: WCDMA Band V; Frequency: 826.4 MHz; Duty Cycle: 1:1

Medium: H850 Medium parameters used (interpolated): $f = 826.4$ MHz; $\sigma = 0.917$ mho/m; $\epsilon_r = 43$; $\rho = 1000$ kg/m³

DASY4 Configuration:

- Probe: ES3DV3 - SN3090; ConvF(6.12, 6.12, 6.12); Calibrated: 2019/4/12
- Sensor-Surface: 3mm (Mechanical Surface Detection)
- Electronics: DAE4 Sn662; Calibrated: 2019/4/11
- Phantom: SAM 1; Type: QD 000 P40 CB; Serial: TP/1378
- ; Postprocessing SW: SEMCAD, V1.8 Build 186

Test/Area Scan (71x81x1): Measurement grid: dx=15mm, dy=15mm
 Maximum value of SAR (interpolated) = 0.305 mW/g

Test/Zoom Scan (5x5x7)/Cube 0: Measurement grid: dx=8mm, dy=8mm, dz=5mm
 Reference Value = 5.73 V/m; Power Drift = 0.052 dB
 Peak SAR (extrapolated) = 0.336 W/kg
SAR(1 g) = 0.271 mW/g; SAR(10 g) = 0.210 mW/g
 Maximum value of SAR (measured) = 0.295 mW/g

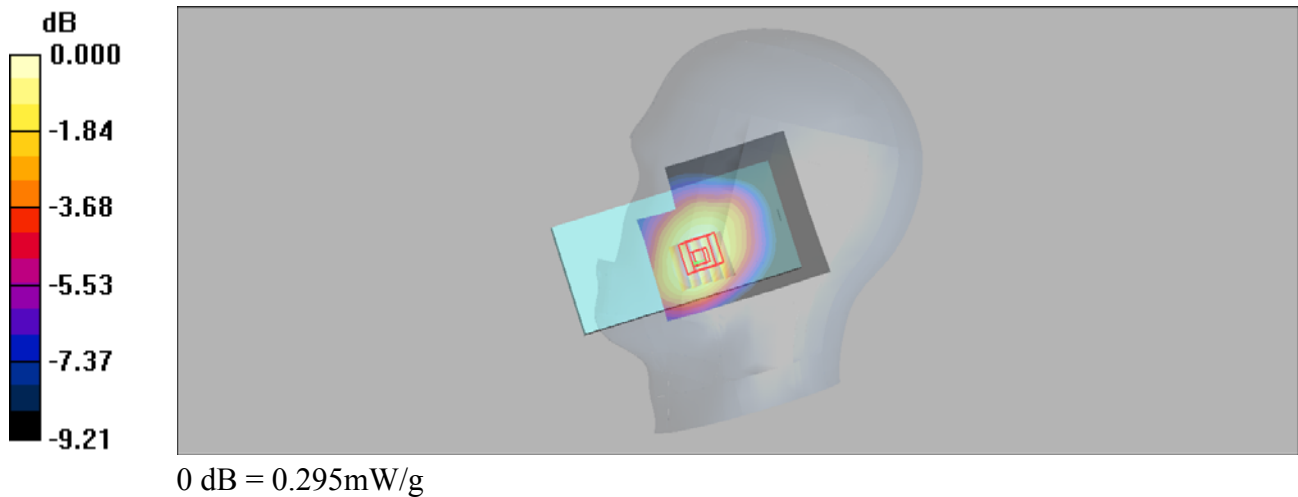

P06_LTE 2_QPSK20M_Left Cheek_18700_1 RB_0_Offset

DUT: EUT

Communication System: LTE Band 2; Frequency: 1860 MHz; Duty Cycle: 1:1

Medium: H1900 Medium parameters used: $f = 1860 \text{ MHz}$; $\sigma = 1.4 \text{ mho/m}$; $\epsilon_r = 40.8$; $\rho = 1000 \text{ kg/m}^3$

DASY4 Configuration:

- Probe: ES3DV3 - SN3090; ConvF(5.06, 5.06, 5.06); Calibrated: 2019/4/12
- Sensor-Surface: 3mm (Mechanical Surface Detection)
- Electronics: DAE4 Sn662; Calibrated: 2019/4/11
- Phantom: SAM 2; Type: QD 000 P40 CB; Serial: TP-1376
- ; Postprocessing SW: SEMCAD, V1.8 Build 186

Test/Area Scan (71x81x1): Measurement grid: $dx=15\text{mm}$, $dy=15\text{mm}$

Maximum value of SAR (interpolated) = 0.741 mW/g

Test/Zoom Scan (5x5x7)/Cube 0: Measurement grid: $dx=8\text{mm}$, $dy=8\text{mm}$, $dz=5\text{mm}$

Reference Value = 7.55 V/m; Power Drift = -0.08 dB

Peak SAR (extrapolated) = 0.917 W/kg

SAR(1 g) = 0.592 mW/g; SAR(10 g) = 0.362 mW/g

Maximum value of SAR (measured) = 0.695 mW/g

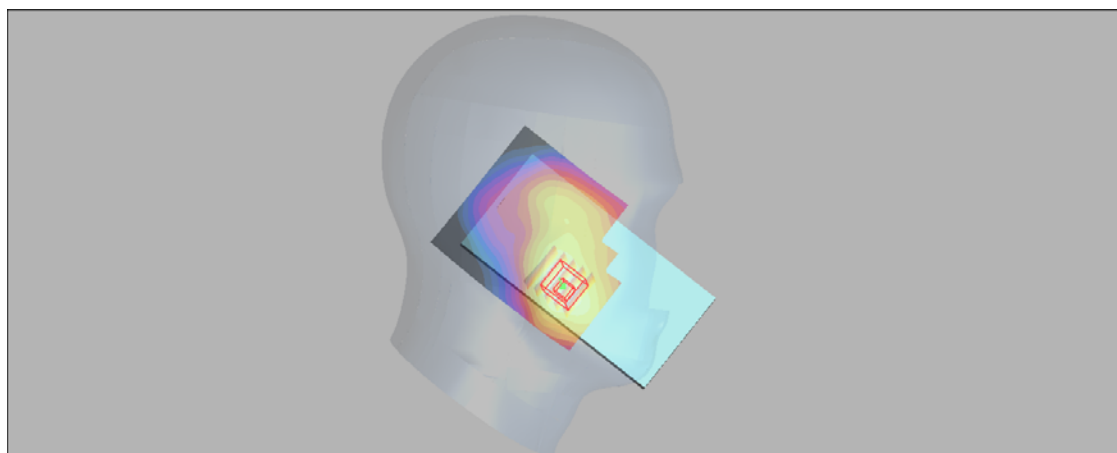
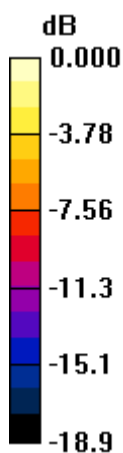

0 dB = 0.695mW/g

P07_LTE 4_QPSK20M_Left Cheek_20050_1 RB_50_Offset

DUT: EUT

Communication System: LTE Band 4&20M; Frequency: 1720 MHz;Duty Cycle: 1:1
Medium: H1800 Medium parameters used: $f = 1720$ MHz; $\sigma = 1.34$ mho/m; $\epsilon_r = 40.5$; $\rho = 1000$ kg/m³

DASY4 Configuration:

- Probe: ES3DV3 - SN3090; ConvF(5.36, 5.36, 5.36); Calibrated: 2019/4/12
- Sensor-Surface: 3mm (Mechanical Surface Detection)
- Electronics: DAE4 Sn662; Calibrated: 2019/4/11
- Phantom: SAM 2; Type: QD 000 P40 CB; Serial: TP-1376
- ; Postprocessing SW: SEMCAD, V1.8 Build 186

Test/Area Scan (71x81x1): Measurement grid: dx=15mm, dy=15mm
Maximum value of SAR (interpolated) = 0.450 mW/g

Test/Zoom Scan (5x5x7)/Cube 0: Measurement grid: dx=8mm, dy=8mm, dz=5mm
Reference Value = 4.90 V/m; Power Drift = 0.04 dB
Peak SAR (extrapolated) = 0.556 W/kg
SAR(1 g) = 0.375 mW/g; SAR(10 g) = 0.237 mW/g
Maximum value of SAR (measured) = 0.446 mW/g

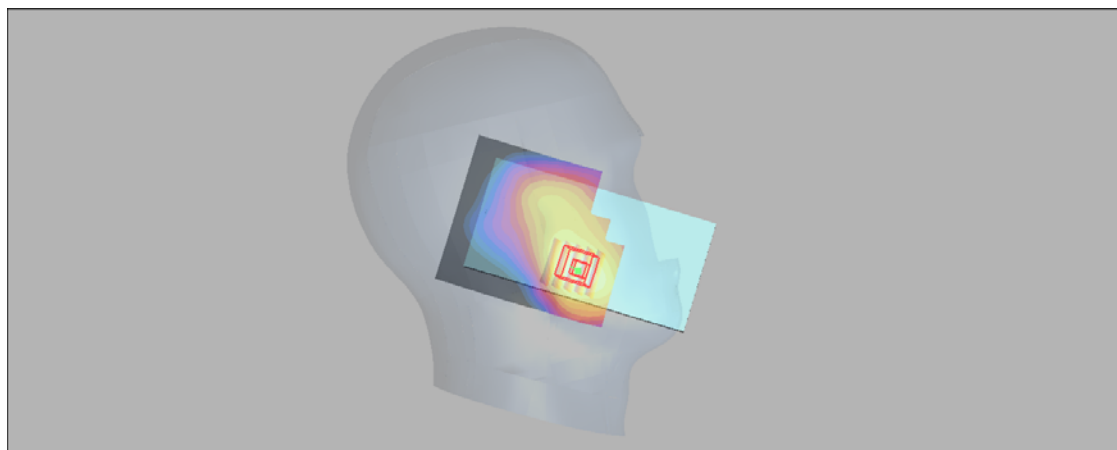
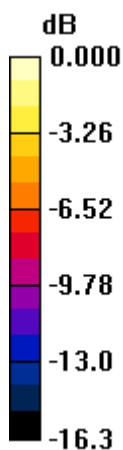

0 dB = 0.446mW/g

P08_LTE 5_QPSK20M_Left Tilted_20525_1 RB_24_Offset

DUT: EUT

Communication System: LTE Band5; Frequency: 836.5 MHz;Duty Cycle: 1:1

Medium: H850 Medium parameters used (interpolated): $f = 836.5$ MHz; $\sigma = 0.927$ mho/m; $\epsilon_r = 42.8$;

$\rho = 1000$ kg/m³

DASY4 Configuration:

- Probe: ES3DV3 - SN3090; ConvF(6.12, 6.12, 6.12); Calibrated: 2019/4/12
- Sensor-Surface: 3mm (Mechanical Surface Detection)
- Electronics: DAE4 Sn662; Calibrated: 2019/4/11
- Phantom: SAM 1; Type: QD 000 P40 CB; Serial: TP/1378
- ; Postprocessing SW: SEMCAD, V1.8 Build 186

Test/Area Scan (71x81x1): Measurement grid: dx=15mm, dy=15mm

Maximum value of SAR (interpolated) = 0.163 mW/g

Test/Zoom Scan (5x5x7)/Cube 0: Measurement grid: dx=8mm, dy=8mm, dz=5mm

Reference Value = 7.80 V/m; Power Drift = -0.016 dB

Peak SAR (extrapolated) = 0.175 W/kg

SAR(1 g) = 0.152 mW/g; SAR(10 g) = 0.120 mW/g

Maximum value of SAR (measured) = 0.161 mW/g

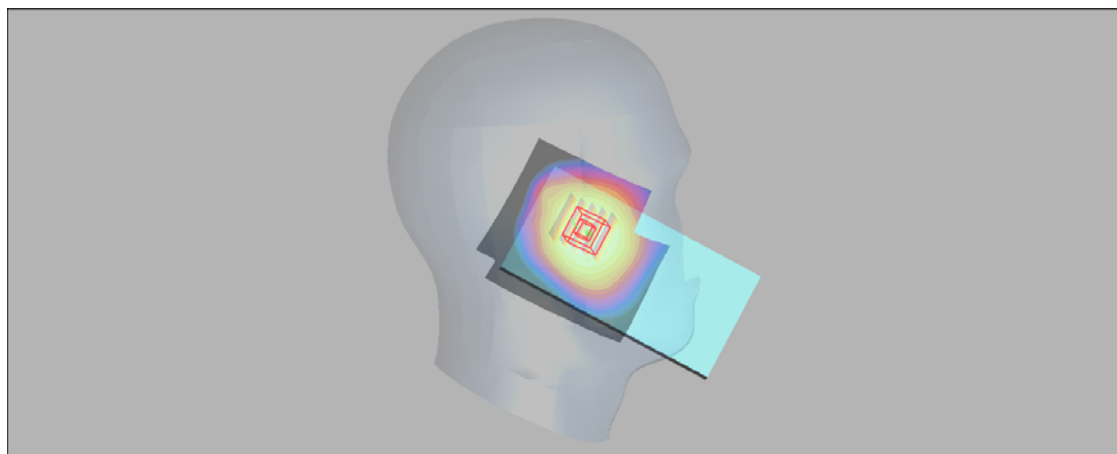
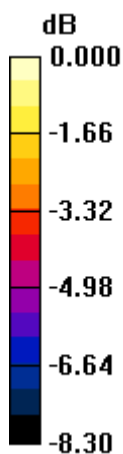

0 dB = 0.161mW/g

P09_LTE 7_QPSK20M_Left Cheek_21350_1RB_50 Offset

DUT: EUT

Communication System: LTE Band 7; Frequency: 2560 MHz; Duty Cycle: 1:1
 Medium: H2600 Medium parameters used: $f = 2560$ MHz; $\sigma = 2.01$ mho/m; $\epsilon_r = 37.8$; $\rho = 1000$ kg/m³

DASY4 Configuration:

- Probe: ES3DV3 - SN3090; ConvF(4.48, 4.48, 4.48); Calibrated: 2019/4/12
- Sensor-Surface: 3mm (Mechanical Surface Detection)
- Electronics: DAE4 Sn662; Calibrated: 2019/4/11
- Phantom: SAM 1; Type: QD 000 P40 CB; Serial: TP/1378
- ; Postprocessing SW: SEMCAD, V1.8 Build 186

Test/Area Scan (71x81x1): Measurement grid: dx=12mm, dy=12mm
 Maximum value of SAR (interpolated) = 0.296 mW/g

Test/Zoom Scan (5x5x7)/Cube 0: Measurement grid: dx=5mm, dy=5mm, dz=5mm
 Reference Value = 2.44 V/m; Power Drift = 0.04 dB
 Peak SAR (extrapolated) = 0.398 W/kg
SAR(1 g) = 0.226 mW/g; SAR(10 g) = 0.121 mW/g
 Maximum value of SAR (measured) = 0.281 mW/g

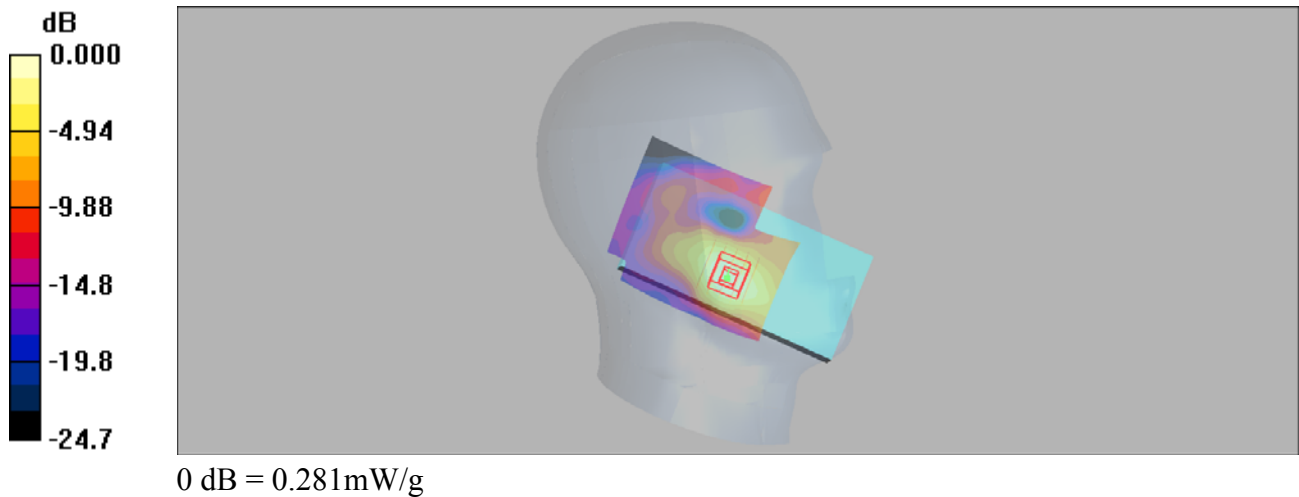

P10_LTE 12_QPSK10M_Left Cheek_23060_1 RB_24_Offset

DUT: EUT

Communication System: LTE Band 12; Frequency: 704 MHz; Duty Cycle: 1:1

Medium: H750 Medium parameters used: $f = 704 \text{ MHz}$; $\sigma = 0.846 \text{ mho/m}$; $\epsilon_r = 40.7$; $\rho = 1000 \text{ kg/m}^3$

DASY4 Configuration:

- Probe: ES3DV3 - SN3090; ConvF(6.22, 6.22, 6.22); Calibrated: 2019/4/12
- Sensor-Surface: 3mm (Mechanical Surface Detection)
- Electronics: DAE4 Sn662; Calibrated: 2019/4/11
- Phantom: SAM 1; Type: QD 000 P40 CB; Serial: TP/1378
- ; Postprocessing SW: SEMCAD, V1.8 Build 186

Test/Area Scan (71x81x1): Measurement grid: $dx=15\text{mm}$, $dy=15\text{mm}$

Maximum value of SAR (interpolated) = 0.238 mW/g

Test/Zoom Scan (5x5x7)/Cube 0: Measurement grid: $dx=8\text{mm}$, $dy=8\text{mm}$, $dz=5\text{mm}$

Reference Value = 4.79 V/m; Power Drift = 0.04 dB

Peak SAR (extrapolated) = 0.254 W/kg

SAR(1 g) = 0.219 mW/g; SAR(10 g) = 0.176 mW/g

Maximum value of SAR (measured) = 0.236 mW/g

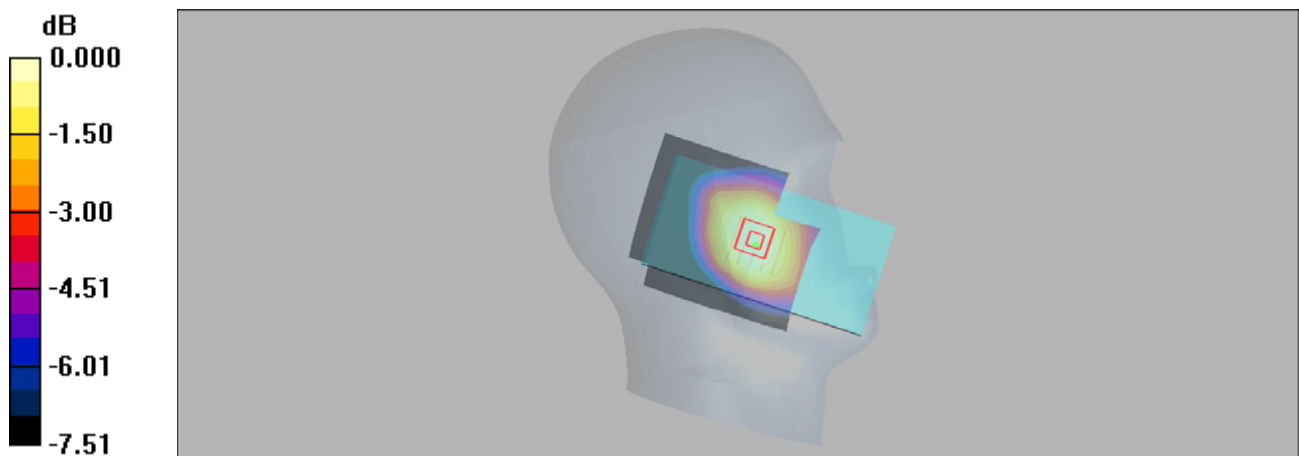

0 dB = 0.236mW/g

P11_802.11b_Right Cheek_6

DUT: EUT

Communication System: Wlan 802.11b; Frequency: 2437 MHz; Duty Cycle: 1:1
Medium: H2450 Medium parameters used: $f = 2437$ MHz; $\sigma = 1.76$ mho/m; $\epsilon_r = 40.2$; $\rho = 1000$ kg/m³

DASY4 Configuration:

- Probe: ES3DV3 - SN3090; ConvF(4.57, 4.57, 4.57); Calibrated: 2019/4/12
- Sensor-Surface: 3mm (Mechanical Surface Detection)
- Electronics: DAE4 Sn662; Calibrated: 2019/4/11
- Phantom: SAM 1; Type: QD 000 P40 CB; Serial: TP/1378
- ; Postprocessing SW: SEMCAD, V1.8 Build 186

Test/Area Scan (71x81x1): Measurement grid: dx=15mm, dy=15mm
Maximum value of SAR (interpolated) = 0.649 mW/g

Test/Zoom Scan (5x5x7)/Cube 0: Measurement grid: dx=8mm, dy=8mm, dz=5mm
Reference Value = 14.4 V/m; Power Drift = 0.039 dB
Peak SAR (extrapolated) = 0.843 W/kg
SAR(1 g) = 0.678 mW/g; SAR(10 g) = 0.253 mW/g
Maximum value of SAR (measured) = 0.586 mW/g

dB
■ 0.000

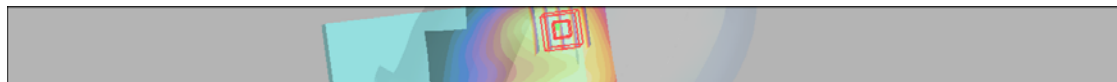

0 dB = 0.586mW/g

P12_GSM 850_GPRS10_Rear Face_10mm_128

DUT: EUT

Communication System: GPRS 850-2solt; Frequency: 824.2 MHz;Duty Cycle: 1:4
Medium: H850 Medium parameters used (interpolated): $f = 824.2$ MHz; $\sigma = 0.915$ mho/m; $\epsilon_r = 43$; $\rho = 1000$ kg/m³

DASY4 Configuration:

- Probe: ES3DV3 - SN3090; ConvF(6.12, 6.12, 6.12); Calibrated: 2019/4/12
- Sensor-Surface: 3mm (Mechanical Surface Detection)
- Electronics: DAE4 Sn662; Calibrated: 2019/4/11
- Phantom: SAM 1; Type: QD 000 P40 CB; Serial: TP/1378
- ; Postprocessing SW: SEMCAD, V1.8 Build 186

Test/Area Scan (71x81x1): Measurement grid: dx=15mm, dy=15mm
Maximum value of SAR (interpolated) = 0.753 mW/g

Test/Zoom Scan (5x5x7)/Cube 0: Measurement grid: dx=8mm, dy=8mm, dz=5mm
Reference Value = 24.6 V/m; Power Drift = -0.01 dB
Peak SAR (extrapolated) = 0.841 W/kg
SAR(1 g) = 0.673 mW/g; SAR(10 g) = 0.509 mW/g
Maximum value of SAR (measured) = 0.740 mW/g

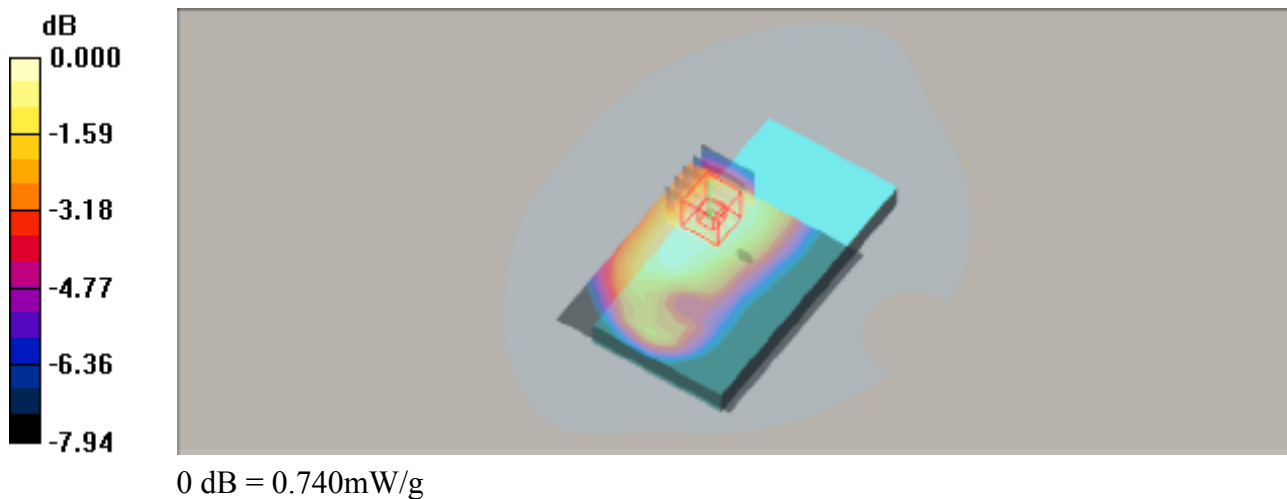

P13_GSM1900_GPRS12_Rear Face_10mm_810

DUT: EUT

Communication System: GPRS1900-4slots; Frequency: 1909.8 MHz; Duty Cycle: 1:2
Medium: H1900 Medium parameters used: $f = 1910$ MHz; $\sigma = 1.45$ mho/m; $\epsilon_r = 40.6$; $\rho = 1000$ kg/m³

DASY4 Configuration:

- Probe: ES3DV3 - SN3090; ConvF(5.06, 5.06, 5.06); Calibrated: 2019/4/12
- Sensor-Surface: 3mm (Mechanical Surface Detection)
- Electronics: DAE4 Sn662; Calibrated: 2019/4/11
- Phantom: SAM 2; Type: QD 000 P40 CB; Serial: TP-1376
- ; Postprocessing SW: SEMCAD, V1.8 Build 186

Test/Area Scan (71x81x1): Measurement grid: dx=15mm, dy=15mm
Maximum value of SAR (interpolated) = 0.972 mW/g

Test/Zoom Scan (5x5x7)/Cube 0: Measurement grid: dx=8mm, dy=8mm, dz=5mm
Reference Value = 19.5 V/m; Power Drift = -0.03 dB
Peak SAR (extrapolated) = 1.27 W/kg
SAR(1 g) = 0.738 mW/g; SAR(10 g) = 0.422 mW/g
Maximum value of SAR (measured) = 0.905 mW/g

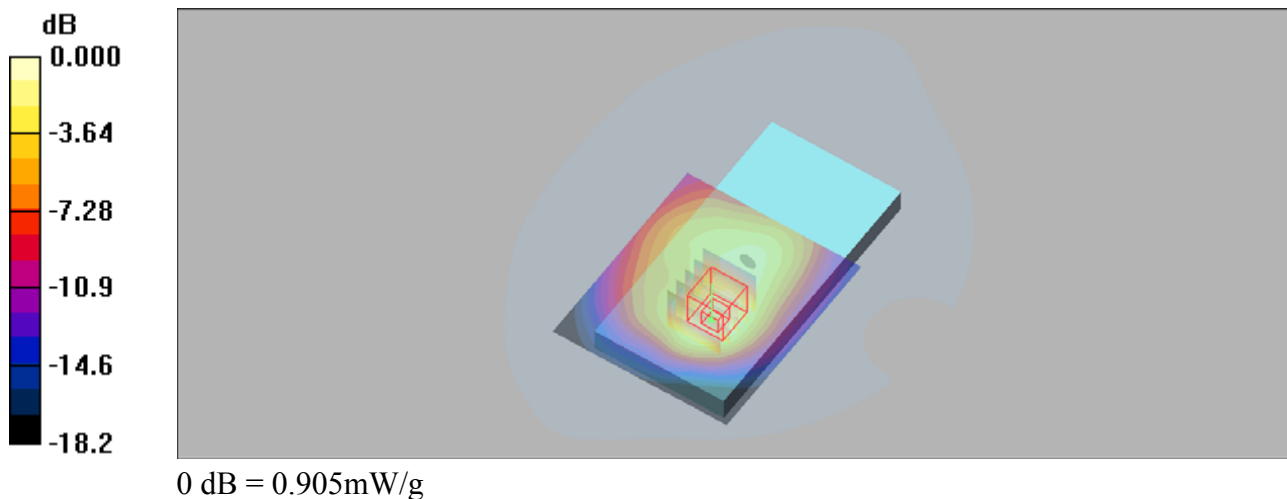

P14_WCDMA II_RMC12.2K_Rear Face_10mm_9538

DUT: EUT

Communication System: WCDMA Band II; Frequency: 1907.6 MHz; Duty Cycle: 1:1
Medium: H1900 Medium parameters used: $f = 1908$ MHz; $\sigma = 1.45$ mho/m; $\epsilon_r = 40.6$; $\rho = 1000$ kg/m³

DASY4 Configuration:

- Probe: ES3DV3 - SN3090; ConvF(5.06, 5.06, 5.06); Calibrated: 2019/4/12
- Sensor-Surface: 3mm (Mechanical Surface Detection)
- Electronics: DAE4 Sn662; Calibrated: 2019/4/11
- Phantom: SAM 2; Type: QD 000 P40 CB; Serial: TP-1376
- ; Postprocessing SW: SEMCAD, V1.8 Build 186

Test/Area Scan (71x81x1): Measurement grid: dx=15mm, dy=15mm
Maximum value of SAR (interpolated) = 0.871 mW/g

Test/Zoom Scan (5x5x7)/Cube 0: Measurement grid: dx=8mm, dy=8mm, dz=5mm
Reference Value = 19.2 V/m; Power Drift = -0.02 dB
Peak SAR (extrapolated) = 1.21 W/kg
SAR(1 g) = 0.694 mW/g; SAR(10 g) = 0.390 mW/g
Maximum value of SAR (measured) = 0.835 mW/g

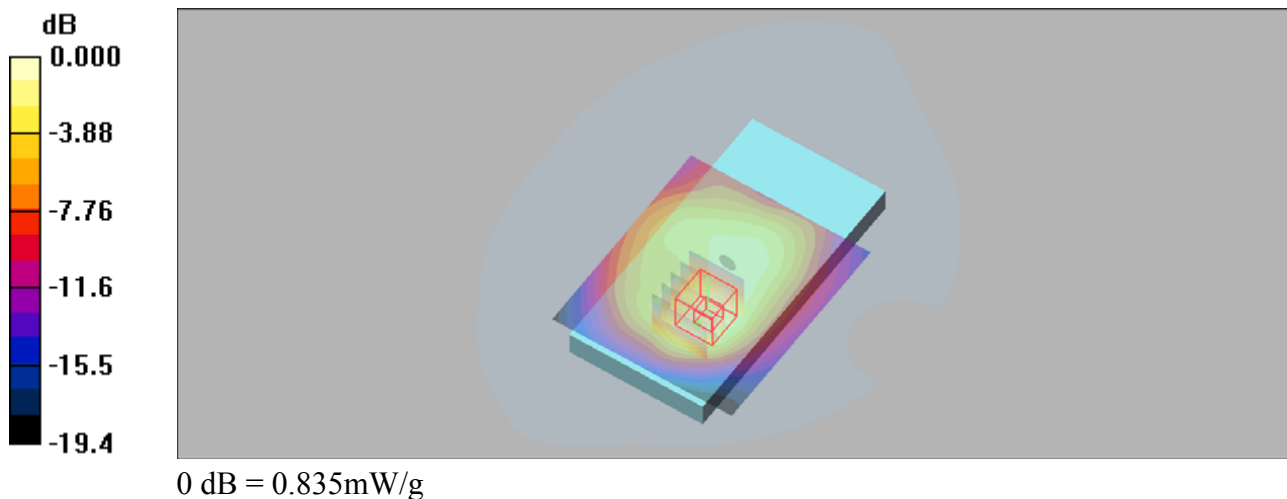

P15_WCDMA IV_RMC12.2K_Front Face_10mm_1513

DUT: EUT

Communication System: WCDMA Band IV; Frequency: 1752.6 MHz; Duty Cycle: 1:1
 Medium: H1750 Medium parameters used: $f = 1753$ MHz; $\sigma = 1.37$ mho/m; $\epsilon_r = 40.3$; $\rho = 1000$ kg/m³

DASY4 Configuration:

- Probe: ES3DV3 - SN3090; ConvF(5.36, 5.36, 5.36); Calibrated: 2019/4/12
- Sensor-Surface: 3mm (Mechanical Surface Detection)
- Electronics: DAE4 Sn662; Calibrated: 2019/4/11
- Phantom: SAM 2; Type: QD 000 P40 CB; Serial: TP-1376
- ; Postprocessing SW: SEMCAD, V1.8 Build 186

Test/Area Scan (71x81x1): Measurement grid: dx=15mm, dy=15mm
 Maximum value of SAR (interpolated) = 0.730 mW/g

Test/Zoom Scan (5x5x7)/Cube 0: Measurement grid: dx=8mm, dy=8mm, dz=5mm
 Reference Value = 12.1 V/m; Power Drift = -0.048 dB
 Peak SAR (extrapolated) = 0.912 W/kg
SAR(1 g) = 0.575 mW/g; SAR(10 g) = 0.351 mW/g
 Maximum value of SAR (measured) = 0.674 mW/g

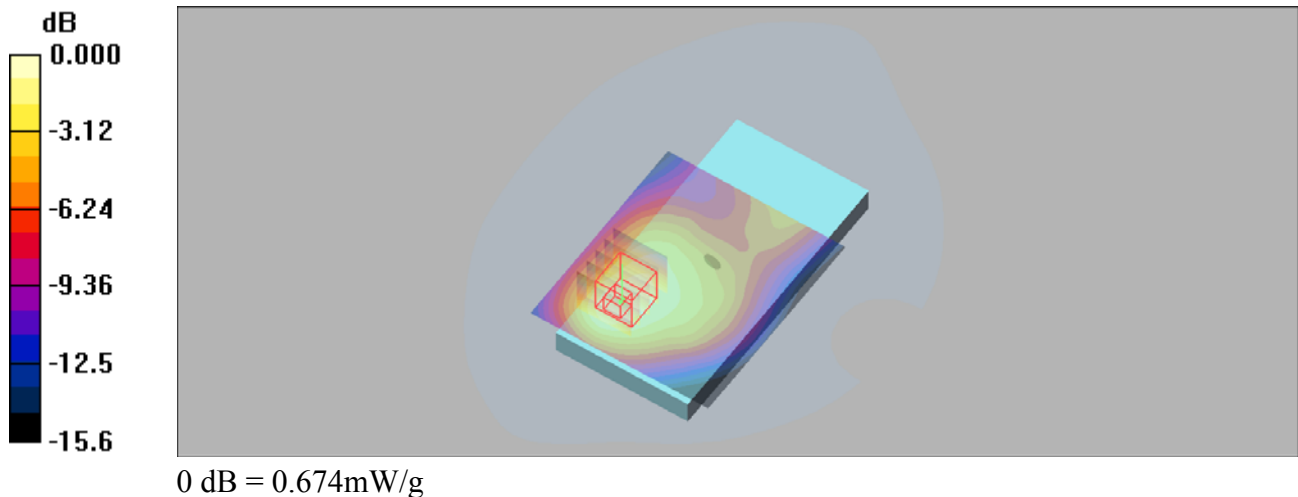

P16_WCDMA V_RMC12.2K_Rear Face_10mm_4132

DUT: EUT

Communication System: WCDMA Band V; Frequency: 826.4 MHz; Duty Cycle: 1:1

Medium: H850 Medium parameters used (interpolated): $f = 826.4$ MHz; $\sigma = 0.917$ mho/m; $\epsilon_r = 43$; $\rho = 1000$ kg/m³

DASY4 Configuration:

- Probe: ES3DV3 - SN3090; ConvF(6.12, 6.12, 6.12); Calibrated: 2019/4/12
- Sensor-Surface: 3mm (Mechanical Surface Detection)
- Electronics: DAE4 Sn662; Calibrated: 2019/4/11
- Phantom: SAM 1; Type: QD 000 P40 CB; Serial: TP/1378
- ; Postprocessing SW: SEMCAD, V1.8 Build 186

Test/Area Scan (71x81x1): Measurement grid: dx=15mm, dy=15mm
 Maximum value of SAR (interpolated) = 0.211 mW/g

Test/Zoom Scan (5x5x7)/Cube 0: Measurement grid: dx=8mm, dy=8mm, dz=5mm
 Reference Value = 13.3 V/m; Power Drift = 0.096 dB
 Peak SAR (extrapolated) = 0.243 W/kg
SAR(1 g) = 0.193 mW/g; SAR(10 g) = 0.146 mW/g
 Maximum value of SAR (measured) = 0.214 mW/g

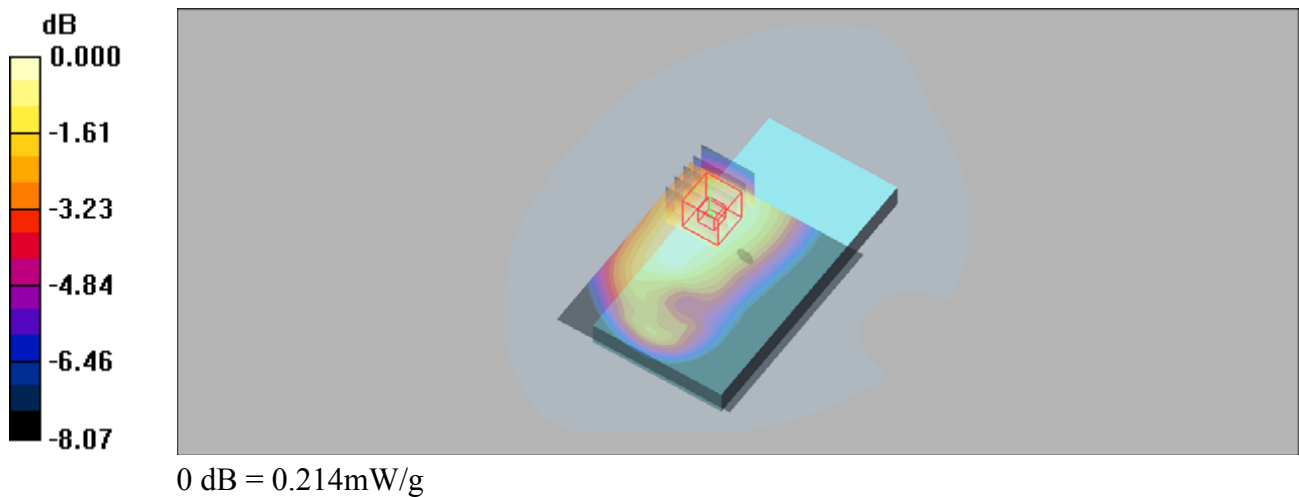

P17_LTE 2_QPSK20M_Rear Face_10mm_18700_1 RB_0_Offset

DUT: EUT

Communication System: LTE Band 2; Frequency: 1860 MHz; Duty Cycle: 1:1
 Medium: H1800 Medium parameters used: $f = 1800$ MHz; $\sigma = 1.44$ mho/m; $\epsilon_r = 40.3$; $\rho = 1000$ kg/m³

DASY4 Configuration:

- Probe: ES3DV3 - SN3090; ConvF(5.06, 5.06, 5.06); Calibrated: 2019/4/12
- Sensor-Surface: 3mm (Mechanical Surface Detection)
- Electronics: DAE4 Sn662; Calibrated: 2019/4/11
- Phantom: SAM 2; Type: QD 000 P40 CB; Serial: TP-1376
- ; Postprocessing SW: SEMCAD, V1.8 Build 186

Test/Area Scan (71x81x1): Measurement grid: dx=15mm, dy=15mm
 Maximum value of SAR (interpolated) = 0.935 mW/g

Test/Zoom Scan (5x5x7)/Cube 0: Measurement grid: dx=8mm, dy=8mm, dz=5mm
 Reference Value = 17.0 V/m; Power Drift = -0.074 dB
 Peak SAR (extrapolated) = 1.21 W/kg
SAR(1 g) = 0.680 mW/g; SAR(10 g) = 0.390 mW/g
 Maximum value of SAR (measured) = 0.831 mW/g

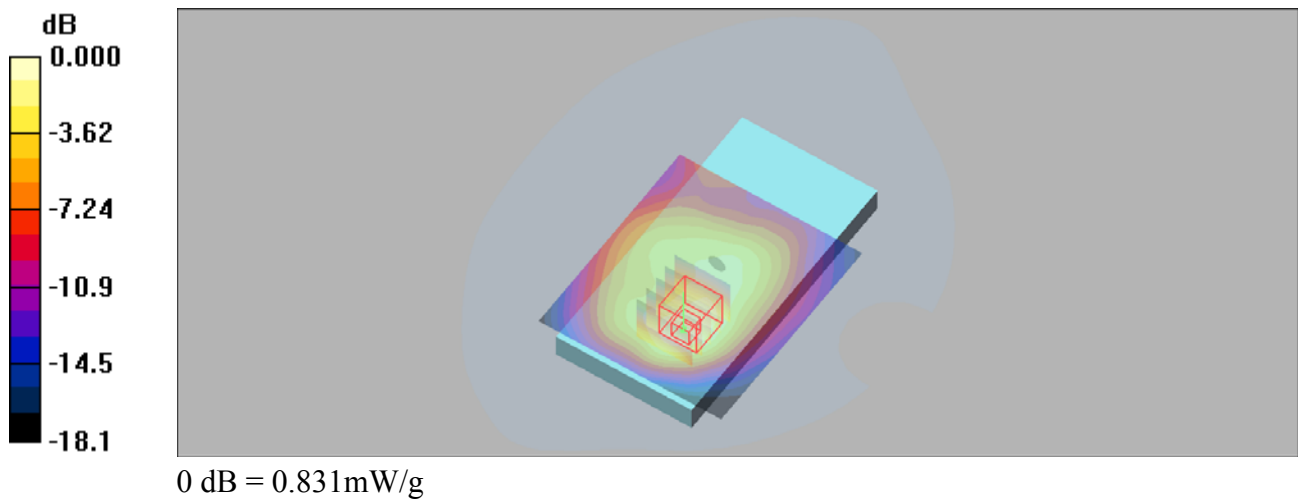

P18_LTE 4_QPSK20M_Front Face_10mm_20050_1 RB_50_Offset

DUT: EUT

Communication System: LTE Band 4&20M; Frequency: 1720 MHz;Duty Cycle: 1:1
Medium: H1800 Medium parameters used: $f = 1720$ MHz; $\sigma = 1.34$ mho/m; $\epsilon_r = 40.5$; $\rho = 1000$ kg/m³

DASY4 Configuration:

- Probe: ES3DV3 - SN3090; ConvF(5.36, 5.36, 5.36); Calibrated: 2019/4/12
- Sensor-Surface: 3mm (Mechanical Surface Detection)
- Electronics: DAE4 Sn662; Calibrated: 2019/4/11
- Phantom: SAM 2; Type: QD 000 P40 CB; Serial: TP-1376
- ; Postprocessing SW: SEMCAD, V1.8 Build 186

Test/Area Scan (71x81x1): Measurement grid: dx=15mm, dy=15mm
Maximum value of SAR (interpolated) = 0.633 mW/g

Test/Zoom Scan (5x5x7)/Cube 0: Measurement grid: dx=8mm, dy=8mm, dz=5mm
Reference Value = 11.9 V/m; Power Drift = -0.098 dB
Peak SAR (extrapolated) = 0.766 W/kg
SAR(1 g) = 0.507 mW/g; SAR(10 g) = 0.316 mW/g
Maximum value of SAR (measured) = 0.597 mW/g

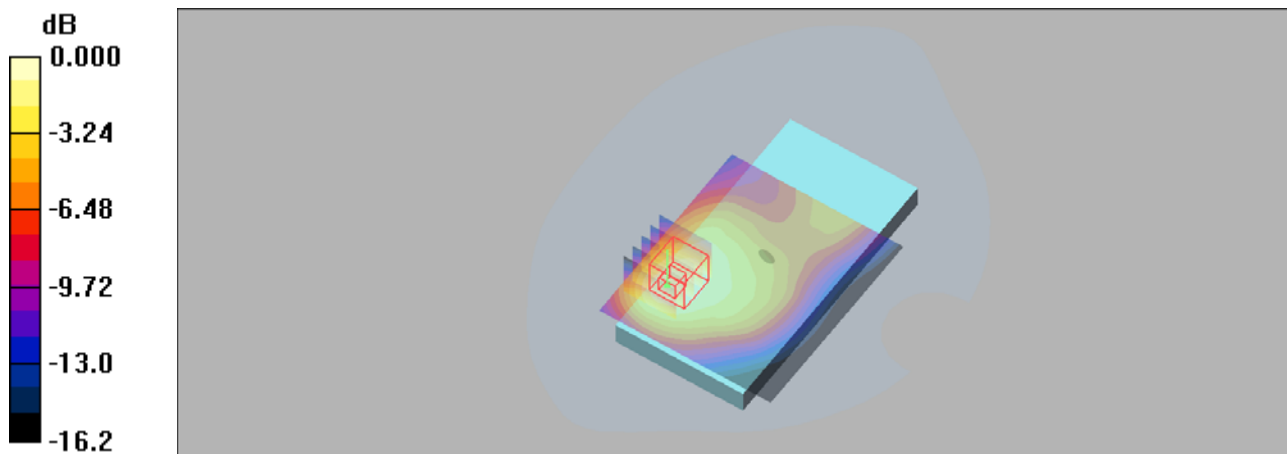

0 dB = 0.597mW/g

P19_LTE 5_QPSK10M_Rear Face_10mm_20525_1 RB_24 Offset

DUT: EUT

Communication System: LTE Band5; Frequency: 836.5 MHz;Duty Cycle: 1:1

Medium: H850 Medium parameters used (interpolated): $f = 836.5$ MHz; $\sigma = 0.927$ mho/m; $\epsilon_r = 42.8$;

$\rho = 1000$ kg/m³

DASY4 Configuration:

- Probe: ES3DV3 - SN3090; ConvF(6.12, 6.12, 6.12); Calibrated: 2019/4/12
- Sensor-Surface: 3mm (Mechanical Surface Detection)
- Electronics: DAE4 Sn662; Calibrated: 2019/4/11
- Phantom: SAM 1; Type: QD 000 P40 CB; Serial: TP/1378
- ; Postprocessing SW: SEMCAD, V1.8 Build 186

Test/Area Scan (71x81x1): Measurement grid: dx=15mm, dy=15mm

Maximum value of SAR (interpolated) = 0.165 mW/g

Test/Zoom Scan (5x5x7)/Cube 0: Measurement grid: dx=8mm, dy=8mm, dz=5mm

Reference Value = 11.9 V/m; Power Drift = -0.021 dB

Peak SAR (extrapolated) = 0.185 W/kg

SAR(1 g) = 0.147 mW/g; SAR(10 g) = 0.111 mW/g

Maximum value of SAR (measured) = 0.162 mW/g

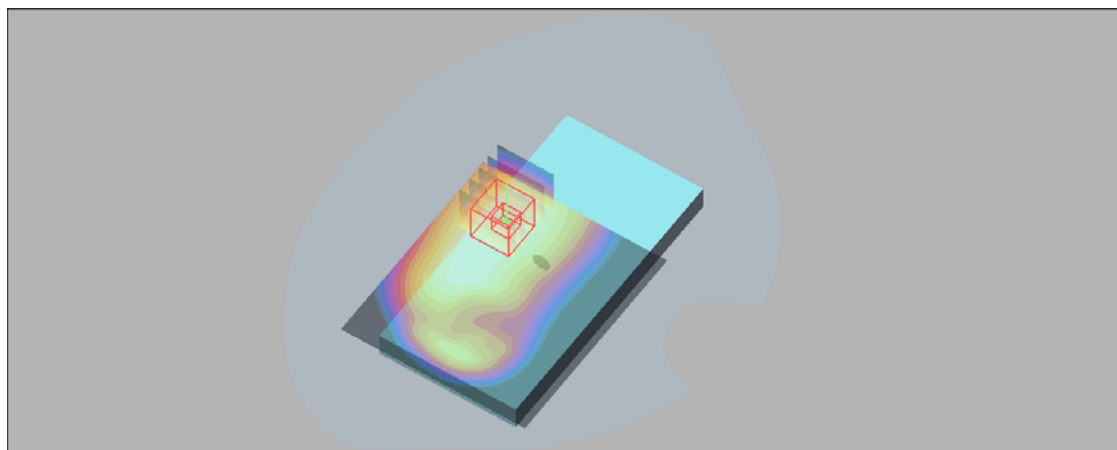
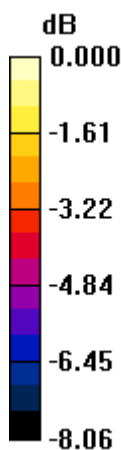

0 dB = 0.162mW/g

P20_LTE 7_QPSK20M_Rear Face_10mm_21350_1 RB_50_Offset

DUT: EUT

Communication System: LTE Band 7; Frequency: 2560 MHz; Duty Cycle: 1:1
 Medium: H2600 Medium parameters used: $f = 2560$ MHz; $\sigma = 2.01$ mho/m; $\epsilon_r = 37.8$; $\rho = 1000$ kg/m³

DASY4 Configuration:

- Probe: ES3DV3 - SN3090; ConvF(4.48, 4.48, 4.48); Calibrated: 2019/4/12
- Sensor-Surface: 3mm (Mechanical Surface Detection)
- Electronics: DAE4 Sn662; Calibrated: 2019/4/11
- Phantom: Triple Flat Phantom 5.1C; Type: QD 000 P51 CA; Serial: 1125
- ; Postprocessing SW: SEMCAD, V1.8 Build 186

Test/Area Scan (81x71x1): Measurement grid: dx=12mm, dy=12mm
 Maximum value of SAR (interpolated) = 1.36 mW/g

Test/Zoom Scan (5x5x7)/Cube 0: Measurement grid: dx=5mm, dy=5mm, dz=5mm
 Reference Value = 4.86 V/m; Power Drift = 0.02 dB
 Peak SAR (extrapolated) = 2.09 W/kg
SAR(1 g) = 1.05 mW/g; SAR(10 g) = 0.527 mW/g
 Maximum value of SAR (measured) = 1.35 mW/g

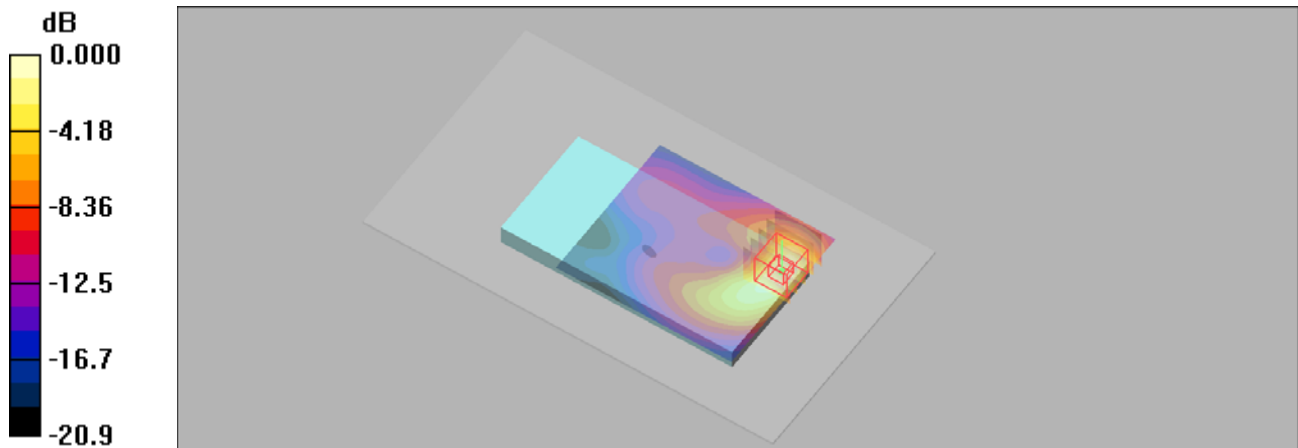

0 dB = 1.35mW/g

P21_LTE 12_QPSK10M_Rear Face_10mm_23060_1RB_24 Offset

DUT: EUT

Communication System: LTE Band 12; Frequency: 704 MHz; Duty Cycle: 1:1

Medium: H750 Medium parameters used: $f = 704$ MHz; $\sigma = 0.846$ mho/m; $\epsilon_r = 40.7$; $\rho = 1000$ kg/m³

DASY4 Configuration:

- Probe: ES3DV3 - SN3090; ConvF(6.22, 6.22, 6.22); Calibrated: 2019/4/12
- Sensor-Surface: 3mm (Mechanical Surface Detection)
- Electronics: DAE4 Sn662; Calibrated: 2019/4/11
- Phantom: SAM 1; Type: QD 000 P40 CB; Serial: TP/1378
- ; Postprocessing SW: SEMCAD, V1.8 Build 186

Test/Area Scan (71x81x1): Measurement grid: dx=15mm, dy=15mm

Maximum value of SAR (interpolated) = 0.506 mW/g

Test/Zoom Scan (5x5x7)/Cube 0: Measurement grid: dx=8mm, dy=8mm, dz=5mm

Reference Value = 24.7 V/m; Power Drift = -0.069 dB

Peak SAR (extrapolated) = 0.568 W/kg

SAR(1 g) = 0.462 mW/g; SAR(10 g) = 0.359 mW/g

Maximum value of SAR (measured) = 0.503 mW/g

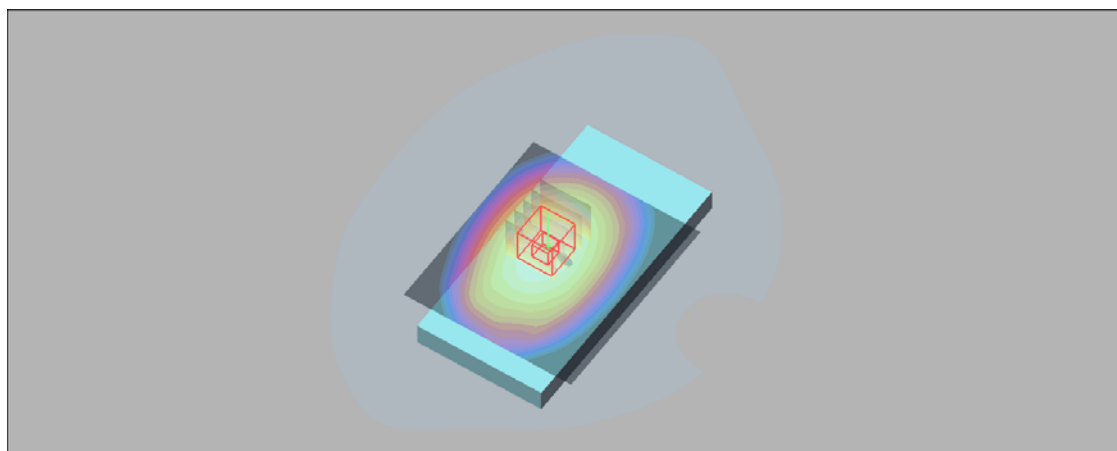
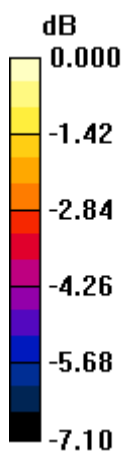

0 dB = 0.503mW/g

P22_802.11b_Front Face_10mm_6

DUT: EUT

Communication System: Wlan 802.11b; Frequency: 2437 MHz; Duty Cycle: 1:1

Medium: H2450 Medium parameters used: $f = 2437$ MHz; $\sigma = 1.76$ mho/m; $\epsilon_r = 40.2$; $\rho = 1000$ kg/m³

DASY4 Configuration:

- Probe: ES3DV3 - SN3090; ConvF(4.57, 4.57, 4.57); Calibrated: 2019/4/12
- Sensor-Surface: 3mm (Mechanical Surface Detection)
- Electronics: DAE4 Sn662; Calibrated: 2019/4/11
- Phantom: SAM 1; Type: QD 000 P40 CB; Serial: TP/1378
- ; Postprocessing SW: SEMCAD, V1.8 Build 186

Test/Area Scan (71x81x1): Measurement grid: dx=15mm, dy=15mm
 Maximum value of SAR (interpolated) = 0.225 mW/g

Test/Zoom Scan (5x5x7)/Cube 0: Measurement grid: dx=8mm, dy=8mm, dz=5mm
 Reference Value = 3.26 V/m; Power Drift = 0.03 dB
 Peak SAR (extrapolated) = 0.307 W/kg
SAR(1 g) = 0.177 mW/g; SAR(10 g) = 0.097 mW/g
 Maximum value of SAR (measured) = 0.217 mW/g

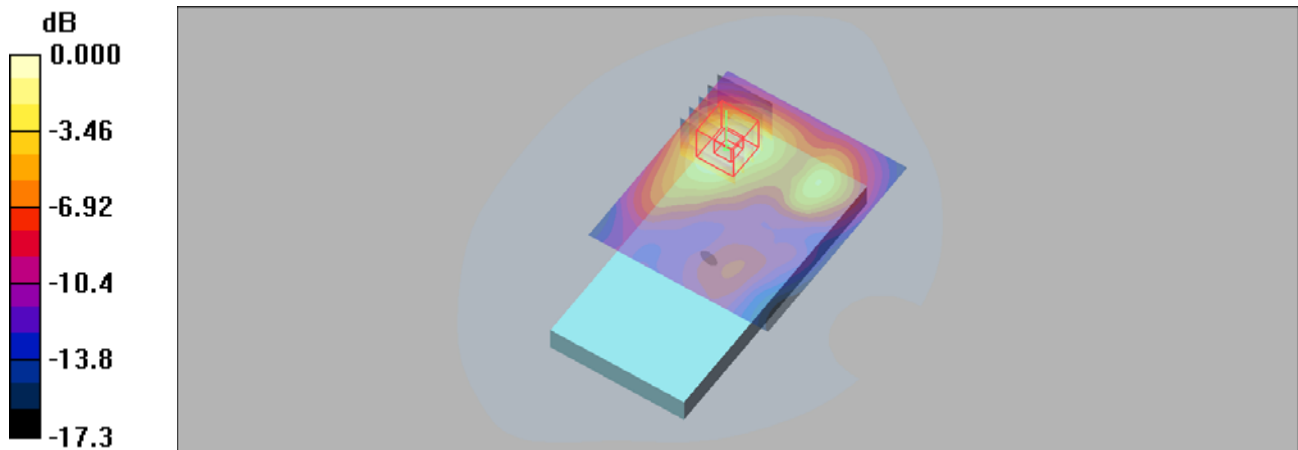

0 dB = 0.217mW/g